



US 20110036474A1

(19) **United States**
(12) **Patent Application Publication**
Phillips

(10) **Pub. No.: US 2011/0036474 A1**
(43) **Pub. Date: Feb. 17, 2011**

(54) **COVER FOR A BICYCLE**

(30) **Foreign Application Priority Data**

(76) Inventor: **Anthony Garth Phillips, Brisbane**
(AU)

May 6, 2008 (AU) 2008100410

Publication Classification

Correspondence Address:
SHOEMAKER AND MATTARE, LTD
10 POST OFFICE ROAD - SUITE 100
SILVER SPRING, MD 20910 (US)

(51) **Int. Cl.**
B65D 65/02 (2006.01)

(52) **U.S. Cl.** **150/167**

(21) Appl. No.: **12/989,177**

(57) **ABSTRACT**

(22) PCT Filed: **May 6, 2009**

The present invention relates to a cover for a bicycle or like vehicle being made of light weight material with one or more cover fasteners wherein the cover is enclosable entirely about the bicycle or like vehicle and the light weight material is foldable to be reduced in size when not in use for easy storage.

(86) PCT No.: **PCT/AU2009/000561**

§ 371 (c)(1),
(2), (4) Date: **Oct. 22, 2010**

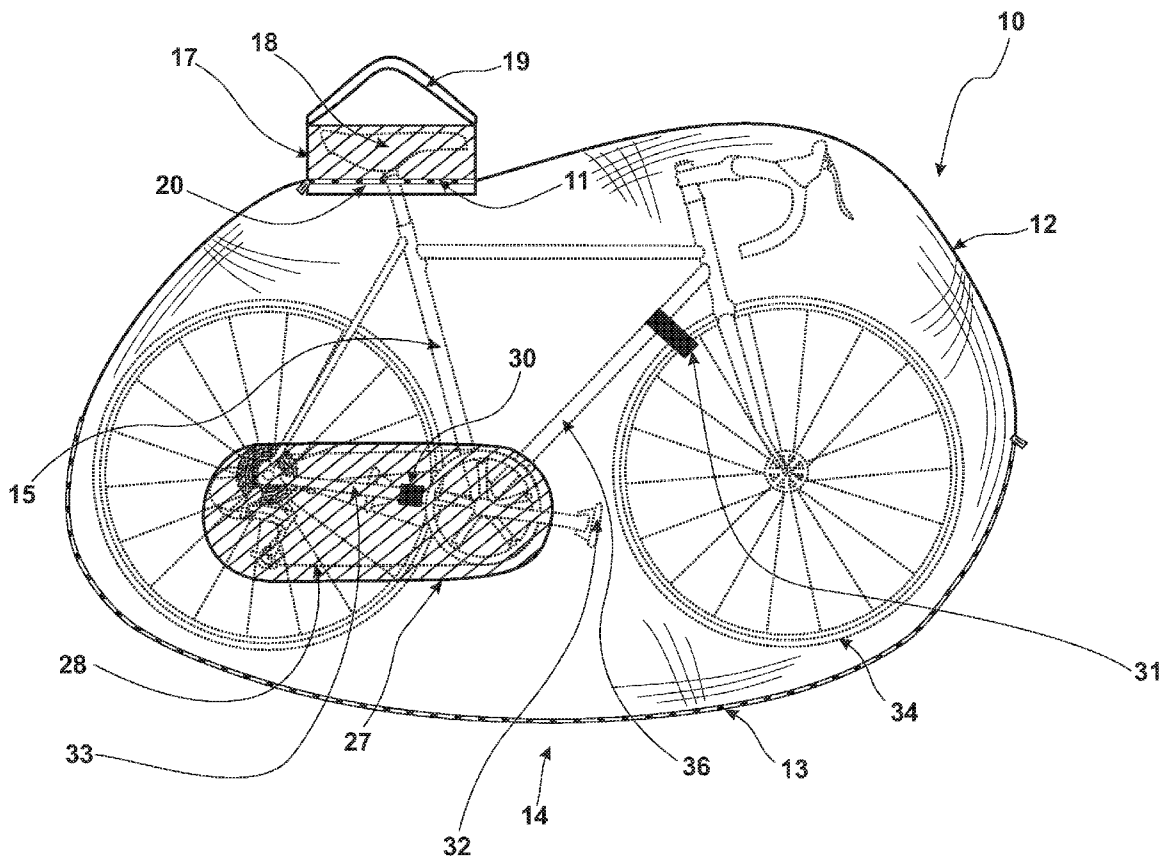

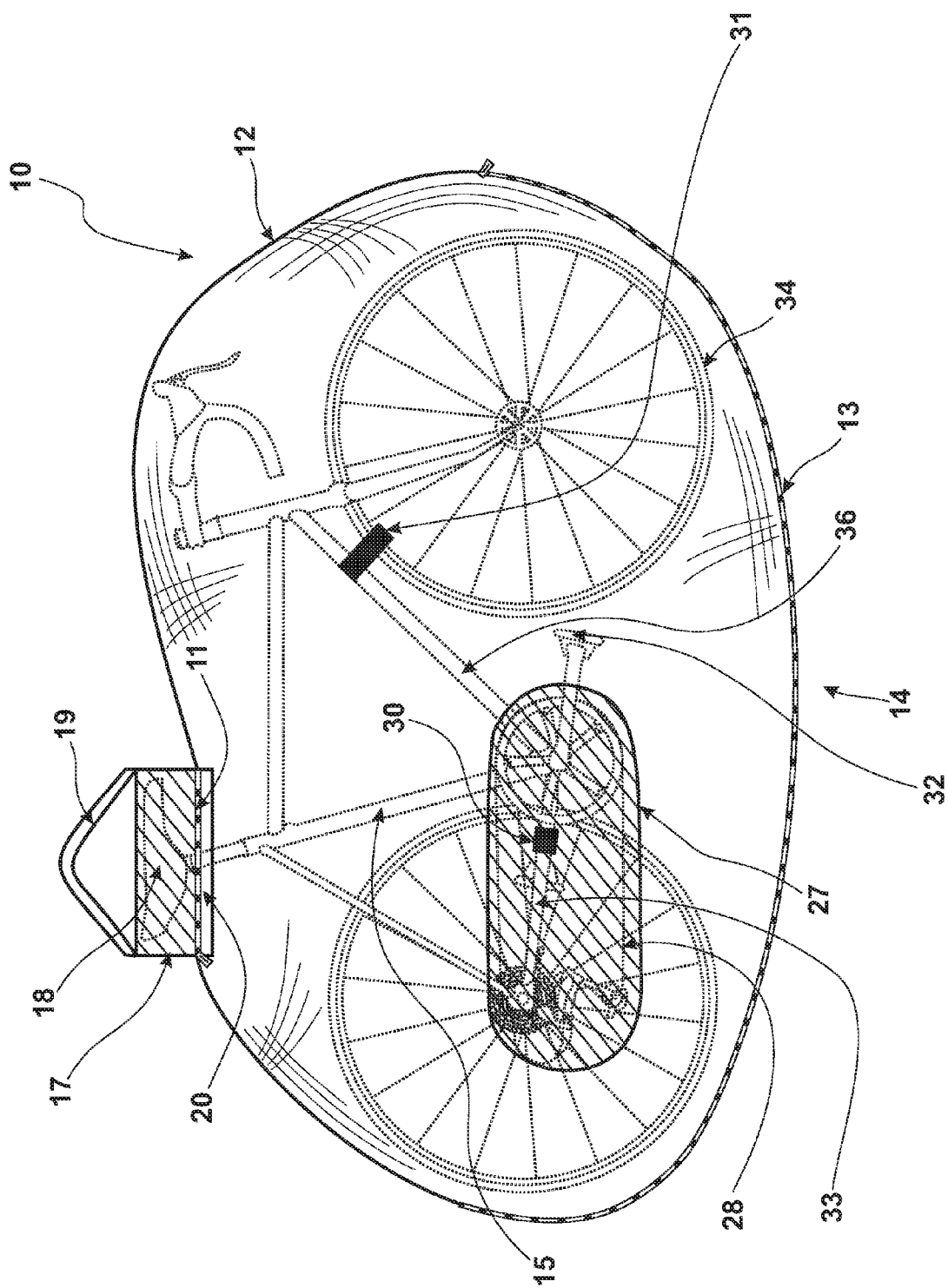

Fig. 1

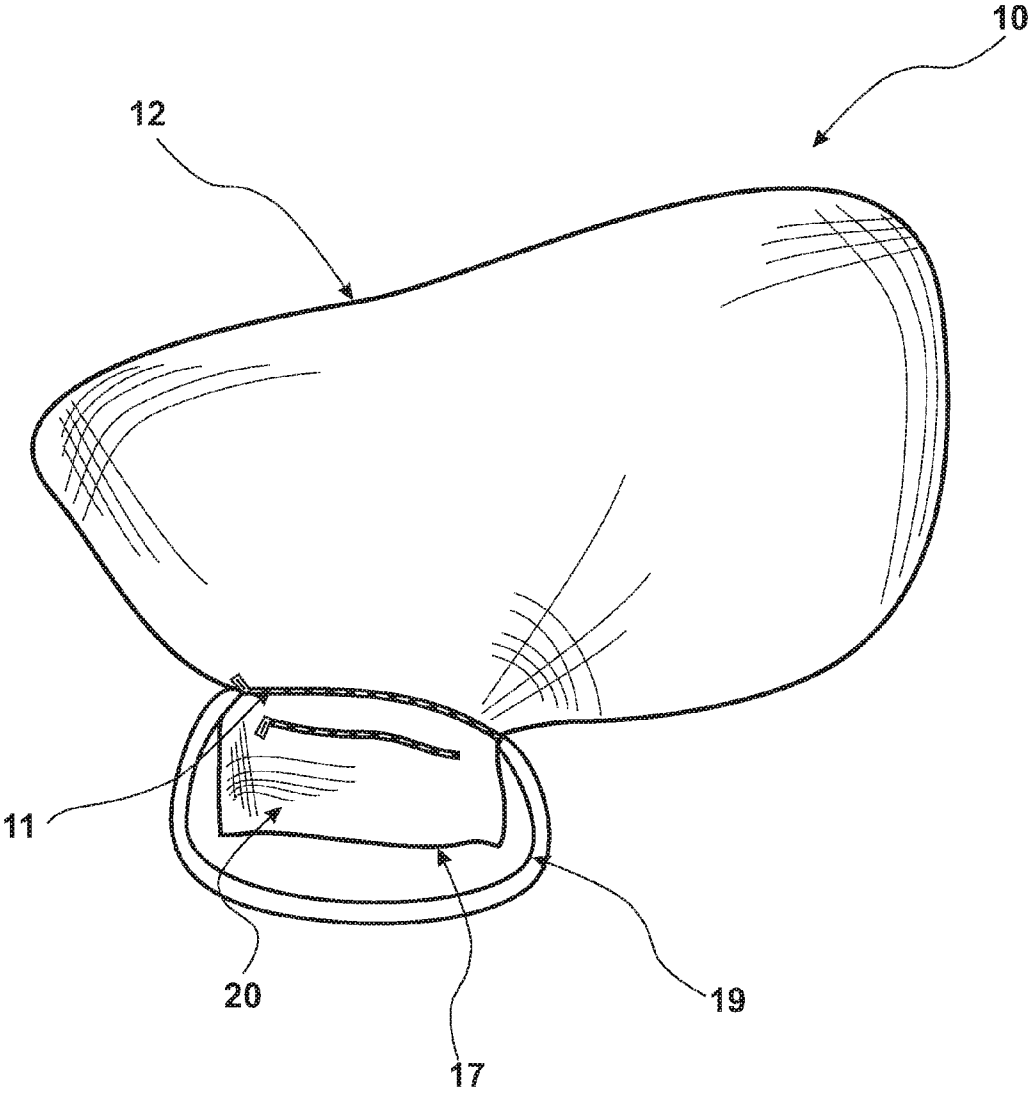

Fig. 2

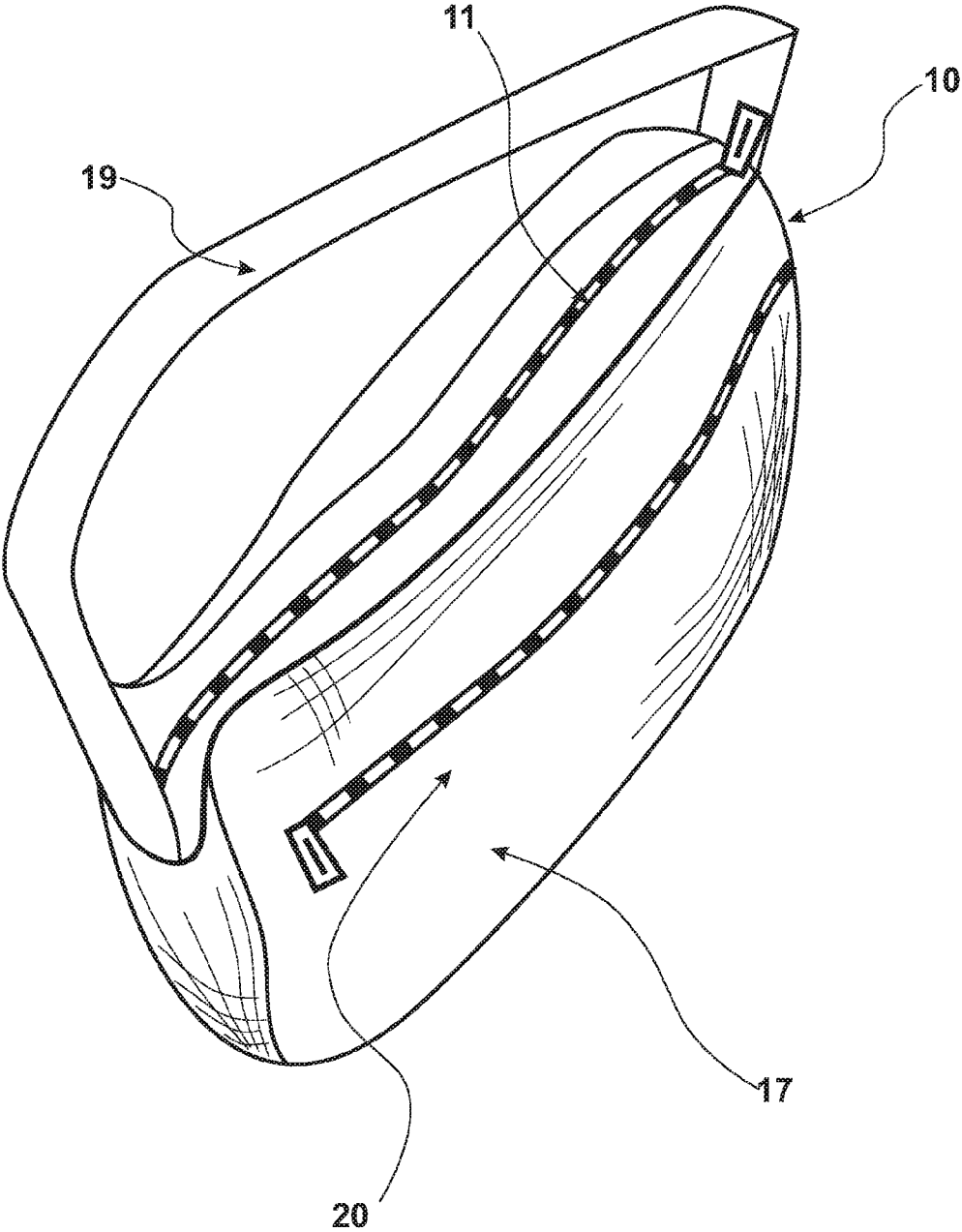

Fig. 3

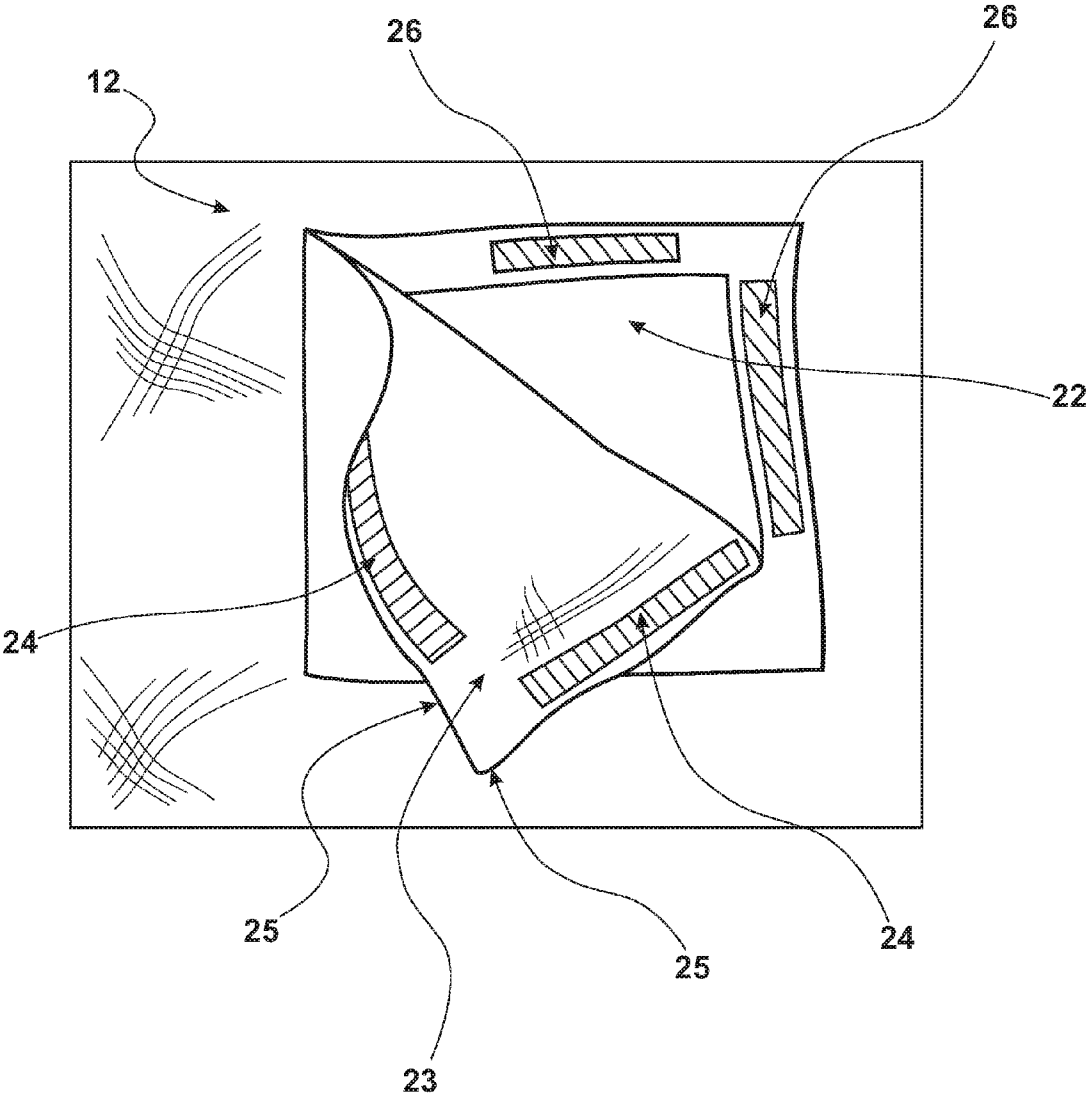

Fig. 4

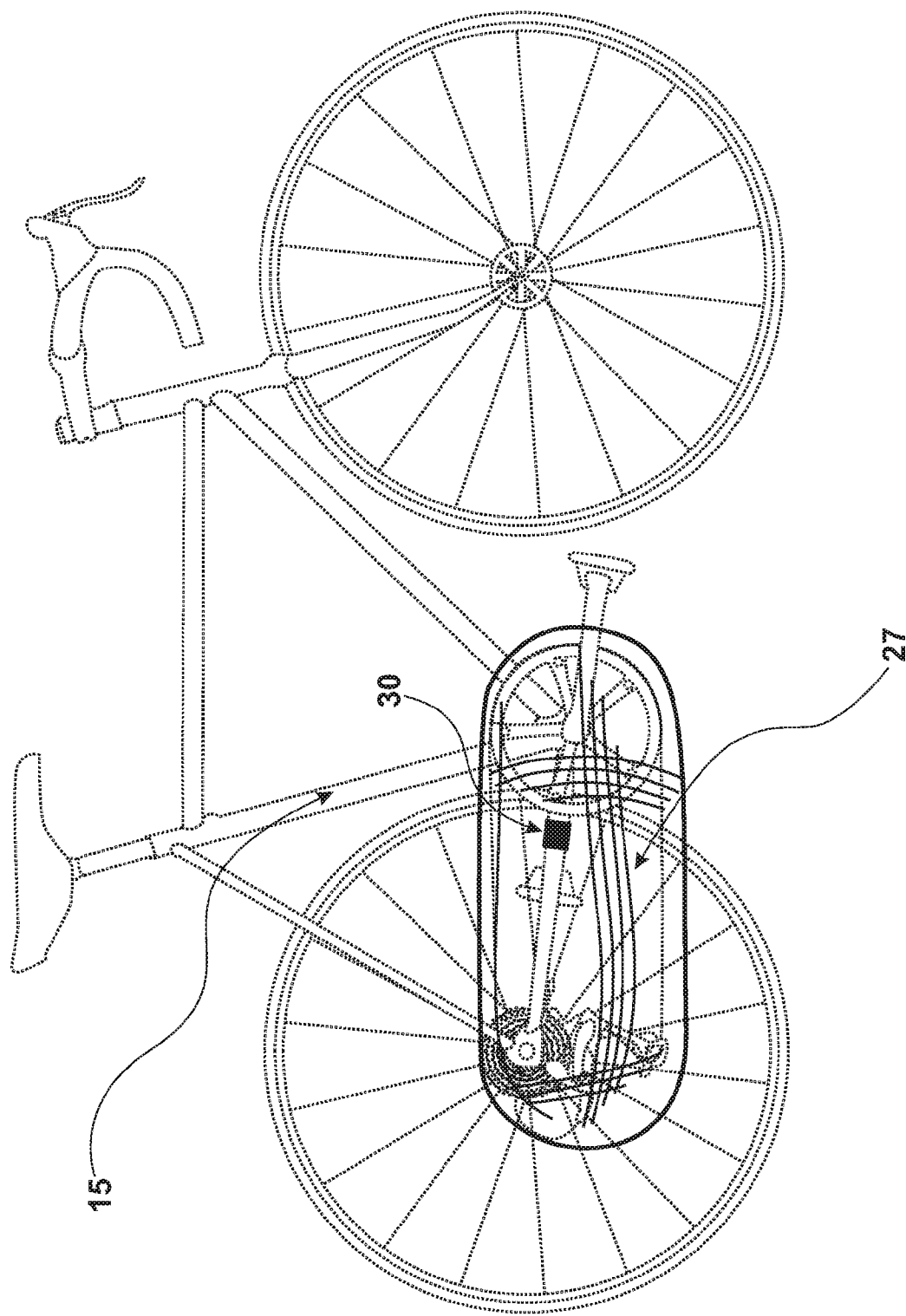

Fig. 5

COVER FOR A BICYCLE

FIELD OF INVENTION

[0001] The present invention relates to vehicle covers. The present invention has particular but not exclusive application for use with a bicycle.

BACKGROUND OF THE INVENTION

[0002] Covers for bicycles have been developed to protect them from the weather when stored or during transport to another location. Prolonged exposure to rain and sunlight will damage the bicycles. Dirt from the roads splashed onto the bicycles during transport causes them to become dirty and adversely affect the performance of the bicycle.

[0003] There are currently two types of bicycle covers that are used to protect bicycles. The first bicycle cover is a shaped plastic covering that can be positioned over the bicycle but does not fully enclose the bicycle. The cover is used when storing the bicycle. However the cover can easily be blown about or off exposing the bicycle to the weather elements. The second type of bicycle cover is a hard case cover where the bicycle is disassembled for storage or long-haulage purposes. The cover cannot be folded for compact storage.

[0004] None of these bicycle covers can be used to cover a bicycle mounted on a tow-bar rack or roof rack of a car and thus does not address the problem of accumulation of dirt and road grime during transport.

OBJECT OF THE INVENTION

[0005] It is an object of the present invention to provide an alternate bicycle cover which overcomes at least in part one or more of the above mentioned disadvantages.

SUMMARY OF THE INVENTION

[0006] In one aspect the present invention broadly resides in a cover for a bicycle or like vehicle being made of light weight material with one or more cover fasteners, the cover is shaped to surround the bicycle or like vehicle and the one or more cover fasteners close the bicycle or like vehicle wherein the cover is enclosable about the bicycle or like vehicle and the light weight material is foldable to be reduced in size when not in use for easy storage.

[0007] In another aspect the present invention broadly resides in a cover for a bicycle or like vehicle including

[0008] a cover portion being made of light weight material for surrounding the bicycle or like vehicle; and

[0009] one or more cover fasteners for closing the cover portion wherein the cover portion is enclosable with the one or more cover fasteners about the bicycle or like vehicle and the cover portion is foldable to be reduced in size when not in use for easy storage.

[0010] The light weight material is preferably made of thin layer of nylon sheeting.

[0011] The light weight material is preferably a waterproof material.

[0012] Preferably, the light weight material is a UV stabilized material.

[0013] Preferably the cover is shaped to closely and securely fit about the bicycle or like vehicle.

[0014] The cover portion is preferably shaped to entirely surround an assembled bicycle. The cover preferably entirely encloses an assembled bicycle.

[0015] The cover portion is preferably foldable to fit within a pouch.

[0016] The pouch is preferably part of the cover portion or alternately is a separate article.

[0017] The pouch is preferably sized to enable the pouch to be positioned over a seat of the bicycle or like vehicle.

[0018] Preferably, the pouch has an adjustable strap.

[0019] The pouch preferably has one or more pockets for storage.

[0020] The one or more cover fasteners preferably include one or more zips, Velcro strips, snap fit fasteners or any combination of fasteners.

[0021] The cover portion preferably has an aperture for allowing the bicycle tow-bar rack to pass through the cover and clamp to the bicycle frame.

[0022] The aperture is preferably closeable with a flap.

[0023] In one embodiment the flap has a side that is attached to the cover portion.

[0024] In another embodiment the flap is a separate piece of material that is attachable to the cover portion adjacent the periphery of the aperture.

[0025] The flap preferably has free edges that are attachable to the cover portion by one or more flap fasteners.

[0026] The flap is preferably made of the same light weight material as the cover portion.

[0027] The cover preferably further includes a cap to cover the chain of the bicycle.

[0028] The cap preferably has an elastic band around the periphery of the cap.

[0029] The cap is preferably made of the same light weight material as the cover portion.

[0030] The cover preferably further includes one or more securing strips to restrain movement of moving parts of the bicycle or like vehicle.

[0031] Preferably, the one or more securing strips include a first strip to secure pedals of the bicycle or like vehicle to a frame of the bicycle or like vehicle.

[0032] More preferably, the one or more securing strips also include a second strip to secure a wheel of the bicycle or like vehicle to the frame of the bicycle or like vehicle.

BRIEF DESCRIPTION OF THE DRAWINGS

[0033] In order that the present invention can be more readily understood reference will now be made to the accompanying drawings which illustrate a preferred embodiment of the invention and wherein:

[0034] FIG. 1 is a diagrammatic view of a bicycle cover according to one embodiment of the invention and shown when in use to enclose a bicycle;

[0035] FIG. 2 is a diagrammatic view of a bicycle cover of FIG. 1 showing the cover portion with an attached pouch;

[0036] FIG. 3 is a diagrammatic view of the bicycle cover of FIG. 2 folded and contained within the pouch;

[0037] FIG. 4 is a diagrammatic view of a section of the cover portion of the bicycle cover of FIG. 1 showing a closeable aperture that enables a bicycle rack to pass through the bicycle cover; and

[0038] FIG. 5 is a diagrammatic view of a cap of the bicycle cover of FIG. 1 shown covering the chain of the bicycle.

DETAILED DESCRIPTION OF THE PREFERRED EMBODIMENT

[0039] With reference to FIGS. 1 to 3 there is shown a bicycle cover 10 that has a cover portion 12 and a cover zip 13. The cover zip 13 is used to open and close the cover 10. The opening 14 enables the bicycle cover 10 to be placed about and surround a bicycle 15. The closing of the opening 14 closes the cover portion 12 to enclose the bicycle 15 within the bicycle cover 10.

[0040] The cover portion 12 is made of a light weight material such as a thin layer of nylon. The nylon is treated during the manufacturing process so that it is waterproof and is resistant to UV degradation. As the cover portion 12 is light weight and thin, the cover portion 12 can be easily folded to reduce its size when the cover 10 is not in use. The cover portion 12 is foldable on itself and can fit within a pouch 17. The pouch 17 can be opened and closed with a pouch zip 11.

[0041] In the preferred embodiment, the pouch 17 is part of the cover portion 12. The pouch 17 is made to a size that enables the pouch 17 to be positioned over the bicycle seat 18. The pouch 17 has an adjustable strap 19 that serves as a handle for carrying the pouch 17. There are pockets 20 on opposed sides of the pouch 17 and the pockets 20 can be used for storage purposes.

[0042] The cover portion 12 has an aperture 22 that enables a bicycle rack (not shown in the Figures) to pass through the aperture 22. The bicycle tow-bar rack is fixed to the rear of a car or four wheel drive. The aperture 22 allows access to the frame of the bicycle 15 so that the bicycle 15 can be mounted on the bicycle tow-bar rack. The aperture 22 can be closed off with a flap 23. The bicycle 15 can therefore be enclosed within the bicycle cover 10 while being transported from one destination to another destination. The bicycle 15 is therefore protected from being damaged by exposure to weather elements, dirt road grime and damage caused by loose stones thrown from the road. The flap 23 is a separate piece of thin layer nylon and is attachable to the cover portion 12 with flap Velcro strips 24. The flap Velcro strips 24 are positioned near the free edges 25 of the flap 23 and can attach to complementary Velcro strips 26 positioned near the periphery of the aperture 22.

[0043] The preferred embodiment the cover 10 includes a cap 27 that is used to cover the bicycle chain 28 of a bicycle 15. The cap 27 is made of thin layer nylon and has an elastic band around the periphery of the cap 27. The elastic band enables the cap 27 to be easily placed on and removed from the bicycle chain 28. The cap 27 can be stored in one of the pockets 20 of the pouch 17 when the cap 27 is not in use.

[0044] The preferred embodiment also includes several securing strips 30, 31 to restrain movement of the moving parts of the bicycle 15. For example, the cover 10 has a pedal securing strip 30 and a wheel securing strip 31. The pedal securing strip 30 is used to secure the pedals 32 to a lower frame support 33 of the bicycle 15 that is located between the back wheel and the pedals 32. The wheel securing strip 31 is used to secure the front wheel 34 of the bicycle 15 to an upper frame support 36 of the bicycle 15 that is located between the pedals 32 and the front wheel 34.

ADVANTAGES

[0045] An advantage of the preferred embodiment of the bicycle cover includes being able to totally enclose a bicycle

and protect it from the weather. Another advantage of the preferred embodiment of the bicycle cover is that it is light weight and can be easily folded and reduced in size for storage purposes.

[0046] A further advantage of the preferred embodiment of the bicycle cover is the provision of an aperture to enable a bicycle rack to pass through the cover. This enables bicycle to be covered by the bicycle cover while being transported on a bicycle rack mounted to a car.

VARIATIONS

[0047] It will of course be realised that while the foregoing has been given by way of illustrative example of this invention, all such and other modifications and variations thereto as would be apparent to persons skilled in the art are deemed to fall within the broad scope and ambit of this invention as is herein set forth.

[0048] Throughout the description and claims this specification the word “comprise” and variations of that word such as “comprises” and “comprising”, are not intended to exclude other additives, components, integers or steps.

1-8. (canceled)

9. A cover for a bicycle or like vehicle including

a cover portion being made of light weight material for surrounding the bicycle or like vehicle; and

one or more cover fasteners for closing the cover portion wherein the cover portion is enclosable with the one or more cover fasteners about the bicycle or like vehicle and the cover portion is foldable to be reduced in size when not in use for easy storage.

10. A cover as claimed in claim 9 wherein the light weight material is made of a thin layer of nylon sheeting and entirely encloses an assembled bicycle, the cover portion is foldable to fit within a pouch.

11. A cover as claimed in claim 9 wherein the light weight material is substantially waterproof and is UV stabilized.

12. A cover as claimed in claim 9, wherein the cover is shaped to closely and securely fit about the bicycle or like vehicle.

13. A cover as claimed in claim 9, wherein the cover has a zip opening.

14. A cover as claimed in claim 9, wherein when the bicycle or like vehicle is a bicycle, and the cover portion has an aperture for allowing a bicycle tow-bar rack to pass through the cover and clamp to the bicycle frame.

15. A cover as claimed in claim 14, wherein the aperture is closeable with a flap.

16. A cover as claimed in claim 9, wherein when the bicycle or like vehicle is a bicycle, the cover includes a cap to cover the chain of the bicycle and one or more securing strips to restrain movement of the moving parts of the bicycle.

17. A cover as claimed in claim 16, wherein the cap is made of thin layer nylon and has an elastic band around the periphery of the cap.

18. A cover as claimed in claim 16, comprising a pedal securing strip and a wheel securing strip.

19. A cover as claimed in claim 9, wherein the cover includes a pouch for storing the folded cover when not in use

20. A cover as claimed in claim 19, wherein the pouch is part of the cover portion and is sized to enable the pouch to be positioned over a seat of the bicycle or like vehicle.

21. A cover as claimed in claim 19, wherein the pouch has one or more pockets for storage.

22. A cover as claimed in claim 9, wherein when the bicycle or like vehicle is a bicycle, the cover has a zip opening to locate and secure the cover about the bicycle, the cover includes a cap to cover the chain of the bicycle and or one or more securing strips to restrain movement of the moving parts of the bicycle, the cover portion has an aperture for allowing a bicycle tow-bar rack to pass through the cover and clamp to the bicycle frame, said aperture is sealable with a flap, the cover includes a pouch for storing the folded cover when not in use and is positionable over the bicycle seat when the cover is secured about the bicycle.

23. A cover as claimed in claim 9 wherein the vehicle is a bicycle; the cover includes a zip opening; said cover entirely encloses an assembled bicycle and is shaped to closely and securely fit about the said assembled bicycle; the cover por-

tion is made of a thin layer of substantially waterproof and UV stabilized nylon sheeting, and is foldable to fit within an integral pouch for storing the cover when not in use; said pouch has an adjustable strap that serves as a carrying handle, side pockets for storage purposes, and is positionable over the bicycle seat when the cover is secured about the bicycle; the cover portion has an aperture for allowing a bicycle tow-bar rack to pass through the cover and clamp to the bicycle frame, said aperture is sealable with a flap attachable to the cover portion with Velcro strips; the cover includes a cap made of thin layer nylon and having an elastic band around its periphery to cover the chain of the bicycle, and a pedal securing strip and wheel securing strip to restrain movement.

* * * * *