

(19) World Intellectual Property Organization  
International Bureau



(43) International Publication Date  
19 September 2002 (19.09.2002)

PCT

(10) International Publication Number  
**WO 02/073587 A1**

(51) International Patent Classification<sup>7</sup>: **G09G 5/00**

(21) International Application Number: PCT/US02/07102

(22) International Filing Date: 8 March 2002 (08.03.2002)

(25) Filing Language: English

(26) Publication Language: English

(30) Priority Data:  
60/274,444 9 March 2001 (09.03.2001) US  
09/917,263 26 July 2001 (26.07.2001) US

(71) Applicant: **IMMERSION CORPORATION** [US/US];  
801 Fox Lane, San Jose, CA 95131 (US).

(72) Inventors: **SHAHOIAN, Erik, J.**; 3208 El Suyo Dr.,  
San Ramon, CA 94583 (US). **SCHENA, Bruce, M.**; 414  
Pope Street, Menlo Park, CA 94025 (US). **ROSENBERG,  
Louis, B.**; 5002 Felter Rd., San Jose, CA 95132 (US).

(74) Agents: **RIEGEL, James, R.** et al.; Immersion Corp., 801  
Fox Lane, San Jose, CA 95131 (US).

(81) Designated States (*national*): AE, AG, AL, AM, AT, AU,  
AZ, BA, BB, BG, BR, BY, BZ, CA, CH, CN, CO, CR, CU,  
CZ, DE, DK, DM, DZ, EC, EE, ES, FI, GB, GD, GE, GH,  
GM, HR, HU, ID, IL, IN, IS, JP, KE, KG, KP, KR, KZ, LC,  
LK, LR, LS, LT, LU, LV, MA, MD, MG, MK, MN, MW,  
MX, MZ, NO, NZ, OM, PH, PL, PT, RO, RU, SD, SE, SG,  
SI, SK, SL, TJ, TM, TN, TR, TT, TZ, UA, UG, UZ, VN,  
YU, ZA, ZM, ZW.

(84) Designated States (*regional*): ARIPO patent (GH, GM,  
KE, LS, MW, MZ, SD, SL, SZ, TZ, UG, ZM, ZW),  
Eurasian patent (AM, AZ, BY, KG, KZ, MD, RU, TJ, TM),  
European patent (AT, BE, CH, CY, DE, DK, ES, FI, FR,  
GB, GR, IE, IT, LU, MC, NL, PT, SE, TR), OAPI patent  
(BF, BJ, CF, CG, CI, CM, GA, GN, GQ, GW, ML, MR,  
NE, SN, TD, TG).

Published:  
— with international search report

For two-letter codes and other abbreviations, refer to the "Guidance Notes on Codes and Abbreviations" appearing at the beginning of each regular issue of the PCT Gazette.

(54) Title: HAPTIC INTERFACE FOR LAPTOP COMPUTERS AND OTHER PORTABLE DEVICES

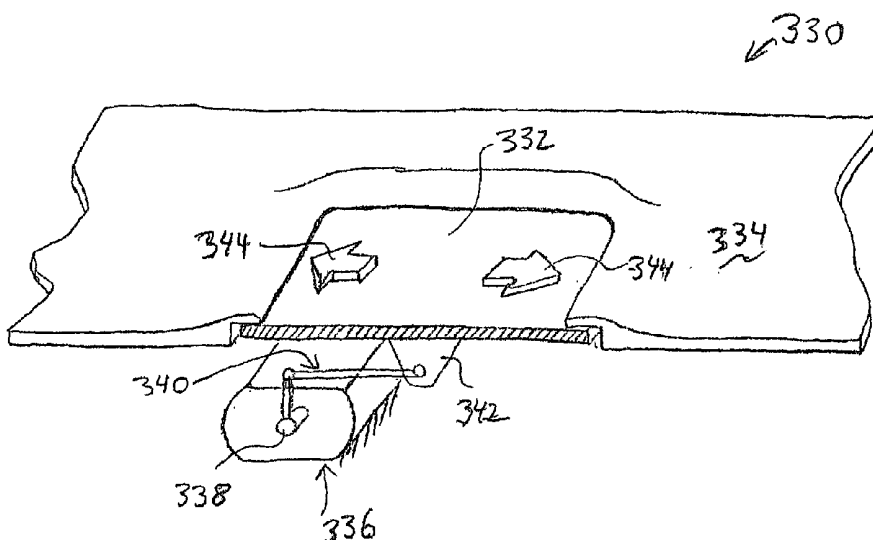

(57) Abstract: A haptic feedback touch control to provide input to a computer. A touch input device includes a planar touch surface that provides position information to a computer based on a location of user contact. The computer can position a cursor in a displayed graphical environment based at least in part on the position information, or perform a different function. At least one actuator (336) is also coupled to the touch input device and outputs a force to provide a haptic sensation to the user. The actuator (336) can move the touchpad (332) laterally, or a separate surface member can be actuated. A flat E-core actuator, piezoelectric actuator, or other types of actuators can be used to provide forces. The touch input device can include multiple different regions to control different computer functions.



WO 02/073587 A1

## **HAPTIC INTERFACE FOR LAPTOP COMPUTERS AND OTHER PORTABLE DEVICES**

### **BACKGROUND OF THE INVENTION**

The present invention relates generally to the interfacing with computer and mechanical devices by a user, and more particularly to devices used to interface with computer systems and electronic devices and which provide haptic feedback to the user.

Humans interface with electronic and mechanical devices in a variety of applications, and the need for a more natural, easy-to-use, and informative interface is a constant concern. In the context of the present invention, humans interface with computer devices for a variety of applications. One such application is interacting with computer-generated environments such as games, simulations, and application programs. Computer input devices such as mice and trackballs are often used to control a cursor within a graphical environment and provide input in these applications.

In some interface devices, force feedback or tactile feedback is also provided to the user, collectively known herein as "haptic feedback." For example, haptic versions of joysticks, mice, gamepads, steering wheels, or other types of devices can output forces to the user based on events or interactions occurring within the graphical environment, such as in a game or other application program.

In portable computer or electronic devices, such as laptop computers, mice have typically too large a workspace to be practical. As a result, more compact devices such as trackballs are often used. Currently, a more popular device for portable computers are "touchpads," which are small rectangular, planar pads provided near the keyboard of the computer. The touchpad senses the location of a pointing object by any of a variety of sensing technologies, such as capacitive sensors or pressure sensors that detect pressure applied to the touchpad. The user contacts the touchpad most commonly with a fingertip and moves his or her finger on the pad to move a cursor displayed in the graphical environment. In other embodiments, the user can operate a stylus in conjunction with the touchpad by pressing the stylus tip on the touchpad and moving the stylus. Touchscreens are similar devices used to input information on a sensing pad layered on a display screen, and are used in such devices as personal digital assistants (PDA's) and other portable electronic devices.

One problem with existing touchpads and screens is that there is no haptic feedback provided to the user. The user of a touchpad is therefore not able to experience haptic sensations that assist and inform the user of targeting and other control tasks within the

graphical environment. The touchpads of the prior art also cannot take advantage of existing haptic-enabled software running on the computer.

### **SUMMARY OF THE INVENTION**

The present invention is directed to haptic feedback planar touch controls used to provide input to a computer system. The control can be a touchpad provided on a portable computer, or can be a touch screen found on a variety of devices. The haptic sensations output on the touch control enhance interactions and manipulations in a displayed graphical environment or when controlling an electronic device.

More specifically, the present invention relates to a haptic feedback touch control for inputting signals to a computer and for outputting forces to a user of the touch control. The control includes a touch input device including an approximately planar touch surface operative to input a position signal to a processor of said computer based on a location of user contact on the touch surface. One or more actuators are coupled to the touch input device which can output a force to laterally move the touch input device approximately parallel to its surface to provide a haptic sensation to the user contacting it. The computer can position a cursor in a graphical environment displayed on a display device based on the position signal. The touch input device can be a separate touchpad or included as a touch screen.

In another embodiment, a haptic feedback touch control includes a touch input device including an approximately planar touch surface which inputs a position signal to a computer processor, a surface member located adjacent to the touch input device, where the user can contact the surface when pressing the touch input device, and an actuator coupled to the surface member. The actuator outputs a force on the surface member to provide a haptic sensation to the user. The surface member can be translated laterally, approximately in a plane parallel to the surface of the touch input device; for example, the surface member can be positioned over the touch input device and coextensive with the device surface, or the surface member can be positioned to a side of the touch input device such that the user touches the touch input device with one finger and touches the surface member with a different finger or palm. For example, the surface member can be positioned over a physical button that is located adjacent to said touch input device. Contact or inertial forces can be output on the surface member.

In another aspect of the present invention, an actuator providing a linear force output includes a ferromagnetic piece including a center pole located between two side poles, a coil wrapped around the center pole, a magnet adjacent to the center pole and side poles, and a backing plate coupled to the magnet, where the backing plate and magnet move with respect to

the ferromagnetic piece when current is flowed in the coil. Rollers can be positioned between the ferromagnetic piece and backing plate to allow the motion. A flexure can reduce the relative motion between plate and ferromagnetic piece in undesired directions and provide a spring centering force.

In another aspect, a haptic touch device includes a piezoelectric transducer coupled to a ground and including a metal diaphragm coupled to a ceramic element and a planar sensing element, such as a touchpad. A spacer is provided between the piezoelectric transducer and the planar sensing element, the metal diaphragm contacting the spacer. A spring element provides a spring restoring force to the planar sensing element.

In another aspect of the present invention, a method for providing haptic feedback to a touch input device includes receiving a position signal from the touch input device indicating a contact location on a surface where said user is pressing, and determining in which of a plurality of regions on the surface the contact location is positioned. An output force is associated with the user moving an object on or over the surface of the touch input device. A function can be associated with the region in which the contact location is positioned, such as rate control function of a value or moving a displayed cursor. The can be output when the user moves the object over a boundary to the contacted region from a different region of the touch input device.

The present invention advantageously provides haptic feedback to a planar touch control device of a computer, such as a touchpad or touch screen. The haptic feedback can assist and inform the user of interactions and events within a graphical user interface or other environment and ease cursor targeting tasks. Furthermore, the invention allows portable computer devices having such touch controls to take advantage of existing haptic feedback enabled software. The haptic touch devices disclosed herein are also inexpensive, compact and consume low power, allowing them to be easily incorporated into a wide variety of portable and desktop computers and electronic devices.

These and other advantages of the present invention will become apparent to those skilled in the art upon a reading of the following specification of the invention and a study of the several figures of the drawing.

### **BRIEF DESCRIPTION OF THE DRAWINGS**

FIGURE 1 is a perspective view of a laptop computer device including a haptic touchpad of the present invention;

FIGURE 2 is a perspective view of a remote control device including a touchpad of the present invention;

FIGURE 3 is a top plan view of a haptic touchscreen embodiment of the present invention;

FIGURE 4 is a block diagram of a haptic system suitable for use in the present invention;

FIGURE 5 is a perspective view of one embodiment of an actuator assembly suitable for use in an inertial embodiment of the present invention;

FIGURE 6 is a perspective view of the actuator assembly of Fig. 5 coupled to a touchpad;

FIGURE 7 is a perspective view of a separate palm surface providing inertial tactile sensations adjacent to a touchpad;

FIGURE 8a is a perspective view of a piezoelectric transducer suitable for use in providing inertial sensations in the present invention;

FIGURE 8b is a side elevational view of a piezoelectric transducer and structure of the present invention suitable for providing haptic sensations with a touch device;

FIGURE 9 is a perspective view of one embodiment of a translating surface member driven by linear actuators;

FIGURE 10 is a top plan view of another embodiment of a translating surface member driven by a rotary actuator;

FIGURE 11 is a perspective view of another embodiment of a translating surface member driven by a voice coil actuator;

FIGURE 12 is a perspective view of an embodiment of a translating surface adjacent to a touchpad;

FIGURE 13 is a perspective view of an embodiment of a touchpad translated in one direction by a rotary actuator;

FIGURE 14 is a perspective view of an embodiment of a touchpad translated in two directions by rotary actuators;

FIGURES 15a and 15b are perspective views of a first embodiment of a flat E-core actuator of the present invention suitable for translating a touchpad or a separate surface;

FIGURE 15c is a side view of the actuator of Figs. 15a-15b;

FIGURE 15d is a perspective view of the actuator of Figs. 15a-15b coupled to a touchpad;

FIGURES 16a and 16b are top and bottom perspective views of another embodiment of a flat E-core actuator of the present invention;

FIGURES 17a-17b are perspective and top views of surface-mounted E-core actuators of the present invention;

FIGURES 17c-17g are perspective and side views of the E-core actuators of Figs. 17a-17b; and

FIGURE 18 is a top plan view of an example of a haptic touchpad of the present invention having different control regions.

### **DETAILED DESCRIPTION OF PREFERRED EMBODIMENTS**

FIGURE 1 is a perspective view of a portable computer 10 including a haptic touchpad of the present invention. Computer 10 can be a portable or "laptop" computer that can be carried or otherwise transported by the user and may be powered by batteries or other portable energy source in addition to other more stationary power sources. Computer 10 preferably runs one or more host application programs with which a user is interacting via peripherals.

Computer 10 may include the various input and output devices as shown, including a display device 12 for outputting graphical images to the user, a keyboard 14 for providing character or toggle input from the user to the computer, and a touchpad 16 of the present invention. Display device 12 can be any of a variety of types of display devices; flat-panel displays are most common on portable computers. Display device 12 can display a graphical environment 18 based on application programs and/or operating systems that are running on the CPU of computer 10, such as a graphical user interface (GUI), that can include a cursor 20 that can be moved by user input, as well as windows 22, icons 24, and other graphical objects well known in GUI environments. Other graphical environments or images may also be displayed, e.g. a game, movie or other presentation, spreadsheet or other application program, etc.

Other devices may also be incorporated or coupled to the computer 10, such as storage devices (hard disk drive, DVD-ROM drive, etc.), network server or clients, game controllers, etc. In alternate embodiments, the computer 10 can take a wide variety of forms, including computing devices that rest on a tabletop or other surface, stand-up arcade game machines, other portable devices or devices worn on the person, handheld or used with a single hand of the user, etc. For example, host computer 10 can be a video game console, personal computer, workstation, a television "set top box" or a "network computer", or other computing or electronic device.

Touchpad device 16 of the present invention preferably appears externally to be similar to the touchpads of the prior art. In many embodiments disclosed herein, such a pad 16 includes a planar, rectangular (or other shaped) smooth surface that can be positioned below the keyboard 14 on the housing of the computer 10, as shown, or may be positioned at other areas of the housing. When the user operates the computer 10, the user may conveniently place a fingertip or other object on the touchpad 16 and move the fingertip to correspondingly move cursor 20 in the graphical environment 18.

In operation, the touchpad 16 inputs coordinate data to the main microprocessor(s) of the computer 10 based on the sensed location of an object on (or near) the touchpad. As with many touchpads of the prior art, touchpad 16 can use capacitive, resistive, or a different type of sensing. Capacitive touchpads typically sense the location of an object on or near the surface of the touchpad based on capacitive coupling between capacitors in the touchpad and the object. Resistive touchpads are typically pressure-sensitive, where the pressure of a finger, stylus, or other object against the pad causes conductive layers, traces, switches, etc. in the pad to electrically connect. Some resistive or other types of touchpads can detect the amount of pressure applied by the user and can use the degree of pressure for proportional or variable input to the computer 10. Resistive touchpads typically are at least partially deformable, so that when a pressure is applied to a particular location, the conductors at that location are brought into electrical contact. Such deformability can be useful in the present invention since it can potentially amplify the magnitude of output forces such as pulses or vibrations on the touchpad as used in the present invention. Forces can be amplified if a tuned compliant suspension is provided between an actuator and the object that is moved. Capacitive touchpads and other types of touchpads that do not require significant contact pressure may be better suited for the present invention in some embodiments, since excessive pressure on the touchpad may in some cases interfere with the motion of the touchpad for haptic feedback. Other types of sensing technologies can also be used in the touchpad. Herein, the term "touchpad" preferably includes the surface of the touchpad 16 as well as any sensing apparatus included in the touchpad unit.

Touchpad 16 can operate similarly to existing touchpads, where the speed of the fingertip on the touchpad correlates to the distance that the cursor is moved in the graphical environment. For example, if the user moves his or her finger quickly across the pad, the cursor is moved a greater distance than if the user moves the fingertip more slowly. If the user's finger reaches the edge of the touchpad before the cursor reaches a desired destination in that direction, then the user can simply move his or her finger off the touchpad, reposition the finger away from the edge, and continue moving the cursor. This is an "indexing" function similar to lifting a mouse off a surface to change the offset between mouse position and cursor. Furthermore, many touchpads can be provided with particular regions that are each assigned to particular functions that can be unrelated to cursor positioning. Such an embodiment is described in greater detail below with respect to Fig. 18. In some embodiments the touchpad 16 may also allow a user to "tap" the touchpad (rapidly touch and remove the object from the pad) in a particular location to provide a command. For example, the user can tap or "double tap" the pad with a finger while the controlled cursor is over an icon to select that icon.

In the present invention, the touchpad 16 is provided with the ability to output haptic feedback such as tactile sensations to the user who is physically contacting the touchpad 16. Various embodiments detailing the structure of the haptic feedback touchpad are described in greater detail below. Some embodiments may move a device housing or separate moving surface, not the touchpad itself.

Using one or more actuators coupled to the touchpad 16 or an associated surface, a variety of haptic sensations can be output to the user who is contacting the touchpad (or housing or separate surface). For example, jolts, vibrations (varying or constant amplitude), and textures can be output. Forces output to the user can be at least in part based on the location of the finger on the pad or the state of a controlled object in the graphical environment of the host computer 10, and/or independent of finger position or object state. Such forces output to the user are considered "computer-controlled" since a microprocessor or other electronic controller is controlling the magnitude and/or direction of the force output of the actuator(s) using electronic signals.

In other embodiments, the touchpad 16 can be provided in a separate housing that is connected to a port of the computer 10 via a cable or via wireless transmission and which receives force information from and sends position information to the computer 10. For example, Universal Serial Bus (USB), Firewire, or a standard serial bus can connect such a touchpad to the computer 10.

One or more buttons 26 can also be provided on the housing of the computer 10 to be used in conjunction with the touchpad 16. The user's hands have easy access to the buttons, each of which may be pressed by the user to provide a distinct input signal to the host computer



12. Typically, each button 26 corresponds to a similar button found on a mouse input device, so that a left button can be used to select a graphical object (click or double click), a right button can bring up a context menu, etc. In some embodiments, one or more of the buttons 26 can be provided with tactile feedback.

Furthermore, in some embodiments, one or more moveable portions 28 of the housing of the computer device 10 can be included which is contacted by the user when the user operates the touchpad 16 and which can provide haptic feedback. Having a moveable portion of a housing for haptic feedback is described in U.S. Patent Nos. 6,184,868 and 6,088,019. In some embodiments, both the housing can provide haptic feedback (e.g., through the use of an eccentric rotating mass on a motor coupled to the housing) and the touchpad 16 can provide separate haptic feedback. This can allow the host to control two different tactile sensations simultaneously to the user; for example, a vibration of a low frequency can be conveyed through the housing to the user and a higher frequency vibration can be conveyed to the user through the touchpad 16. Each other button or other control provided with haptic feedback can also provide tactile feedback independently from the other controls.

The host application program(s) and/or operating system preferably displays graphical images of the environment on display device 12. The software and environment running on the host computer 12 may be of a wide variety. For example, the host application program can be a word processor, spreadsheet, movie, video or computer game, drawing program, operating system, graphical user interface, simulation, Web page or browser that implements HTML or VRML instructions, scientific analysis program, virtual reality training program or application, or other application program that utilizes input from the touchpad 16 and outputs force feedback commands to the touchpad 16. For example, many games and other application programs include force feedback functionality and may communicate with the touchpad 16 using a standard protocol/drivers such as I-Force®, FEELit®, or Touchsense™ available from Immersion Corporation of San Jose, California.

The touchpad 16 can include circuitry necessary to report control signals to the microprocessor of the host computer 10 and to process command signals from the host's microprocessor. For example, appropriate sensors (and related circuitry) are used to report the position of the user's finger on the touchpad 16. The touchpad device also includes circuitry that receives signals from the host and outputs tactile sensations in accordance with the host signals using one or more actuators. Some touchpads may be integrated with a printed circuit board (PCB) that includes some of these components and circuitry. In some embodiments, a separate, local microprocessor can be provided for the touchpad 16 to both report touchpad sensor data to the host and/or to carry out force commands received from the host, such commands including, for example, the type of haptic sensation and parameters describing the

commanded haptic sensation. Alternatively, the touchpad microprocessor can simply pass streamed data from the main processor to the actuators. The term "force information" can include both commands/parameters and/or streamed data. The touchpad microprocessor can implement haptic sensations independently after receiving a host command by controlling the touchpad actuators; or, the host processor can maintain a greater degree of control over the haptic sensations by controlling the actuators more directly. In other embodiments, logic circuitry such as state machines provided for the touchpad 16 can handle haptic sensations as directed by the host main processor. Architectures and control methods that can be used for reading sensor signals and providing haptic feedback for a device are described in greater detail in U.S. Patent No. 5,734,373.

In existing touchpad embodiments, such as those manufactured by Synaptics Corp., particular characteristics and features are provided. The standard surface material for a touchpad is textured Mylar, and typically any non-conductive object can be used on the touchpad surface and be detected, though textured surfaces are better when a user's finger is used to point. The touchpad can also sense through thin overlays. There is typically space available for the additional of haptic feedback components; for example, on a 40 x 60 touchpad, over half of the board can be available for haptic circuitry.

Many touchpads include a "palm check" feature, which allows the laptop to sense whether the user is contacting the touchpad with a finger or with a palm or other part of the hand. Since the user may only be resting his or her palm and not be intending to provide input, the palm check feature would ignore input that is determined to be provided by a user's palm. Basically, the palm check feature computes the contact area made by the conductive object (finger, palm, arm, etc.). If the contact area exceeds a certain threshold, the contact is rejected. This feature can be turned off in many embodiments.

FIGURE 2 is a perspective view of another embodiment of a device 30 which can include the active touchpad 16 of the present invention. The device can be a handheld remote control device 30, which the user grasps in one hand and manipulates controls to access the functions of an electronic device or appliance remotely by a user (such as a television, video cassette recorder or DVD player, audio/video receiver, Internet or network computer connected to a television, etc.). For example, several buttons 32 can be included on the remote control device 30 to manipulate functions of the controlled apparatus. A touchpad 16 can also be provided to allow the user to provide more sophisticated directional input. For example, a controlled apparatus may have a selection screen in which a cursor may be moved, and the touchpad 16 can be manipulated to control the cursor in two dimensions. The touchpad 16 includes the ability to output haptic sensations to the user as described herein, based on a

controlled value or event. For example, a volume level passing a mid-point or reaching a maximum level can cause a pulse to be output to the touchpad and to the user.

In one application, the controlled apparatus can be a computer system such as Web-TV from Microsoft Corp. or other computing device which displays a graphical user interface and/or web pages accessed over a network such as the Internet. The user can control the direction of the cursor by moving a finger (or other object) on the touchpad 16. The cursor can be used to select and/or manipulate icons, windows, menu items, graphical buttons, slider bars, scroll bars, or other graphical objects in a graphical user interface or desktop interface. The cursor can also be used to select and/or manipulate graphical objects on a web page, such as links, images, buttons, etc. Other force sensations associated with graphical objects are described below with reference to Fig. 18.

FIGURE 3 is a top plan view of another computer device embodiment 50 that can include any of the embodiments of haptic devices of the present invention. Device 50 is in the form of a portable computer device such as "personal digital assistant" (PDA), a "pen-based" computer, "web pad," "electronic book", or similar device (collectively known as a "personal digital assistant" (PDA) herein). Those devices which allow a user to input information by touching a display screen or readout in some fashion are relevant to the present invention, as well as devices allowing button input. Such devices can include the Palm Pilot® from 3Com Corp. or similar products, pocket-sized computer devices from Casio, Hewlett-Packard, or other manufacturers, E-books, cellular phones or pagers having touch screens, laptop computers with touch screens, etc.

In one embodiment of a device 50, a display screen 52 positioned adjacent a housing 54 may cover a large portion of the surface of the computer device 50. Screen 52 is preferably a flat-panel display as is well known to those skilled in the art and can display text, images, animations, etc.; in some embodiments screen 52 is as functional as any personal computer screen. Display screen 52 can be a "touch screen" that includes sensors which allow the user to input information to the computer device 50 by physically contacting the screen 50 (i.e. it is another form of planar "touch device" similar to the touchpad 16 of Fig. 1). For example, a transparent sensor film can be overlaid on the screen 50, where the film can detect pressure from an object contacting the film. The sensor devices for implementing touch screens are well known to those skilled in the art.

The user can select graphically-displayed buttons or other graphical objects by pressing a finger or a stylus to the screen 52 at the exact location where the graphical object is displayed. Furthermore, some embodiments allow the user to "draw" or "write" on the screen by displaying graphical "ink" images 56 at locations where the user has pressed a tip of a stylus, such as stylus 57, or a finger or other object. Handwritten characters can be recognized by

software running on the device microprocessor as commands, data, or other input. In other embodiments, the user can provide input additionally or alternatively through voice recognition, where a microphone on the device inputs the user's voice which is translated to appropriate commands or data by software running on the device. Physical buttons 58 can also be included in the housing of the device 50 to provide particular commands to the device 50 when the buttons are pressed. Many PDA's are characterized by the lack of a standard keyboard for character input from the user; rather, an alternative input mode is used, such as using a stylus to draw characters on the screen, voice recognition, etc. However, some PDA's also include a fully-functional keyboard as well as a touch screen, where the keyboard is typically much smaller than a standard-sized keyboard. In yet other embodiments, standard-size laptop computers with standard keyboards may include flat-panel touch-input display screens, and such screens (similar to screen 12 of Fig. 1) can be provided with haptic feedback according to the present invention.

In some embodiments of the present invention, the touch screen 52 may provide haptic feedback to the user similarly to the touchpad 16 described in previous embodiments. One or more actuators can be coupled to the touchscreen, or movable surfaces near the touchscreen, in a manner similar to the embodiments described below. The user can experience the haptic feedback through a finger or a held object such as a stylus 57 that is contacting the screen 52.

The touch screen 52 can be coupled to the housing 54 of the device 50 by one or more spring or compliant elements, such as helical springs, leaf springs, flexures, or compliant material (foam, rubber, etc.), to allow motion of the screen approximately along the z-axis, thereby providing haptic feedback. The screen can also be provided with flexures or other couplings allowing side-to-side (x and/or y) motion, similar to the appropriate embodiments described below.

FIGURE 4 is a block diagram illustrating a haptic feedback system suitable for use with any of the described embodiments of the present invention. The haptic feedback system includes a host computer system 74 and interface device 72.

Host computer system 74 preferably includes a host microprocessor 100, a clock 102, a display screen 76, and an audio output device 104. The host computer also includes other well known components, such as random access memory (RAM), read-only memory (ROM), and input/output (I/O) electronics (not shown).

As described above, host computer 74 can be a personal computer such as a laptop computer, and may operate under any well-known operating system. Alternatively, host computer system 74 can be one of a variety of home video game console systems commonly connected to a television set or other display, such as systems available from Nintendo, Sega,

Sony, or Microsoft. In other embodiments, host computer system 74 can be an appliance, “set top box”, or other electronic device to which the user can provide input. Computer 74 can also be a portable, hand-held computer such as a PDA, or can be a vehicle computer, stand-up arcade game, workstation, etc.

Host computer 74 preferably implements a host application program with which a user is interacting via interface device 72 which includes haptic feedback functionality. For example, the host application program can be a video game, word processor or spreadsheet, Web page or browser that implements HTML or VRML instructions, scientific analysis program, movie player, virtual reality training program or application, or other application program that may utilize input of mouse 12 and which outputs haptic feedback commands to the device 72. Herein, for simplicity, operating systems such as Windows™, MS-DOS, MacOS, Unix, Palm OS, etc. are also referred to as “application programs.” Herein, computer 74 may be referred as providing a “graphical environment,” which can be a graphical user interface, game, simulation, or other visual environment and can include graphical objects such as icons, windows, game objects, etc. Suitable software drivers which interface such software with computer input/output (I/O) devices are available from Immersion Corporation of San Jose, California.

Display device 76 can be included in host computer 74 and can be a standard display screen (LCD, CRT, plasma, flat panel, etc.), 3-D goggles, or any other visual output device. Audio output device 104, such as speakers, is preferably coupled to host microprocessor 100 to provide sound output to user. Other types of peripherals can also be coupled to host processor 100, such as storage devices (hard disk drive, CD ROM drive, floppy disk drive, etc.) other input and output devices.

Interface device 72 is coupled to the computer 74 by a bus 80, which communicates signals between device 72 and computer 74 and may also, in some embodiments, provide power to the device 72. In other embodiments, signals can be sent between device 72 and computer 74 by wireless transmission/reception. In some embodiments, the power for the actuator can be supplemented or solely supplied by a power storage device provided on the device, such as a capacitor or one or more batteries. The bus 80 can be bi-directional to send signals in either direction between host 74 and device 72. Bus 80 can be a serial interface bus, such as an RS232 serial interface, RS-422, Universal Serial Bus (USB), MIDI, or other protocols well known to those skilled in the art; or a parallel bus or wireless link.

Device 72 may be a separate device from host 74 with its own housing, or may be integrated with the host computer housing, as in the laptop computer of Fig. 1. Device 72 can include or be associated with a dedicated local processor 110. Processor 110 is considered local to device 12, where “local” herein refers to processor 110 being a separate processor from any

host processors in host computer system 14. "Local" also may refer to processor 110 being dedicated to haptic feedback and sensor I/O of device 12. Processor 110 can be provided with software instructions (e.g., firmware) to wait for commands or requests from computer host 74, decode the command or request, and handle/control input and output signals according to the command or request. In addition, processor 110 can operate independently of host computer 74 by reading sensor signals and calculating appropriate forces from those sensor signals, time signals, and stored or relayed instructions selected in accordance with a host command. Suitable microprocessors for use as local processor 110 include lower-end microprocessors as well as more sophisticated force feedback processors such as the Immersion Touchsense Processor. Processor 110 can include one microprocessor chip, multiple processors and/or co-processor chips, digital signal processor (DSP) capability, and/or logic, state machines, an ASIC, etc.

Processor 110 can receive signals from sensor 112 and provide signals to actuator 88 in accordance with instructions provided by host computer 74 over bus 80. For example, in a local control embodiment, host computer 74 provides high level supervisory commands to processor 110 over bus 20 (such as a command identifier and one or more parameters characterizing the tactile sensation), and processor 110 decodes the commands and manages low level force control loops to sensors and the actuator in accordance with the high level commands and independently of the host computer 74. This operation is described in greater detail in US Patent 5,734,373. In the host control loop, force commands are output from the host computer to processor 110 and instruct the processor to output a force or force sensation having specified characteristics. The local processor 110 reports data to the host computer, such as locative data that describes the position of the device in one or more provided degrees of freedom. The data can also describe the states of buttons, switches, etc. The host computer uses the locative data to update executed programs. In the local control loop, actuator signals are provided from the processor 110 to an actuator 88 and sensor signals are provided from the sensor 112 and other input devices 118 to the processor 110. Herein, the term "tactile sensation" refers to either a single force or a sequence of forces output by the actuator 18 which provide a sensation to the user. For example, vibrations, a single jolt, or a texture sensation are all considered tactile sensations. The processor 110 can process inputted sensor signals to determine appropriate output actuator signals by following stored instructions. The processor may use sensor signals in the local determination of forces to be output on the user object, as well as reporting locative data derived from the sensor signals to the host computer.

In yet other embodiments, other hardware instead of processor 110 can be provided locally to device 72 to provide functionality similar to processor 110. For example, a hardware state machine incorporating fixed logic can be used to provide signals to the actuator 88 and receive sensor signals from sensors 112, and to output tactile signals.

In a different, host-controlled embodiment, host computer 74 can provide low-level force commands over bus 20, which are directly transmitted to the actuator 18 via processor 110 or other circuitry if there is no processor 110. Host computer 14 thus directly controls and processes all signals to and from the device 72, e.g. the host computer directly controls the forces output by actuator 88 and directly receives sensor signals from sensor 112 and input devices 118. Other embodiments may employ a “hybrid” organization where some types of forces (e.g. closed loop effects) are controlled purely by the local microprocessor, while other types of effects (e.g., open loop effects) may be controlled by the host.

Local memory 122, such as RAM and/or ROM, is preferably coupled to processor 110 in device 72 to store instructions for processor 110 and store temporary and other data. Memory 122 can also or alternatively be included on the processor 110. In addition, a local clock 124 can be coupled to the processor 110 to provide timing data.

Sensors 112 sense the position or motion (e.g. an object on a touchpad) in desired degrees of freedom and provides signals to processor 110 (or host 74) including information representative of the position or motion. Sensors suitable for detecting motion include capacitive or resistive sensors in a touchpad, contact sensors in a touchscreen, etc. Other types of sensors can also be used. Optional sensor interface 114 can be used to convert sensor signals to signals that can be interpreted by the processor 110 and/or host computer system 14.

Actuator(s) 88 transmits forces to the housing, manipulandum, buttons, or other portion of the device 72 in response to signals received from processor 110 and/or host computer 14. Device 72 preferably includes one or more actuators which are operative to produce forces on the device 72 (or a component thereof) and haptic sensations to the user. The actuator(s) are “computer-controlled”, e.g., the force output from the actuators is ultimately controlled by signals originating from a controller such as a microprocessor, ASIC, etc. Many types of actuators can be used, including rotary DC motors, voice coil actuators, moving magnet actuators, E core actuators, pneumatic/hydraulic actuators, solenoids, speaker voice coils, piezoelectric actuators, passive actuators (brakes), etc. Some preferred actuator types are described below. Actuator interface 116 can be optionally connected between actuator 88 and processor 110 to convert signals from processor 110 into signals appropriate to drive actuator 88. Interface 116 can include power amplifiers, switches, digital to analog controllers (DACs), analog to digital controllers (ADCs), and other components, as is well known to those skilled in the art.

In some of the implementations herein, the actuator has the ability to apply short duration force sensation on the housing or manipulandum of the device, or via moving an inertial mass. This short duration force sensation can be described as a “pulse.” The “pulse” can be directed substantially along a particular direction in some embodiments. In some

embodiments, the magnitude of the “pulse” can be controlled; the sense of the “pulse” can be controlled, either positive or negative biased; a “periodic force sensation” can be applied and can have a magnitude and a frequency, e.g. the periodic sensation can be selectable among a sine wave, square wave, saw-toothed-up wave, saw-toothed-down, and triangle wave; an envelope can be applied to the period signal, allowing for variation in magnitude over time. The wave forms can be “streamed” from the host to the device, , or can be conveyed through high level commands that include parameters such as magnitude, frequency, and duration.

Other input devices 118 can be included in device 72 and send input signals to processor 110 or to host 74 when manipulated by the user. Such input devices include buttons, dials, switches, scroll wheels, knobs, or other controls or mechanisms. Power supply 120 can optionally be included in device 72 coupled to actuator interface 116 and/or actuator 18 to provide electrical power to the actuator. Alternatively, power can be drawn from a power supply separate from device 72, or power can be received across bus 80. Also, received power can be stored and regulated by device 72 (and/or host 74) and thus used when needed to drive actuator 88 or used in a supplementary fashion.

The interface device 12 can be any of a variety of types; some embodiments are described further below. The touchpads or touchscreen described herein can be provided on a variety of types of devices, such as gamepads, joysticks, steering wheels, touchpads, spherical controllers, finger pads, knobs, track balls, remote control device, cell phone, personal digital assistant, etc.

### Specific Embodiments

The present invention presents a variety of embodiments in which haptic feedback is provided to a user of a laptop computer or other portable computing device, and/or to the user of any computing device having a touchpad or similar input device.

Some embodiments are based on displacing the skin of a user’s finger when it is in contact with a touchpad. These embodiments deliver high fidelity sensations while offering a good correlation between input and output right at the user’s fingertip. Actuator and linkage solutions are described to drive any of the translation embodiments. Other embodiments are based on the stimulation of palm surfaces of the user that are normally in contact with the laptop computer 10. These surfaces can provide haptic sensations based on inertially coupled forces or translation of the palm surfaces. Translations of surfaces in plane with the upper surface of the touchpad or laptop (i.e. in the X and/or Y axes) are as effective at conveying haptic information as vibrations or displacements in the Z axis (those normal to the touchpad or



laptop upper surface). This can be important when the volumetric constraints of a laptop are considered.

In many of the embodiments described herein, it is also advantageous that contact of the user is detected by a touch input device. Since haptic feedback need only be output when the user is contacting the touch device, this detection allows haptic feedback to be stopped (actuators “turned off”) when no objects are contacting the touch input device. This feature can conserve battery power for portable devices. If a local touch device microprocessor (or similar circuitry) is being used in the computer, such a microprocessor can turn off actuator output when no user contact is sensed, thus alleviating the host processor of additional computational burden until touch is again detected, when the actuator output is resumed.

In many preferred embodiments, haptics are added to a laptop computer or other device in a way that does not force the user to relearn how to control the laptop or force the manufacturer to stretch design and manufacturing too far from existing designs to provide the haptic content. For example, in laptop embodiments, as the user moves his or her finger across the touchpad, a cursor displayed on the laptop screen is correspondingly moved. Haptic effects can be output on the touchpad or other laptop component contacted by the user when the cursor interacts with a graphical object or area, when an event occurs, etc. In other applications, haptic effects can be output when events or interactions occur in a game or other application running on the laptop. Many types of actuators, sensors, linkages, amplification transmissions, etc. can be used with the present invention.

A touchpad surface, as manufactured currently, typically is coupled to a printed circuit board (PCB) that includes necessary electronics and standard connections for connecting and operating the touchpad in a laptop. Thus, when forces are applied to the touchpad, they are also applied to the PCB that is often directly coupled to the touchpad, e.g. underneath the touchpad.

The embodiments herein are designed with particular guidelines and characteristics. For example, the particular haptic experiences that feel compelling in a certain embodiment, the location where the tactile content is focused or located physically, the spatial correlation of the haptic feedback with the pointing of the user’s finger on the touchpad, e.g. the feedback can be right under the finger, or originate somewhere in the case/housing of the laptop, the required force strength and power for compelling feedback, the way the user interacts with the device and effect on quality and content of the feedback (angle of finger contact, etc), and which actuators and mechanisms that can fit into the laptop form factor/housing are most desirable.

Preferably, existing haptic feedback software and drivers can be used with the embodiments described herein, such as TouchSense software from Immersion Corp. A

standardized module, such as a particular touchpad, that works for many different types of products is desirable, such as PDAs, laptops, cell phones, and remote controls.

The focus of these inventive embodiments is primarily on tactile feedback implementations, not kinesthetic force feedback embodiments. As described herein, there are two basic classes of tactile feedback as applied to the present invention: inertial haptic feedback and moving contact haptic feedback. Inertial feedback is generated using inertially coupled vibrations and is based on moving an inertial mass that is coupled to the housing/user through a compliant flexure, where the mass motions cause inertial vibrations in a surface contacted by the user. Moving contact feedback relates to directly moving a surface or member, with respect to an earth ground, against the user and usually is generated by creating small displacements of the user's skin.

The distinction between inertial and moving contact feedback can be made in terms of the actual mechanism used to provide information to the user. Both inertial and tactile stimulation cause displacement of the hand or finger tissue; the inertial feedback is coupled through some enclosure by the transmissibility of that enclosure and the compliance of whatever holds the enclosure. Moving contact feedback refers to a mechanism that is more direct in how it stimulates the user's tissue. Examples would be tactile dots or surfaces that shear the skin of the finger to cause sensation by locally deforming the finger or palm tissue. This distinction is made for the purposes of classifying two types of embodiments described below: inertial and surface translation.

A novel actuator, referred to as Flat-E herein, is described below and can be used in all of the embodiments herein and represents a class of very low profile, power efficient, high performance, planar actuators. A Flat-E actuator can achieve acceptable performance levels and approach the limited volume and form factor required for laptop and other device applications.

### Inertial Embodiments

These embodiments move an inertial mass to cause inertial haptic feedback to the user, which is typically transmitted through an enclosure or mechanism such as a housing or other surface. In many cases, inertial mass does not impact any surfaces in its travel, although such impacts can alternatively be used to provide additional haptic effects.

FIGURE 5 is a perspective view of one embodiment 150 of an actuator assembly that can be used to provide inertial haptic sensations for touchpads and housings of devices of the present invention. Actuator assembly 150 includes a grounded flexure 160 and an actuator 155.

The flexure 160 can be a single, unitary piece made of a material such as polypropylene plastic (“living hinge” material) or other flexible material. Flexure 160 can be grounded to the housing of the device 12, for example, at portion 161.

Actuator 155 is coupled to the flexure 160. The housing of the actuator is coupled to a receptacle portion 162 of the flexure 160 which houses the actuator 155 as shown. A rotating shaft 164 of the actuator is coupled to the flexure 160 in a bore 165 of the flexure 160 and is rigidly coupled to a central rotating member 170. The rotating shaft 164 of the actuator is rotated about an axis A which also rotates member 170 about axis A. Rotating member 170 is coupled to a first portion 172a of an angled member 171 by a flex joint 174. The flex joint 174 is made very thin in the dimension it is to flex so that the flex joint 174 will bend when the rotating portion 170 moves the first portion 172a approximately linearly. The first portion 172a is coupled to the grounded portion 180 of the flexure by a flex joint 178 and the first portion 172a is coupled to a second portion 172b of the angled member by flex joint 182. The second portion 172b, in turn, is coupled at its other end to the receptacle portion 162 of the flexure by a flex joint 184.

The angled member 171 that includes first portion 172a and second portion 172b moves linearly along the x-axis as shown by arrow 176. In actuality, the portions 172a and 172b move only approximately linearly. When the flexure is in its origin position (rest position), the portions 172a and 172b are preferably angled as shown with respect to their lengthwise axes. This allows the rotating member 170 to push or pull the angled member 171 along either direction as shown by arrow 176.

The actuator 155 is operated in only a fraction of its rotational range when driving the rotating member 170 in two directions, allowing high bandwidth operation and high frequencies of pulses or vibrations to be output. A flex joint 192 is provided in the flexure portion between the receptacle portion 162 and the grounded portion 180. The flex joint 192 allows the receptacle portion 162 (as well as the actuator 155, rotating member 170, and second portion 172b) to move approximately linearly in the z-axis in response to motion of the portions 172a and 172b. A flex joint 190 is provided in the first portion 172a of the angled member 171 to allow the flexing about flex joint 192 in the z-direction to more easily occur.

By quickly changing the rotation direction of the actuator shaft 164, the actuator/receptacle can be made to oscillate along the z-axis and create a vibration on the housing with the actuator 155 acting as an inertial mass. In addition, the flex joints included in flexure 160, such as flex joint 192, act as spring members to provide a restoring force toward the origin position (rest position) of the actuator 155 and receptacle portion 172. In some embodiments, the stops can be included in the flexure 160 to limit the motion of receptacle portion 122 and actuator 155.

Other embodiments can provide other types of actuator assemblies to provide inertial sensations, such as a flexure that moves a separate inertial mass instead of the actuator itself. Or, an eccentric mass coupled to a rotating shaft of an actuator can be oscillated to provide rotational inertial tactile sensations to the housing. The eccentric mass can be unidirectionally driven or bidirectionally driven. Other types of actuator assemblies may also be used, such as a linear voice coil actuator, solenoid, moving magnet actuator, etc.

In one embodiment, an actuator assembly such as described above may be coupled to any of various locations of a laptop housing or other device housing and used to vibrate parts of the housing, relying on the transmission of vibrations through the product housing by the remotely mounted actuator module. The actuator assembly can be attached to different areas of the laptop housing or components to provide inertial haptic feedback when the inertial mass is oscillated.

The experience of the user may vary depending on the precise location of the actuator assembly on the laptop and with different tactile effects that are output. Locations for the coupling of the actuator assembly include the housing bottom, side, or front, a surface engaged by the user's palm when operating the device, an area adjacent to the touchpad or touchscreen, or coupled to the touchpad or touchscreen. An effective location may be the touchpad itself (e.g. coupling the actuator assembly to the bottom of the touchpad). In some embodiments, if the touchpad is rectangular, more compliance may be achieved along the long axis of the touchpad.

In general, haptic content is received by the user over a limited frequency range by attaching the actuator assembly to a location on the laptop. A particular location most effective for transmitting vibrations can be determined by experimentation, for example.

In many cases, the output of several types of haptic effects can be faint and muddy to the user, and effects having predominantly higher frequencies may be more perceptible. One effective tactile effect for this embodiment is a relatively high frequency "ringing" effect. Sympathetic vibrations in the laptop case and the touchpad may amplify these vibrations. An actuator designed to resonate at a certain ideal frequency may be used to present a wide spectrum of frequencies by amplitude modulation techniques. For example, a compelling 25 Hz square wave can be generated by modulating a 250 Hz natural frequency generated by a tuned resonant actuator such as a large piezo ceramic resonator (see Figs. 8a-8b). Such modulation schemes may rely on the actuator being tuned to the environment it lives in and the object it must drive. Some type of vibration isolation system can be used in some embodiments to keep the energy confined to the haptic module as opposed to allowing the energy to dissipate off into sympathetic modes in other portions of the laptop computer or other device.

FIGURE 6 is a perspective view of another embodiment, in which a touchpad module can be suspended in a compliant support structure and can be coupled to a harmonic source and vibrated along the Z-axis. In this example, a touchpad 200 can be moved with an actuator assembly 202 that moves the touchpad surface in the Z-axis, perpendicular to the surface of the touchpad. The touchpad can be coupled to the laptop housing 204 by one or more layers or supports of foam, rubber, or other compliant material, where a strip 206 of foam provided around the perimeter of the touchpad between the touchpad 200 and the housing 204 as shown in Fig. 6. The actuator assembly 202 can be coupled to the bottom of the touchpad assembly (or to another location) so that when the inertial mass is oscillated, the oscillations transfer to the touchpad and allow it move in the Z-direction with respect to the laptop housing 204. For example, the actuator assembly can be bonded directly to the bottom of the touchpad PCB. A floating assembly of a touchpad and a bezel (surface surrounding the touchpad) can alternatively be moved, as opposed to just moving the touchpad module in the Z-axis.

In another embodiment, a stand-alone touchpad device can be used, where the touchpad is housed in a separate housing and communicates with the laptop or other device via wires or transmissions. In one embodiment, the stand-alone touchpad device can be attached to a palm pad (or other member), with the actuator assembly coupled to the pad. When the inertial mass of the actuator assembly is oscillated, the inertial sensations are transmitted through the member to the touchpad, i.e. this effectively provides inertial coupling from the actuator assembly to the touchpad surface. A foam layer (or other compliant layer) can be coupled between the pad and ground to provide compliance and allow the pad and touchpad to move inertially. This embodiment may feel more compelling than the embodiments in which the actuator assembly is mounted to the laptop near or on the built-in touchpad, possibly due to the compliance of the foam which can allow stronger sensations to be output.

The entire touchpad can be provided with haptic sensations as a single unitary member; or, in other embodiments, individually-moving portions of the pad can each be provided with its own haptic feedback actuator and related transmissions so that haptic sensations can be provided for only a particular portion. For example, some embodiments may include a touchpad having different portions that may be flexed or otherwise moved with respect to other portions of the touchpad.

In another embodiment, the surface around or adjacent to the touchpad is coupled to harmonic vibration source (e.g., actuator assembly) and vibrates in one or more axes. For example, palm rest surfaces may be driven by an inertial actuator assembly housed in the laptop. FIGURE 7 is a perspective view of one example of an inertially-driven palm rest surface. A laptop computer 210 includes a touchpad 212 that functions like a typical touchpad. A palm rest surface 214 is positioned adjacent to the touchpad 212, where the surface 214 can

be attached to the laptop housing on a layer of resilient open cell foam or other compliant material. In some embodiments, the surface 214 can be textured with divots and/or bumps to allow a stronger contact by the user to the surface. An actuator assembly 216 is coupled to the palm rest surface 214; in the embodiment shown, the assembly 216 is coupled to the underside of the surface 214. The assembly can be any of the actuator assemblies described above. For example, the actuator assembly 216 can provide z-axis oscillations to the palm rest surface 214.

The user preferably rests a palm and/or some fingers on the palm rest surface 214 while the user is using the touchpad 212 with a pointing finger(s). Thus, the user is able to feel haptic sensations through the palm rest surface while operating the touchpad. Alternatively, one hand of the user is used to point and operate the touchpad, while the other hand rests on the palm surface 214 and senses haptic feedback. The palm surfaces are implemented as practically unavoidable contact surfaces and consequently a user is not likely to miss very many haptic events while using the touchpad. In some embodiments, how hard the user rests the palms on the surface can make a slight difference in perceived magnitude over the useful bandwidth, and may be a result of stiffness and mass of the particular device used. The stiffness of the coupling of the palm surface with the housing can be adjusted for a particular feel in different embodiments.

In a related embodiment, the actuator assembly can be mounted in different areas. For example, the actuator assembly can be attached to the bottom of an extension of a palm rest surface made of textured material mounted on a layer of resilient open cell foam or other compliant material.

In other embodiments, the palm surface can be translated in the X and/or Y directions, similarly to the touchpad translation described below. The inertial actuator assembly could be used to force the translation, or a different type of actuator, e.g. high actuator authority and fairly high stiffness in the translation mode to avoid unintentional hard stop limiting distortion, etc. The translating palm surface can be suitable for a flat actuator so that the assembly can be integrated into the laptop housing; flat actuators are described below.

FIGURE 8a is a perspective view of an actuator that can be used in another embodiment of an inertial haptic feedback device of the present invention. In this embodiment, a higher frequency mechanical oscillator, mechanically coupled to the touchpad, is modulated. One example of such an implementation may include a large-diameter commercially available thin piezoelectric transducer 230, e.g., 60mm in diameter with natural frequencies of 300 to 400 Hz when supported peripherally. The piezoelectric transducer preferably includes a thin diaphragm (sheet) of metal 231. One embodiment may include an added mass 232 at the ceramic center of the piezo diaphragm in order to add inertial mass and lower the natural frequency to achieve stronger inertial tactile sensations from the oscillating mass. The outer periphery of transducer

230 can be grounded and the mass 232 can oscillate normal to the disc surface to create inertial haptic sensations to the housing to which the transducer is attached.

Actuator 230 can function as a harmonic oscillator that runs at a relatively high frequency that transmits sensations to the hand or part of the laptop to which it is attached. Amplitude modulation (envelope control) may be used to produce a wider haptic spectrum than the single fundamental drum mode. Large diameter piezo drivers are available, for example, from Kingstate of Taiwan. Differently sized discs can also be used.

To provide the desired haptic sensations, a large piezo transducer or “buzzer” should provide large sustainable displacements (accelerations) of the mass and the carrier frequency (the frequency at which it oscillates) should be modulated with the haptic signal. Some electronics may be needed to operate this type of actuator. A high voltage supply can be generated from 5 volts. An oscillation circuit, e.g., self exciting, can drive the element. There can be a gating feature to start and stop the oscillation as well as a proportional control to allow modulation of the amplitude of the output. An all-digital implementation may be provided by gating the oscillator on and off.

FIGURE 8b is a side elevational view of another embodiment 234 of a piezoelectric transducer providing haptic feedback, where the transducer applies (non-inertial) vibrations directly to the touchpad (or touchscreen) along the z-axis. A housing 236 of the laptop or other device can include bezels which overlay a touchpad member 238, which the user physically contacts to provide input to a computer or processor. The touchpad member 238 can include the required electronics to interface the touchpad with other electronic components. The touchpad member 238 can rest on a spacer 240 having a particular mass chosen to allow efficient haptic output. The spacer 240 rests on the edge of a piezo metal diaphragm 231, which is part of the piezo transducer, and where an electrical lead 241 is coupled between the diaphragm 231 and a signal source 246. The piezo ceramic element 242, also part of the piezo transducer, is coupled to the metal diaphragm 231 and an electrical lead 243 is coupled between the element 242 and the signal source 246. A conductive electrode is plated on the ceramic element 242. A contact pad 248 is positioned between the element 242 and a bottom housing 250, where the contact pad is rigidly coupled to both ceramic element 242 and housing 250. The contact pad 248 is made small so that the diaphragm 231 will have increased bending, resulting in greater acceleration and stronger haptic effects. The bottom housing 250 can include a printed circuit board (PCB), for example. One or more preloaded spring elements 252 couple the touchpad member 238 to the bottom housing 250, e.g. leaf springs, helical springs, etc.

In operation, the piezo transducer moves along the z-axis when an oscillating current from signal source 246 is flowed through the diaphragm 231 and the ceramic element 242.

Thus, spacer 240 is provided only at the edges of the diaphragm 231 to allow the inner portion of the diaphragm and the ceramic element 242 to move, and the ceramic element pushes against the bottom housing 250, causing the diaphragm 231 to push against the spacer 240, which in turn pushes against the touchpad element 238. This pushes the touchpad element up, and the spring elements 252 provide a spring return force on the touchpad so that it will return to its neutral position. When the piezo transducer similarly moves in the opposite direction, as directed by the oscillating signal, this moves the touchpad element 238 down toward the bottom housing 250. The touchpad element thus oscillates along the z-axis and provides haptic sensations to the user contacting the touchpad element.

In some embodiments, the components of the touchpad embodiment 234 can be chosen to provide more effective haptic sensations. For example, if the piezo transducer oscillates at close to a natural frequency of the mechanical system (including the transducer itself), then stronger forces and more effective haptic sensations can be output. The natural frequency of this moving mechanical system can be approximately expressed as the square root of the expression  $k_1 + k_2$  divided by  $m$ , as shown below:

$$f_n \approx \sqrt{(k_1 + k_2 / m)}$$

where  $f_n$  is the natural frequency,  $k_1$  is the spring constant of the metal diaphragm 231 of the piezo transducer,  $k_2$  is the spring constant of the spring elements 252, and  $m$  is the total mass of the spacer 240, the touchpad 238, and the parts of the suspension attached to the touchpad. This mass, as well as the spring constants, can be selected to provide a desirable low natural frequency, such as about 120 Hz or less, which tends to cause effective haptic sensations. The spacer 240 can allow multiple piezo transducers, e.g. positioned side by side, to be positioned against the bottom housing 250, so that the multiple transducers can be driven in unison for stronger haptic effects or at different times to provide sensations at particular locations of the touchpad element 238.

One way to provide the drive signal is to provide an initial oscillating carrier signal at or near the natural frequency  $f_n$ , modulate the carrier signal with an effect envelope, if applicable (e.g. shape the amplitude to a desired configuration to provide a desired frequency or effect), and drive an amplifier with the modulated signal, which in turn drives the piezo transducer. A sine wave carrier signal, as opposed to square wave or other types, used in such an embodiment tends to produce quieter haptic effects in the described embodiment of Fig. 8b, which is often more desirable.

In an alternate embodiment, the piezoelectric transducer and spacer can be reversed in orientation so that the spacer 240 contacts the bottom housing 250, the diaphragm 231 rests on the spacer 240, the ceramic element 242 is positioned above the diaphragm, and the ceramic



element directly impacts the touchpad element 238 or a pad coupled to the touchpad member when it is oscillated by the driving signal. In yet other embodiments, the ceramic element can be directly coupled to the touchpad element, but in general less strong and effective haptic effects are the result.

### Surface Translation Embodiments

These embodiments translate a surface that is in contact with the user to provide haptic feedback to the user. The user feels the translating surface in shear with his or her skin, creating an immediate sensation. This type of haptic feedback is based on either surface motion in-plane without interactions with fixed surfaces or relative motion between adjacent surfaces that are in contact with the users finger or hand. Both translation of a surface in contact with or adjacent to the touchpad module surface (Figs. 9-12), as well as displacement of the touchpad surface itself (Figs. 13-14) are embodiments described below, as well as actuators that may be used for either application (Figs. 15-17). Moving-surface inventions described in U.S. Patent No. 5,184,868 can also be applied.

Small (< 1 mm) displacements between adjacent surfaces provide good signal transmission into finger tissue. Enhanced surfaces may have a physical surface texture (bumps, roughness, etc.) and can be shaped to engage the user for any position or orientation. In some embodiments, small lateral translations (displacements under the finger tip between .25mm to 0.5mm) can be more effective than remote inertial vibrations or even out-of-plane (z-axis) vibrations right under the touchpad, e.g., inertial coupling can have a more remote and disconnected feeling in some embodiments.

### Separate Surface Translation

Displacing a separate surface member positioned on top of a touchpad module is very effective at providing well-correlated feedback. The feedback feels sufficiently synchronized that clear surfaces may be translated above visual displays, as in PDAs or touch screens. Translation of other surfaces to the side or otherwise adjacent to the touchpad can also be performed in other embodiments.

FIGURE 9 is a perspective view of a first separate surface translation embodiment 250 in which a separate thin surface that is in sliding contact with the touchpad module is moved laterally under the finger. A translating surface member ("surface") 252 is positioned on top of and covering the fixed touchpad 254. Extension members 256a and 256b which are coupled to the translating surface 252 can be extended approximately perpendicularly in the x- and y- directions away from the touchpad 254. An actuator 258a and 258b can be coupled to each

associated extension member 256a and 256b, respectively. In the described embodiment, the actuators 258 are linear actuators outputting a linear force on the associated extension member 256, thereby moving the translating surface in the direction of the output force. For example, the actuators can be “E” core actuators. The two pole magnet 259 is not shown on the actuator 258b to reveal the coil 260 under the ferromagnetic piece 382.

The sliding surface 252 can be any of a variety of stiff or substantially stiff materials; for example, Kapton (polyamid) flexible printed circuit board material can be used. The extension members 256 can incorporate a stiffener section to prevent buckling. The sliding surface 252 can be a textured surface that provides a friction force to engage the user skin tissue in contact with the surface. A region on the top of the moving surface 252 can include the texture having sufficient surface roughness to provide purchase on the skin without feeling rough to touch. On the underside of the moving surface, a low friction coating can be included to promote sliding between surface 252 and touchpad 254. This underside component can be very thin, for example, less than 0.010 inches (.25 mm) thick.

The user points to and contacts the moving surface 252 just as if it were the touchpad 254 itself. The surface 252 is made thin enough so that the touchpad 254 can detect all the contact of the user to the surface 252 as if the user were touching the location of the touchpad directly underneath the location touched on the surface 252.

In some embodiments, the actuators can be located relatively far from the moving surface (e.g., >10cm) and in these cases the stiffer extension members 256 may need to transmit tension and compression with as little friction or out-of-plane movement as possible. Fiber laminations of glass or carbon can perform this function, for example.

In some moving magnet actuator embodiments, thin rare earth magnetic pieces can be laminated to the moving surface 252 to act as the moving magnets. A high level of integration can be achieved, for example, if the moving magnet pieces are on the order of < 1 mm in thickness and the “E” core and coil are located below the distal segments of the extensions 256, e.g., mounted directly to the touchpad PCB itself. The coil wires can be soldered directly to the touchpad PCB.

FIGURE 10 is a top plan view of another translating surface embodiment 270 in which a separate moving tactile surface is positioned above, and in sliding contact with, the touchpad. This surface is translated relative to the touchpad by a high bandwidth actuator through a high fidelity mechanical linkage.

In this embodiment, a translating surface 272 is positioned over a touchpad 274, similar to the embodiment of Fig. 9. An extension member 276 can protrude in a direction (x-direction

here) towards a rotary actuator 278, which in this example is grounded to the laptop housing 280. The actuator 278 can be a DC rotary motor having a rotatable shaft 282 that is coupled to a coupling linkage 284 that is in turn coupled to the extension member 276. For example, a portion of the linkage from the actuator assembly 150 described above can be used. When the actuator 278 rotates the shaft 282 in either direction, the linkage converts the rotation to surface 272 translation in a corresponding direction (left or right). For example, a displacement of about +/- 1 mm can be achieved. The user feels the surface translation when moving a finger over the surface 272. Motor rotation can result in very clean high fidelity translation in the X axis. A DC motor design may work in a laptop given spare volume out at the sides or locations in the front of the enclosure or housing. A similar extension, linkage and motor can be provided in the y-direction to move the surface 272 in that direction. The input of the user is detected on the touchpad through the moving tactile surface.

The thin surface can be trimmed to fit inside the touchpad area with a small border all around. A rectangular extension can be cut out of a larger lamination to provide a fairly rigid strip that is driven with an actuator. This strip should be wide enough to allow the actuator to push on it in operation without the strip buckling.

As in the embodiment of Fig. 9, a smooth surface can be provided on the underside of surface 272 that contacts the touchpad to provide a smooth low-friction sliding interface with the touchpad plastic covering that the user's finger normally touches. The top side of the moving surface 272 can be made frictional to allow a good user grip, e.g. a texture like fine sandpaper. This can provide an excellent contact surface because it provides some mechanical bonding with the finger surface, but is not rough enough to feel rough to touch. Other embodiments can use a variety of types of friction surfaces. Other embodiments may also use flatter actuators, such as moving magnet actuators or voice coil actuators.

Two strips 286 of plastic or other material can be attached to the bezel surrounding the touchpad (i.e. the rim of the housing opening for the touchpad) and covering the edges of the surface 272 in order to constrain the moving surface 272 and keep it flat against and parallel to the touchpad 274.

The embodiments of Figs. 9 and 10 can provide compelling haptic sensations. Adding a surface above the touchpad does not substantially interfere with the sensor operation of the touchpad. A user can concurrently point and receive haptic feedback through motion of this surface relative to the fixed touchpad. It is simple for the user to provide input to the laptop or other electronic device when touching and moving a finger over the translation surface above the touchpad. In some embodiments, the moving surface can be held above, not in close contact with, the touchpad and so some compression by the user may be required to take the free play out and come into proximity with the sensor array.

When moving a cursor over displayed scroll bars and around on the desktop GUI displayed by the laptop, the user feels distinct, high fidelity effects that are well correlated spatially with the cursor. The character of the correlation may be different depending on whether the user moves a finger or object in the x- or the y-axis. The actuator in the shown embodiment 270 moves the surface 272 in the x-axis. Consequently, moving the cursor up and down over icons, the user may feel pops or similar tactile effects as unidirectional if the user does not concentrate on or observe that the motion of the surface 272 is perpendicular to the cursor motion.

Motion of the user's finger in the translated direction -- the x-axis in the example of Fig. 10 -- tends to be more compelling. For example, as the user drags a finger in the x-direction to move a cursor from one displayed radio button to the next, the surface 272 may lead the user into the next button and can feel like a detent even though very small motions of the surface are being generated. A surface translation force opposing the direction of motion can be effective, e.g. if the user is moving left onto an icon, a translation force directed to the right feels crisp and natural. If haptic feedback is allowed in only one axis, the y-axis may be a better choice in some embodiments because there may be more vertically-oriented content on a GUI desktop and in applications.

A short, distinct pulse can provide excellent transitions when moving the cursor from one object to another, such as between graphical buttons. Vibrations can be conveyed to the user in surface translation embodiments by oscillating the actuator driving the surface, e.g. with a sine or other periodic wave, and thereby oscillating the translating surface in opposite directions.

The user also may naturally tend to take his or her finger off of the touchpad between motions that control the cursor, and an inherent spring centering of the motor and linkage can return the moving surface 252 or 272 to a neutral (origin) position, ready for the next interaction. The controlled cursor is not moved while the feedback apparatus has moved back to the neutral origin position, since only the surface above the touchpad moves and does not provide input to the computer through the touchpad like a user's finger.

Motion in a particular direction allows the surface translation embodiments to act in some embodiments as a relative pointing device with local pseudo-kinesthetic feedback. Tactile feedback is still the primary type of haptic feedback provided in such an embodiment, but the small displacements of the surface can be dramatically perceived as directed spring forces acting in such a way that they feel like detent "slopes" that force the user's finger in a direction, even though they are just pops.

The overall stiffness of the actuator can affect results. If the user presses too strongly on the moving surface, then the user may move the surface while dragging / pointing the finger and this can run the actuator out of its spring center. A preferred embodiment has a forceful but stiff actuator, one that the user can barely back-drive by pressing strongly.

Having particular amount of travel or compliance on the moving surface, e.g. about 2 mm, is desirable in some embodiments. There is a strong spring centering from the motor and linkage, and moving the cursor between two objects, such as buttons in a GUI, can be very realistic because the user may perceive true kinesthetic force feedback until finger pressure is decreased and the finger is moved quickly across the screen in a relative mode. The haptic effects which are output are simple tactile pops, and no actual kinesthetic springs are providing force in the X or Y directions. However, the user senses that his or her finger is being pulled into an adjacent object, e.g. the next button.

It should be noted that kinesthetic force feedback is possible in a different embodiment. For example, if the user keeps his or her finger in one place on the moving surface, and the moving surface has a large enough displacement, forces can be output in the degrees of freedom of motion of the moving surface, providing kinesthetic force feedback. The sensor of the touchpad can be used as the sensor indicating the position of the finger/moving surface for computation of the force, such as a spring force having a magnitude dependent on the distance that is moved from an origin of the spring. Thus, such an embodiment would be a dual mode haptic system, including both tactile and kinesthetic modes.

Some embodiments of the moving surface may allow sliding by the user, while others may be very stiff with little sliding. In many embodiments, if the maximum permitted movement of the surface is enough to allow traversal between two adjacent graphical targets, then the kinesthetic mode can be effective and user may not notice that he or she is moving the surface. Some embodiments can provide translation and forces in two axes (X and Y), allowing this kinesthetic directed feedback (real springs) in all directions of the touchpad.

Haptic effects may not feel the same if the user is not moving his or her finger or object on the touchpad. There is often content and value in the correspondence of touchpad motion with the haptic effect (e.g., a detent pop effect). For example, it is effective when the user finger is moving and receiving the pop effect when the finger translates the moving surface to the transition point between the icons or buttons.

Many of the advantages described above for separate translating surfaces are also applicable to translating the touchpad surface, described in detail below.

FIGURE 11 is a perspective view of another embodiment 290 of a separate translating surface and moving coil actuator. In this embodiment, a frame 292 is positioned over the touchpad 294 of the device. Frame 292 includes a thin surface portion 296 which is located directly above the touchpad 294 and is thin enough to allow the user's contact on the portion 296 to be detected by the touchpad 294 underneath. Frame 292 also includes an integrated voice coil 298 which is part of a voice coil actuator 300. The coil 298 can be wire traces that are molded into the frame 292, which can be a PCB. The other parts of the actuator 300 include a stationary two-pole magnet 302 positioned over the coil 298 and grounded to the laptop housing, and a backing plate 304 made of steel, positioned on the other side of frame 292 and grounded to the housing, and used for a flux return path. The steel subassembly can be attached to the touchpad PCB itself, for example.

Thus, the magnetic fields of the magnet 302 and the current flowing through coil 298 interact to cause a linear force on the frame 298, which causes the frame and portion 296 to move as indicated by arrow 306. This provides haptic sensations to the user similarly to the separate translating surface embodiments described above. The housing can surround the entire frame except for an opening surrounding the portion 296 of the frame 292. In some embodiments, wires from the coil 298 can be connected to the touchpad PCB using a separate flex circuit finger that branches off of the moving frame 292.

FIGURE 12 is a perspective view of another embodiment 310 of a separate translating surface. In this embodiment, a surface surrounding the touchpad is translated in x- and/or y-direction with respect to the touchpad surface. Thumb surface 312 is positioned at the bottom side of the touchpad 314 and is rigidly coupled to a link member 295. Link member 316 is coupled to a flexible link 318, which is coupled to the rotatable shaft of an actuator 320 that is grounded to the laptop housing. When the actuator 320 rotates the shaft, the flexible link 318 moves the link member 316 linearly as indicated by arrow 322, which moves the thumb surface 312 linearly along the x-axis. The thumb surface 312 is shown in sliding contact with a standard button (not shown) which is directly underneath the surface 312.

The user can rest his or her thumb, palm, or finger on the thumb surface 312 while operating the touchpad in order to feel the haptic sensations. To press the button located underneath the thumb surface 312, the user simply presses down on the surface 312. Overall, the sensations tend to be similar to the sensations for the other translating surfaces described above. In other embodiments, the link member 316 can be much longer to allow desired placement of the actuator 320 in the housing of the laptop or other device.

One disadvantage is that there is no feedback to the user unless the user has a thumb, finger, or palm on the thumb surface area. The user may have to reach for other buttons to type and then lose the haptic experience. A larger surface 312 or palm pad extension can be used in

embodiments in which it may be difficult to keep the user's thumb on the surface 312 while using the same hand to point with the touchpad.

### Touch Device Translation

These embodiments translate the touchpad (or touchscreen) surface itself rather than moving a separate surface. The user feels the translating touchpad moving laterally, in shear with his or her skin, creating an immediate sensation. The touchpad can be moved relative to a fixed surround, such as a laptop housing.

FIGURE 13 is a perspective view of one embodiment 330 providing a translating touchpad surface. Touchpad 332 is moved relative to a housing 334, such as a laptop or PDA housing, by an actuator 336. In the described embodiment, the actuator 336 is a rotary actuator, such as a DC motor, having a rotating shaft 338 that is coupled to a linkage 340. The linkage 340 is coupled to a bracket 342 at its other end, where the bracket 342 is coupled to the underside of the touchpad 332 module. The linkage includes joints and/or flexibility/compliance to allow the rotational motion of the shaft 338 to be converted to linear force on the bracket 342, thereby causing the touchpad 332 to move laterally as shown by arrows 344. For example, the linkage can be made of polypropylene, similar to the linkages of the actuator assembly of Fig. 5. The laptop housing can serve as a constraining structure for the moving touchpad module.

For example, a standard DC motor can be used for actuator 336 and a polypropylene linkage assembly for linkage 340. In one embodiment, the haptic feedback components can reside where optional components for the laptop are normally placed, such as an optional disc drive.

In other embodiments, the actuator 338 can be located remotely from the touchpad 332, e.g., wherever space is available in the housing as opposed to directly underneath the touchpad as illustrated in Fig. 13. Linkages can be used to locate the actuator(s) remotely from the touchpad, as shown in Fig. 14 below.

Translating the entire touchpad in one or two axes may be one good overall haptics approach. Very small displacements ( $0.2\text{mm} < x < 0.5\text{mm}$ ) of the touchpad are desired to provide useful haptics. The power consumption for this embodiment when evaluated within a practical magnitude range can be less than the consumption of currently available inertial mice interface devices, which can receive all needed power over the interface to the host computer, such as USB.

Some advantages are apparent in this type of embodiment. Feedback experience is direct, well correlated with pointing, and precise. Implementation can be flexible and

unobtrusive, and addition of haptic components does not alter how the touchpad is used. The translating surface has a small displacement requirement compared with inertial approaches – this can lead to reduced power consumption and manufacturing benefits. In some embodiments, the motion of the touchpad can be oriented at an angle in the x-y plane. Some disadvantages may include use of a DC motor, which are relatively large, a flexible linkage may need a lot of clearance and may cause friction, and power consumption may be relatively high.

FIGURE 14 illustrates a perspective view of another embodiment 350 of a moving touchpad, in which the touchpad may be moved in both X and Y directions. The touchpad 351 is directly coupled to a first linkage member 351, which is coupled to a rotating shaft of an actuator 353 by a flexible member 354, such as polypropylene. Actuator 353 is grounded to the laptop housing. When actuator 353 rotates its shaft, the flexible member 354 converts the rotary motion to linear motion and translates the linkage member 352 in the x-direction, which in turn translates the touchpad as indicated by arrow 355. At the distal end of the first linkage member 354, a second linkage member 356 is coupled, e.g. by a flexible coupling.

A second actuator 358, grounded to the laptop housing, is coupled to the other end of the second linkage member 356 by a flexible member 357, where the axis of rotation of the rotating shaft of the actuator 358 is substantially the same as the axis of rotation of the actuator 353. The rotary force output by the rotating shaft of the actuator 358 is converted to a linear force by the flexible member 357. This linear force causes the second linkage member 356 to move linearly along its length, which in turn causes the first linkage member 352 to pivot approximately about its end near actuator 353 along the y-axis and cause the touchpad 351 to move approximately along the y-axis. The actuators 353 and 358 can be, for example, DC motors or any other type of actuator, e.g. linear actuators can also be used, as described below in Figs. 15-17. The linkage members can be made of any suitable material, e.g. carbon fiber. Preferably, very little energy is absorbed by the grounded structure or by unwanted deformations in the linkage assembly.

Thus, the mechanism decouples the x- and y-motions; by activating actuator 353, x-axis motion is provided, and by activating actuator 358, y-axis motion is provided; both x- and y-axis motion can be provided by activating both motors simultaneously. Both actuators can be driven either together (common mode) or differentially (differential mode) to achieve pure X or Y movement without binding the linkage parts. Furthermore, any combination of drive current will produce a resultant force along any arbitrary axis with the same fidelity and lack of binding.

One embodiment may use firmware for rapid evaluation and output of X and Y forces, e.g. software running on a local controller such as a microprocessor, or running off the host CPU. In some embodiments, such firmware may be too complex, so that alternatively, a



mechanism with an electronic way of switching between the two principle feedback axes can be used. In one embodiment, the two DC motors can be connected in a series circuit with switch that reverses the current through one of the two motors.

In the embodiment of Fig. 14, the user may feel the difference between x- and y-directional forces when moving a finger or object on the touchpad in the x-direction. There is haptic value in having the correlation or alignment of tactile feedback with finger/cursor motion; in some cases, alignment can boost the haptic signal-to-noise ratio. For example, moving the cursor right to left over icons or buttons may feel better and more like real buttons to the user when the feedback is directed horizontally along the x-axis. Less power may be required overall if the feedback is aligned with the cursor direction instead of being omnidirectional or misaligned. In some cases, a weaker aligned haptic effect may be more meaningful than a stronger misaligned effect.

The touchpad surface with enhanced texture moves relative to a fixed surrounding surface with enhanced texture. The enhanced texture is more rough, corrugated, or otherwise textured, allowing a stronger user contact.

In some other embodiments, the touchpad surface can be comprised of interdigitated surface features that move relative to each other in x- and/or y- directions. For example, two halves of a touchpad can be driven by actuator(s) to move relative to each other.

In other embodiments, other actuators can be used to move the touchpad, touchscreen, or other touch device in the z-direction. For example, piezo-electric actuators, voice coil actuators, or moving magnet actuators can be directly coupled to the touchpad or touchscreen to provide direct motion of the touch surface. Also, the touchpad surface can be comprised of a fixed tactile surface and a reference surface, where the reference surface can be displaced along the z-axis with respect to the fixed tactile surface.

FIGURES 15a and 15b are perspective views of the top side and bottom side, respectively, of a different embodiment of a novel “flat-E” actuator 360 for use in translating a touchpad. FIGURE 15c is a side view of the actuator 360. Actuator 360 is designed to be very flat and thus may be more appropriate to function within a flat assembly that can be inherently part of the touchpad, touchscreen, or other similar input device. “E-core” actuator topology provides an excellent actuator using minimal magnet material and delivers good force and bandwidth. One disadvantage of the moving magnet actuator is the large depth required (“E” core ferromagnetic piece width can be traded for height to some extent, perhaps reducing the overall depth of the actuator).

Actuator 360 presents a inventive embodiment of an “E” core that can be used to translate the touchpad (or alternatively to translate a separate surface, as in the embodiments of Figs. 9-14). A folded over, flat 3-D embodiment, shown in Figs. 15a-15b, that may behave substantially like a 2-D case, but with more leakage and non uniform flux at the poles.

Actuator 360 includes a ferromagnetic piece 362 shaped as an “E”, which can be made of a metal such as a ferrous metal or carbon steel plate, and can be a single piece of metal or a lamination. A coil 364 of wire is wound about the central pole of the “E” of the ferromagnetic piece 362. A floating plastic cage 368 can be positioned on the ferromagnetic piece 362 and can include two or more rollers 370 positioned in apertures in the cage and oriented so that the rollers roll about axes parallel to the axis passing through the coil 364 about which the coil is wound. The cage can be plastic and is floating, i.e. unattached to other components, to allow the rollers to roll. A two-pole magnet 366 is positioned above the poles of the ferromagnetic piece 362 and cage 368 so that there is an air gap between magnet and ferromagnetic piece. The magnet 366 is coupled to the underside (in the orientation of the figures; other orientations are possible) of a backing steel piece 372 which is positioned on top of and contacting the rollers 370. The rollers thus set the nominal magnetic gap between the magnet and the ferromagnetic piece 362. The backing steel piece 372 can be rigidly coupled to the touchpad 373, as shown in FIGURE 15d, so that the touchpad, steel piece 372, and magnet 366 can translate relative to the ferromagnetic piece 362. For example, the magnet may in some embodiments be a two pole bonded neodymium wafer, and the steel parts may be stamped from single sheets about 1 mm thick. Additional rollers or foam can be used to support the end of the ferromagnetic piece opposite the magnet 366. The magnet, cage, and backing piece are located to the side of the “E” poles rather than at the front edge as in other E-core type actuators; this allows the actuator of the present invention to be made very flat for laptop and other portable device applications.

In operation, an electrical current is flowed through the coil 364, which causes magnetic flux to flow through the ferromagnetic piece in the direction of arrows 374. In reaction, the steel plate 372 moves in a direction along the axis indicated by arrow 376 (the direction is dependent on the direction of the current in the coil). The rollers 370 rotate to allow the steel plate 372 and magnet 366 to translate relative to the ferromagnetic piece 362. The floating cage 368 keeps the rollers from moving in undesired directions as they rotate. Also, the magnetic attractive normal forces which occur between ferromagnetic piece 362 and magnet 366 are reacted with the rollers 370. Other Flat-E related embodiments can include flexure and knife-edge suspensions to react (allow motion from) magnetic normal forces.

The flat E actuator embodiments described herein can be used to translate the touchpad (or touchscreen) or a separate surface member above or to the side of the touchpad. For

example, two flat E actuators can be used in a configuration similar to that of Fig. 9 to drive the touchpad or surface member in two axes, x and y.

The actuator 360 can be made very thin in comparison with other actuators, e.g. the assembly can be made approximately 3 or 4mm thick, less than half as thick as other "E" core actuators. The magnetics design can be iterated for optimal performance. Linearity and detent forces can be traded for thickness.

Advantages include a planar, thin geometry, which is suitable for laptops, PDA, and other portable devices. The moving magnet approach does not require a large air gap so it may be more attractive for laptop haptic feedback. An "E" core prototype was 10mm X 20mm X 8mm and is smaller than most DC motors with equivalent force and power consumption. Furthermore, it is a direct drive configuration, so no transmission is required between actuator and touchpad. Efficient, low cost, and easy to manufacture components allow the actuator to be produced cheaply. The actuator is simple to integrate with existing touchpad PCB's and modules. One disadvantage is that magnetic attractive normal forces exist, which may necessitate a suspension. Rollers and/or flexure and knife edge suspensions can be used in some embodiments to react magnetic normal forces.

The actuator 360 generally provides good bandwidth. Larger (e.g., > 1mm) displacements can be achieved. Those embodiments employing foam to support the opposite end of the ferromagnetic piece have a return spring having a low spring constant, mostly from the foam suspension operated in shear mode. Audible noise may also be reduced by using the foam and/or rollers. While the haptic performance is good, the displacement of the surface is small enough so that when the user is moving a finger over the touchpad to move the cursor over the desktop, the surface displacement does not noticeably affect the cursor motion.

FIGURES 16a and 16b are perspective views of the top side and bottom sides of another embodiment 380 of the "flat-E" actuator of Figs. 15a-15c. A ferromagnetic piece 382 (or a lamination, in other embodiments) includes an approximate "E" structure and has a coil 384 wound around the E center pole 385. A two-pole magnet 386 is positioned across the E center pole 385 such that a gap is provided between ferromagnetic piece 382 and magnet, similarly to the embodiment 360. A metal plate 388 (e.g., steel) is coupled to magnet 386 and is provided parallel to the ferromagnetic piece and magnet. A cage 390 can be provided as the middle layer, where rollers 389 (shown as dashed lines) can be positioned within apertures in the cage 390 and allow the plate 388 to slide laterally with respect to the ferromagnetic piece and magnet. A touchpad or touchscreen (not shown) can be rigidly coupled to the top of plate 388, with piece 382 grounded. In alternate embodiments, the touchpad or touch screen can be coupled to the piece 382 with plate 388 grounded.

Embodiment 380 also includes a flexible suspension, which can be coupled to the middle layer plastic cage 390 and can include two linkages 392 that are thus effectively coupled between the steel plate 388 and the ferromagnetic piece 382. The linkages 392 contact the steel plate 388 at ends 394 and are coupled to the cage layer 390 at ends 396 (or molded with the cage layer as a single plastic piece). Each linkage includes a thinner portion 398 and a thicker portion 400.

In operation, a current is flowed through coil 384 and the magnetic forces resulting from the current and magnet 386 cause the plate 388 (and the touchpad) to move as indicated by axis 402. The suspension including linkages 392 prevents the plate 388 from skewing due to magnetic normal forces and any other forces. Each linkage 392 flexes to accommodate the motion of the plate 388, where the thinner members 398 flex first, and the thicker members 400 flex if the limits of flex are reached for members 398. The thinner-thicker structure allows spring centering to operate until the thicker (stiffer) beams are engaged, which provide a softer feeling stop to motion. The final limit to motion is caused by either of the stops 404 hitting the inner edge of the plate 388.

The flexible suspension described above effectively allows lateral desired motion of the plate and touchpad, but prevent motion in any other direction. This creates a much more stable motion of the plate 388 and does not allow the plate 388 to drift in its position over time. Furthermore, the suspension provides a desirable spring centering force on the plate 388 and touchpad, allowing the touchpad to move to the center of its range of motion when the user stops touching and forcing the touchpad.

FIGURES 17a-17g are views illustrating another flat-E actuator touchpad embodiment 420 that miniaturizes this type of actuator and provides fabricated surface mount devices that take advantage of existing lead frame and over molding manufacturing technologies. Such small scale devices can be wave soldered onto the touchpad module and can work in parallel to provide suitable stroke and force for touchpad translation (or for z-axis forces in alternate embodiments).

Figures 17a-17c illustrate a top view of a PCB 422 which includes multiple Flat-E actuators 424. An actuator 424 can be positioned at each corner of the PCB 422 as shown. More or less actuators than shown can alternatively be placed in other configurations. The use of multiple actuators 422 can provide greater magnitude forces and allow each actuator 422 to have a lower force output and cost. In one embodiment, the PCB 422 is a separate PCB that is grounded to the housing of the laptop. The touchpad (e.g., including its own PCB different from PCB 422) is then coupled to the moving portions of the actuators, e.g., to the pads 426 shown in Fig. 17a. In another embodiment, the PCB 422 is the touchpad, and the moving portions of the actuators are coupled to a grounded surface in the laptop, such as the housing.

In such an embodiment, the actuators 424 can be hidden from the user by a lip of housing that extends around the perimeter of the touchpad, leaving the center area of the PCB 422 exposed to the user.

Fig. 17d is a side elevational view of one end of a PCB 422, separate from the touchpad, that includes the flat-E actuators 424. The touchpad/PCB member 428 is coupled to the moving portions 430 of the actuators 424.

Fig. 17e is a perspective view illustrating one embodiment of the underside of the PCB 422 shown in Fig. 17a, where the flat-E actuators 424 have been surface mounted to the underside of the PCB 422. This can be done as "hand-placed" components, or preferably using automatic surface mount technology placement equipment. The "E" ferromagnetic piece 432 can be grounded to the PCB 422 so that the magnet and steel backing plate of the actuator move.

Figs. 17f and 17g are perspective views illustrating top and bottom views, respectively, of the flat-E actuator 424 which has 3 poles and can operate similarly to the flat-E actuators described above. Ferromagnetic piece 432 is shaped like an "E" and has a coil 434 wrapped about the center pole. Flexures 436 allow the magnet 438 and steel backing plate 440 to move relative to the ferromagnetic piece 432 and coil 434. The touchpad (not shown) can be coupled to the steel backing piece 440 and the E-laminate piece 432/coil 434 can be grounded, as in the embodiments of Figs. 17a-17e. Alternatively, the backing piece 440 and magnet 438 can be grounded and the touchpad can be coupled to a moving ferromagnetic piece 432.

A flat-E actuator as described above can be used to translate touchpad modules or palm surfaces directly. In the described embodiments, the total thickness of the flat-E actuator can be about 3 mm or less. Flat-E magnetic assemblies that can be integrated into the an existing touchpad product line represent a preferred embodiment in terms of size, manufacturability and economy of scale.

In other embodiments, other moving magnet actuator designs, and other voice coil actuator designs, such as described in U.S. Patent Nos. 6,166,723 and 6,100,874, can be used.

In other embodiments, other types of input surfaces or display screens can be similarly translated using any of the actuators described herein. For example, a clear surface such as the input sensing device(s) covering a display screen of a personal digital assistant (PDA) or a touch screen on a monitor or CRT, can be similarly translated in the X and/or Y directions (parallel to the screen surface) to provide haptic feedback. One application for such clear screen translation is ATM machines, where the user typically inputs information on a touch screen. Haptic feedback can make such input more accessible and easy for people with below-

average vision. Haptic feedback can indicate when the user's finger is over a graphically-displayed button, or can identify particular displayed buttons with different haptic sensations. This can be useful in many ATM applications since there is not a cursor that is moved; haptic feedback can thus be useful to indicate to the user that a button has been pressed, e.g. a small vibration is output when a button is activated. Haptic feedback may also assist users in noisy environments, such as in areas with high vehicular traffic, where sound may not be easily heard by the user.

The embodiments described herein can also provide haptic feedback in an embodiment where the user is using a stylus or other object to input data on the touchpad, touch screen, or input area. The haptic sensations can be transmitted to the user from the touchpad (or other moving surface) and through the stylus or other object.

#### Other Features

A human factor issue related to haptic feedback in some embodiments may include force overload protection. Ideally, for non-inertial feedback actuators and transmission designs such as the translating surfaces and differential surfaces, it is desired for the actuator to produce large forces with fidelity regardless of the load on the actuator or the position within the actuator travel. Put another way, the finger or hand of the user should not move the actuator against a limit or reach an end of travel condition where half of a vibration cycle is attenuated. For this reason, it is desirable to design actuator and transmission mechanisms that are inherently decoupled from the user loading. An example of this would be an E-core actuator with very high spring centering provided by a stiff suspension, as in the embodiment of Fig. 16a-16b. A forceful actuator can overcome this spring force easily, and the forces of a finger dragging on a touchpad surface are a small percentage of full scale actuator output. A weaker actuator may require a more compliant suspension, and this would allow the user interaction to interfere with oscillations and create non-linear output.

Another human-factor-related issue with haptic feedback in some embodiments can be audibility. The use of palm rest surfaces and inertial actuator assemblies, for example, causes sound that is the unavoidable side effect of a haptic sounding board. Loaded surfaces, such as when the user is touching the housing or touchpad, radiate sound poorly, and still transmit forces quite well. Thus, in some embodiments, a load measuring device can be used to determine when the user's hands are present on moving surfaces to allow forces to be output only when such hands are present.

To save costs when providing haptic functionality to a laptop touchpad or other similar input device, the existing sound electronics within the laptop, PDA, or other device can be utilized in some embodiments. For example, the existing sound analog output (e.g. digital-to-

analog converter) and the sound power amplifiers can drive the actuator used for haptic feedback for the touchpad or other laptop component as described above, without having to add an additional microprocessor and/or additional power electronics. A notch filter or other pickoff from the sound signal can be used to provide the haptic feedback signal. For example, haptic effect control signals can be provided in the inaudible range of the sound spectrum and filtered so that these control signals can be provided to the haptic actuator, while the remainder of the signal in the audible range is routed to the audio speakers of the laptop. Or, dedicated signals that are outside the audible range and not included with audio signals can be filtered or routed to control the haptic feedback actuator(s).

Furthermore, existing software on many laptops tracks the battery power for the laptop to indicate power level, warn the user, or shutoff the laptop to conserve battery power. This tracking software can be tapped into for haptic feedback applications. For example, if battery power gets below a certain level, the haptic feedback software routines can scale down or even turn off the output forces to the user. This can be accomplished by dropping the magnitude of the forces, or by reducing the types or number of graphical objects in the GUI that have haptic effects associated with them. This can also be accomplished by shortening the duration of haptic effects, e.g. effects that are normally 50 ms can be reduced to 40 ms, etc. Also, a combination of such methods can be used. Finally, some laptop computers have different settings, such as high power, medium power, and low power, which a user can select according to his or her needs, e.g. lower power setting allows the batteries to last longer. The haptic feedback control can link into the setting and be governed by this setting as well. For example, if the user selects low power mode, the haptic feedback controller can adapt as described above to reduce power requirements of the haptic effects.

FIGURE 18 is a top elevational view of a touchpad 450 of the present invention. Touchpad 450 can in some embodiments be used simply as a positioning device, where the entire area of the touchpad provides cursor control. In other embodiments, different regions of the pad can be designated for different functions. In some of these region embodiments, each region can be provided with an actuator located under the region or otherwise physically associated with the region, while other region embodiments may use a single actuator that imparts forces on the entire touchpad 450. In the embodiment shown, a central cursor control region 452 can be used to position a cursor or viewpoint displayed by the laptop computer or other device.

The cursor control region of a touchpad can cause forces to be output on the touchpad based on interactions of the controlled cursor with the graphical environment and/or events in that environment. The user moves a finger or other object within region 452, for example, to correspondingly move the cursor 20. Forces are preferably associated with the interactions of

the cursor with displayed graphical objects. For example, a jolt or “pulse” sensation can be output, which is a single impulse of force that quickly rises to the desired magnitude and then is turned off or quickly decays back to zero or small magnitude. The touchpad 450 can be jolted in one direction or as an oscillation in the z-axis or other axis inertially in the inertial haptic feedback embodiments, or the touchpad can be translated in one direction or oscillated one or more times to provide the pulse. A vibration sensation can also be output, which is a time-varying force that is typically periodic. The vibration can cause the touchpad 450 or portions thereof to oscillate back and forth multiple times, and can be output by a host or local microprocessor to simulate a particular effect that is occurring in a host application.

Another type of force sensation that can be output on the touchpad is a texture force. This type of force is similar to a pulse force, but depends on the position of the user’s finger on the area of the touchpad and/or on the location of the cursor in a graphical environment. Thus, texture bumps can be output depending on whether the cursor has moved over a location of a bump in a graphical environment. This type of force is spatially-dependent, i.e. a force is output depending on the location of the cursor as it moves over a designated textured area; when the cursor is positioned between “bumps” of the texture, no force is output, and when the cursor moves over a bump, a force is output. This can be achieved by the host sending the pulse signals as the cursor is dragged over the grating, or, a separate touchpad processor can be dedicated for haptic feedback with the touchpad, and the texture effect can be achieved using local control (e.g., the host sends a high level command with texture parameters and the sensation is directly controlled by the touchpad processor). In other cases a texture can be performed by presenting a vibration to a user, the vibration being dependent upon the current velocity of the user’s finger (or other object) on the touchpad. When the finger is stationary, the vibration is deactivated; as the finger is moved faster, the frequency and magnitude of the vibration is increased. This sensation can be controlled by the touchpad processor (if present), or the host. Other spatial force sensations can also be output. In addition, any of the described force sensations herein can be output simultaneously or otherwise combined as desired.

Different types of graphical objects can be associated with haptic sensations. Haptic sensations can output on the touchpad based on interaction between a cursor and a window, menu, icon, web page link, etc. For example, a “bump” or pulse can be output on the touchpad to signal the user of the location of the cursor when the cursor is moved over a border of a window. In other related interactions, when a rate control or scrolling function is performed with the touchpad (through use of the cursor), sensations can be output related to the rate control functions. Furthermore, the magnitude of output forces on the touchpad can depend on the event or interaction in the graphical environment, including user-independent events. These force sensations can also be used in games or simulations. These and other haptic sensations are described in U.S. Patent No. 6,211,861. Other control devices or grips that can include a



touchpad of the present invention in its housing include a gamepad, mouse or trackball device for manipulating a cursor or other graphical objects in a computer-generated environment; or a pressure sphere or the like.

Some forms of touchpads and touchscreens allow the amount of pressure the user is exerting on the touchpad to be sensed. This allows a variety of haptic sensations to be determined based at least in part on the sensed pressure. For example, a periodic vibration can be output having a frequency that depends on the sensed pressure. Or, the gain (magnitude) of output haptic sensations can be adjusted based on the sensed pressure. Those users that always tend to use the touchpad with more pressure can be allowed to select an automatic magnitude increase that would be in effect constantly.

Other embodiments of touchpads and touchscreens allow the user to enter “gestures” or shortcuts by tracing a symbol on the cursor control region or other region, which is recognized as a command or data by a processor. Haptic sensations can be associated with or dependent on particular gestures. For example, a confirmation of modes can be conveyed haptically with a particular haptic sensation when a mode confirmation gesture is recognized. Characters recognized from gestures also may each have a particular haptic sensation associated with them. In most touchpad embodiments, a user can select a graphical object or menu item by “tapping” the touchpad. Some touchpads may recognize a “tap-and-a-half” or double tap, which is the user doing a tap and then again touching the pad and maintaining the finger or object on the pad while moving the finger. For example, such a gesture can provide a “drag” mode in which objects may be moved with the cursor. When the user is in such a drag mode, a vibration or other haptic sensation can be output to indicate to the user that this mode is active.

As stated above, the touchpad 450 can also be provided with different control regions that provide separate input from the main cursor control region 452. In some embodiments, the different regions can be physically marked with lines, borders, or textures on the surface of the touchpad 450 (and/or sounds from the computer 10) so that the user can visually, audibly, and/or or tactilely tell which region he or she is contacting on the touchpad.

For example, scroll or rate control regions 454a and 454b can be used to provide input to perform a rate control task, such as scrolling documents, adjusting a value (such as audio volume, speaker balance, monitor display brightness, etc.), or panning/tilting the view in a game or simulation. Region 454a can be used by placing a finger (or other object) within the region, where the upper portion of the region will increase the value, scroll up, etc., and the lower portion of the region will decrease the value, scroll down, etc. In embodiments that can read the amount of pressure placed on the touchpad, the amount of pressure can directly control the rate of adjustment; e.g., a greater pressure will cause a document to scroll faster. The region

454b can similarly be used for horizontal (left/right) scrolling or rate control adjustment of a different value, view, etc.

Particular haptic effects can be associated with the control regions 454a and 454b. For example, when using the rate control region 454a or 454b, a vibration of a particular frequency can be output on the touchpad. In those embodiments having multiple actuators, an actuator placed directly under the region 454a or 454b can be activated to provide a more localized tactile sensation for the “active” (currently used) region. As a portion of a region 454 is pressed for rate control, pulses can be output on the touchpad (or region of the touchpad) to indicate when a page has scroll by, a particular value has passed, etc. A vibration can also be continually output while the user contacts the region 454a or 454b.

Other regions 456 can also be positioned on the touchpad 450. For example, each of regions 456 can be a small rectangular area, like a button, which the user can point to in order to initiate a function associated with the pointed-to region. The regions 456 can initiate such computer functions as running a program, opening or closing a window, going “forward” or “back” in a queue of web pages in a web browser, powering the computer 10 or initiating a “sleep” mode, checking mail, firing a gun in a game, cutting or pasting data from a buffer, saving a file to a storage device, selecting a font, etc. The regions 456 can duplicate functions and buttons provided in an application program or provide new, different functions.

Similarly to regions 454, the regions 456 can each be associated with haptic sensations; for example, a region 456 can provide a pulse sensation when it has been selected by the user, providing instant feedback that the function has been selected. For example, a haptic sensation such as a pulse can be output when the user “taps” a finger or object on a region 456, 452, or 454 to make a selection. Similar to physical analog buttons that provide a range of output based on how far the button is pushed, one or more regions 456 can be an analog-like button by providing a proportional, stepped, or analog output based on the pressure the user is exerting on the touchpad.

Furthermore, the same types of regions can be associated with similar-feeling haptic sensations. For example, each word-processor related region 456 can, when pointed to, cause a pulse of a particular strength, while each game-related region 456 can provide a pulse of different strength or a vibration. Furthermore, when the user moves the pointing object from one region 454 or 456 to another, a haptic sensation (such as a pulse) can be output on the touchpad 450 to signify that a region border has been crossed. For example, a high frequency vibration which quickly decays to zero magnitude can be output when the pointing object enters a designated region. This can be valuable since it provides an indication of the borders to the regions 454 and 456 which the user would not otherwise know. This also allows region reconfiguration of size and/or location and allows the user to quickly learn the new layout

haptically. Regions can also be associated with “enclosures” which define areas in a graphical environment and the different haptic sensations which are output when the cursor enters, exits, and is moved within the enclosure and the particular borders having such haptic associations.

In addition, the regions are preferably programmable in size and shape as well as in the function with which they are associated. Thus, the functions for regions 456 can change based on an active application program in the graphical environment and/or based on user preferences input to and/or stored on the computer 10. Preferably, the size and location of each of the regions can be adjusted by the user or by an application program, and any or all of the regions can be completely removed if desired. Furthermore, the user is preferably able to assign particular haptic sensations to particular areas or types of areas based on types of functions associated with those areas, as desired. Different haptic sensations can be designed in a tool such as Immersion Studio™ available from Immersion Corp. of San Jose, CA.

It should be noted that the regions 454 and 456 need not be physical regions of the touchpad 450. That is, the entire touchpad surface need merely provide coordinates of user contact to the processor of the computer and software on the computer can designate where different regions are located. The computer can interpret the coordinates and, based on the location of the user contact, can interpret the touchpad input signal as a cursor control signal or a different type of signal, such as rate control, button function, etc. (e.g. a driver program can provide this interpreting function if desired). A touchpad microprocessor, if present, may alternatively interpret the function associated with the user contact location and report appropriate signal or data to the host processor (such as position coordinates or a button signal), thus keeping the host processor or software ignorant of the lower level processing. In other embodiments, the touchpad 450 can be physically designed to output different signals to the computer based on different regions physically marked on the touchpad surface that are contacted by the user; e.g. each region can be sensed by a different sensor or sensor array.

Any of those embodiments described herein which provide haptic feedback to the finger or object of the user that contacts the touchpad or touchscreen may be used with the regions of touchpad 450.

While this invention has been described in terms of several preferred embodiments, it is contemplated that alterations, permutations, and equivalents thereof will become apparent to those skilled in the art upon a reading of the specification and study of the drawings. For example, many of the features described in one embodiment can be used interchangeably with other embodiments. Furthermore, certain terminology has been used for the purposes of descriptive clarity, and not to limit the present invention.

*What is claimed is:*

### CLAIMS

1. A haptic feedback touch control for inputting signals to a computer and for outputting forces to a user of the touch control, the touch control comprising:

a touch input device including an approximately planar touch surface operative to provide a position signal based on a location on said touch surface which said user contacts, said position signal representing said location in two dimensions; wherein said computer receives position information derived from said position signal; and

at least one actuator coupled to said touch input device, said actuator outputting a force on said touch input device to laterally move said touch input device approximately parallel to a surface of said touch input device to provide a haptic sensation to said user contacting said touch surface, wherein said actuator outputs said force based on force information output by said computer.

2. A haptic feedback touch control as recited in claim 1 wherein said computer positions a cursor in a graphical environment displayed on a display device based at least in part on said position signal.

3. A haptic feedback touch control as recited in claim 1 wherein said touch input device is a touchpad, said touchpad being separate from a display screen of said computer.

4. A haptic feedback touch control as recited in claim 1 wherein said touch input device is integrated in a housing of said computer.

5. A haptic feedback touch control as recited in claim 1 wherein said user contacts said touch surface with a finger of said user.

6. A haptic feedback touch control as recited in claim 1 wherein said user contacts said touch surface with a physical object held by said user.

7. A haptic feedback touch control as recited in claim 1 wherein said at least one actuator is a first actuator that outputs a first force in a first lateral direction approximately parallel to said surface of said touch input device, and further comprising a second actuator coupled to said touch input device and operative to output a second force on said touch input device in a second lateral direction approximately parallel to said surface and approximately perpendicular to said first lateral direction.

8. A haptic feedback touch control as recited in claim 1 wherein said actuator is a linear actuator that provides an output force in a linear degree of freedom, and wherein said actuator is coupled between said touchpad and a grounded housing.

9. A haptic feedback touch control as recited in claim 8 wherein said actuator is a rotary actuator that provides an output force in a rotary degree of freedom, said output force being converted to said linear force.

10. A haptic feedback touch control as recited in claim 8 wherein said actuator is an E-core actuator.

11. A haptic feedback touch control as recited in claim 10 wherein said actuator includes at least one roller allowing a backing plate of said actuator to slide relative to a magnet of said actuator.

12. A haptic feedback touch control as recited in claim 11 wherein said actuator includes a flexure providing a spring return force between said backing plate and said magnet.

13. A haptic feedback touch control as recited in claim 1 wherein said actuator oscillates said touch input device laterally.

14. A haptic feedback touch control as recited in claim 1 wherein said touch input device includes a plurality of different regions, wherein at least one of said regions provides said position signal and at least one other region provides a signal that is used by said computer to control a different function.

15. A haptic feedback touch control as recited in claim 14 wherein at least one of said regions is associated with a different haptic sensation output on said touch input device than another one of said regions.

16. A haptic feedback touch control as recited in claim 14 wherein a haptic sensation is output when said user moves a contacting object from one of said regions to another one of said regions.

17. A haptic feedback touch control as recited in claim 1 wherein said actuator is a first actuator, and further comprising at least one additional actuator coupled to said touch input device, wherein said actuators are E-core actuators that have been surface mounted to a printed circuit board.

18. A haptic feedback touch control for inputting signals to a computer and for outputting forces to a user of the touch control, the touch control comprising:

a touch input device including an approximately planar touch surface operative to provide a position signal based on a location on said touch surface which said user presses, said position signal representing said location in two dimensions, wherein said computer receives position information derived from said position signal;

a surface member located adjacent to said touch input device, wherein said user can contact said surface when pressing said touch input device; and

at least one actuator coupled to said surface member, said actuator outputting a force on said surface member to provide a haptic sensation to said user contacting said surface member, wherein said actuator outputs said force based on force information output by said computer.

19. A haptic feedback touch control as recited in claim 18 wherein said surface member is translated laterally, approximately in a plane parallel to said planar touch surface.

20. A haptic feedback touch control as recited in claim 19 wherein said surface member is positioned over said touch input device and at least approximately coextensive with said surface of said touch input device, such that said user presses said surface member to press said touch input device.

21. A haptic feedback touch control as recited in claim 20 wherein said actuator is a linear actuator.

22. A haptic feedback touch control as recited in claim 20 wherein said actuator is a rotary actuator, wherein a linkage converts a rotary output force to an approximately linear output force on said translated surface member.

23. A haptic feedback touch control as recited in claim 18 wherein said actuator is a voice coil actuator, wherein a wire coil is physically coupled to said surface member.

24. A haptic feedback touch control as recited in claim 18 wherein said surface member is positioned to a side of said touch input device such that said user touches said touch input device with one finger and touches said surface member with a different finger or palm.

25. A haptic feedback touch control as recited in claim 21 wherein said surface member is positioned over a physical button that is located adjacent to said touch input device.

26. A haptic feedback touch control as recited in claim 18 wherein said force on said surface member is a linear force output approximately perpendicularly to a surface of said surface member.

27. A haptic feedback touch control as recited in claim 26 wherein said linear force is an inertial force output by an actuator assembly that includes said actuator and moves an inertial

mass, wherein said inertial force is transmitted through said surface member to said user contacting said surface member.

28. A haptic feedback touch control as recited in claim 18 wherein said surface member is a palm surface coupled to a housing of said computer and located to the side of said touch input device.

29. A haptic feedback touch control as recited in claim 18 wherein sound electronics of said computer are used to drive said at least one actuator.

30. An actuator providing a linear force output, the actuator comprising:  
a grounded ferromagnetic piece including a center pole located between two side poles;  
a coil wrapped around said center pole;  
a magnet positioned adjacent to said center pole and said side poles, wherein an air gap is provided between said magnet and said ferromagnetic piece; and  
a backing plate coupled to said magnet, wherein said backing plate and said magnet move with respect to said grounded ferromagnetic piece when current is flowed in said coil.

31. An actuator as recited in claim 30 further comprising rollers positioned between said ferromagnetic piece and said backing plate to allow said relative motion between said backing plate and said ferromagnetic piece.

32. An actuator as recited in claim 31 wherein said rollers are constrained by a cage member.

33. An actuator as recited in claim 30 further comprising a flexure coupled between said backing plate and said ferromagnetic piece, said flexure reducing relative motion between said backing plate and said ferromagnetic piece in undesired directions and providing a spring centering force between said backing plate and said ferromagnetic piece.

34. An actuator as recited in claim 30 wherein an entire thickness of said actuator is approximately 4 millimeters or less.

35. A haptic touch device comprising:  
a piezoelectric transducer coupled to a ground, said piezoelectric transducer including a metal diaphragm coupled to a ceramic element;  
a planar sensing element operative to sense a location of a contact from a user on a surface of said planar sensing element and provide information representing said location to a computer controller;  
a spacer provided between said piezoelectric transducer and said planar sensing element, wherein said metal diaphragm contacts said spacer; and

a spring element coupled between said planar sensing element and said ground, said spring element providing a spring restoring force to said planar sensing element.

36. A haptic touch device as recited in claim 35 wherein said piezoelectric transducer is driven with a signal approximately at a natural frequency of said haptic touch device.

37. A haptic touch device as recited in claim 35 wherein said natural frequency can be adjusted by adjusting a spring constant of said spring element or adjusting a mass of said spacer or said planar sensing element.

38. A method for providing haptic feedback to a touch input device that provides input to a computer device, said computer device implementing a graphical environment, the method comprising:

receiving a position signal from said touch input device, said position signal indicating a contact location on a surface of said touch input device where said user is pressing said surface;

determining in which of a plurality of regions said contact location is positioned, wherein said surface of said touch input device is divided into said plurality of regions; and

providing force information to cause at least one actuator to output a force to said user operating said touch input device, said force associated with said user moving an object on or over said surface of said touch input device.

39. A method as recited in claim 38 further comprising implementing a function associated with said region in which said contact location is positioned.

40. A method as recited in claim 39 wherein said function associated with said region includes a rate control function of a value.

41. A method as recited in claim 39 wherein said function associated with said region includes moving a displayed cursor to a screen position based on said position signal.

42. A method as recited in claim 39 wherein said function associated with said region includes a function that can also be initiated by selecting a graphical button displayed by an application program running on said computer device.

43. A method as recited in claim 38 wherein said force is output when said user moves said object over a boundary to said region in which said contact location is positioned from a different region of said touch input device.

44. A method as recited in claim 38 wherein said object moved on or over said surface of said touch input device includes a finger of said user or an object held by said user.



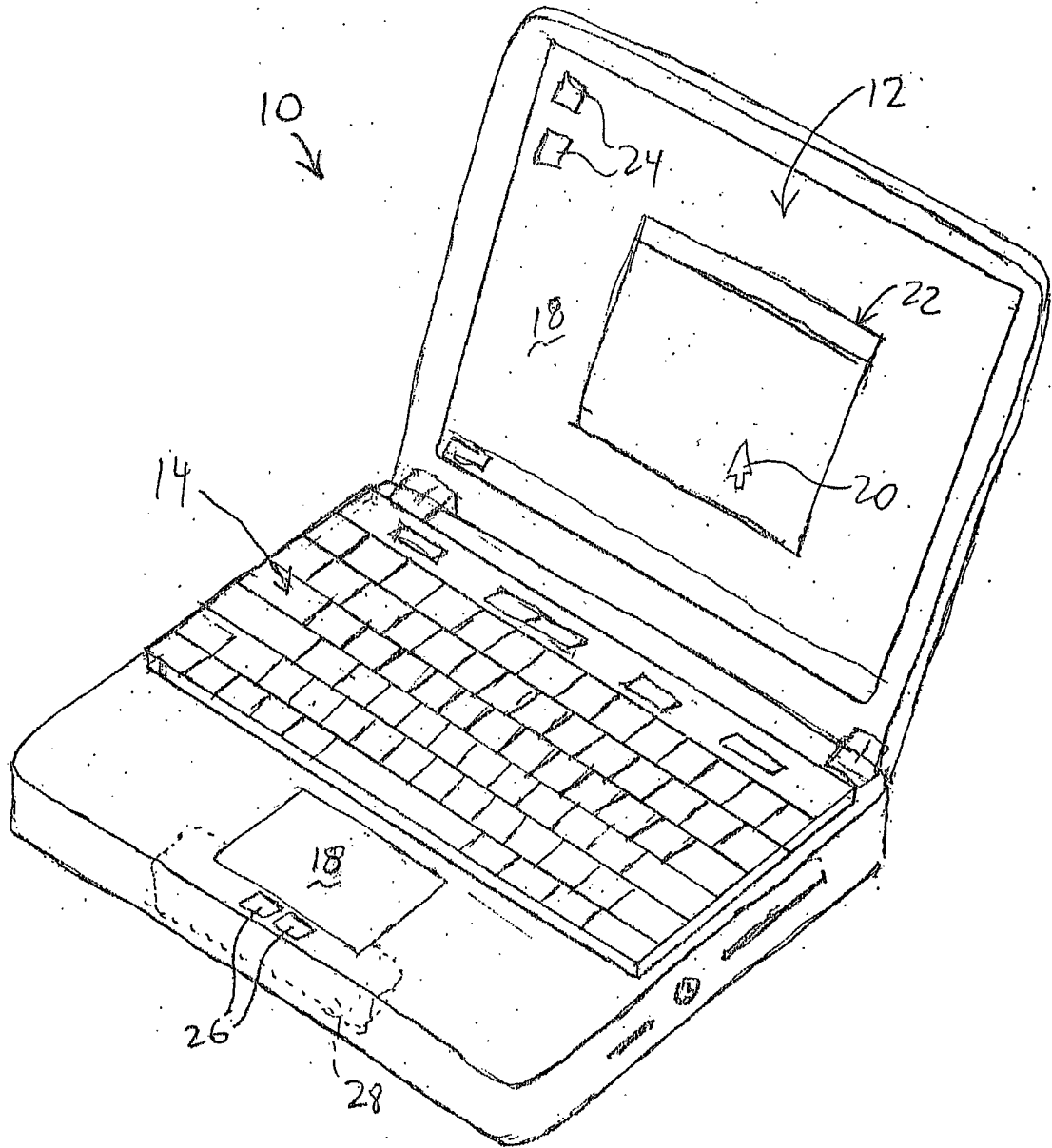
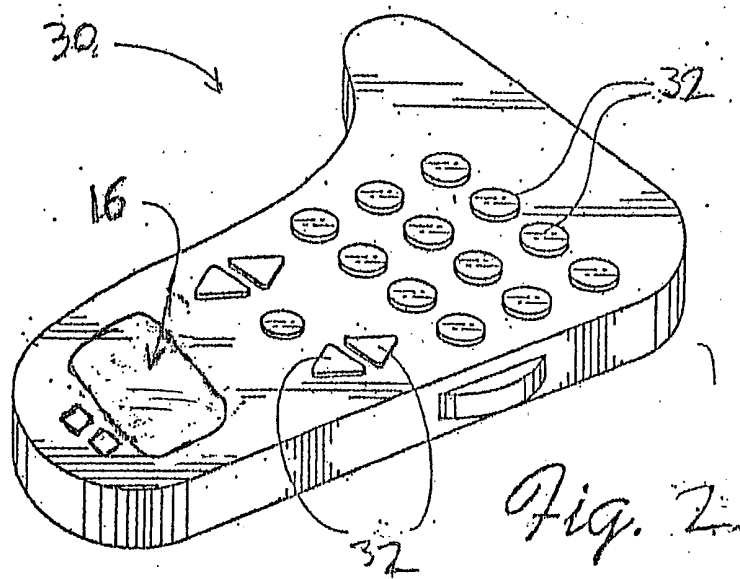

FIG. 1



*Fig. 2*

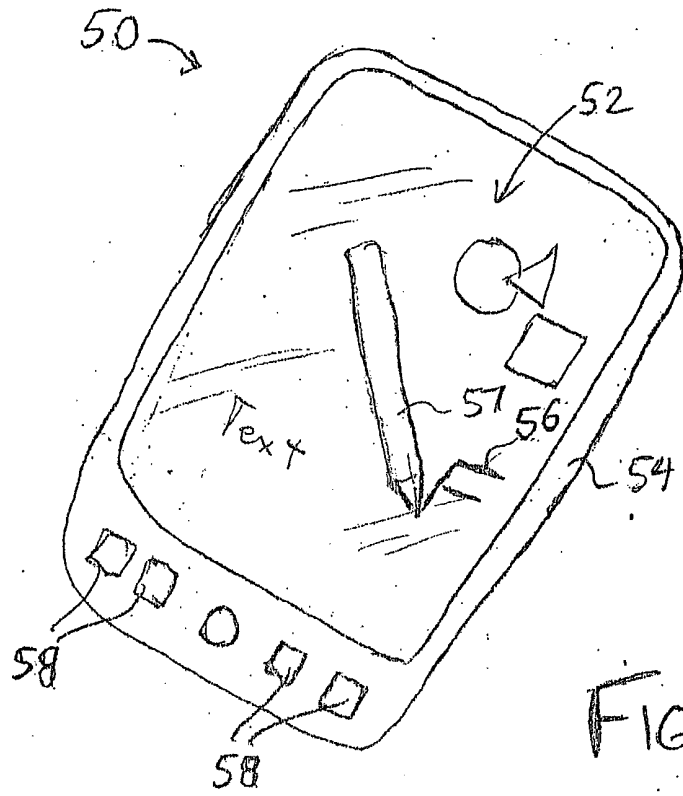

FIG. 3

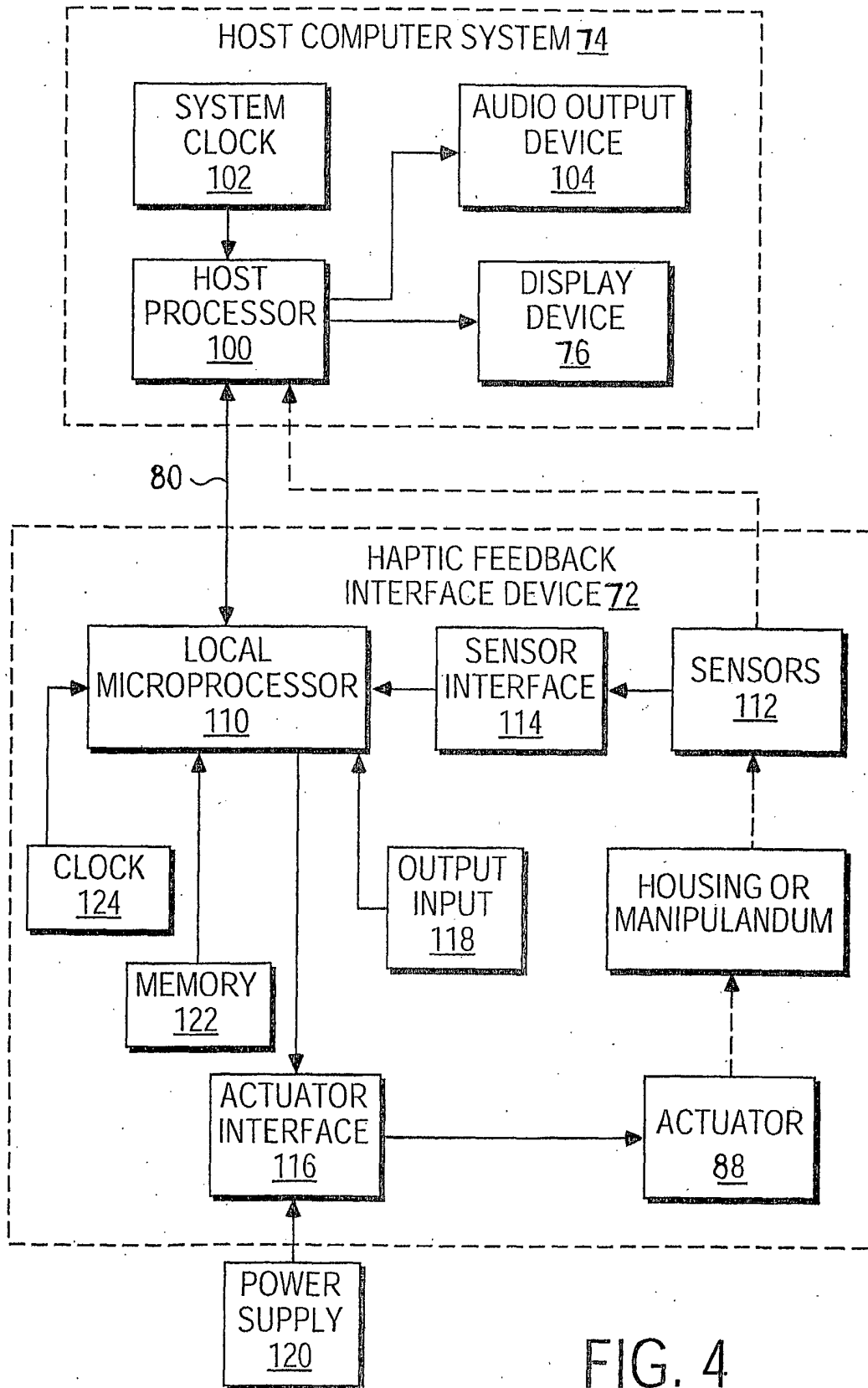

FIG. 4

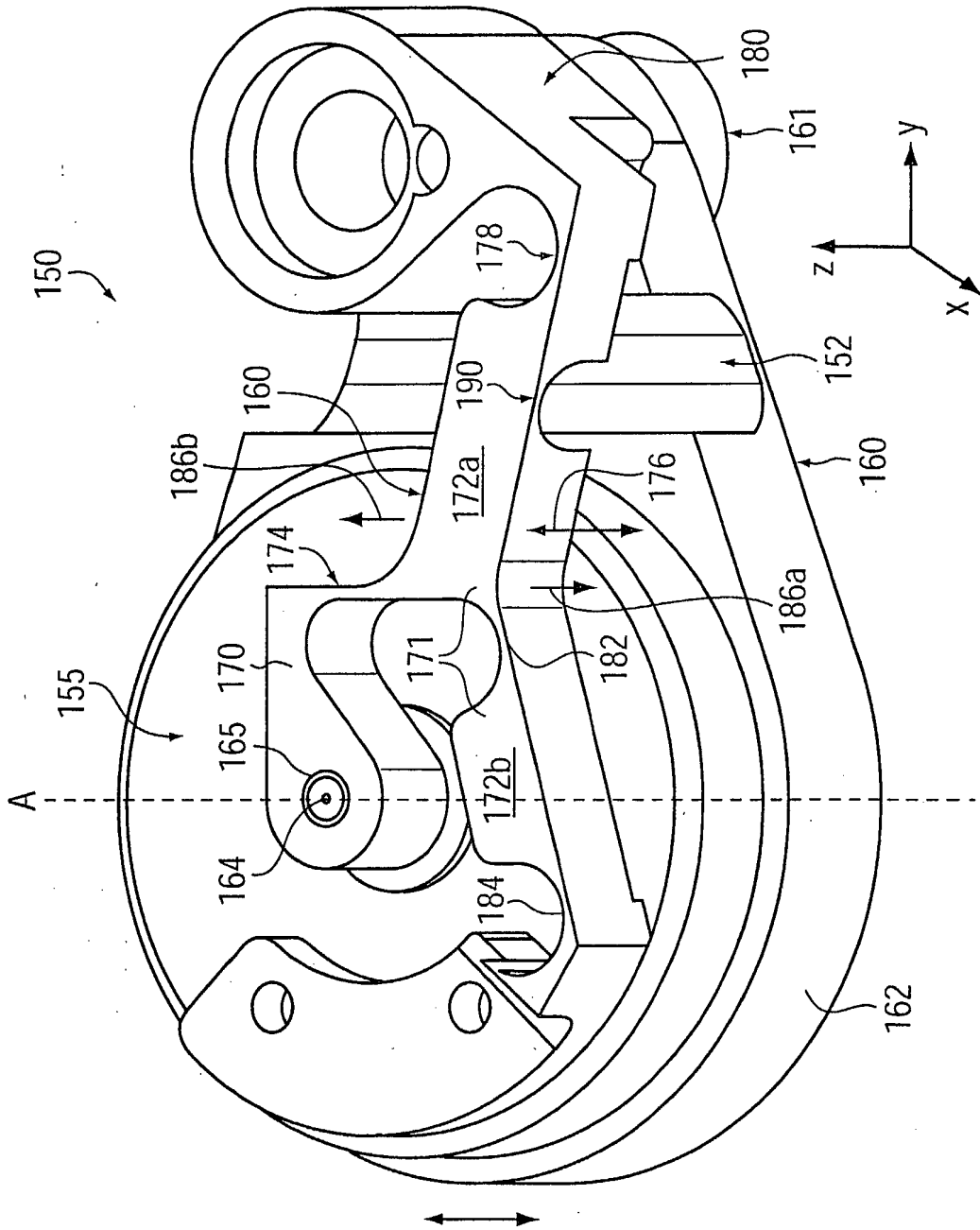

FIG. 5

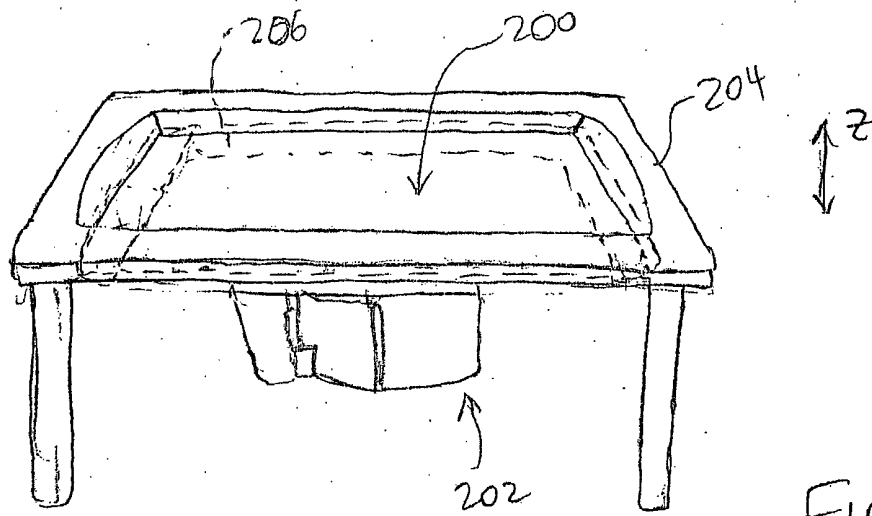

FIG. 6

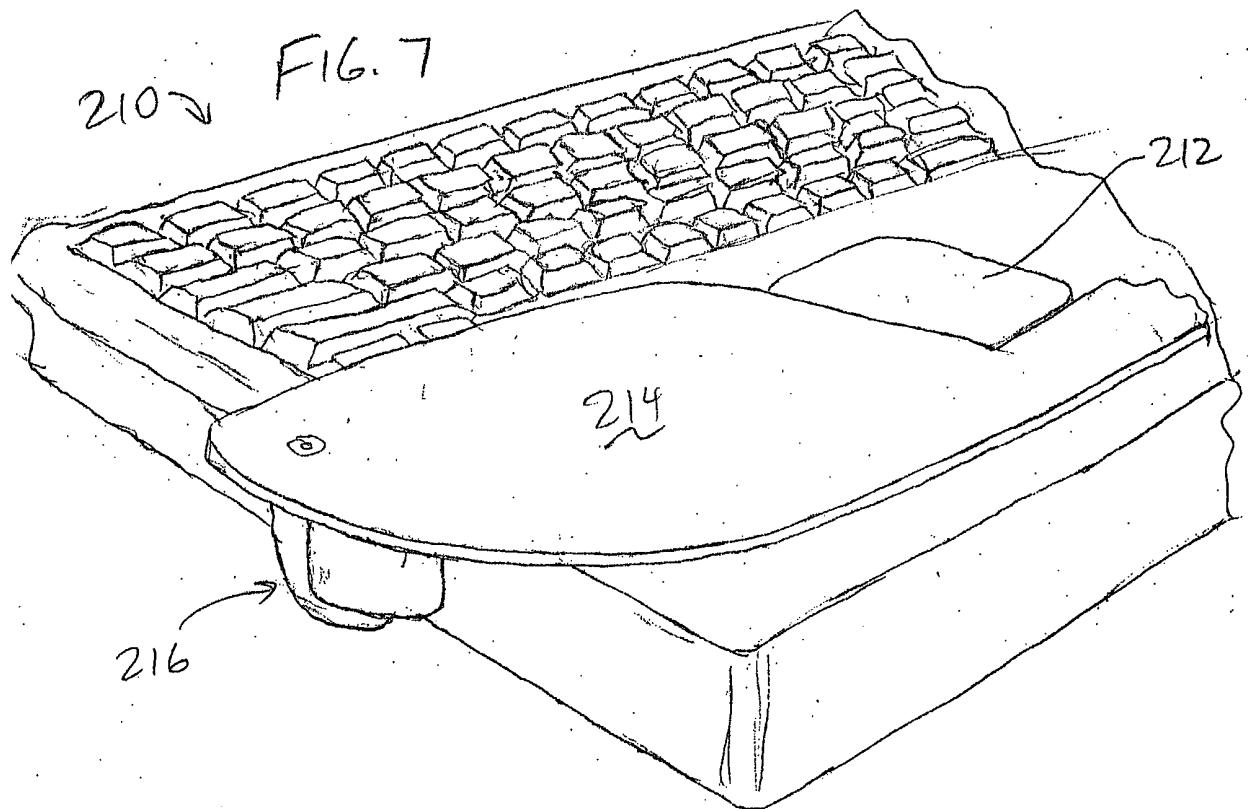

FIG. 7

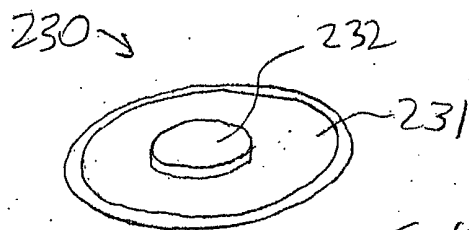

FIG. 8a

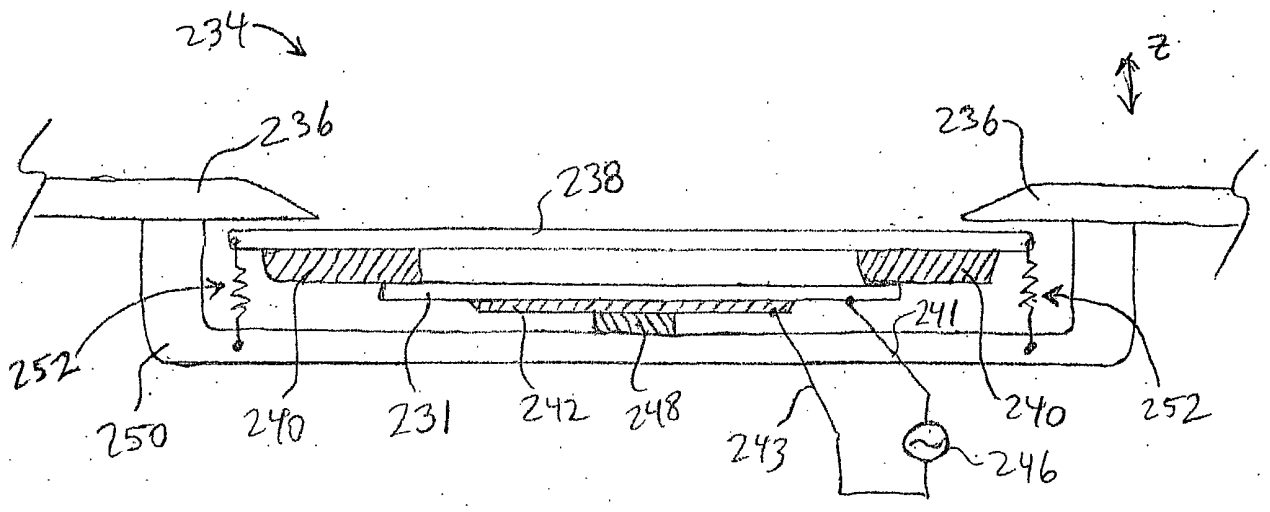
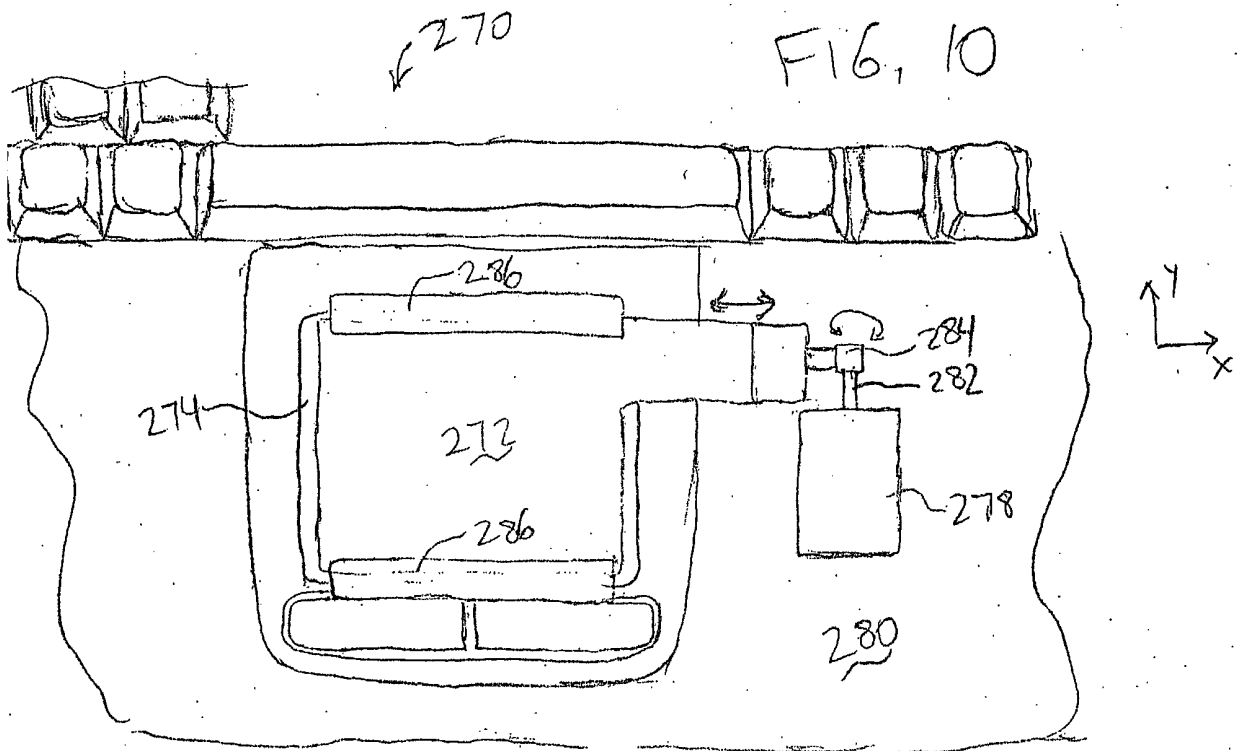
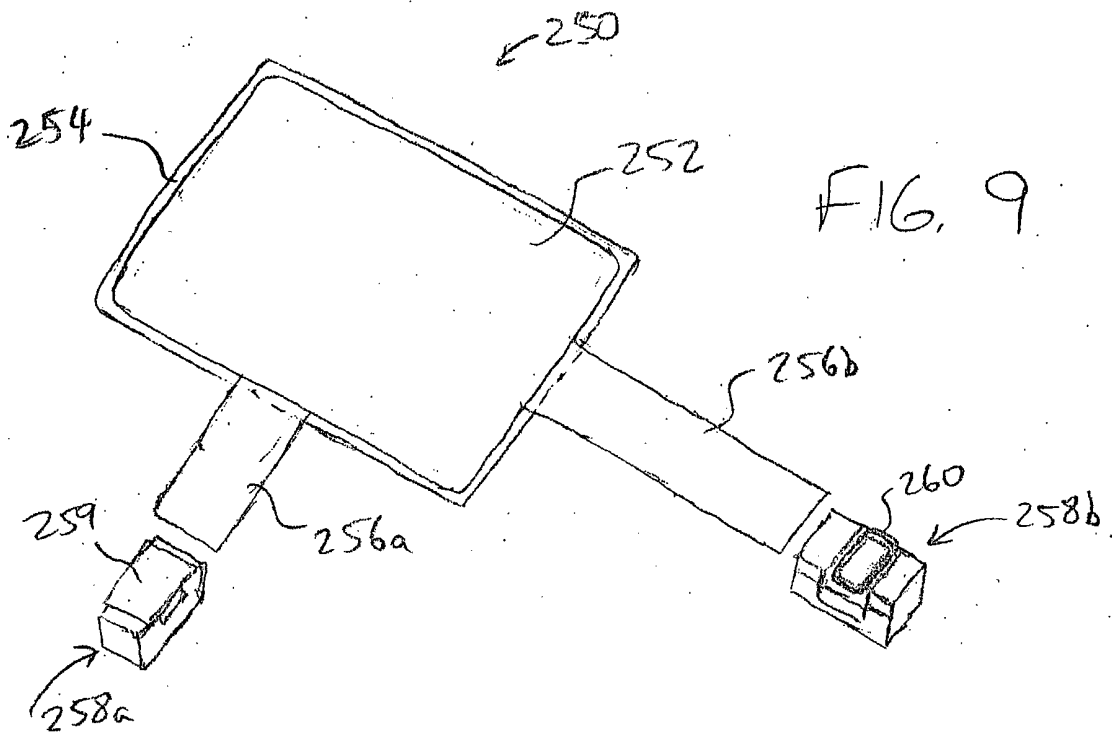
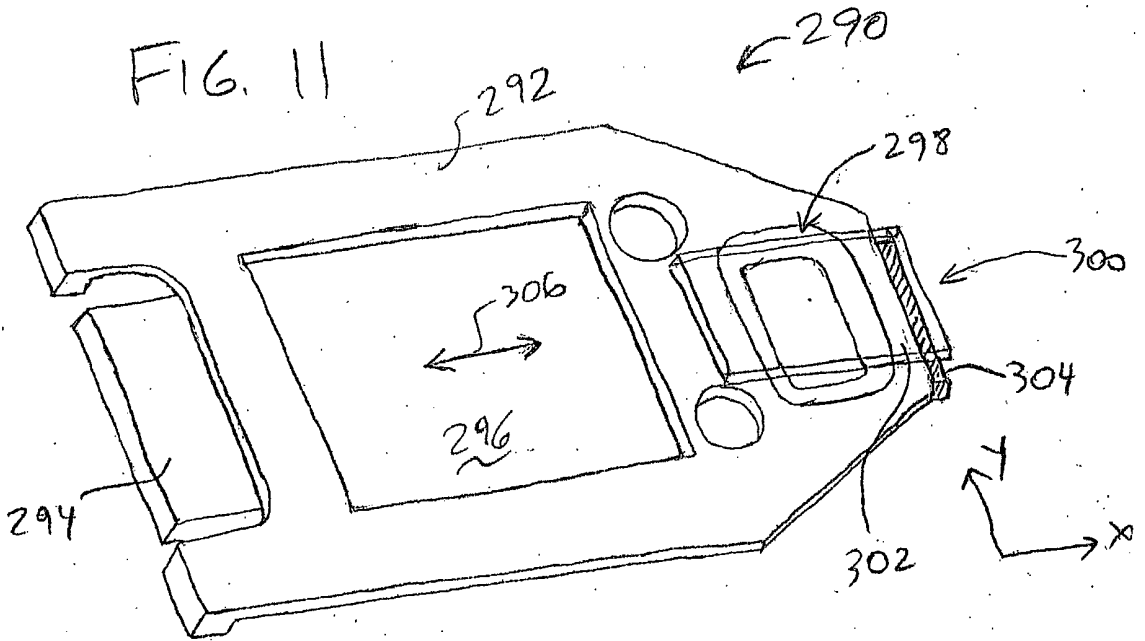

FIG. 8b







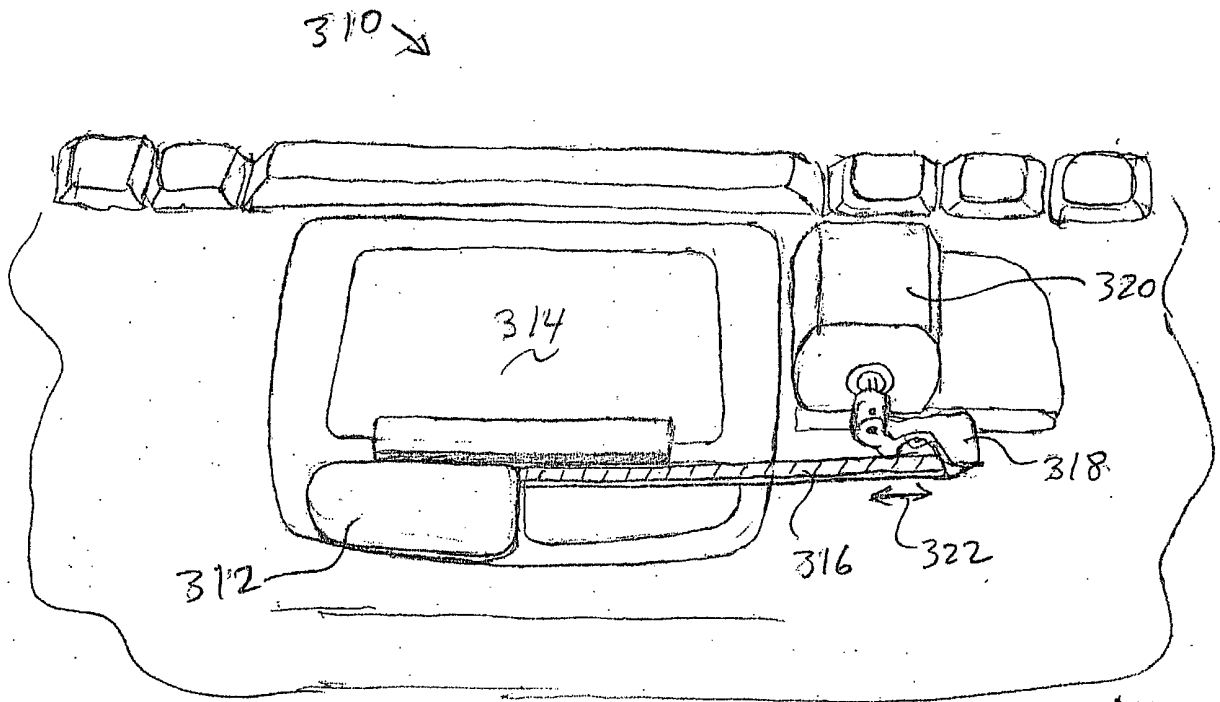
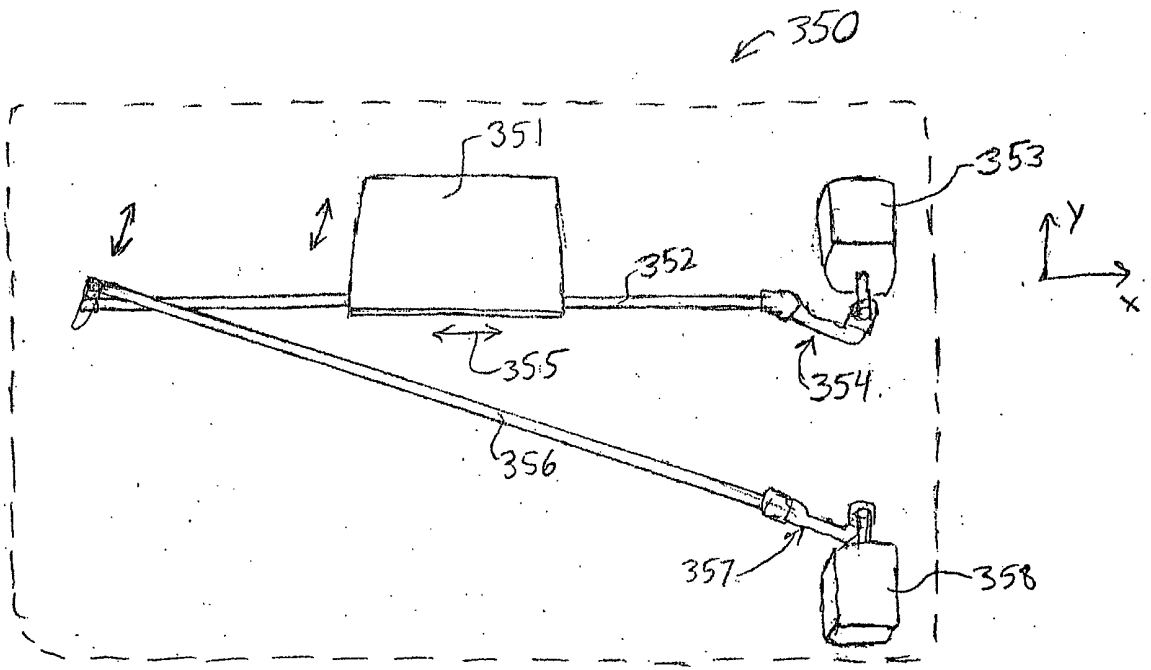
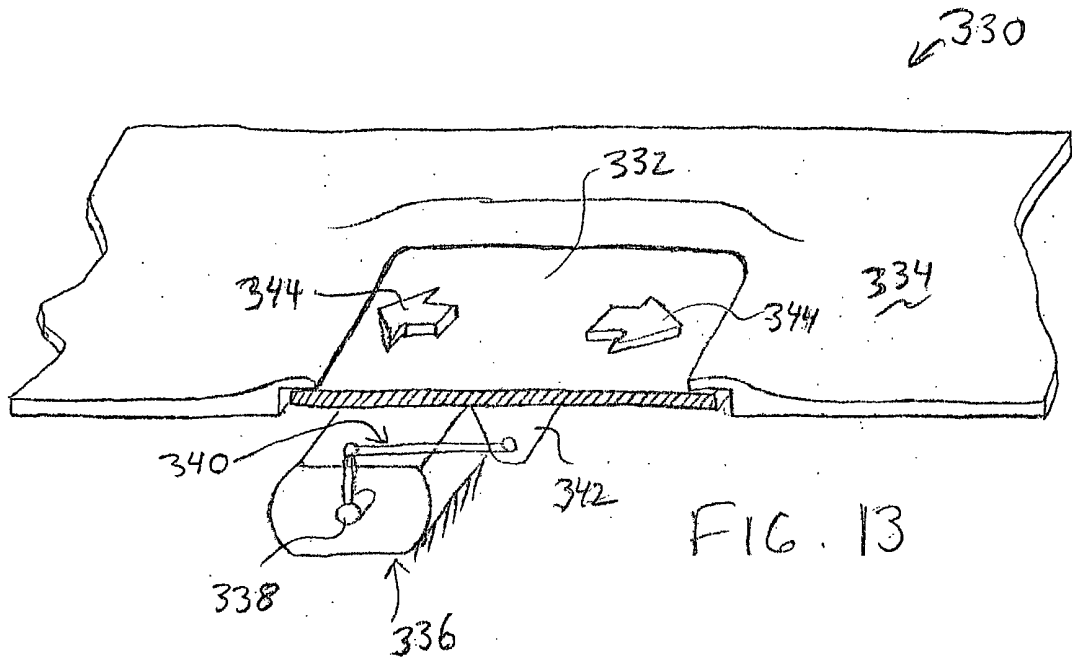
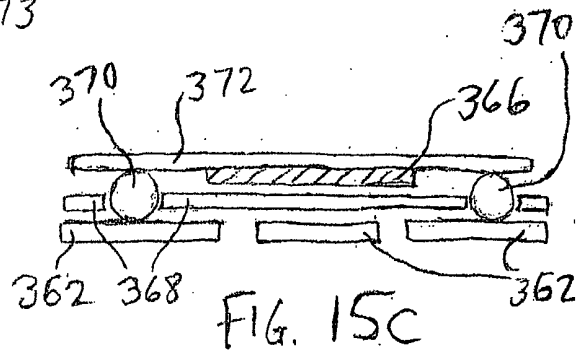
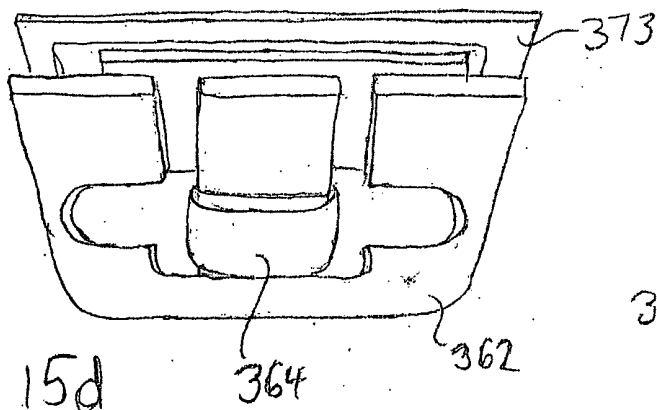
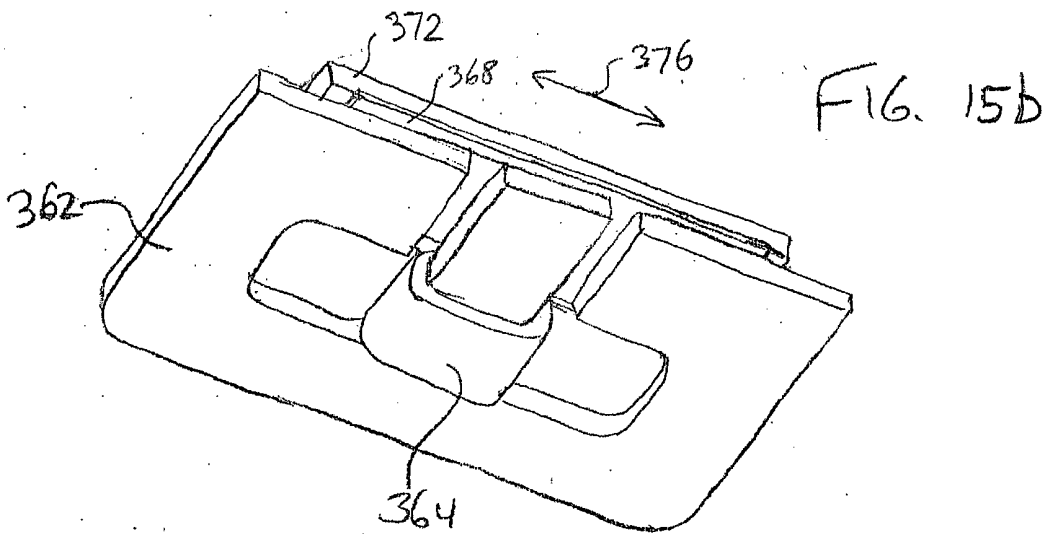
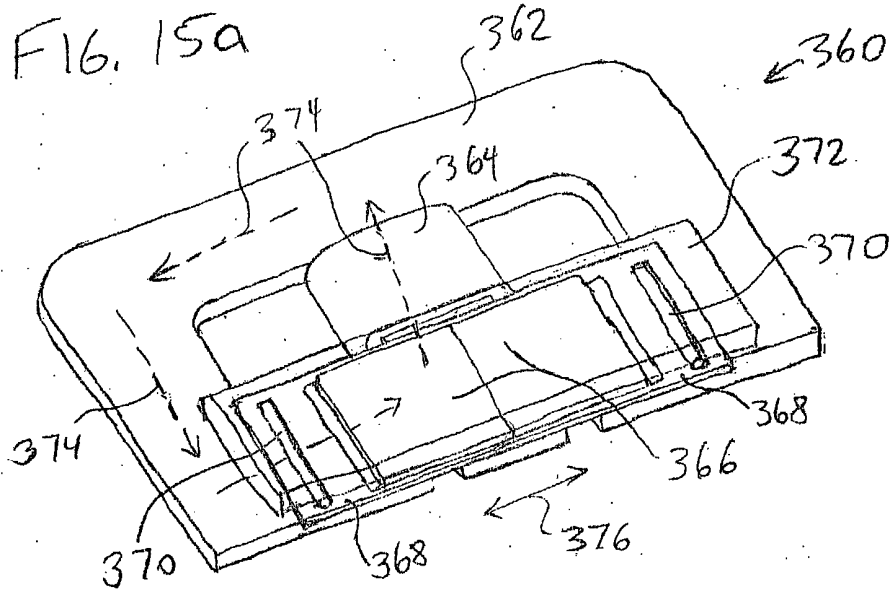

FIG. 12





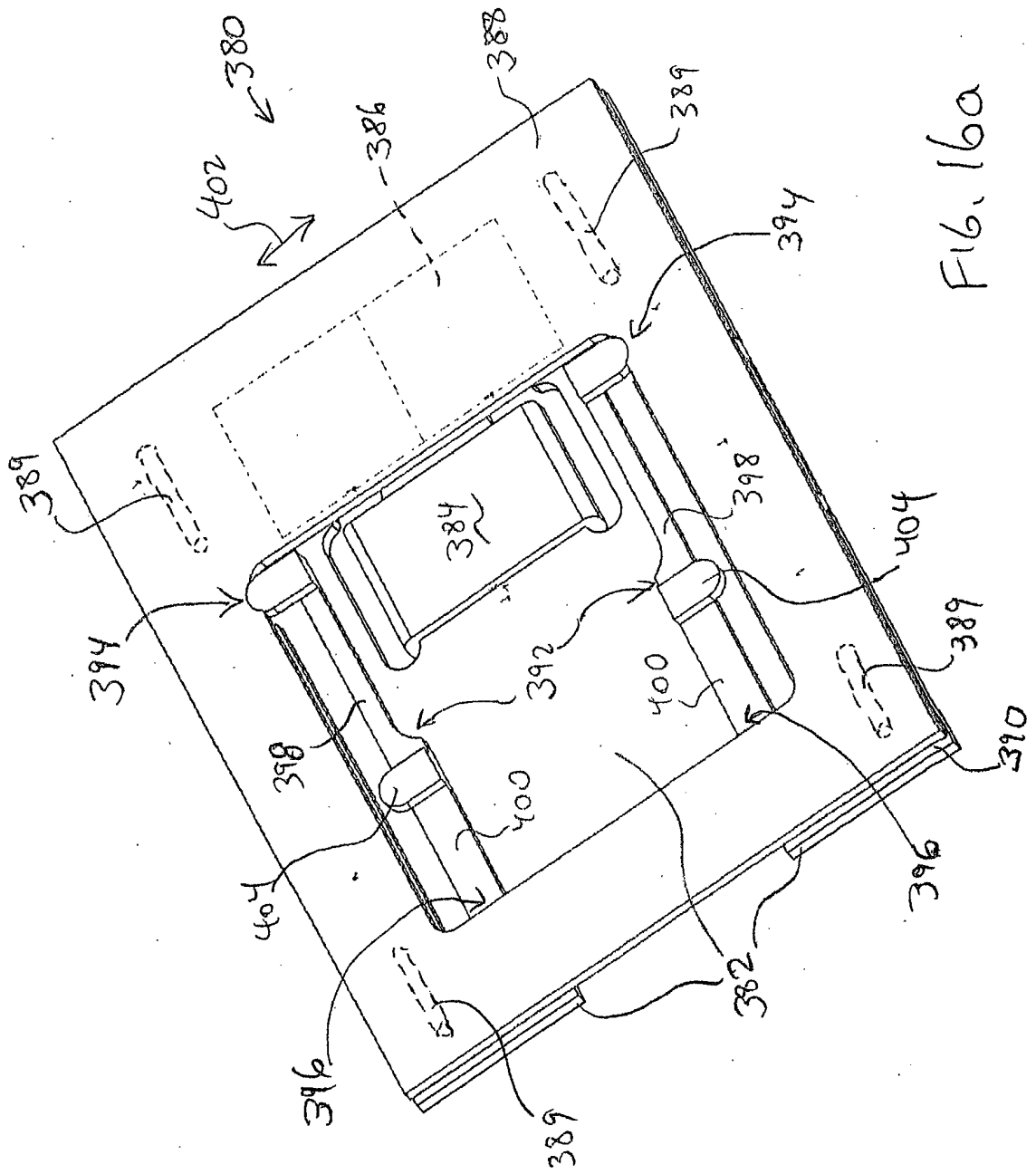

FIG. 16a

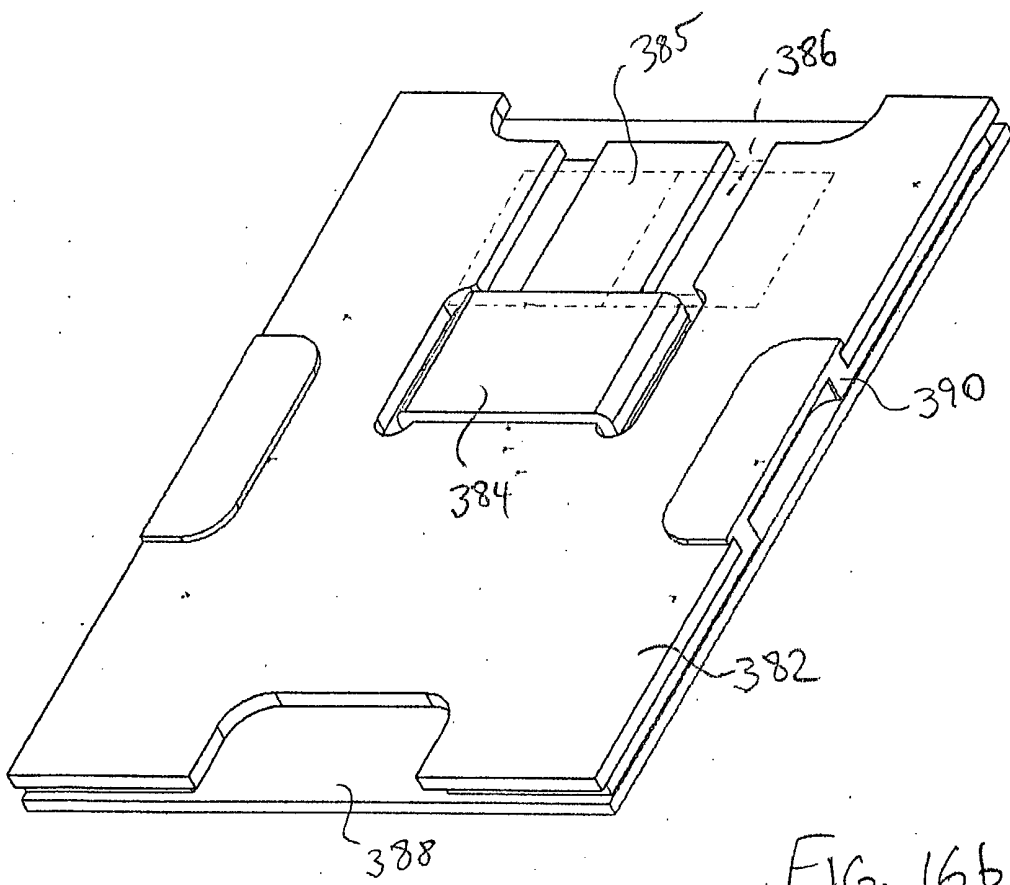

FIG. 16b

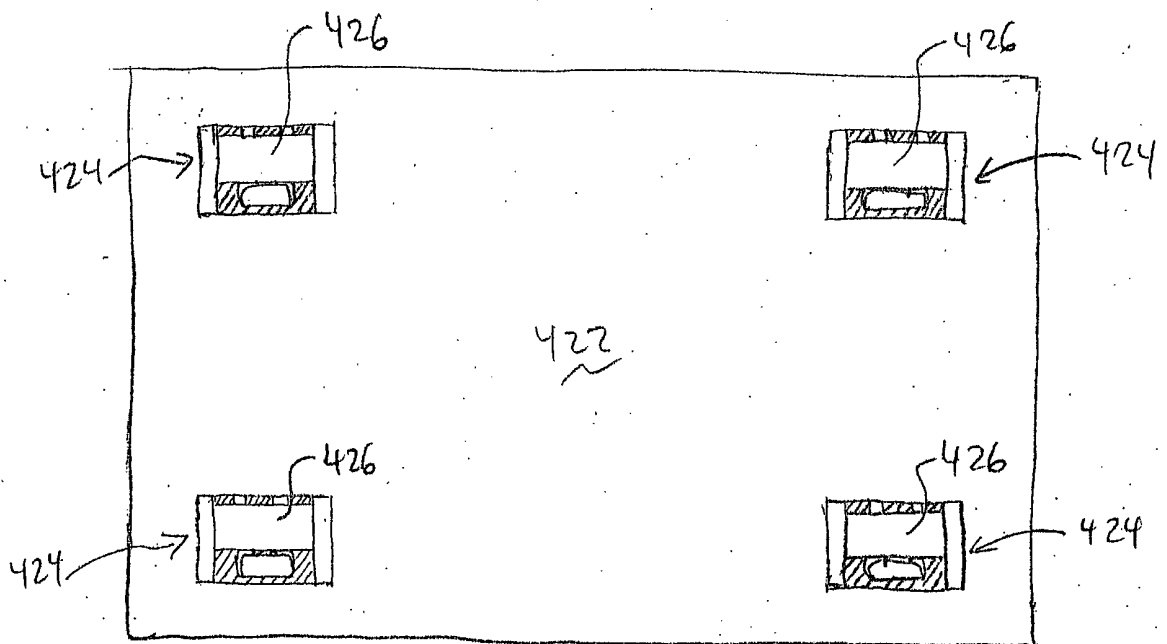
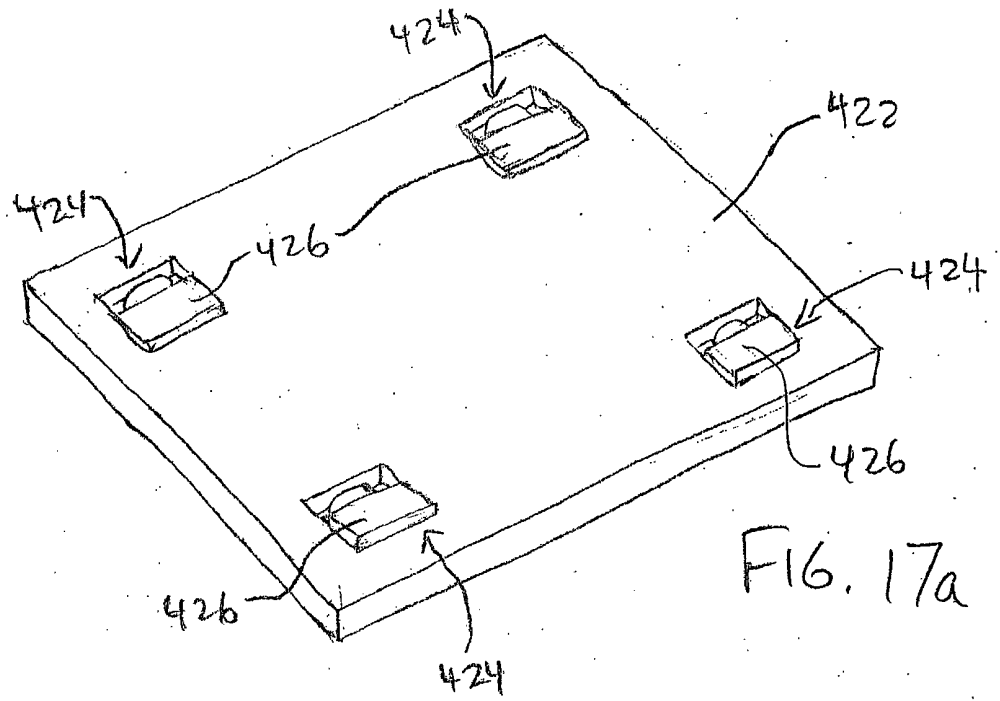

FIG. 17b

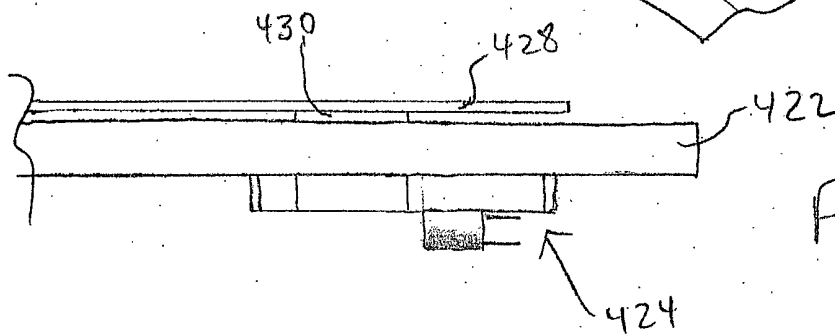
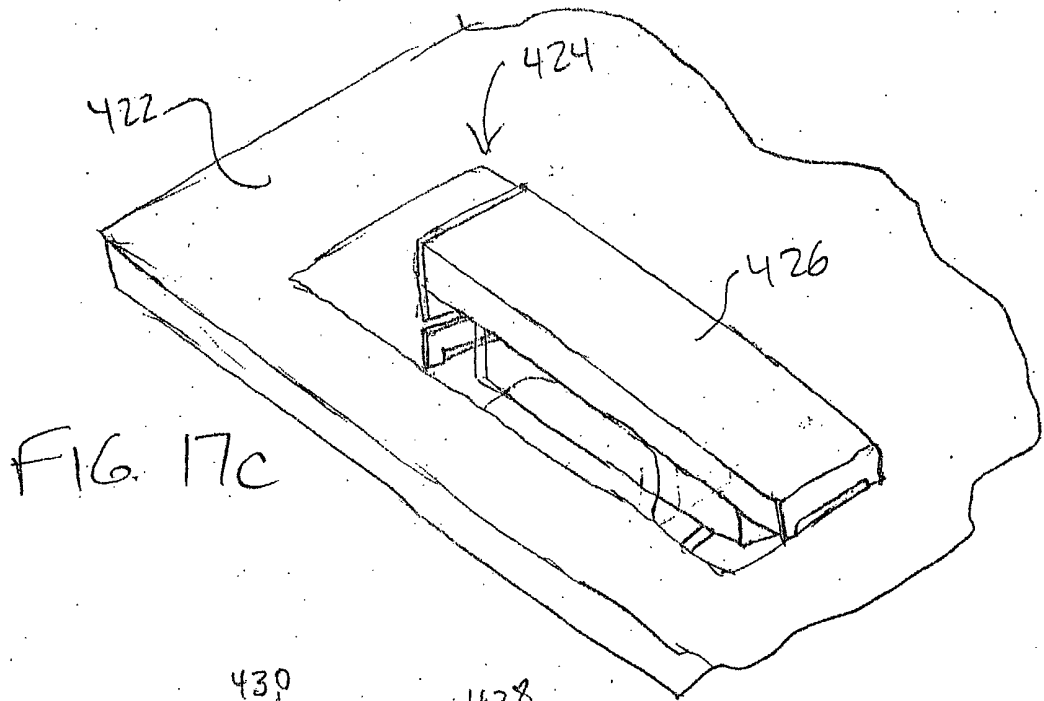

FIG. 17d

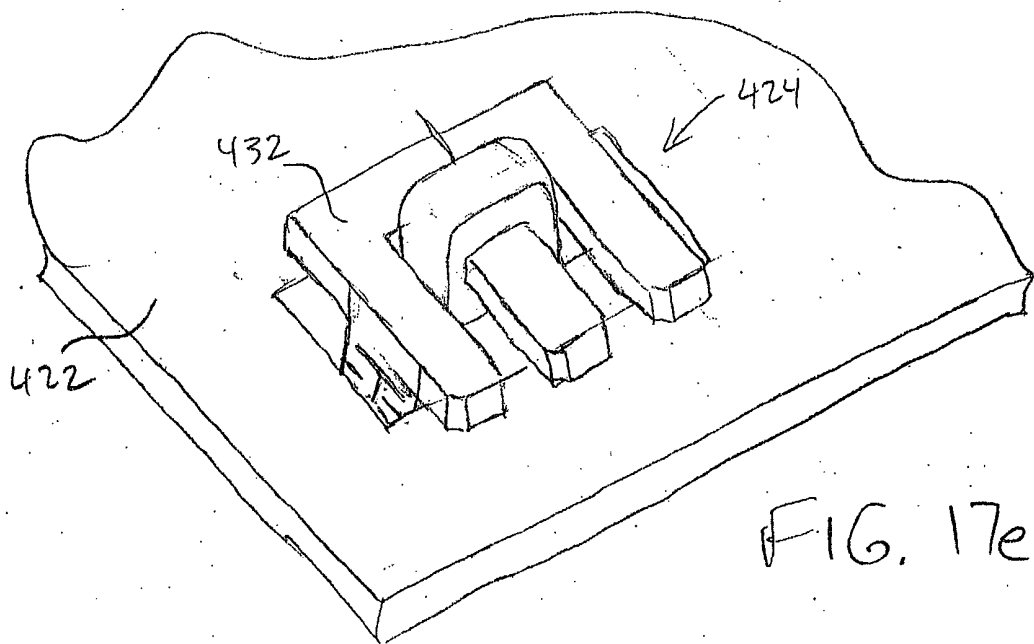

FIG. 17e



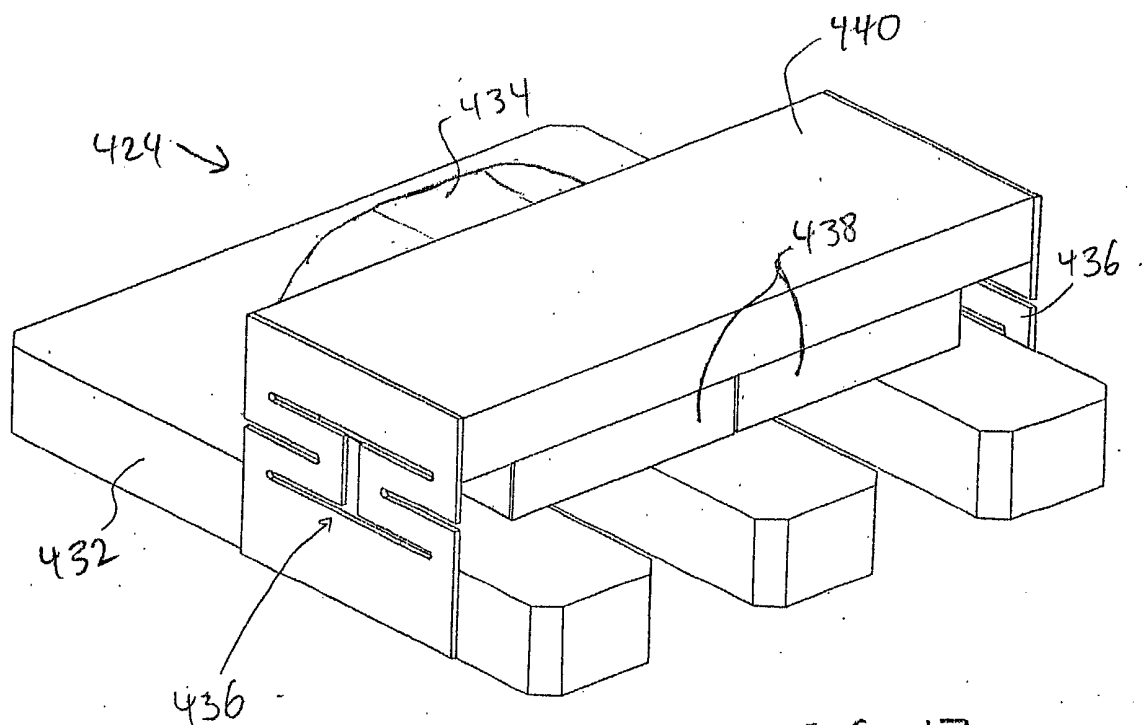
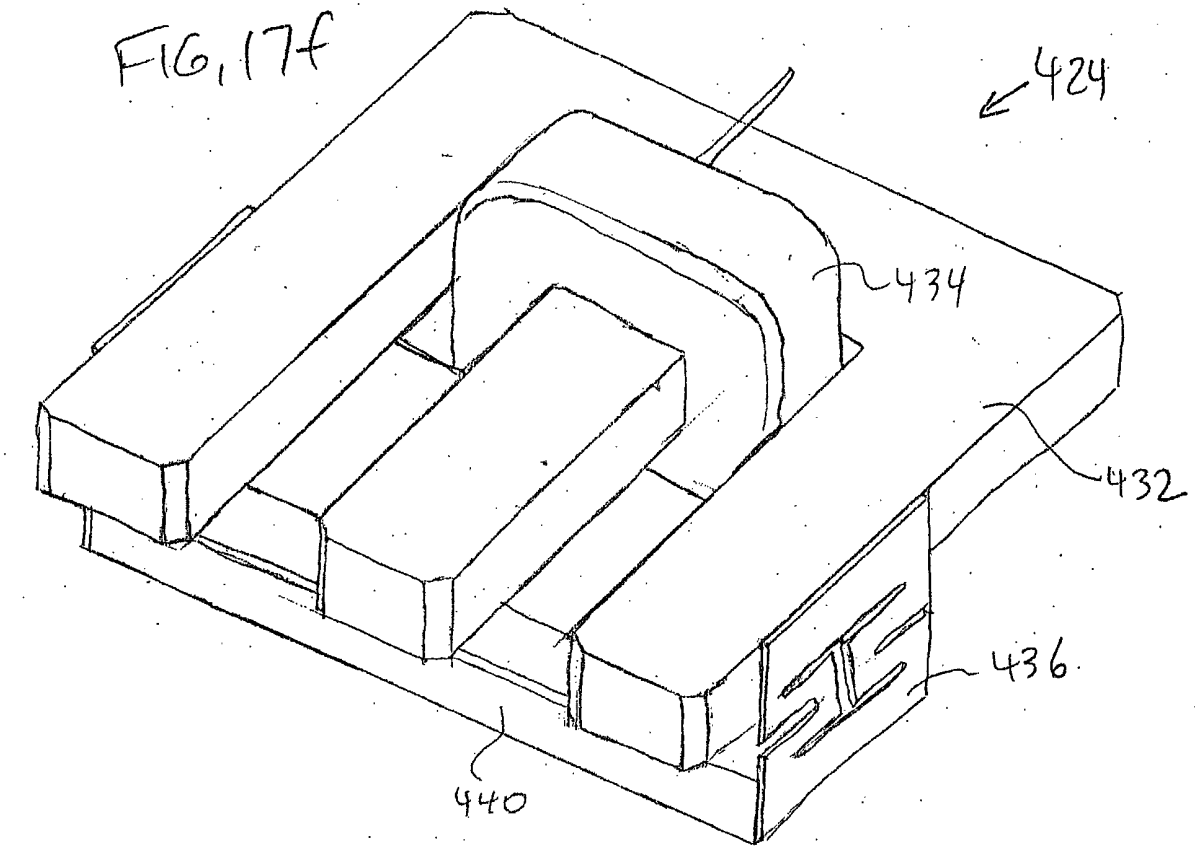

FIG. 17g

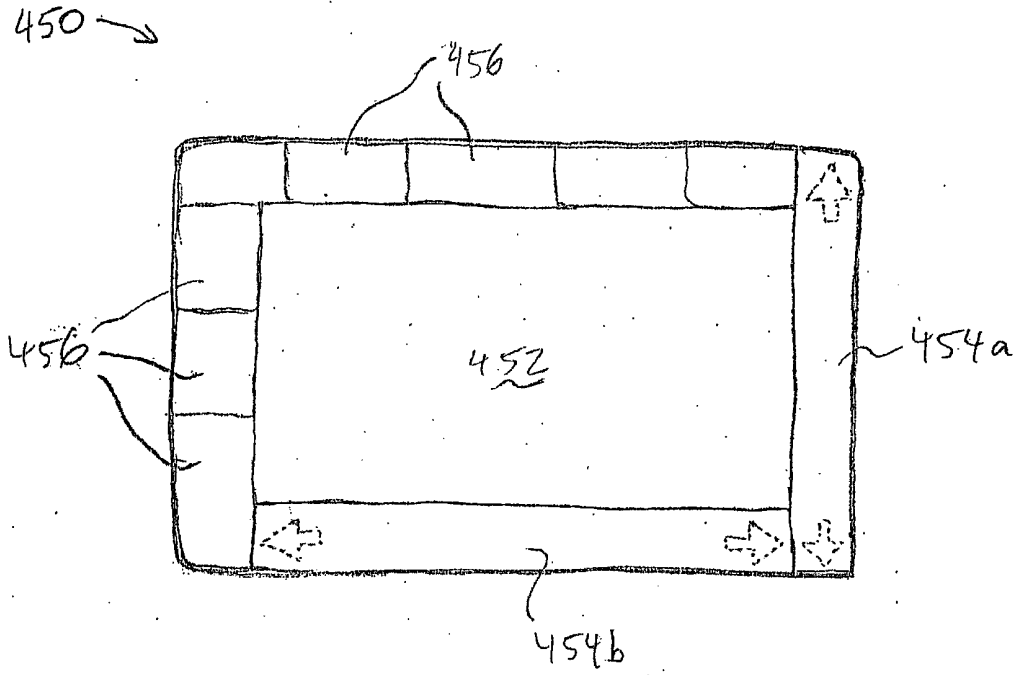

FIG. 18

**INTERNATIONAL SEARCH REPORT**

International application No.

PCT/US02/07102

<b>A. CLASSIFICATION OF SUBJECT MATTER</b>												
IPC(7) : G09G 5/00												
US CL : 345/156, 157, 161, 169												
According to International Patent Classification (IPC) or to both national classification and IPC												
<b>B. FIELDS SEARCHED</b>												
Minimum documentation searched (classification system followed by classification symbols) U.S. : 345/156, 157, 161, 169												
Documentation searched other than minimum documentation to the extent that such documents are included in the fields searched												
Electronic data base consulted during the international search (name of data base and, where practicable, search terms used) WEST												
<b>C. DOCUMENTS CONSIDERED TO BE RELEVANT</b>												
Category *	Citation of document, with indication, where appropriate, of the relevant passages	Relevant to claim No.										
A	US 5,988,902 A (HOLEHAN) 23 November 1999 (23.11.1999), see abstract.	1-44										
A	US 5,887,995 A (HOLEHAN) 30 March 1999 (30.03.1999), see abstract.	1-44										
A	US 4,692,756 A (CLARK) 08 September 1987 (08.09.1987), see column 3, lines 22-66.	1-44										
<input type="checkbox"/> Further documents are listed in the continuation of Box C. <input type="checkbox"/> See patent family annex.												
<p>* Special categories of cited documents:</p> <table border="0"> <tr> <td>"A" document defining the general state of the art which is not considered to be of particular relevance</td> <td>"T" later document published after the international filing date or priority date and not in conflict with the application but cited to understand the principle or theory underlying the invention</td> </tr> <tr> <td>"E" earlier application or patent published on or after the international filing date</td> <td>"X" document of particular relevance; the claimed invention cannot be considered novel or cannot be considered to involve an inventive step when the document is taken alone</td> </tr> <tr> <td>"L" document which may throw doubts on priority claim(s) or which is cited to establish the publication date of another citation or other special reason (as specified)</td> <td>"Y" document of particular relevance; the claimed invention cannot be considered to involve an inventive step when the document is combined with one or more other such documents, such combination being obvious to a person skilled in the art</td> </tr> <tr> <td>"O" document referring to an oral disclosure, use, exhibition or other means</td> <td>"&amp;" document member of the same patent family</td> </tr> <tr> <td>"P" document published prior to the international filing date but later than the priority date claimed</td> <td></td> </tr> </table>			"A" document defining the general state of the art which is not considered to be of particular relevance	"T" later document published after the international filing date or priority date and not in conflict with the application but cited to understand the principle or theory underlying the invention	"E" earlier application or patent published on or after the international filing date	"X" document of particular relevance; the claimed invention cannot be considered novel or cannot be considered to involve an inventive step when the document is taken alone	"L" document which may throw doubts on priority claim(s) or which is cited to establish the publication date of another citation or other special reason (as specified)	"Y" document of particular relevance; the claimed invention cannot be considered to involve an inventive step when the document is combined with one or more other such documents, such combination being obvious to a person skilled in the art	"O" document referring to an oral disclosure, use, exhibition or other means	"&" document member of the same patent family	"P" document published prior to the international filing date but later than the priority date claimed	
"A" document defining the general state of the art which is not considered to be of particular relevance	"T" later document published after the international filing date or priority date and not in conflict with the application but cited to understand the principle or theory underlying the invention											
"E" earlier application or patent published on or after the international filing date	"X" document of particular relevance; the claimed invention cannot be considered novel or cannot be considered to involve an inventive step when the document is taken alone											
"L" document which may throw doubts on priority claim(s) or which is cited to establish the publication date of another citation or other special reason (as specified)	"Y" document of particular relevance; the claimed invention cannot be considered to involve an inventive step when the document is combined with one or more other such documents, such combination being obvious to a person skilled in the art											
"O" document referring to an oral disclosure, use, exhibition or other means	"&" document member of the same patent family											
"P" document published prior to the international filing date but later than the priority date claimed												
Date of the actual completion of the international search 09 May 2002 (09.05.2002)		Date of mailing of the international search report <b>12 JUN 2002</b>										
Name and mailing address of the ISA/US Commissioner of Patents and Trademarks Box PCT Washington, D.C. 20231 Facsimile No. (703)305-3230		Authorized officer Ronald Laneau Telephone No. (703) 305-3973 <i>Ronald Laneau</i>										