

Sept. 18, 1956

R. E. SHVETZ

2,763,405

CONTAINERS FOR FLOWABLE SEMI-SOLID MATERIALS

Filed Jan. 25, 1954

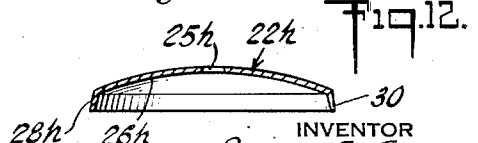
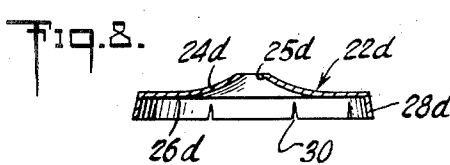
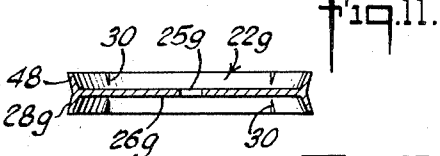
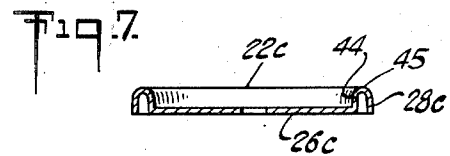
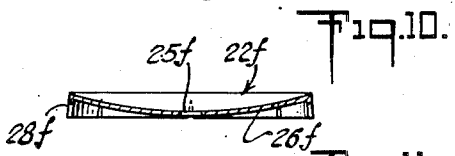
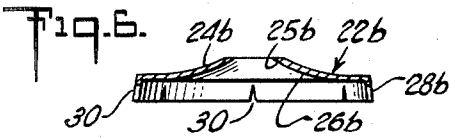
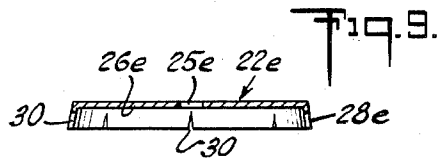
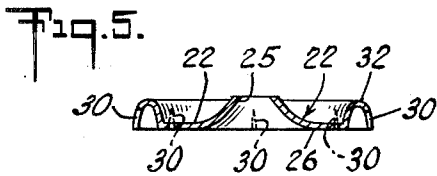
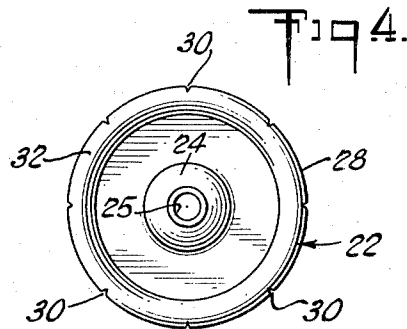
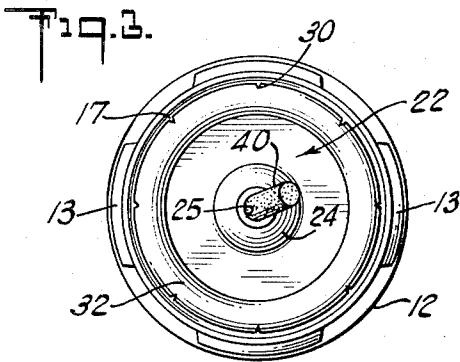
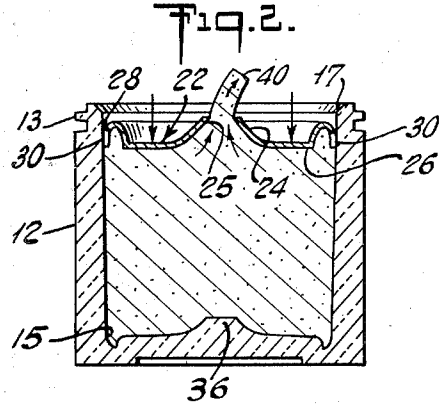
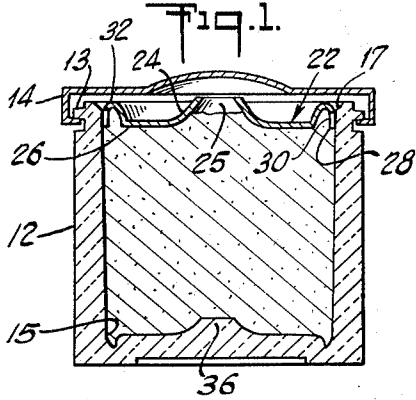

INVENTOR
ROMAN E. SHVETZ
BY
Robert Irving Williams
ATTORNEY

1

2,763,405

CONTAINERS FOR FLOWABLE SEMI-SOLID MATERIALS

Roman E. Shvets, New York, N. Y.

Application January 25, 1954, Serial No. 405,932

3 Claims. (Cl. 222—320)

This application is a continuation-in-part of my co-pending application Serial No. 352,917, filed May 4, 1953, now abandoned.

This invention relates to containers, and especially to containers of flowable semi-solid materials such as cold creams and a wide variety of ointments which are normally sold in jars and dipped therefrom with the user's finger. When such materials are dipped out of a jar by the finger, they tend to spread all over the finger and to get under the finger nails, with, in many instances, messy and dirt-gathering results. In addition, there is a tendency for the material to be pushed over the edge of the container due to the pressure of the finger as it dips into the contents, with the result that the container is unsightly, and, if a screw cap is used, that the material remains in the screw thread.

I have found that the necessity of dipping the finger into such creams and ointments can be avoided by the provision of an auxiliary interior cover which is formed of stiff, flexible material, which has an opening therein thru which the contents may be extruded when pressure is applied to the interior cover, and a resilient peripheral portion which is offset laterally before insertion into the jar, and which bears outwardly against the sides of the jar when in place. In this manner the cover may be so disposed in the container that the tendency toward extrusion of material at the sides of the cover can be substantially eliminated. The interior cover serves additionally to prevent the drying or other deterioration of the contents. I have also found that by forming a cover of transparent material, the appearance of the contents can be greatly improved.

The invention accordingly comprises an article of manufacture possessing the features, properties, and the relation of elements which will be exemplified in the articles hereinafter described and the scope of the application of which will be indicated in the claims.

For a fuller understanding of the nature and objects of the invention, reference should be had to the following detailed description taken in connection with the accompanying drawings, in which:

Figure 1 is a transverse sectional view of one form of container embodying the invention;

Fig. 2 is a similar view showing the cap removed and the interior cover in operation;

Fig. 3 is a top view thereof;

Fig. 4 is a top view of the interior cover;

Fig. 5 is a sectional view along the line 5—5 of Fig. 4;

Fig. 6 is a similar view of another form of interior cover embodying the invention in certain of its aspects;

Fig. 7 is a similar view of still another form of interior cover embodying the invention in certain of its aspects;

Fig. 8 is a similar view of a third form of interior cover embodying the invention in certain of its aspects;

Fig. 9 is a similar view of a fourth form of interior cover embodying the invention in certain of its aspects;

Fig. 10 is a similar view of a fifth form of interior cover embodying the invention in certain of its aspects;

2

Fig. 11 is a similar view of a sixth form of interior cover embodying the invention in certain of its aspects; and

Fig. 12 is a similar view of a seventh form of interior cover embodying the invention in certain of its aspects.

In the form of construction exemplified in Figs. 1-5, there is provided a container comprising a container-portion in the nature of a jar 12 having a neck formed with securing-threads 13 to which a cap-portion 14 may be secured by means of threads 13. The inner lateral wall of the jar has a slight taper inwardly and downwardly which is exaggerated somewhat in the drawing, and has at its bottom an inwardly curved portion 15 and at its upper end a beveled portion 17. Over the contents 20 there is provided an interior cover 22 having, in the present instance, a turned-up central portion 24 formed with a central opening 25 which may be about the size and shape of any of the openings commonly provided in collapsible tubes. Beyond or including the central portion 24, the interior cover has a pressure surface 26, beyond which is an outwardly resilient peripheral portion which, in the present instance, is in the form of a flange 28 which is offset laterally and adapted to bear, when in place, against the interior side wall of the jar so as to provide a resistance to inward movement of the interior cover, and to provide a tight closure at the sides of the interior cover. In order to facilitate such action to enable the interior cover to fit all parts of the tapering and inwardly-curved portions of the interior side walls of the jar, the flange is formed with V-shaped notches 30—eight in the present instance—which extend upwardly and inwardly from its edge. As exemplified, the flange 28 is carried on an upwardly-bent rim-portion 32, to provide a rim 34 which is U-shaped in cross section.

As exemplified, the interior cover is formed of stiff, flexible, transparent material such as Plexiglas or Vinylite and has a thickness of about one thirty-second of an inch; but it will be appreciated that the interior cover can be formed of any of a wide variety of stiff materials, ranging in thickness from one sixty-fourth of an inch or less to one sixteenth of an inch or more, altho the use, especially at the peripheral portion, of flexible material is advantageous, as is also the formation of the interior cover of transparent material.

In order to avoid wasting the contents of the jar 12, the bottom is formed, in the present instance, with a central protuberance 36 corresponding in shape to the central portion 24 of the interior cover. As will be apparent, pressure on the interior cover, which can most conveniently be applied by the finger to the pressure surface 26, will tend to move the cover downwardly and to cause the extrusion of a column 40 of the cream, ointment, or other flowable contents of the jar thru the opening 25.

As will be appreciated, the invention is capable of embodiment in various forms, both complex and simple. A simple form of interior cover is shown in Fig. 6. This is shown at 22b and comprises a turned-up central portion 24b, a central opening 25b, an upper pressure surface 26b, and a laterally-offset, resilient, downwardly-extending peripheral flange 28b, having V-shaped notches 30. This interior cover, and those mentioned below, may be formed similarly to the cover described above.

In Fig. 7 the cover 22c has a flat pressure surface 26c and an inverted U-shaped rim comprising an upwardly-extending rim portion 44, a resilient bent portion 45, and a dependent resilient flange 28c. Notches (not shown) are provided.

In Fig. 8 there is shown an arrangement similar to that of Fig. 6. The interior cover 22d has a turned-up central portion 24d with an opening 25d smaller than the openings 25 or 25b, a pressure surface 26d, and a laterally-offset, resilient flange 28d. Notches 30 are provided.

3

In Fig. 9 there is shown an interior cover 22e wherein a central opening 25e is formed in a flat disc which provides a pressure surface 26e and from which a laterally-offset resilient flange 28e depends. Notches 30 are provided.

In Fig. 10 there is shown an interior cover 22f wherein a central opening 25f is formed in a concave member which provides a pressure surface 26f and from which a flange 28f corresponding to the flange 28e depends.

In Fig. 11 there is shown an interior cover 22g is formed in a flat disc which provides a pressure surface 26g and from which laterally-offset resilient flanges 48 and 28g rise and depend respectively. Notches 30 (four in the present instance) are provided in each flange.

In Fig. 12 there is shown an interior cover 22h wherein a central opening 25h is formed in a convex member which provides a pressure surface 26h and from which a laterally-offset resilient flange 28h depends. The flange, as exemplified, is formed with a single notch 30 as shown at its right-hand side.

Since certain changes may be made in the above article and different embodiments of the invention could be made without departing from the scope thereof, it is intended that all matter contained in the above description or shown in the accompanying drawing shall be interpreted as illustrative and not in a limiting sense.

I claim:

1. A dispenser for flowable semi-solid materials comprising a container, a cap, and an interior cover having an opening thru which a column of the flowable material may be extruded when pressure is applied to the upper surface of the interior cover, said interior cover having a peripheral resilient flange extending vertically and outwardly and having in the edge thereof notches extending generally vertical from the edge thereof, and having a normally wider portion at said edge than vertically thereof.

4

2. A dispenser for flowable semi-solid materials comprising a container, a cap, and an interior cover having an opening thru which a column of the flowable material may be extruded when pressure is applied to the upper surface of the interior cover, said interior cover having a peripheral portion which extends generally vertically in one vertical direction and then vertically and outwardly in the opposite vertical direction to provide a peripheral flange, said flange being outwardly resilient and having cuts therein enabling the same to be collapsed against its resiliency.

3. A dispenser for flowable semi-solid materials comprising a container having inner walls converging slightly downwardly and a dispensing cover therefor having an opening thru which a column of the flowable material may be extruded when pressure is applied to the surface of the interior cover, said cover having a peripheral portion which corresponds to an inverted U in cross section to form a peripheral outwardly resilient flange having edge portions cut away to permit the collapse of the flange as the cover is moved downwardly within the container, the bottom of said container being formed with an annular depression to receive said flange when said cover reaches the bottom thereof.

References Cited in the file of this patent

UNITED STATES PATENTS

450,754	Golding	Apr. 21, 1891
1,603,013	Bagley	Oct. 12, 1926
2,120,007	Tear	June 7, 1938
2,231,412	McCarthy	Feb. 11, 1941
2,487,642	De Waltoff	Nov. 8, 1949
2,661,126	Spencer	Dec. 1, 1953

FOREIGN PATENTS

632,896	France	Oct. 17, 1927
---------	--------	---------------