

(12) PATENT APPLICATION
(19) AUSTRALIAN PATENT OFFICE

(11) Application No. AU 200214701 A1

(54) Title
Step up converter in an architectural covering device

(51)⁷ International Patent Classification(s)
H02M 007/30 H02P 009/08

(21) Application No: **200214701**

(22) Application Date: **2002.01.30**

(30) Priority Data

(31) Number	(32) Date	(33) Country
01300816	2001.01.30	EP

(43) Publication Date : **2002.08.01**

(43) Publication Journal Date : **2002.08.01**

(71) Applicant(s)
Turnils A.B.

(72) Inventor(s)
Anne J. Osinga; Jochem Welvaadt

(74) Agent/Attorney
BALDWIN SHELSTON WATERS,Level 21,60 Margaret Street,SYDNEY NSW 2000

ABSTRACT

The invention relates to a drive assembly (45, 46, 52) for a covering of an architectural opening, comprising a motor drive (52), an accumulator (54) connected to the motor drive, a power source (45) and an electrical circuit (55) connecting the power source to the accumulator. The electrical circuit comprises a step-up converter. Preferably, the step-up converter comprises an input terminal (11) connected to the power source (45), and an output terminal (12) with a supply voltage, connected to the accumulator (54), the voltage converting circuit (2) having:

- an input terminal (11) for connection to a varying voltage or current source, and an output terminal (12) with a supply voltage,
- an inductive element (5) being with a first terminal connected to the input terminal and with a second terminal to a capacitive element (8) and to the output terminal (12), the capacitive element (8) being with one terminal connected to a reference voltage (9),
- a first switch (6) being with a first terminal connected to the second terminal of the inductive element (5), and with a second terminal to the reference voltage (9), the first switch (6) comprising a gate electrode (31) for opening and closing of the switch when a control voltage of a first level is applied to the gate,
- an oscillator (13) comprising a power input (14) connected to the output terminal (12), a start-up output (15) connected to the gate electrode (31) of the first switch (6) for supplying a pulse-like signal to the gate electrode (31) and an oscillator output (16).

9/C

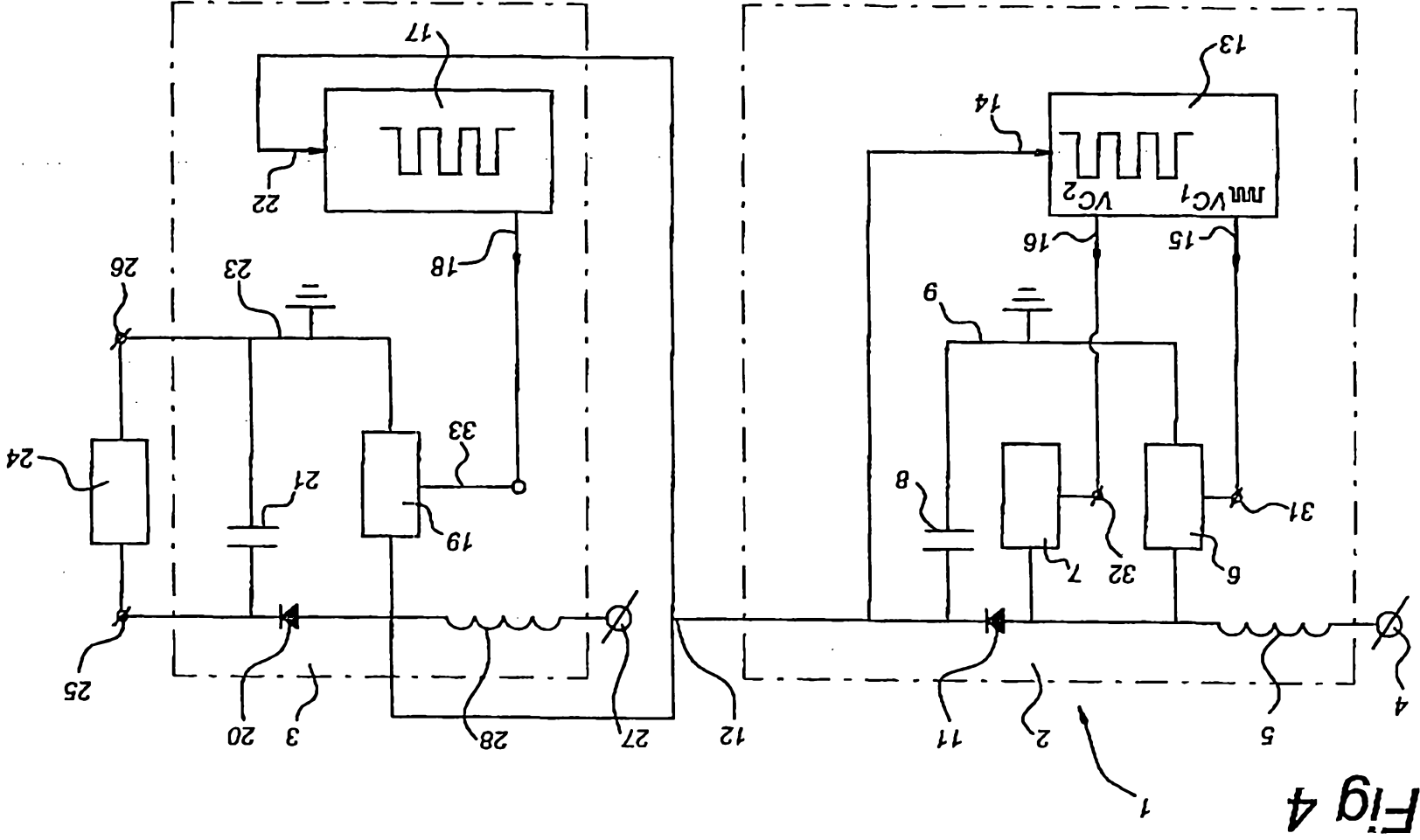

Fig 4

AUSTRALIA

PATENTS ACT 1990

COMPLETE SPECIFICATION

FOR A STANDARD PATENT

ORIGINAL

Name of Applicant: Turnils A.B.

Actual Inventors: Anne J. Osinga and Jochem Welvaadt

Address for Service: BALDWIN SHELSTON WATERS
60 MARGARET STREET
SYDNEY NSW 2000

CCN: 3710000352

Invention Title: 'STEP UP CONVERTER IN AN ARCHITECTURAL COVERING
DEVICE'

The following statement is a full description of this invention, including the best method of performing it known to us:-

File: 34416AUP00

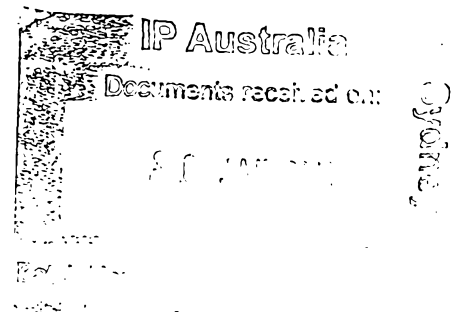

5 The invention relates to a drive assembly for a covering of an architectural opening, comprising a motor drive, an accumulator connected to the motor drive, a power source and an electrical circuit connecting the power source to the accumulator.

Light regulating devices, such as retractable and extendable awnings and control systems for automatically extending such awnings are known.

10 Motor driven venetian blinds comprising either vertical or horizontal slats are known, which can be opened by retracting the slats to one side of the window and in which the position of the slats around their longitudinal axis can be controlled electrically via a control unit, which fluid are powered from the mains power supply.

15 It is an object of the present invention to provide a drive assembly for a covering of an architectural opening, which can be operated electrically and which can be powered by a relatively low current or voltage power source.

It is in particular an object of the present invention to provide a drive assembly which can be operated by a photovoltaic cell of relatively small dimensions and operating at low light level conditions.

20 It is again an object of the present invention to provide a drive assembly using an electrical circuit connecting the power source to the accumulator, which is self-starting and which uses a relatively number of components.

It is a further object of the present invention to provide a drive assembly having an electrical circuit in which power losses are minimized and which is of compact design.

25 It is still a further object of the present invention to provide a drive assembly with an electrical circuit, which can operate at or near the maximum power point of a solar cell.

There to, the drive assembly according to the present invention is characterized in that the electrical circuit comprises a step-up converter.

30 The step-up converter transforms the small fluctuating voltage or current derived from the power source to DC current ranging from 1-20 V, suitable for charging the accumulator for operating the motor drive. Use of the step-up converter allows the drive assembly to be powered by a solar cell of small dimensions, which may be

mounted for instance at the inside of a window on the head rail of a venetian blind, facing towards the inside of the building, or being placed on any position on the windowsill.

5 An embodiment of the drive assembly according to the present invention comprises a step-up converter with an input terminal connected to the power source and an output terminal with a supply voltage, connected to the accumulator, the step-up converter circuit having:

- an input terminal for connection to a varying voltage or current source, and an output terminal with a supply voltage,
- 10 - an inductive element being with a first terminal connected to the input terminal and with a second terminal to a capacitive element and to the output terminal, the capacitive element being with one terminal connected to a reference voltage,
- a first switch being with a first terminal connected to the second terminal of the inductive element, and with a second terminal to the reference voltage, the first switch
- 15 comprising a gate electrode for opening and closing of the switch when a control voltage of a first level is applied to the gate,
- an oscillator comprising a power input connected to the output terminal, a start-up output connected to the gate electrode of the first switch for supplying a pulse-like signal to the gate electrode and an oscillator output.

20 The energy from the power source is stored in the inductive element and is periodically charging the capacitor for forming and increasing supply voltage on the output terminal. This increasing supply voltage is fed into the oscillator, which output signal rises as a consequence resulting in better control of the switch and hence more power being input into the capacitive element, such that the voltage of the output

25 terminal is increased.

In a preferred embodiment, the step-up converter further comprises a second switch connected in parallel with the first switch, the second switch having a gate electrode connected to the oscillator output, wherein the first switch remains opened when the supply voltage at the output terminal reaches a predetermined level, and the

30 second switch is operated by the oscillator output at a second voltage level that is higher than the first voltage level.

The varying input voltage is fed into the inductive element, which is periodically connected to reference voltage by opening of the first switch under control of the start-

up output of the oscillator. The power input of the oscillator is connected to the supply voltage terminal, which at start-up receives a very small voltage. The resulting start-up output voltage is correspondingly small, for instance 0.2 V or less. When the first switch is opened and closed again, a rising current is generated in the inductive element, which charges the capacitive element such that the supply voltage is successively increased. The first switch is particularly suited to be operated at a low gate control voltage from the start-up output of the oscillator. As the supply voltage increases, the start-up output signal of the oscillator will increase, resulting in better operation of the first switch and more power being transferred from the inductive element to the capacitive element, such that a self-amplifying effect results in increasing the supply voltage and the oscillator start-up output signal. When the supply voltage reaches a predetermined value, the first switch is de-activated (opened) and the second switch is operated from a second oscillator output, at a gate control voltage, which is above the gate control voltage of the first switch. Operation of the second switch results in a further increase in the supply voltage. The first switch may for instance be formed by a bipolar pnp- transistor with a gate control voltage of 0.6V above reference voltage, a collector-emitter voltage V_{ce} of 600 mV at a collector current I_c of 100 mA. The second switch may be formed by a low power logic level MOSFET with a gate control voltage V_{gs} (gate threshold voltage) generally in the range of 1-2V at a source voltage V_{ds} of 2V and at a current I_{ds} of 0.3-1.2A.

By the use of the two switches according to the present invention, each operating at a different gate control voltage level, a self-starting step-up converter is achieved.

In one embodiment, a diode is connected between the second terminal of the inductive element at the gate electrode of the first switch. When a varying supply voltage of about 0.4V is offered to the input terminal, and the supply voltage is about 0.4V, a 0.4V bias voltage on the control terminal of the first switch is maintained by the positive clamp formed by the diode. Hence, in case the first switch is formed by a pnp bipolar transistor, only a 0.2V varying control voltage is necessary at the gate to bring the transistor into conduction. The 0.2V varying voltage is obtained from the oscillator when powered at its input by a 0.4V supply voltage level.

In a further embodiment, the outputs of the oscillator are connected to the gates via respective capacitive elements. By the capacitive element coupling, the small DC

control voltage from the start-up output of the oscillator is added to the 0.4VDC level of the diode clamp.

5 A voltage converting unit may be formed by attaching a second converting stage to the voltage converting circuit, the second converting stage having an inductive element with a first terminal connectable to the varying voltage source, and connected with a second terminal to a first terminal of an electrical element such as an accumulator, the accumulator being with a second terminal connected to the reference voltage, a third switch being connected between the second terminal of the inductive element and the reference voltage and being with a gate electrode connected to an
10 oscillator output of a second oscillator, the supply voltage of the output terminal of the voltage converting circuit being connected to the second terminal of the inductive element and to a power input of the second oscillator. The third switch may be formed by a power MOSFET having multiple drains and multiple sources for further converting the DC-voltage from the converting circuit to levels of between 3-15V.

15 The voltage converting circuit according to the present invention may be applied in combination with a solar cell as a power source, a fuel cell or other varying voltage or current sources having relatively small current and voltages at their output. The voltage-converting unit according to the present invention may be part of a cattle watering unit, country road lighting or an electrical fence in the countryside when as a
20 voltage source a solar cell is used. Other applications in combination with a solar cell are digital billboards, billboard lighting, street lighting or information points.

Furthermore, the device of the present invention can be used to power speed control devices along roads, roadside reflectors or road markings (cat eyes), emergency points etc.

25 Alternatively, the voltage converting circuit can be applied in marine applications as a generator on boats, for boat lighting, as a navigation device or a GPS-system.

Mobile phones, laptops, organisers, and other appliances may be powered by the voltage converting circuit which only needs a very small voltage input.

30 Furthermore, digital cameras, battery chargers, bicycle lighting, danger triangles, avalanche beepers, flashlight, tv's, microwaves and other domestic appliances, garden lighting, garden sprayers and light regulating devices for windows, such as window blinds, awnings and etc. may be powered by the voltage converting circuit of the present invention.

The invention is most beneficial to small sized appliances by allowing a substantial reduction in surface of the solar cells.

Some embodiments of a voltage-converting unit according to the present invention will be explained in detail with reference to the accompanying drawings. In the drawings:

Fig. 1 shows an architectural covering device according to the present invention comprising a pleated light regulating device;

Fig. 2 shows an architectural covering device according to the present invention comprising a venetian blind;

Fig. 3 shows schematically the drive assembly according to the present invention;

Fig. 4 schematically shows an assembly of a voltage converting circuit according to the present invention in combination with a DC-DC step-up voltage converter connected to an electrical device;

Fig. 5 shows in detail the components of the voltage converting circuit and DC-DC converter of Fig. 1;

Fig. 6 shows an alternative embodiment of a voltage converting circuit according to the present invention wherein the second switch is controlled by a microprocessor;

Fig. 7 shows a schematic diagram of the input and output voltages of the inverters U_{1c} and U_{1f} ;

Fig. 8 shows an input voltage of inverter U_{1c} during start-up; and

Fig. 9 shows an output voltage of inverter U_{1c} inverter during start-up.

Fig. 1 shows a wall 40 having a window 41 along the upper end a head rail 42 of a pleated window covering 43 is mounted. On the head rail a drive assembly 44 is mounted comprising an array of photovoltaic cells (solar cells) 45 facing towards the interior of the wall 40, an electric drive assembly 46 comprising a drive motor, an accumulator and a step-up converter connecting the accumulator to the solar cells 45. The assembly 46 can be completely integrated into the head rail 42 or can be provided as a separate unit attached to the wall 40. Control unit 48 for raising or lowering the window covering 43 is connected to the drive assembly 46.

Fig. 2 shows an alternative embodiment of a window covering comprising a vertically deploying venetian blind, having horizontal slats 50 suspended from a head rail 42. Solar cells 45 are mounted on a windowsill and connected through electrical leads 51 to drive assembly 46. By operation of the control unit 48 the slats 50 may be

raised or lowered or may be changed in orientation by rotating around their longitudinal axes.

Fig. 3 schematically shows a drive assembly according to the present invention, comprising an electric motor 52 for raising or lowering the window covering and/ or changing the orientation of the slats 50, an electrical circuit 53, an accumulator or battery 54, a step-up converter 55 and a photovoltaic cell 45. The electrical circuit 53 may comprise a step-up converter for increasing the voltage derived from the battery 54. The battery 54 may comprise a metal hydride accumulator, an alkaline manganese battery, a lithium iron battery, or a plurality of lithium iron batteries in series.

In an embodiment, the accumulator has a capacity not exceeding 1.4 Ah. The battery may be a 3.6 V battery system, whereas the electric motor 52 may operate at 12 V DC at the power requirement not exceeding 50 mWh per day.

In a preferred embodiment the active operation of the electric motor 52 does not exceed 40 s per day.

Fig. 4 shows a step-up voltage converting unit 1 having a voltage converting circuit, or low voltage converter stage 2, connected to a second converter stage 3. The low voltage converter stage 2 comprises an input terminal 4, an inductive element 5, first and second switches 6, 7 and a capacitive element 8. Switches 6 and 7 are with a first terminal connected to the inductive element 5 and with a second terminal to a reference voltage line 9. The second terminal of capacitive element 8 is connected to the output of a diode 11 and to the supply voltage terminal 12. The supply voltage terminal 12 is connected to a power input 14 of oscillator 13. A start-up output 15 of the first oscillator 13 is connected to the gate electrode of switch 6 whereas the oscillator output 16 is connected to the gate electrode of switch 7. The supply voltage an output terminal 12 of low voltage converter stage 2 is connected to the second terminal of inductive element 28 and to a power input 22 of second oscillator 17 of second converter stage 3. The oscillator output 18 connects to the gate electrode of switch 19. A diode 20 and capacitive element 21 are connected between the inductive element 28 and reference voltage line 23. Electrical device 24 is connected across output terminals 25, 26 of second converter stage 3.

When at start-up a varying low voltage supply, such as a solar cell, is connected to input terminals 4 and 27 of the voltage converting unit 1, and switches 6, 7 are closed, the capacitive element 8 is charged, creating a small voltage on the output

terminal 12 and on oscillator power input 14. The small power input into the oscillator 13, results in a pulse shaped signal on start-up output 15 at a low gate control voltage level V_{c1} , which may be a few tenths of Volts, periodically opening and closing the switch 6 at the frequency of for instance 100 kHz. This causes a periodic current through the switch 6 resulting in a rising current through the inductive element 5, charging capacitor 8 that is rectified by diode 11 and results in an increasing voltage at the supply voltage terminal 12 and consequently at the power input of oscillator 13. This effect continues until the voltage level at supply terminal 12 reaches a predetermined level, after which low voltage controlled switch 6 is de-activated (opened) and high voltage controlled switch 7 is operated from oscillator output 16. The switch 7 is operated at a control voltage level V_{c2} until the supply voltage at supply voltage terminal 12 is for instance a few volts. The supply voltage is input into second converter stage 3 at the second terminal of inductive element 28 and into power input 22 of second oscillator 17. At oscillator output 18, a pulsed control signal operating the gate electrode of switch 19 is generated. By switching on and off the switch 19, the energy stored in inductive element 28 is transferred to capacitor 21 until a predetermined voltage level is reached. At this predetermined level, such as voltage levels between 1.5-12V, switch 19 is opened such that electrical energy is stored in inductive element 28, to be released again upon closing of the switch 19.

As the step-up voltage-converting unit 1 generates its own supply voltage from a situation of rest, the step-up converter is self-starting.

Fig. 5 shows in detail the components of the voltage converter stage 2 and second converter stage 3 according to the present invention. The following letter symbols apply:

- | | | | |
|----|-------------------------|---|--|
| 25 | T_1 | : | low power, logic level MOSFET; |
| | T_2 | : | switching MOSFET; power MOSFET; |
| | L_1 | : | switching coil with high inductance; |
| | L_4 | : | switching coil; |
| | D_1, D_2 | : | rectifying diodes; |
| 30 | C_9, C_{21}, C_1 | : | smoothing electrically controllable capacitors (elco's); |
| | $U_{1A}-U_{1F}; U_{1C}$ | : | low voltage inverter gates manufactured by Philips Electronics under type number 74HC14; |

D_4 : switching bipolar transistor;
 D_2, D_4 : Schottky diodes;
 C_3 : relatively small capacitor.

The second converter stage 3 operates according to known DC-DC voltage
 5 converter principles according to which the small fluctuating voltage V_{solar} at the
 input of coil 28 is stored in the coil when switching MOSFET 19 is opened. Upon
 closing of the switching MOSFET 19, the energy is released from the coil 28 and
 supplied via rectifier diode 20 to smoothing capacitors 21 resulting in an increased
 voltage across output terminals 25, 26. In order to be self-starting, voltage converter
 10 circuit or step-up circuit 2 is provided wherein the oscillator 13 is constructed of active
 component of the type of Philips low voltage inverter ports U_{1C} and U_{1F} . The inverter
 ports can generate at their output, voltages at an input voltage of V_{cc} of below 0.4V at
 start-up.

At low supply voltages V_{cc} , transistor T_3 is switched-off and a very low
 15 alternating voltage is supplied via start-up output 15 of oscillator 13 to a coupling
 capacitor C_2 and from thereon to the base 31 of transistor T_4 . Schottky diode D_4 is
 used as a positive clamp such that a small alternating voltage appears on the base 31
 with an offset of 0.4V. The solar cell voltage is about 0.4V. The transistor T_4 will go in
 conduction at a gate voltage of about 0.6V, such that the gate voltage need only be 0.2
 20 V in order to get transistor T_4 into conduction. It has appeared that the oscillating
 inverter gate U_{1C} of oscillator 13 can supply enough energy to get the transistor D_4 into
 conduction. This causes a periodic current in the collector c of transistor T_4 . Since the
 transistor T_4 is coupled with a switching coil with a relatively high inductance L_1 and
 a relatively small capacitor C_3 , the periodic current in the collector c results in an AC-
 25 voltage across the coil 5. This AC-voltage is rectified through Schottky diode D_2 and
 appears on supply voltage terminal 12 and is fed back at the supply of low voltage
 inverter gates U_{1C} - U_{1F} . Each time V_{cc} rises, the voltage level at the start-up output 15
 of the oscillator 13 rises, resulting in better control of switching transistor T_4 . Proper
 gating of transistor T_4 results in more power being stored in coil 5, increasing supply
 30 terminal voltage V_{cc} etc. At the outlet 30 of the oscillator U_{1C} , a coupling capacitor C_4

is provided which operates a low voltage inverter gate U_{1E} . The output of the oscillator U_{1E} is connected to the control gate of a low power logic level of the MOSFET T_1 . The coupling capacitor C_4 ensures that the MOSFET of T_1 switches at the beginning or start-up in phase with transistor T_4 .

5 When the supply voltage V_{cc} rises above the threshold level of logic level MOSFET T_1 , transistor T_3 goes into conduction, pulling the input of oscillator U_{1E} to ground such that first transistor T_4 is switched-off and logic level MOSFET T_1 takes over. Now V_{cc} can rise to for instance 3 V wherein the final power conversion up to voltages ranging from 1.5-12.0 V is effected by power MOSFET T_2 of second converter stage 3. When V_{cc} reaches its desired end level, the varying supply level V_{solar} will place transistor T_3 in conduction pulling the input of oscillator U_{1E} to ground and de-activating switch T_2 .

10

Fig. 6 shows another embodiment of a low voltage solar converter including a step-up DC-DC converter (sometime also called: a voltage increasing chopper). The main components of the step-up converter are:

15 inductor/inductance L_4 ; semiconductor switch T_4 and supplemental N-channel MOSFET T_2 ; diode D_1 (Schottky ZHCS 750) and capacitor/capacitance in the form of high capacity elco C_{23} compensated for low resistance by additional capacitors C_{19} and C_{20} . Semiconductor switch T_4 operates the step-up converter at those times when the

20 voltage is too low to operate the MOSFET switch T_2 . Switch T_4 is operated by an oscillator circuit as indicated in Fig. 3 by a dash-dotted box. The output of the oscillator connects to the start-up oscillator connector of the step-up converter where Schottky diode D_3 (ZHCS 750) adds the output voltage of the solar panel 425a to the pulsed voltage generated by the oscillator. The resulting voltage is offered to the base of T_4 .

25 As soon as the voltage offered to the step-up converter is high enough for the MOSFET switch T_2 to operate, the oscillator output is grounded through semiconductor T_3 of the oscillator circuit. Then the MOSFET T_2 is controlled from the "N-gate" output of the central micro processor 471 and a further P-channel MOSFET T_1 is controlled from the "P-gate" output of the processor 471 to take over from the Schottky diode D_1 . The

30 P and N-gates of the processor 471 are software driven. In this manner a particularly

advantageous step-up converter has been obtained. The alternative use of semiconductor switches T_4 and T_2 provides for a register of compound step-up converter that has optimal characteristics for each of a low voltage and a higher voltage range. The provision of Schottky diode D_3 enables to offer an as high as possible voltage to the base of the low voltage semiconductor switch T_4 . The additional MOSFET switch T_1 , which is positioned in parallel to diode D_1 , allows to eliminate the losses, which normally occur in diodes such as D_1 .

Fig. 7 shows the input and output voltages V_1 , V_0 of inverter ports U_{1C} and U_{1E} , which are inverting Schmitt-trigger inverter ports. Generally, at a supply voltage V_{cc} of 1V, the negative-going threshold V_{T1} will be about 0.5V, the positive-going threshold V_{T2} being several tenths of Volts higher. The output voltage V_0 will be limited to a maximum of supply voltage V_{cc} . The inventors have found out that at supply voltages V_{cc} below specification of the manufacturer, there is a region of the inverter port below V_{T1} at which at low supply voltage V_{cc} there still is a hysteresis in the output signal such that an oscillator can be obtained by feedback of in the output signal to the input via resistor R_2 . At a supply voltage of V_{cc} 0.4V the input at the inverter gate U_{1C} is given in Fig. 8, at a level of about 300 mV, at a frequency of about 4 kHz.

In Fig. 9, the output at inverter gate U_{1C} is given at a level of 400 mV with a frequency of about 20 kHz. Surprisingly, at low supply voltages V_{cc} and at low input levels below the negative-going threshold V_{T1} according to specifications, it is still possible to obtain an oscillator using inverter gate U_{1C} such that start-up of the step-up converter can be obtained by use of said component.

THE CLAIMS DEFINING THE INVENTION ARE AS FOLLOWS:-

1. Drive assembly for a covering of an architectural opening, comprising a motor drive, an accumulator connected to the motor drive, a power source and an electrical
5 circuit connecting the power source to the accumulator, characterized in that the electrical circuit comprises a step-up converter.

2. Drive assembly according to claim 1, wherein the step-up converter comprises an input terminal connected to the power source, and an output terminal with a supply
10 voltage, connected to the accumulator, the voltage converting circuit having:

- an input terminal for connection to a varying voltage or current source, and an output terminal with a supply voltage,
- an inductive element being with a first terminal connected to the input terminal and with a second terminal to a capacitive element and to the output terminal, the
15 capacitive element being with one terminal connected to a reference voltage,
- a first switch being with a first terminal connected to the second terminal of the inductive element, and with a second terminal to the reference voltage, the first switch comprising a gate electrode for opening and closing of the switch when a control voltage of a first level is applied to the gate,
- 20 - an oscillator comprising a power input connected to the output terminal, a start-up output connected to the gate electrode of the first switch for supplying a pulse-like signal to the gate electrode and an oscillator output.

3. Drive assembly according to claim 2, the step-up converter further comprising a
25 second switch connected in parallel with the first switch, the second switch having a gate electrode connected to the oscillator output, wherein the first switch remains opened when the supply voltage at the output terminal reaches a predetermined level, and the second switch is operated by the oscillator output at a second voltage level that is higher than the first voltage level.

30

4. Drive assembly according to claim 3, the first switch comprising a bipolar transistor and the second switch comprises a Field Effect Transistor.

5. Drive assembly according to claim 2, 3 or 4, wherein a diode is connected between the second terminal of the inductive element and the gate electrode of the first switch.

5 6. Drive assembly according to any of claims 2-5, wherein the output of the oscillator is connected to the gate via a respective capacitive element.

7. Drive assembly according to any of claims 2-6, wherein a second converting stage is provided having an inductive element with a first terminal connected to the
10 power source, an connected with a second terminal to the accumulator, a third switch being connected between the second terminal of the inductive element and the reference voltage and being with a gate electrode connected to an oscillator output of a second oscillator, the output terminal of the voltage converting circuit being connected to the second terminal of the inductive element of the second converting stage and to a power
15 input of the second oscillator.

8. Drive assembly according to claim 7, the third switch comprising a MOSFET with multiple drains and multiple sources.

20 9. Drive assembly according to claim 7 or 8, wherein the second inductive element is with its second terminal connected to the electrical element via a diode, the first terminal of the electrical element being connected via a capacitive element of the reference voltage.

25 10. Electrically operated architectural covering device comprising a drive assembly according to any of the preceding claims, and a covering member connected to the drive motor.

30 11. Architectural covering device according to claim 10, the power source comprising a photovoltaic cell.

12. Architectural covering device according to claim 11, the photovoltaic cell being placed on a head rail, a window sill or on a surface of the covering member, or on any combination thereof.

5 13. Architectural covering device according to claim 11 or 12, the photovoltaic cell being placed on an interior side of the covering member.

14. A drive assembly substantially as herein described with reference to any one of the embodiments of the invention illustrated in the accompanying drawings.

10

15. An architectural covering device substantially as herein described with reference to any one of the embodiments of the invention illustrated in the accompanying drawings.

15 DATED this 30th Day of January, 2002

TURNILS A.B.

Attorney: PETER R. HEATHCOTE
Fellow Institute of Patent and Trade Mark Attorneys of Australia
of BALDWIN SHELSTON WATERS

20

Fig 1

1/6

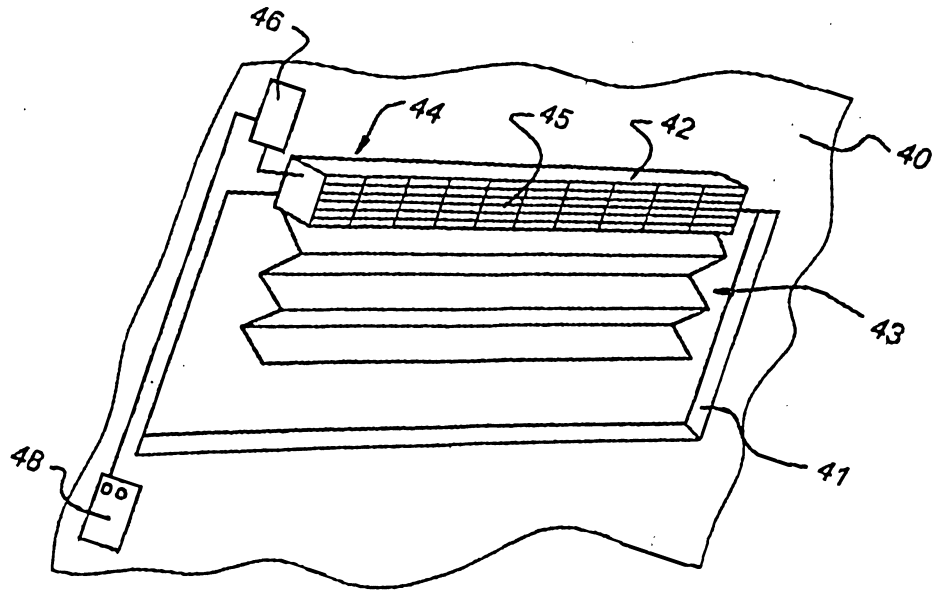

Fig 2

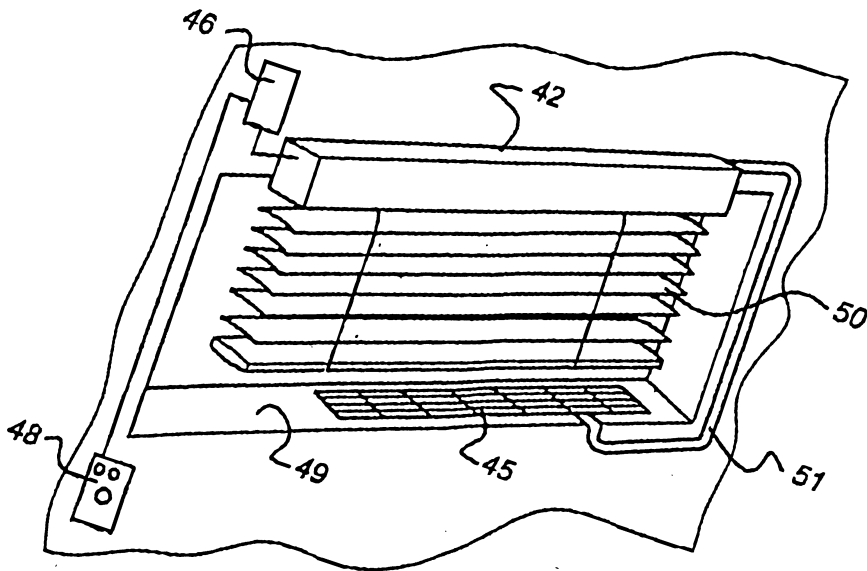

Fig 3

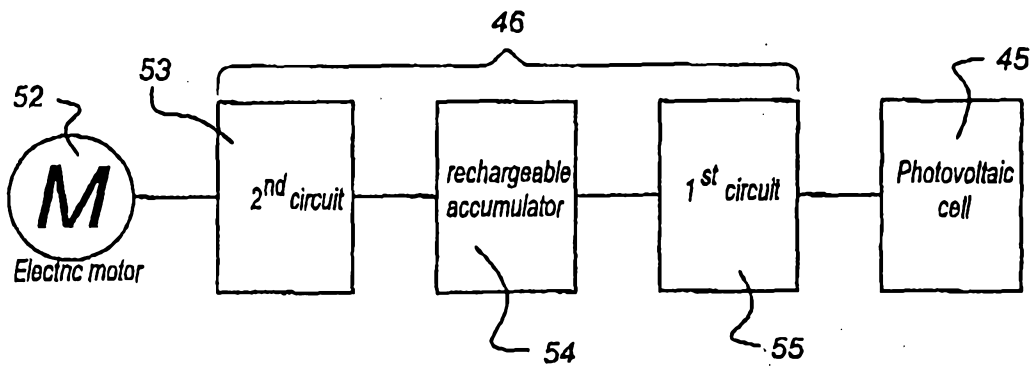
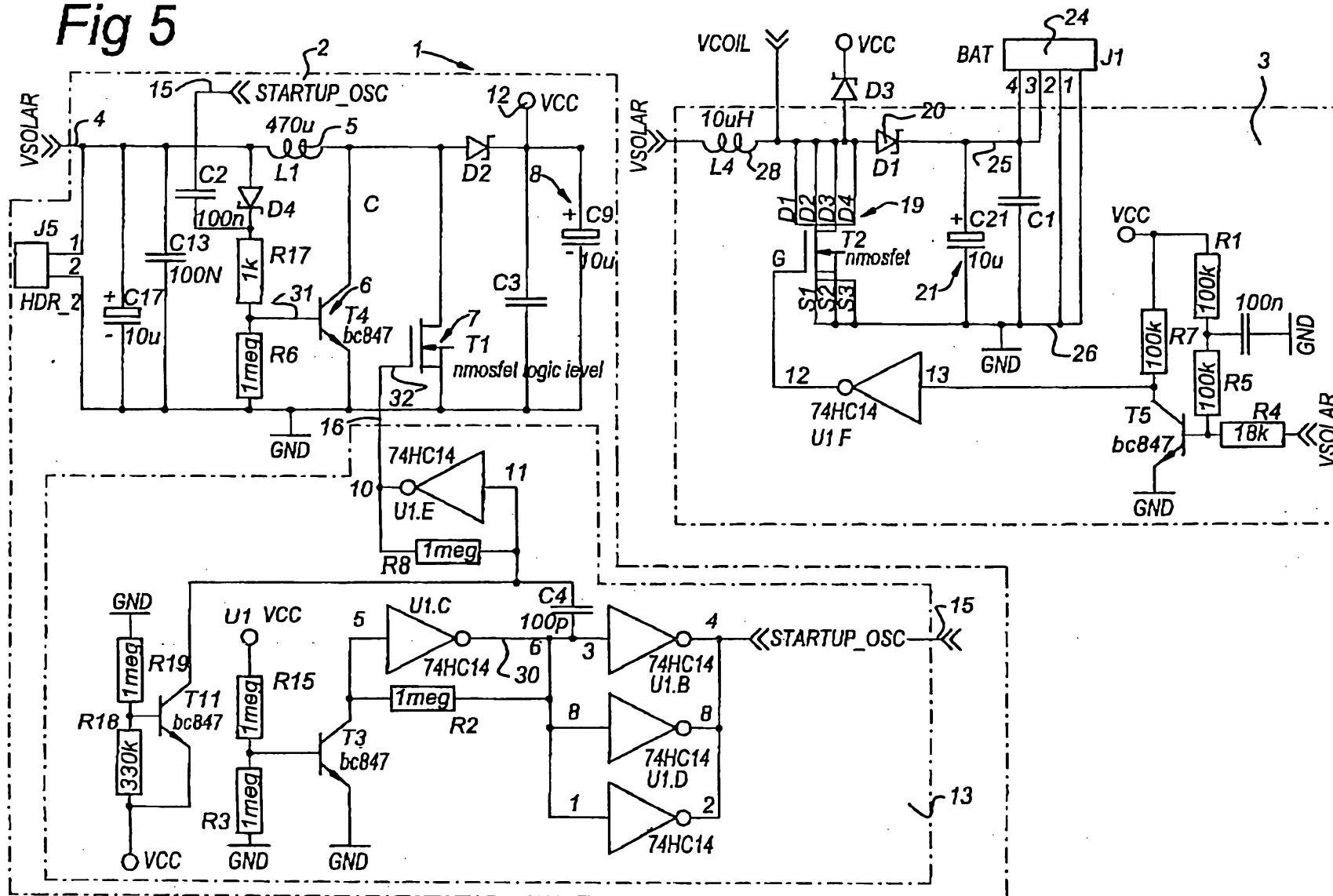

Fig 5



30 01 02 14701

Fig 6

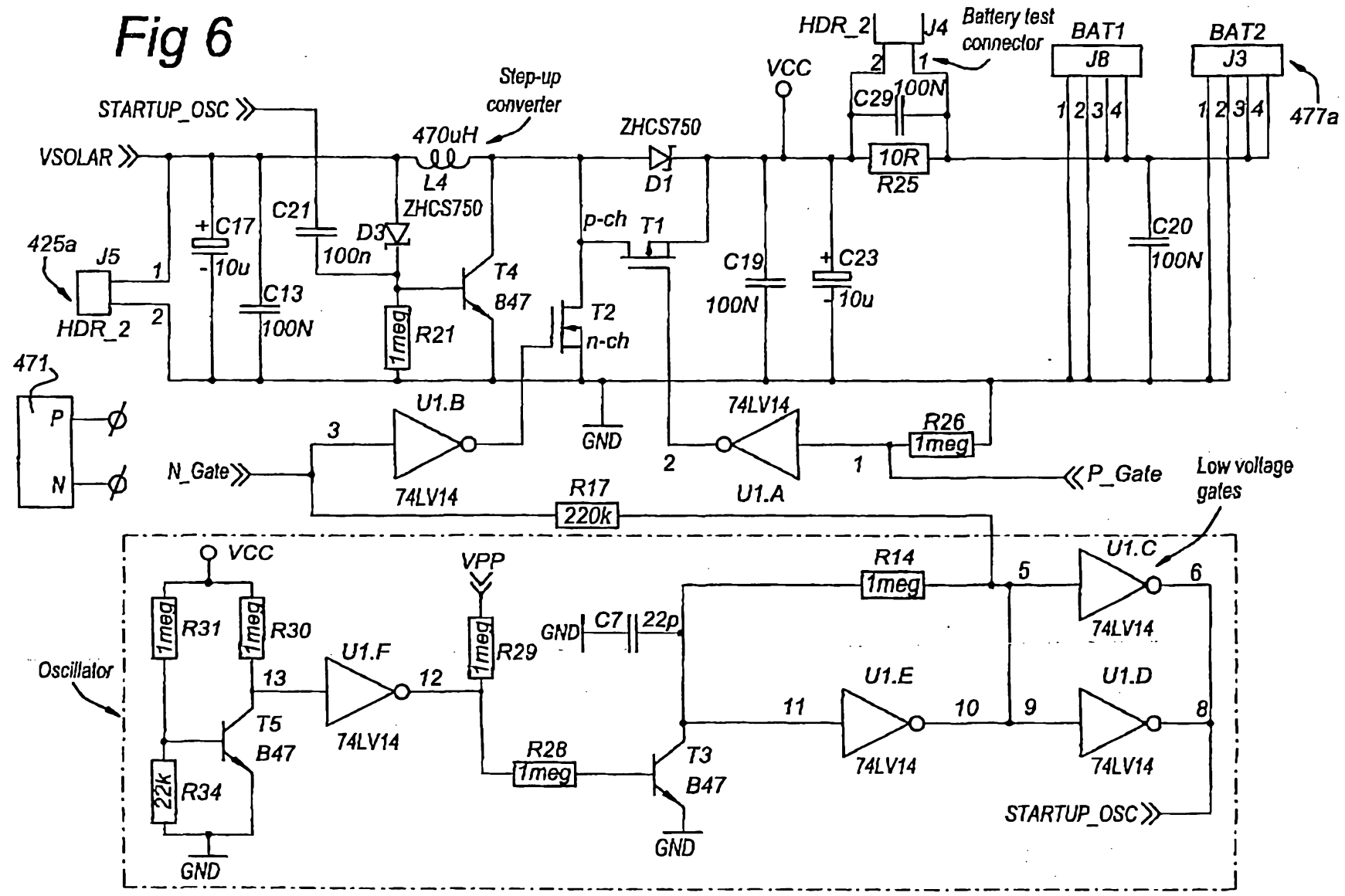

Fig 7

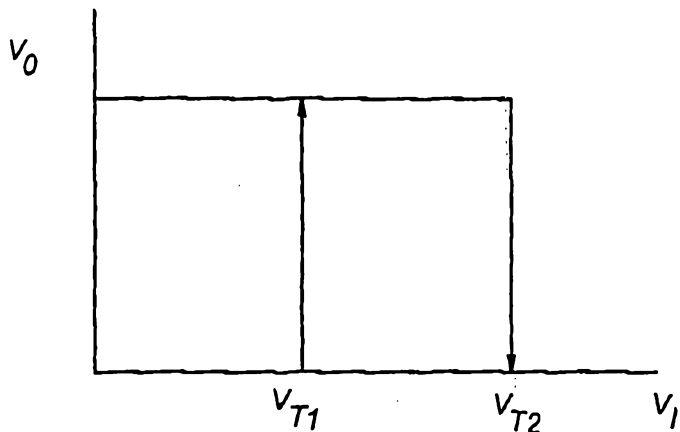

Fig 8

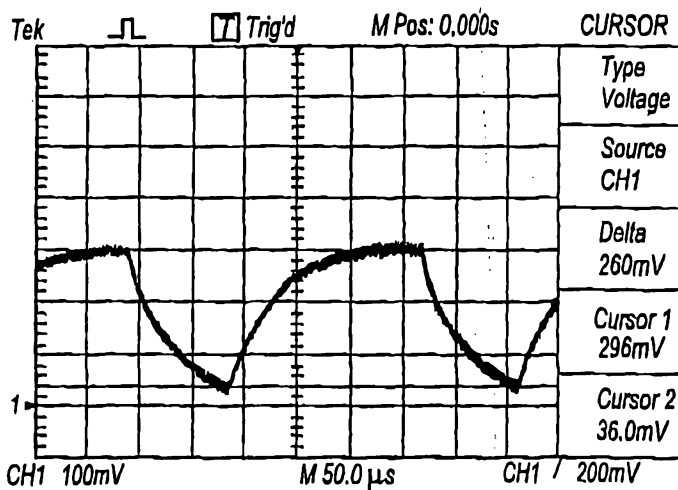

Fig 9

