

July 28, 1959

R. M. HELLER

2,897,473

BOOTED ELECTRICAL RECEPTACLE

Filed July 2, 1956

FIG. 1.

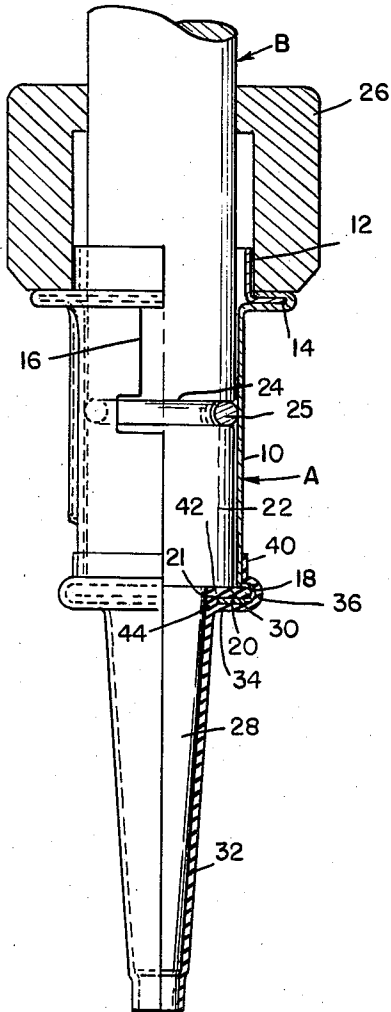
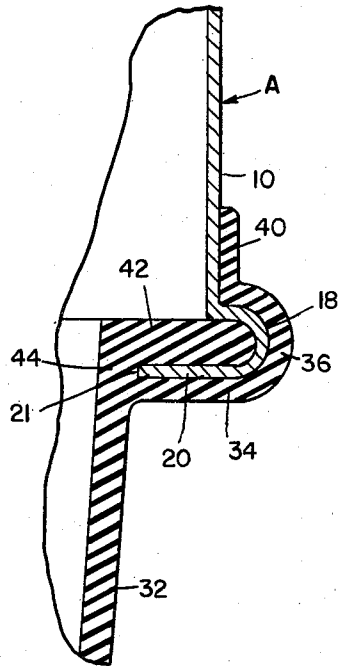

FIG. 2.



INVENTOR.

ROBERT M. HELLER

BY *Whittemore*

*Hulbert & Belknap*  
ATTORNEYS

1

2,897,473

**BOOTED ELECTRICAL RECEPTACLE**

Robert M. Heller, Birmingham, Mich., assignor to Watts Electric & Mfg. Co., Birmingham, Mich., a corporation of Michigan.

Application July 2, 1956, Serial No. 595,345

1 Claim. (Cl. 339—101)

The present invention relates generally to a booted electrical receptacle, and refers more particularly to a booted bulb socket, fuse holder, or the like, having an opening for an electrical conductor surrounded by an inwardly extending radial flange.

One of the objects of the present invention is to provide the shell of an electrical receptacle with a plastic boot having a coating portion adhering to the outer surface of the shell, having an inner annular anchorage portion, and having a portion extending through the opening aforesaid and connecting said outer coating portion to said inner anchorage portion.

Another object of the present invention is to provide an electrical receptacle as described in the preceding paragraph in which the plastic boot is provided endwise of the shell around the opening aforesaid with a tapered tubular sleeve for the electrical conductor.

Another object is to provide the electrical receptacle with a boot wherein the connecting portion aforesaid connects the sleeve to the anchorage portion within the shell.

More specifically, it is an object of the present invention to provide an electrical receptacle such as a bulb socket having a tubular shell provided at one end with a radially inwardly extending flange defining an opening for an electrical conductor, and a plastic boot having outer coating portions respectively covering the outer surface of the shell and the outer surface of the flange, having an inner annular anchorage portion abutting the inner surface of the flange, having a tapered tubular sleeve for the electrical conductor extending endwise from the shell around the opening aforesaid, and having an annular connector portion extending through the opening aforesaid and connecting the outer coating portion and the sleeve to the inner anchorage portion.

It is a further object of the present invention to provide a special tool comprising a mandrel, an expansible split ring, and an annular stop or abutment member for use in supporting the shell for dipping in liquid plastic to produce the aforesaid construction.

Other objects and features of the invention will become apparent as the description proceeds, especially when taken in conjunction with the accompanying drawings, wherein:

Figure 1 is a fragmentary longitudinal sectional view through the combined receptacle and plastic boot, and showing the tool in an operative position relative to the receptacle and boot.

Figure 2 is an enlarged fragmentary longitudinal sectional view through the finished product, with the tool omitted.

In the drawing the electrical receptacle A is a bulb receiving socket having a cylindrical shell 10 connected at its forward end to a short tube 12. The shell 10 and tube 12 are connected together by bending the adjacent end portion of one over a radially outwardly extending flange portion of the other to provide an annular abutment flange 14. The shell 10 is provided with a forma-

2

tion indicated at 16 for coaction with projections on the base of an electrical light bulb. Since these form no part of the present invention they are not illustrated or described in detail.

Adjacent its rear end the shell 10 is provided with an outwardly projecting annular open return bent portion 18 constituting an external bead for the shell and providing an inwardly opening annular channel. The outermost side of said return bent portion extends inwardly beyond the side walls of the cylindrical shell and provides an annular radially extending flange 20 that defines an opening 21 through which an electrical conductor may extend.

To complete the receptacle A and to provide the shell with the plastic boot, the shell 10 is supported on a tool comprising a mandrel B, an expansible split ring 25, and an annular stop or abutment member 26. As shown, the mandrel B has a body portion 22 shaped to fit rather closely within the shell 10 of the receptacle so as to prevent flow of liquid plastic material between the outer surface of the body portion 22 and the inner surface of the shell. The mandrel is also provided with an annular groove 24 which receives the expansible split ring 25. This split ring 25 is adapted to have a frictional grip on the inner surface of the shell 10 so as to support the receptacle on the mandrel. The annular stop or abutment member 26 is sleeved on the mandrel B and may be held in adjusted position thereon by any suitable means (not shown). Such annular stop or abutment member 26 encircles the tube 12 and is engageable with the abutment flange 14 to limit insertion of the mandrel into the shell 10. At its inner end, as seen in Figure 1, the body portion 22 of the mandrel is provided with a tapered extension 28 that extends through the opening 21 and is spaced radially inwardly from the edges thereof to permit liquid plastic material to flow inwardly of the shell.

The inner end of the body portion 22 of the mandrel projects laterally from the tapered extension 28 and constitutes an annular radial shoulder 30. The annular stop or abutment member 26 of the tool limits insertion of the mandrel in the shell 10 to a position in which the shoulder 30 is spaced substantially above the upper surface of the flange 20, to provide an annular space or chamber.

When the tool, with the receptacle in position thereon is moved downwardly into a liquid plastic material, the plastic material provides a coating 32 on the tapered extension 28 of the mandrel, a coating 34 on the lower surface of the flange 20, a coating 36 on the outer surface of the open return bent portion 18, and a coating 40 on the outer surface of the shell 10 to a height determined by the depth of insertion into the plastic material. At the same time, the inward spacing of the tapered extension 28 of the mandrel from the inner edge of the flange 20 permits the plastic material to flow around the tapered extension 28 into the annular space between the shoulder 30 of the mandrel and, the upper surface of the flange 20, and thence into the inwardly opening annular channel provided by the open return bent portion 18 to form a relatively thick annular anchorage portion 42. Preferably, the shoulder 30 is located so that the anchorage portion 42 has a thickness substantially greater, and preferably several times greater, than the coating portions 32, 34, 36 and 40. In addition, it will be observed that the plastic material forms an annular connector portion 44 extending through the opening 21, overlying the inner edge of the flange 20, and serving to connect the integral outer coating portions 32, 34, 36 and 40 respectively to the annular anchorage portion 42. This connector portion 44 serves the additional function of protecting the electrical conductor from en-

3

gement with the inner edge of the flange 20, and together with the tapered sleeve produced by the coating 32 when the mandrel is withdrawn, provides a completely insulated path for the electrical conductor into the interior of the receptacle.

The tapered sleeve portion produced by the coating 32 at its outer end is designed to engage tightly the insulation on the electrical conductor, and thus the plastic boot provides a perfect seal preventing entry of foreign material into the receptacle or bulb socket from its rear end.

The boot described above is unitary and is firmly united to the shell 10, particularly by the provision of the internal annular anchorage portion 42.

Many different plastic materials are suitable for the purpose but excellent results have been obtained when the plastic boot is formed by dipping in a vinyl plastic. This material is flexible and resilient and at the same time exhibits substantial strength so as to produce a rugged booted receptacle adapted for general use.

The drawings and the foregoing specification constitute a description of the improved booted electrical receptacle in such full, clear, concise and exact terms as to enable any person skilled in the art to practice the invention, the scope of which is indicated by the appended claim.

What I claim as my invention is:

An electrical receptacle comprising a tubular metallic shell having at one end thereof a laterally projecting open return bent annular flange providing an inwardly opening annular channel, the outermost side of said annular

4

channel projecting inwardly and providing an axial opening for an electrical conductor, and a plastic boot for said shell provided in alignment with said axial opening with an axially extending sleeve for said electrical conductor, said sleeve having an annular portion constituting an endwise extension thereof projecting through said axial opening and overlying the inner edge of said flange, said sleeve also having spaced portions projecting laterally from said annular portion, one of said spaced portions extending into and substantially filling said channel, the other of said spaced portions enveloping and disposed in surface-to-surface relation with exterior surfaces of said channel, said annular portion connecting said spaced laterally projecting portions aforesaid and protecting the electrical conductor from engagement with the inner edge of said flange.

#### References Cited in the file of this patent

##### UNITED STATES PATENTS

20	1,800,578	Webb	Apr. 14, 1931
	2,077,686	Gober	Apr. 20, 1937
	2,433,373	Krim	Dec. 30, 1947
	2,647,222	Nieset	July 28, 1953
25	2,683,287	Cochran et al.	July 13, 1954
	2,704,834	Heller	Mar. 22, 1955
	2,712,120	Cochran	June 28, 1955
	2,731,613	Heller	Jan. 17, 1956
	2,801,397	Longnecker	July 30, 1957