



US 20070186500A1

(19) **United States**

(12) **Patent Application Publication**
Quirk

(10) **Pub. No.: US 2007/0186500 A1**

(43) **Pub. Date: Aug. 16, 2007**

(54) **FLASHING**

(30) **Foreign Application Priority Data**

Dec. 9, 2003 (AU)..... 2003906832

(76) Inventor: **Peter Quirk, Bardon (AU)**

Publication Classification

Correspondence Address:

RATNERPRESTIA
P O BOX 980
VALLEY FORGE, PA 19482-0980 (US)

(51) **Int. Cl.**

E04H 12/00 (2006.01)

(52) **U.S. Cl.** **52/300**

(57) **ABSTRACT**

Flashing includes an elongate body for overlying a member, and legs extending for at least part of the body length and protruding from either side of the body. The flashing has a configuration prior to overlying the member whereby one or both legs is/are biased towards a respective member side when positioned thereat. The legs may be detachable from the body along a line of severance. In addition, wings can extend out from either side edge of the body to extend for at least part of the body length. One, some or all of the wings can be detachable from the body along a line of severance.

(21) Appl. No.: **10/582,074**

(22) PCT Filed: **Dec. 9, 2004**

(86) PCT No.: **PCT/AU04/01742**

§ 371(c)(1),
(2), (4) Date: **Mar. 16, 2007**

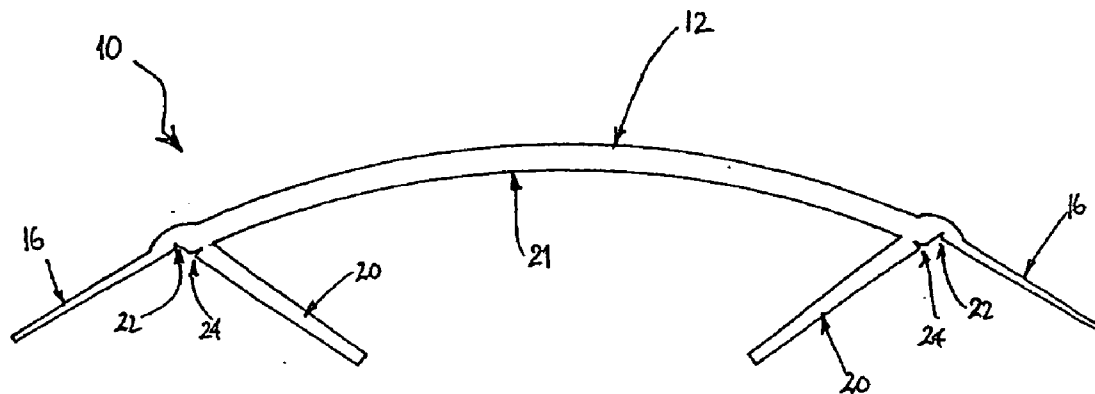

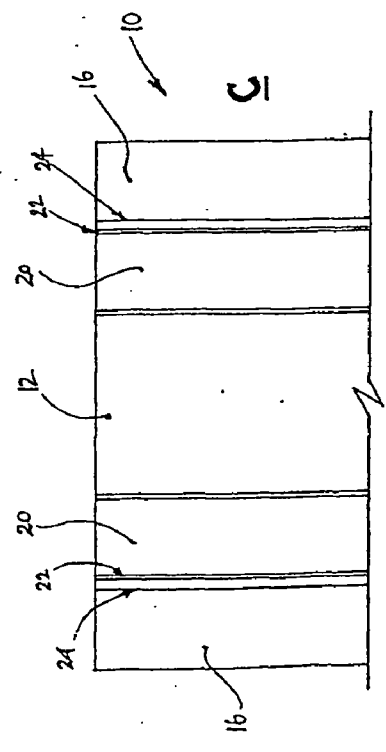
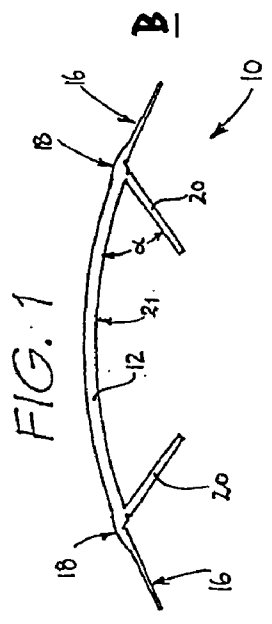
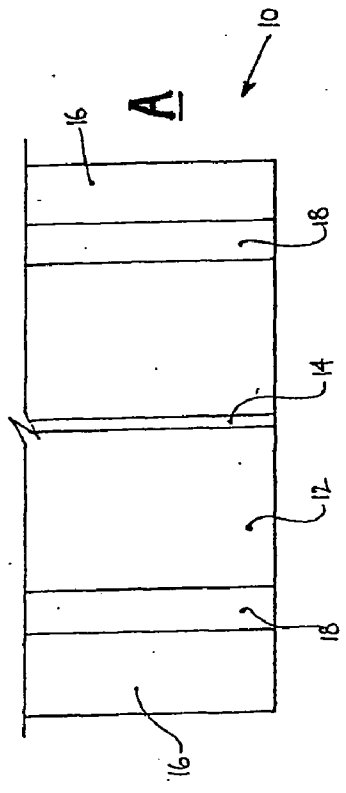
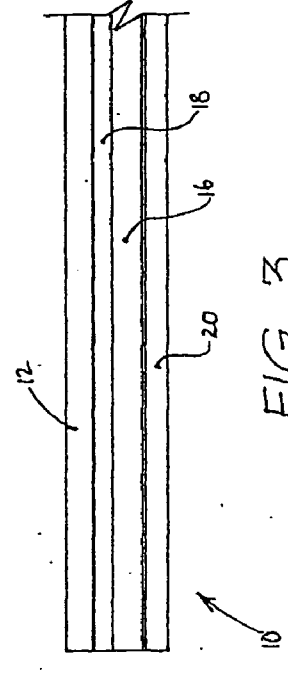
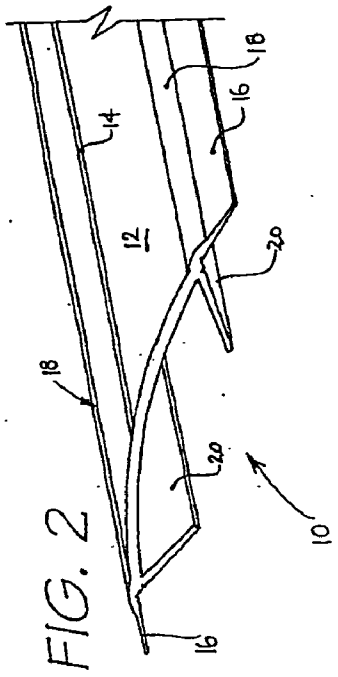

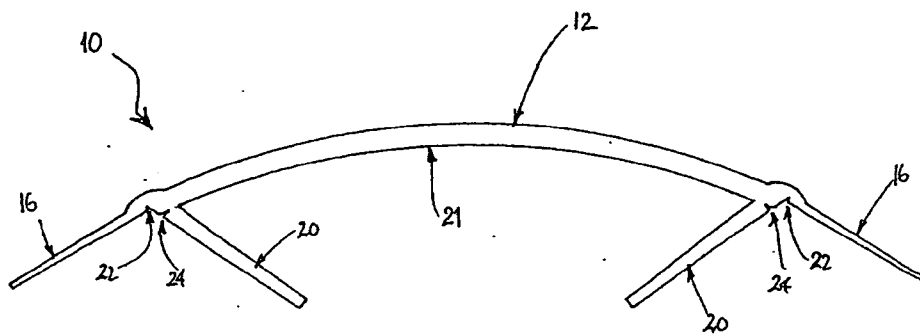

FIG. 4

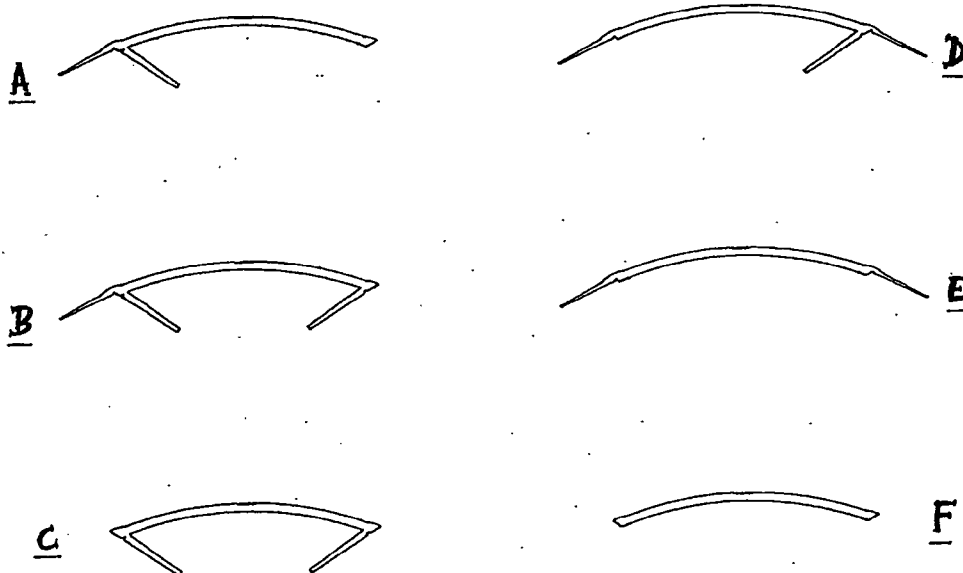
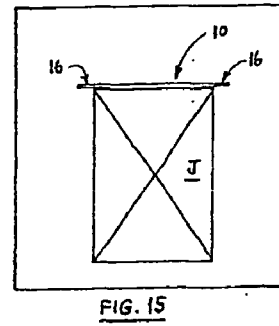
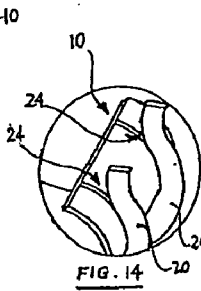
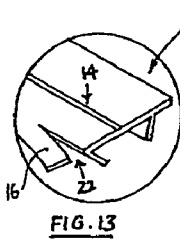
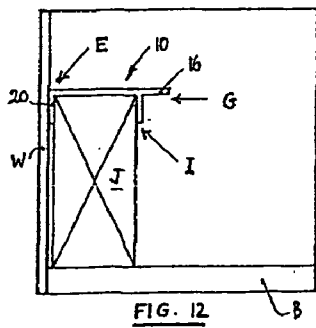
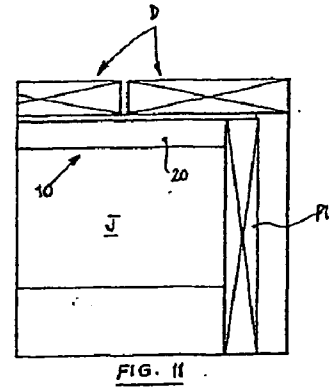
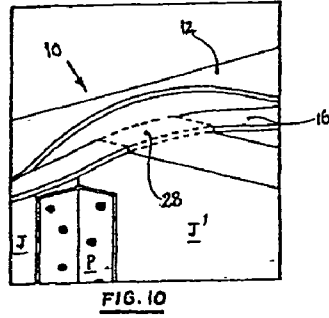
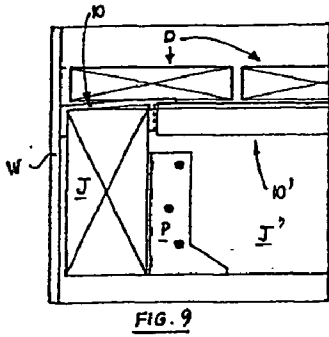
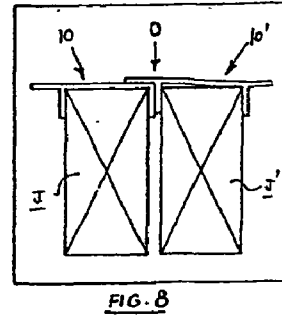
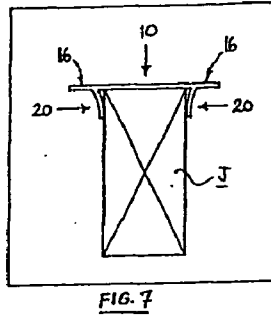
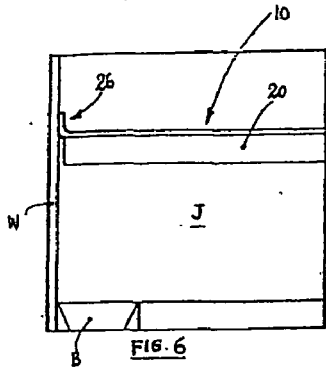

FIG. 5



FLASHING

TECHNICAL FIELD

[0001] Flashing is disclosed which finds particular use in the construction industry, primarily for covering members such as joists, beams, bearers, wall plates, rafters and the like.

BACKGROUND ART

[0002] Flashing is used in the construction industry to provide a barrier against the passage of moisture into and beyond joists, rafters, beams, bearers, wall plates and the like, especially where such members are formed from materials susceptible to moisture such as timber.

[0003] Known flashing includes metal strips or metal-containing sheets which are cut and positioned in relation to the member. It is also known to use adhesive tape in the place of metal flashing.

[0004] U.S. Pat. No. 5,148,644 discloses a covering strip of rubber or plastic. At column 2, lines 1&2 it is stated that the strip is dimensioned so that the distance between the side portions substantially corresponds to the width of a wooden member on which the strip is placed.

SUMMARY OF THE DISCLOSURE

[0005] In a first aspect there is provided flashing comprising an elongate body for overlying a member, and legs extending for at least part of the body length and protruding from either side of the body, the flashing having a configuration prior to overlying the member whereby one or both legs is/are biased towards a respective member side when positioned thereat.

[0006] Thus, the flashing can be provided with an in-built bias which enables it to better grip onto and/or locate on the member on which it is placed. This bias can be pre-configured within the flashing body to then be transferred to the legs when the flashing is placed on the member, and/or can be pre-configured within either one or both legs. In one form, both legs may have such bias.

[0007] In addition, whilst the legs may be spaced at approximately the width of a member (eg. the flashing can be supplied with leg spacings corresponding to one or more standard member widths), the legs may also have a spacing that is greater than or, in the case of an elastomeric flashing, slightly lesser than the member width and yet still be configured to grip onto the member.

[0008] In one form the body can be provided with eg. a contoured profile. For example, the legs may extend inwardly from a concave surface of the body. Then, when the flashing is located on the member, the body can assume a generally flat configuration. The contoured profile provides one means by which bias can be pre-configured within the flashing.

[0009] In one form the flashing is formed from an elastomeric material. Use of an elastomeric material provides for noise reduction (especially when used on metal members such as metal joists) and can provide for impact absorption between adjacent members (ie. between which the flashing is located). In addition, when nails or screws are driven through the flashing, the elastomeric properties enable the

elastomeric material to grip around the nails or screws, thereby preventing water, moisture, liquid and dust movement therepast. The use of an elastomeric material can also enhance the in-built bias of the or each leg.

[0010] The term “elastomeric” is intended to include a broad range of polymers having resiliency and/or shape memory, and includes natural and synthetic rubbers such as EPDM rubber, polymeric resins having flexibility and resiliency such as ABS resin and other butadiene and styrene polymers and co-polymers, nylons etc. EPDM rubber is particularly useful because it has excellent UV, ozone and chemical resistances, and is long-ageing. In addition, it is resistant to most paints, lacquers, oils, solvents, acids and cleaning agents.

[0011] The term “member” as used herein includes joists, 10 beams, bearers, wall plates, rafters, battens and the like.

[0012] In a second aspect there is provided flashing comprising an elongate body for overlying a member, and legs protruding from either side of the body and extending for at least part of the body length, wherein one, some or all of the legs are detachable from the body along a respective line of severance.

[0013] In a third aspect there is provided flashing comprising an elongate body for overlying a member, and wings extending laterally from either side of the body and extending for at least part of the body length, wherein one, some or all of the wings are detachable from the body along a respective line of severance.

[0014] By providing for leg and wing detachability, various flashing shapes can be created which can allow for accommodation of various other adjacent members in abutting or closely positioned relationships. For example, when all legs and wings are detached, the resultant flashing may simply comprise the elongate body, or when one of the legs and one of the adjacent wings are detached and the flashing is applied to a first member, an adjacent second member can be butted right up against the first member where that leg and wing have been removed, etc.

[0015] In one form the flashing comprises two legs extending for the entire length of the body on opposing sides thereof, although a plurality of discrete legs arranged along part or the entire length of the body on opposing sides thereof can also be provided.

[0016] In one embodiment, prior to positioning the flashing on the member, legs on opposing sides of the body project generally towards each other. In this regard the flashing may be extruded or moulded so that the legs in the finished configuration project generally towards each other and so that the flashing is manufactured with an in-built bias. Thus, when the legs are positioned on either side of the member, they are biased towards that respective side. This enables the flashing to grip onto the member, making it easier to use and tending to prevent its inadvertent removal. For example, when the flashing is used in an inverted or vertical configuration, the legs grip onto the member and prevent the flashing from dropping off the member.

[0017] In addition, by providing legs which extend for the entire length of the body on opposing sides thereof the flashing can prevent stain marks from promulgating down the side of the member to which the flashing is attached (eg.

resin stains, water stains etc that emanate from or occur on timber members, or from seepage from overlying, abutting or adjacent members etc).

[0018] In another embodiment the flashing further comprises wings extending laterally from the body beyond the legs (ie. the wings can be provided in addition to the legs). Again, the wings may extend for the entire length of the body on opposing sides thereof, although a plurality of discrete wings can be provided for part of or for the entire length of the body on opposing sides thereof. The wings enable the flashing to overlap adjacent members, and can also overlap adjacent flashing etc to provide for a more comprehensive barrier against moisture, dust, noise and the like.

[0019] A line of severance can also be provided along and adjacent to where each wing is attached to the body to enable wing detachment. In other words, a discrete or an entire length of the wing can be removed to enable positioning of the member in close proximity to other members and to enable the abutment of adjacent members etc.

[0020] The wings may have an elongate rectangular shape and can respectively be joined to the body along opposing elongate sides thereof. In a further variation, each wing can taper, from a relatively thicker section where it is connected to the body to a relatively thinner remote end (ie. the wing having a decreasing cross-sectional thickness out to its remote end). This tapering configuration can reduce any distortion between flashing heights in adjacent members where the wing overlaps adjacent flashing (eg. of an adjacent member). The wings can also be fastened directly or indirectly to an adjacent member (eg. by nailing, screwing, adhesive, etc).

[0021] In one embodiment a line of severance is provided along and adjacent to where each leg attaches to the body to enable all or any of the legs to be detached from the body as appropriate, in a similar manner to wing detachment. Again, detaching of one or more legs allows for close positioning or abutment of adjacent members etc.

[0022] The body may have an elongate rectangular shape so that it can be positioned along a corresponding rectangular face of a member (eg. an upper face of a joist, bearer etc). The legs can also have an elongate rectangular shape and be respectively joined to the body along opposing elongate sides thereof (eg. so that they can run along corresponding rectangular side faces of a member such as a joist). Each leg may also taper, from where it is connected to the body to a remote end, or can be provided with a constant thickness therethrough.

[0023] In a fourth aspect there is provided an arrangement between first and second members wherein flashing as defined in the first, second or third aspects is mounted to an in-use upper surface of each member such that the flashing of one member overlaps the flashing of another.

[0024] In the fourth aspect selected wing(s) and/or leg(s) of the flashing of each member can be removed to reduce or eliminate the degree of flashing overlap.

[0025] The arrangement may be defined as a joint (eg. a butt joint) between the first and second members.

BRIEF DESCRIPTION OF THE DRAWINGS

[0026] Notwithstanding any other forms which may fall within the scope of the flashing as defined in the Summary,

specific flashing embodiments will now be described, by way of example only, with reference to the accompanying drawings in which:

[0027] FIGS. 1A, 1B, 1C show respectively plan, end and underside plan views of an end section of a flashing embodiment;

[0028] FIG. 2 shows a perspective view of the flashing end section of FIG. 1;

[0029] FIG. 3 shows a side elevation of the flashing end section of FIG. 1;

[0030] FIG. 4 shows an enlarged end elevation similar to FIG. 1B and illustrating lines of severance in the flashing in greater detail;

[0031] FIGS. 5A-5F show end elevations of various flashing configurations in which parts of the flashing have been detached for different applications; and

[0032] FIGS. 6-15 show various in-use configurations of the flashing of FIGS. 1-5.

DETAILED DESCRIPTION OF SPECIFIC EMBODIMENTS

[0033] Referring firstly to FIGS. 1 to 3, a flashing embodiment 10 comprises an elongate body portion 12 having a centre line 14 formed (eg. indented or raised) or printed thereon to enable centring of the body portion on a member such as a joist or the like. The centre line 14 also provides a guide for accurate nailing/screwing of overlying members (eg. decking).

[0034] Projecting laterally from respective longitudinal sides of the body portion 12 are two wing portions 16. Each wing portion is attached to the body portion via a respective raised region 18, which supports flexure of the wing portion with respect to the body portion.

[0035] It will also be seen that each wing portion tapers in thickness from the raised region out to a free edge thereof. Thus, adjacent to its free edge, each wing portion is relatively thin, and this allows it to overlap adjacent flashing etc (as described below). In addition, each wing portion may extend for the entire length of the body portion, or may be provided as a series of discrete wing portions spaced along a respective longitudinal side of the body portion. As a further alternative, discrete wing portions can be cut, torn or severed from a larger length of wing portion in use, again depending on the application.

[0036] Extending downwardly from adjacent longitudinal sides of the body portion are two leg portions 20. Each leg portion is connected to the body portion adjacent to a respective raised region 18, and each leg portion subtends an acute angle α (FIG. 1B) with the body portion. Thus, prior to locating the flashing on a member, and as can be seen in FIG. 1B, the leg portions tend to generally point towards each other, which provides the flashing with a pre-application configuration that enables it to grip onto a member, as described below.

[0037] Alternatively, one of the legs may extend generally orthogonally from its connection to the body portion, and yet the other leg when subtending an acute angle can still provide the flashing with a pre-application configuration that enables it to grip onto a member.

[0038] Each leg portion can also slightly taper in decreasing thickness from the body portion out to a free edge thereof. This provides the leg portion with a greater degree of stiffness adjacent to the body portion and relatively less stiffness away from the body portion. This also assists with maintaining an in-built bias in the leg portion orientation to the position as depicted in FIG. 1B and 2.

[0039] Again, each leg portion can extend for a full length of the body portion, or can be provided as a series of spaced apart discrete leg portions along the length of the body portion. In addition, these discrete leg portions can be formed by severing, tearing or cutting sections of a leg portion from the remainder of the leg portion length.

[0040] As best shown in FIG. 1B and 4, the body 12 is provided with a contoured profile. The legs 20 extend inwardly from a concave surface 21 of the body. Then, when the flashing 10 is located on a member, the body 12 will assume a generally flat configuration (FIG. 7). However, the previously contoured body profile now provides a bias which is transferred to the legs 20 so that they grip onto respective member sides.

[0041] In an alternative arrangement the body 12 can be supplied in a generally flat configuration, with one or typically both legs 20 generally pointing to each other. Then, when the flashing 10 is located on a member, the bias is provided by the one or both legs, so that the legs then grip onto the respective member sides.

[0042] As best illustrated in FIG. 1C and 4, a line of severance 22 is provided where the wing portion 16 connects to raised region 18. This enables each wing portion to be partially or completely severed, cut or torn from the body portion (eg. as shown in FIGS. 5A, 5B, 5C, 5F and 13). Similarly, a line of severance 24 is provided where each leg portion connects to the body portion 12. Again, this allows each leg portion to be partially or completely severed, cut or torn from the body portion (as shown on FIGS. 5A, 5D, 5E, 5F and 14). In addition, the lines of severance 22,24 need not be at the connection points of the wing/leg portions to the body portion and, for some applications, could instead be located partway along the wing/leg portions.

[0043] Referring now to FIG. 5A to 5F, it will be seen that a number of different wing portion and leg portion detachment scenarios are possible. Each of these allows the flashing to be used in parallel or in various angular relationships with adjacent flashing on adjacent members and allows for various other positional arrangements of the flashing on a member to which the flashing is mounted.

[0044] Referring now to FIG. 6, flashing 10 in accordance with the present invention is shown positioned on a member in the form of a joist J, an end of which is butted to a wall W (which may also be a beam etc). The joist J also sits on top of a member in the form of bearer B. As can be seen, part of each of the leg portions 20 is cut or torn away, or removed, to define an end region 26 of the body portion 12. This end region together with the wing portions 16 lap upwardly along the wall W as shown.

[0045] This lapping provides a barrier to water, moisture, liquids, dust etc at the joint of joist J to wall W. The end region can also be sealed against the wall (eg. by nailing, screwing, adhesive etc). In addition, the wing portions 16 at

the end region overhang laterally either side of the joist to provide a covering effect to the joint.

[0046] As best shown in FIGS. 7 and 8, when the flashing 10 is mounted to a joist, the leg portions 20 are urged outwardly by respective sidewalls of the joist J. Because of a pre-configured internal bias in the flashing against such outward movement, the leg portions grip onto either side of the joist. This then enables placement onto the flashing of overlying members (eg. battens, decking etc) and fastening of these members to the joist with less likelihood of flashing displacement.

[0047] Referring specifically to FIG. 7, it will be seen how the flashing 10 covers and protects the top face of the joist J, with the wing portions overhanging the joist on either side to prevent moisture (eg. rain etc), fluid seepage and dust etc falling onto the top and sides of the joist. In addition, it will be seen how the leg portions 20 (biased outwardly by the respective joist side faces) grip on to the joist to hold the flashing firmly in place. If desired, adhesive can also be applied between the flashing and the joist.

[0048] When an overlying member (eg. decking, floorboards, panels etc) is positioned on top of the flashing, nails or screws can be driven through the flashing. Where the flashing is formed from elastomeric or deformable material, it tends to grip around the side of the nail or screw, thereby also preventing the passage of moisture, dust etc between the flashing and nails/screws and towards the joist. The flashing can thus act as a complete waterproof barrier and can prevent rotting, warping, etc of the joist. The flashing can also prevent moisture vaporisation between the joist and flashing which can otherwise lead to bubbling, buckling etc.

[0049] Referring now to FIG. 8, parallel joists, J and J' are shown. In this embodiment the left-side flashing 10 has one of its wing portions removed (in the manner as shown in FIG. 5B) enabling the adjacent right-side flashing 10' to overlap in the region shown by arrow O. As also shown in FIG. 8, the leg portions located between the adjacent joists can be compressed together when the flashing is formed from an elastomeric or deformable material.

[0050] Because the wing thickness tapers out to its remote edge, the thickness of the overlap also accordingly tapers. This means that, for any overlying member (eg. batten, floorboard etc) there is not an undue or overly uneven overlap to underlie that member in use. For elastomeric flashings, this more minimal degree of thickness of overlap may also be readily and easily compressed in use.

[0051] The overlapping of adjacent flashings further provides greater sealing against the passage of moisture, dust between the adjacent joists, which has many advantages. In addition, it provides for increased support for overlying members to enhance impact resistance, sound absorption, cushioning etc.

[0052] Referring now to FIG. 9, an arrangement for abutting perpendicular joists J and J' is depicted (ie. a so-called "butt" joint). In this arrangement, the joists are connected by a screw or nail plate P. The left-side joist J has a flashing 10 mounted thereto, similar to the flashing shape of 5B. The left-side flashing 10 has one of its wing portions removed to enable the left-side joist to be positioned in close facing relationship (or abutment) to a wall W. The flashing of FIG. 5A can also be employed in this regard.

[0053] The right-side joist J' employs a flashing 10' shaped similarly to that shown in FIG. 4. As can be seen, the left-side flashing has a wing portion that overlaps the right-side flashing to provide a moisture etc barrier at the intersection of the two joists. Decking members D can then be positioned over the two joists and fastened down onto them (eg. by screws or nails) which can extend through the respective flashings. The decking D can also compress against the overlapping wing portion of the left-side flashing. Again, because of its tapering thickness, the wing portion can be compressed by decking D so that adjacent decking members can be levelled as depicted.

[0054] FIG. 10 shows an arrangement of perpendicular joists J and J' similar to FIG. 9, but where a section 28 (shown in phantom) of the overlapping wing portion 16 has been cut, torn or detached along the line of severance 22 and also cut from a remainder of the wing portion 16 (eg. where no overlap of the wing portion is required or desired). This arrangement can be employed eg. where moisture etc ingress is not critical, such as in indoor applications.

[0055] Referring now to FIG. 11, an arrangement is depicted where the joist J abuts perpendicularly a plate member PL. Once again, sections of leg portions 20 have been removed adjacent to the plate PL to enable the body portion 12 and lateral wing portions 16 to lap over a top surface of the plate PL. Decking D can then be positioned on top of the joist at the intersection of the joist with the plate.

[0056] Referring now to FIG. 12, the close positioning of a joist J against a wall W whilst resting on a bearer B is depicted. The flashing can employ a shape similar to that shown in FIG. 5B. The location of one of the leg portions 20 between the joist and the wall prevents the ingress of moisture, dust etc at region E. The over-hanging of wing portions 16 prevents moisture, seepage etc running down the side of joist J, the moisture dropping off the flashing at region G. In addition, the provision of the right-side leg portion enables the joist to be painted, or coated with a sealer, and thereby prevents any overlying members (such as decking, floorboards etc) from being inadvertently coated with the paint, sealer etc. Thus, the bottom tip of the leg provides an edge I to enable paint "cutting-in".

[0057] As stated above, FIG. 13 shows the removal (eg. by cutting, tearing etc) at the line of severance 22 of one of the wing portions. FIG. 14 shows the removal at the lines of severance 24 of two of the leg portions.

[0058] Referring now to FIG. 15, a flashing 10 similar to that depicted in FIG. 5E is shown positioned on a joist J. In this application, both leg portions 20 of the flashing have been removed so that the flashing can be positioned on top of the joist and so that the wing portions 16 overhang either side of the joist. This arrangement can be employed where it is not necessary for the flashing to grip onto the joist (eg. where it is not critical that the flashing be in perfect alignment at a central position on top of the joist). Alternatively, to maintain a central alignment, the flashing can be adhesively fixed to the joist or can be nailed or screwed thereto, prior to then attaching overlying members to the joist.

[0059] Whilst in FIGS. 6-12 and 15 the flashing has been described with reference to its use on joists, it should be

appreciated that the flashing can be used with many different types of members including beams, bearers, rafters, battens, purlins, girts, uprights etc.

[0060] Whilst typically the flashing is formed from an elastomeric polymer, in some applications it may be formed from more rigid polymers or other materials. Thus, it can be extruded or moulded and supplied in easy to use rolls.

[0061] As stated above, the flashing provides a number of key features. These include:

[0062] The capacity of the flashing to cover and protect the upper surfaces of joists, beams and other members (especially timber joists and beams) to prevent rot, splitting, swelling, staining, discolouration, etc from moisture and other liquid passage, dust etc.

[0063] The in-built bias in the flashing which enables the leg portions to grip onto the side of a member, thus enabling the flashing to be used in a number of orientations, including inverted orientations.

[0064] Detachability/severability of the leg portions and wing portions of the flashing, which enable it to be used in a variety of different applications, some of which have been described above with reference to FIGS. 5-15.

[0065] The capacity of the flashing to grip onto nails, screws etc inserted therethrough, to waterproof and prevent moisture, dust and the passage of other matter between the flashing and the nail/screw.

[0066] The capacity of the flashing to compress to enable overlapping of adjacent flashings without affecting respective levels of overlying members (such as decking).

[0067] The impact and shock absorption properties of the flashing, together with noise resistance and minimisation (especially where the flashing is used with metal and other hard members, including metal decking for formwork etc).

[0068] The capacity of the flashing to prevent moisture and dust passage into and between the joints between members, and to cover or shroud members by providing an overhang on either side thereof (eg. provided by overhanging wing portions 16).

[0069] The capacity of the flashing to be formed into a number of different shapes using the lines of severance and also because it can be easily cut, torn and shaped.

[0070] Whilst the flashing has been described with reference to a number of preferred embodiments, it should be appreciated that the flashing can be embodied in many other forms.

1. Flashing comprising an elongate body for overlying a member, and legs extending for at least part of the body length and protruding from either side of the body, the flashing having a configuration prior to overlying the member whereby one or both legs is/are biased towards a respective member side when positioned thereat.

2. Flashing as claimed in claim 1 comprising two legs extending for the entire length of the body on opposing sides thereof.

3. Flashing as claimed in claim 1 wherein, prior to positioning the flashing on the member, the legs on opposing sides of the body project generally towards each other.

4. Flashing as claimed in claim 1 further comprising wings extending laterally from the body beyond the legs.

5. Flashing as claimed in claim 4 wherein the wings extend for the entire length of the body on opposing sides thereof.

6. Flashing as claimed in claims 4 wherein a line of severance is provided along and adjacent to where each wing is attached to the body to enable wing detachment.

7. Flashing as claimed in claim 4 wherein the wings have an elongate rectangular shape and are respectively joined to the body along opposing elongate sides thereof.

8. Flashing as claimed in claim 4 wherein each wing tapers, from a relatively thicker section where it is connected to the body to a relatively thinner remote end.

9. Flashing as claimed in claim 1 wherein a line of severance is provided along and adjacent to where each leg attaches to the body to enable leg detachment from the body.

10. Flashing as claimed in claim 1 wherein the body has an elongate rectangular shape.

11. Flashing as claimed in claim 1 wherein the legs have an elongate rectangular shape and are joined to the body along opposing elongate sides thereof.

12. Flashing as claimed in claim 1 wherein each leg tapers, from where it is connected to the body to a remote end, or has a constant thickness therethrough.

13. Flashing as claimed in claim 1 that is formed from an elastomeric material.

14. Flashing as claimed in claim 1 wherein the member is a joist, beam, bearer, wall plate, rafter or batten.

15. Flashing as claimed in claim 1 wherein the legs are spaced at approximately the width of the member.

16. Flashing as claimed in claim 1 wherein the body is provided with a contoured profile, with the legs extending

inwardly from a concave surface of the body, whereby the body assumes a generally flat configuration when the flashing is located on the member.

17. Flashing comprising an elongate body for overlying a member, and legs protruding from either side of the body and extending for at least part of the body length, wherein one, some or all of the legs are detachable from the body along a respective line of severance.

18. Flashing comprising an elongate body for overlying a member, and wings extending laterally from either side of the body and extending for at least part of the body length, wherein one, some or all of the wings are detachable from the body along a respective line of severance.

19. Flashing as claimed in claim 17 wherein the line of severance is provided along and adjacent to where each leg or wing is attached to the body.

20. Flashing as claimed in claim 18 wherein the line of severance is provided along and adjacent to where each leg or wing is attached to the body.

21. (canceled)

22. An arrangement between first and second members wherein flashing as claimed in claim 1 is mounted to an in-use upper surface of each member such that the flashing of one member overlaps the flashing of another.

23. An arrangement as claimed in claim 22 wherein selected wing(s) and/or leg(s) of the flashing of each member is removed to reduce or eliminate the degree of flashing overlap.

24. An arrangement as claimed in claim 22 that defines a joint between the first and second members.

25. An arrangement as claimed in claim 24 that defines a butt joint.

26. (canceled)

* * * * *