

July 2, 1968

G. S. GREMILLION

3,390,533

MACHINE FOR LAYING CABLE AND THE LIKE

Filed Oct. 1, 1964

3 Sheets-Sheet 1

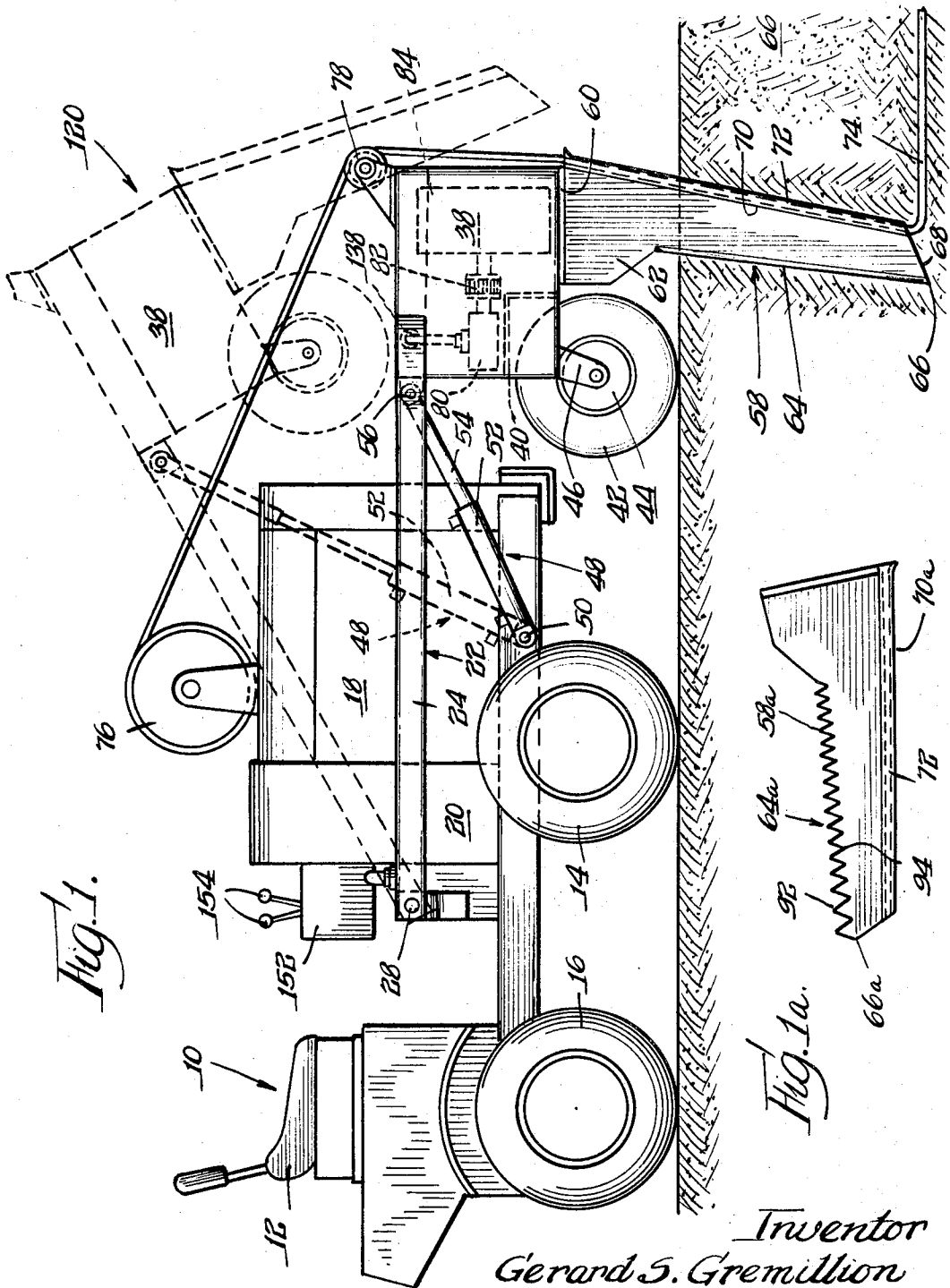

Fig. 1.

Fig. 1a.

Inventor
Gerard S. Gremillion
By: Olson, Truxel, Ulster & Bushnell
attys.

July 2, 1968

G. S. GREMILLION

3,390,533

MACHINE FOR LAYING CABLE AND THE LIKE

Filed Oct. 1, 1964

3 Sheets-Sheet 2

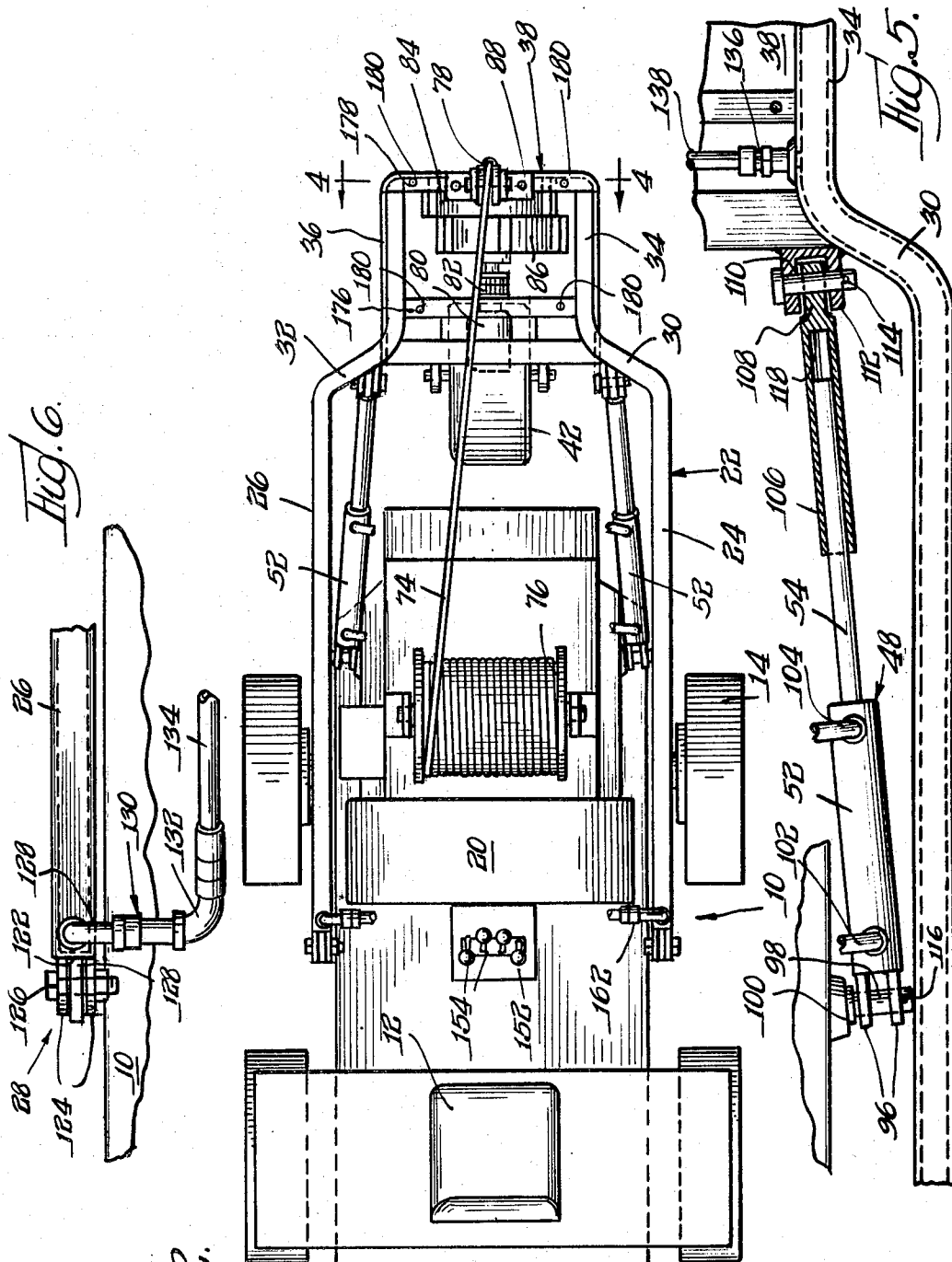

FIG. 2.

FIG. 5.

FIG. 6.

Inventor
Gerard S. Gremillion
By: Olson, Trepel, Wolter & Bushnell

July 2, 1968

G. S. GREMILLION

3,390,533

MACHINE FOR LAYING CABLE AND THE LIKE

Filed Oct. 1, 1964

3 Sheets-Sheet 3

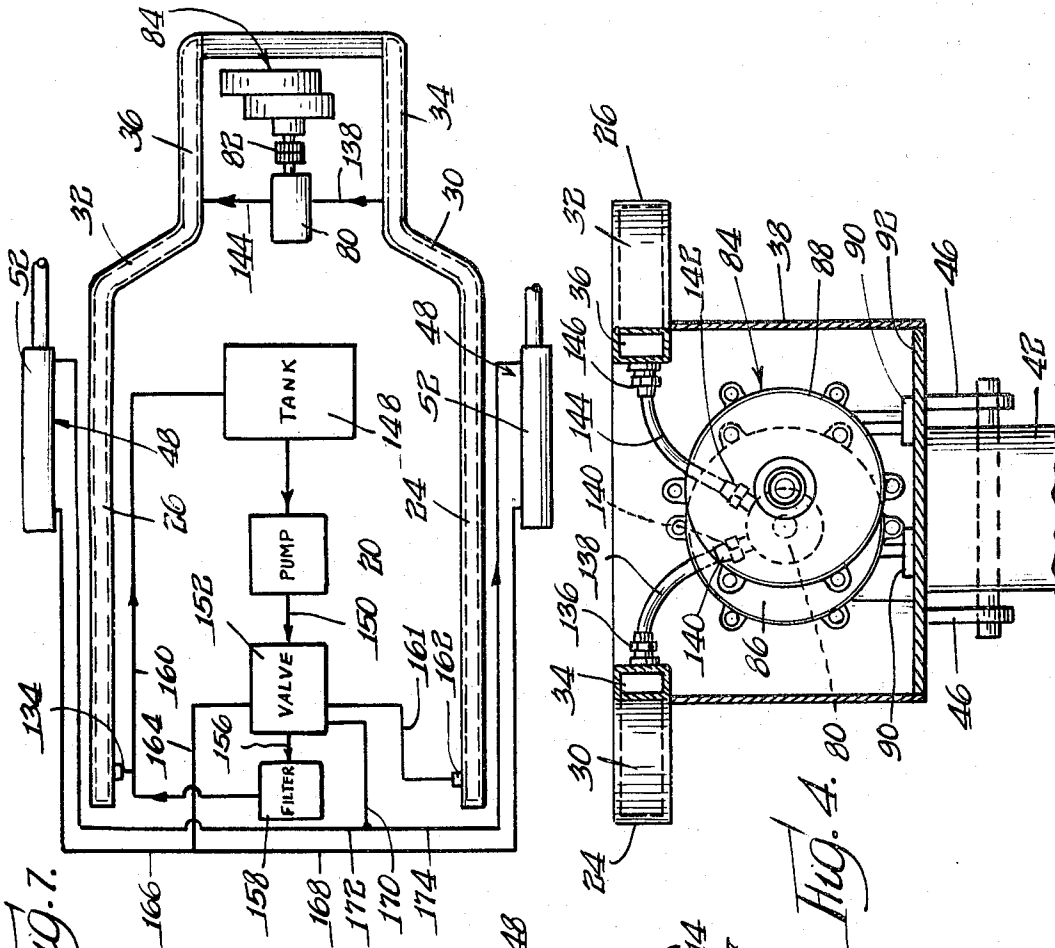

FIG. 7.

FIG. 4.

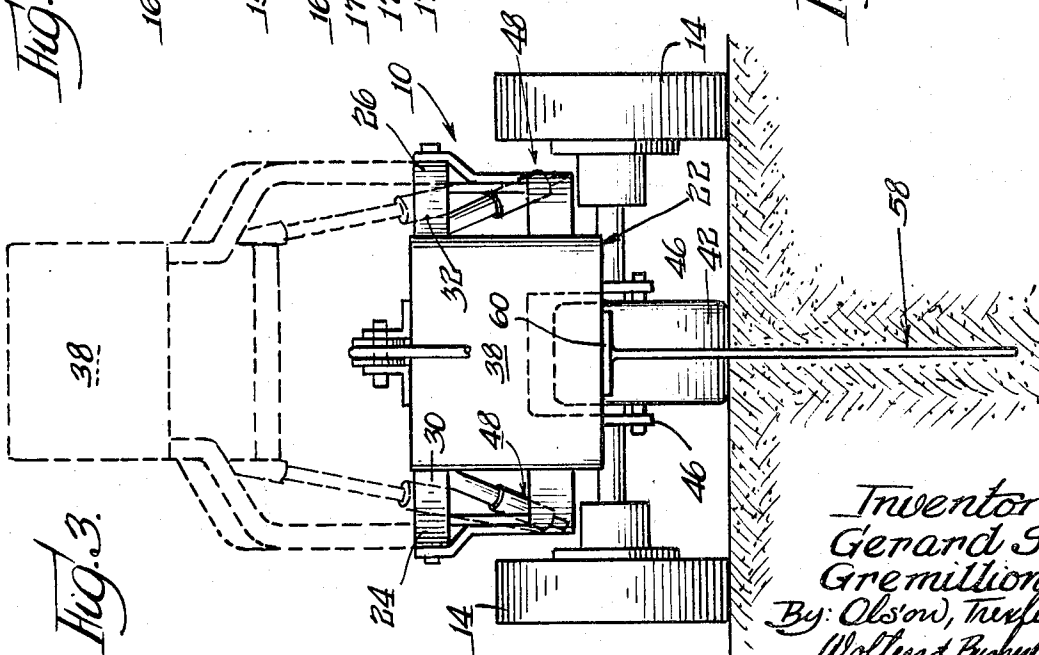

FIG. 3.

Inventor
Gerard S.
Gremillion
By: Olson, Tupper
Wollens & Bushnell

1

3,390,533

**MACHINE FOR LAYING CABLE
AND THE LIKE**

Gerard S. Gremillion, % Diggers, Inc., 3811 Lake St.,
Melrose Park, Ill. 60160
Filed Oct. 1, 1964, Ser. No. 400,850
4 Claims. (Cl. 61—72.6)

This invention relates to the art of burying cables, pipe, and the like.

A great many years ago, electric cable and pipe were buried by the hand digging of trenches in which the cable or pipe was laid, followed by hand refilling of the trenches and hand tamping. As the state of the art progressed, trenching machines were produced which would dig narrow trenches into which cable or pipe could be laid. Plows or blades on tractors or the like would then be used to refill the trenches.

Such burying of cable and pipe requires the removal and replacement of a rather large quantity of dirt for the size of the items laid down. It disturbs the soil to a considerable extent, and almost inevitably there is settling after precipitation has washed down and compacted the dirt. Rocky soil can render a conventional trenching machine inoperative, and conventional trenching machines will not work satisfactorily in sand or mud.

To overcome the drawbacks of digging trenches, either by hand or by machine, to lay cable and pipe, efforts have heretofore been directed toward the provision of plows. A plow having an elongated blade cuts a slit in the earth, and either subsequently or simultaneously lays the cable therein. Obviously, a rather considerable force is required to move a blade transversely through the earth, and it has been necessary to provide an anchor of some sort often at a distance from the area in which the cable or the like is being laid. A steel cable then is stretched between the implement carrying the plow blade and the anchor, and great tension force is applied to pull the plow blade through the earth. Typical drawbar pulls or tensional forces on the cable have been on the order of 8,000 to 30,000 pounds. Obviously, this requires considerable power and very strong parts, including the pulling cable. As will be appreciated, cables occasionally will break or come loose, and a cable with several thousand pounds drawbar stretch thereon becomes a lethal weapon upon release.

It is an object of the present invention to provide an improved machine for forming a slit in the earth or the like and simultaneously burying cable or pipe.

More particularly, it is an object of this invention to provide such a machine requiring relatively little power and extremely low drawbar force.

Yet another object of the present invention is to provide a machine for forming a slit in the earth or the like and simultaneously laying cable or pipe which will operate through substantially any type of soil and which is not stalled by rocks and other hidden obstacles.

Still another object of the present invention is to provide an earth slitting and cable or pipe laying machine comprising mainly standard parts including a small tractor of low horsepower.

Yet another object of the invention is to provide an earth slitting machine for laying cable and the like incorporating hydraulic actuation with improved means for maintaining the hydraulic fluid at relatively low temperature.

Specifically, it is an object of this invention to provide an earth slitting and cable or the like laying machine using an up and down shaking motion on the slitting blade.

In accordance with the present invention, a small tractor of conventional design is provided with a boom carrying a box and a blade. The box incorporates an eccentric weight shaker device of known design for effecting longi-

2

tudinal vibration of the blade. The shaker device in a preferred example of the invention is hydraulically driven. Upon lowering of the boom, the shaking of the blade longitudinally of itself causes the blade to cut into the earth.

After the blade has reached the proper depths, the tractor is moved transversely of the blade, and the longitudinal shaking motion of the blade causes it to cut through the earth as the tractor moves. Preferably the blade is provided with a cable laying tube so that the cable passes down along the blade, and is deposited in the bottom of the slit formed by the blade. When a rock is encountered by the blade, it simply rises to the surface, or moves to one side relative to the blade.

Further details of construction and principles of operation, as well as additional objects and advantages will be apparent from the following description when taken in connection with the accompanying drawings wherein;

FIG. 1 is a side view of a trenching and cable laying machine constructed in accordance with the present invention;

FIG. 1a is a side view of a modified trenching blade, tipped 90° from its operating position;

FIG. 2 is a top view thereof;

FIG. 3 is a front view;

FIG. 4 is a generally vertical sectional view taken along the line 4—4 in FIG. 2;

FIG. 5 is an enlarged view showing details of a portion of FIG. 6;

FIG. 6 is another enlarged view showing certain details; and

FIG. 7 is a hydraulic circuit for the invention.

Referring now in greater particularity to the drawings, and first to FIGS. 1, 2 and 3, the invention will be seen to include a small tractor 10 of a type readily available in commerce, including a driver's seat 12, a pair of front wheels 14, a pair of rear wheels 16, and an internal combustion engine 18. The precise details of the tractor are relatively unimportant, and in the specific example the tractor is one with a four wheel drive, wherein a plurality of levers (not shown) is provided for controlling the drive power and brakes to steer the tractor.

To the tractor there is added an additional hydraulic unit, comprising a pump and reservoir indicated rather generally at 20, and driven by the tractor engine. This is in addition to the usual hydraulic pump connected to the tractor engine, as more is needed than the usual pump to control the lifting of various implements is capable of providing. A boom 22 comprising a right arm 24 and a left arm 26 is pivoted on suitable fixed pivots 28 on the tractor substantially amidships thereof. The arms are of hollow or tubular construction for conveying hydraulic fluid, as hereinafter will be set forth, and are parallel throughout the greater portions of their extents, but are angled in at 30 and 32 adjacent their front ends, again continuing in parallelism at 34 and 36, and supporting between the front parallel portions 34 and 36 a rectangular box 38 which may be open at the top.

The lower rear corner of the box 38 is recessed at 40 to accommodate a pneumatic tire 42 on a wheel 44 pivotally mounted between a pair of depending arms or brackets 46 on the underside of box 38. As will be brought out hereinafter, the tire 42 must not only support the weight of the box 38, boom 22 and associated parts, but it is subject to a rather considerable vertical shaking force to which it must yield. In order to provide the requisite yieldability, and yet to provide support, the tire is of the type commonly used on golf carts which are designed to run on the fairways of golf courses without leaving any mark. In other words, it is quite wide, has a relatively flat tread, and is operated at rather low pressure.

Relatively adjacent the front of the tractor a pair of elevating hydraulic actuators 48 is mounted. These actuators, one on each side of the tractor, are pivoted at their rear ends at 50 to the frame of the tractor, and comprise hydraulic hoist cylinders 52 with the usual pistons therein, and with connecting rods 54 extending therefrom to pivotal mounts 56 at the upper rear portion of the box 38. Further details on this structure will be set forth hereinafter, but it will be understood that the actuators 48 are extensible from the solid line position of FIG. 1 to the dashed line position of FIG. 1 to raise the box 38 and associated parts from the solid line position which it occupies for trenching to the raised position shown in dashed lines for travelling.

Immediately forward of the wheel 44 and tire 42 on the underside of the box 38 there is mounted a trenching or slitting blade 58. The blade is provided at its upper end with a horizontal base 60 which is detachably bolted by means of bolts (not shown) to the bottom or floor of the box 38, which will be understood as comprising a heavy steel plate. Nuts may be provided on the inside of the plate, or the plate may have tapped apertures, or threaded studs may extend from the plate for receipt in holes in the blade base 60 with nuts to be turned down on the ends thereof. Such threaded studs comprise conventional construction, and details thereon need not be set forth. The blade is provided along its rear edge and immediately adjacent the tire 42 with a reinforcing gusset 62. From this point downwards, the rear edge of the blade 64 angles slightly to the left, proceeding down from the gusset 62, and comprises a sharpened cutting edge. Thus, with the tractor backed up in operation, the cutting edge 64 angles in beneath the earth 66 or the like, whereby to resist inadvertent rising up.

The cutting edge 64 proceeds to a sharp point 66, and the blade then tapers up at 68 to the trailing edge 70. As will be seen, the blade increases in thickness from the bottom toward the top for structural strength, the blade being made of hardened tool steel. A cable tube 72 is secured along the trailing edge 70 of the blade, and a flexible cable 74 is dispensed through this tube and out the bottom thereof adjacent the bottom edge 68 of the blade, to be buried beneath the earth. The cable is supplied from a reel such as indicated at 76 on top of the tractor, and over a pulley 78 to the top of the cable tube 72. As will be understood, the reel 76 preferably is of the type provided with a friction brake or some other rotation retarding means to prevent the reel from over-running and spewing forth loose cable.

Mounted within the box 38 (see also FIG. 4) is a hydraulic motor 80 connected by a suitable drive connection 82 to a shaker unit 84. The shaker unit 84 includes two relatively off-set housing portions 86 and 88 in each of which there is mounted an eccentric weight. The two weights counter-rotate and are driven in synchronism from a common gear drive in such manner that they will cause the shaker unit 84 to shake up and down with great force with a linear motion. The shaker unit has feet or flanges 90 by means of which it is mounted to the base plate 92 of the box 38, and thereby the box and the blade 58 are vibrated up and down with great force, the tire 42 alternately flattening and perhaps bouncing off the ground.

Details on the shaker unit need not be set forth, since said units are available commercially. One satisfactory shaker unit is that known as the "Ajax-Shaler Shaker" made by Ajax Flexible Coupling Co., Inc. of Westfield, N.Y. U.S. patents directed to this device include 1,999,213, 2,059,754, 2,097,347 and 2,178,813.

Before returning to some of the hydraulic features of the apparatus, it will be profitable to consider a modified form of trenching blade as shown in FIG. 1a. The blade has been tipped 90° from its normal operating position in this figure in order to fit on the page without reducing the scale. The trenching blade 58a is similar to the blade 50 heretofore shown and described, and similar numerals

are utilized with the addition of the suffix *a* to avoid duplication of description. The significant difference is that the cutting edge 64a of the blade, instead of being a sharpened, knife-like edge as the edge 64 in the previous form of the blade, comprises a series of saw teeth 92. The saw teeth are tapered from the root line 94 both in profile, as shown, and in cross section. A significant feature to be observed is that the teeth adjacent the tip 66a of the blade are larger and have deeper notches between them than the teeth toward the upper end of the trenching blade.

In most instances, the shapened edge 64 of the blade 58 works quite satisfactorily. However, in instances where the soil is known to contain many roots, the blade 58a of FIG. 1a is to be preferred, since the teeth 92 cut rapidly through the roots. It will be appreciated that roots near the surface are inclined to be rather small, whereas deeper roots are generally larger. It is for this reason that the teeth 92 are largest near the greatest depth to which the blade cuts, and become progressively smaller toward the surface. Substitution of one blade for another is a simple bolt-on job, as will be understood.

Reference should now be had to FIG. 5 for a fuller understanding of the mechanism for lifting the shaker portion of the apparatus. Reference heretofore has been made to the hoist or lifting device (or lifting devices, considering that they are duplicated on opposite sides of the apparatus). The cylinder 52, heretofore referred to, is provided at its rear or lower end with a clevis 96 having a transverse bore through the ears thereof receiving a stud 98 mounted on a box 100 welded to the side of the tractor. As will be seen, the stud 98 is not at right angles to the side of the tractor, but is tilted somewhat forwards, since the lifting device 48 angles in. The cylinder 48 is shown as a double acting cylinder, having hose connections 102 and 104 thereto. It will be appreciated that the shaking mechanism is lowered primarily by gravity and cuts into the earth by shaking action, and that a single acting cylinder therefore would suffice. However, the double acting cylinder effects speedier operation and may in some instances be superior for other reasons as well.

The piston rod 54 is received in a sleeve 106 having a flattened, solid end 108 pivoted on a stud 110 passing through the ears of a clevis 112 welded or otherwise suitably secured to the rear vertical wall of the box 38. As will be appreciated, this clevis is angled somewhat to be lined up with the lifting mechanism 48. The stud 110 is apertured at its free end for receipt of a cotter pin 114, and the stud 96 has a similar provision at 116. A stop 118 is provided within the sleeve 106 adjacent the flattened solid end 108 to limit penetration of the piston rod 54.

When the box 38 and attendant parts are lifted by the lifting mechanisms 48, the piston rods 54 push against the stops 118. However, as the box is lowered with the blade 58 cutting into the earth, the up and down vibration causes the piston rod 54 and sleeve 106 to pull apart, somewhat as shown in FIG. 5, with a continuous sliding or telescoping action taking place between the piston rod 54 and sleeve 106 as the box and attendant parts shake up and down. It will be appreciated that the arms 24 and 26 move up and down about their pivots at this time, and that the slip connection between the piston rods 54 and sleeve 106 prevents all of the shaking motion from being transmitted to the tractor, thereby serving substantially as a flexible mount for the shaking mechanism. Such shaking of the tractor would disadvantageously affect the service life of the tractor, and would be most discomforting to the operator.

The side arms 24 and 26 of the boom 22 for lifting the shaking mechanism are made of hollow steel tubing, three inches high and two inches wide. The shaking mechanism, hereinafter generically identified by the numeral 120 for the sake of convenience, is secured to the forward end of the boom by welding the inwardly offset portions 34 of

the arms to the sides of the box 38. Plugs are welded to the forward ends of the tubular arms.

Each of the arms 24 and 26 is also plugged at the back, and reference should be had to FIG. 6 for a showing of the construction relative to the arm 26. The plug comprises a transverse member 122 welded across the end of the tube, and has a clevis 124 at the rear end thereof. A transverse pin or stud 126 passes through this clevis, and also through an ear 128 upstanding from the frame of the tractor 10. The stud is shown as one which is threaded at the end and has a nut thereon, although it will be understood that a cotter pin or other holding means could be used. The arm 26 thereby is pivotally mounted from the frame of the tractor by means of the foregoing combination, comprising the previously mentioned pivot 28.

A hydraulic tube 128 is secured to and is in fluid communication with the arm 26 near the rear end thereof, extending generally vertically up, and then horizontally in. A snap-together hydraulic fitting 130 of known design connects this tube 128 to another hydraulic tube or elbow 132 leading to a hose 134 leading to a valved source of hydraulic fluid under pressure, as will be set forth hereinafter in connection with the hydraulic circuit. In a specific example of the invention, the arm 26 and hose 134 etc., comprise a return line, while the corresponding hose (not yet disclosed) and arm 24 comprise a supply line for the hydraulic motor 80.

At the front ends of the arms, and referring specifically to FIGS. 1, 4 and 5, hydraulic connections are made to the motor 80. Specifically, a coupling 136 is provided on the forward inner portion of the arm 34 leading to a hose 138 to the hydraulic motor 80, being connected thereto by a hydraulic coupling or fitting 140. Similarly, an outlet hydraulic coupling or fitting 142 from the motor 80 is connected by a hose 144 to a hydraulic fitting or coupling 146 connected to the forward portion 36 of the arm 26. By means of the construction just disclosed, hydraulic fluid under pressure is circulated to and from the hydraulic motor 80. As will be appreciated, the area of the flow path through the arms 24 and 26 is much greater than that through the various hydraulic fittings and hoses, whereby the flow velocity through these arms is relatively low. Furthermore, the substantially flat sides of these arms and the metallic construction thereof provide for efficient heat radiation. As a result, the hydraulic fluid circulated to and from the motor is kept at a reasonably low operating temperature. Indeed, after an extended period of operation, one can rest a hand comfortably on one of the arms 24, 26. Since a boom is necessary in an event, it has been possible to keep the hydraulic fluid at a desirably low operating temperature without the addition of any extra part or parts.

A hydraulic circuit forming a part of the present invention is shown in FIG. 7. As will be apparent, there is a reservoir or tank 148 for hydraulic fluid. From this, fluid is supplied to the pump 20 driven by the tractor engine. A line 150 leads from the pump to a valve 152 which may be seen in FIGS. 1 and 2 immediately forward of the operator's seat, and having a plurality of hand levers 154 (FIGS. 1 and 2) thereon for actuating the various valve connections. A bypass or circulating line 156 passes to a filter 158, and then on at 160 back to the tank 148.

The valve also is connected through a hydraulic line 161 and through a fitting 162 (see also FIG. 2) to the arm 24. As noted heretofore, hydraulic fluid passes through this arm, and also through the line or hose 138 to the hydraulic motor 80. From the motor, the fluid passes through the line or hose 144 back to the arm 26, and thence through the line or hose 134 to the bypass line 160 for return to the tank. As will be understood, one of the valve handles 154 controls the flow of fluid through the line 160 so that the motor 80 may be operated or not, as may be desired. The arm 24 (and

also the arm 26) heretofore has been disclosed as being two by three inches and substantially rectangular in cross section. By way of other dimensions that have proved satisfactory, the line 160 is a circular cross section line of one half inch diameter, as is the line 138. To avoid building up of back pressure, the line or hose 134 is three quarters inch in diameter, as are the lines 134 and 160.

Through another valve controlled by one of the handles 154, fluid passes to a line 164 branching at 166 and 168 to the hydraulic actuating cylinders 52. Fluid will return to the valve through the same line from the cylinders when pressure is released, and then through the bypass line 156 to the filter 158 and through the return line 160 to the tank 148. Since the cylinders 52 have been shown as double acting, there is also a second valved line 170 branching at 172 and 174 leading to the opposite ends of the cylinders 52. Preferably all of the lifting lines, i.e. the lines 164, 166, 168, 170, 172 and 174 are quarter inch diameter lines.

In order to use the apparatus of the present invention, the tractor 10 is driven in conventional fashion and is positioned at a point at which it is desired to start burying cable. The tractor is oriented such that it can back in the direction in which it is desired to lay the cable. The proper valve handle 154 is operated to start the hydraulic motor 80 in operation, either before or after the proper valve handle is operated to lower the boom or arms 24 and 26, whereby to bring the point 66 of the blade 58 into engagement with the ground. The entire shaking mechanism or assembly 120 thereupon shakes up and down with great force, typically with an amplitude of about one half inch and at 450 to 850 r.p.m. A maximum thrust of about 2500 pounds is developed, and the tractor is through its normal drive mechanism backed up.

The tire 42 determines the maximum depth of penetration, when taken in connection with the length of the blade 58, which of course is replaceable. For burying a cable eighteen inches deep, approximately twenty feet per minute of cable can be laid. At twenty-four inch depth, approximately eight feet per minute can be laid. The blade cuts through most obstructions, and has even been found to break or cut its way through scrap pieces of concrete in filled ground. If a rock is engaged which does not break up under the force of the blade, it has been found either to rise to the top of the earth or to move to one side relative to the blade.

After the cable has been laid, there is no pile up of earth in the vicinity, but only a line of broken ground. The tractor then is driven with either the right wheels or the left wheels on this line to compact it back to its normal condition, obviously with the shaker mechanism raised to carrying position.

Although no cover has been shown for the box 38, it will be appreciated that such a cover may in some instances be desirable, as in operation in inclement weather or in dusty areas, or otherwise. To this end, a horizontal cross member 176 is provided adjacent the rear of the box 38, and a similar horizontal cross member is provided at the front thereof at 178, both being drilled and tapped as at 180 to receive mounting bolts for a cover.

Instead of running cable down through the tube 22, cable or pipe can be affixed to the bottom end of the blade and pulled through the earth from a starting hole or other excavation.

It will be understood that the specific example of the invention as herein set forth is capable of modification, and that such modifications coming within the abilities of one skilled in the art form a part of the present invention, insofar as they fall within the spirit and scope of the appended claims.

The invention is claimed as follows:

1. Apparatus for laying an elongated member such as cable and the like comprising a vehicle, means for moving said vehicle along the ground, support means, means

mounting said support means from said vehicle for up-and-down movement relative to said vehicle, an elongated blade mounted on said support means and depending therefrom at least as far as the depth at which an elongated member, cable or the like is to be laid, elongated member positioning means on said blade adjacent the lower end thereof, shaker means connected to said support and said blade for shaking said blade up and down to penetrate earth and the like as said vehicle moves therealong, and resilient means on said support means resiliently limiting the depth of penetration of said blade, said resilient means including a pneumatic tire, a wheel on which said tire is mounted, said wheel having a substantially horizontal axle which is fixed in vertical relation to said blade.

2. Apparatus for laying an elongated member such as cable and the like comprising a vehicle, means for moving said vehicle along the ground, motor means operatively connected to said moving means for driving said moving means, support means, means mounting said support means from said vehicle for up-and-down movement relative to said vehicle, power means acting between said vehicle and said support means for moving said support means, an elongated blade rigid with said support means and extending down therefrom at least as far as the depth at which an elongated member such as cable or the like is to be laid, elongated member positioning means on said blade adjacent the lower end thereof, and counterrotating eccentric weight shaker means connected to said support means for shaking said support means and said blade up-and-down to penetrate earth and the like as said vehicle moves therealong, said shaker means including a pair of eccentric weights interconnected to rotate in respectively opposite directions synchronized so that the respective centers of mass of said weights move opposite to one another horizontally and move up simultaneously and down simultaneously to afford a substantially linear up and down movement substantially devoid of lateral movement, and power means operatively connected to said shaker means for counter-rotation thereof.

3. Apparatus for laying an elongated member such as cable and the like comprising a vehicle, ground-engaging means for moving said vehicle along the ground, motor means operatively connected to said moving means for driving said moving means, support means, means mounting said support means from said vehicle for up-and-down movement relative to said vehicle, power means acting between said vehicle and said support means for moving said support means, a substantially straight up-and-down elongated blade rigid with and carried by said support means and extending down therefrom at least as far as the depth at which an elongated member such as cable or the like is to be laid and substantially longer in vertical dimension than in horizontal dimension, elongated member positioning means on said blade adjacent the lower end thereof, counter-rotating eccentric weight shaker

means connected to said support means for shaking said support means and said blade up-and-down to penetrate earth and the like as said vehicle moves therealong, said shaker means including a pair of eccentric weights interconnected to rotate in respectively opposite directions synchronized so that the respective centers of mass of said weights move opposite to one another horizontally and move up simultaneously and down simultaneously to afford a substantially linear up and down movement substantially devoid of lateral movement, and power means operatively connected to said shaker means for counter-rotation thereof.

4. Apparatus for laying an elongated member such as cable and the like comprising a vehicle, ground-engaging means for moving said vehicle along the ground, motor means operatively connected to said moving means for driving said moving means, support means, means mounting said support means from said vehicle for up-and-down movement relative to said vehicle, power means acting between said vehicle and said support means for moving said support means, a substantially straight up and down elongated blade rigid with and carried by said support means and extending down therefrom at least as far as the depth at which an elongated member such as cable or the like is to be laid and substantially longer in vertical dimension than in horizontal dimension, said blade having adjacent its lower end a fore-and-aft dimension no greater than a corresponding fore-and-aft dimension adjacent its upper end, elongated member positioning means on said blade adjacent the lower end thereof, counter-rotating eccentric weight shaker means connected to said support means for shaking said support means and said blade up-and-down to penetrate earth and the like as said vehicle moves therealong, power means operatively connected to said shaker means for counter-rotation thereof, a wheel having a substantially horizontal axle which is fixed in vertical relation to said blade, and a pneumatic tire mounted on said wheel, said pneumatic tire engaging the ground and resiliently limiting the depth of penetration of said blade.

References Cited

UNITED STATES PATENTS

338,678	3/1886	Sullivant	61-725
2,632,265	3/1953	Ryan	61-72.6 X
2,663,515	12/1953	Kinsinger	61-72.6 X
2,702,502	2/1955	Rogneby	172-118 X
3,103,250	9/1963	Lamb	61-72.6
3,140,745	8/1964	Hinkle et al.	61-72.6
3,211,236	10/1965	Patton	172-40

FOREIGN PATENTS

674,669	5/1929	France.
629,544	5/1936	Germany.

EARL J. WITMER, *Primary Examiner.*