

(19)  
(12)

(KR)  
(B1)

(51) 。 Int. Cl.7  
E01D 11/00

(45)  
(11)  
(24)

2004 03 10  
10-0422298  
2004 02 27

(21) 10-2001-0020799  
(22) 2001 04 18

(65)  
(43)

10-2002-0080931  
2002 10 26

(73) 1579-6

(72) 1579-6

(74)  
:

(54)

( ) 가

가 , 가 , 가 ,

( ) 가 가

2a

1 ( )  
2a \_\_\_\_\_ 2c

3a 3b  
4a 4g



가

가

가

가

가

가

가

가

가

가

가

가

(beam)

가

가 가

가

가

가

가

가

가

2 8

(strand)

$$\langle \frac{1}{2a} 1(\ ) \rangle$$

(103)

가

(10

(104) . (W)

(102)

2a (102) (100) 가 . 가 2c

(109) 가 가 2c (106) ,

( )

(D) (105)

2a 가 ,

(D)

(105) 2b 2a

(105) 가 ,

(107) 3 3a

가 가

가 (girder)

(108) 3b

4 2 1 3 , 4a (110) 가 2 ,

3 3 (102) (111)

2 가 ,

가 3 2

가 가 4c ( 4b

, 2 , 4d

) 1 4e 4a 4b 2 ( 4

) 1 4f (101) , (104)

가 1 (111) 4e 4f 4a 4d 가 , 2

가 4a 4f 4a 4f 4a 4d 가 , 2

, 2 4a 4f (111) 가 ,

) 1 (101) 4g , (102) (112)

(105) , 1 ,

가 가 ,

(112)

(109)

1

1

가

가

가

가

가

가

가

가

가

가

가

가

가

< 2( ) >

5a  
(204)

(203)

5b  
(201)

(202)

(200)가

가

가

가

( .)

2

< 3( ) >

6

(303)

(shell)

6

(301)

(306)

(306)

(302)

(306)

가 (304)

(305)

(300)

가

가

( )

가

가

3

< 4( ) >

7

가

가

가

가

가

가

가

가

7a

(403)

(402) 가 (404) , (401) , (405) 가  
 , 7b 가 , 7a 가  
 4  
 가  
 )  
 (100,200,300,400) , ( )  
 가 (500,600) 8  
 8a (503) (501), (500, ) (502)  
 가  
 ( 가 가 가 )  
 8b (601) , (602) (600, \_\_\_\_\_ )  
 가 가 가 가 가  
 가 가 가 가 가  
 가 가 가 가 가  
 가 가 가 가 가  
 가 가 가 가 가  
 ( \_\_\_\_\_ )

(57)

1.

(104) ;

01) (D) ; (104) (103) (1  
 (101) ; (102)  
 ; , (102) ; (105) (101) ,  
 (108) ;

**2.**

;  
 ; (103) (101) (D)  
 ; (101) (102) ;  
 , (109) ;  
 , (102) ; (105) (101) ,  
 (108) ;

**3.**

2 , (101) (106)

**4.**

; (103) (110) (D)  
 ; (110) (102)  
 ; (110) (102) (111)  
 (102) ; , (105) (110) ,  
 (108) ;

**5.**

(104) ; (103) (110) (D)  
 ; (110) (102)  
 ; (110) (102) (111)  
 (110) ; (104) (111)  
 (110) ; , (105) (110) ,  
 (108) ;

**6.**

가 ,  
 가 가 ; (103) (101) (D)  
 가 ; (101) (102)  
 ; , (102) ; (105) (101) ,  
 (108) 가 ;

**7.**

가 ,

가 ; (103) (101) (D)  
 가 ; (101) (102) ,  
 가 ; , (109) (105) (101) ,  
 (108) 가 ; ,  
 8.  
 9.  
 1 7 , (105) (107) ,  
 10. 7 , ( ) ,  
 ; ,  
 11. 7 , ,  
 ; ,  
 12. , (204) (203) ; (201) , ;  
 (203) (202) ;  
 , \_\_\_\_\_ ;  
 13. , (303) ; \_\_\_\_\_ (306)  
 (302) (301) ;  
 가 (305) (304) (306) ; ,  
 \_\_\_\_\_ ;  
 14. (403) ; ;  
 , (401) ; ;  
 (402) (402) ; ;  
 (404) , (405) ;  
 .  
 15. (403) ; ;  
 , (401) ; ;  
 (402) ; , ( )  
 ( ) ; ,  
 .  
 16. 12 15 , , ;  
 .  
 17.



12

15

18.

(112) (101) (D)  
(101) (102)  
(109)  
(102) (105) (101)  
(108)

1

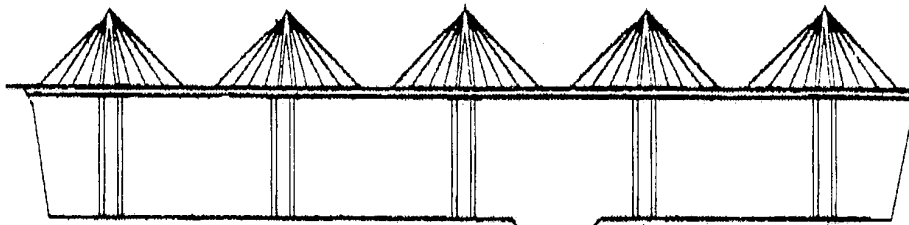

2a

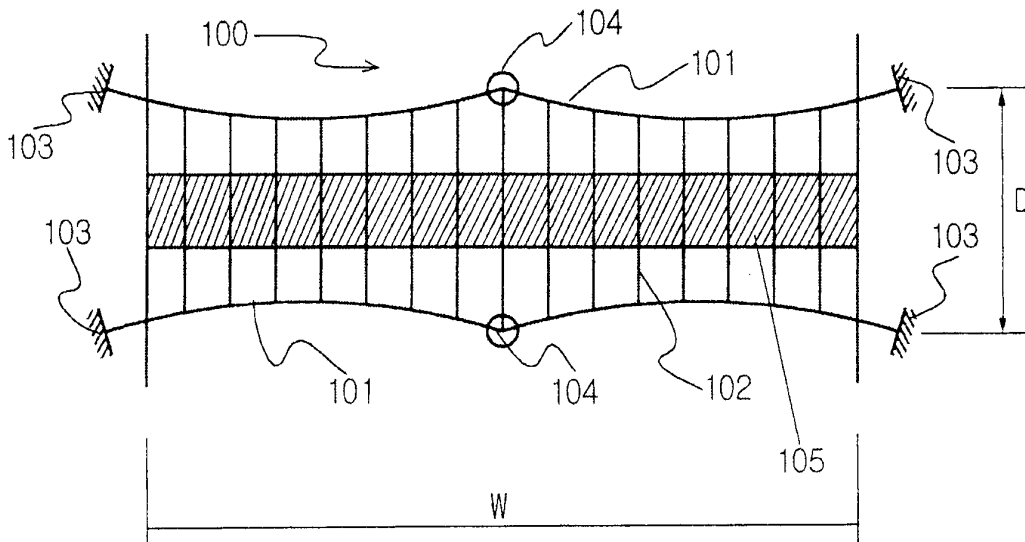

2b

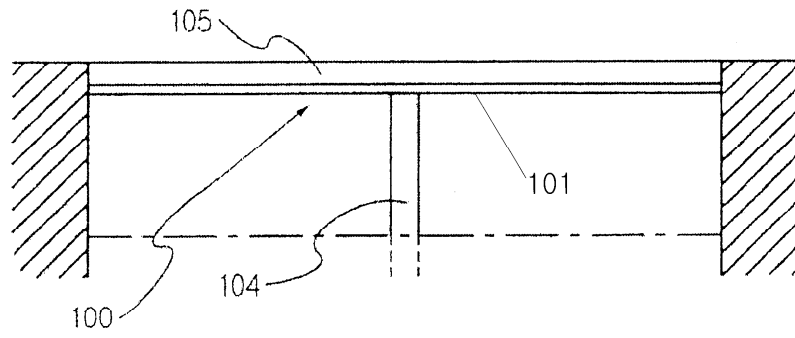

2c

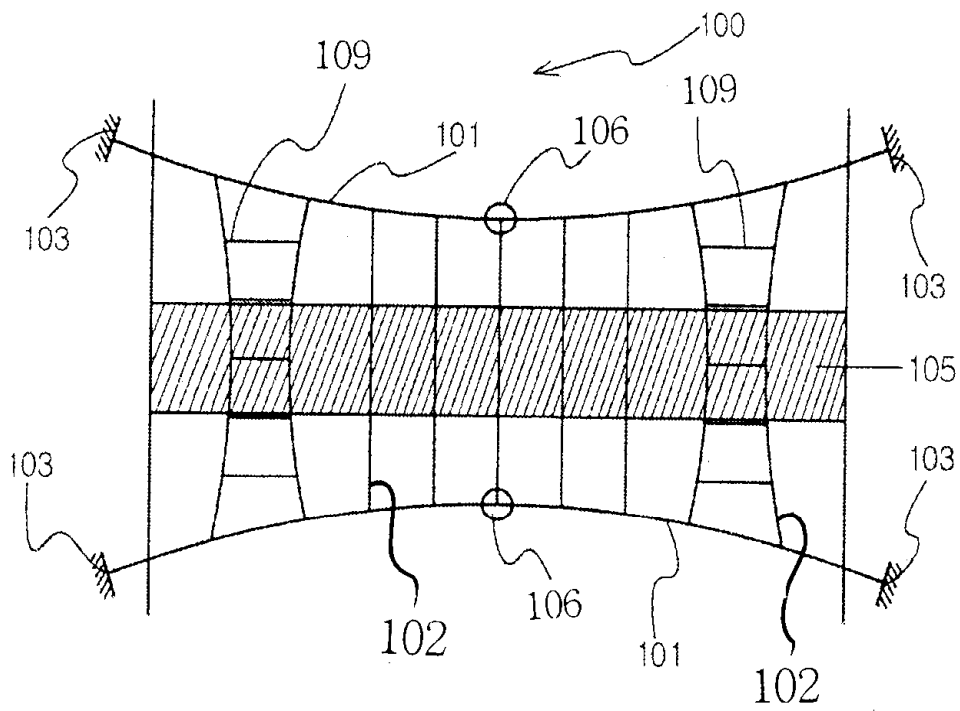

3a

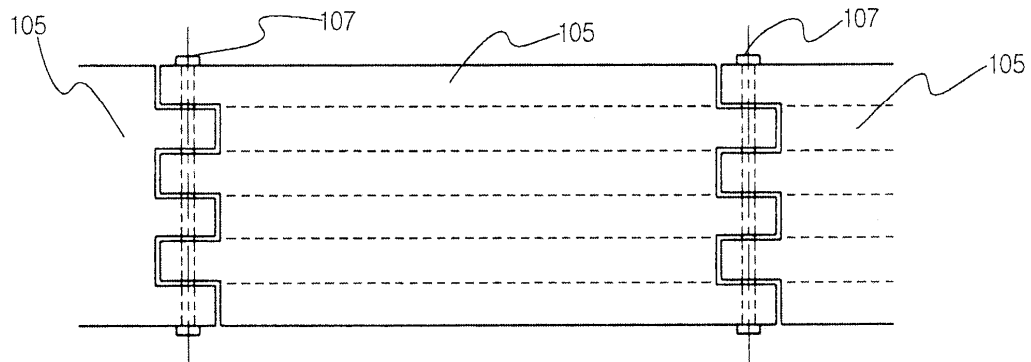

3b

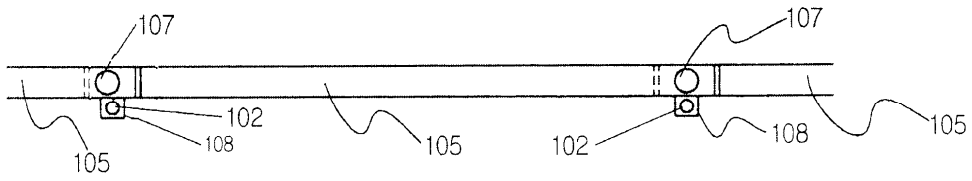

4a

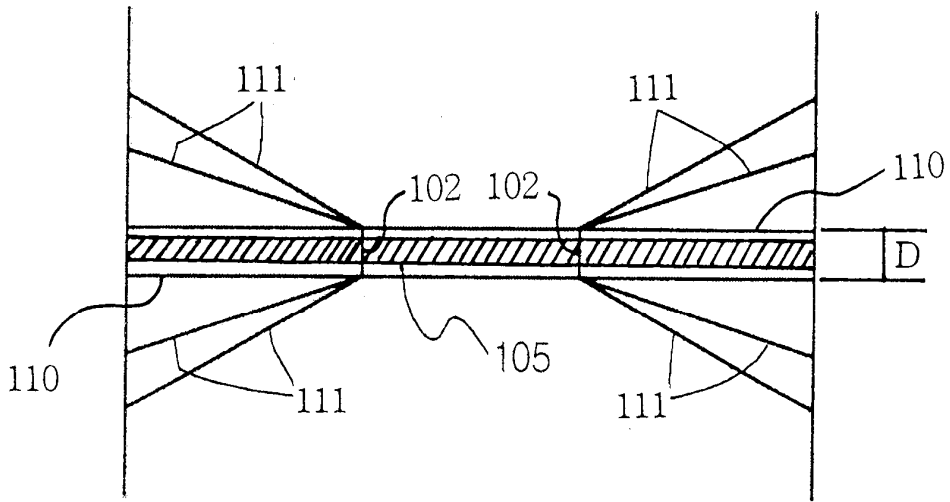

4b

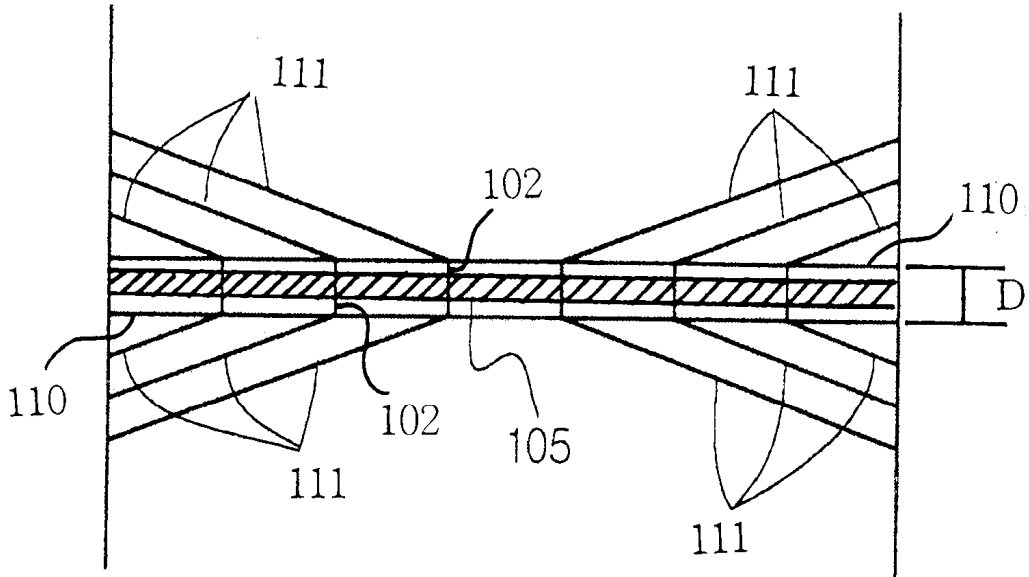

4c

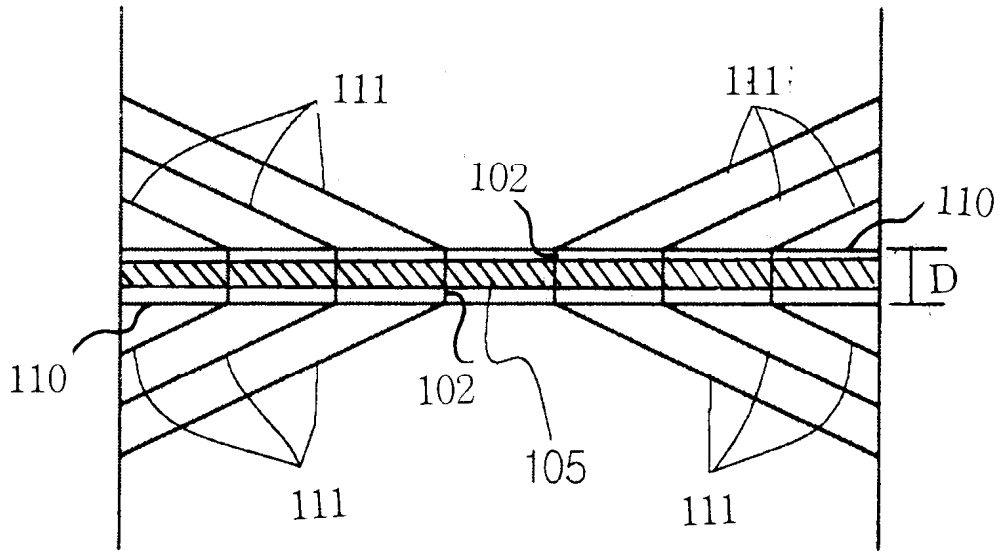

4d

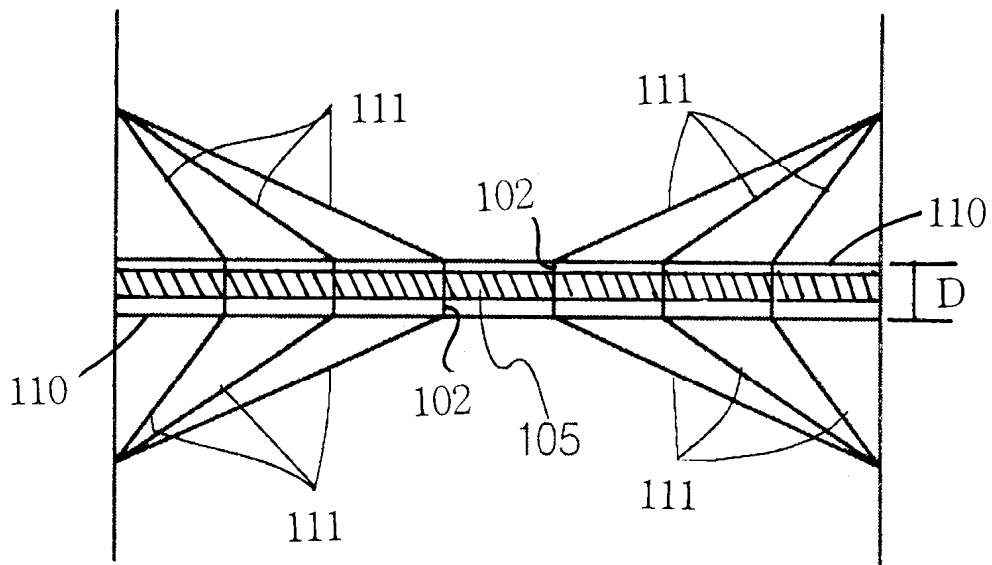

4e

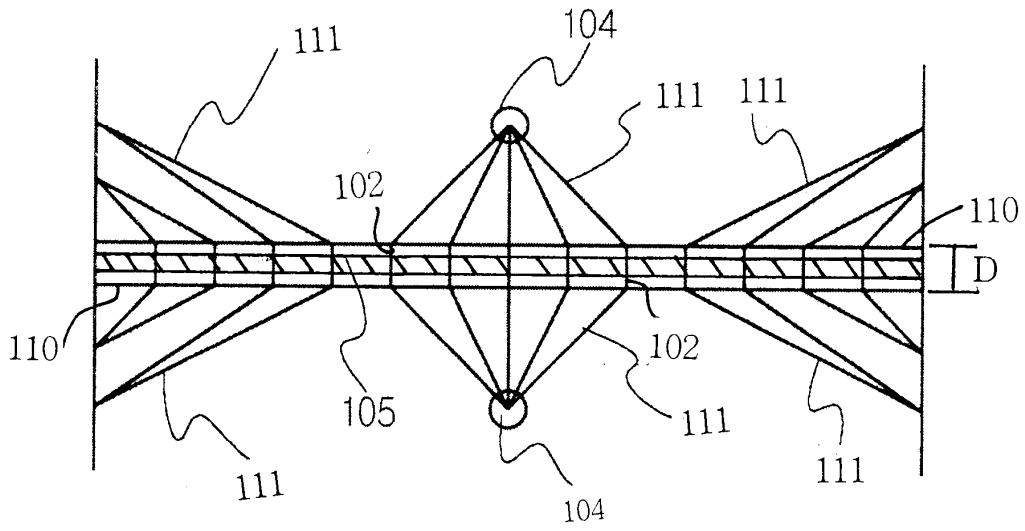

4f

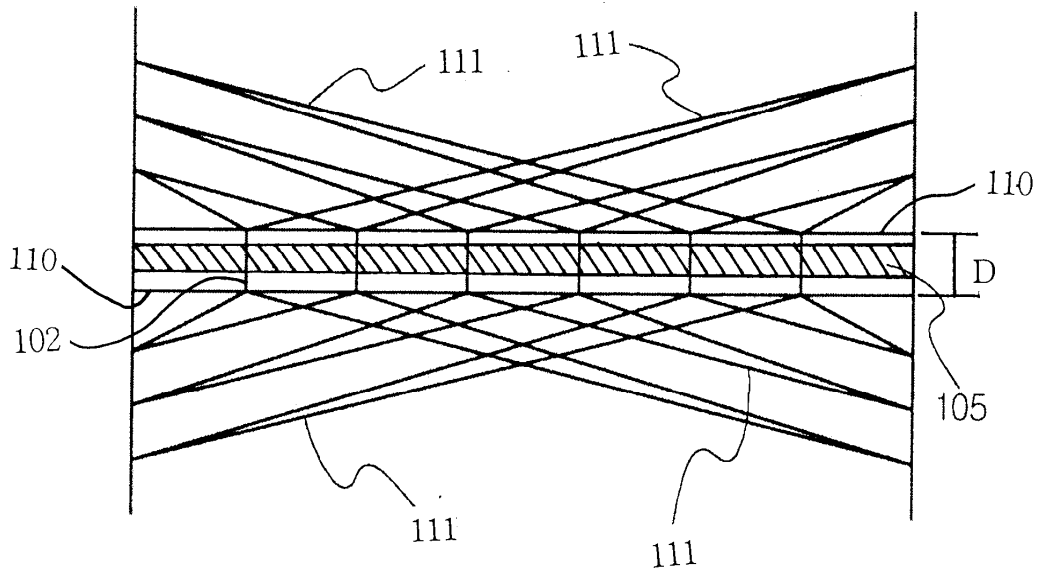

4g

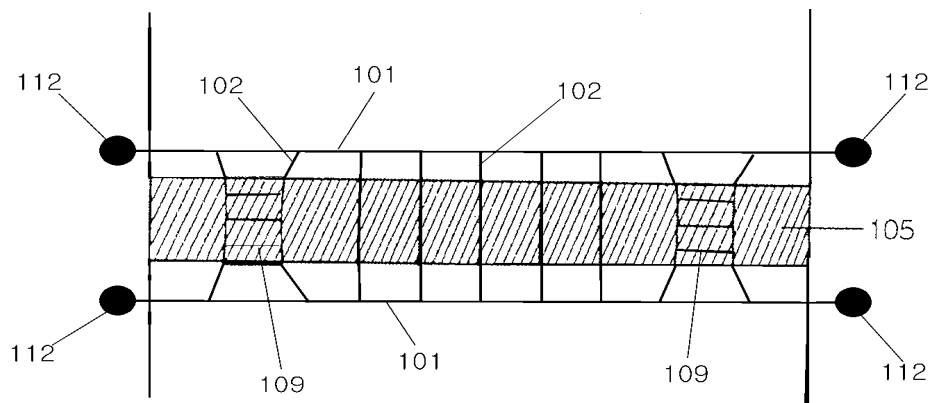

5a

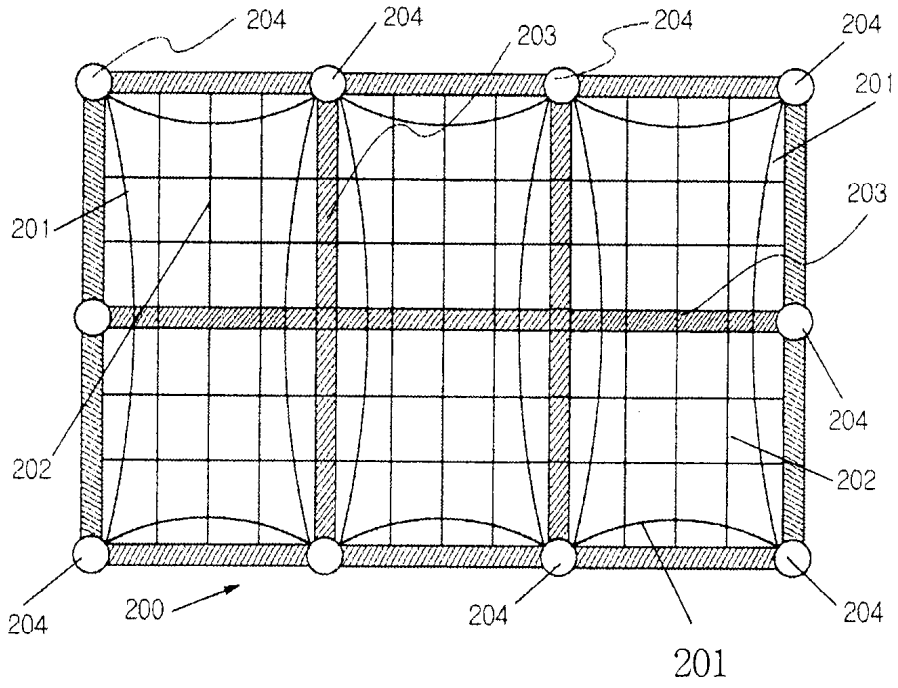

5b

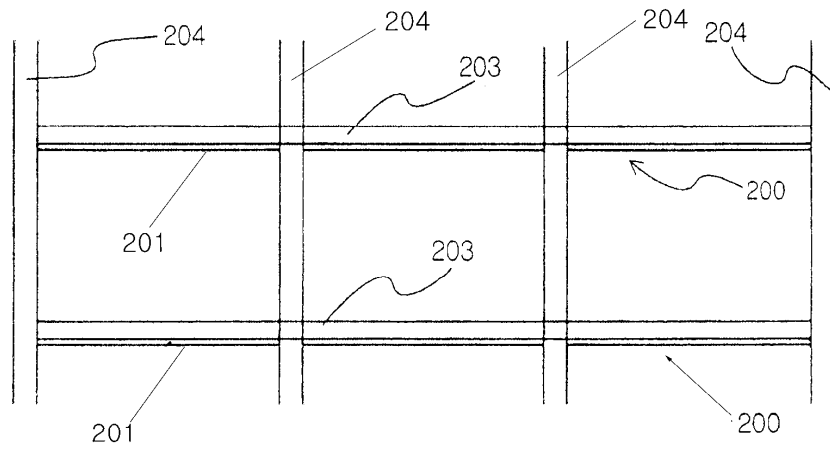

6

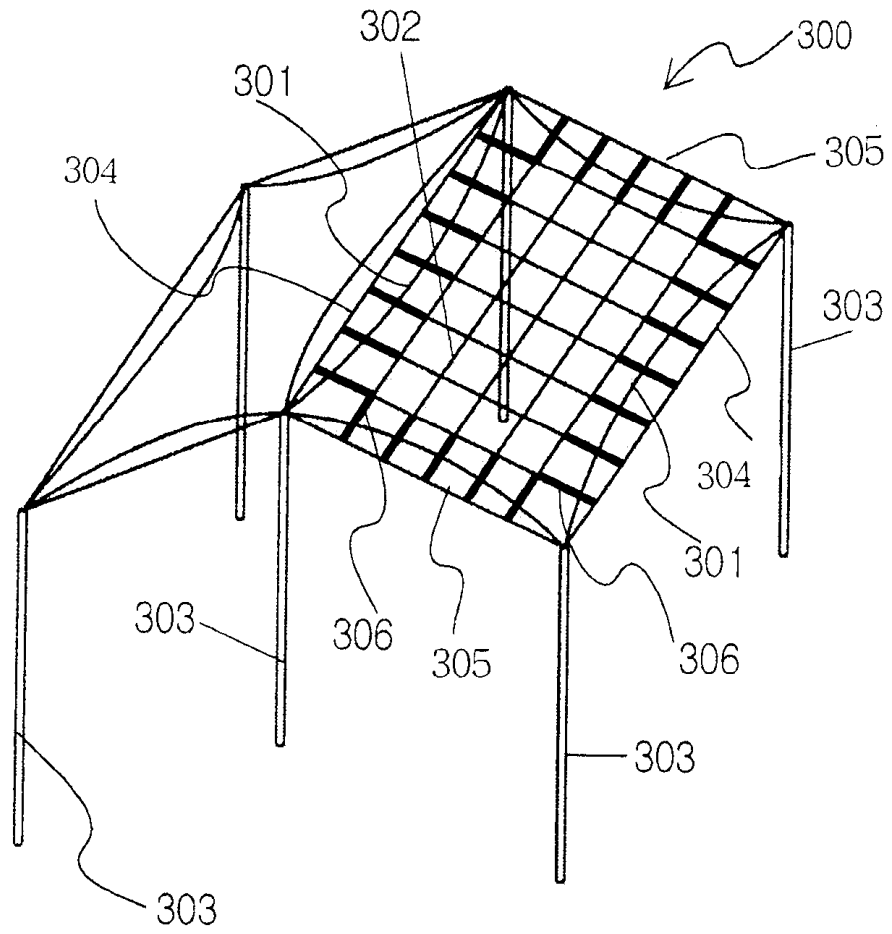

7a

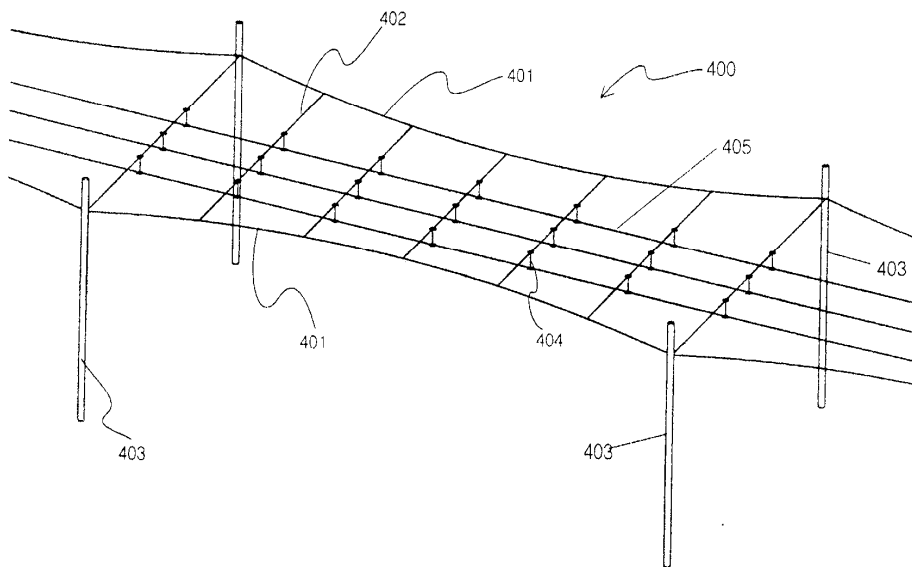

7b

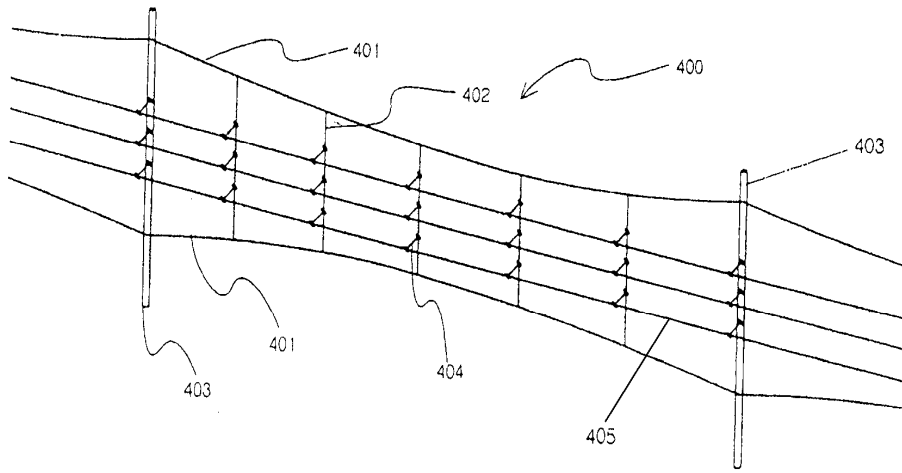

8a

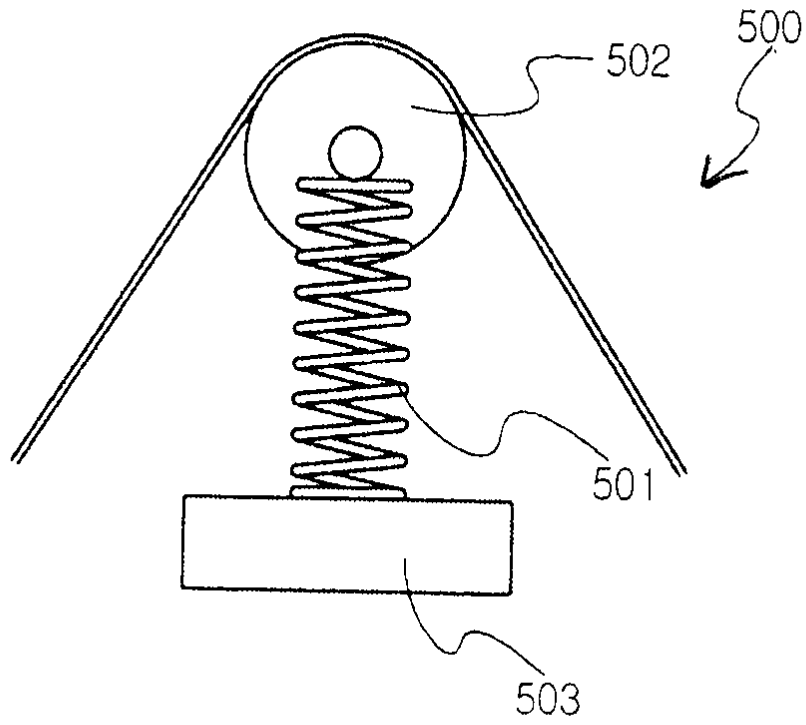

8b

