



US00D809688S

(12) **United States Design Patent** (10) **Patent No.:** **US D809,688 S**  
**Christensen** (45) **Date of Patent:** **\*\* Feb. 6, 2018**

(54) **LANTERN**  
(71) Applicant: **Simple Products Corporation**, Draper, UT (US)  
(72) Inventor: **Brian Christensen**, Draper, UT (US)  
(73) Assignee: **Simple Products Corporation**, Draper, UT (US)

D658,324 S \* 4/2012 Reimann ..... D26/40  
D707,378 S \* 6/2014 Shiu ..... D26/41  
D725,300 S \* 3/2015 Dalton ..... D26/40  
9,217,547 B2 \* 12/2015 Sharrah ..... F21L 4/005  
D747,022 S \* 1/2016 Leung ..... D26/40  
D747,523 S \* 1/2016 Salmon ..... D26/40  
D748,836 S \* 2/2016 Zhang ..... D26/40  
D754,379 S \* 4/2016 Green ..... D26/113  
D759,869 S \* 6/2016 Huang ..... D26/41

\* cited by examiner

(\*\*) Term: **15 Years**  
(21) Appl. No.: **29/551,893**

*Primary Examiner* — Lakiya Rogers  
*Assistant Examiner* — Carissa C Fitts  
(74) *Attorney, Agent, or Firm* — Thorpe North & Western, LLP

(22) Filed: **Jan. 18, 2016**  
(51) **LOC (11) Cl.** ..... **26-02**  
(52) **U.S. Cl.** .....  
USPC ..... **D26/41**  
(58) **Field of Classification Search**  
USPC ..... D26/37, 38, 40, 41, 42, 46, 50, 51  
CPC ... F21L 4/025; F21L 4/027; F21L 4/04; F21L 4/08; F21L 2005/00; F21L 7/00; F21L 11/00; F21L 13/00; F21L 13/04; F21L 13/08; F21L 14/02; F21L 17/00; F21L 19/00; F21L 25/00  
See application file for complete search history.

(57) **CLAIM**

The ornamental design for a lantern, as shown and described.

**DESCRIPTION**

FIG. 1 is a front view of a lantern in accordance with my invention;  
FIG. 2 is a right view thereof;  
FIG. 3 is a left view thereof;  
FIG. 4 is a back view thereof;  
FIG. 5 is a top view thereof; and,  
FIG. 6 is a bottom view thereof.  
The broken lines show portions of the lantern which form no part of the claimed design.

(56) **References Cited**

U.S. PATENT DOCUMENTS

D547,891 S \* 7/2007 Shiu ..... D26/40  
D571,493 S \* 6/2008 Li ..... D26/37  
D583,492 S \* 12/2008 Jen ..... D26/40  
D599,923 S \* 9/2009 Shiu ..... D26/40  
D650,104 S \* 12/2011 Brands ..... D26/41

**1 Claim, 5 Drawing Sheets**

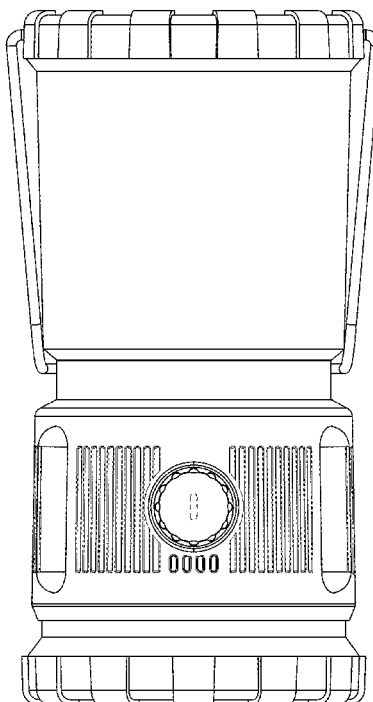

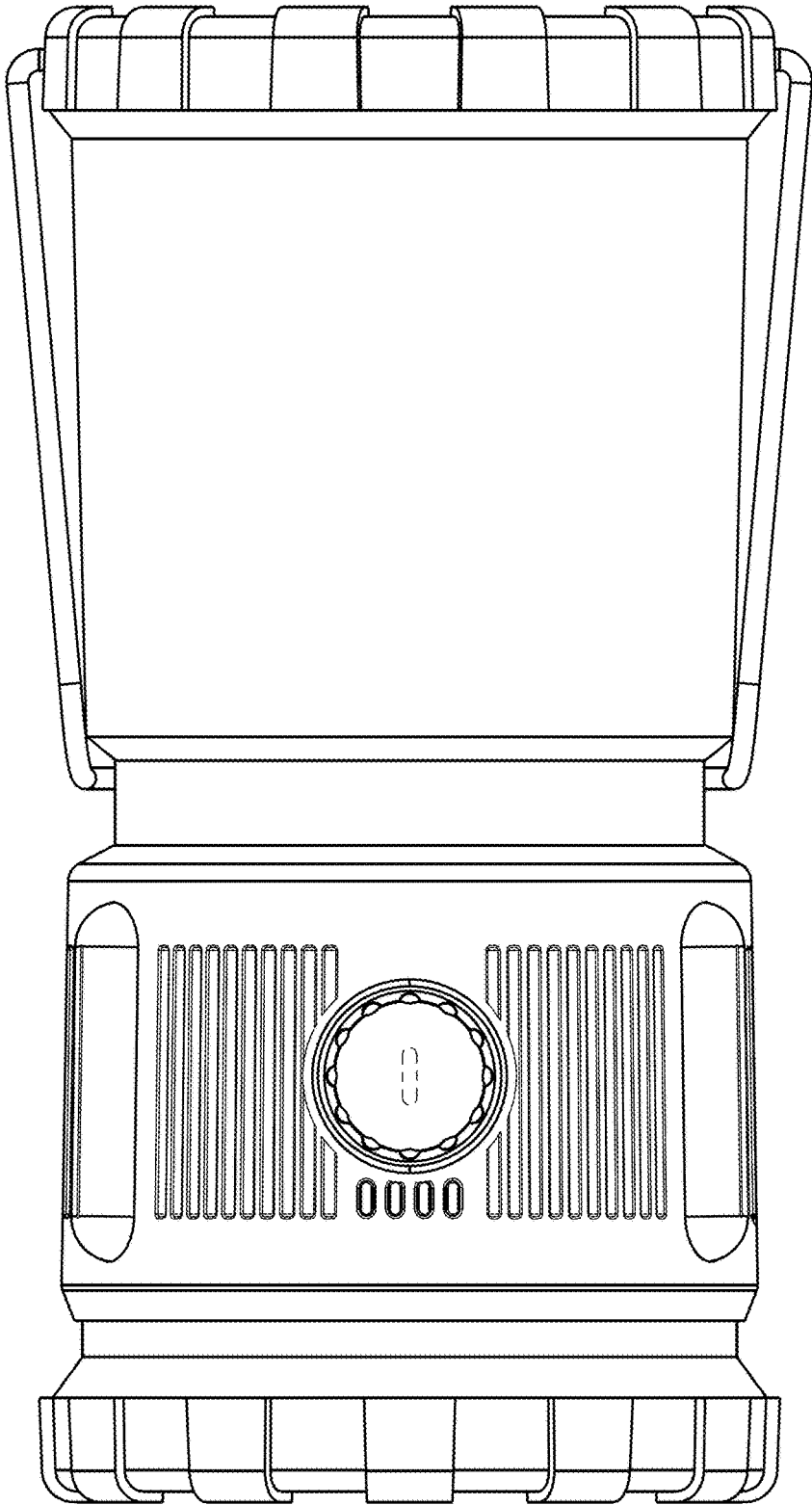

**FIG. 1**

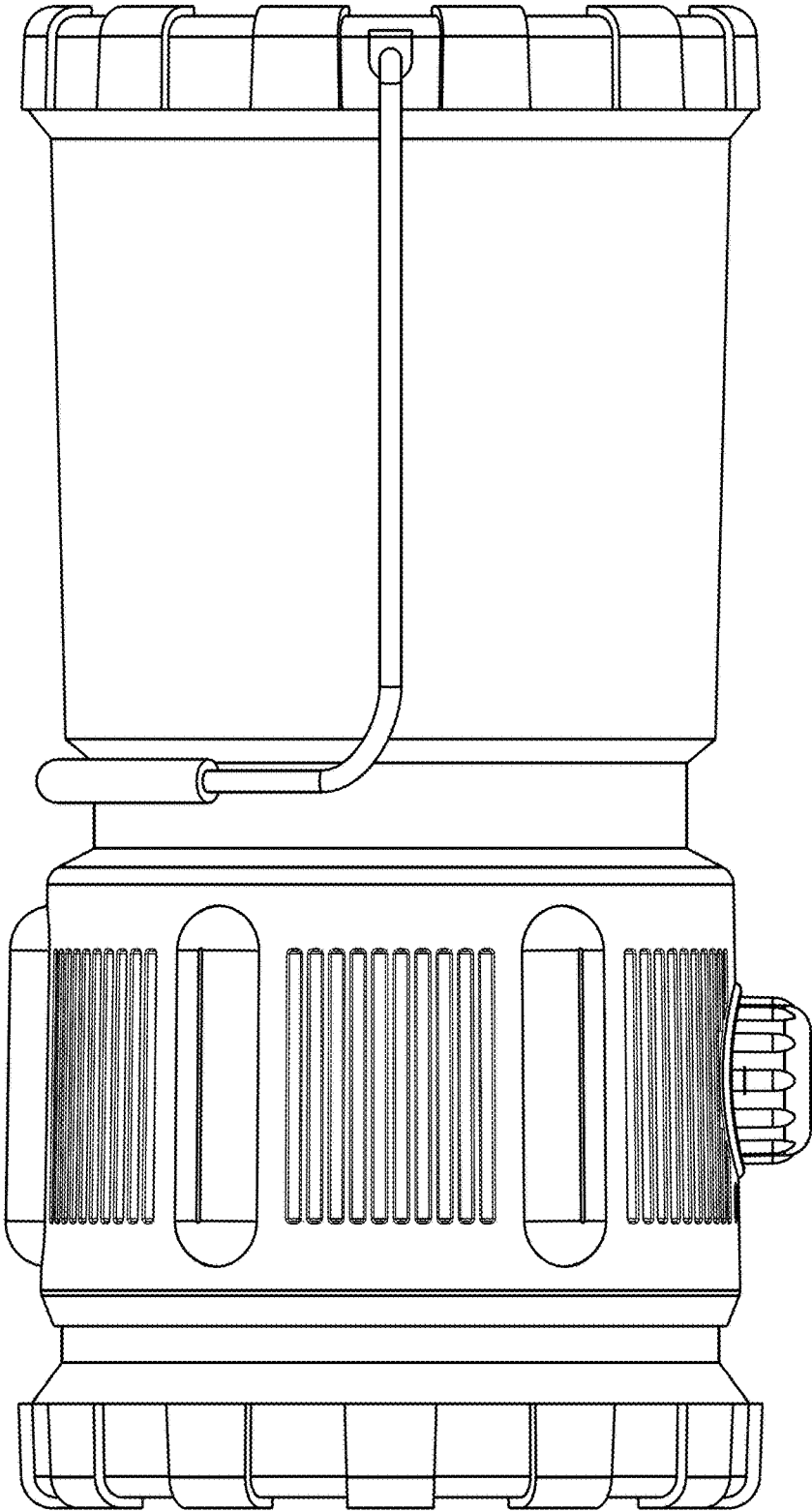

FIG. 2

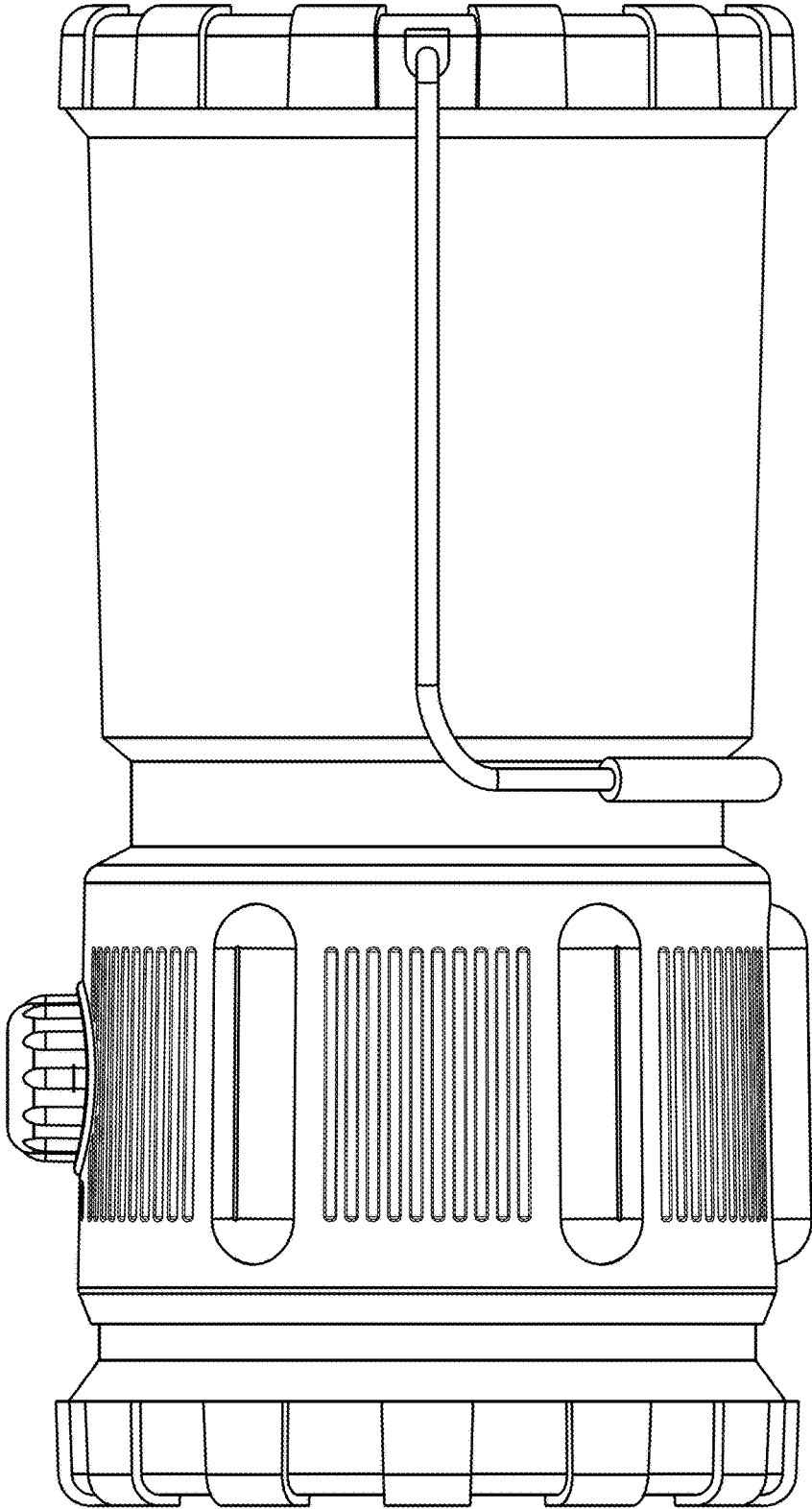

FIG. 3

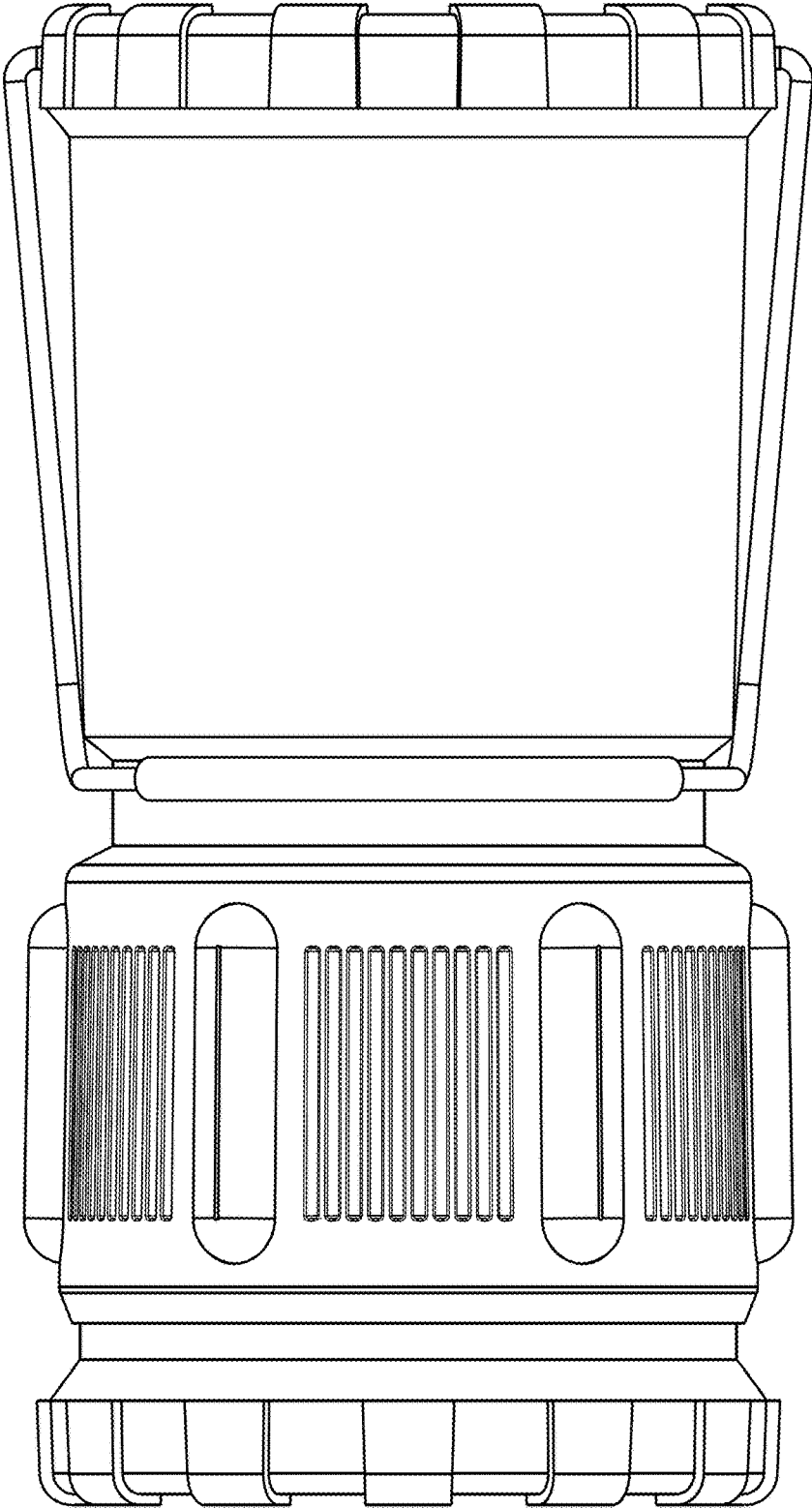

FIG. 4

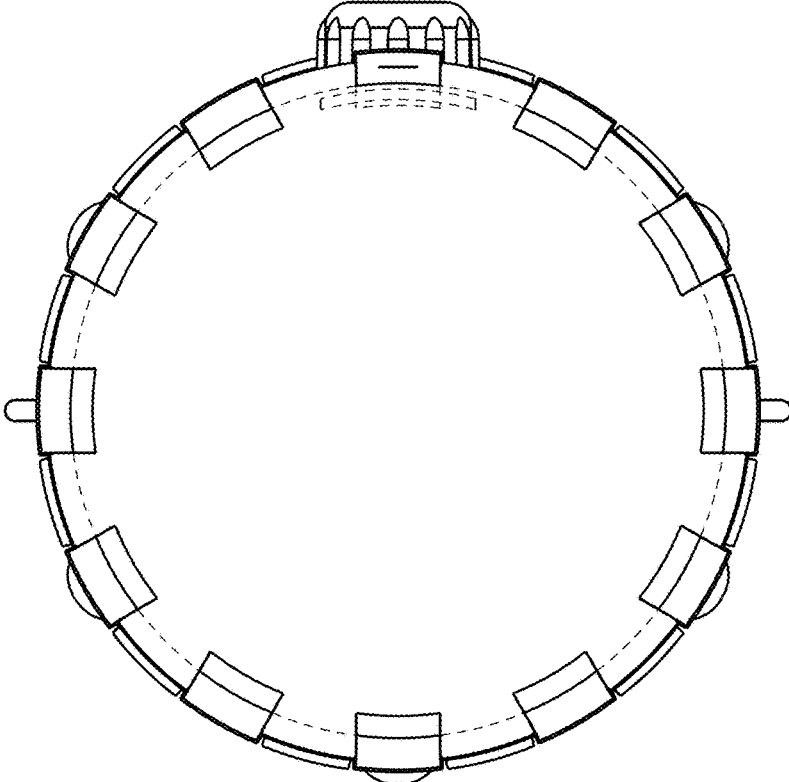

FIG. 5

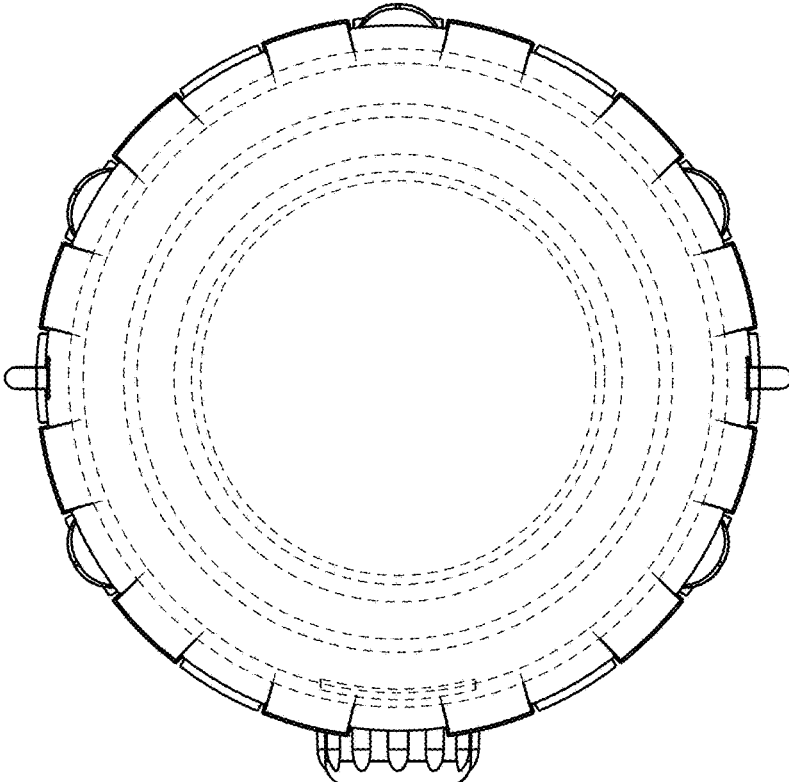

FIG. 6