

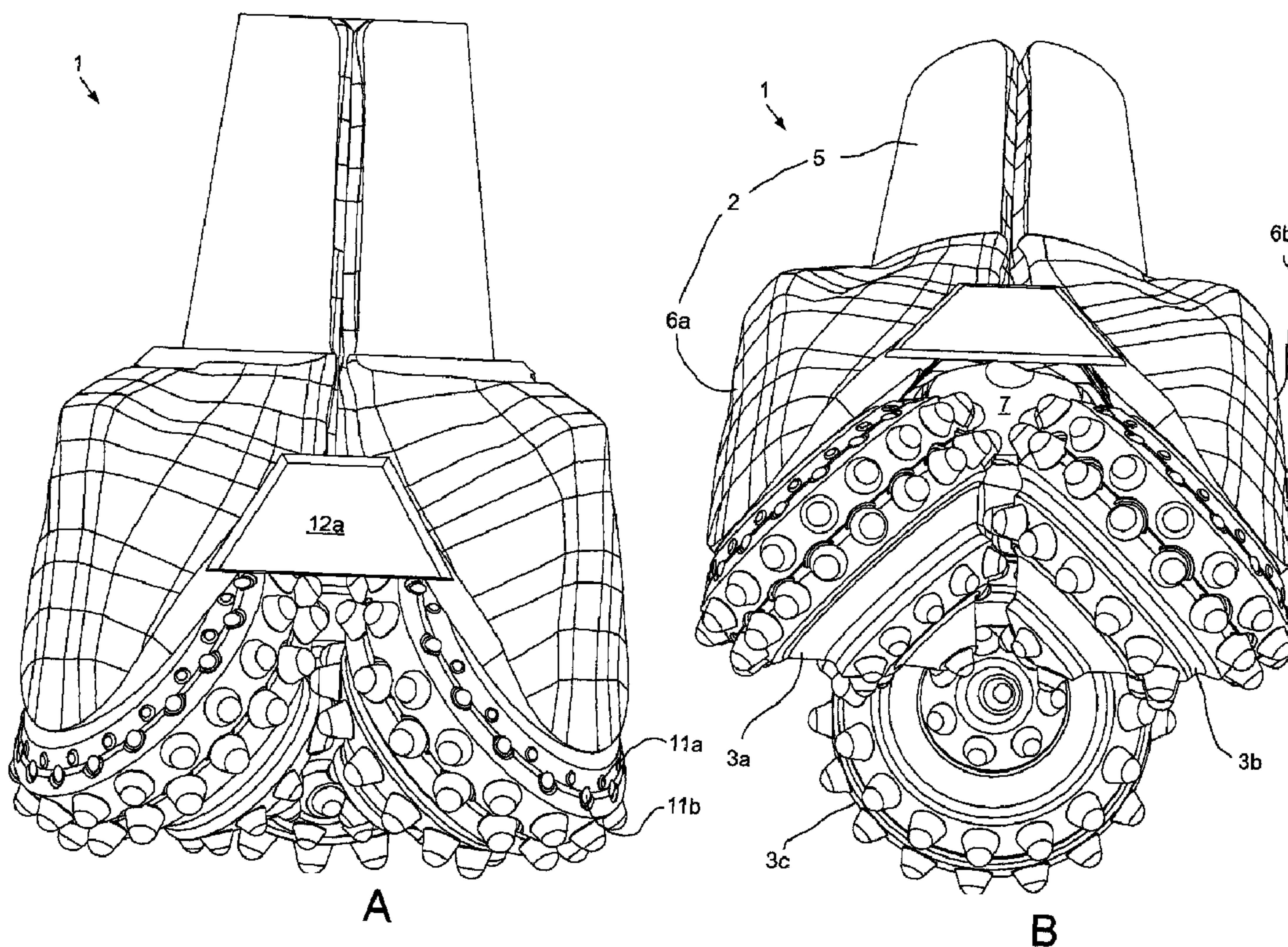

(22) Date de dépôt/Filing Date: 2017/07/20
(41) Mise à la disp. pub./Open to Public Insp.: 2018/02/09
(30) Priorité/Priority: 2016/08/09 (US62/372,493)

(51) Cl.Int./Int.Cl. *E21B 10/08* (2006.01),
E21B 10/18 (2006.01), *E21B 10/50* (2006.01)
(71) Demandeur/Applicant:
VAREL INTERNATIONAL IND., L.P., US
(72) Inventeurs/Inventors:
BEAVERS, TONY JACK, US;
KONGAMNACH, AMNACH, US...
(74) Agent: GOWLING WLG (CANADA) LLP

(54) Titre : TREPAN DURABLE DESTINE AU FORAGE DE TROU DE MINE
(54) Title: DURABLE ROCK BIT FOR BLAST HOLE DRILLING



(57) Abrégé/Abstract:

A rock bit for blast hole drilling includes: a bit body having a coupling formed at an upper end thereof, a plurality of lower legs, a dome formed between the legs, and a bore formed through the coupling and the dome; a plurality of skirts, each skirt covering a

(57) **Abrégé(suite)/Abstract(continued):**

gap formed between adjacent legs and each skirt mounted to edges of adjacent legs; a plurality of roller cones, each rotary cone rotatably mounted to a respective bearing shaft of a respective leg; a row of gage cutters mounted to each roller cone; a row of inner cutters mounted to each roller cone; one or more nose cutters mounted to each roller cone; and a center jet secured in the bore. Each cutter is an insert.

ABSTRACT OF THE DISCLOSURE

A rock bit for blast hole drilling includes: a bit body having a coupling formed at an upper end thereof, a plurality of lower legs, a dome formed between the legs, and a bore formed through the coupling and the dome; a plurality of skirts, each skirt covering a gap formed between adjacent legs and each skirt mounted to edges of adjacent legs; a plurality of roller cones, each rotary cone rotatably mounted to a respective bearing shaft of a respective leg; a row of gage cutters mounted to each roller cone; a row of inner cutters mounted to each roller cone; one or more nose cutters mounted to each roller cone; and a center jet secured in the bore. Each cutter is an insert.

DURABLE ROCK BIT FOR BLAST HOLE DRILLING

BACKGROUND OF THE DISCLOSURE

Field of the Disclosure

[0001] The present disclosure generally relates to a durable rock bit for blast hole drilling.

Description of the Related Art

[0002] CN 2475815 discloses a cone bit, particularly a hydraulic structure for a tri-cone bit, which includes three cone legs. The upper parts of the three cone legs are combined into a whole, the lower end of each cone leg is provided with a cone, and the middle part of the lower part of a bit body is provided with a center nozzle. The periphery of the bit body between the cone legs is provided with a wiper block which is provided with a reverse edge nozzle with an upward jet hole. An auxiliary nozzle can also be arranged along the circumferential direction of the center nozzle. The bit effectively improves a flow field at the bottom of a well and enhances the rock removing effect of the main jet in order to enhance the speed rate of a well drilling to reduce the integrated cost of the well drilling.

[0003] CN 203463013 discloses a tricone bit including a bit main body and a bit cone leg which is arranged on the bit main body; a bit cone is arranged on the bit cone leg; the back of the bit cone leg is provided with an oil storage compensation pressure balance system; the middle of the bit main body is provided with a center water hole; one end of the center water hole, which is close to the bit cone, is provided with a replaceable alloy nozzle. An alloy nozzle holder which is arranged in the center water hole of the tricone bit is convenient to machine, the alloy nozzle is convenient to replace, the different diameters of alloy nozzles can be replaced according to the working conditions, and accordingly workers can perform well drilling well by utilizing the water power of the drilling fluid; the space of a rising rock debris flow channel which is formed by machining is sufficient and accordingly rock debris can rise and the mechanical drilling speed can be improved; the oil storage compensation pressure balance system is arranged on the back side of the bit cone leg and accordingly the distance to a bearing is small and the grease compensation is timely and meanwhile an oil storage compensation pressure balance and bearing

sealing system is integral and effective and accordingly the service life of the tricone bit can be greatly extended.

[0004] RU 2222683 discloses a roller bit including arms making body of bit, rolling cutters mounted in bearing assemblies and nozzle with cone internal hydraulic conduit located in central hole of body. Six longitudinal slits are made in wall of nozzle. Three equal slits with larger areas of outlet sections which expand along length from center to periphery of roller bit are arranged uniformly and are strictly directed into spaces between rolling cutters and three equal slot-shaped slits with smaller areas of outlet sections have identical width and are directed with inclination to surfaces of rolling cutters and their axes in plan are displaced with reference to axes of rolling cutters in direction of rotation of bit through angle $\alpha = 15/25$ DEG. Summary areas of outlet sections of larger and smaller slits are interrelated by following relationship $\Sigma F_{l.a} / \Sigma F_{s.a} = (2,0/3,5)$, where $\Sigma F_{l.a}$ and $\Sigma F_{s.a}$ are summary areas of outlet sections of correspondingly larger and smaller slits, sq mm.

[0005] US 3,439,757 discloses a well drilling apparatus for preventing excessive flow of fluid into a formation while at the same time maintaining the cones of a bit free from the cuttings. This apparatus includes concentrically arranged drilling pipes flow connected to a sub with the sub having a formation cutting bit attached to the lower depending end thereof. The sub and bit include longitudinally extending passageways, with one such passageway centrally extending through the sub and bit and into communication with the tubing located within the drill pipes, and with the remaining passageways being radially arranged to communicate with the annulus of the drill pipes. A cylindrical downwardly depending skirt is rigidly attached to the sub and downwardly depends about the drill bit, thereby enclosing the drill shanks therewithin. A weir in the form of a plate member is attached between adjacent shanks and is spaced apart from and enclosed by the lower terminal end of the skirt thereby providing a passageway for clean drilling fluid which flows from the drill pipe annulus and between the weir and skirt. The passageway forces the clean fluid to flow in close proximity of the drill cones to thereby maintain the cones free of debris in an improved manner. This action also removes large formation cuttings from the vicinity of the drill bit so as to prohibit further reduction in their size, thereby effecting

a savings in the expenditure of power which must be used by the cone, as well as immediately returning large cuttings or chips of the formation to the surface for analysis.

[0006] US 4,823,890 discloses a reverse circulation deep hole rock bit that includes a drill bit connector tube telescopically extended into a drill bit housing to cooperatively form a part of a radial inner fluid channel for cuttings to flow axially outwardly and a radial outer annular clearance space, a plurality of angularly spaced pressurized fluid passage that open to the annular space and a check valve in each fluid fluid passage to permit inward flow of fluid, but to block fluid flow in the opposite direction. A plurality of angularly spaced cutter arms have arcuate tubular segments secured to axial and radial outer portions of the arms while a radially inner tubular skirt is secured to or abuts against the axial outer portions of the arms. The combination of segments, arms and skirt are secured to the housing to extend inwardly thereof with the skirt forming part of the radial inner return channel while each passage opens to a separate chamber angularly between adjacent arms to direct pressurized fluid to flow between the rotary cutters that are mounted by the arms and convey cuttings outwardly through the radial inner fluid channel.

[0007] US 5,853,055 discloses a rotary cone bit for drilling bore holes in earth formations whose body has a thread pin end and a dome end from which extend three legs. A cutter cone is rotatably mounted to each leg and is radially oriented about the bit's central axis. Each cutter cone has a gage row of cutting elements extending from the cone surface nearest the mouth and a nose row extending nearest the cone's apex. A center jet for emitting fluid or mud is located on the dome. The jet has a converging nozzle with an exit orifice which extends below a predefined horizontal plane intersected by the cones or cutting elements. The exit orifice has a constant diameter for a length at least equal to its diameter for reducing the diffusion of the fluid or mud flow emitted. Fluid or mud emitted from the center jet travels substantially uninterrupted within a cylindrical space between the cones which is not invaded by any cutting element. This reduced diffusion substantially uninterrupted fluid flow strikes the bore hole bottom with maximum impact energy for enhanced removal of earth formation cuttings.

[0008] US 6,581,702 discloses a three-cone rock bit employing a non-plugging center jet nozzle with a plurality of staggered inlet orifices leading to side passageways to reduce bit balling. The nozzle defines a tapered cavity through which drilling mud flows and exits in streams. Streams are directed from the nozzle through a main exit aperture of sufficient size to avoid plugging and from side passageways boring through a sidewall of the nozzle. Jetting streams promote washing of voids within the bit and of cutting surfaces. The nozzle uses staggered inlet orifices leading to side passageways, in conjunction with a tapering shape of a central passageway to facilitate maintenance of drilling mud velocity within the central passageway and thus of stream velocity to targeted regions of the drill bit.

SUMMARY OF THE DISCLOSURE

[0009] The present disclosure generally relates to a durable rock bit for blast hole drilling. In one embodiment, a rock bit for blast hole drilling includes: a bit body having a coupling formed at an upper end thereof, a plurality of lower legs, a dome formed between the legs, and a bore formed through the coupling and the dome; a plurality of skirts, each skirt covering a gap formed between adjacent legs and each skirt mounted to edges of adjacent legs; a plurality of roller cones, each rotary cone rotatably mounted to a respective bearing shaft of a respective leg; a row of gage cutters mounted to each roller cone; a row of inner cutters mounted to each roller cone; one or more nose cutters mounted to each roller cone; and a center jet secured in the bore. Each cutter is an insert.

BRIEF DESCRIPTION OF THE DRAWINGS

[0010] So that the manner in which the above recited features of the present disclosure can be understood in detail, a more particular description of the disclosure, briefly summarized above, may be had by reference to embodiments, some of which are illustrated in the appended drawings. It is to be noted, however, that the appended drawings illustrate only typical embodiments of this disclosure and are therefore not to be considered limiting of its scope, for the disclosure may admit to other equally effective embodiments.

[0011] Figures 1A and 1B illustrate a durable rock bit for blast hole drilling, according to one embodiment of the present disclosure.

[0012] Figures 2A and 2B are cross-sectional views of the rock bit.

[0013] Figure 3A is an end view of the rock bit. Figure 3B is a cutting diagram of a first alternative durable rock bit for blast hole drilling, according to another embodiment of the present disclosure.

[0014] Figures 4A and 4B illustrate a center jet of the rock bit. Figures 4C and 4D illustrate an orifice plate of the center jet.

[0015] Figures 5A-5H illustrate alternative orifice plates usable with the center jet instead of the orifice plate, according to other embodiments of the present disclosure.

[0016] Figures 6A and 6B illustrate a second alternative durable rock bit for blast hole drilling, according to another embodiment of the present disclosure.

DETAILED DESCRIPTION

[0017] Figures 1A and 1B illustrate a durable rock bit 1 for blast hole drilling, according to one embodiment of the present disclosure. Figures 2A and 2B are cross-sectional views of the rock bit 1. Figure 3A is an end view of the rock bit 1. The rock bit 1 may include a body 2, a plurality of roller cones 3a-c, and a center jet 4. The body 2 may have an upper coupling 5, a lower leg 6a-c for each roller cone 3a-c, and a dome 7 formed between the legs. The body 2 and the roller cones 3a-c may each be made from a metal or alloy, such as steel. The body 2 may be made by attaching three forgings together, such as by welding. The legs 6a-c may be equally spaced around the body, such as three at one hundred twenty degrees. The upper coupling 5 may be a threaded pin for connection to a drill rod (not shown). A bore may be formed through the coupling and the dome 7 for discharging drilling fluid, such as air, onto interfaces between the cones 3a-c.

[0018] Each leg 6a-c may have an upper shoulder 8s, a mid shirrtail 8t, and a lower bearing shaft 8b. Each bearing shaft 8b may extend from the respective shirrtail 8t in a

radially inclined direction. Each bearing shaft 8b and the respective cone 3a-c may have one or more pairs of aligned grooves and each pair may form a race for receiving a set of roller bearings 9. One or more thrust washers (not shown) may be disposed between each bearing shaft 8b and the respective cone 3a-c. The roller bearings 9 and thrust washers may support rotation of each cone 3a-c relative to the respective leg 6a-c. Each leg 6a-c may have a passage 8p (only partially shown) extending from the bore to the bearings, thereby utilizing the drilling fluid for cooling and lubrication.

[0019] Alternatively, each leg 6a-c may include a pressure balanced lubricant reservoir, each passage 8p may lead to the respective reservoir instead of the bore, and a seal may be disposed between each bearing shaft 8b and the respective cone 3a-c.

[0020] Each roller cone 3a-c may be mounted to the respective leg 6a-c by a plurality of balls (not shown) received in a race formed by aligned grooves (not shown) in each roller cone and the respective bearing shaft 8b. The balls may be fed to each race by a ball passage (not shown) formed in each leg 6a-c and retained therein by a respective ball plug (not shown). Each ball plug may be attached to the respective leg 6a-c, such as by welding.

[0021] Each roller cone 3a-c may have a plurality of lands formed therein, such as one or more heel lands, a gage land, one or more inner lands, and a nose land. A row of gage cutters 10g may be mounted around each cone 3a-c at the respective gage land. A row of first inner cutters 10a may be mounted around each cone 3a-c at a respective first one of the inner lands. A row of second inner cutters 10b may be mounted around each cone 3a-c at a respective second one of the inner lands. One or more nose cutters 10n may be mounted on each cone 3a-c at the respective nose land. Each cutter 10a,b,g,n may be an insert mounted in a respective socket formed in the respective cone 3a-c by an interference fit. Each cutter 10a,b,g,n may be made from a cermet, such as a cemented carbide, and may have a cylindrical portion mounted in the respective cone and a conical portion protruding from a respective land of the respective cone 3a-c.

[0022] A row of first inner protectors 11a (Figure 1A) may be mounted around each cone 3a-c at a respective first one of the heel lands. A row of second inner protectors

11b (Figure 1A) may be mounted around each cone 3a-c at a respective second one of the heel lands. Each protector 11a,b may be an insert mounted in a respective socket formed in the respective cone 3a-c by an interference fit. Each protector 11a,b may be made from a cermet, such as a cemented carbide, and may be cylindrical.

[0023] Alternatively, at least some of the cutters 10a,b,g,n may be capped with polycrystalline diamond (PCD). Alternatively, at least some of the protectors 11a,b may be capped with PCD. Alternatively, each cutter 10a,b,g,n may have a protruding wedge portion instead of a protruding cylindrical portion.

[0024] The rock bit 1 may further include a plurality of skirts 12a-c for directing flow of drilling fluid discharged from the center jet 4 onto the interfaces between the cones 3a-c. The skirts 12a-c may each cover a gap formed between adjacent legs 6a-c to prevent the drilling fluid from flowing therethrough to an annulus formed between the drill rod and drill bit and a wall of the blast hole. Each skirt 12a-c may be mounted to edges of adjacent legs 6a-c, such as by welding. Each skirt 12a-c may be made from a metal or alloy, such as steel. Each skirt 12a-c may be trapezoidal plate extending straight across the respective gap.

[0025] Figure 3B is a cutting diagram of a first alternative durable rock bit 24 for blast hole drilling, according to another embodiment of the present disclosure. The first alternative rock bit 24 may be similar to the rock bit 1 except for having modified roller cones 25a-c instead of the roller cones 3a-c. Selected portions 13f,m of each modified roller cone 25a-c may be treated to resist erosion. The portions 13f,m may include a mouth 13m of each modified cone 25a-c and a face 13f of each cone located between the respective second inner land and the respective nose land. The treatment may include case hardening, such as carburizing, and/or a layer of hardfacing. The hardfacing may be a ceramic or cermet. A set of interstitial protectors 14 may be mounted on each modified cone 25a-c at the respective nose land and between adjacent nose cutters. Each interstitial protector 14 may be made from a cermet, such as a cemented carbide, and may have a cylindrical portion mounted in the respective cone and a dome portion protruding from a respective nose land of the respective modified cone 25a-c.

[0026] Alternatively, additional portions of the modified cones 25a-c may be treated to resist erosion, such as portions of the lands between the cutters, faces of the cones between the gage and inner rows and/or between the first and second inner rows. Alternatively, additional sets of interstitial protectors may be mounted to the modified cones 25a-c at the inner lands between adjacent cutters and/or at the gage land between adjacent cutters.

[0027] Figures 4A and 4B illustrate the center jet 4. Figures 4C and 4D illustrate an orifice plate 17 of the center jet 4. Referring also to Figure 2B, the center jet 4 may be disposed in the bore of the bit body 2 and may have an outer diameter corresponding to an inner diameter thereof, such as equal to or slightly less than, to form a sliding fit between the center jet and the bit body. The center jet 4 may be secured in the bore by a fastener, such as a snap ring 26, engaged with a groove (not shown) formed in an upper portion of the bore adjacent to the coupling 5. The center jet 4 may include a back flow valve 15, a screen tube 16, and the orifice plate 17. The components 15-17 of the center jet 4 may be arranged in a stack. Each component 15-17 may be cylindrical. Each of the back flow valve 15 and the screen tube 16 may have a bore formed therethrough.

[0028] The back flow valve 15 may include a housing 15h, a pair of wings 15w pivotally connected to the housing by a hinge pin 15p, and a biasing member, such as a torsion spring 15s (Figure 2B). Each wing 15w may pivot about the hinge pin 15h between an open position (not shown) and a closed position (shown). The torsion spring 15s may be wrapped around the hinge pin 15p and may bias the wings 15w toward the closed position. The housing 15h may have a seat formed in an inner surface thereof for receiving a periphery of the wings 15w in the closed position, thereby shutting a bore of the housing. The wings 15w may be moved from the closed position to the open position by injection of the drilling fluid down the bore of the bit body 2 and may close if flow is ceased or may close to block upward flow. The hinge pin 15p may be received in sockets formed in a wall of the housing 15h and mounted to the housing, such as by an interference fit.

[0029] The screen tube 16 may have set of slots 16s formed through a wall thereof for each passage 8p. The slots 16s may be aligned with inlets of the passages 8p and each set of slots may be oriented to face a respective passage. The slots 16s may divert a portion of the drilling fluid from the bore thereof to the passages 8p. The slots 16s may be sized to filter particulates from entering the passages 8p and reaching the bearings 9. The screen tube 16 may have an orienting feature, such as a boss 16b, formed in a lower end thereof.

[0030] The orifice plate 17 may have an outer flange 17f formed in an upper end thereof and a port 17p formed therethrough for each cone 3a-c. The flange 17f may have an orienting feature, such as a notch 17n, formed therein for mating with the boss 16b, thereby torsionally connecting the orifice plate 16 and the screen tube 15. The bit body 2 may also have a seat 2s (Figure 2B) formed therein adjacent to the bore for receiving the flange 17f and the seat may also have a notch (not shown) for mating with the boss 16b to ensure orientation of the slots 16s relative to the passages 8p and aiming of the ports 17p at the interfaces between the cones 3a-c. The ports 17p may diverge from the flange to a bottom of the orifice plate 17 to direct discharge of the drilling fluid downward and radially outward toward the interfaces between the cones 3a-c. An angle 27 of this divergence (measured relative to a longitudinal centerline of the rock bit 1) may range between three and forty degrees or zero (non-divergent) and sixty degrees.

[0031] Figures 5A-5H illustrate alternative orifice plates 18-21 usable with the center jet 4 instead of the orifice plate 17, according to other embodiments of the present disclosure. A first alternative orifice plate 18 may have a cylindrical upper portion, a lower dome portion, a plenum formed therein, a side port for each cone 3a-c, and a center port. A diameter of each side port may decrease from the plenum to an outer surface of the dome portion to create a nozzle effect. The center port of the first alternative orifice plate 18 may direct discharge of the drilling fluid downward to erode a center of a bottom of the blast hole. The side ports may diverge from the cylindrical upper portion to the lower dome portion to direct discharge of the drilling fluid downward and radially outward toward the interfaces between the cones 3a-c. An angle of this divergence (measured relative

to a longitudinal centerline of the rock bit 1) may range between three and forty degrees or zero (non-divergent) and sixty degrees.

[0032] A second alternative orifice plate 19 may have a cylindrical upper portion, a lower conical portion, a plenum formed therein, a side port for each cone 3a-c, and a center port. A diameter of each side port may be substantially greater than a diameter of the center port. The side ports may diverge from the cylindrical upper portion to the lower conical portion to direct discharge of the drilling fluid downward and radially outward toward the interfaces between the cones 3a-c. An angle of this divergence (measured relative to a longitudinal centerline of the rock bit 1) may range between three and forty degrees or zero (non-divergent) and sixty degrees.

[0033] A third alternative orifice plate 20 may have only one center port. A diameter of the center port may increase from a flange thereof to a bottom thereof to create a diffuser effect. A wall of the third alternative orifice plate 20 adjacent to the center port may be inclined at an angle (measured relative to a longitudinal centerline of the rock bit 1) that may range between three and forty degrees or zero (non-divergent) and sixty degrees.

[0034] A fourth alternative orifice plate 21 may have a single Y-shaped port. Each branch portion of the Y-shaped port may diverge from a flange of the fourth alternative orifice plate 21 to a bottom thereof to direct discharge of the drilling fluid downward and radially outward toward the interfaces between the cones 3a-c. An angle of this divergence (measured relative to a longitudinal centerline of the rock bit 1) may range between three and forty degrees or zero (non-divergent) and sixty degrees.

[0035] Figures 6A and 6B illustrate a second alternative durable rock bit 22 for blast hole drilling, according to another embodiment of the present disclosure. The second alternative rock bit 22 may be similar to the rock bit 1 except for having modified skirts 23a-c instead of the skirts 12a-c. Each modified skirt 23a-c may direct flow of drilling fluid discharged from the center jet 4 onto the interfaces between the cones 3a-c. The modified skirts 23a-c may each cover a gap formed between adjacent legs 6a-c to prevent the drilling fluid from flowing therethrough to the annulus. Each modified skirt 23a-c may

be mounted to edges of adjacent legs 6a-c, such as by welding. Each modified skirt 23a-c may be made from a metal or alloy, such as steel. Each modified skirt 23a-c may be arcuate and may extend along a curved path across the respective gap, such that when the alternative rock bit 22 is viewed from a bottom thereof, a foot print of the skirts and the gage lands of the cones 3a-c resembles a circle.

[0036] Advantageously, the center jet 4 and either skirt configuration provide superior cuttings removal capability versus prior art rock bits. Insufficient cuttings removal causes cuttings to stagnate at the bottom of the blast hole until they are sufficiently ground to be evacuated. This regrinding of cuttings produces wear around the shirrtail lip, exposes the bearings, and leads to eventual bearing failure. This constant regrind also effects cone integrity. As the cuttings are ground, small, abrasive particles are produced that abrade the metallic cones, exposing a base of the cutters and eventually leading to cutter loss. Further, any of the rock bits 1, 22, 24 may achieve the superior cuttings removal without any additional nozzles or ports besides the center jet 4.

[0037] Alternatively, any of the rock bits 1, 22, 24 may be used to drill wellbores for crude oil and/or natural gas exploration and/or production or for geothermal power generation.

[0038] While the foregoing is directed to embodiments of the present disclosure, other and further embodiments of the disclosure may be devised without departing from the basic scope thereof, and the scope of the invention is determined by the claims that follow.

Claims:

1. A rock bit for blast hole drilling, comprising:
 - a bit body having a coupling formed at an upper end thereof, a plurality of lower legs, a dome formed between the legs, and a bore formed through the coupling and the dome;
 - a plurality of skirts, each skirt covering a gap formed between adjacent legs and each skirt mounted to edges of adjacent legs;
 - a plurality of roller cones, each rotary cone rotatably mounted to a respective bearing shaft of a respective leg;
 - a row of gage cutters mounted to each roller cone;
 - a row of inner cutters mounted to each roller cone;
 - one or more nose cutters mounted to each roller cone; and
 - a center jet secured in the bore,wherein each cutter is an insert.
2. The bit of claim 1, wherein:
 - the bit further comprises a plurality of sets of roller bearings, each set disposed between a respective cone and a respective bearing shaft, and
 - each leg has a passage extending from the bore to the respective set of bearings.
3. The bit of claim 2, wherein:
 - the center jet comprises a tube having a plurality of sets of slots aligned with inlets of the passages, and
 - each set of slots is oriented to face a respective passage
4. The bit of claim 1, wherein the center jet comprises an orifice plate having a plurality of ports, each port aimed at an interface between adjacent roller cones.
5. The bit of claim 4, wherein the orifice plate further has a center port aimed downward.

6. The bit of claim 4, wherein the orifice plate further has a plenum formed therein.
7. The bit of claim 1, wherein the orifice plate further has a single port with a center portion aimed downward and a plurality of branch portions, each branch portion aimed at an interface between adjacent roller cones.
8. The bit of claim 1, further comprising a set of interstitial protectors mounted on each roller cone.
9. The bit of claim 8, wherein the interstitial protectors are located between adjacent nose cutters.
10. The bit of claim 1, wherein at least a portion of each cone is treated to resist erosion.
11. The bit of claim 10, wherein the treatment is case hardening.
12. The bit of claim 10, wherein the treatment is hardfacing.
13. The bit of claim 10, wherein the treated portion is located between the inner cutters and the nose cutters and at a mouth of each cone.
14. The bit of claim 1, wherein each skirt extends straight across the respective gap.
15. The bit of claim 1, wherein each skirt is arcuate and extends along a curved path across the respective gap, such that when the rock bit is viewed from a bottom thereof, a foot print of the skirts and gage lands of the cones resembles a circle.
16. The bit of claim 1, wherein the center jet comprises a back flow valve operable to open in response to injection of drilling fluid down the bore and to close for blocking upward flow through the bore.

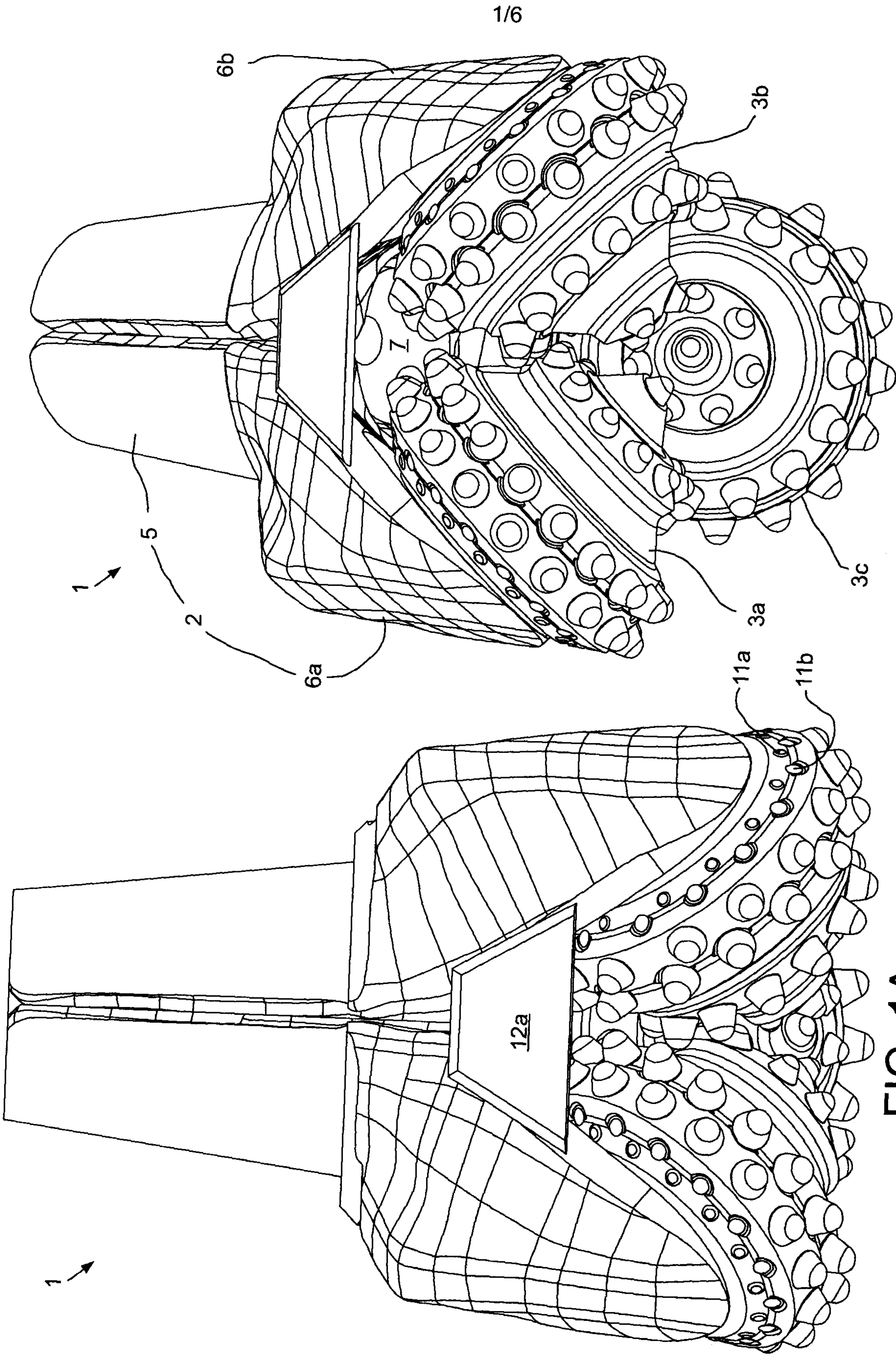

FIG. 1B

FIG. 1A

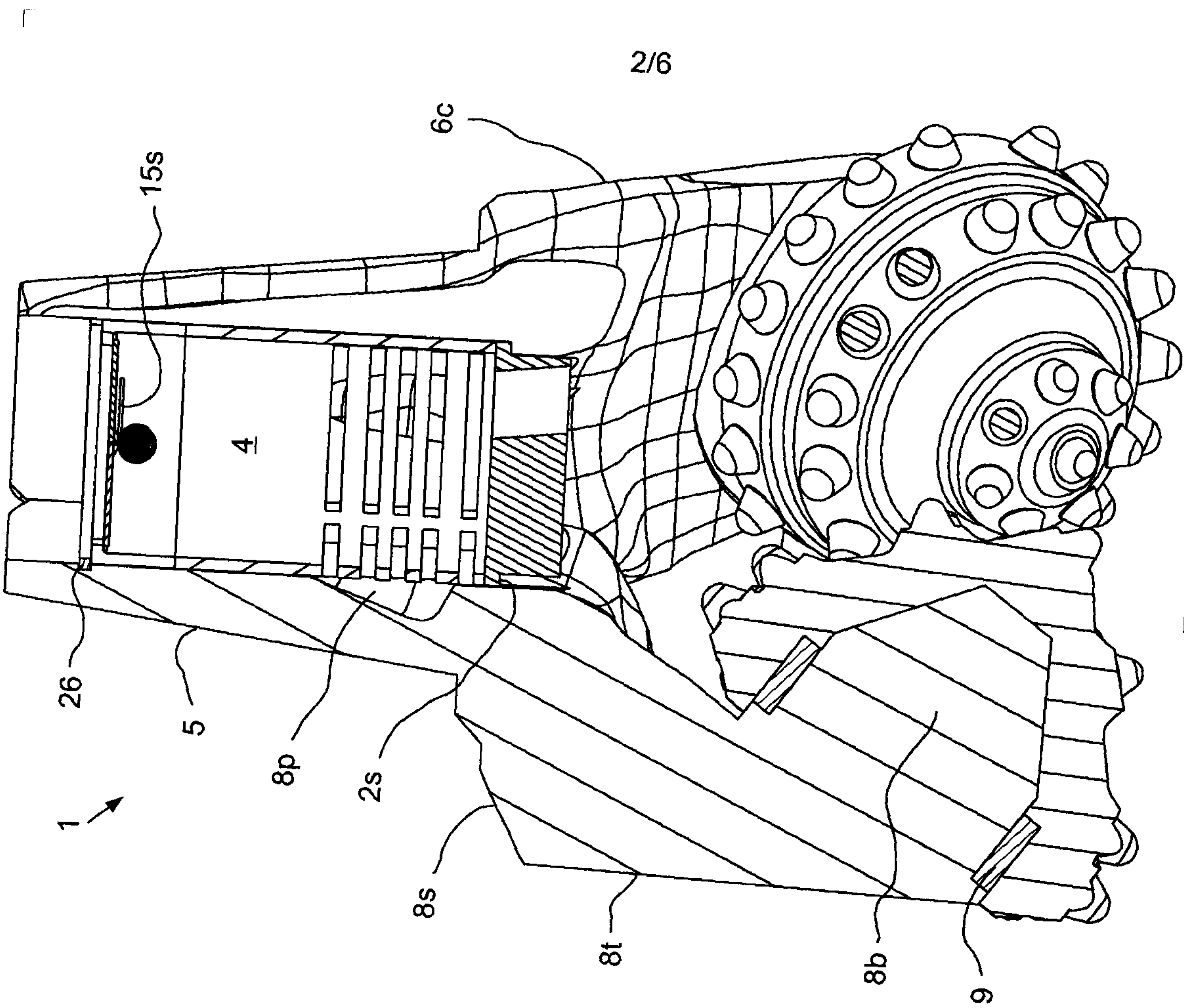

FIG. 2B

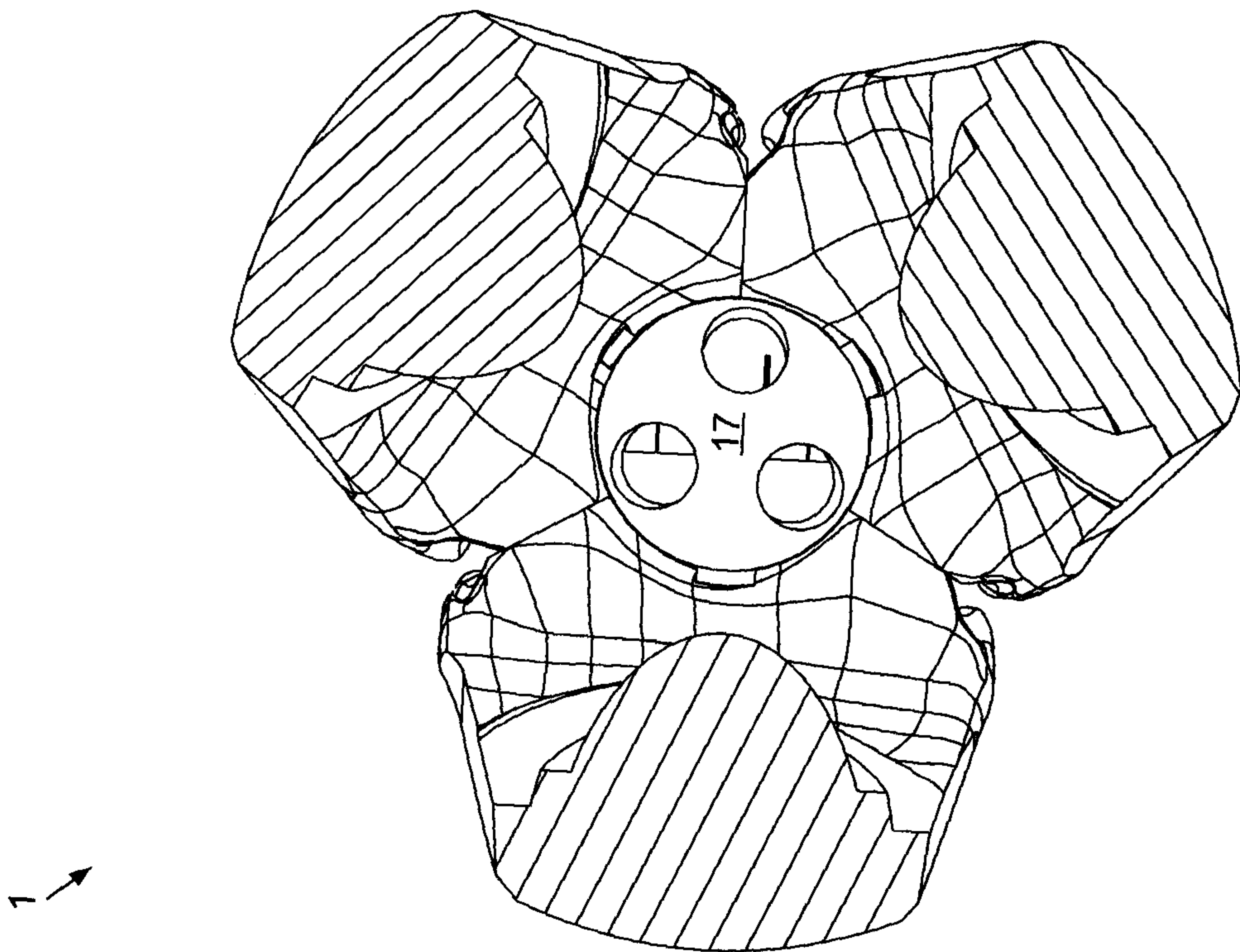

FIG. 2A

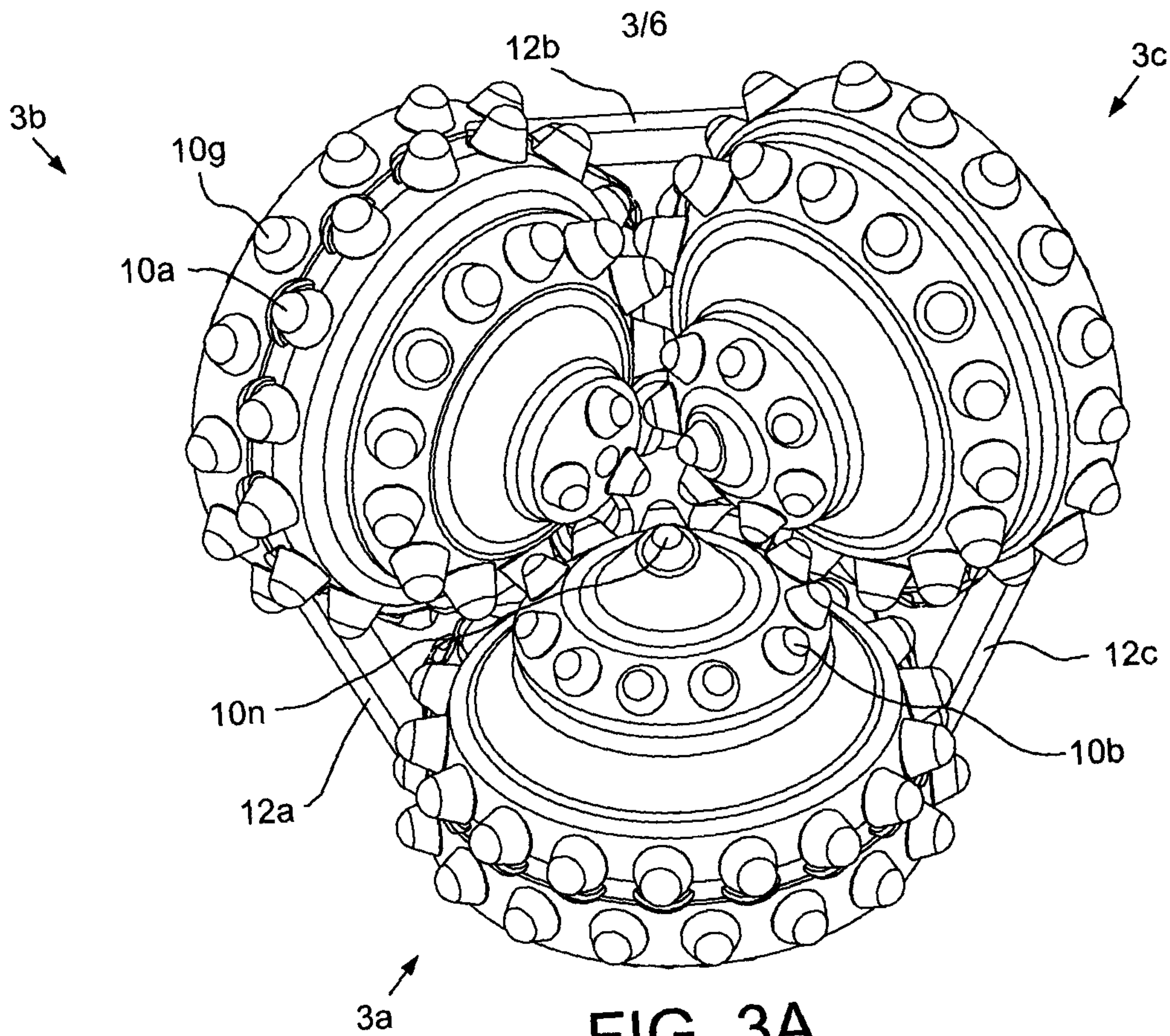

FIG. 3A

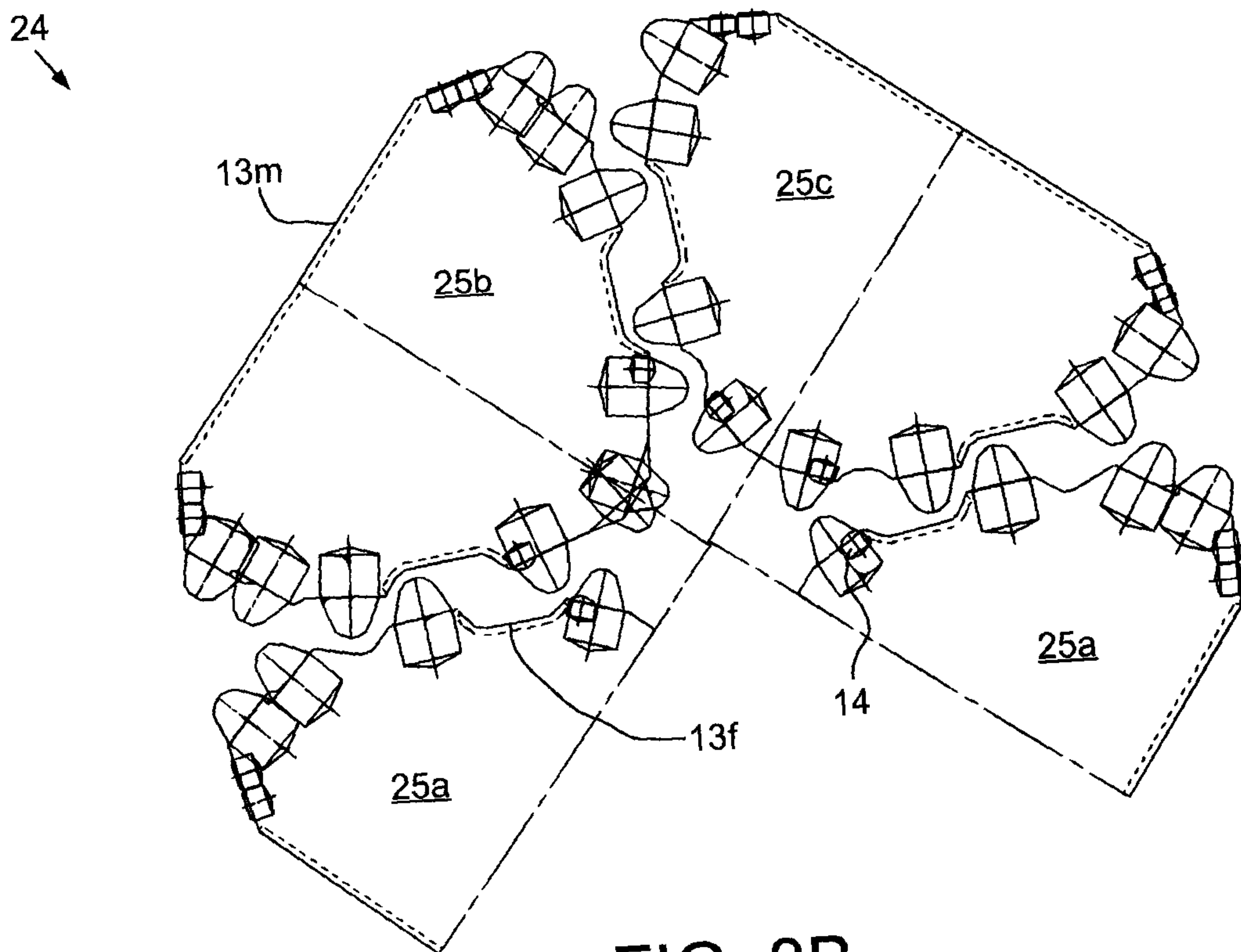

FIG. 3B

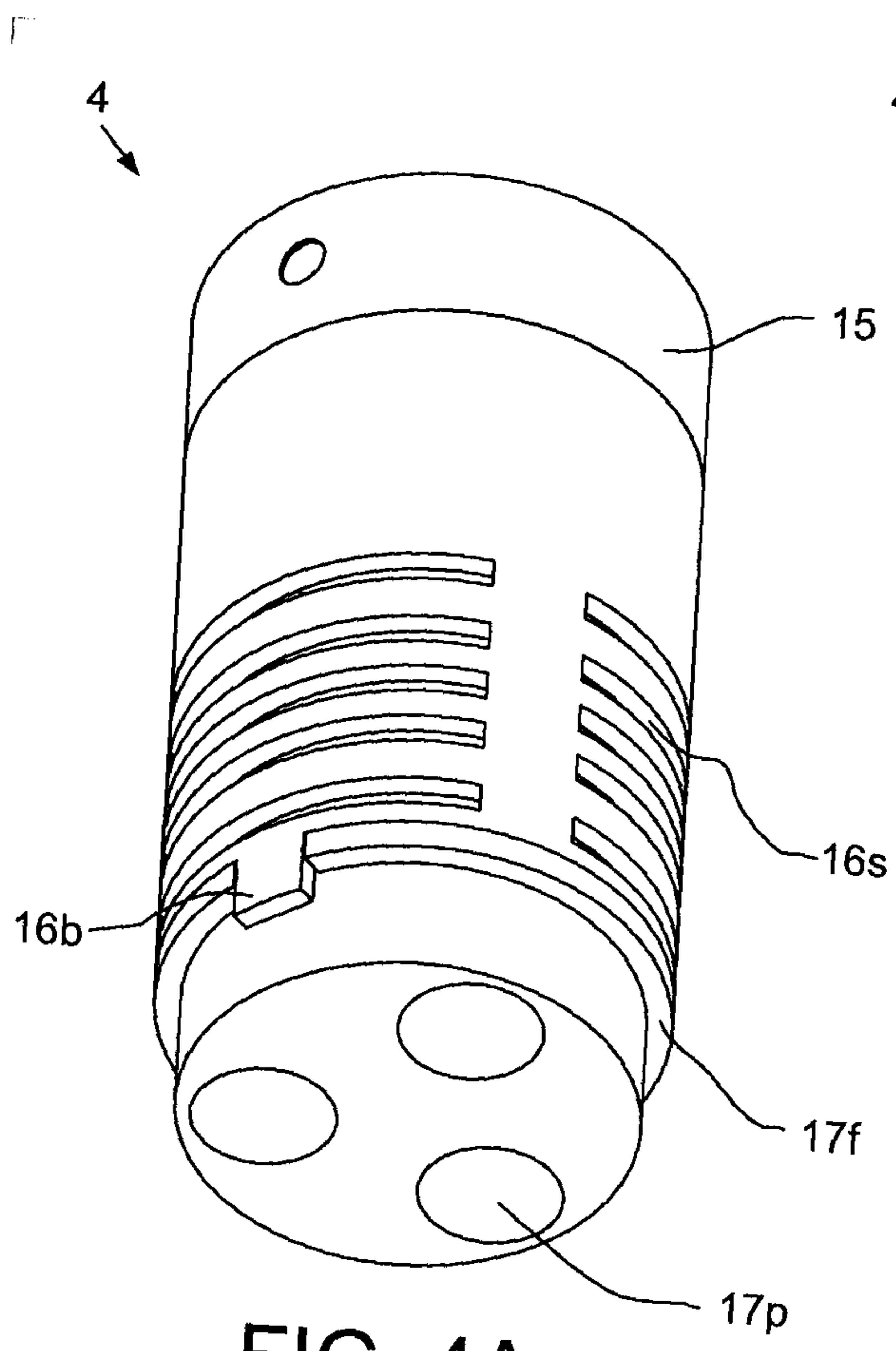

FIG. 4A

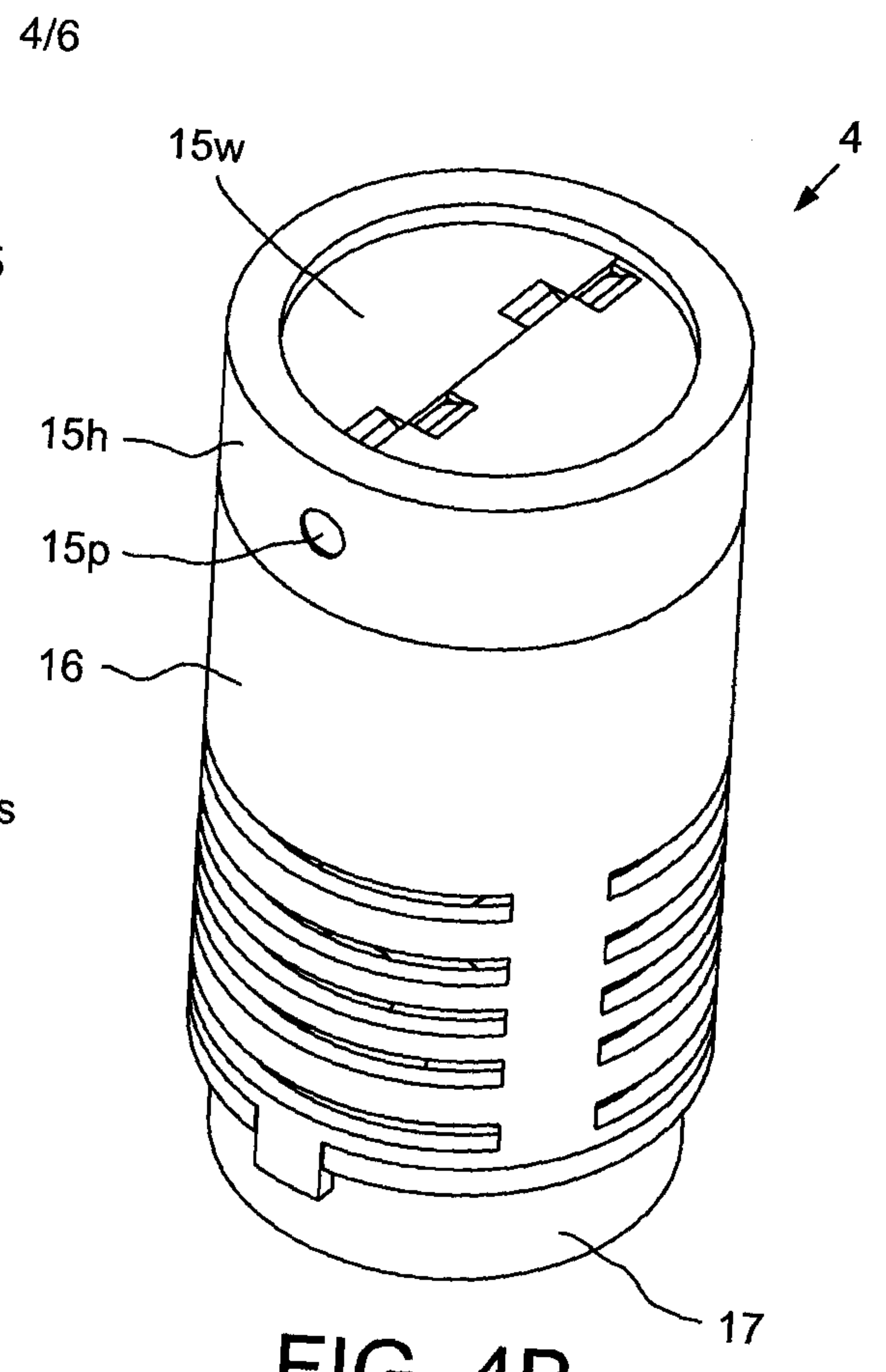

FIG. 4B

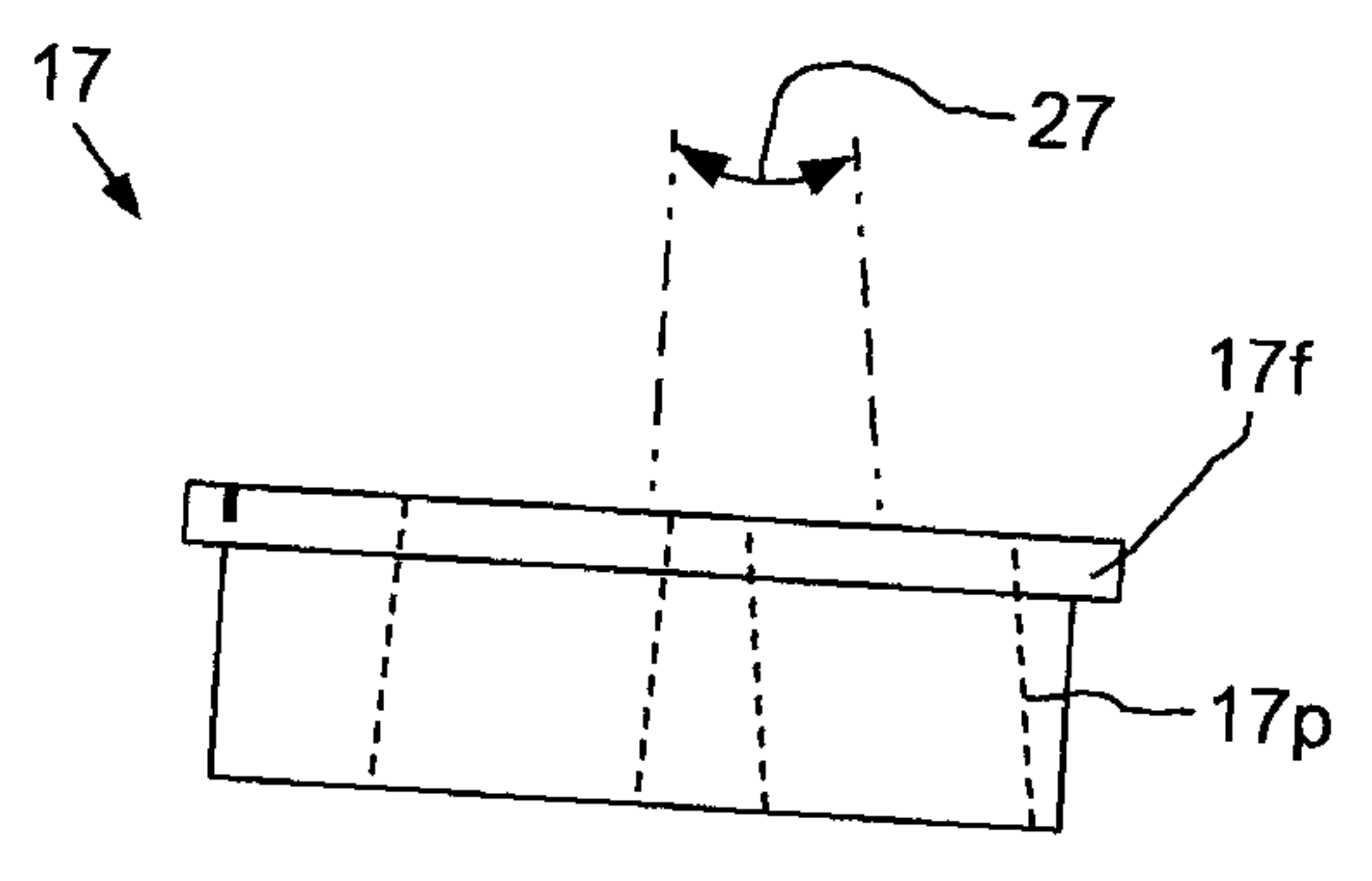

FIG. 4C

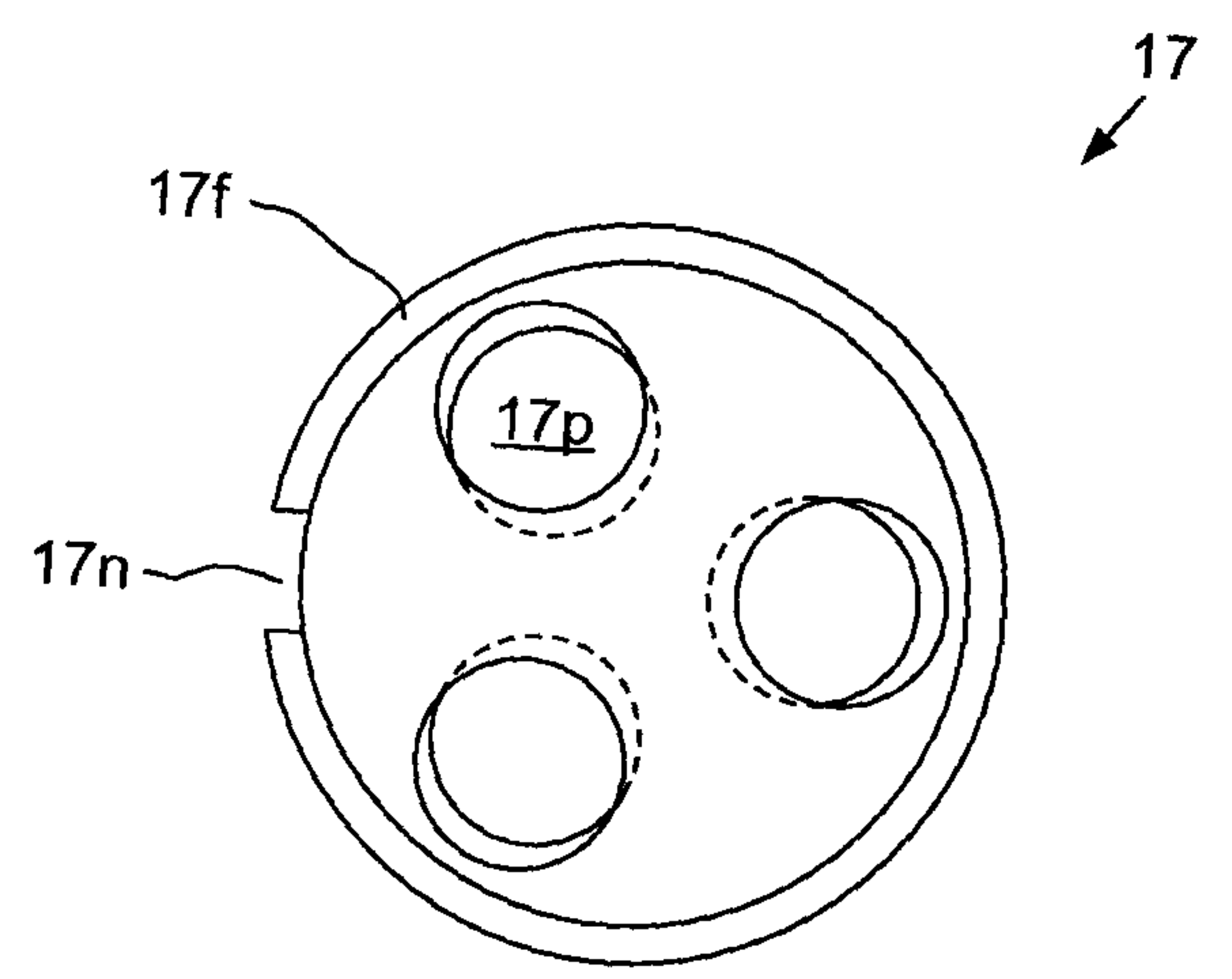

FIG. 4D

18

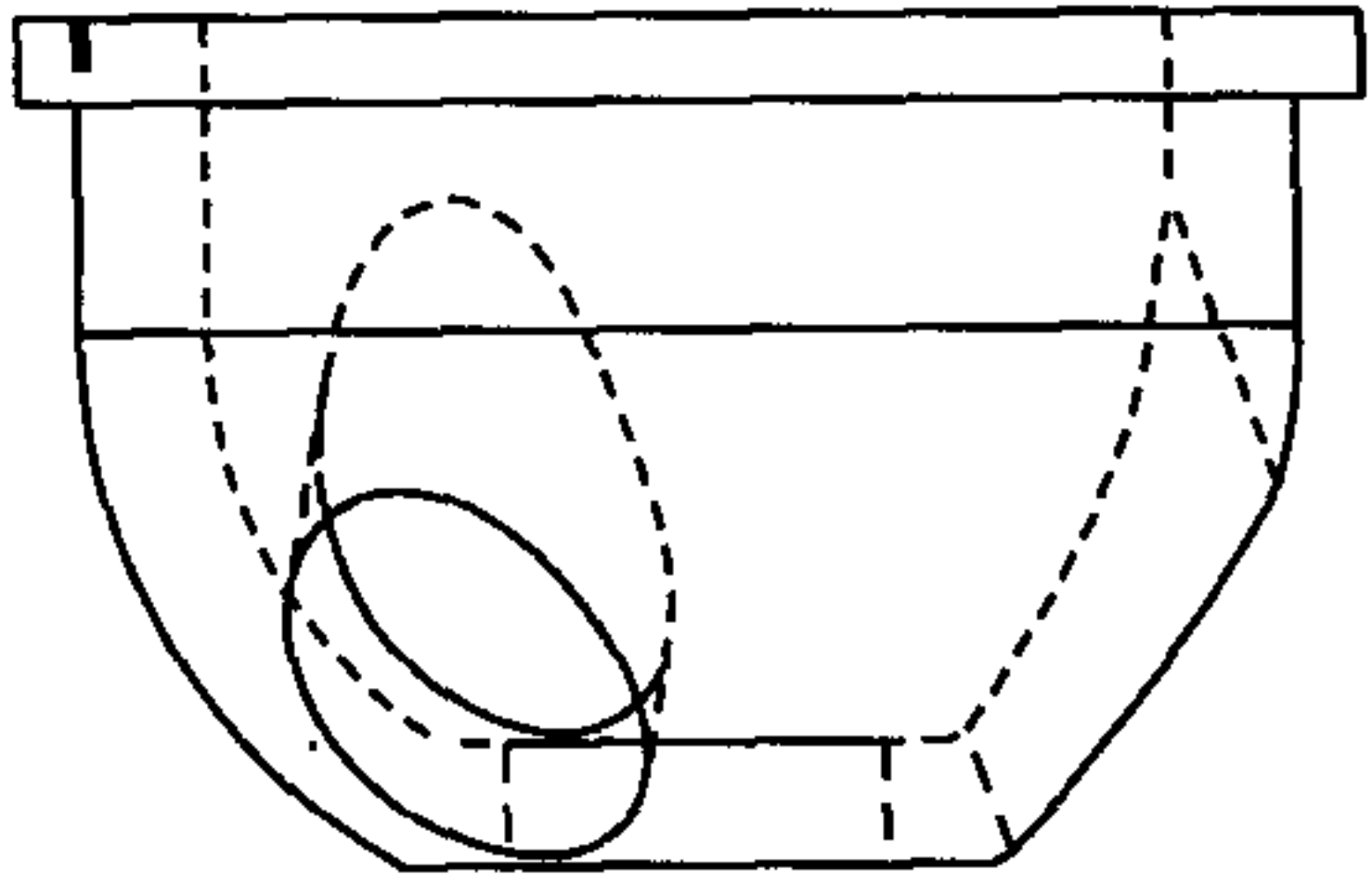

FIG. 5A

5/6

19

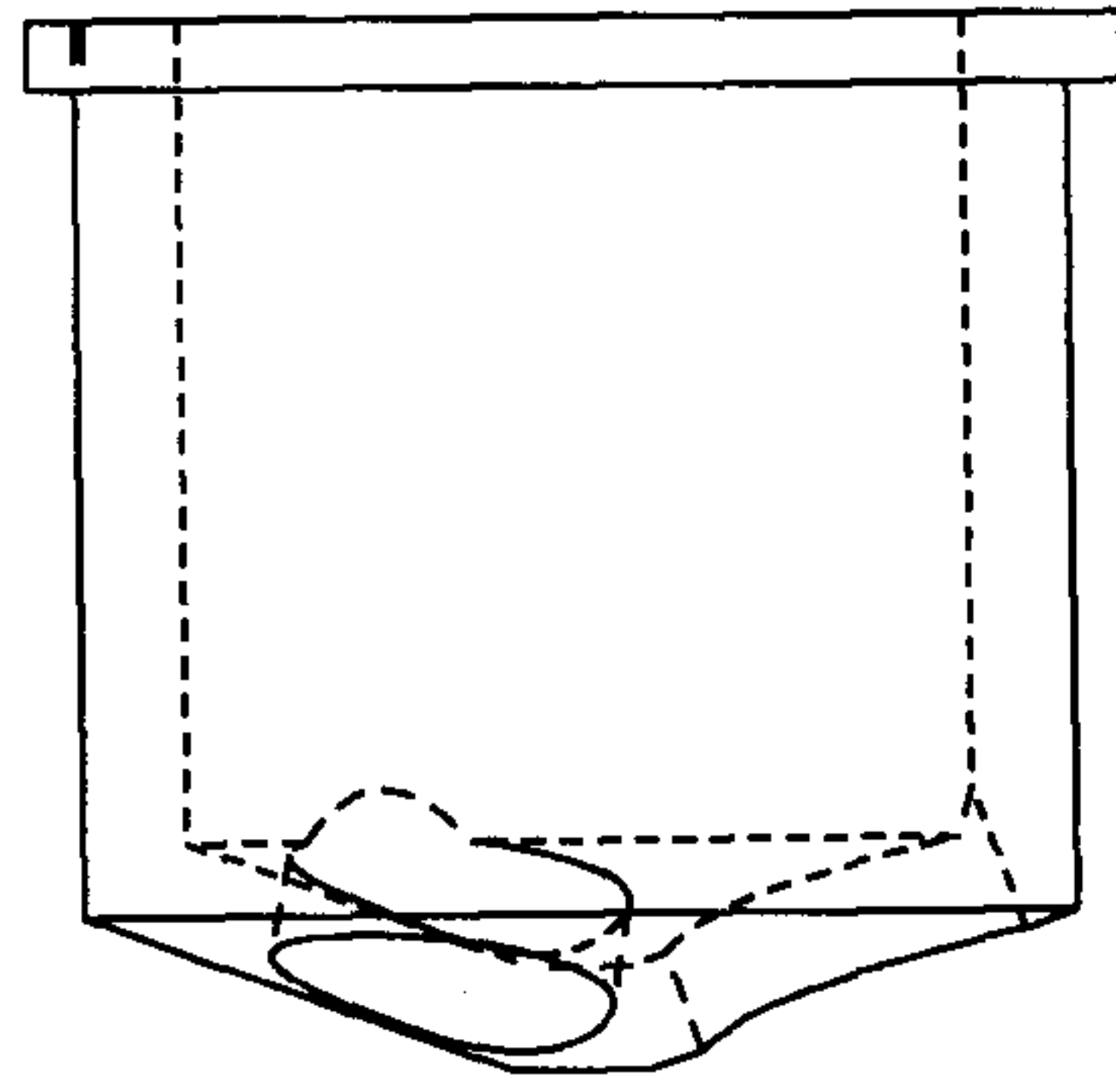

FIG. 5C

18

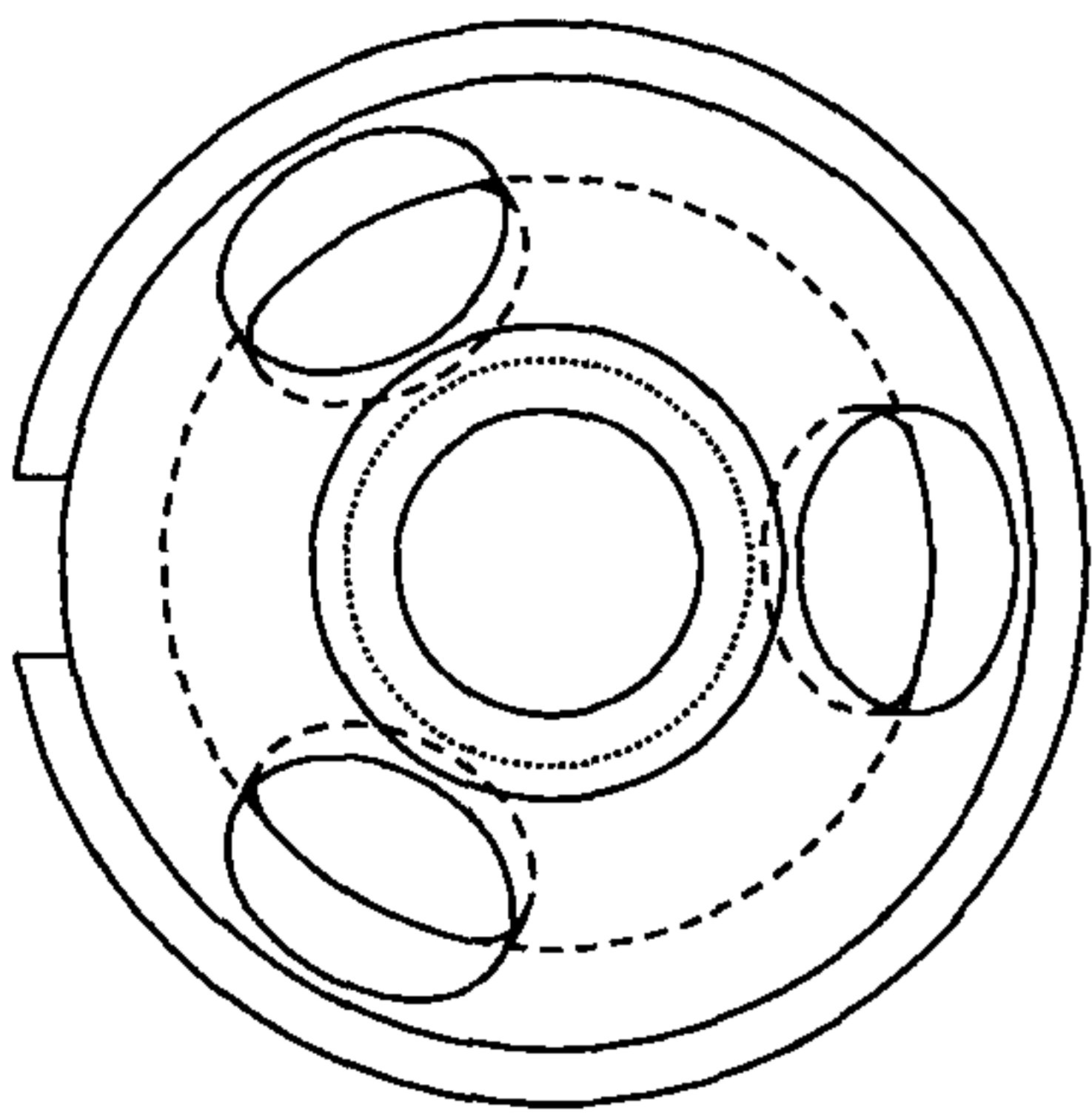

FIG. 5B

19

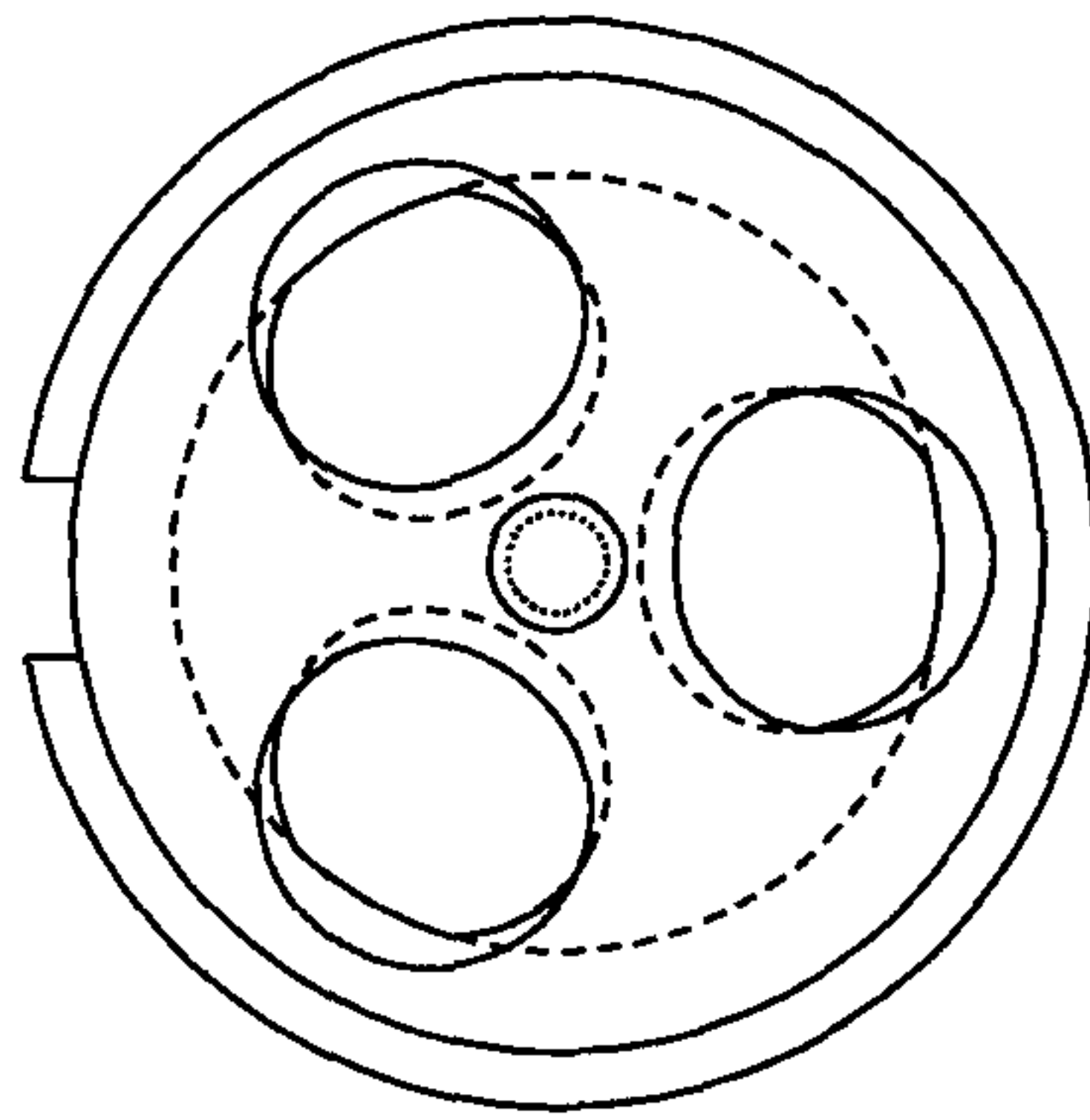

FIG. 5D

20

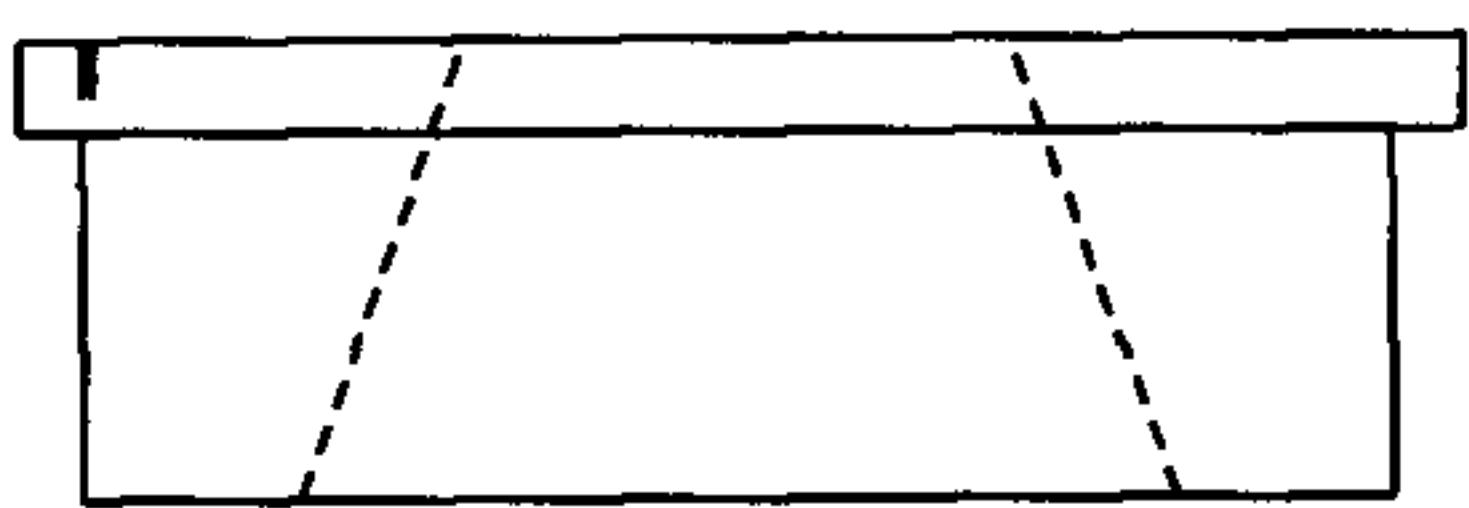

FIG. 5E

21

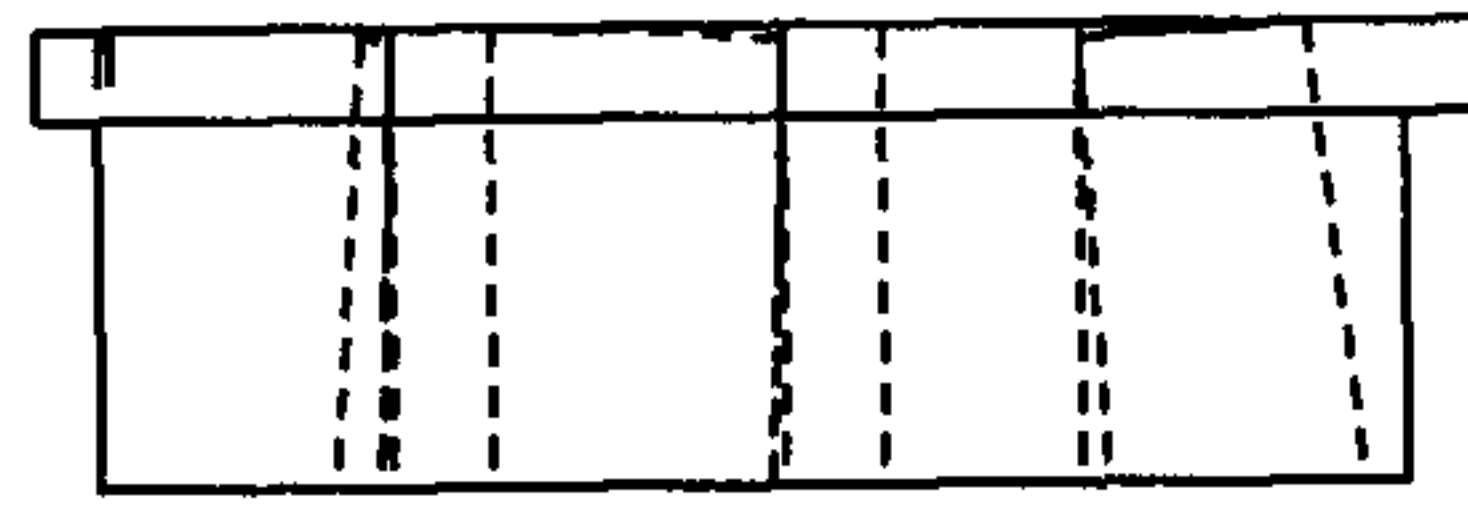

FIG. 5G

20

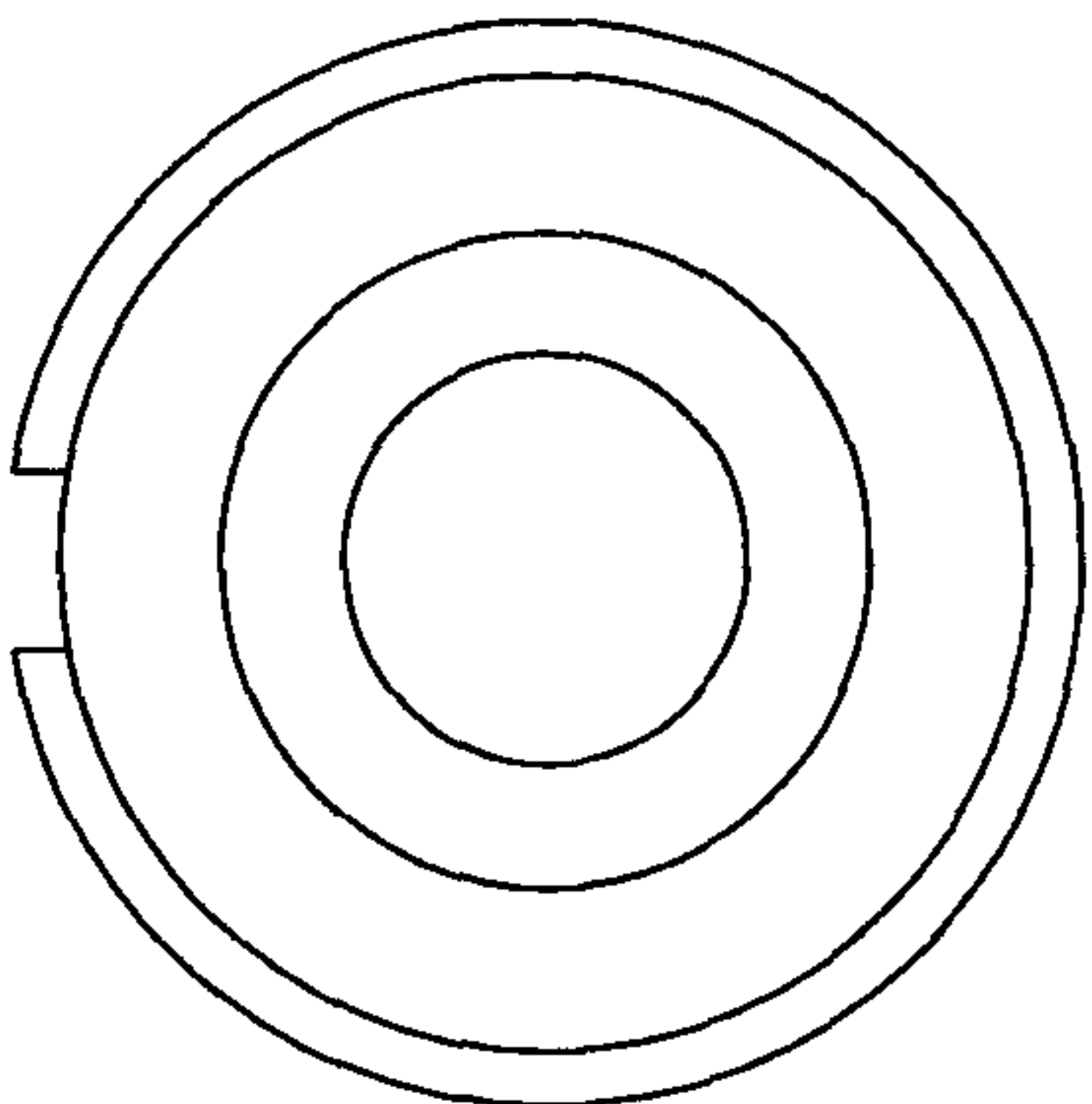

FIG. 5F

21

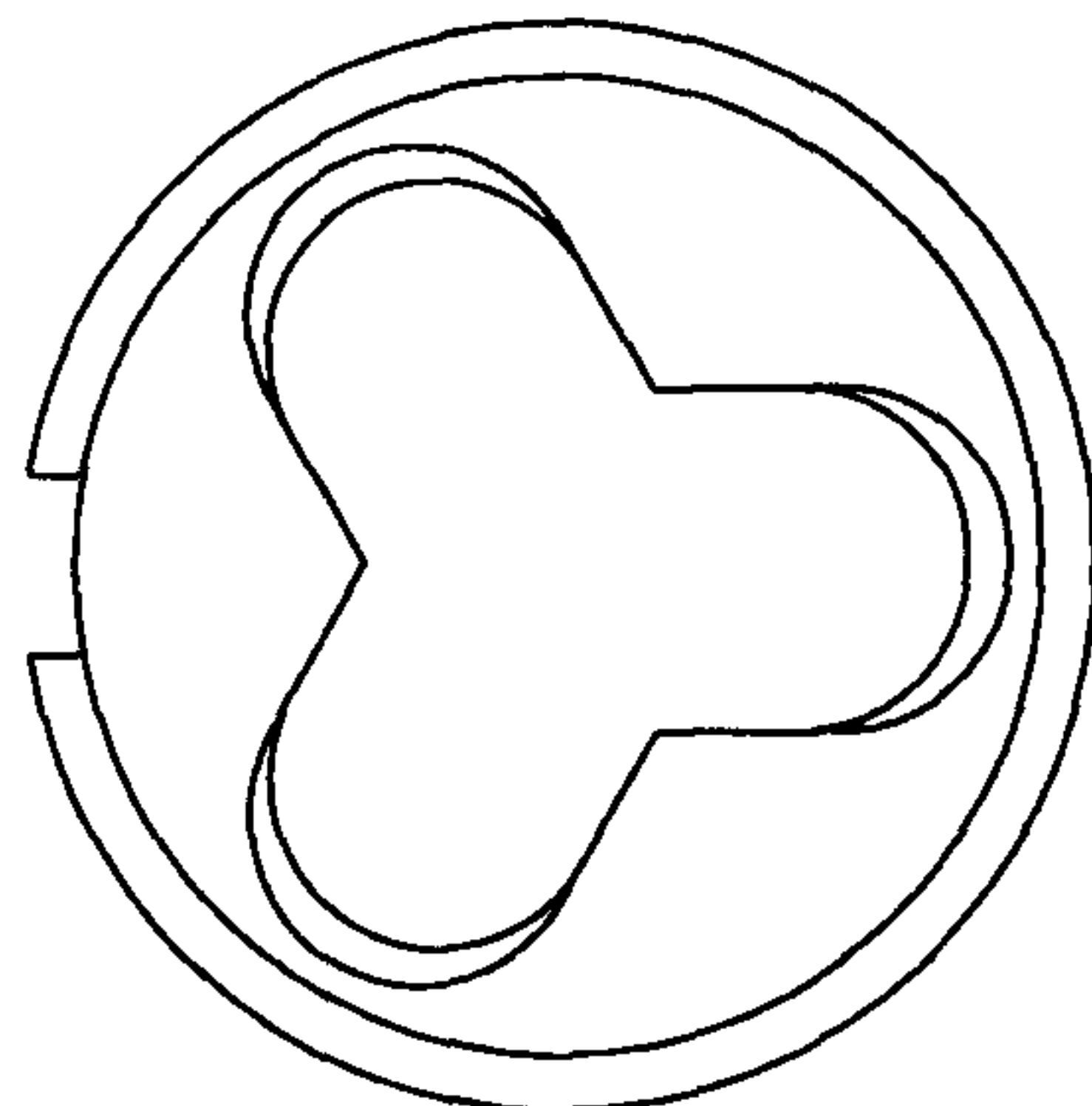

FIG. 5H

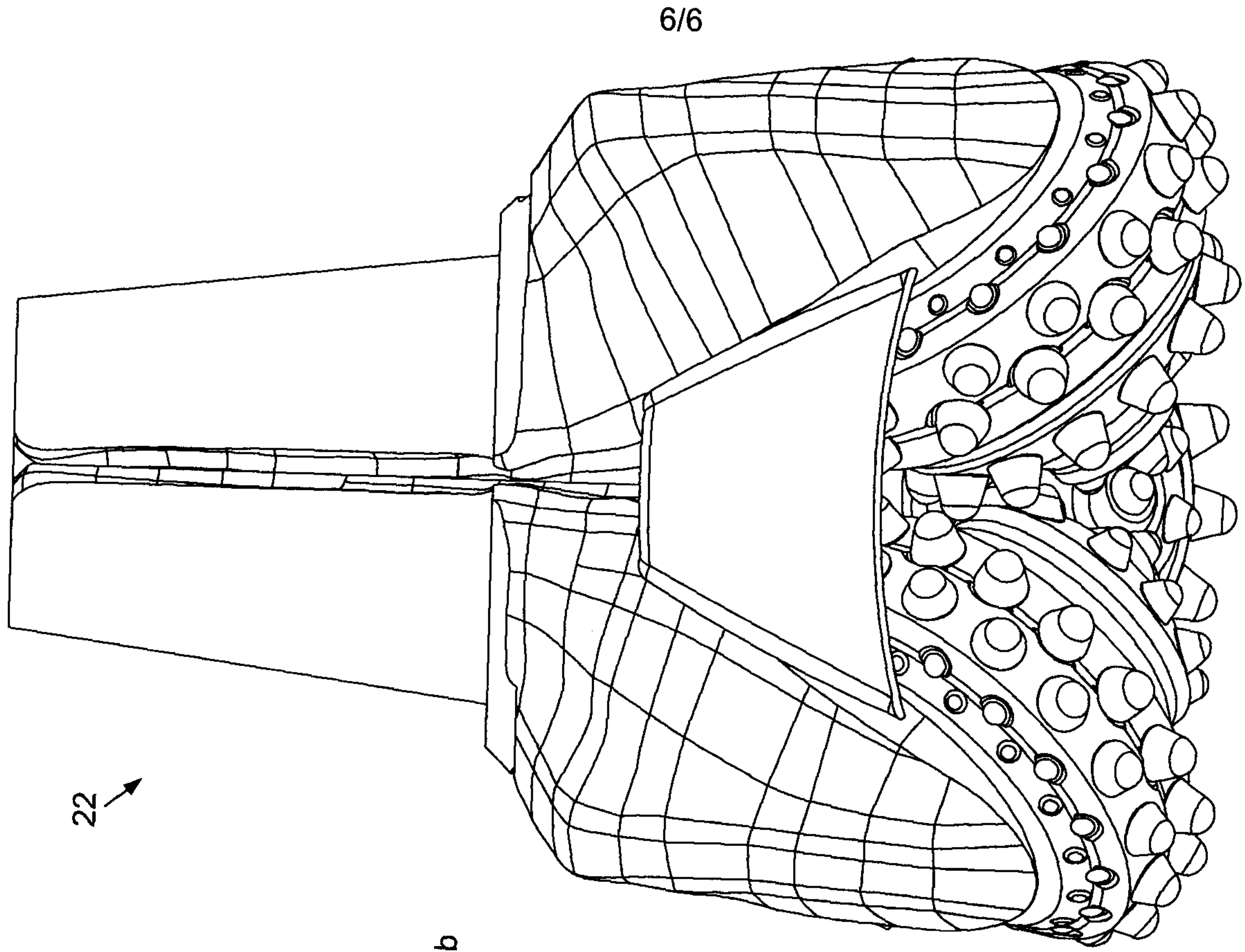

FIG. 6B

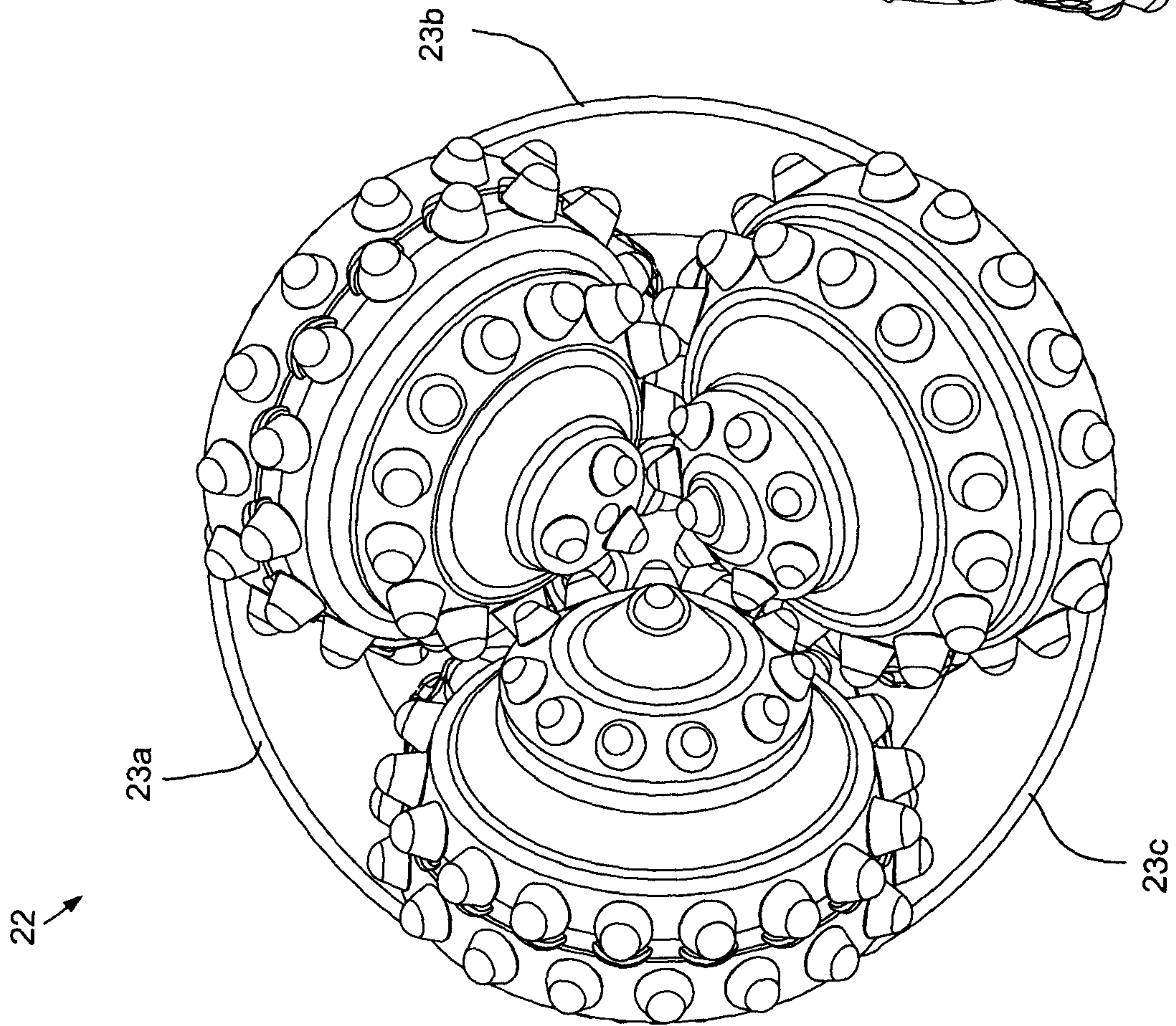
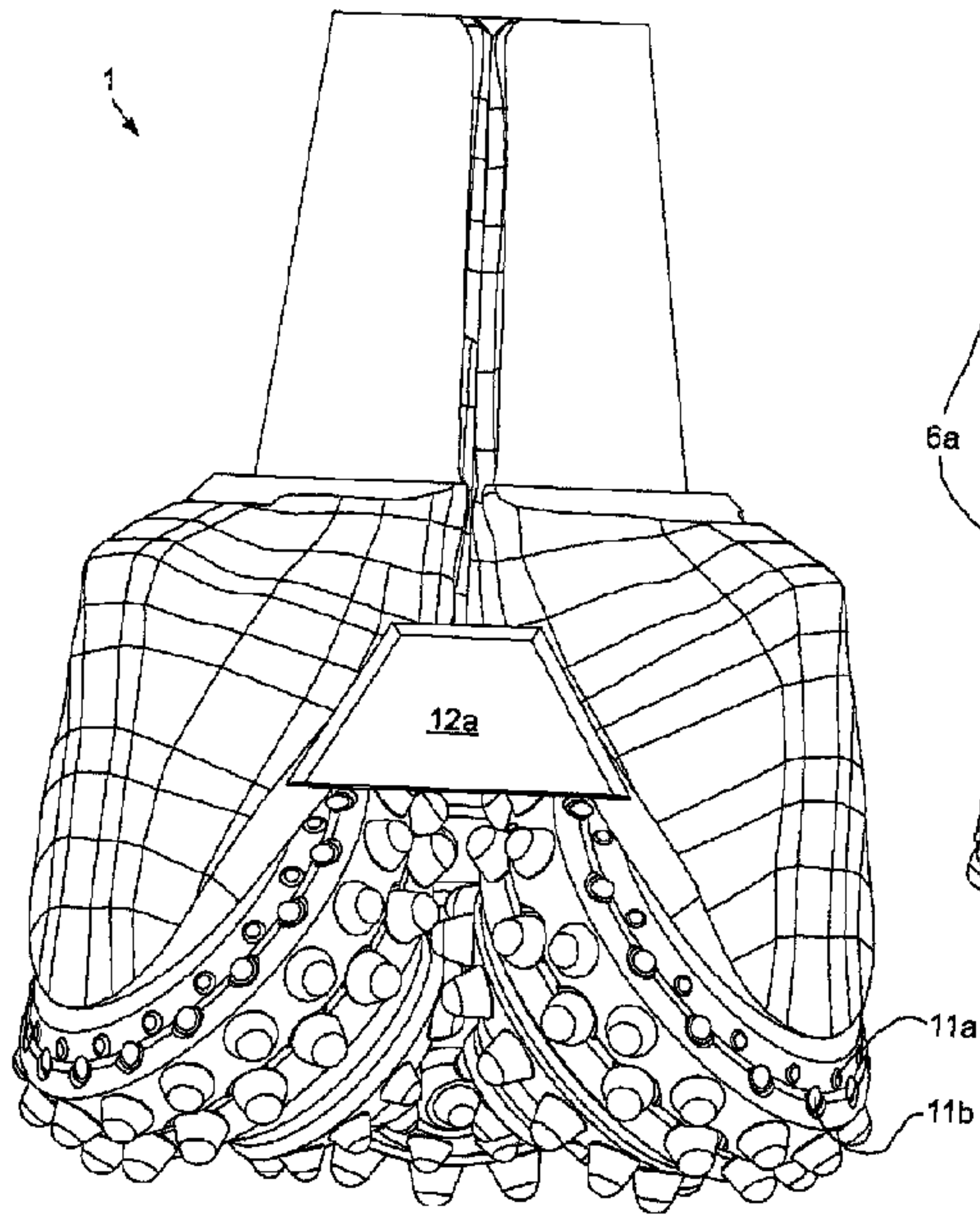
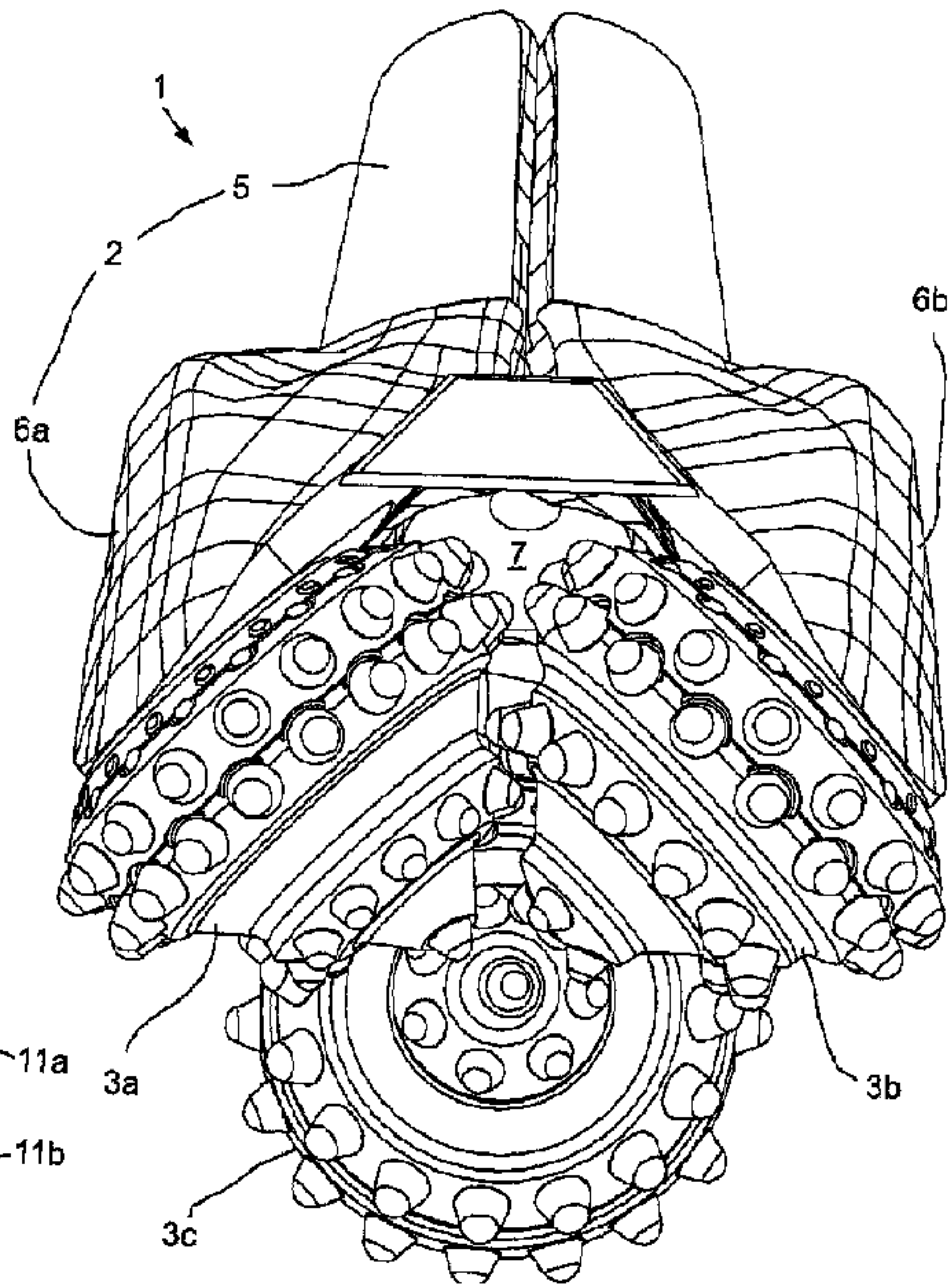

FIG. 6A

L



A



B