

(21) Application No: 0224413.5

(22) Date of Filing: 21.10.2002

(71) Applicant(s):
Peter Cook International Plc
(Incorporated in the United Kingdom)
Industrial Estate, Black Bourton Road,
CARTERTON, Oxon, OX18 3EU,
United Kingdom

(72) Inventor(s):
Dale Robertson

(74) Agent and/or Address for Service:
K R Bryer & Co
7 Gay Street, BATH, BA1 2PH,
United Kingdom

(51) INT CL⁷:
A47C 17/04 20/04

(52) UK CL (Edition W):
A4L LBRF

(56) Documents Cited:
GB 2066656 A **EP 0368540 A**
US 5790993 A **US 4589151 A**

(58) Field of Search:
UK CL (Edition V) **A4L LBHA LBHB LBHC LBRB LBRC**
LBRD LBRE LBRF
INT CL⁷ **A47C 17/04 20/04**
Other: **On-line: EPODOC, WPI, JAPIO**

(54) Abstract Title: **Articulated bed**

(57) The bed 10 comprises a divan type frame 12, 14 and a mattress support 15 made from a plurality of support panels 16, 18, 20, 22 which are pivotally connected and moved using actuators 42a to adjust the geometry of the bed. The pivot connection 24 between the frame and the panels may be located above the plane of the panels.

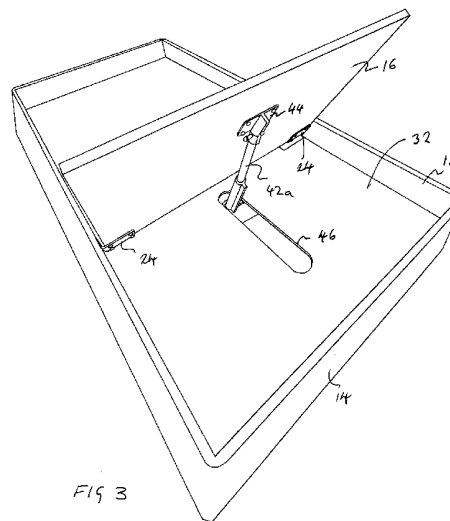
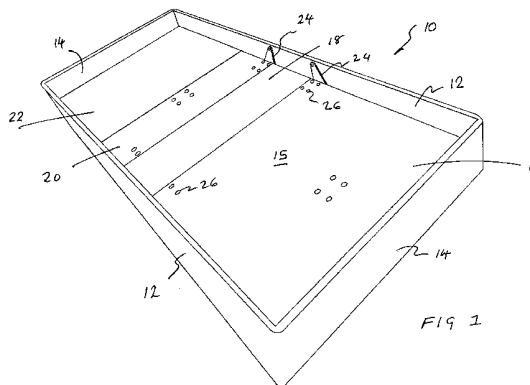

At least one drawing originally filed was informal and the print reproduced here is taken from a later filed formal copy.

This print takes account of replacement documents submitted after the date of filing to enable the application to comply with the formal requirements of the Patents Rules 1995

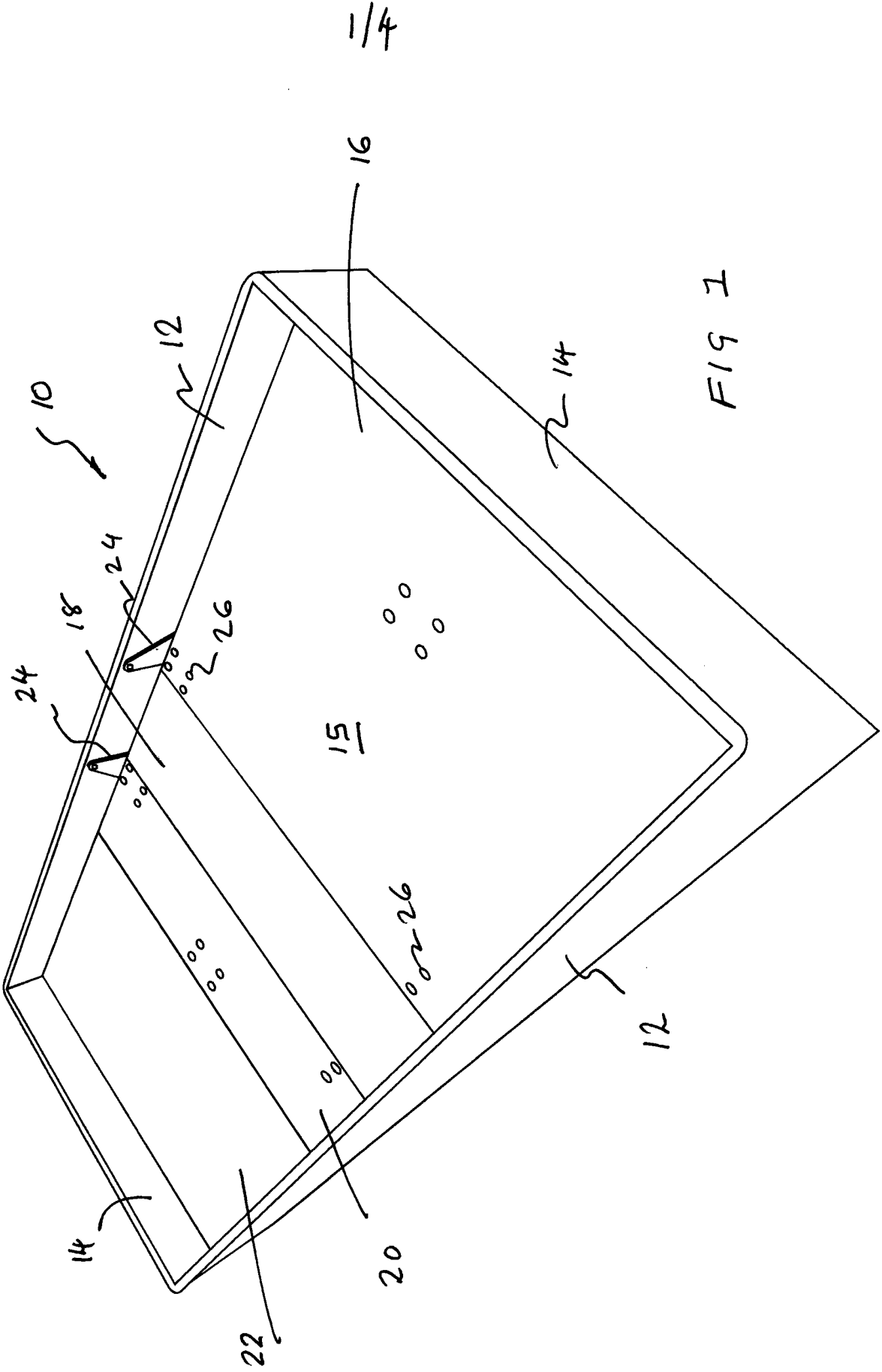

FIG 1

2/4

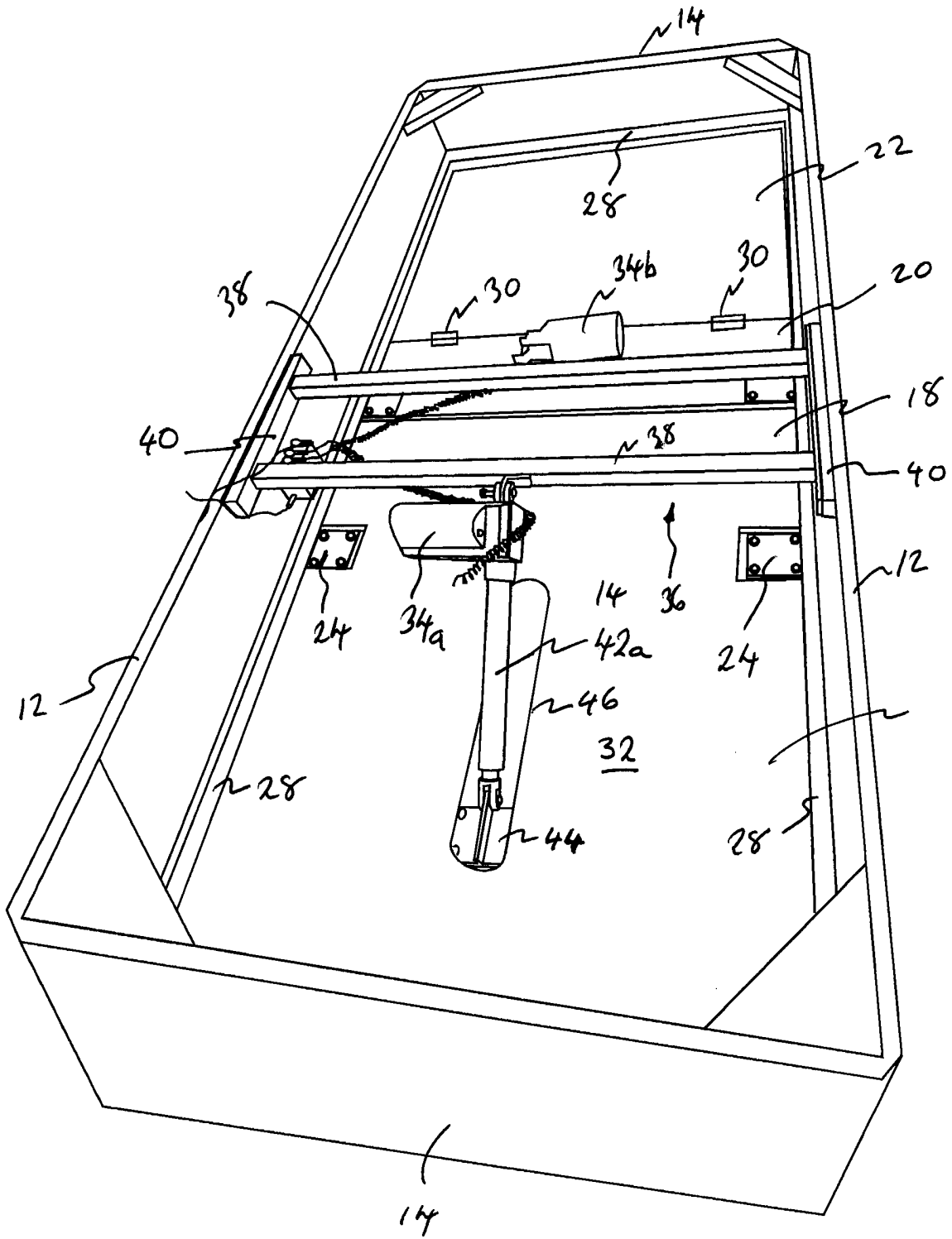

FIG 2

20 11 10

3/4

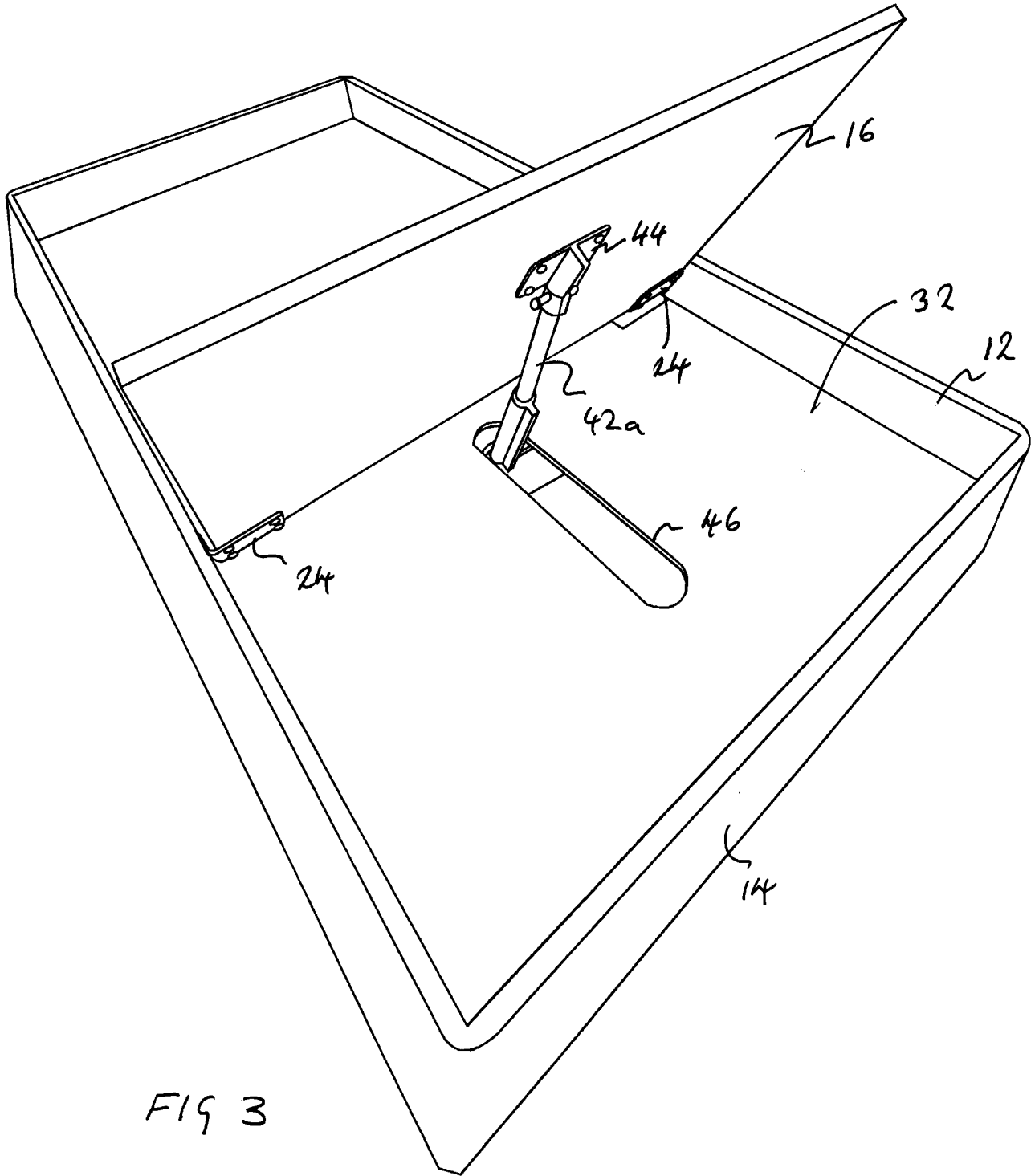
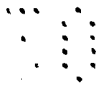
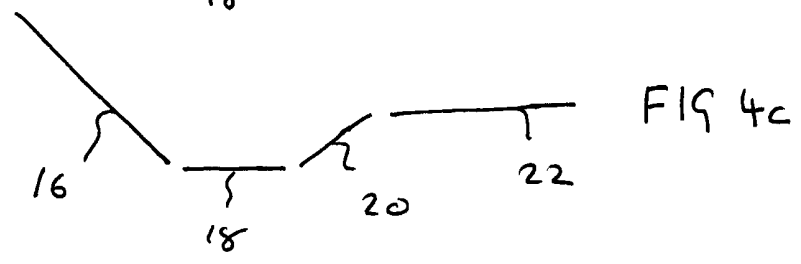
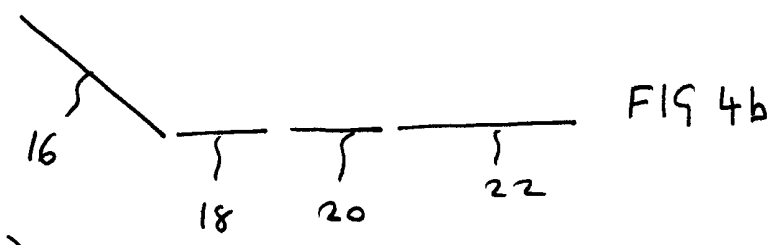
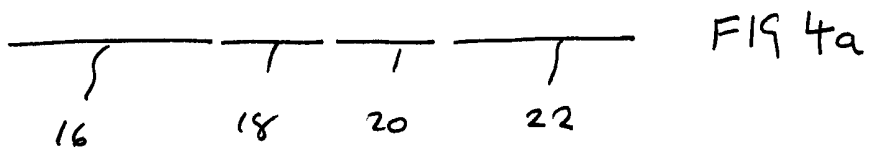

FIG 3



4/4



20 11 10

ARTICULATED BED

This invention relates to an articulated bed and in particular concerns an adjustable base for an articulated bed.

5

Articulated beds usually comprise four articulated mattress support sections which are pivotally connected together so that the geometry of the bed can be altered from a first configuration in which the sections lie substantially flat to provide a continuous flat platform for sleeping and a second configuration in which the sections are pivoted with respect to each other to provide a more upright geometry so that the user is provided with greater support when sitting in the bed.

In many known examples of articulating beds the mattress support comprises a lower body section which is fixed to a support frame of the articulating mechanism of the bed, an upper body section which is pivotally connected along its edge to an adjacent edge of the fixed lower body section, that is to say the upper body section is hinged to the fixed lower body section, an upper leg support section which is similarly hinged along a first edge to the fixed lower body section, and a lower leg support section which is hinged to the upper leg support section along its other side edge. Typical articulating mechanisms include a series of powered actuators, levers, links, and cams which operate to alter the configuration of the bed by moving the mattress support sections about the respective pivot axes. In known examples the actuating mechanisms are mounted on and/or within plinth type structures in which the mattress, and where appropriate mattress foundation, overhang the plinth. It is also known for

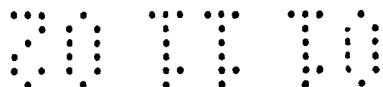

actuators to be mounted in a separate frame which is “dropped” into a typical divan surround. In other examples the actuating mechanisms are mounted on the underside of a typical metal bed frame between the corner legs thereof.

5 Articulating beds and their associated actuating mechanisms tend to be relatively complex structures which add appreciably to the cost and weight of the bed. This is due in part to the non-integrated structure of the actuating mechanism and bed which results in overly complex structures in which relatively heavy actuating mechanisms are provided for supporting the various adjustable sections of the mattress support. A
 10 relatively heavy and robust bed frame is then required for supporting the articulating mechanism. There is a requirement therefore for a more integrated articulated bed which is mechanically simpler in construction and having lower production costs than hitherto know arrangements.

15 According to an aspect of the invention there is provided a divan bed base for an articulated bed; the said base comprising a divan frame and a mattress support having at least one mattress support panel pivotally mounted with respect to the said frame, and actuator means for pivoting the said panel whereby to adjust the geometry of the bed.

20

This aspect of the invention provides a divan bed base which is adjustable between a first configuration in which the mattress support lies substantially flat for sleeping and a second configuration in which the mattress support panel(s) is/are pivoted for supporting a person on the bed in a reclined position. This aspect of the invention

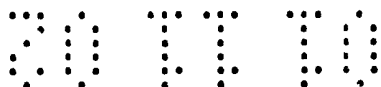

therefore provides an integral divan bed base which is adjustable for the purpose of providing a base for an articulated bed. In this way it is possible to support the mattress of an articulated bed using the frame of the divan base. For instance, in the configuration where the mattress support panel(s) is/are arranged substantially flat for sleeping the panel(s) can bear against load bearing features on the frame so that the panel(s) and the load acting thereon can be transferred directly to the frame of the divan base by engagement of the panel(s) with the support features on the base. In preferred embodiments, the inner periphery of the divan base is provided with a projecting rib for engagement with the support panel or panels along the respective edges thereof. The rib may further support a further intermediate support panel or panels between the rib and the lower surface of the mattress support panel or panels. In this way it is possible to support the mattress support panel(s) with respect to the divan base frame over the entire area of the panel(s) when lying substantially flat against the intermediate panel(s). In this configuration it is possible for the actuator means to act on the movable panel(s) through respective apertures in the intermediate support panel. The adjustable divan bed base according to this aspect of the invention thereby readily enables the mattress of an articulated bed to be supported on the divan frame substantially over the entire area of the mattress when the bed base is configured for sleeping. This can avoid the problems associated with an overhanging mattress, and secondary mattress or bed foundation, of known arrangements.

In preferred embodiments, the or each mattress support panel is pivotally connected to the frame. This readily enables the frame of the divan bed base to be used for supporting the support panel or panels. In this way it is possible to integrate the



articulating mechanism of an articulated bed into the frame of the bed base so that the articulating mechanism is enclosed within the base of a divan bed. This has the advantage that the moving parts of the articulating mechanism can be enclosed within the interior of an enclosed divan bed base.

5

Preferably, the mattress support panel(s) is/are pivotally connected to the frame about a (respective) pivot axis offset from the plane of the panel. This is advantageous in that it provides a gap between the edge of the panel and adjacent structure when the panel is moved about its pivot axis during adjustment of the base. This can avoid sharp discontinuities in the contour of the mattress support and by so doing avoid “pinching” of the mattress or mattress sections that is/are in contact with the mattress support panel in the region of the edge of the panel when it is pivoted. Where the mattress panels are provided with sprung or foam based elements the offset hinge removes the risk of the elements crushing each other.

15

In preferred embodiments, the pivot axis is offset above the panel in a mattress receiving area of the divan bed base.

Preferably, the actuator means is located in a region below the mattress support on the opposite side of the mattress support to the mattress side of the base. This readily enables the actuator means to be enclosed within the base so that the base provides a housing for the actuator and guards against damage thereof due to interference with other objects.

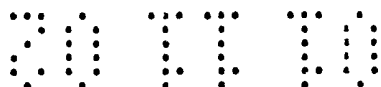

Preferably, the actuator means is fixed with respect to the frame of the base and connected to the support panel for movement of the panel with respect to the frame. In this way it is possible to utilise the frame for the divan bed base to provide a support structure for the reaction of the loads applied to the support panel(s) by the actuator means. By using the frame in this way it is possible to provide a relatively simple, strong, robust and inexpensive lightweight adjustable base for an articulated bed.

Preferably, the side edges of the mattress support panel are substantially flush with side panels of the divan bed base frame. This can enable the divan bed base frame to be substantially the same size of the mattress that it is to support, and in arrangements where the side panels project above the mattress support the side panels can prevent movement of the mattress with respect to the frame when positioned on the mattress support.

In preferred embodiments, the mattress support comprises a first support panel fixed with respect to the frame, a second support panel pivotally mounted with respect to the frame on one side of the said first panel and second support panel pivotally mounted with respect to the frame on the opposite side of the said first panel, whereby the said first, second and third panels provide an adjustable mattress support surface. This arrangement readily enables the divan bed base according to the above aspect of the invention to be adjusted from a substantially flat configuration for sleeping to a configuration in which the second support panel is inclined with respect to the first support panel to provide an incline upper body support section with the third support

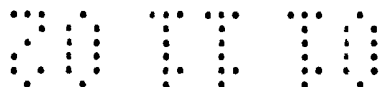

panel inclined in the opposite direction with respect to the first panel to provide a raised leg support section.

In preferred embodiments, the actuator means comprises a pair of actuator for
 5 independently moving the pivotally mounted support panels about their pivot axes. In
 this way the divan base may be adjusted to provide a mattress support having an
 inclined upper body support configuration, an inclined upper leg support configuration
 or both in accordance with the movement of the panels by the separate actuators.
 Preferably, the actuators are linear actuators with each actuators having a moveable
 10 ram with one end of the ram connected to an underside of a respective panel. In
 preferred embodiments the actuators are mounted on a support member which extends
 between the sides of the divan base at an intermediate point between the two end
 panels of the base. In this arrangement the actuators are readily supported by the
 divan bed base of this aspect of the invention.

15

In preferred embodiments, the mattress support comprises a fourth support panel
 which is pivotally mounted in back to back relation with the third support panel along
 the side edge of the third panel opposite the side edge adjacent to the first fixed panel.

20 In another aspect the invention also comprehends a bed including a divan base
 according to the aforementioned first aspect of the invention.

The invention further comprehends a kit of parts for a divan base according to the
 above first mentioned aspect of the invention.

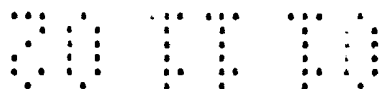

An embodiment of the present invention will now be more particularly described, by way of example, with reference to the accompanying drawings, in which;

Figure 1 is a perspective view of the top of a divan bed base according to an
5 arrangement of the present invention;

Figure 2 is a perspective view of the underside of the divan bed base shown in Figure 1;

Figure 3 is a perspective view similar to that of Figure 1 with the base adjusted by pivotal movement of a mattress support panel to the inclined position shown;

10 Figure 4a is a schematic representation of the bed of the Figures 1-3 shown in a flat bed sleeping configuration;

Figure 4b is schematic representation similar to that of Figure 4a with the upper body support section inclined;

15 Figure 4c is a schematic representation similar to Figures 4a and 4b with the leg support sections inclined in addition to the upper body section.

Referring to Figure 1, an adjustable divan bed base for an articulated bed is indicated generally at 10. The divan base comprises a pair of parallel side panels 12 which are connected together at their respective ends by parallel end panels 14 to provide a
20 generally rectangular box frame structure. The panels 12, 14 may be joined together by any conventional means such as bolts or screws with or without adhesive or may be joined in accordance with the arrangement described in GB patent application 0218894.4 the contents of which are incorporated herein by reference. The panels may be constructed of any suitable material including for example MDF or other resin

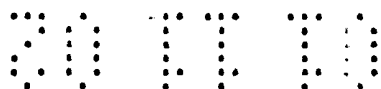

bonded fibre board suitable for the purpose of providing a load bearing structure. The outward facing surfaces of the panels may be upholstered or coated with any suitable coating or covering material such as a wood effect grain or covered with a veneer or hard wearing laminate sheet material depending on the decorative effect required.

5

The interior region 15 of the bed base, the boundary of which is defined by the side and end panels 12, 14, is provided with four mattress support panels 16, 18, 20, 22 arranged side by side in series to provide an upward facing mattress support surface having substantially the same size and shape as the rectangular frame provided by the side and end panels 12,14 and the mattress to be supported (not show) on the base.

10

The support panels 16, 18, 20, 22 are arranged parallel with respect to each other extending from one side panel 12 to the other such that the edges of the support panels are parallel to the side panels 12 and lie substantially flush against the inward facing surface of the panels 12 typically with a gap of a few mm between the support panels and the side panels to allow pivoting of the support panels in a manner to be described.

15

The support panels 16, 18, 20, 22 and side and end panels 12, 14 provide a tray type structure for receiving a mattress or sprung or foam based mattress support elements (not shown) on top of the panels 16, 18, 20, 22 within the region defined by the side and end panels panels 12, 14.

20

The support panels 16, 18, 20, 22 have substantially different width dimensions in the longitudinal direction of the frame. The first panel 16 has a width dimension (in the

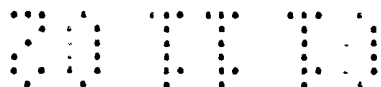

longitudinal direction of the frame) which is substantially half that of the length of the frame. For example, the width of the panel may be 945mm when the longitudinal dimension of the frame is 1960mm. The support panel 16 is pivotally connected to the frame side panels 12 along a pivot axis parallel with and in the region of the edge of the panel 16 adjacent to the neighbouring panel 18. The panel 16 is pivotally connected to the side panels 12 by a pair of L-shaped brackets 24 secured to the under-surface of the panel 16 by fastening means in the form of bolts or screws 26. The brackets 24 are secured at the respective hinged corners of the panel 16 adjacent to the panel 18 and pivotally mounted on the inward facing surfaces of the respective side panels (as best seen in Figures 2 and 3). The second panel 18 is smaller than the neighbouring panel 16 and may have a width dimension of 280mm in the longitudinal direction of the frame. A clearance of a few mm is provided between the panels 16 and 18. The support panel 18 is fixed to the side panels 12 of the frame by engagement with an inwardly projecting rib 28 (best seen in Figure 2) extending around the inner periphery of the frame on the underside of the support panels 16, 18, 20, 22.

The support panel 20 located between the fixed panel 16 and the panel 22 has a width dimension similar to that of the fixed panel 18 in the longitudinal direction of the base. The panel 20 is pivotally mounted to the side panels 12 by means of L-shaped brackets 24 in substantially the same way that the support panel 16 is mounted. A clearance of a few mm is provided between the edges of the adjacent panels 18 and 20 to avoid interference during pivoting.

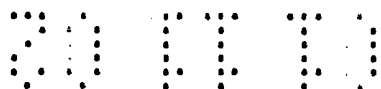

The final panel 22 is pivotally connected to the panel 20 along the adjoining edges of the panels 20, 22 by means of hinges 30 (see Figure 2) positioned on the underside of the respective panels.

5 In the adjustable divan bed base of the present invention the mattress support panel 16 constitutes an upper body support panel, the support panel 18 constitutes a lower body support panel, the support panel 20 constitutes an upper leg or thigh support panel and the support panel 14 constitutes a lower leg support. In the configuration shown in Figure 1 the panels 16, 18, 20,22 lie substantially flat to provide a flat surface on
10 which a mattress can be supported on the mattress support panels within the region surrounded by the side and end panels of the frame.

Referring now to Figure 2, in the configuration shown in Figure 1 the mattress support panels 16, 18, 20, 22 are supported by the rib 28 projecting from the inward facing
15 side of the side and end panels around the periphery of the frame. This enables the weight supported by the mattress support panels to be transferred directly to the divan bed base frame. The edges of the mattress support panels 18, 20,22 which extend around the inner periphery of the frame are engaged by the rib when in the configuration shown in Figures 1 and 2. The support panel 16 is supported
20 substantially over its entire area by engagement with an intermediate support panel 32 which is fixed in relation to the frame by engagement with the rib 28 in the region of the panel 16. The intermediate support panel 32 can best be seen in the view of Figure 3 where the support panel 26 is pivoted to an inclined position.

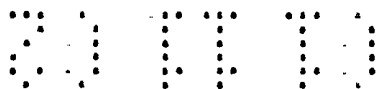

A pair of linear actuators 34a, 34b are provided for moving the respective mattress support panels 16, 20 about their pivot axis. The actuators are ram type extension actuators powered by stepper motors or the like with the actuators mounted on a sub frame 36 comprising a pair of parallel spaced box-section tubes 38 joined at their

5 respective ends by parallel end plates 40 which are disposed perpendicular to the longitudinal direction of the tubes 38. The sub-frame 36 extends between the side panels of the frame on the underside thereof at an intermediate position between the end panel 14 with the end plates 40 being fixed to the inward facing sides of the side panels in the region underneath the fixed support panel 18. The ram 42a of the

10 actuator 34a is connected at one end to a mounting bracket 44 on the underside of the panel 16. An aperture in the form of a slot 46 is provided in the intermediate panel 32 for movement of the actuator ram 42a through the panel 32 when moving the support panel 16 to its inclined position shown in Figure 3. The actuator 34b is similar to that of 34a except that the end of the ram 42b is connected directly to the underside of the

15 support panel 20.

In use, energisation of the actuators 34a, 24b is capable of adjusting the geometry of the mattress support between the positions shown in Figures 4a, 4b, 4c. In the position shown in Figure 4a the actuators are not energised and the panels 16, 18, 20,

20 22 lie substantially flat and are supported of the rib 28. In the position shown in Figure 4b the panel 16 is raised to the inclined position shown in Figure 3 by energisation of the actuator 34a. Movement of the panel 16 to this position has the effect of raising a substantial part of the mattress (not shown) to the inclined position shown to provide an angled configuration suitable for supporting a person on the bed

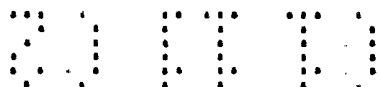

in a reclined position. In the position shown in Figure 4c the mattress support panel 20 is moved to its inclined position by activation of the linear actuator 32b. The inclination of the mattress support panel 20 is opposite to that of the support panel 16 and this provides a suitable raised an inclined geometry for supporting the users upper
 5 and lower legs. In the configuration of Figure 4c the mattress support panel 22 hinges with respect to the panel 20 to provide a gently sloping inclined surface for the users lower legs.

Although aspects of the invention have been described with reference to the
 10 embodiment shown in the accompanying drawings it is to understood that the invention in not limited to this precise embodiment and that there is changes and modifications may be effected without exercise of the further inventive skill and effort. For example, the adjustable divan bed base may comprise less or more than three pivotally adjustable mattress support panels. In addition other forms of actuator
 15 may be employed to move the respective mattress support panels. Further the intermediate support panel 32 may be removed in other arrangements or further intermediate panels may be provided in the areas of the other moveable panels.

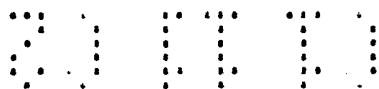

CLAIMS

1. A divan bed base for an articulated bed; the said base comprising a divan frame and a mattress support having at least one mattress support panel pivotally
5 mounted with respect to the said frame, and actuator means for pivoting the said panel whereby to adjust the geometry of the bed.
2. A divan base as claimed in Claim 1 wherein the or each mattress support panel is pivotally connected to the said frame about a (respective) pivot axis offset from the
10 plane of the panel.
3. A divan base as claimed in Claim 2 wherein the said pivot axis is offset above the panel on a mattress side of the base.
- 15 4. A divan base as claimed in Claims 1 to 3 wherein the said actuator means is located in a region below the mattress support on a side thereof opposite the mattress side.
5. A divan base as claimed in Claims 1 to 4 wherein the said actuator means is
20 fixed with respect to the said frame and connected to the said support panel for movement of the panel with respect to the frame.
6. A divan base as claimed in any preceding claim wherein the side edges of the said mattress support panel are substantially flush with side panels of the said frame.

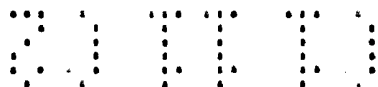

7. A divan base as claimed in any preceding claim wherein the mattress support comprises a first support panel fixed with respect to the frame, a second support panel pivotally mounted with respect to the frame on one side of the said first panel and
5 second support panel pivotally mounted with respect to the frame on the opposite side of the said first panel, whereby the said first, second and third panels provide an adjustable mattress support surface.

8. A divan base as claimed in Claim 7 wherein the said actuator means comprises
10 a pair of actuators for independently moving the said pivotally mounted support panels about their respective pivot axes.

9. A divan base as claimed in Claim 8 wherein the said actuators are linear actuators with each actuator having a movable ram connected to an underside of its
15 respective panel.

10. A divan base as claimed in Claim 9 wherein the actuators are mounted on a support member extending transversely between the sides of the divan base at an intermediate point between the two end panels of the base.

20

11. A divan base as claimed in any of Claims 7 to 10 further comprising a fourth support panel pivotally mounted in back to back relation with the side edge of the third support panel furthest from the first panel.

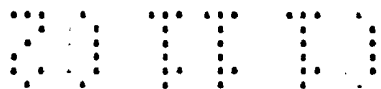

12. A bed including a divan base as claimed in any preceding claims.
13. A kit of parts for a divan base according to any preceding claim.
- 5 14. A divan base substantially as hereinbefore described and/or with reference to the accompanying drawings.



INVESTOR IN PEOPLE

Application No: GB 0224413.5
Claims searched: 1-12

Examiner: Alastair Kelly
Date of search: 15 April 2003

Patents Act 1977 : Search Report under Section 17

Documents considered to be relevant:

Category	Relevant to claims	Identity of document and passage or figure of particular relevance
X, Y	X:1, 4-12 Y:2, 3	US4589151 (BEHRENS) see figure 1
X	1, 4, 5, 7-10, 12	EP0368540 (OGDEN) see figures 1, 4 and 11
Y	2, 3	US5790993 (ROMA) see figure 2 pivot point 30
Y	2,2	GB2066656 (GRUNAU) see figure 1 pivot point 6

Categories:

X	Document indicating lack of novelty or inventive step	A	Document indicating technological background and/or state of the art.
Y	Document indicating lack of inventive step if combined with one or more other documents of same category.	P	Document published on or after the declared priority date but before the filing date of this invention.
&	Member of the same patent family	E	Patent document published on or after, but with priority date earlier than, the filing date of this application.

Field of Search:

Search of GB, EP, WO & US patent documents classified in the following areas of the UKC^v:

A4L

Worldwide search of patent documents classified in the following areas of the IPC⁷:

A47C, A61G

The following online and other databases have been used in the preparation of this search report:

On-line: EPODOC, WPI, JAPIO