



US00D631833S

(12) **United States Design Patent**  
**Onnerud et al.**

(10) **Patent No.:** **US D631,833 S**

(45) **Date of Patent:** **\*\* \*Feb. 1, 2011**

(54) **BATTERY PACK**

(75) Inventors: **Per Onnerud**, Framingham, MA (US);  
**Christina M. Lampe-Onnerud**,  
Framingham, MA (US)

(73) Assignee: **Boston-Power, Inc.**, Westborough, MA  
(US)

(\* ) Notice: This patent is subject to a terminal disclaimer.

(\*\* ) Term: **14 Years**

(21) Appl. No.: **29/312,313**

(22) Filed: **Oct. 14, 2008**

(51) **LOC (9) Cl.** ..... **13-02**

(52) **U.S. Cl.** ..... **D13/103**

(58) **Field of Classification Search** ..... D13/102-106,  
D13/110, 118-119, 184; 429/96-100, 163,  
429/176

See application file for complete search history.

(56) **References Cited**

U.S. PATENT DOCUMENTS

1,075,556	A *	10/1913	Fenoughty	.....	429/99
4,151,583	A *	4/1979	Miller	.....	362/205
4,288,733	A *	9/1981	Bilanceri et al.	.....	320/113
4,532,194	A *	7/1985	Liautaud et al.	.....	429/99
4,559,588	A	12/1985	Engelson et al.	.....	
D283,812	S *	5/1986	Liautaud et al.	.....	D13/103
D303,373	S *	9/1989	Ching, Jr.	.....	D13/103
D306,851	S *	3/1990	Weimann	.....	D13/103
D307,133	S *	4/1990	Ching, Jr.	.....	D13/103
D307,260	S *	4/1990	Happy et al.	.....	D13/102
5,001,772	A *	3/1991	Holcomb et al.	.....	455/575.1
D334,169	S	3/1993	Antonczak	.....	
5,246,790	A *	9/1993	Mooney et al.	.....	429/7
5,357,411	A	10/1994	Menke et al.	.....	
D372,701	S *	8/1996	Tahmassebpur	.....	D13/103
D388,060	S *	12/1997	Tanaka et al.	.....	D13/103
D390,187	S *	2/1998	Urvoy	.....	D13/103
5,736,271	A *	4/1998	Cisar et al.	.....	429/96

5,736,272	A *	4/1998	Veenstra et al.	.....	429/99
5,804,332	A	9/1998	Shimizu et al.	.....	
D406,258	S *	3/1999	Segers	.....	D13/103
D409,975	S *	5/1999	Zeller	.....	D13/103
5,907,227	A	5/1999	Domei et al.	.....	

(Continued)

OTHER PUBLICATIONS

TechRepublic Photo Gallery blog, Author Unknown, titled "Boston-Power's 'Sonata' battery". Dated Jan. 30, 2007 (Part 1 of 2) (2 pages). ([http://techrepublic.com.com/2346-10877\\_11-42504-1.html](http://techrepublic.com.com/2346-10877_11-42504-1.html)).\*

(Continued)

*Primary Examiner*—Rosemary K Tarcza  
(74) *Attorney, Agent, or Firm*—Hamilton, Brook, Smith & Reynolds, P.C.

(57) **CLAIM**

The ornamental design for a battery pack, as shown and described.

**DESCRIPTION**

FIG. 1 is a perspective view of a battery pack showing our new design.

FIG. 2 is a top plan view of FIG. 1, with the bottom plan view being identical.

FIG. 3 is a side elevational view of FIG. 1, with the other side view being identical; and,

FIG. 4 is a front elevational view of FIG. 1, with the rear view being identical.

The article is a battery pack. The battery pack is a combination of individual batteries arranged as shown. The claim is directed to the collective appearance of the individual batteries in the combination shown.

**1 Claim, 1 Drawing Sheet**

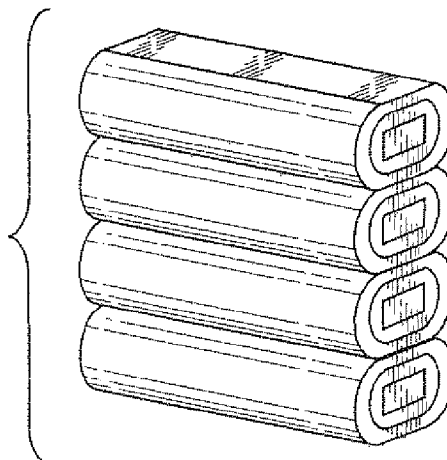

## U.S. PATENT DOCUMENTS

5,928,809	A *	7/1999	Ju	429/100	7,510,797	B2 *	3/2009	Aker et al.	429/120
5,958,618	A *	9/1999	Sullivan	429/99	D597,936	S *	8/2009	Walsh et al.	D13/103
5,962,159	A *	10/1999	Satou et al.	429/99	7,614,107	B2	11/2009	Cobabe et al.	
D424,513	S *	5/2000	Birkestrand	D13/103	2002/0022159	A1 *	2/2002	Pierson et al.	429/1
D424,933	S *	5/2000	Albright et al.	D9/423	2003/0003350	A1 *	1/2003	Heimer et al.	429/99
D425,417	S *	5/2000	Gaffney et al.	D9/423	2003/0006733	A1	1/2003	Abe	
6,120,932	A *	9/2000	Slipy et al.	429/99	2003/0044677	A1 *	3/2003	Naruoka	429/161
6,218,042	B1 *	4/2001	Naudet et al.	429/97	2003/0129487	A1 *	7/2003	Inoue et al.	429/176
6,224,997	B1 *	5/2001	Papadopoulos	429/99	2004/0155951	A1	8/2004	Tanaka	
D445,758	S *	7/2001	Killebrew et al.	D13/103	2004/0191614	A1 *	9/2004	Iwasaki et al.	429/96
6,283,611	B1	9/2001	Sharrah et al.		2004/0219422	A1 *	11/2004	Hauck et al.	429/96
6,303,248	B1 *	10/2001	Peterson	429/177	2004/0241539	A1 *	12/2004	Katayama	429/97
6,334,697	B1	1/2002	Gappelberg et al.		2005/0058891	A1 *	3/2005	Marraffa	429/99
D454,110	S *	3/2002	Andre et al.	D13/110	2005/0122715	A1	6/2005	Furth et al.	
D457,133	S *	5/2002	Yoneyama	D13/103	2005/0144744	A1	7/2005	Thiess et al.	
D461,163	S *	8/2002	Hirano et al.	D13/103	2005/0150067	A1	7/2005	Cobabe et al.	
6,433,498	B1	8/2002	Domei et al.		2005/0191544	A1 *	9/2005	Casanova	429/100
6,447,949	B2 *	9/2002	Iwata et al.	429/185	2006/0007721	A1 *	1/2006	Rodriguez et al.	363/146
6,558,835	B1 *	5/2003	Kurisu et al.	429/159	2006/0024566	A1 *	2/2006	Plummer	429/100
6,636,732	B1 *	10/2003	Boling et al.	455/404.1	2006/0034073	A1	2/2006	Uke	
D481,557	S	11/2003	Harris		2006/0076923	A1 *	4/2006	Eaves	320/112
D488,027	S	4/2004	Lin		2006/0091849	A1 *	5/2006	Huynh et al.	320/112
D491,888	S *	6/2004	Lee	D13/103	2006/0119317	A1 *	6/2006	Kogan et al.	320/112
D504,349	S	4/2005	Shagalov		2006/0176689	A1 *	8/2006	Dowdy et al.	362/188
6,930,697	B2	8/2005	Tanaka		2006/0291198	A1 *	12/2006	Dalton et al.	362/191
6,942,359	B2	9/2005	Furth et al.		2007/0002559	A1 *	1/2007	Uke	362/157
D510,721	S	10/2005	Axelrod		2007/0019402	A1 *	1/2007	Dalton et al.	362/157
7,033,695	B2	4/2006	Sawachi		2007/0034258	A1	2/2007	Parsons et al.	
D524,728	S	7/2006	Watson		2007/0126397	A1 *	6/2007	Kogan et al.	320/112
D528,974	S	9/2006	Tang		2007/0133197	A1 *	6/2007	Shiau	362/157
7,105,247	B2 *	9/2006	Suzuki	429/96	2007/0210745	A1 *	9/2007	Dingeldein	320/112
D529,437	S	10/2006	Miyashita		2007/0231680	A1	10/2007	Satoh et al.	
D529,709	S	10/2006	Swartz et al.		2007/0264536	A1 *	11/2007	Mizoguchi	429/9
D532,363	S	11/2006	Morisawa		2008/0096521	A1 *	4/2008	Boling et al.	455/404.2
D535,195	S	1/2007	Schwab		2008/0124618	A1 *	5/2008	Shimoyama	429/99
D537,034	S *	2/2007	Kang et al.	D13/103	2008/0182162	A1 *	7/2008	Kim	429/99
7,176,655	B2 *	2/2007	Kogan et al.	320/112	2008/0211309	A1 *	9/2008	Nolte	307/66
D538,222	S *	3/2007	Curello et al.	D13/103	2008/0305387	A1 *	12/2008	Murray et al.	429/100
D543,867	S	6/2007	Yourist		2009/0111015	A1 *	4/2009	Wood et al.	429/164
D545,759	S	7/2007	Ino et al.		2009/0148754	A1 *	6/2009	Marchio et al.	429/83
D547,264	S *	7/2007	Kondo	D13/103	2009/0207595	A1 *	8/2009	Sharrah et al.	362/158
D548,684	S *	8/2007	Eto et al.	D13/103	2010/0017978	A1	1/2010	Cobabe et al.	
7,270,576	B2 *	9/2007	Kim et al.	439/627					
7,278,753	B2	10/2007	Uke						
7,304,453	B2 *	12/2007	Eaves	320/120					
7,360,269	B2	4/2008	Cobabe et al.						
7,390,590	B2	6/2008	Wani et al.						
D576,100	S *	9/2008	Wang	D13/110					
D586,739	S *	2/2009	Zaremba et al.	D13/103					
D586,740	S *	2/2009	Song	D13/103					
D586,741	S *	2/2009	Song	D13/103					
7,510,537	B2	3/2009	Imboden et al.						

## OTHER PUBLICATIONS

TechRepublic Photo Gallery blog, Author Unknown, titled "Boston-Power's 'Sonata' battery". Dated Jan. 30, 2007 (Part 2 of 2) (2 pages). ([http://techrepublic.com.com/2346-10877\\_11-42504-2.html](http://techrepublic.com.com/2346-10877_11-42504-2.html)).\*

Engadget.com article by Donald Melanson, Boston-Power unveils long-lasting "Sonata" laptop battery. Dated Jan. 30, 2007. (5 pages) (<http://www.engadget.com/2007/01/30/boston-power-unveils-long-lasting-sonata-laptop-battery/>).\*

\* cited by examiner

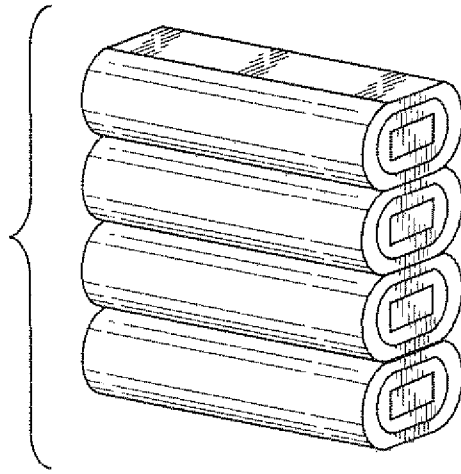

FIG. 1

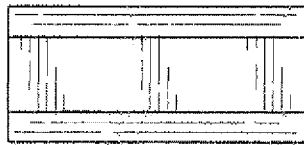

FIG. 2

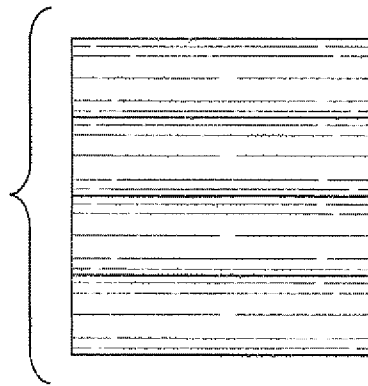

FIG. 3

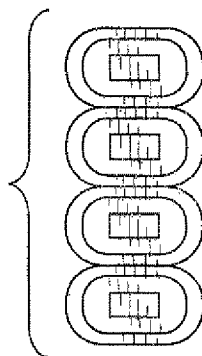

FIG. 4