

(19)
(12)

(KR)
(A)

(51) 。 Int. Cl. ⁷
H01H 61/00

(11)
(43)

2001 - 0055321
2001 07 04

(21) 10 - 1999 - 0056508
(22) 1999 12 10

(71)

20

(72)

가

101 - 1207

(74)

:

(54)

가

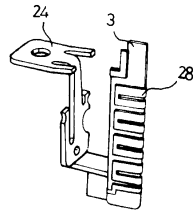
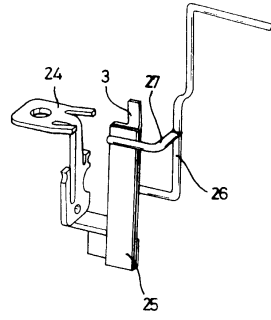

1

2

3

4

5 4

3 : 25,28 :

(Assembly)

(Trip)

1

(1) 가 (2) (3) (3) (3a)
(4)가

(1) (5)가 (5)

(6) (6) (5) (5a) 가 (7) (7)
(6a) 가

(8) (8) (4) (4a) (4)

(4a)가 (8) (8)

(6) (6) (6) (6) (9)
(10)가 (6) (5) (11)

(7) (12) (12) (14)
(15) (15a)

(12) (13) (7) (12)

가 (17) (16) (19) (18) ,
가 (17) (15) (15b)가 (12)

(15)

(22) (21) (Reset) (23) (15)
(23) (22)

(3) 가 (2) 가 가 (2) (3) (3a)
(4)가 (4)가 (4) (4a)가
(8) (8)

(8) (7)가 (6) (6a)
(7) (7) 가 (12)
(12)가 (15) (15a) (12)

가

(15) (5)
(15b) 가 (17) 가 (17)
(19) , 가 (22)

2 (3) (3) (24)가
(3) 가 (2)가

(3) 가 (2)
, 가 (2)

(Short) 가 (2) 가 (2) 가 (2) 가 (2) 가 (2) 가 (2) 가 (2)

가 가

가 .

3 (3) (27) (26) (25) (25) (25) (25) (24)가 (25) (24) (3)

4 (28) (3) (27) (26) (28) (3) (24)가 (24)

3) 가 , $\langle \text{MARGN} \rangle \langle \text{TR} \rangle \langle P \rangle D = \frac{k \pi^2}{l} \langle P \rangle$ (

D , 가 가 , L , t

1.

(3)

(24)

2.

1

,

(25)

3.

1

,

(28)

1

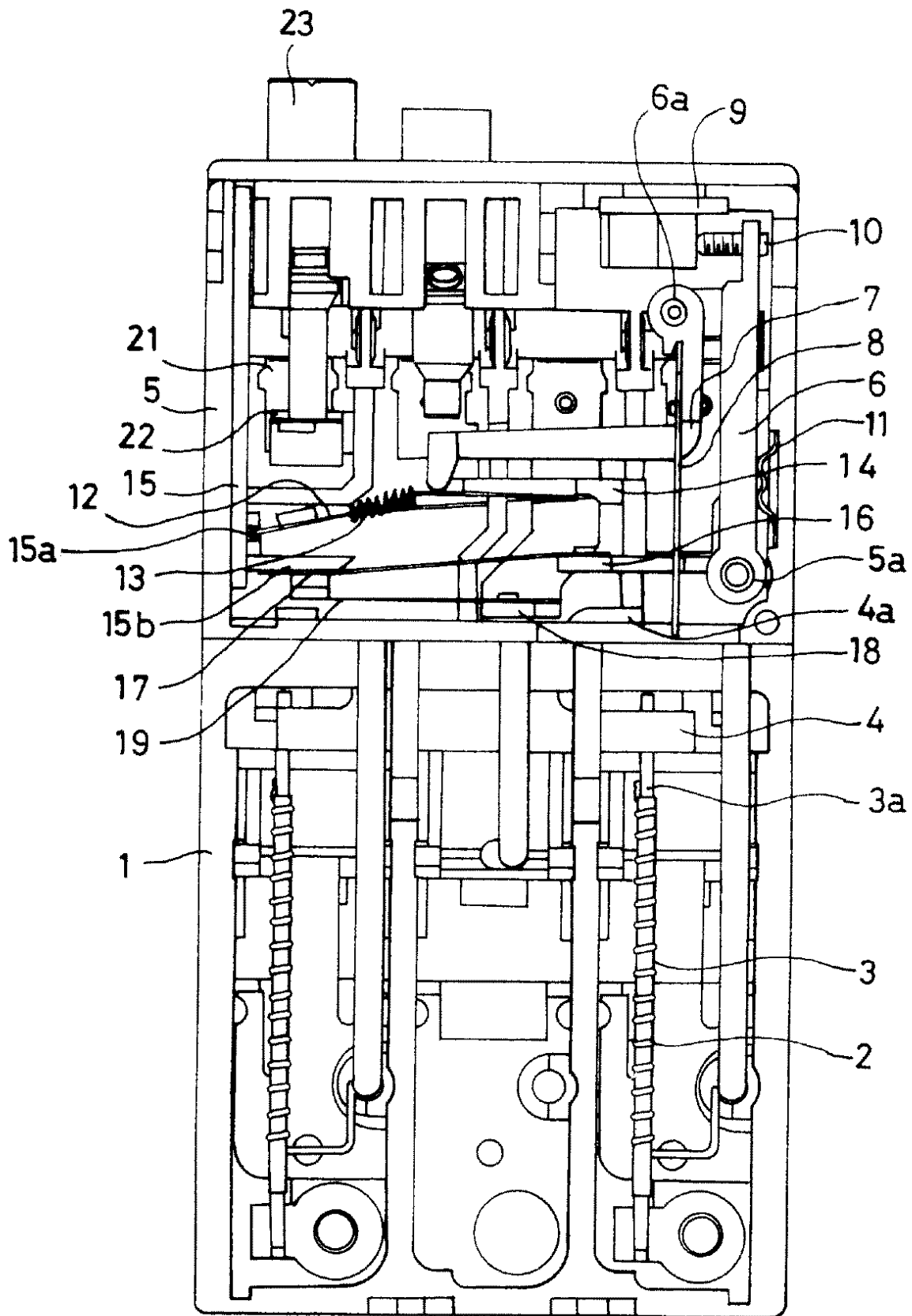

2

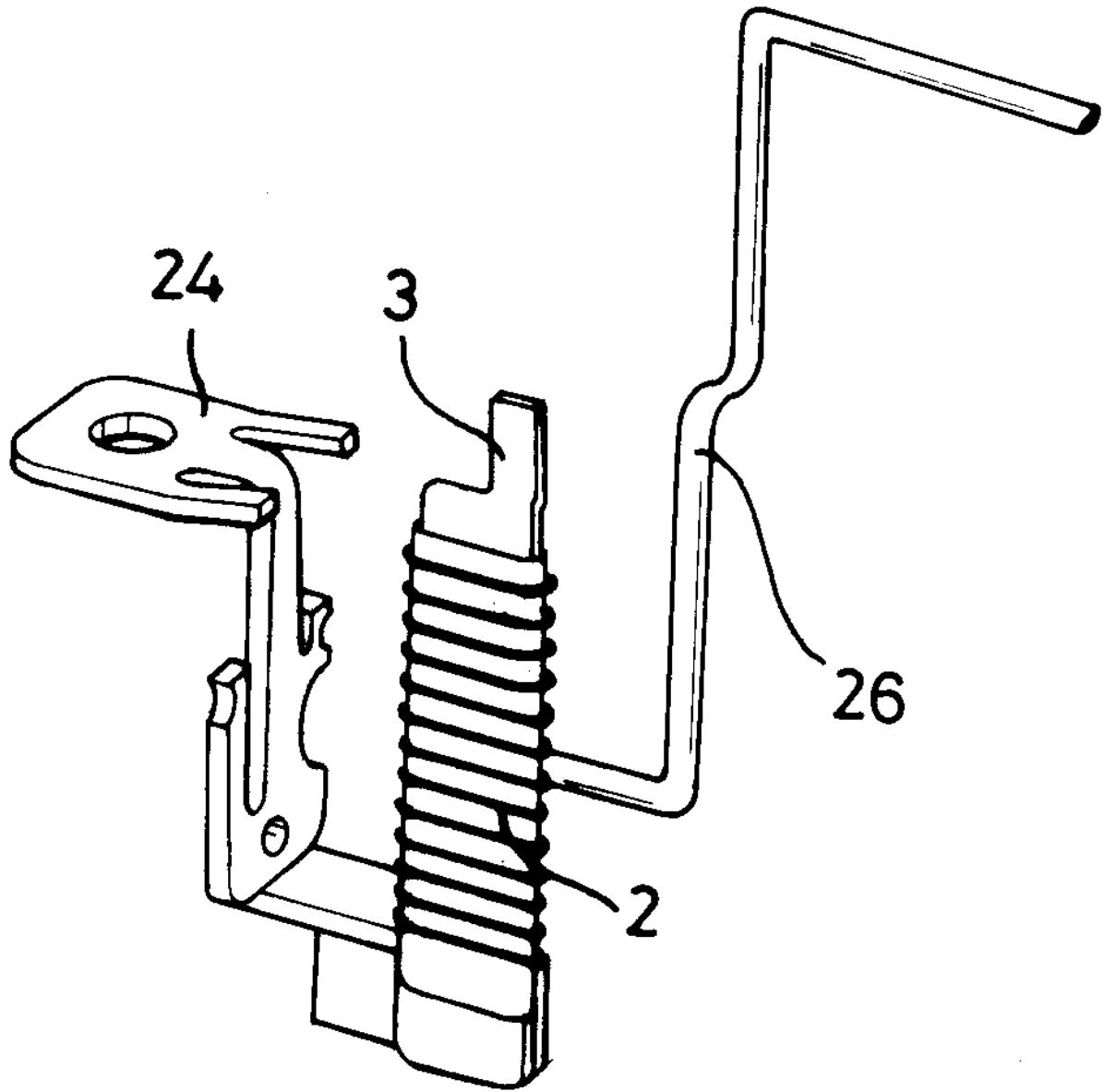

3

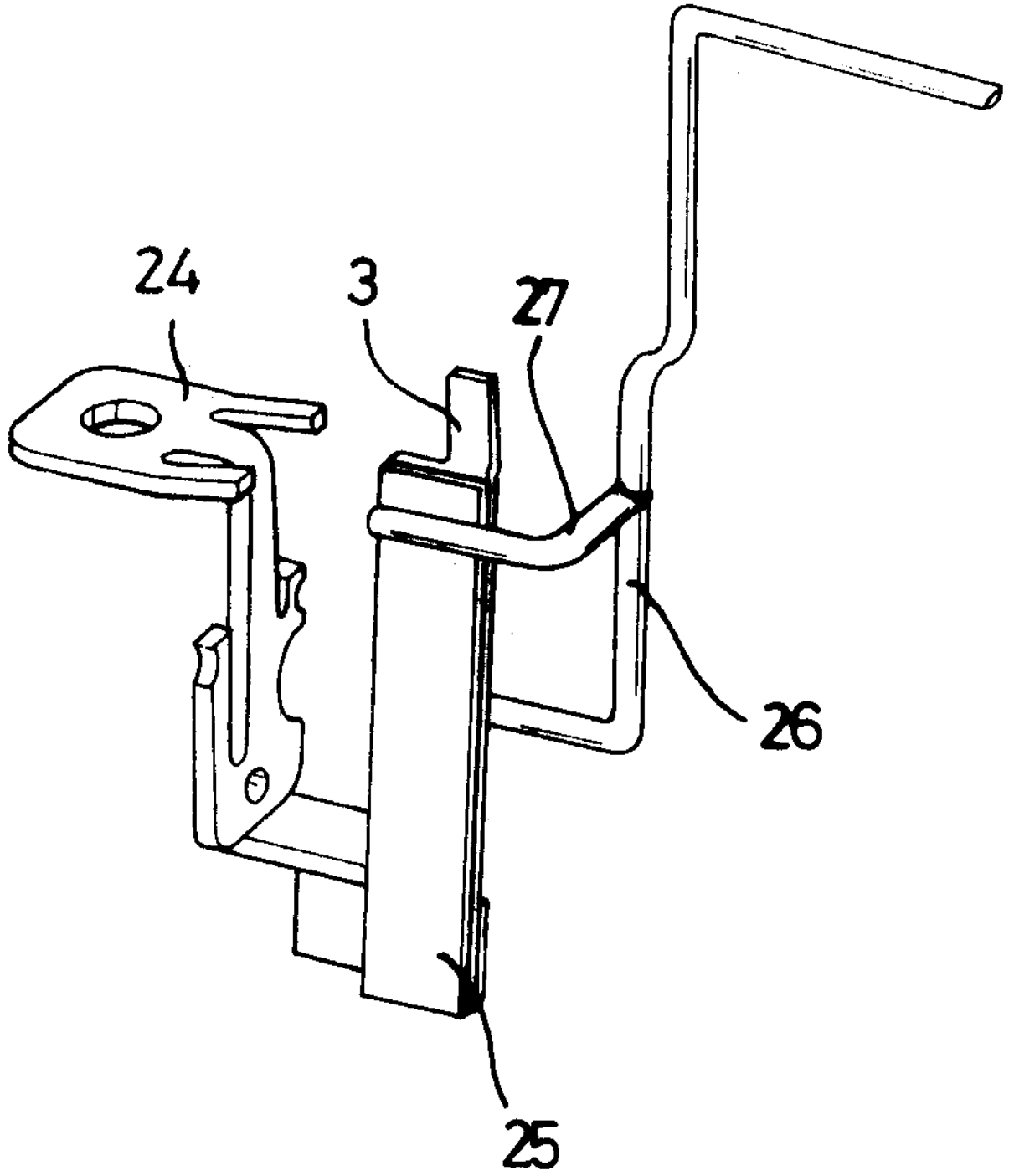

4

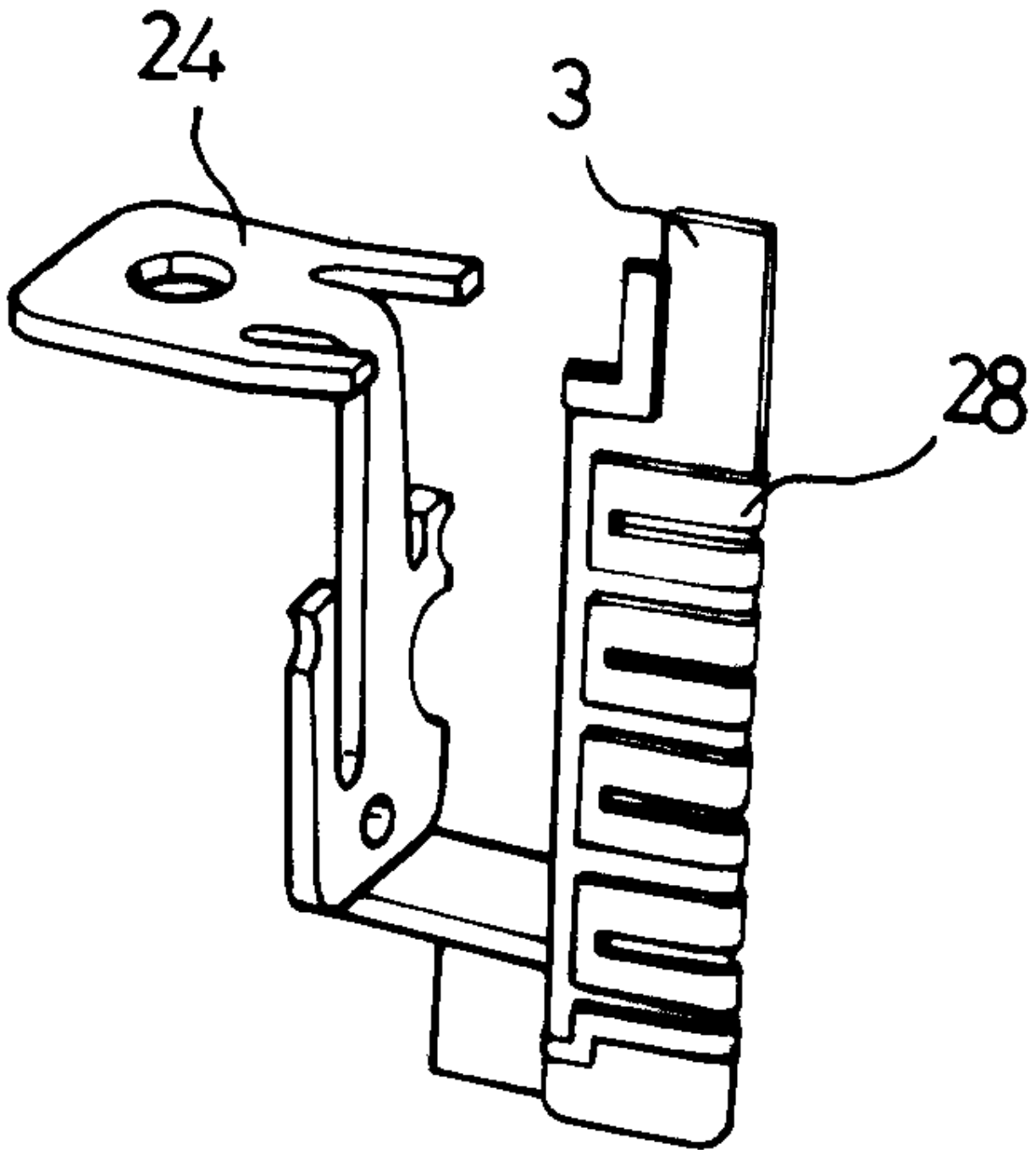

5

