

(21) Application No: 1704509.7

(22) Date of Filing: 22.03.2017

(71) Applicant(s):  
Be Hive Technologies Limited  
Affinity Point, 8 Arundel Road, Uxbridge, Middlesex,  
UB8 2RR, United Kingdom

(72) Inventor(s):  
Garry Woods

(74) Agent and/or Address for Service:  
Downing IP Ltd  
Grosvenor House, 7 Horseshoe Crescent,  
BEACONSFIELD, Buckinghamshire, HP9 1LJ,  
United Kingdom

(51) INT CL:  
F24F 12/00 (2006.01)

(56) Documents Cited:  
EP 1923643 A2 EP 0536445 A1

(58) Field of Search:  
INT CL F24F  
Other: EPODOC, WPI, Patent Fulltext

(54) Title of the Invention: **Mechanical ventilation heat recovery apparatus**  
Abstract Title: **Mechanical ventilation heat recovery system for a building with switchable air flows**

(57) A Mechanical Ventilation Heat Recovery (MVHR) system is suitable for a building 2 having a roof with at least two pitched slopes 4, 6 facing in different directions. A Heat Recovery Unit HRU is connected by fluid flow conduits 8, 12 to first and second ports 10, 14 located on different pitched slopes 4, 6 and exchanges heat between a flow of ambient air from outside the building and a flow of building air from within the building. A flow diverter 20 in the conduits 8, 12 between the HRU and the ports 10, 14 switches between a first state in which ambient air flows in through the first port 10 and the HRU and building air flows out through the HRU and the second port 14, and a second state in which ambient air flows in through the second port 14 and the HRU and building air flows out through the HRU and the first port 10. The MVHR system may also comprise an air source heat pump (26, Fig. 4a) and a solar panel (22, Fig. 4a).

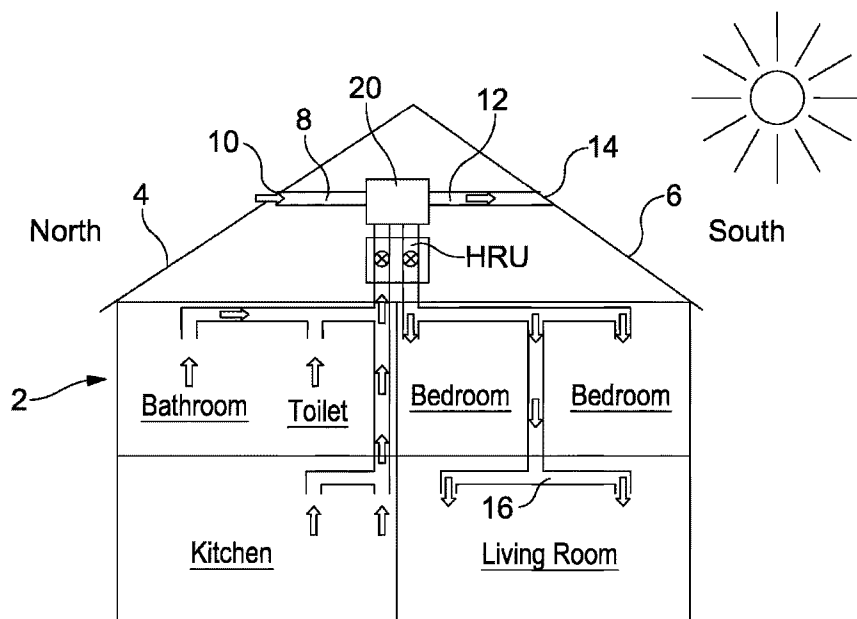

Fig. 2a

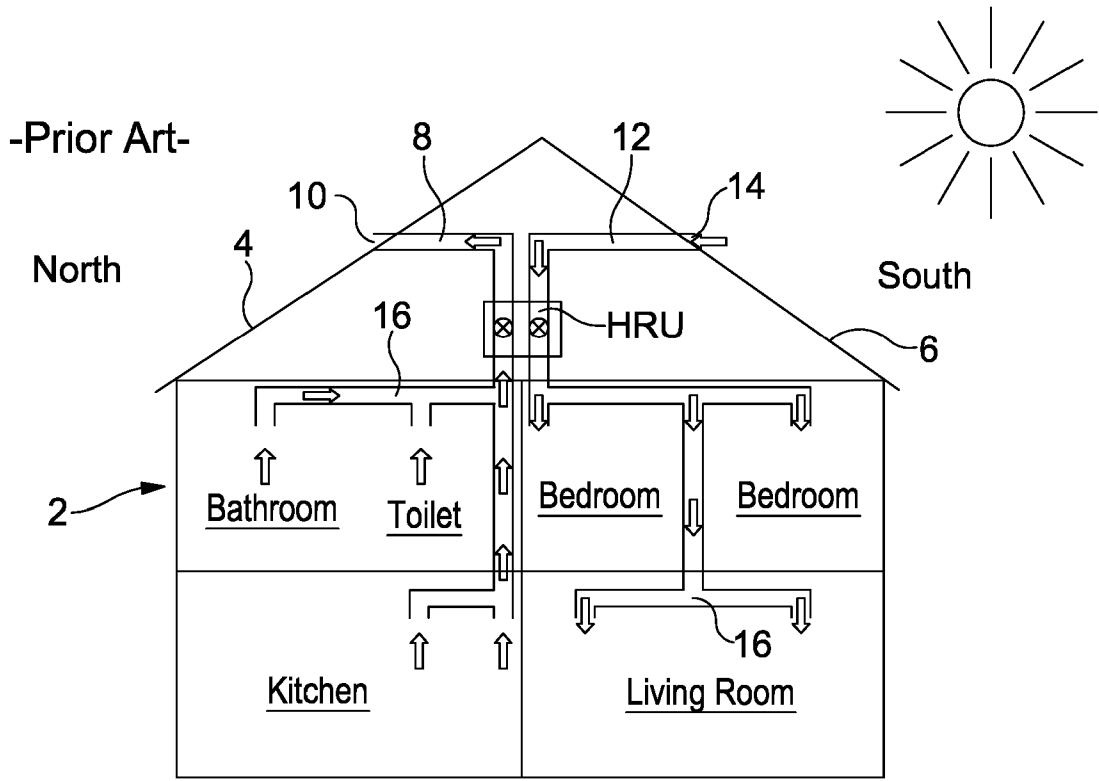

Fig. 1

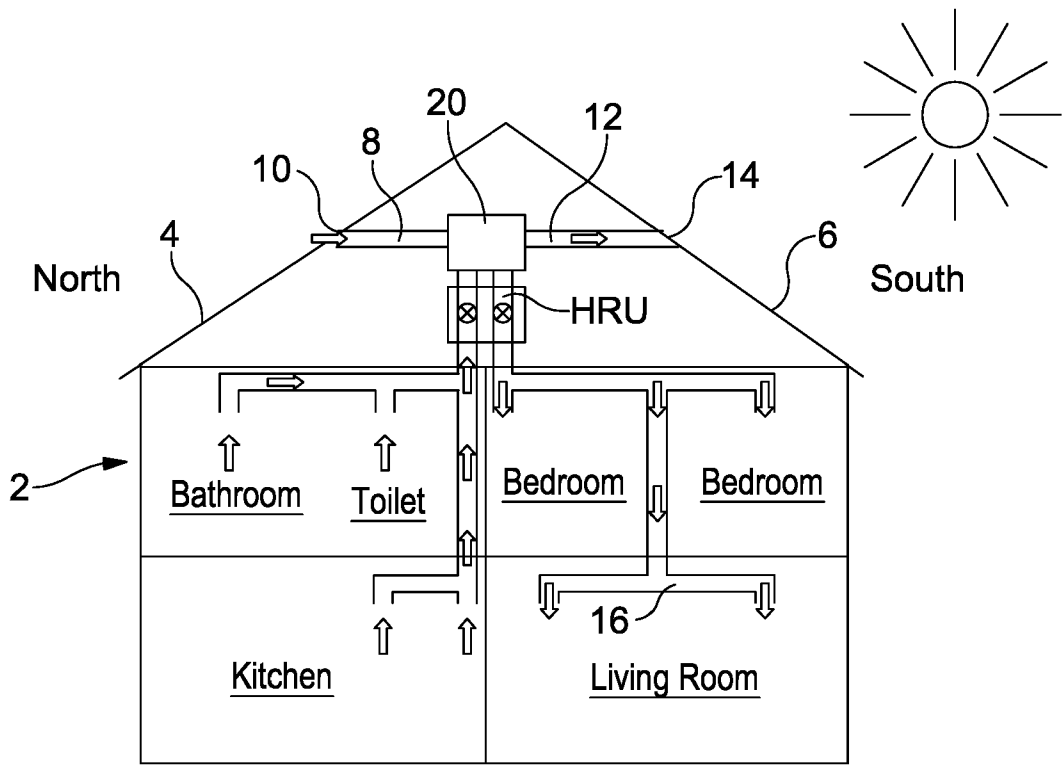

Fig. 2a

19 06 18

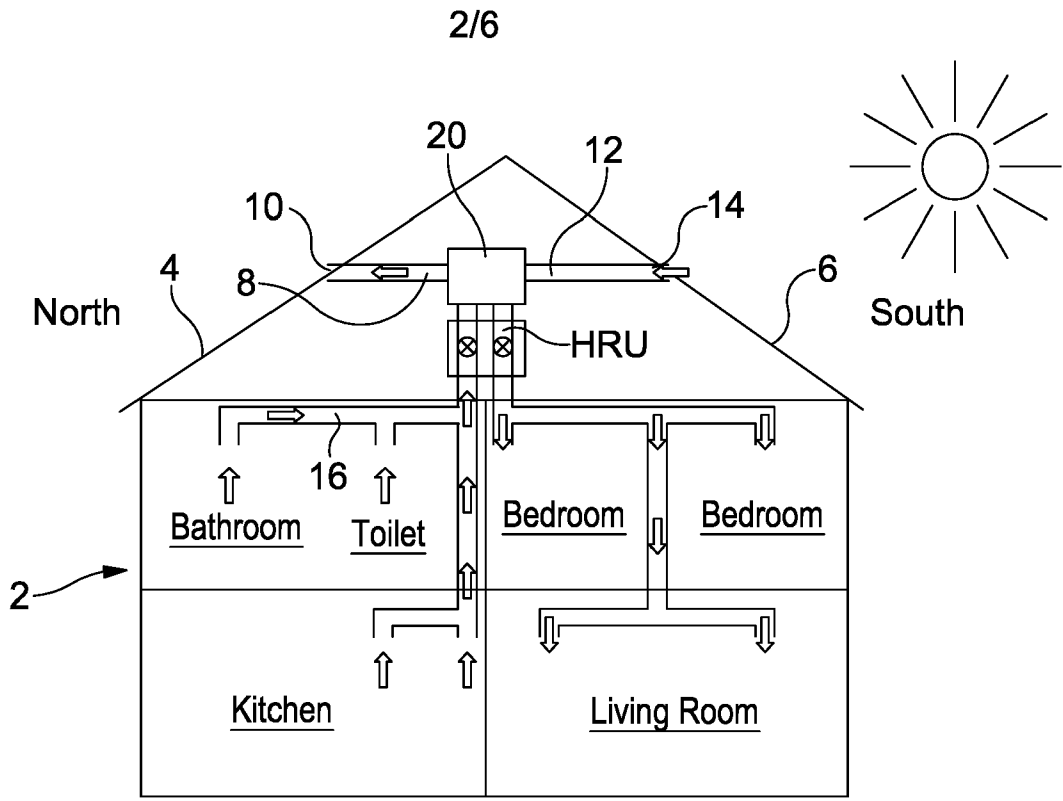

Fig. 2b

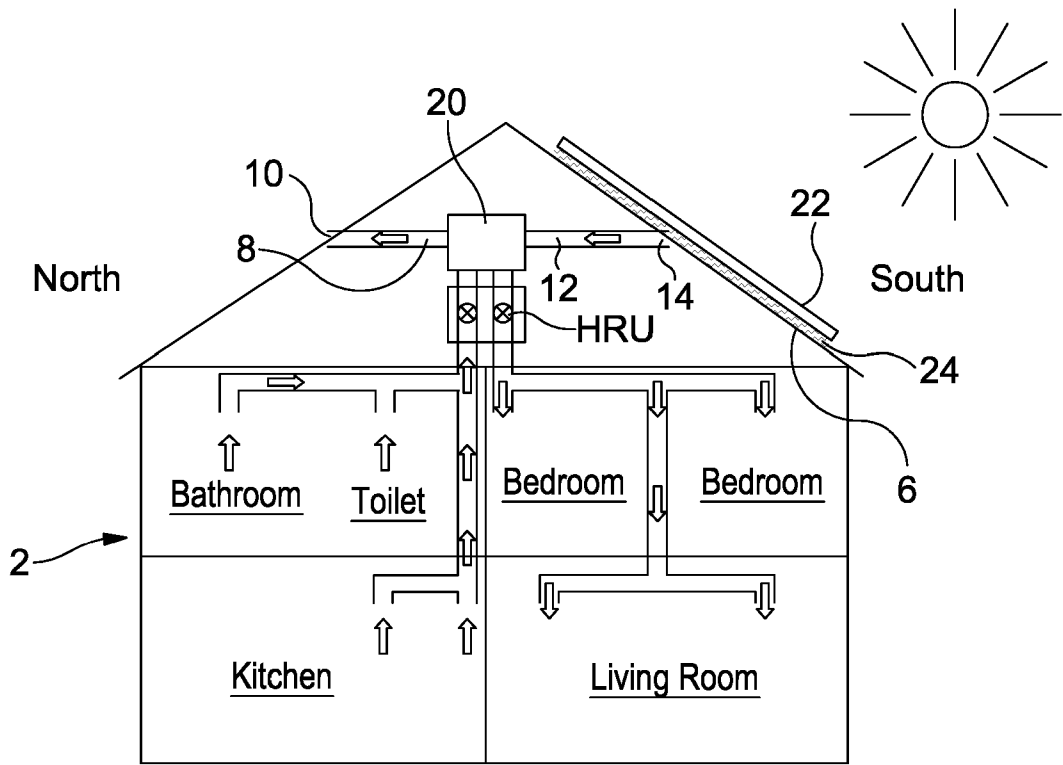

Fig. 3

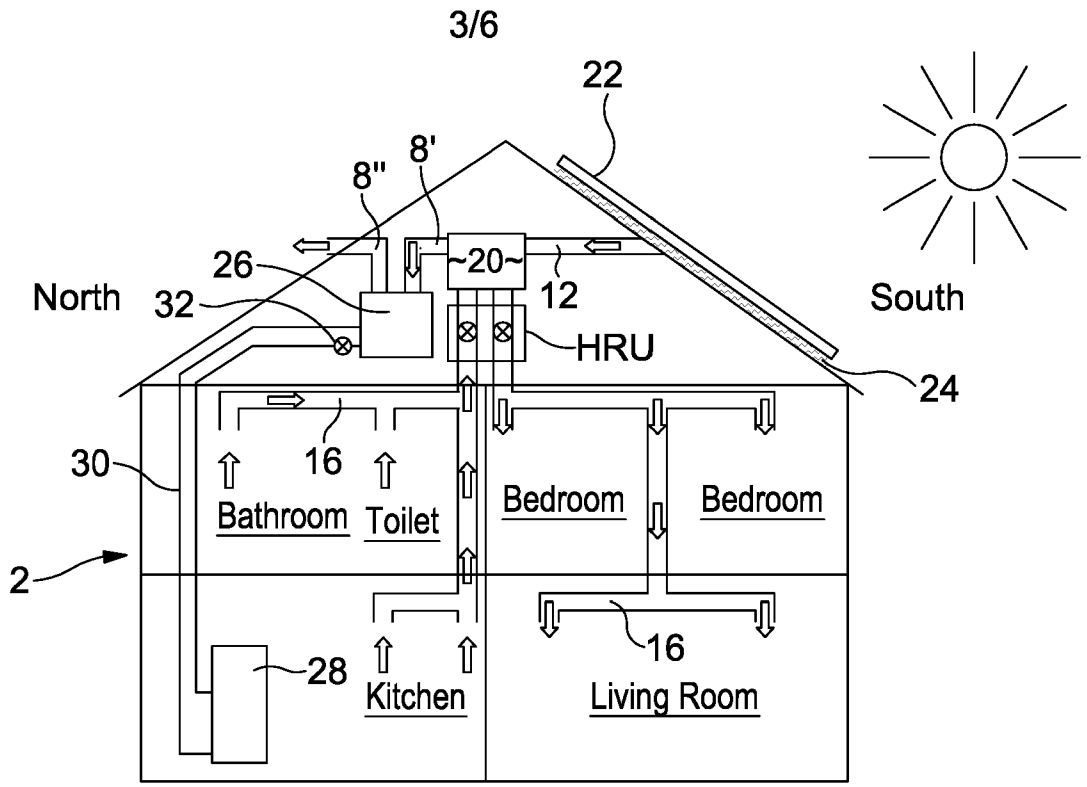

Fig. 4a

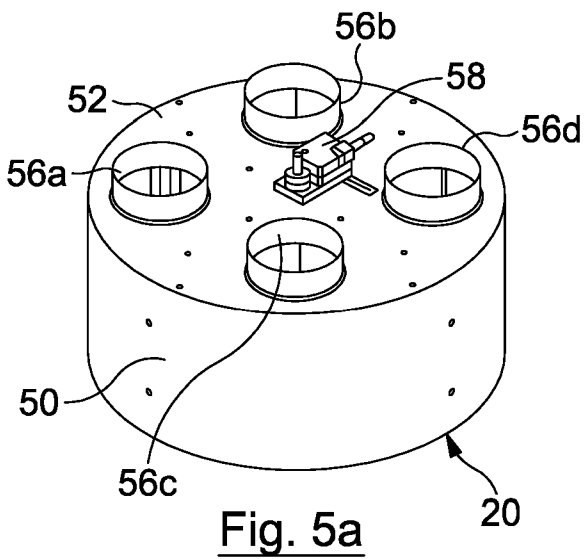

Fig. 5a

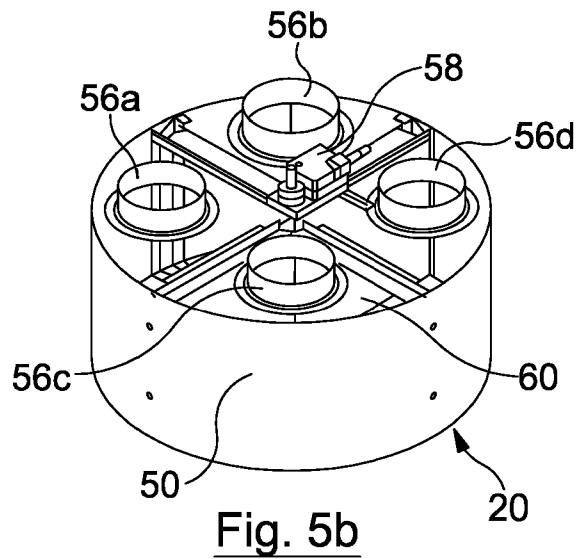

Fig. 5b

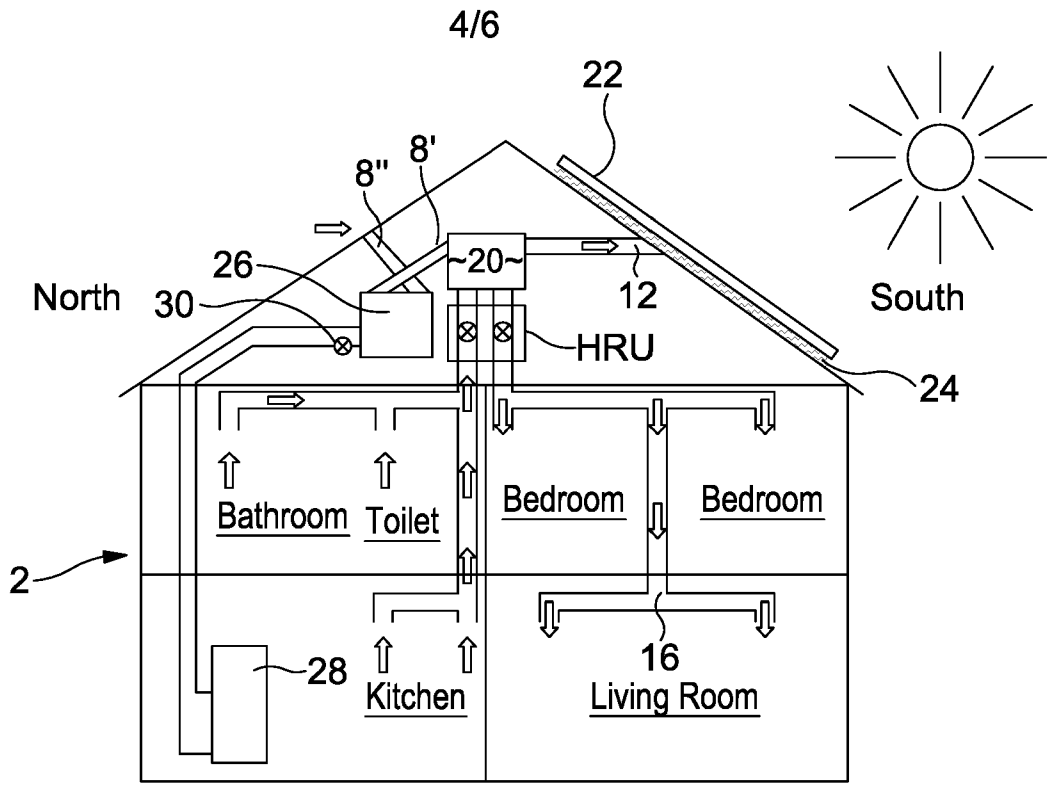

Fig. 4b

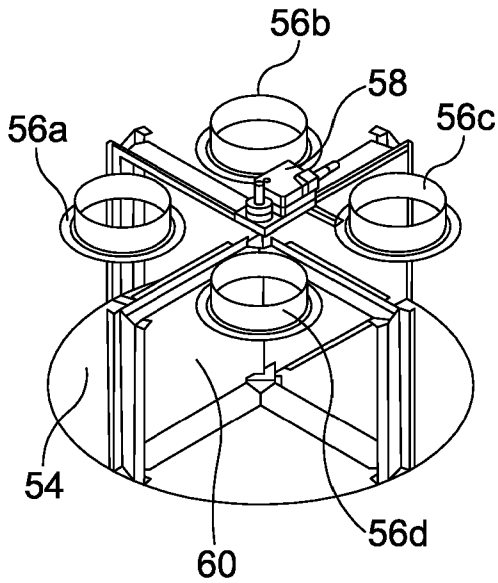

Fig. 5c

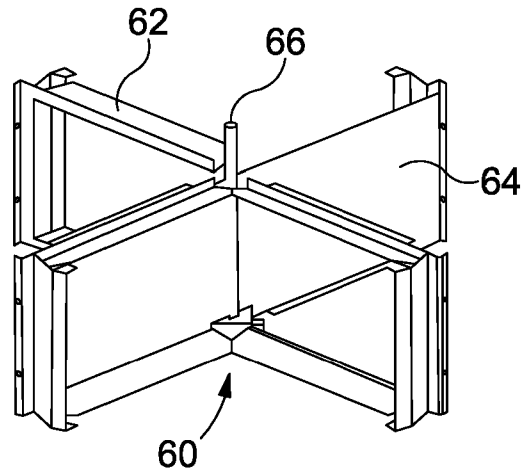

Fig. 5d

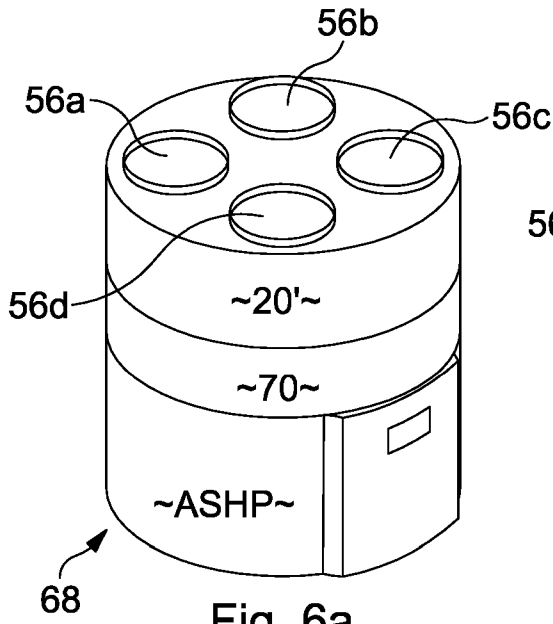

Fig. 6a

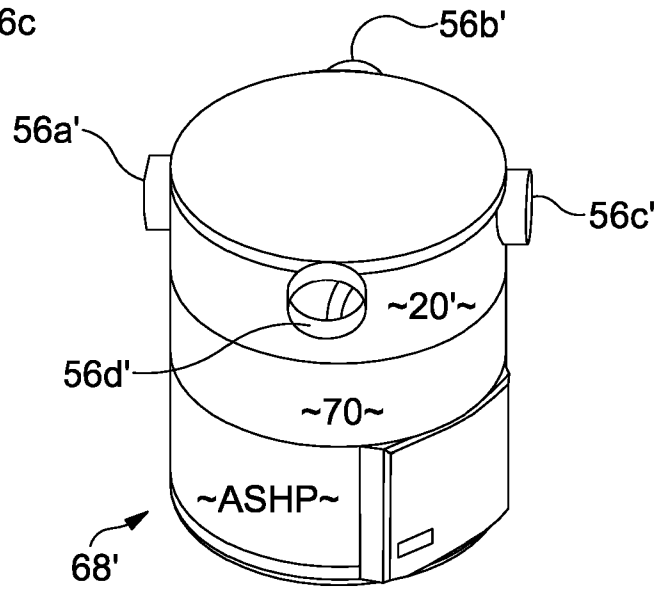

Fig. 6b

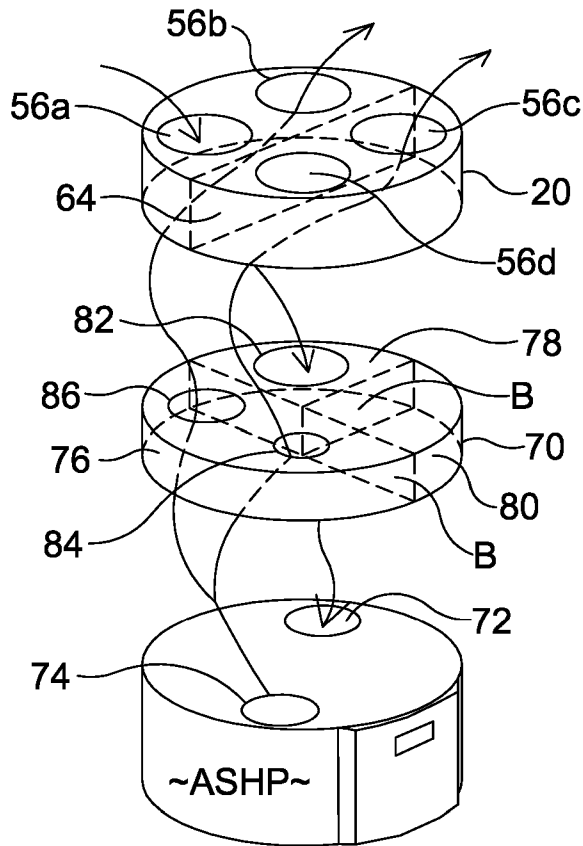

Fig. 7c

19 06 18

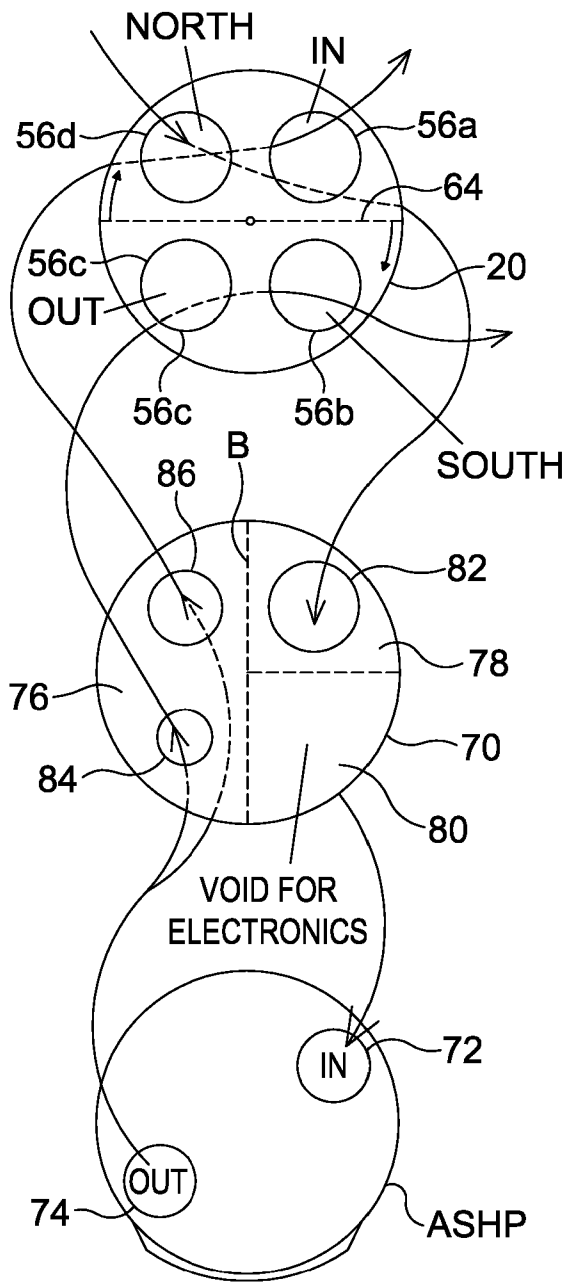

Fig. 7a

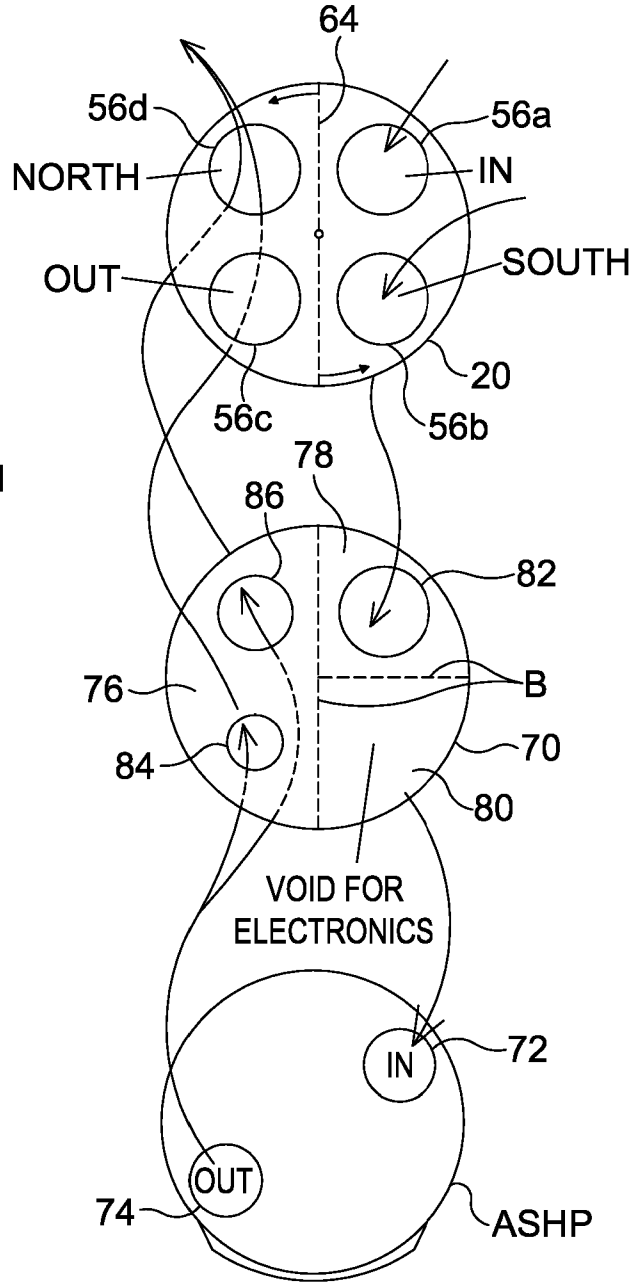

Fig. 7b

## Mechanical Ventilation Heat Recovery Apparatus

5

### FIELD OF THE INVENTION

The present invention relates to Mechanical Ventilation Heat Recovery (MVHR) system for buildings, particularly but not exclusively domestic buildings.

### BACKGROUND ART

In the search for improvements in the efficiency of buildings such as by increased thermal insulation and weatherstripping (the process of sealing openings such as doors, windows, and trunks from the elements), modern buildings have become more airtight and less well ventilated and thus require some form of energy-effective ventilation system. MVHR systems are energy recovery ventilation systems which use an air-to-air heat exchanger, or Heat Recovery Unit (HRU) which causes the inbound air flowing into the building to exchange heat with the outbound air flowing out of the building, thus providing fresh air inside the building whilst also saving energy by reducing the heating (or cooling) requirement for the inbound air necessary for the interior of the building to be maintained at a comfortable temperature. There are many different types of air-to-air heat exchanger available, some of which are also capable of transferring the humidity level of the exhaust (outbound) air to the intake (inbound) air. MVHR systems are becoming increasingly prevalent in new buildings and new build houses. Many MVHR systems take advantage of buildings which are designed with a pitched roof, i.e. a roof having at least two pitched slopes; often there is unused space under at least a part of the pitched roof, so that many of the elements of the MVHR system (the HRU, the fans, etc.) can conveniently be placed in this space, and the ducting leading to the inlet for inbound air and to the outlet for exhaust



air can also fit into this space. Consequently the inlet and outlet are often located on the pitched slopes, usually on different, often opposite slopes.

One problem with conventional MVHR systems is that they function by exploiting the difference between ambient temperature outside the building and the desired temperature inside the building. Whilst the desired internal temperature varies little according to season (the normal range of inside air temperatures which are deemed comfortable for humans is between about 16° C and about 22° C), ambient temperature outside the building varies over a much greater range (in the United Kingdom between about -5° C and about 30° C). In recognition of this variability in ambient temperature, and that whatever the ambient temperature one side of a building (the side which generally faces north) is usually cooler than another (the side which generally faces south), it is common for MVHR systems to be installed so that inbound air is drawn from one side of the building, whilst outbound air exhausts from another side of the building, usually the opposite side. This takes advantage of the fact that when one side of a building is in direct sunlight, the opposite side is in shade. A feature of MVHR systems is that they are essentially static, in that their essential elements are fixed in position (they form part of the building). This means that if the inbound air is drawn from the southerly side of the building, in winter this air is warmer than the air on the northerly side of the house, thus reducing the energy required to raise it to the required internal temperature; however, in summer this inbound air is much warmer than the desired internal temperature, and warmer than the air on the northerly side of the house, thus increasing the energy required to lower it to the required internal temperature. If the inbound air is drawn from the northerly side of the building, in summer this air is cooler than the air on the southerly side of the house, thus reducing the energy required to lower it to the required internal temperature; however, in winter this inbound air is much colder than the desired internal temperature, and colder than the air on the southerly side of the house, thus increasing the energy required to raise it to the required internal temperature. One solution to this might be to reverse the flows through the MVHR system according to season; however, MVHR systems are not designed for reverse flows. Within the building, air inlets and outlets are located so as to be most efficient at introducing fresh air and removing exhaust air and so as to minimise the noise of the fan(s) which drive the air flows, so reversing the air flows would adversely affect the efficiency of the system, and lead to increased noise. It is also common for the inbound air to pass through a filter system, to remove undesirable dust, pollen, etc. from the inbound air before it enters the

building; reversing the flow of air would risk allowing inbound air to entrain these filtered particles and carry them inside the building to the discomfort of the occupants. Further, if the air flows were to be reversed then it would be necessary to provide a second filter system to remove undesirable particles from the inbound air flow when the flow is reversed.

5

#### SUMMARY OF THE INVENTION

The present invention therefore provides an MVHR system for a building having a roof with at least two pitched slopes facing in different directions, the MVHR system comprising a Heat Recovery Unit (HRU) for receiving and exchanging heat between a flow of ambient air from outside the building and a flow of building air from within the building, the HRU being connected by fluid flow conduits to first and second ports located on different pitched slopes, in which a flow diverter is provided in the conduits between the HRU and the ports, the flow diverter being switchable between a first state in which ambient air flows from the first port to the HRU and into the building and building air flows from the HRU to the second port to be exhausted from the building, and a second state in which ambient air flows from the second port to the HRU and into the building and building air flows from the HRU to the first port to be exhausted from the building.

With such an arrangement the inbound and outbound air flows can be reversed upstream of the HRU, and upstream of all other elements of the MVHR system such as filters, fans, etc. so that in operation there is no flow reversal in the majority of the system, and the problems associated with flow reversal described above can be avoided. Moreover, because the system can be controlled so as to choose which port to draw inbound air from (namely that where the ambient air temperature requires the least energy to raise or lower it to the desired temperature inside the building) overall energy usage by the MVHR system is reduced. In summer, relatively cool air from the northerly side of the building's roof can be drawn in, and in winter relatively warm air from the southerly side of the building's roof can be drawn in as inbound air. The invention saves energy due to significant heating and hot water reduction in (mostly) the spring and autumn months when there is still plenty of sun light but the house needs heating in the evening. In winter when the sun comes out it is hoped to reduce the heating demand by the warm air entering and by reducing the amount of time the building's main heat source (which could be any other heat source, such

as a gas boiler or an Air Source Heat Pump (ASHP)) needs to run, so that the expected saving in winter should be in the region of 20 to 30%. When the system is used for cooling it will of course reduce the temperature in the house and will also reduce the energy demand if there were some sort of active cooling system in the property, but if there is no such cooling system it provides a method of reducing the internal temperature (and has no saving as such indirectly of energy).

In practice, few buildings are orientated precisely North-South, but with most pitched roofs it will be possible to identify one pitched slope which is more northerly facing and another which is more southerly facing, and the ports would normally be located on these faces so as to optimise the energy saving potential. It may be advantageous (and possible) to locate the ports on pitched slopes which face in opposite directions.

The flow diverter is preferably adapted to switch the flows of ambient and building air between the first and second states simultaneously. A simultaneous flow change upstream of the HRU and of the remainder of the MVHR system means that there is no pressure change in the system downstream of the flow diverter which might dislodge dust or other undesirable particles and introduce them into the air flowing into the building, and also minimises noise because the flow diverter can "balance" the instantaneous changes as it operates. The flow diverter may incorporate a separate plenum for each flow of air, into and out of the building, to flow through; these plenums acts advantageously as noise attenuators, and can also act as "traps" to supplement any filters for trapping unwanted particles in the inbound air.

The flow diverter may comprise a generally airtight and cylindrical drum having four ports for air to flow through located on at least one end face of the drum, the drum containing a rotatable vane, the ports being disposed such that rotation of the vane within the drum switches air flows between the first and second states, or vice versa. This simple arrangement, which is described further below, is simple and inexpensive to manufacture. Moreover, rotary movement of the vane can be in the horizontal plane (i.e. about an essentially vertical axis), which allows the vane to be balanced and minimises the power required to turn it.

The system may further comprise a sensor for determining the ambient temperature outside the building, and a controller adapted to switch the flow diverter from the first state

to the second when the ambient temperature exceeds a first threshold temperature. The controller can be adapted to switch the flow diverter from the second state to the first when the ambient temperature is less than a second threshold temperature. In this way, the system can be set up so as to optimise energy savings according to the wishes of the building's occupants as to an acceptable inside temperature, and according to the prevalent seasonal shift in temperature. For simplicity, the first and second threshold temperatures could be the same.

There could be an Air Source Heat Pump (ASHP) in the fluid flow conduit between the northerly port and the flow diverter for exchanging heat as air either it leaves or enters the building. The ASHP could be supplemented with a heat sink (Thermal Store) for storing heat absorbed by the ASHP from ambient air flowing from the said port from or to the HRU; heat energy stored in this heat sink could be used to heat and provide hot water to a whole building of up to 120m<sup>2</sup> in size, or act as a supplement a larger buildings heat system. If a solar photovoltaic power (PV) system were used to power the ASHP, then this additional heat energy would be effectively "free". In summer when the ASHP is running at a high COP (Co-efficient of Performance) of 3.5 to 4, meaning that for every 1Kw of such "free" energy used to run the ASHP it will produce 3.5 to 4Kw of free heat; this is due to the high ambient air temperatures going through the ASHP as it creates the heat by the use of the energy provided from the PV. The use of stored heat energy from the heat sink can heat the building at night and/or provide all the building's hot water. The ASHP will also work in winter, but less efficiently. The bigger the PV array is the more free heat will be generated.

PV systems are generally more efficient the cooler they get; their electrical output is usually measured when the ambient temperature is 25°C; for every 1°C above this temperature a PV panel will lose approximately 0.5% efficiency – so on an averagely warm day the air temperature can easily reach 45°C, reducing the efficiency of the PV panel by 10% (the same efficiency change applies below 25°C, so in winter or at low ambient temperatures PV panels are more efficient, but in winter there is less solar energy for the PV panels to convert to electricity). In a particularly advantageous arrangement therefore, the PV system may comprise a flat panel array, which is mounted so as to lie in or against but spaced from one of the said pitched slopes of the roof of the building, and so as to overlie, or surround, the port in the slope; the slope would preferably be the most southerly facing slope of those on the pitched roof. This means that in the summer setting, when the

inbound air is drawn from the northerly port and when or if the ASHP is working and cooling the outbound air further, this exhausts the cooled air from the southerly port under the PV array, as the outbound air is somewhat cooler than the ambient temperature, the outbound air cools the PV panels allowing them to operate around 10 to 15% more efficiently.

5           In winter when air is drawn in from the south side there may be means for temporarily reversing the air flows through the MVHR; this would allow the system to pump warm air beneath the PV array, which is helpful in clearing snow which is covering the PV array. There may be directing means for ensuring that the flows of air through the ASHP remain in the same direction regardless of the state of the flow diverter, and the flow  
10   diverter, the ASHP and the directing means may be formed in a single, integral unit.

The invention also provides a method of operating a MVHR system for a building, the system comprising a Heat Recovery Unit (HRU) for receiving and exchanging heat between a flow of ambient air from outside the building and a flow of building air from within the building, the method comprising switching the flows of air between a first state in which  
15   ambient air flows from a first port to the HRU and into the building and building air flows from the HRU to a second port to be exhausted from the building, and a second state in which ambient air flows from the second port to the HRU and into the building and building air flows from the HRU to the first port to be exhausted from the building.

#### BRIEF DESCRIPTION OF THE DRAWINGS

20           The invention will now be described by way of example and with reference to the accompanying figures, in which;

Figure 1 is a schematic view of a domestic house with a typical, conventional Mechanical Ventilation Heat Recovery (MVHR) system;

25           Figures 2a and 2b are schematic views of a house having an MVHR system with a flow diverter in accordance with the present invention, in summer and winter respectively;

Figure 3 is a schematic view of the house of Figure 2 with a roof-mounted solar photovoltaic (PV) array in winter;

Figure 4a is a further schematic view of the house of Figure 3, also in winter, but additionally provided with an Air Source Heat Pump (ASHP) and a heat sink;

Figure 4b is a further schematic view of the house of Figure 4a, in summer;

Figures 5a to d are perspective views of the flow diverter of Figure 2, Figure 5a shows the flow diverter externally, Figure 5b shows the flow diverter without its upper plate to show its internal arrangement, Figure 5c shows the flow diverter without its upper plate or its cylindrical casing to better show the internal arrangement, and Figure 5d shows the movable vane arrangement which is inside the flow diverter;

Figure 6a is a perspective line view of a unit comprising a flow diverter, a transition drum and an ASHP, and Figure 6b is a schematic view of a unit similar to that of figure 6a but with a different arrangement of inlet and outlet ports, and

Figures 7a to c show the operation of the unit of Figure 6a.

#### DETAILED DESCRIPTION OF THE EMBODIMENTS

Figure 1 shows a domestic house 2 equipped with a typical MVHR system; the house has a pitched roof having two pitched slopes, one slope 4 on a northerly facing side of the house and a second slope 6 on the opposite, southerly facing side of the house. The MVHR system comprises a Heat Recovery Unit HRU which is connected by air flow ducting 8 to a port 10 on the north slope 4 of the roof, and by air flow ducting 12 to a port 14 on the south slope 4 of the roof. Arrows in the drawing show the air flows within the MVHR system. The HRU is provided with fans to draw warm, humid air from the kitchen, bathroom and toilet in the house and to exhaust this outbound air through conduit 8 and port 10 out of the house. Air passageways or ducts 16 are provided to direct the flows of air inside the house. Fans in the HRU also draw fresh, ambient air (inbound air) from outside the house, through port 14 and conduit 12 and into the bedrooms and living room in the house. The HRU also includes heating/cooling means (not shown) for heating or for cooling the inbound air so that it enters the living room and bedrooms at a comfortable temperature. In addition, the HRU is configured such that the flows of inbound and outbound air pass each other, usually in opposite directions, in an arrangement which facilitates heat exchange between the two air flows; this heat exchange arrangement is intended to supplement the means for heating or cooling the inbound air and thus reduce overall energy usage (although note that all MVHR systems have a bypass operable in summer to avoid warm air leaving the house from

heating the air entering; this summer bypass is usually actuated when the air temperature entering the unit reaches 18°). In winter, when the sun is shining on the southerly roof slope 6, ambient air around port 14 is likely to be at a higher temperature than ambient air surrounding port 10 in northerly slope 4; as inbound air passes through the HRU, it is warmed further by heat exchange with the warm outbound air leaving the kitchen, bathroom and toilet, thus reducing the energy required to bring the temperature of this inbound air to the desired comfortable level to be blown into the living room and bedrooms. In summer, however (which is what is illustrated in Figure 1), the air which enters through port 14 is likely to be much warmer than the air surrounding port 10, and is probably also warmer than the air to be exhausted from within the house; whilst this inbound air can be cooled to an extent through heat exchange in the HRU, it will need to be cooled further by the heating/cooling means to bring it to a temperature which is comfortable to the house's occupants. Because the inbound air is drawn from the warmer, southern side of the house it will require more energy to cool it than would be required if the inbound air were drawn from the cooler, northern side of the house. But it would not be feasible to reverse the flow of air through the MVHR system, as this would lead to inbound air entering into the house in the kitchen, bathroom and toilet, and outbound air being drawn from the living room and bedrooms – this would mean that humid air carrying cooking and other smells would be drawn through other, occupied parts of the house before being exhausted from the house, which would not be pleasant for the occupants. It will be appreciated also that, were the arrangement to be such that the inbound air were drawn in through port 4 on the north side of the house and outbound air exhausted from port 14 on the south side of the house, whilst this would lead to reduced energy usage by the heating/cooling means in adjusting the inbound air flow temperature to what is comfortable (i.e. cooling the inbound air flow) in summer, in winter when ambient air temperature is low generally, but lower on the north side of the house than on the southern, sun-facing side of the house, then the heating/cooling means would require more energy to bring the inbound air temperature to a comfortable level than if it were drawn from the south side of the house. It will also be appreciated that there are often temperature fluctuations which run counter to seasonal norms – an unusually warm day during winter, or an unusually cold day in summer – and that however the MVHR system is installed (it is usually built into the house and is as static a part of the house as are radiators and the associated plumbing, for example) the MVHR system will use more energy than theoretically it needs.

MVHR systems in accordance with the invention are predicated on the concept of reversing the air flows in only a part of the system. In the system shown in Figure 2a (which shows a house 2 with an MVHR system in the summer), a flow diverter 20 is located in the air flow ducting 8, 12 between the HRU and the ports 10, 14. Inbound air is drawn in through the port 10 on the northern slope 4 of the roof, flows along the ducting 8, through the flow diverter 20 and the HRU and into the house via internal passageways 16. Stale air is drawn into the passageways from the kitchen, bathroom and toilet and flows to the HRU, through the flow diverter 20 and the ducting 12 to exhaust from the port 12 on the southern slope 6 of the roof. In this example, the air to the north of the roof is cooler than the air to the south, so the heating/cooling unit has less work to do to reduce the temperature of the air pumped into the house to what is desirable/comfortable for occupants of the house (compared to drawing inbound air through port 12).

Referring now to Figure 2b, the same system is shown in the winter, and it can be seen that the flows of inbound and outbound air between the HRU and outside the house are reversed compared to those same flows in Figure 2a: inbound air is drawn in through the port 14 on the southern slope 6 of the roof, flows along the ducting 12, through the flow diverter 20 and the HRU and into the house via internal passageways 16. Stale air is drawn into the passageways from the kitchen, bathroom and toilet and flows to the HRU, through the flow diverter 20 and the ducting 8 to exhaust from the port 10 on the northern slope 4 of the roof. In this example, the air to the south of the roof is warmer than the air to the north, so the heating/cooling unit has less work to do to increase the temperature of the air pumped into the house to what is desirable/comfortable for occupants of the house (compared to drawing inbound air through port 10).

It will be appreciated that not all buildings are precisely aligned north-south; nevertheless in any building having a pitched roof with two or more pitched slopes there will be one slope which tends to be warmer – the one which is generally more south facing - and one which tends to be cooler - the one which is generally more north facing, and in installing an MVHR system in accordance with the invention the ports would normally be located in these slopes (the ones with the greatest temperature variation) in order to optimise the efficiency of the system. Moreover it will be understood that the system can operate to save energy other than seasonally (e.g. on a hot day in winter, or a cold day in summer), and all that is necessary is a suitable set of sensors, to measure the temperature



inside the house, and/or outside the house, with a controller set to actuate the flow controller either when the external temperature passes a certain threshold, or when the temperature difference reaches a certain value. In this way, the system can ensure that the MVHR system is operating at its optimum efficiency for the temperature at any particular time. In practice we have found that setting an ambient temperature of 16° C as the threshold, so that the flow diverter changes the air flows as the ambient temperature increases or reduces past that temperature, represents a simple threshold which is suitable for homes in the climate of the United Kingdom. Other threshold temperatures may be appropriate in other climates, as will be understood by those skilled in the art.

Figure 3 shows how the present invention can provide yet further advantages; the house 2 is shown in winter, with the flow diverter arranged so that inbound air flows in through port 14 on the warm slope 6 to the south of the house and outbound air is exhausted from the port 10 on the opposite side of the roof. A solar photovoltaic (PV) array 22, comprising one or more panels is mounted to the slope 6, so as to capture the maximum amount of solar energy. Air in the gap 24 between the PV array 22 and the roof slope 6 is still, being sheltered from wind, etc. by the smallness of the gap 24, and is warmed by radiation and conduction from the PV array 22, to a temperature higher than that of the air a greater distance away from the slope 6 (on a sunny day, the temperature difference between the air trapped in the gap 24 and that further away from the house can be as much as 20° C), and this "pre-warming" of the inbound air not only adds to the energy saving of the heating means, it also helps lower the temperature of the panels in the PV array 22, which increases the efficiency at which they transform radiant energy into electrical power, which is very advantageous. In practice, making the PV array as large in area as possible, with no air gaps between individual panels making up the array, provides the best performance in this respect (though of course this should be tempered by the size of the gap 24, so as not to put an excessive load on the HRU fans working to draw inbound air into the building).

On occasion in winter the PV array 22 will become wholly or partially covered by snow, which will reduce its ability to generate useful electricity. In such circumstances the flow diverter could be directed to reverse the flow of air through the MVHR system, so that inbound air is drawn through the northerly port 10 and relatively warm outbound air is exhausted via the port 14 beneath the PV array; this warm air heats the PV array 22 and

melts the snow resting on top of the PV array. The flow is diverted in this way until the snow is cleared. Operation of the MVHR system in this way to clear snow could be manually actuated, possibly with the flow being diverted for a predetermined time before it reverts to the flow arrangement of Figure 4, or it could be automatic, with sensors to detect the presence of snow on the PV array (this could be done by knowing that it was daylight (using a separate daylight sensor, or a clock, for example) but sensing that the PV array was not generating electricity; if this situation arose in summer, the system could actuate a warning message, in winter it could be assumed that the PV array is covered by snow and/or ice, and the clearance process described above actuated).

Figure 4a shows the system of Figure 3 with the addition of an Air Source Heat Pump (ASHP) 26 to recover heat energy from the outbound air before it leaves the building. The air flow ducting 8 to the north side of the house is split into two parts, 8' and 8'', so that the outbound air flows through the ASHP 26. The ASHP acts to remove heat energy from the outbound air in the known manner, so that the outbound air is exhausted at a temperature much closer to ambient outside temperature; the extracted heat energy may be released inside the building, as hot water-filled radiators, underfloor heating and/or domestic hot water supply, etc., or it can be conducted to a heat sink 28 where it is stored for future use. The working fluid from the ASHP to the heat sink circuit 30 is circulated by a single pump 32 that moves the hot water produced by the ASHP to the heat sink which, most advantageously, is powered with electricity from the PV array 22. We estimate that under the normal conditions in the United Kingdom (and ignoring equipment and installation costs) such a system can provide free heat for up to 8 to 9 months of the year – in the winter months, when solar energy is insufficient, the pump 32 can be powered from another source. The ASHP will come on automatically when the PV array is producing more power than the house is using and storing it for later, or if the ASHP is designed to heat the house as well and if there is not enough stored free heat, it will come on when there is a heat or hot water demand in the property.

Figure 4b shows the system of Figure 4a operating in summer. Here, the flows in the air flow ducting 8, 12 is reversed compared to Figure 4a, so inbound air is drawn in through the air flow ducting 8'', 8' on the cooler north side passes through the ASHP 26, then the flow diverter 20, the HRU and into the house. It will be noted that the ducting 8', 8'' is reversed as it leads into the ASHP. This is because the flow through the ASHP must always

be in the same direction for the ASHP to function. This reversal of the ducting is described further below, in connection with Figures 6 and 7. Through its refrigerant cycle when heating the hot water or heat sink, the ASHP extracts heat energy from the already cool air on the north side of the house to cool it a little more, and the heating/cooling means in the HRU cools the inbound air to the desired degree before it is pumped into the building. The outbound air flows through the HRU, the flow diverter 20 and the air flow ducting 12 to exit the building into the gap 24 between the southern slope of the roof and the PV array. Because this air is cooler than the ambient air, this cools the rear of the PV array, thereby enabling it to operate more effectively and providing further efficiency.

10            Figures 5a to d are four perspective views of the flow diverter 20 of Figures 2 to 4. Figure 5a is an external view of the flow diverter, Figure 5b shows the flow diverter with the top plate removed, Figure 5c shows the flow diverter with both the top plate and the cylindrical casing removed to show the inner workings of the flow diverter, and figure 5d shows the inner vane mechanism. The flow diverter is generally airtight and comprises a generally cylindrical casing 50 which is closed at its ends by a top plate 52 and a bottom plate 54 (shown in Figure 5c). There are 4 ports 56a-d provided in the top plate 52, for connecting the flow diverter 20 between the HRU and the air flow ducting 8, 12. Inside the casing 50 is a vane mechanism 60 which comprises a fixed frame portion 62 and a rotatable vane 64; the fixed frame portion 62 is mounted fixedly to the interior of the casing 50 and the top and bottom plates 52, 54. The upper part of frame 62 runs between the four ports 56a-d so as to separate them into two pairs (shown as 56a and 56d in one pair, and 56b and 56c in the other pair). Vane 64 is rotatable about spindle 66 between a first position in which it is parallel to frame 62 and a second position in which it is perpendicular to frame 62; the arrangement is substantially airtight at both positions to ensure the flow of air is as intended, but during movement in between these end positions it is not completely airtight, instead there is a small gap (about 5mm or less) between the edges of the vane 64 and the cylindrical casing 50 and top and bottom plates 52, 54 so that the air does not restrict the vane from moving freely (because a small amount of air can flow around the edges of the vane 64 as it moves) and so that any minor damage, dents, etc. to the flow diverter do not impede the movement of the vane. Movement of the vane is actuated by mechanism 58, which rotates the vane back and forth under the control of an automatic controller (not shown) which is responsive to the input desired temperature within the house (which can be set by way of a thermostat, or other similar device) and the external ambient temperature.

We envisage the vane taking about 20 seconds to move between positions. In the first position, where vane 64 lies against and parallel to frame 62, air can only flow between port 56a and 56d, and between port 56 b and port 56 c. In the second position, where vane 64 is rotated so as to be perpendicular to frame 62 (as clearly shown in Figures 5c and 5d), air can only flow between port 56a and port 56b, and between port 56c and port 56d. Thus by switching the vane 64 between the first and second positions the flow diverter can change the flow directions in air flow ducting 8, 12 without affecting the air flow directions in the other parts of the MVHR system. The flow diverter is in effect a 4/2 directional control valve, however the large volume within the casing 50 is advantageous over a plain valve because this volume acts as a noise attenuating plenum, preventing noise from the MVHR system from leaking outside the building, and preventing noise from the flow diverter from entering the building. In practice, the flow diverter would be insulated, internally and externally, to reduce noise and condensation.

Referring back to Figures 4a and 4b, it will be appreciated that some form of flow diverter for the flows of inbound and outbound air to/from the AHSP would be desirable; the units 68, 68' illustrated in Figures 6 and 7 provide just such an arrangement. In Figure 6a, the flow diverter 20 sits above a transition drum 70 which in turn sits atop an ASHP, the joins between the three elements being substantially airtight and forming a single unit 68. The top of the transition drum 70 may be the bottom plate 54 of the flow diverter, so that the two may be manufactured as one unit. In Figure 6b, the flow diverter 20' has a different arrangement of inlet and outlet ports 56a' to 56d' (they are arranged around the circumferential casing 50, rather than on the top plate 52) but otherwise the unit 68' in Figure 6b is the same as the unit 68 in Figure 6a, and they operate in the same manner. There are ports (not shown) in the bottom plate of the flow diverter 20, 20' which communicate with ports on the top of the transition drum 70, which communicates in turn with ports in the top of the ASHP (inlet port 72 (through which air flows into the ASHP) and outlet port 74 (from where air exhausts from the ASHP)). The ASHP has a built in fan (not shown) that sucks and blows the air through the unit 68, 68' so it does not rely on the air flow generated by the MVHR to work. The flow diverter 20, 20' together with the transition drum 70 ensures that the air entering the ASHP always enters through port 72 and leaves through port 74.

Figures 7a and 7c show the unit 68 in the summer setting, and Figure 7b shows the unit 20 in the winter setting; the curved arrows show the direction of the air flows through the unit.

The transition drum 70 is divided internally into separate chambers by baffles B, the chambers occupying one half 76 of the transition drum 70, and two quadrants 78, 80; one chamber 78 has a port 82 directly under the port 56a of the flow diverter 20 which leads to the MVHR. This port 82 is directly over the inlet port 72 of the ASHP, so the air always enters the ASHP no matter which side of the roof the air is coming in from, north or south, this is done automatically as the flow diverter 20 switches. The other quadrant chamber 80 is empty, and may contain control electronics for the system. The half chamber 76 has two ports 84, 86 beneath ports 56c and 56d respectively. The air leaving the ASHP leaves through the other port 74 on the opposite side of the transition drum 70. This is no problem when in winter setting however in summer setting the cold air leaving mixes directly with the fresh air entering (which could make the air entering the ASHP colder and colder), see Figure 7c showing ports 82, 84. To ensure the air entering the house does not get continually colder and as we want to both cool the incoming air to the house and cool the PV array at the same time there are two ports for this; one 84 communicates with the flow diverter 20 at the bottom under the port 56d and the other port 82 communicates directly with port 56c, so the air flow from there cools the PV. The port 84 has a one-way valve ensuring the air being removed does not mix when the unit is in the summer setting and the ASHP is off. The volumes in chambers 76 and 82 adds to the plenum effect described above in connection with the flow diverter 20.

It will of course be understood that many variations may be made to the above-described embodiments without departing from the scope of the present invention. For example, the flow diverter ports 56a-d could be located on the cylindrical casing 50 rather than on the top plate 52. The system could be used in a building with a flat roof, but this would require the air ports to be located such that the air in their vicinity was likely to be at different temperatures, such as by mounting them on different sides of the building (the air ports could not be on the roof, since being flat the air above this would be all at the same temperature). The system may be automatically controlled so as to switch flow direction at one temperature when the ambient temperature is rising, and to switch flow direction again at a second temperature different from the first temperature when the outside temperature

is falling. Alternatively there may be just a single threshold temperature at which the actuator mechanism 58 is prompted to move the vane between the two positions. Although described with reference to a home or domestic building, the invention is not limited to buildings of any particular function or size, and it is equally as applicable to large commercial buildings. Additional implementation details and straightforward variations or modifications will be apparent to those skilled in the art.

Where different variations or alternative arrangements are described above, it should be understood that embodiments of the invention may incorporate such variations and/or alternatives in any suitable combination.

CLAIMS

1. A Mechanical Ventilation Heat Recovery (MVHR) system for a building having a roof with at least two pitched slopes facing in different directions, the MVHR system comprising a Heat Recovery Unit (HRU) for receiving and exchanging heat between a flow of ambient air from outside the building and a flow of building air from within the building, the HRU being connected by fluid flow conduits to first and second ports located on different pitched slopes, in which a flow diverter is provided in the conduits between the HRU and the ports, the flow diverter being switchable between a first state in which ambient air flows from the first port to the HRU and into the building and building air flows from the HRU to the second port to be exhausted from the building, and a second state in which ambient air flows from the second port to the HRU and into the building and building air flows from the HRU to the first port to be exhausted from the building.
2. An MVHR system according to Claim 1 in which the ports are located on pitched slopes which face in opposite directions.
3. An MVHR system according to Claim 1 or 2 in which the flow diverter is adapted to switch the flows of ambient and building air between the first and second states simultaneously.
4. An MVHR system according to Claim 1, 2 or 3 in which the flow diverter incorporates a separate plenum for each flow of air, into and out of the building, to flow through.
5. An MVHR system according to any preceding claim in which the flow diverter comprises a generally cylindrical drum having four ports for air to flow through located on at least one end face of the drum, the drum containing a rotatable vane, the ports being disposed such that rotation of the vane within the drum switches air flows between the first and second states, or *vice versa*.
6. An MVHR system according to any preceding claim comprising a sensor for determining the ambient temperature outside the building, and a controller adapted to switch the flow diverter from the first state to the second when the ambient temperature exceeds a first threshold temperature.

7. An MVHR system according to Claim 6, in which the controller is adapted to switch the flow diverter from the second state to the first when the ambient temperature is less than a second threshold temperature.
- 5 8. An MVHR system according to Claim 7, in which the first and second threshold temperatures are the same.
9. An MVHR system according to any preceding claim, further comprising an Air Source Heat Pump (ASHP) in the fluid flow conduit between one of the ports and the flow diverter for exchanging heat between ambient air and building.
- 10 10. An MVHR system according to Claim 9, further comprising a heat sink for storing heat absorbed by the ASHP from ambient air flowing from the said port to the HRU.
11. An MVHR system according to Claim 9 or 10, further comprising a solar photovoltaic power (PV) system for powering the ASHP.
12. An MVHR system according to any of Claims 9 to 11 comprising means for temporarily reversing the flows through the MVHR.
- 15 13. An MVHR system according to any of Claims 9 to 12 further comprising directing means for ensuring that the flows of air through the ASHP remain in the same direction regardless of the state of the flow diverter.
14. An MVHR system according to Claim 13 in which the flow diverter, the ASHP and the directing means form a single unit.
- 20 15. A building comprising an MVHR system according to Claim 11, in which the PV system comprises a flat panel array, which is mounted so as to lie against but spaced from one of the said pitched slopes of the roof of the building, and so as to overlie the port in the slope.
- 25 16. A building comprising an MVHR system according to Claim 12, in which the PV array comprises a plurality of separate PV panels connected together in a flat structure, in which the adjoining edges of adjacent panels are joined so as to prevent airflow between the panels.



17. A method of operating a MVHR system for a building, the system comprising a Heat Recovery Unit (HRU) for receiving and exchanging heat between a flow of ambient air from outside the building and a flow of building air from within the building, the method comprising switching the flows of air between a first state in which ambient air flows from a first port to the HRU and into the building and building air flows from the HRU to a second port to be exhausted from the building, and a second state in which ambient air flows from the second port to the HRU and into the building and building air flows from the HRU to the first port to be exhausted from the building.
- 5



**Application No:** GB1704509.7

**Examiner:** Dr Rhys Williams

**Claims searched:** 1-17

**Date of search:** 16 May 2017

**Patents Act 1977: Search Report under Section 17**

**Documents considered to be relevant:**

Category	Relevant to claims	Identity of document and passage or figure of particular relevance
X	17	EP 0536445 A1 (CA BYGG AB) See whole document.
A	-	EP 1923643 A2 (POLYPIPE BUILDING PRODUCTS) See Fig. 1, paragraph [0023].

**Categories:**

X	Document indicating lack of novelty or inventive step	A	Document indicating technological background and/or state of the art.
Y	Document indicating lack of inventive step if combined with one or more other documents of same category.	P	Document published on or after the declared priority date but before the filing date of this invention.
&	Member of the same patent family	E	Patent document published on or after, but with priority date earlier than, the filing date of this application.

**Field of Search:**

Search of GB, EP, WO & US patent documents classified in the following areas of the UKC<sup>X</sup> :

Worldwide search of patent documents classified in the following areas of the IPC

F24F

The following online and other databases have been used in the preparation of this search report

EPODOC, WPI, Patent Fulltext

**International Classification:**

Subclass	Subgroup	Valid From
F24F	0012/00	01/01/2006