



US00D661603S

(12) **United States Design Patent**  
**MacKay et al.**

(10) **Patent No.:** **US D661,603 S**

(45) **Date of Patent:** **\*\* Jun. 12, 2012**

(54) **SINGLE SPACE PARKING METER**

(75) Inventors: **George Allan MacKay**, New Glasgow  
(CA); **Shamus John Angus McLarty**,  
Halifax (CA)

(73) Assignee: **J.J. MacKay Canada Limited** (CA)

(\*\*) Term: **14 Years**

(21) Appl. No.: **29/410,857**

(22) Filed: **Jan. 12, 2012**

**Related U.S. Application Data**

(63) Continuation-in-part of application No. 29/391,605,  
filed on May 11, 2011.

(51) **LOC (9) Cl.** ..... **10-03**

(52) **U.S. Cl.** ..... **D10/42**

(58) **Field of Classification Search** ..... D10/42;  
368/90, 92; 194/900, 902, 217

See application file for complete search history.

(56) **References Cited**

**U.S. PATENT DOCUMENTS**

D107,577	S	*	12/1937	McGay	.....	D10/42
2,289,838	A	*	7/1942	Herschede et al.	.....	194/226
2,599,881	A	*	6/1952	Woodruff	.....	368/92
D181,359	S	*	11/1957	Jones	.....	D10/42

3,486,324	A	*	12/1969	Andersson	.....	368/90
5,109,972	A	*	5/1992	Van Horn et al.	.....	194/217
5,841,369	A	*	11/1998	Sutton et al.	.....	340/932.2
RE37,193	E	*	5/2001	Ward et al.	.....	194/217
D575,168	S	*	8/2008	King et al.	.....	D10/42
D587,141	S	*	2/2009	King et al.	.....	D10/42
7,854,310	B2	*	12/2010	King et al.	.....	194/350
2009/0159674	A1	*	6/2009	King et al.	.....	235/382

\* cited by examiner

*Primary Examiner* — Lucy Lieberman

(74) *Attorney, Agent, or Firm* — Hayes Soloway P.C.

(57) **CLAIM**

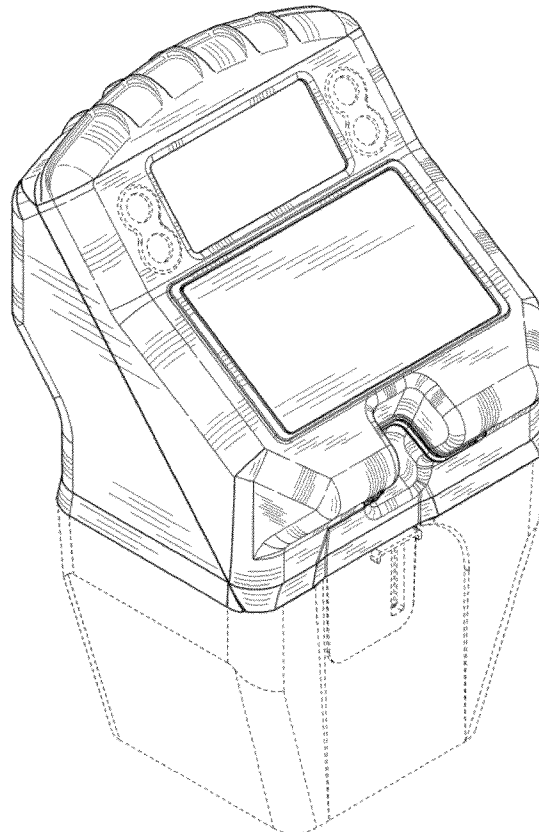
The ornamental design for a single space parking meter, as shown and described.

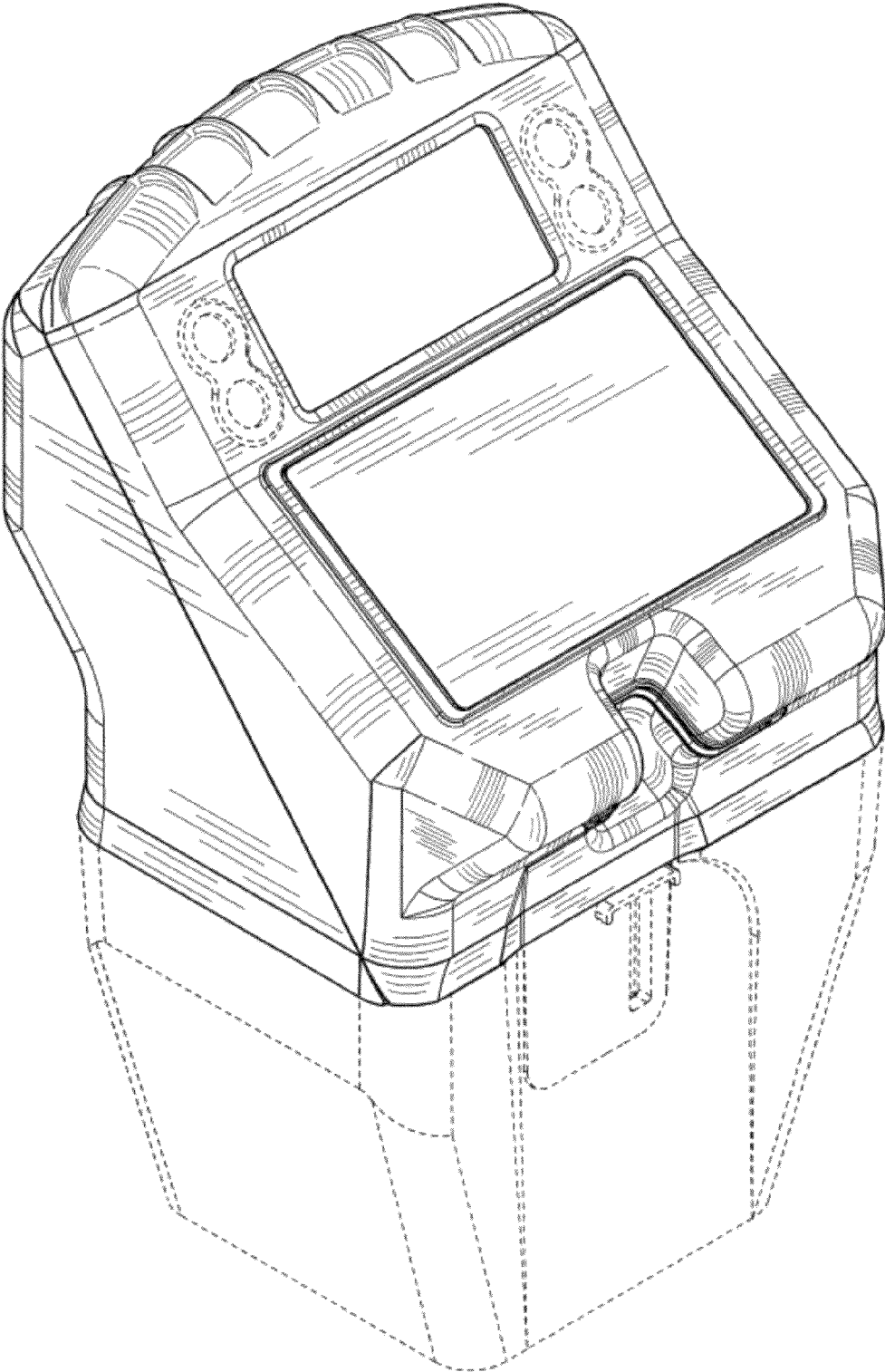
**DESCRIPTION**

FIG. 1 is a top front left perspective view of a single space parking meter showing the new design; FIG. 2 is a top back right perspective view thereof; FIG. 3 is a left side elevation view thereof; FIG. 4 is a front elevation view thereof; FIG. 5 is a right side elevation view thereof; FIG. 6 is a back elevation view thereof; and, FIG. 7 is a top plan view thereof.

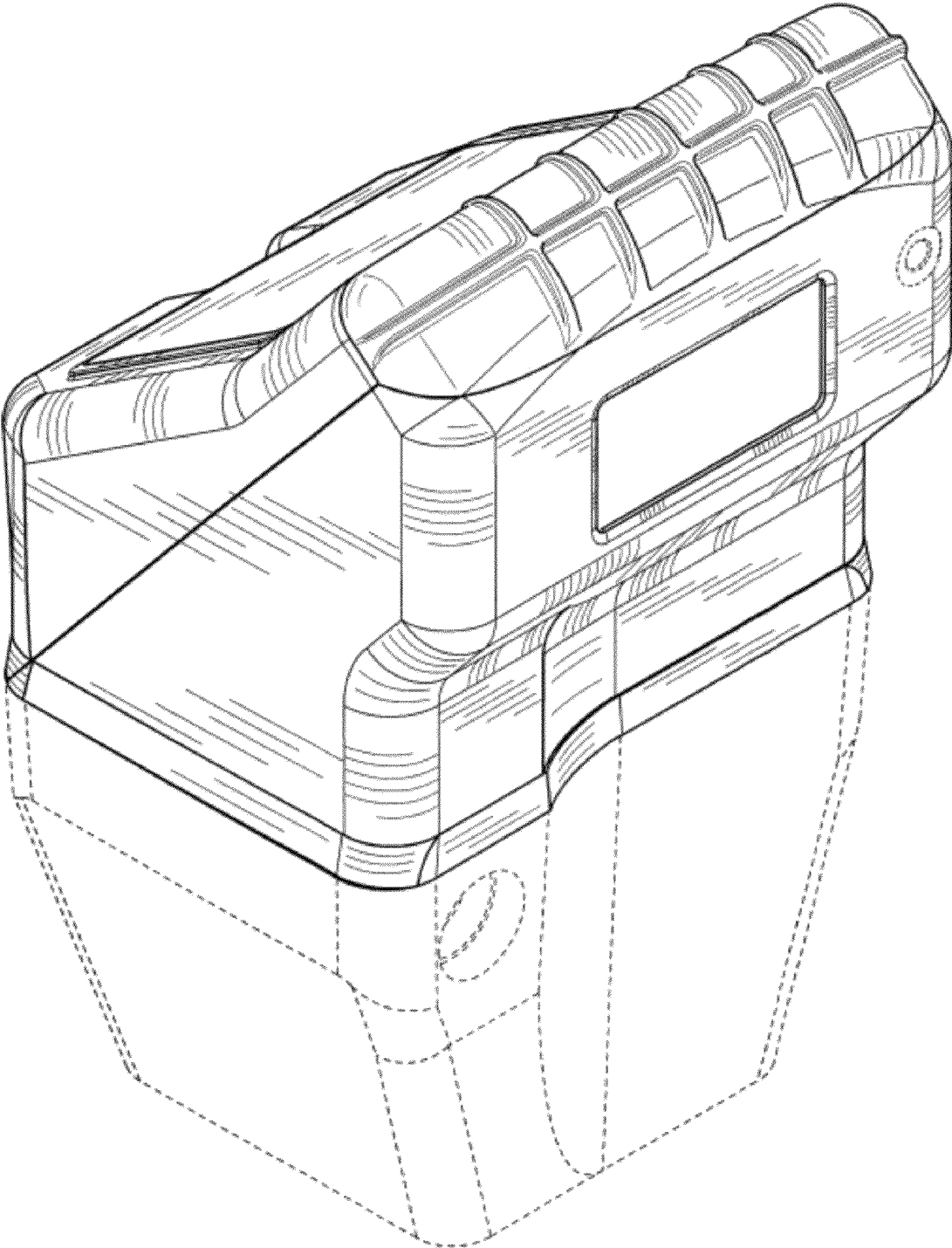
The broken lines are for environmental purposes only and form no part of the claimed design.

**1 Claim, 7 Drawing Sheets**

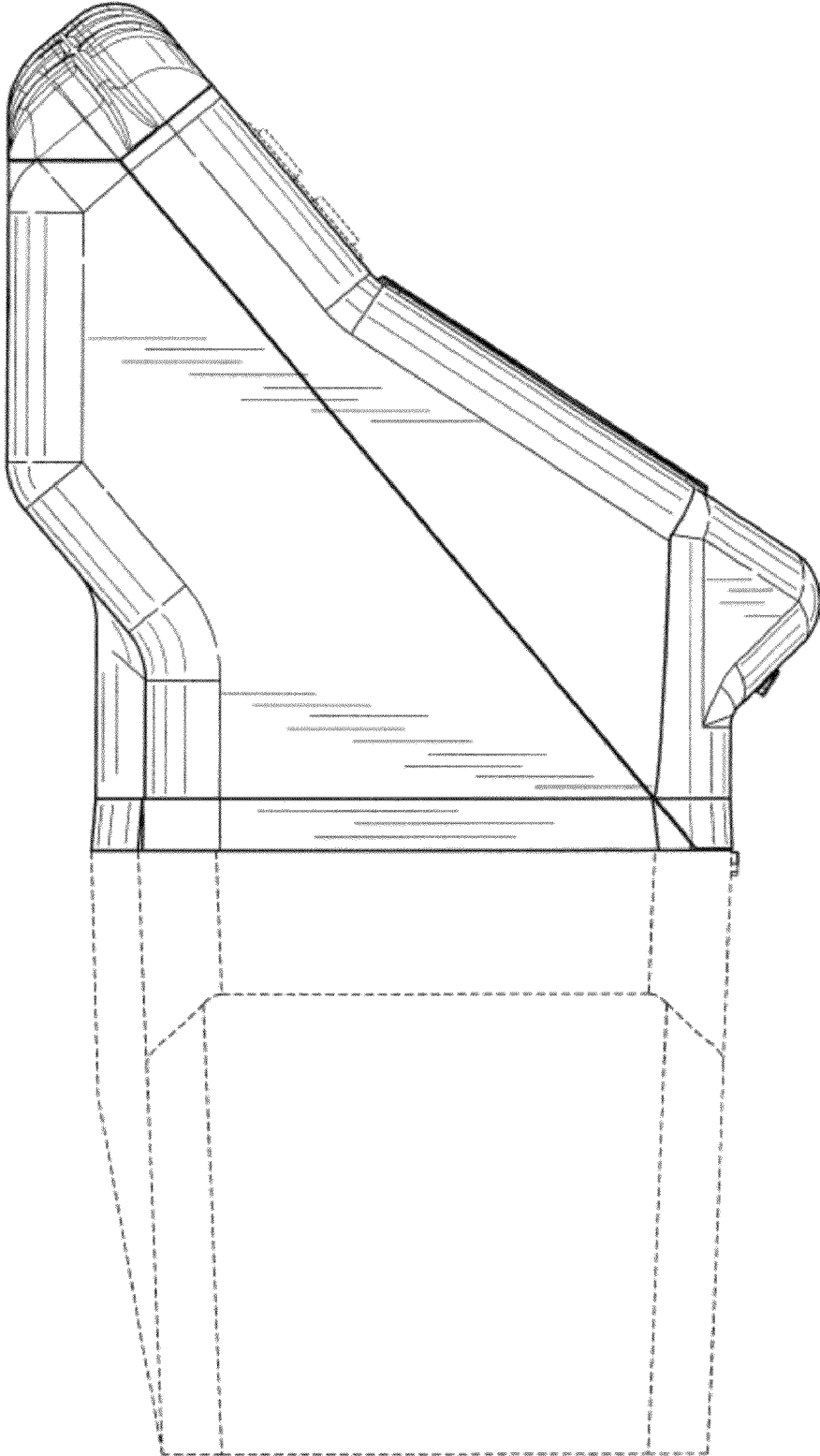




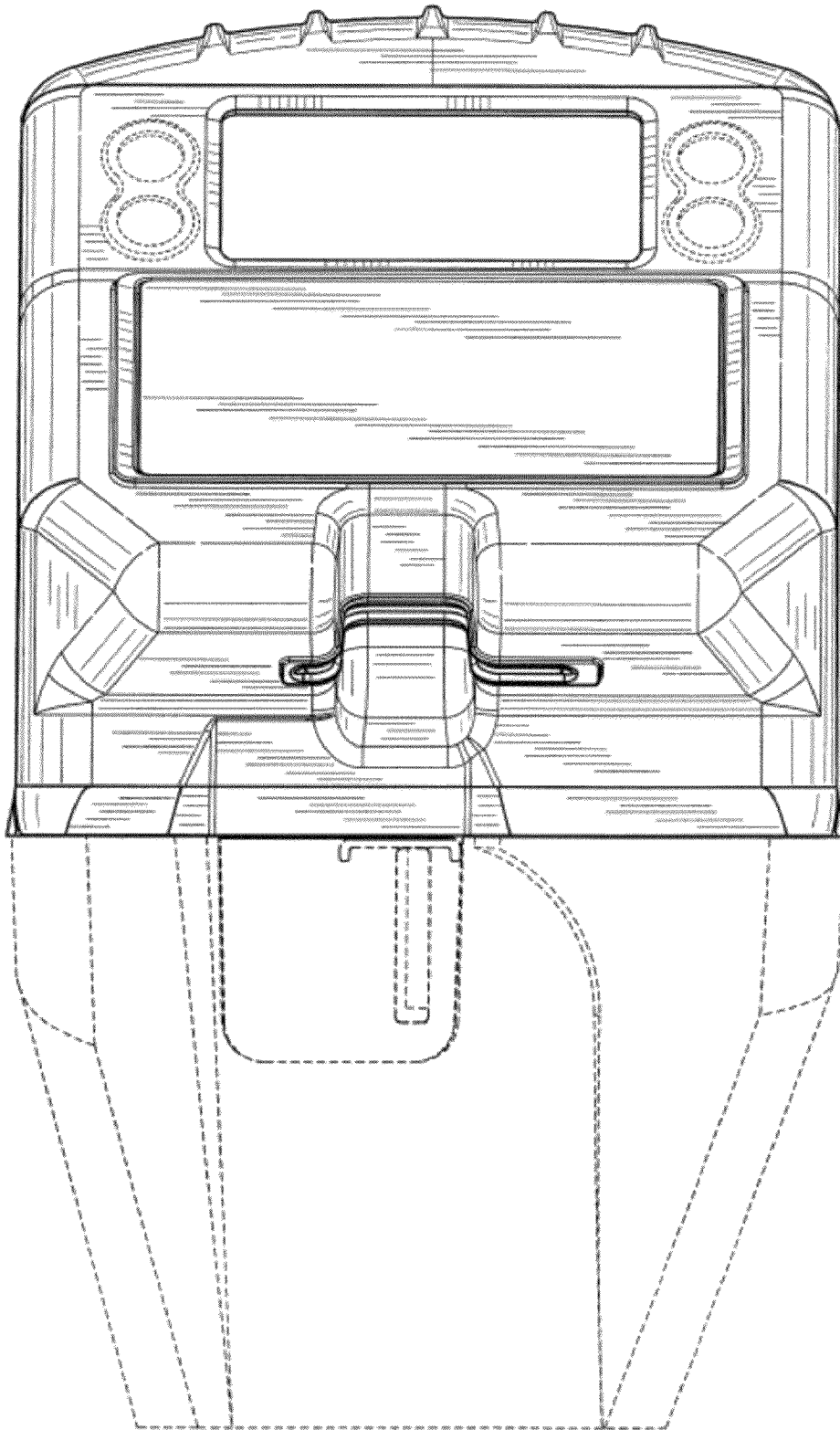
**FIG. 1**



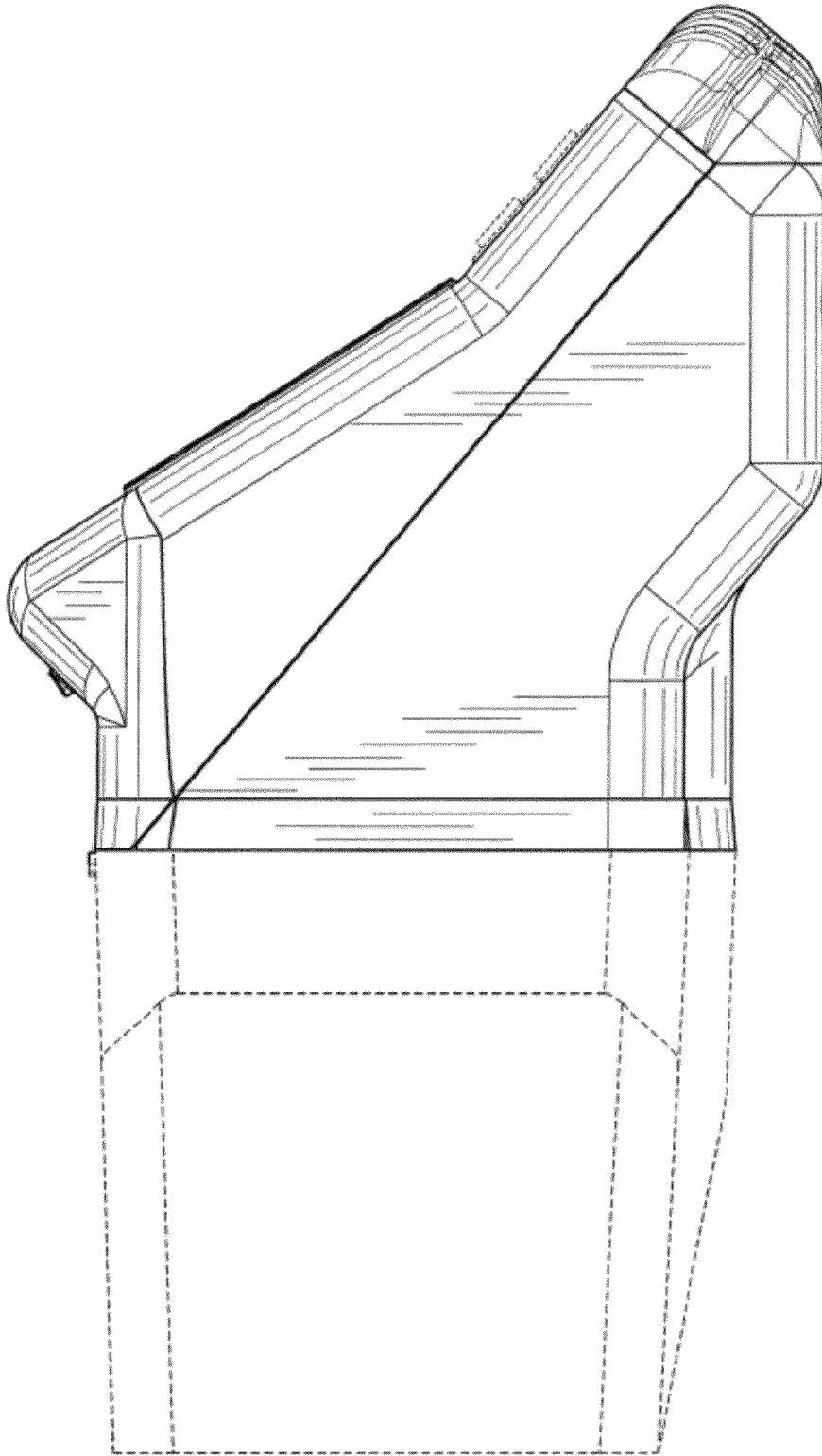
**FIG. 2**



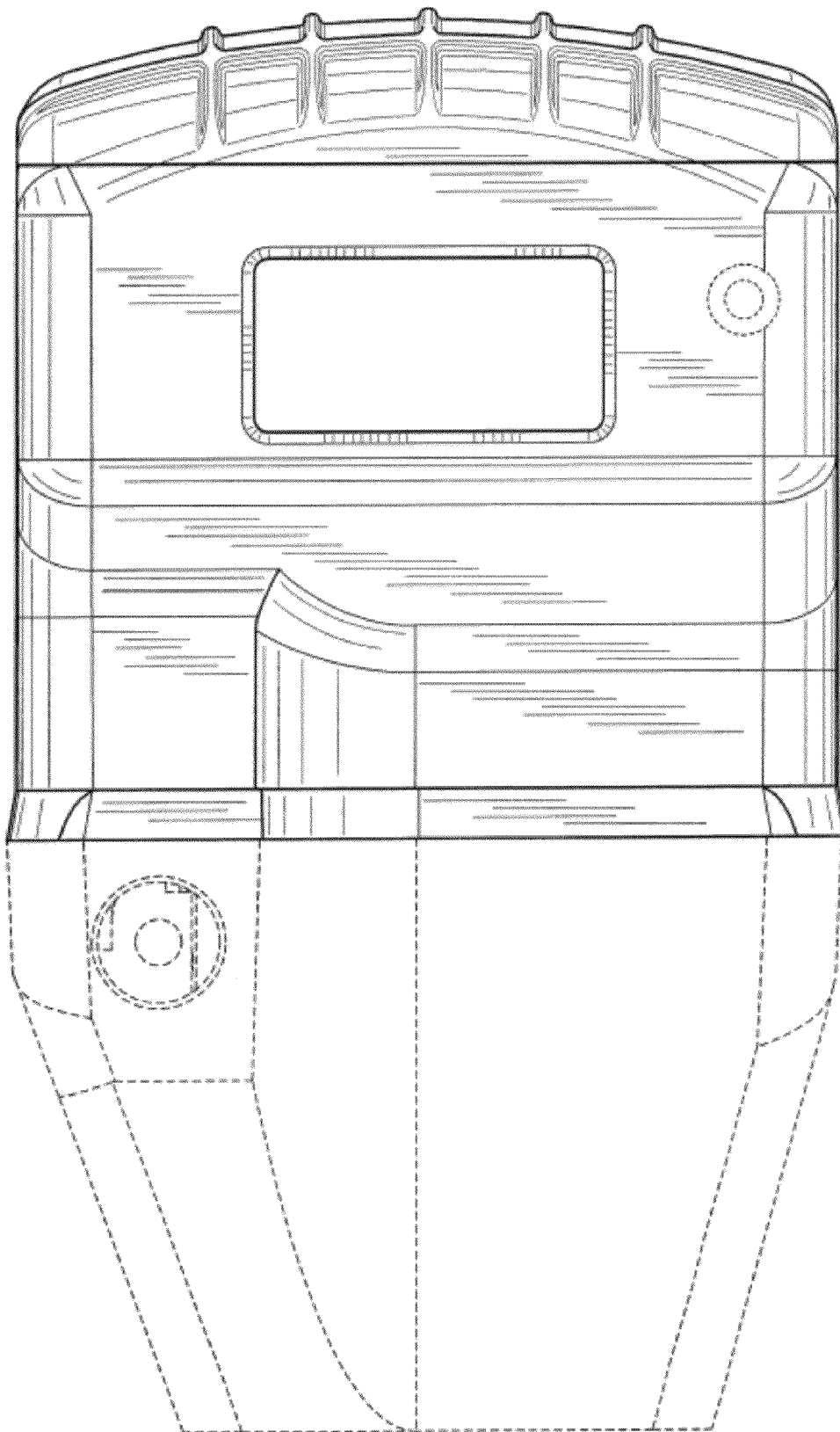
**FIG. 3**



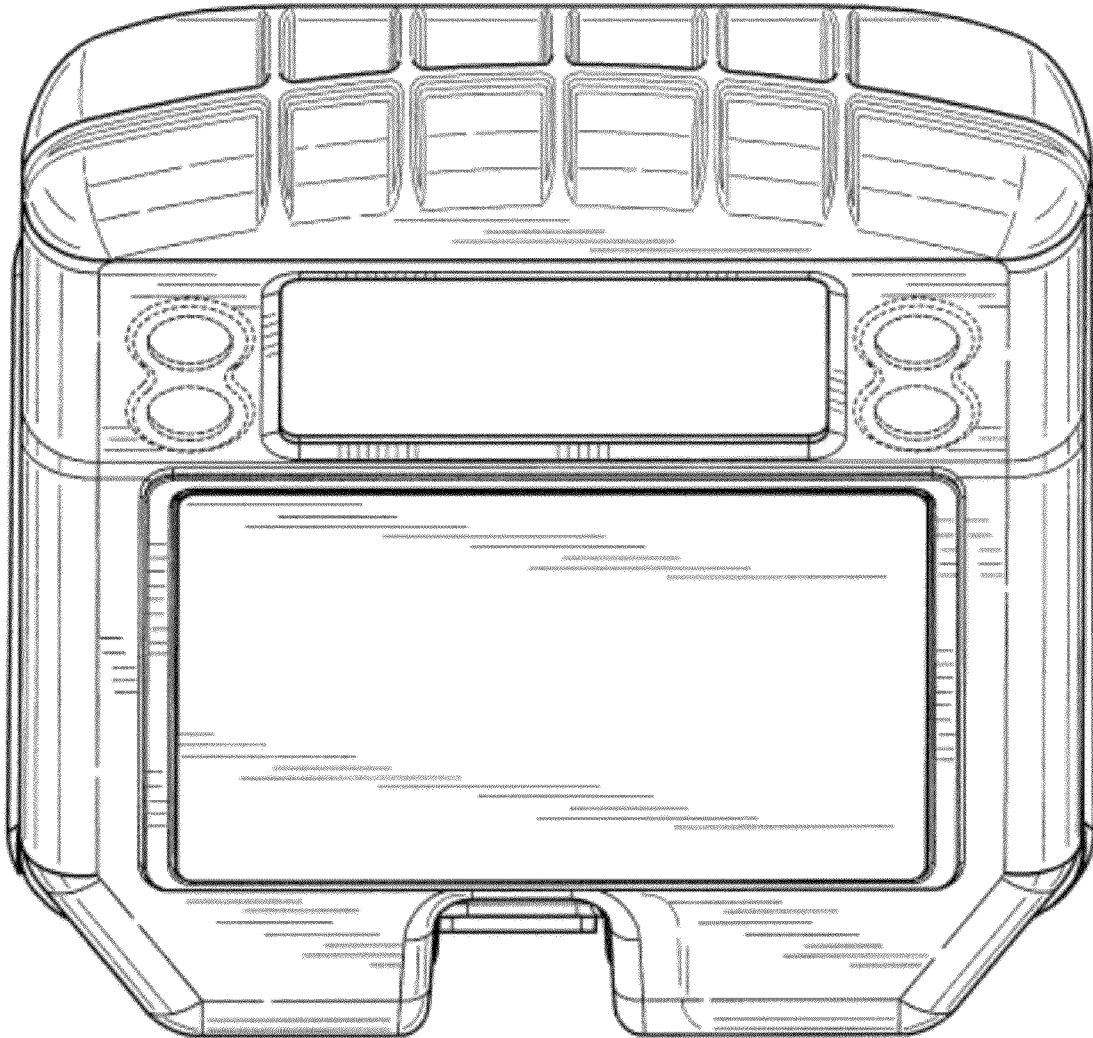
**FIG. 4**



**FIG. 5**



**FIG. 6**



**FIG. 7**