



Europäisches Patentamt  
 European Patent Office  
 Office européen des brevets



(11) **EP 1 677 267 A1**

(12) **EUROPEAN PATENT APPLICATION**

(43) Date of publication:  
**05.07.2006 Bulletin 2006/27**

(51) Int Cl.:  
**G07F 19/00 (2006.01)**

(21) Application number: **04380296.6**

(22) Date of filing: **30.12.2004**

(84) Designated Contracting States:  
**AT BE BG CH CY CZ DE DK EE ES FI FR GB GR  
 HU IE IS IT LI LT LU MC NL PL PT RO SE SI SK TR**  
 Designated Extension States:  
**AL BA HR LV MK YU**

(72) Inventor: **Ghisani, Rolando Roberto  
 Buenos Aires (AR)**

(74) Representative: **Naranjo Marcos, Maria Antonia  
 Paseo de la Habana 200  
 28036 Madrid (ES)**

(71) Applicant: **Firpo Polledo, Luis Juan  
 Buenos Aires (AR)**

Remarks:

Amended claims in accordance with Rule 86 (2) EPC.

(54) **Electronic security device for automated teller machines and card reader driver including such device**

(57) AN ELECTRONIC SECURITY DEVICE FOR AUTOMATED TELLER MACHINES AND A CARD READER DRIVER INCLUDING SUCH DEVICE. This electronic device comprises an optoelectronic sensing barrier (7) transversely aligned to the card-in/card-out passage (4), further comprising an electronic circuit (10) which is connected to said sensing barrier (7); and providing comparator means (13) (17) and timers (14) (15)

(16); and including one or more emergency or alarm signal outputs (18) responsive to the insertion of foreign bodies which, when inserted in the passage (4) pass through the sensing barrier (7). This device can include a secondary barrier (8) in the rear part of the passage (4). The present invention further related to a card reader driver (1) including such device.

**EP 1 677 267 A1**

**Description****I - BACKGROUND OF THE INVENTION**TECHNICAL FIELD

[0001] This invention relates to the field of banking security. Specifically, this invention relates to automated teller machines.

[0002] More specifically, this invention relates to an electronic security device based on an optoelectronic sensing barrier aligned transversely to the passage of transaction cards and a card reader driver including such device.

BACKGROUND ART

[0003] It is known that ATM (Automated Teller Machines) or automated transaction machines are devices that allow to perform bank transactions. For this purpose, ATMs have a plurality of means enabling to carry out transactions based on the recognition of valid cards that the user inserts in the input/output card slot.

[0004] Furthermore, it is known that permanent fraud attempts are performed by criminals who try to seize bank funds. For this purpose, thieves may run card trapping scams usually called card traps. Such card-trapping devices consists of certain elements that, when inserted in the card-in/card-out passage prevent users from retrieving their cards, which remain trapped until the thief fishes it out by means of such card-trapping device.

[0005] Currently available security devices cannot efficiently avoid this type of maneuvers or scams, or else are very complex and expensive.

**II - SUMMARY OF THE INVENTION**

[0006] This invention relates to an electronic security device based on an optoelectronic sensing barrier aligned transversely to the passage of transaction cards, and further relates to a card reader driver including such device. The device comprises an optoelectronic sensing barrier transversely aligned to a card-in/card-out passage, and an electronic circuit connected to such sensing barrier and comprising one or more emergency or alarm signal outputs responsive to intrusions through the sensing barrier.

DISCLOSURE OF INVENTION

[0007] It is an object of this invention to effectively prevent criminal maneuvers with ATM cards.

[0008] An advantage of this device is that it allows to sense the area adjacent to the card input slot connected to the card-in/card-out passage of cards in an automated teller machine to detect the presence of foreign means, such as the so-called "card-trapping devices".

[0009] A further advantage of this device is that is fully

electronic and lacks mechanical elements, which substantially minimize its preventive and corrective maintenance, thus increasing the MTBF, i.e. meantime between failure.

5 [0010] A further advantage of this device is that is capable of detecting the presence of false input slots attached to the external front panel of the original input slot, thus increasing protection against new fraud techniques.

10 [0011] A further objective of this invention is to replace mechanical means with an optoelectronic barrier consisting of a plurality of transmitter/receiver elements which -transversely aligned- propagate light rays across the card-in/card-out passage.

15 [0012] A further advantage is the flexibility to adapt to different variants, since the transmitter/receiver means can emit either infra red or other types of light radiation. In addition, the device is suitable to include a secondary optoelectronic barrier situated beneath the movable wall panel or guillotine to detect cards trapped in the card input channel.

20 [0013] A further advantage of the invention is that it can include different mechanical, optical, etc. sensors on the external front panel to detect the application of false sleeves.

25 [0014] A further advantage of this device is that it can be easily adapted to reader drivers, enabling operation connected to a conventional width sensor or guillotine sensor which are normally built in such reader drivers.

30 [0015] A further advantage is that the timers (analogue & digital timers with built-in microprocessors or any combinations thereof) of the electronic circuit or unit can in the presence of certain conditions send the ATM a signal to be redirected to the network indicating the presence of a card trap device installed therein. Further, it has a relay which is operated in case of a warning signal, thus enabling local action (beeper, lighting signaling or any other deterrent method).

**III- DESCRIPTION OF DRAWINGS**

40 [0016] To provide greater clarity and to facilitate understanding of the object of this invention several illustrations are included herein to describe the invention in one of its preferred embodiments, however, such descriptions and illustrations are by way of examples and no unnecessary limitations are to be implied therefrom.

50 Figure 1 is a longitudinal view of a card reader driver incorporating an exemplary embodiment of the present invention.

Figure 2 is a front view of the reader driver.

Figure 3 is a top view of the reader driver.

55 Figure 4 is a schematic diagram representative of the component parts of the present device and card driver.

Figure 5 is a schematic diagram representative of an exemplary embodiment of the electronic circuit.

Figure 6 is a schematic view representative of the

connection between the present device and the card reader means.

**[0017]** The same numbers, letters or combinations thereof are used as reference characters to designate same parts or related parts of the invention appearing in more than one view.

#### REFERENCE NUMERALS IN DRAWINGS

#### **[0018]**

- (1) Reader driver
- (2) External front panel
- (3) Card input opening or slot
- (4) Card-in/card-out passage
  - (4a) Primary passage area (4)
  - (4b) Intermediate area (between the input opening (3) and the internal operational area (6))
- (5) Movable wall panel (guillotine-type cutter)
- (6) Internal operational area
- (7) (primary or preceding) optoelectronic barrier
  - (7a) Transmitter supply unit (7)
- (8) Secondary or (beneath) optoelectronic barrier
  - (8a) Signal of (8)
- (9) Front sensors or detectors (for attached false sleeve slots)
  - (9a) Signal of (9)
- (10) Electronic circuit
- (11) Width sensor
  - (11a) Signal of (11)
- (12) Guillotine sensor
  - (12a) Signal of (12)
- (13) First combinational comparator
- (14) First timer
- (15) Second timer
- (16) Third timer
- (17) Second combinational comparator
- (18) Alarm-cycle generator
- (19) Power supply
  - (19a) Module connections
- (20) Card reader header
- (21) Guillotine switch signal

(21a) Ground of (21)

(22) Width switching signal

(22a) Ground of (22)

(23) Guillotine solenoid supply unit

(23a) Ground of (23)

(24) Device supply unit

(24a) Ground of (24)

(30) External Alarm

(31) Relay to (30)

#### **IV- DETAILED DESCRIPTION**

**[0019]** The present invention consists of an **electronic security device for automated teller machines** comprising an optoelectronic sensing machine (7) transversally aligned to a card-in/card-out passage (4), further comprising an electronic circuit (10) connected to such sensing barrier (7) and including one or more emergency or alarm signal outputs responsive to intrusions passing through the sensing barrier (7); the invention further relates to a **card reader driver** (1) including such device.

**[0020]** More specifically, the present electronic security device is applicable to an automated teller machine (**ATM**) for the detection of foreign instruments or bodies that can be inserted in the card-in/card-out transaction passage (4). Such passage (4) is arranged between an input opening (3) situated on the external front panel and an internal operational area (6) of the device. In the intermediate area of such passage (4b) a movable wall (5) having temporary closure can be provided to operate as a guillotine-type device.

**[0021]** The ATM card reader driver (1) comprises a card-in/card-out passage (4) extending between an input opening (3) situated on the external front panel and an internal operational area (6).

**[0022]** In an intermediate area (4b) situated between the input opening (3) and the internal operational area (6) there is a movable wall (5) which moves upwards and downwards like a guillotine type-cutter, temporarily blocking such input/output passage.

**[0023]** In the preceding area (4a) of the input/output passage (4) there is an optoelectronic sensing barrier (7) aligned transversely to such passage (4). This optoelectronic sensing barrier (7) comprises a plurality of light transmitter/receiver devices which, relative to the passage (4), are transversely aligned on both opposite sides thereof. Thus, the light rays emitted by these transmitter means propagate along the input/output passage (4) until reaching the receiver means.

**[0024]** In different embodiments of the invention, the light emitted can be light of the visible spectrum, ultravi-

olet light, infra red light, etc. Transmitters can be light emitting diodes, incandescent lamps, fluorescent lamps or other light-emitting source. Light receivers can be photo diodes, photo transistors, LDR, photo voltaic cells or other light-sensitive element.

**[0025]** Furthermore, the embodiments contemplate the inclusion of sensing means on the external front panel (9) of the card reader driver (1), capable of detecting the attachment of false external front panels carrying card-trapping elements.

**[0026]** In other embodiment of the invention the arrangement of a secondary optoelectronic barrier (8) is provided which is positioned intermediate the movable wall panel (5) and the internal operational area (6).

**[0027]** Furthermore, the present device comprises an electronic circuit (10) which processes the signals from the sensing barrier (7) and which is capable of generating alarm signals (18).

**[0028]** Such electronic circuit comprises a comparator stage, a timer stage and an alarm-cycle generator (18). Thus, in this exemplary embodiment of the invention the electronic circuit (10) comprises a first combinational comparator and second combinational comparator (13) (17), a first timer, a second timer and third timer (14) (15) (16) and one alarm-cycle generator (18).

#### OPERATION

**[0029]** When an object is inserted in the input opening (3) of the card reader driver (1), such object intercepts one or more light beams of the optoelectronic barrier (7) which operates as a scanner of such input opening (3).

**[0030]** If the cut-off of light is total (the entire light beams are intercepted), it may be a valid card or a card-trapping device the width of which covers the full input opening area (3).

**[0031]** A valid card does not remain in this position for more than a few seconds since the card reader driver (1) pulls the card to read it inside (6) (the same occurs if the user forgets to take his/her card from the card reader driver (1). If the cut-off continues for more than the preset time, the object is a card trap device and an alarm cycle is triggered.

**[0032]** If the cut-off of the optoelectronic barrier (7) is partial, the object cannot be a card; if the same remains inserted for an additional set time it is a card-trapping device and an the alarm cycle is triggered (18).

**[0033]** The width sensor signal (11) is used to certify the presence of an element having a similar width range to a real card.

**[0034]** The open signal of the movable wall (the guillotine is open), together with the partial cut-off of the barrier (7) trigger the alarm cycle (18).

**[0035]** The open signal of the movable wall, together with the total cut-off of the barrier (7) generate an additional interval cycle (waiting for an additional time frame) and after the interval cycle lapses the alarm process restarts.

**[0036]** If the movable wall (5) remains open, the cut-off of the barrier beams (7) is total and the secondary barrier (8) beneath the movable wall (5) is disrupted, indicating the presence of a card trapped in the input slot (4) of the card reader (1), and generating no alarm signal.

**[0037]** The system can be used as a trapping-device detector in deposit boxes and cash dispensers.

**[0038]** The primary optoelectronic barrier (7) propagates the signals of infra red beams to the electronic circuit (10).

The mechanical or primary sensing devices (9) refract their respective signals (9a) to the electronic circuit (10).

**[0039]** The width sensor (11) propagates the signal (11a) to the electronic circuit (10).

**[0040]** The guillotine sensor (12) of the movable wall or guillotine-type device (5) propagates the signal (12a) to the electronic circuit (10).

**[0041]** The secondary optical barrier (8) beneath the movable wall (5) propagates the signal (8a) to the electronic circuit (10).

**[0042]** The electronic circuit (10) sends the alarm signal to the ATM machine.

**[0043]** The electronic circuit (10) activates the relay (31) in case of detecting a card trapping device (external warning).

**[0044]** The function of the primary barrier (7) is to detect either total or partial disruption or alteration of one or more of its beams (including that of transparent objects in the primary area (4a) of the passage (4), in the adjacent sides of the input opening (3) of the front panel (2).

**[0045]** The function of the width sensor (11) is to detect the entry or presence within the passage (4) of an object having a similar width to a valid card. This sensing device is an electromechanical sensor (e.g. micro switch) which is operated by the side pressure applied by the card in the passage (4).

**[0046]** The function of the guillotine sensor (12) is to detect the position of the movable wall or guillotine-type device (5) [close is normal mode, open is alert mode]. This sensing device is an electromechanical sensor [e.g. micro switch] which is operated according to the position of the movable wall (5).

**[0047]** The secondary barrier (8) operates as a trapped/stuck card sensor when it detects the presence of a trapped card [due to deformation or other cause] inside the input passage (4)

**[0048]** The function of the front or primary sensors or detectors (9) is to detect the presence of a "false" sleeve with a card trap that a scammer intentionally attaches over the ATM slot front (2) of the card reader driver (1). These sensing devices can be one or more mechanical sensors and are installed on the external front (2) panel; and are operated by the pressure applied over the sleeve attached to the front panel (2) of the card reader (1). In a further variant one or more light sensors can be installed in the front panel (2) of the card reader (1). These receivers sense the light variation [darkening on the original front (2)], which occurs when a false front or sleeve is

installed.

**[0049]** This device can be added to existing card reader drivers (1) or else, new card reader units (1) can be manufactured with this new device.

### Claims

1. an electronic security device for automated teller machines, which is applicable to an automated transaction machine for the detection of foreign instruments or bodies along the card-in/card-out transaction passage -with an intermediate portion that can include or not a movable wall having temporary closure that operates as a guillotine-type device-, with such passage extending from the input opening on the external front panel to an internal operational area in such automated teller machine, comprising:

(a) Inside the card-in/card-out passage, at least one optoelectronic sensing barrier transversally aligned to such passage; and

(b) At least one electronic circuit connected to such optoelectronic sensing barrier and with at least one emergency or alarm signaling output.

2. the electronic security device for automated teller machines according to claim 1, wherein the optoelectronic sensing barrier is situated in the front area -adjacent to the input opening - of the card-in/card-out passage.

3. the electronic security device for automated teller machines according to claim 1, comprising a secondary optoelectronic sensing barrier situated between the movable wall and the internal operational area.

4. the electronic security device for automated teller machines according to claims 1, 2 and 3, wherein the optoelectronic sensing barrier comprises a plurality of light transmitter/receiver means, which are -relative to the passage- transversely aligned on both opposite sides of such passage, so that the light passes through the entire width thereof.

5. the electronic security device for automated teller machines according to claim 4, wherein the light transmitter/receiver means are infra red light.

6. the electronic security device for automated teller machines according to claim 4, wherein the light transmitter/receiver means are UV light.

7. the electronic security device for automated teller machines according to claim 4, wherein the light transmitter/receiver means are visible spectrum light.

8. the electronic security device for automated teller machines according to claim 1, comprising sensing devices on the external front panel.

9. the electronic security device for automated teller machines according to claim 1, wherein the electronic circuit comprises at least a comparator stage and at least a timer stage.

10. the electronic security device for automated teller machines according to claims 1 and 9, wherein the electronic circuit comprises a first comparator and a second comparator, a first, second and third timer and one alarm cycle generator.

11. the electronic security device for automated teller machines including the aforementioned claims, comprising a frame wherein the transversal optoelectronic sensing barriers and the electronic circuit are mounted.

### Amended claims in accordance with Rule 86(2) EPC.

1. An electronic security device to avoid card fraudulent actions in a automated teller machine (ATM), being said device able to detect foreign instruments or bodies along a card-in/card-out transaction passage (4), said passage (4) including a primary area (4a) and a intermediate area (4b), this latter can include a movable wall (5) of temporary closure that operates as a guillotine-type device-, such passage (4) extending from a card input opening (3) on the external front panel (2) of said device to an internal operational area (6) inside said automated teller machine, said device further comprising an optoelectronic sensing barrier (7) located in said primary area (4a) and before said movable wall (5), transversely aligned to said passage (4); consisting of light transmitter/receiver means that occupy the entire width of said passage (4), wherein said transmitter means emit(s) light across said passage (4) until reaching said receiver means.

2. The electronic security device according to claim 1, wherein said primary area (4a) is located between said card input opening (3) and said intermediate area (4b).

3. The electronic security device according to claim 1, wherein said intermediate area (4b) is located between said primary area (4a) and said internal operational area (6).

4. The electronic security device according to claim 1, wherein said transmitter means emit(s) light.

5. The electronic security device according to claim

4, wherein said light is transmitted from said transmitter means across said passage (4) until reaching said receiver means.

**6.** The electronic security device according to claim 4, wherein said light consists of visible spectrum light, ultraviolet light, infrared light or the like. 5

**7.** The electronic security device according to claim 1, wherein said transmitter means can be light emitting diodes, incandescent lamps, fluorescent lamps, or any other light emitting source, and said receiver means can be photo diodes, photo transistors, photo voltaic cells or any other light sensitive element. 10

**8.** The electronic security device according to claim 1, wherein said optoelectronic sensing barrier (7) is associated to an electronic circuit (10) which is in turn connected to at least one emergency or alarm signaling output. 15 20

**9.** A card reader driver used in a automated teller machine (ATM) that comprises the electronic security device of claim 1. 25

25

30

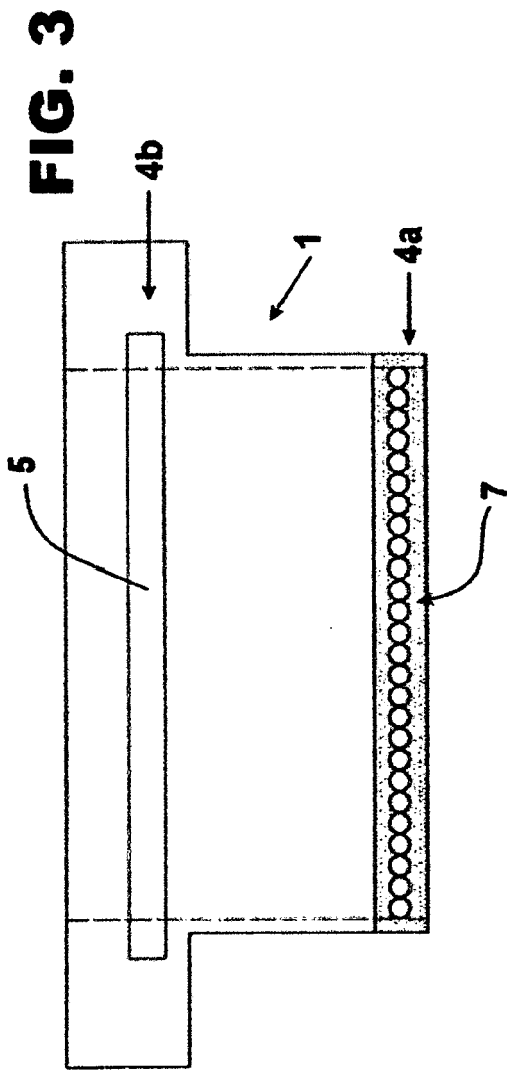
35

40

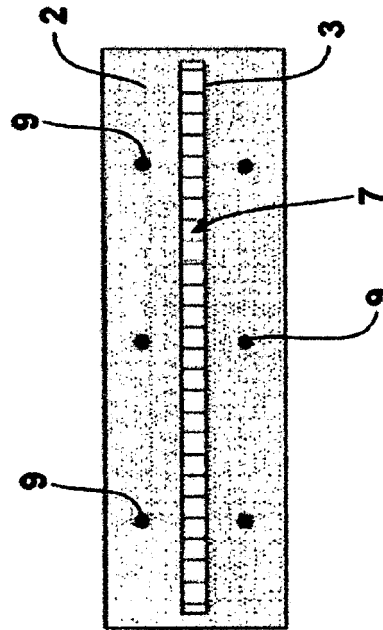
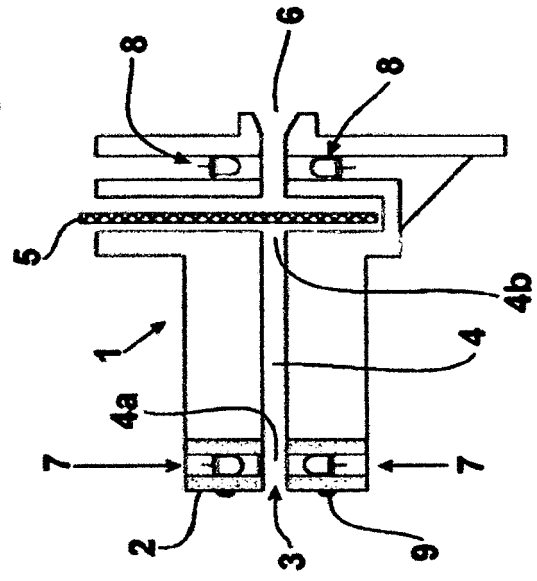
45

50

55

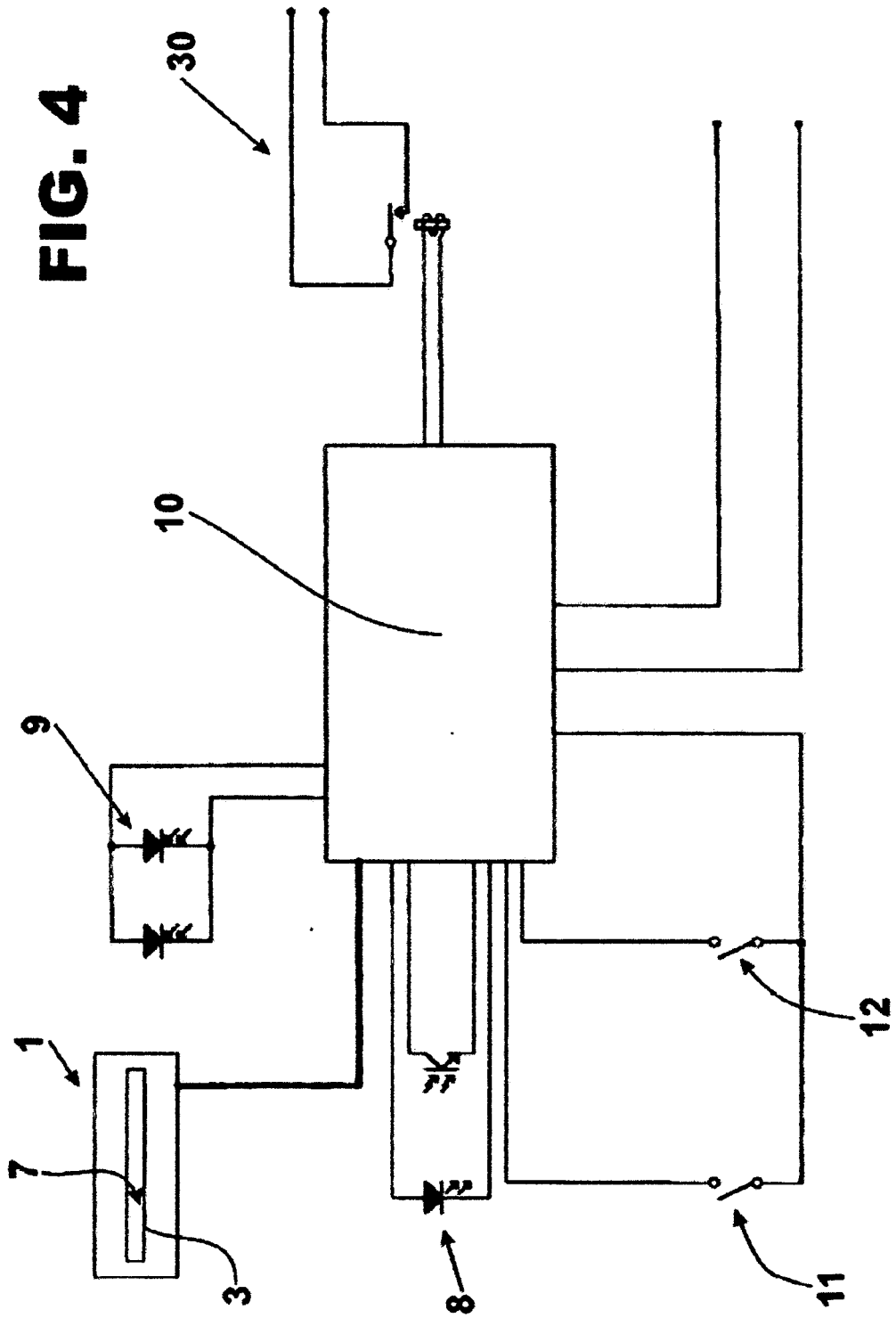


**FIG. 1**

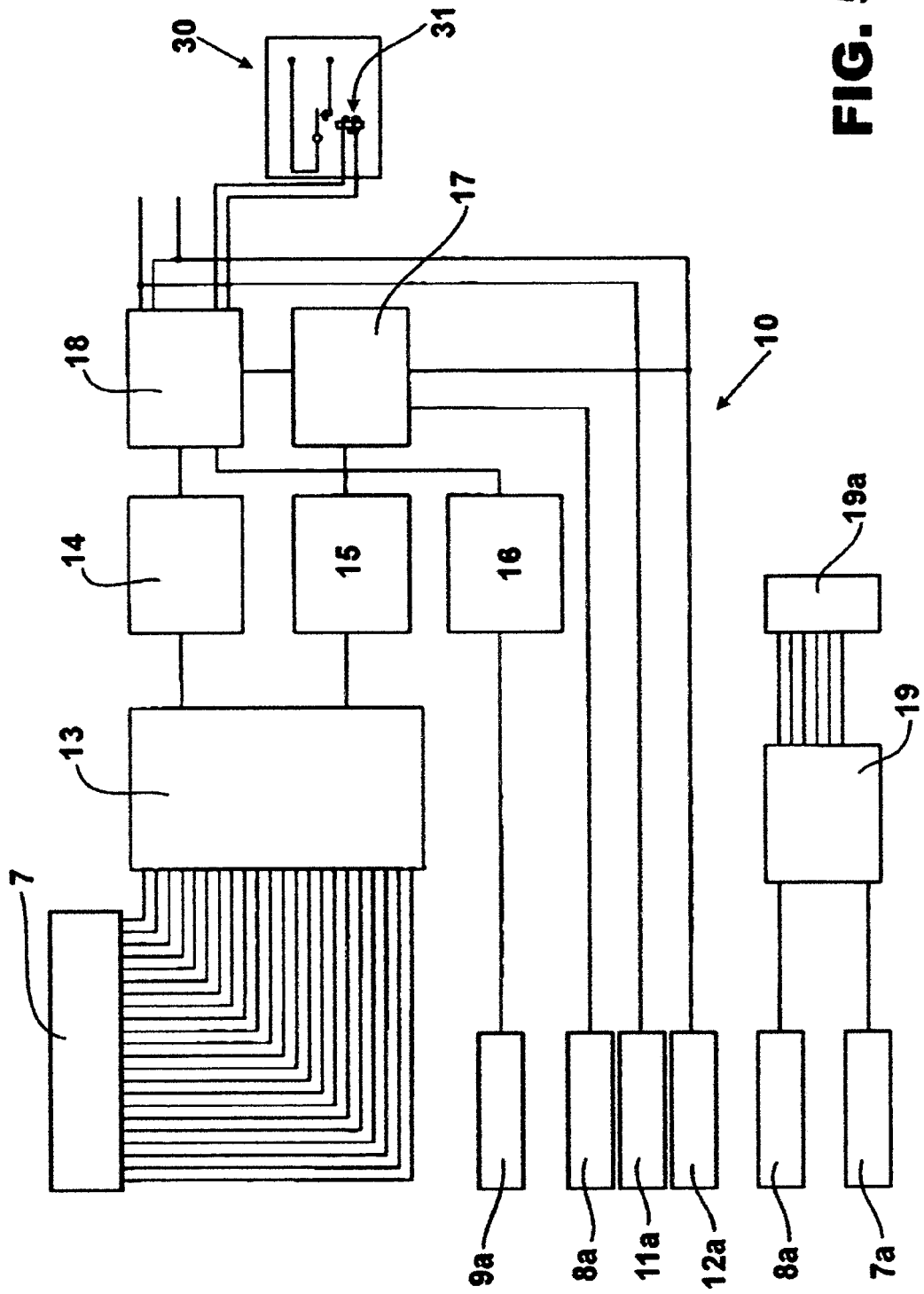


**FIG. 2**

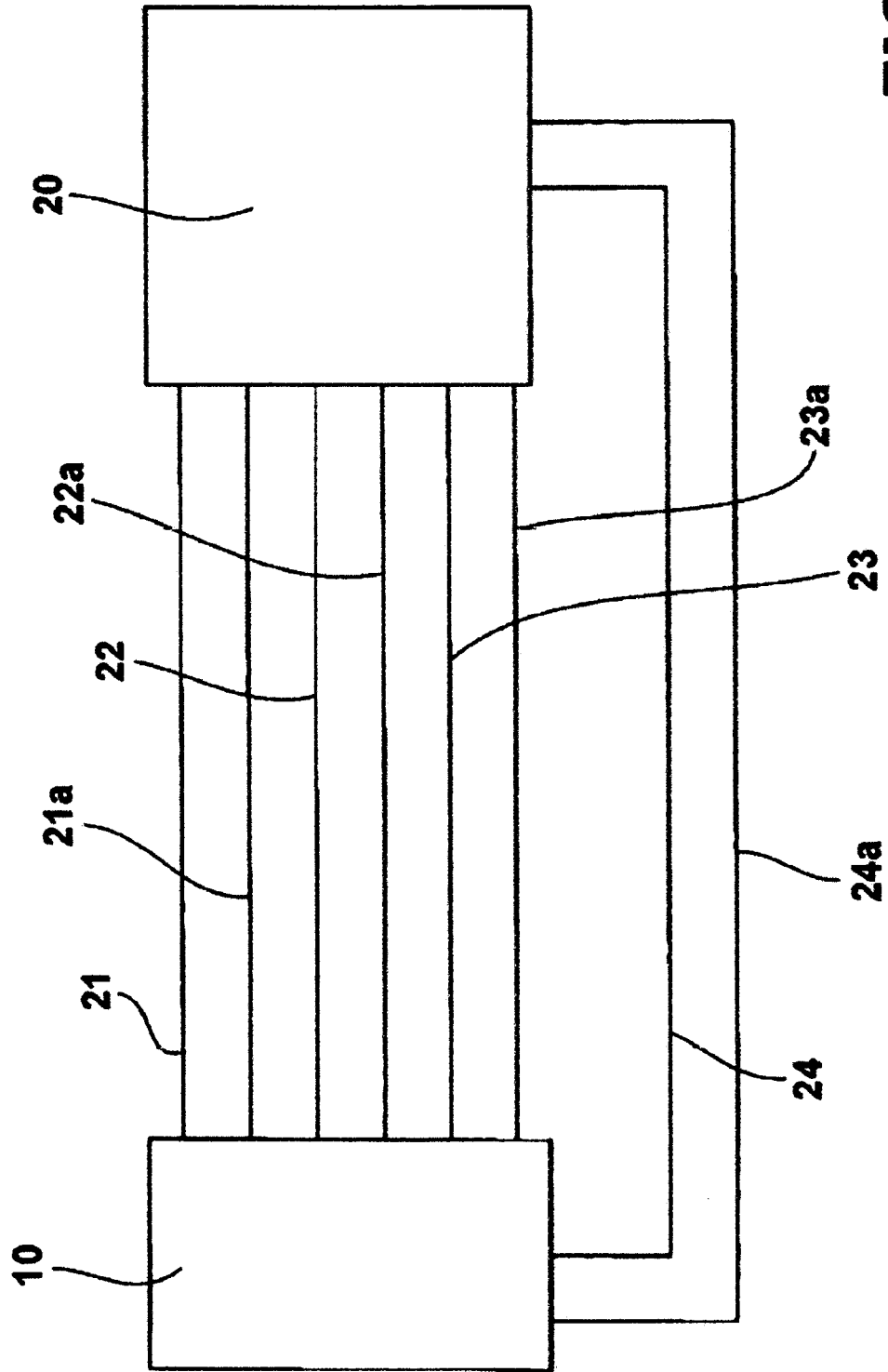
**FIG. 4**







**FIG. 5**



**FIG. 6**



DOCUMENTS CONSIDERED TO BE RELEVANT			
Category	Citation of document with indication, where appropriate, of relevant passages	Relevant to claim	CLASSIFICATION OF THE APPLICATION (Int.Cl.7)
X	US 4 514 623 A (BAUS ET AL) 30 April 1985 (1985-04-30) * column 2, line 5 - column 4, line 14 * * figures *	1-11	G07F19/00
Y	----- EP 1 071 050 A (NCR INTERNATIONAL, INC) 24 January 2001 (2001-01-24) * abstract * * column 1, paragraph 3 - column 8, paragraph 24 * * figures *	1-11	
Y	----- WO 2004/081740 A (DIEBOLD INCORPORATED; SCARAFI, PIETRO; GHIRINGHELLI, PIERO; CERIONI,) 23 September 2004 (2004-09-23) * page 23, line 24 - page 35, line 20 * * figures 14-17 *	1-11	
A	----- GB 2 351 590 A (* NCR INTERNATIONAL INC) 3 January 2001 (2001-01-03) * abstract * * page 5 - page 7 * * figure 2 *	8	
A	----- EP 1 394 728 A (OMRON CORPORATION) 3 March 2004 (2004-03-03) * column 7, paragraph 34 - column 17, paragraph 97 * * figures *	1-11	
The present search report has been drawn up for all claims			
Place of search The Hague		Date of completion of the search 9 May 2005	Examiner Rachkov, V
<p>CATEGORY OF CITED DOCUMENTS</p> <p>X : particularly relevant if taken alone                      Y : particularly relevant if combined with another document of the same category                      A : technological background                      O : non-written disclosure                      P : intermediate document</p> <p>T : theory or principle underlying the invention                      E : earlier patent document, but published on, or after the filing date                      D : document cited in the application                      L : document cited for other reasons                      .....                      &amp; : member of the same patent family, corresponding document</p>			

3  
EPC FORM 1503 03.82 (P04/C01)

**ANNEX TO THE EUROPEAN SEARCH REPORT  
ON EUROPEAN PATENT APPLICATION NO.**

EP 04 38 0296

This annex lists the patent family members relating to the patent documents cited in the above-mentioned European search report. The members are as contained in the European Patent Office EDP file on  
The European Patent Office is in no way liable for these particulars which are merely given for the purpose of information.

09-05-2005

Patent document cited in search report		Publication date	Patent family member(s)	Publication date
US 4514623	A	30-04-1985	NONE	
-----				
EP 1071050	A	24-01-2001	GB 2352552 A	31-01-2001
			BR 0002942 A	03-04-2001
			CN 1282046 A	31-01-2001
			EP 1071050 A1	24-01-2001
			US 6491216 B1	10-12-2002
-----				
WO 2004081740	A	23-09-2004	US 2004129772 A1	08-07-2004
			US 2005073584 A1	07-04-2005
			US 2004178258 A1	16-09-2004
			US 2004178259 A1	16-09-2004
			US 2004178260 A1	16-09-2004
			WO 2004081740 A2	23-09-2004
-----				
GB 2351590	A	03-01-2001	US 6390367 B1	21-05-2002
-----				
EP 1394728	A	03-03-2004	JP 2004070476 A	04-03-2004
			CN 1479248 A	03-03-2004
			EP 1394728 A1	03-03-2004
			US 2004035929 A1	26-02-2004
-----				