

(12) UK Patent Application (19) GB (11) 2566168 (13) A

(43) Date of Reproduction by UK Office 06.03.2019

(21) Application No: 1817210.6

(22) Date of Filing: 13.07.2017

Date Lodged: 23.10.2018

(30) Priority Data:  
(31) 62362283 (32) 14.07.2016 (33) US

(86) International Application Data:  
PCT/GB2017/052064 En 13.07.2017

(87) International Publication Data:  
WO2018/011586 En 18.01.2018

(51) INT CL:  
G02B 1/04 (2006.01) B29D 11/00 (2006.01)  
G02C 7/04 (2006.01)

(56) Documents Cited:  
GB 2563182 A EP 2483737 A2  
WO 2013/186573 A1 WO 2012/016152 A1  
US 20130162942 A1 US 20030052424 A1

(58) Field of Search:  
INT CL B29D, G02B, G02C  
Other: EPO-Internal, WPI Data

(71) Applicant(s):  
CooperVision International Holding Company, LP  
(Incorporated in the United Kingdom)  
Edghill House, Wildey Business Park, Suite 2,  
St. Michael, Barbados

(72) Inventor(s):  
Paul Richardson  
Nancy J Keir  
Xinfeng Shi  
James Mun

(74) Agent and/or Address for Service:  
Abel & Imray  
Westpoint Building, James Street West, Bath,  
BA1 2DA, United Kingdom

(54) Title of the Invention: **Method of manufacturing silicone hydrogel contact lenses having reduced rates of evaporation**  
Abstract Title: **Method of manufacturing silicone hydrogel contact lenses having reduced rates of evaporation**

(57) A wettable silicone hydrogel contact lens having a low ionoflux and low evaporation is manufactured by curing a silicone hydrogel polymerizable composition in a contact lens mold comprising front and back lens-forming surfaces, where one of the lens-forming surfaces has a higher polarity than the other lens-forming surface.

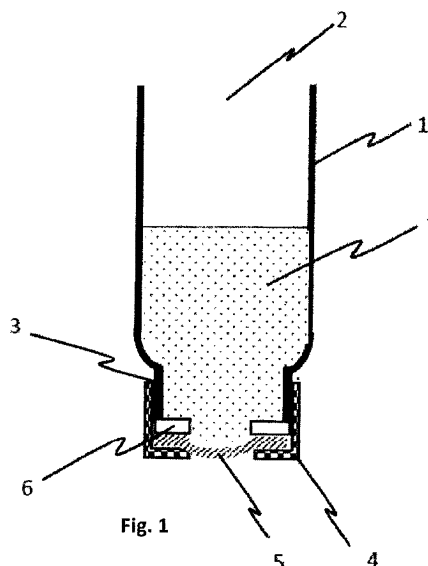

Fig. 1

GB 2566168 A