



HU000027971T2

(19) **HU**(11) Lajstromszám: **E 027 971**(13) **T2****MAGYARORSZÁG**
Szellemi Tulajdon Nemzeti Hivatala**EURÓPAI SZABADALOM**
SZÖVEGÉNEK FORDÍTÁSA(21) Magyar ügyszám: **E 12 819124**(51) Int. Cl.: **B25B 29/02** (2006.01)(22) A bejelentés napja: **2012. 12. 18.**

(86) A nemzetközi (PCT) bejelentési szám:

(96) Az európai bejelentés bejelentési száma:
EP 20120819124**PCT/GB 12/053167**(97) Az európai bejelentés közzétételi adatai:
EP 2794192 A1 **2013. 06. 27.**

(87) A nemzetközi közzétételi szám:

WO 13093443(97) Az európai szabadalom megadásának meghirdetési adatai:
EP 2794192 B1 **2016. 03. 16.**

(30) Elsőbbségi adatok: 201121976 2011. 12. 20. GB	(73) Jogosult(ak): Tenscon limited, Wolverhampton West Midlands WV4 5 (GB)
(72) Feltaláló(k): CENEY, Stan, Wolverhampton West Midlands WV2 4PF (GB)	(74) Képviselő: ADVOPATENT Szabadalmi és Védjegy Iroda, Budapest

(54)

Feszítőszerkezet

Az európai szabadalom ellen, megadásának az Európai Szabadalmi Közlönyben való meghirdetésétől számított kilenc hónapon belül, felszólalást lehet benyújtani az Európai Szabadalmi Hivatalnál. (Európai Szabadalmi Egyezmény 99. cikk(1))

A fordítást a szabadalmas az 1995. évi XXXIII. törvény 84/H. §-a szerint nyújtotta be. A fordítás tartalmi helyességét a Szellemi Tulajdon Nemzeti Hivatala nem vizsgálta.



(11) **EP 2 794 192 B1**

(12) **EUROPEAN PATENT SPECIFICATION**

(45) Date of publication and mention of the grant of the patent:
16.03.2016 Bulletin 2016/11

(21) Application number: **12819124.4**

(22) Date of filing: **18.12.2012**

(51) Int Cl.:
B25B 29/02 (2006.01)

(86) International application number:
PCT/GB2012/053167

(87) International publication number:
WO 2013/093443 (27.06.2013 Gazette 2013/26)

(54) **A TENSIONING APPARATUS**

SPANNVORRICHTUNG

APPAREIL DE MISE EN TENSION

(84) Designated Contracting States:
AL AT BE BG CH CY CZ DE DK EE ES FI FR GB GR HR HU IE IS IT LI LT LU LV MC MK MT NL NO PL PT RO RS SE SI SK SM TR

(30) Priority: **20.12.2011 GB 201121976**

(43) Date of publication of application:
29.10.2014 Bulletin 2014/44

(73) Proprietor: **Tenscon limited**
Church Hill, Penn,
Wolverhampton
West Midlands WV4 5PF (GB)

(72) Inventor: **CENEY, Stan**
Wolverhampton
West Midlands WV2 4PF (GB)

(74) Representative: **Thurston, Mark**
Barker Brettell LLP
100 Hagley Road
Edgbaston
Birmingham, West Midlands B16 8QQ (GB)

(56) References cited:
DE-A1- 2 238 974 DE-U1-202008 012 922
US-A- 4 391 431 US-A- 5 075 950

EP 2 794 192 B1

Note: Within nine months of the publication of the mention of the grant of the European patent in the European Patent Bulletin, any person may give notice to the European Patent Office of opposition to that patent, in accordance with the Implementing Regulations. Notice of opposition shall not be deemed to have been filed until the opposition fee has been paid. (Art. 99(1) European Patent Convention).

Description

[0001] The present invention relates to a tensioning apparatus for tensioning studs and bolts in bolted joints, as known for example from DE-20-2008-012,922.

[0002] It is commonly known that if bolted joints are not correctly tensioned or secured together with the correct compressive force or load, then those joints are likely to eventually fail or otherwise experience some form of mechanical fatigue. Accordingly, there are therefore numerous mechanical problems that may potentially result if a bolted joint is not correctly tensioned.

[0003] Many bolted joints are fastened together by way of a stud, bolt, threaded rod or shaft having two conventional nuts at either end, which are then tightened together to attain a desired preload tension in the joint. However, one of the major problems associated with traditional stud tightening techniques is as the diameter of the stud increases, the amount of torque required to tighten it increases exponentially as the third power of the diameter. Consequently, the largest size stud or bolt that may typically be tightened by hand is around 3 cm.

[0004] To address this problem, the prior art provides several ways of tensioning studs or bolts without requiring excessive amounts of torque to tighten the stud or bolt. One popular device is what is known as a multi-jackbolt tensioner¹, which is a direct replacement for conventional nuts. The device can be simply threaded onto a new or existing stud, bolt, rod or shaft and works by using multiple jackbolts or cap screws that are threaded through the body of the nut or bolt head. Tensioning of the bolted joint is accomplished by applying torque to each of the jackbolts, which are small enough to be tightened by simple hand tools. The jackbolts press against a hardened washer, which transfers the preload evenly into the stud or bolt, and consequently, onto the bolted joint.

[0005] In this way, collective loads of up to around 100 MN and greater may be achieved by using only hand tools, such as a torque wrench or a pneumatic tool. Therefore, it is evident that the use of multi-jackbolt tensioners provides many benefits over other tightening techniques, not least in that the bolted joint is tightened in pure tension (i.e. no torsional strain), with only simple tools being required for tightening; while they can also be installed in confined spaces (as they are a direct replacement for a nut) without significant downtime.

[0006] However, although multi-jackbolt tensioners are reliable and safe devices for compressing a bolted joint to a desired load, they do have the drawback that they are costly components (due to having multiple parts and requiring accurate machining during fabrication) with one tensioner being permanently required for each stud or bolt to be tensioned. Therefore, if a mechanical structure comprises a large number of bolted joints, the cost to tighten each of these may be prohibitive as a tensioner cannot be reused for subsequent studs or bolts without removing it from the bolted joint.

[0007] Hence, it is an object of the present invention to address some, if not all, of the above problems in the art, by providing a reusable tensioning apparatus and kit for tensioning multiple bolted joints without the need to have a permanent tensioner for each joint.

[0008] According to the present invention there is provided an apparatus for tensioning a stud in a bolted joint to a desired preload having the features of claim 1.

[0009] The provision of a tensioning apparatus comprising at least some components that are removable after a desired preload for a stud is achieved is found to be particularly advantageous, as only a single tensioner (e.g. multi-jackbolt tensioner etc.) is required to tension multiple studs. By contrast, conventional techniques require a permanent tensioner for each and every stud, which must remain in place even after the stud is tensioned to the desired preload.

[0010] Therefore, the present invention allows reuse of the same tensioner, which avoids the costs of having to acquire multiple tensioners.

[0011] It is to be appreciated that the use of the term "stud" herein is intended to cover all kinds of studs, bolts, threaded rods and shafts, and indeed the apparatus of the present invention may be used with all kinds of fastening devices that are typically used to compress bolted joints to a required tension and where a tensioner of a multi-jackbolt type, for instance, is conventionally used to apply tension to the joint.

[0012] By "bolted joint" we mean any mechanical joint, coupling or connection between two or more components or mechanical assemblies that may be fastened or compressed together without limitation.

[0013] In particularly preferred embodiments, the locking means may be a threaded nut. The nut is preferably threaded so as to reciprocally engage the threading of the stud. In this way, the locking means may then be simply screwed onto the stud.

[0014] The nut may have a circular or hexagonal cross-section. However, any suitable cross-section may be used.

[0015] Preferably, in exemplary embodiments, the nut has a circular cross-section and comprises at least one radial bore hole through the body of the nut, and most preferably, comprises a plurality of radial bore holes. By "radial bore hole" we mean a preferably circular channel through the body of the nut, such that the channel has an axis that is approximately orthogonal to the longitudinal axis of the nut. The bore hole may extend fully through the body of the nut (i.e. open at both ends) or else extend only partially through the body (i.e. closed at one end - the end closest to the interior surface of the nut).

[0016] The function of the bore holes is to receive the removable actuator, in that the actuator may be releasably engaged with the bore hole to enable the nut to be turned (i.e. screwed) on the stud so that the nut can be tightened. In this way, the locking means may be locked when a desired preload is achieved in the stud, as will be discussed in more detail below.

[0017] In preferred embodiments, the removable bridge member is substantially cylindrical (e.g. tubular) in form and preferably comprises an open end and a closed end. The circumferential 'lip' of the open end preferably acts as a 'surface' for engaging the planar surface of the bolted joint to be tensioned; while the closed end preferably includes an open bore (e.g. circular aperture) for receiving the stud. In other words, the bridge member may be placed over the stud so that the stud passes through and along the longitudinal axis of the bridge member.

[0018] When the bridge member is placed over the stud, it then at least partially encloses (or covers) the locking means. In preferred embodiments, the bridge member comprises at least one aperture or window through which the actuator may pass to releasably engage with the locking means. The aperture is preferably located in a side wall of the bridge member and will typically take the form of a cut-out or cut-away portion of the bridge member. Indeed, in particularly preferred embodiments, the aperture may be a substantially 'U-shaped' cut-out having an 'open edge' that extends to the circumferential lip of the open end of the bridge member.

[0019] However, it is to be appreciated that any shape or form of aperture may be used, provided it allows the actuator access to the locking means. Moreover, two or more apertures may be used to enable greater access to the locking means depending on the particular application and implementation of the present apparatus.

[0020] In particularly preferred embodiments, the removable actuator comprises an elongate rod adapted to engage with at least one of the radial bore holes. The elongate rod is preferably fabricated from hardened steel and is most preferably a conventional "tommy bar". The actuator may therefore be inserted through the aperture of the bridge member to engage with a bore hole, enabling the locking means (e.g. nut) to be turned. The actuator may then be removed and (re-)inserted into the next bore hole which has been rotated into the aperture. In this way, the nut may be turned and tightened by repeated application of the tommy bar to the nut.

[0021] The use of a tommy bar and circular nut is especially advantageous, as it allows the nut and bridge member to be respectively sized so that only a small internal (circumferential) gap exists between them. As a result, the 'foot print' (i.e. diameter) of the bridge member can be kept relatively small, which allows the present apparatus to be used in confined spaces or difficult to install locations. By contrast, if the nut were a conventional hexagonal nut, with the actuator being a wrench or spanner, the spacing between the nut and the bridge member would need to be considerably larger to enable the wrench to engage with the nut through the aperture. Although such an arrangement is not excluded by the present invention, this is not preferred. But it is possible that such an arrangement could be used in some applications and/or implementations.

[0022] The removable tensioning means preferably

comprises a jacking nut or a multi-jackbolt tensioner consisting of a plurality of jackbolts or cap screws. Indeed, in exemplary embodiments, the tensioner is ideally a nut-type multi-jackbolt tensioner having a pitch circle diameter of cap screws as known in the prior art.

[0023] The use of a multi-jackbolt tensioner is beneficial as it allows the many advantages of this type of tensioner to be utilised in the present application. Therefore, the stud may be tensioned to relatively large preload tensions by the application of only a relatively low torque to each of the cap screws. As a result, only simple hand tools or pneumatic devices need be used to load the bolted joint to the required tension. Moreover, as multi-jackbolt tensioners tighten the stud in pure tension there is no torsional strain.

[0024] The apparatus may further comprise a washer removably disposed between the tensioning means and the bridge member, such that the washer abuts the closed end of the bridge member. The washer is preferably made from hardened steel and serves to prevent damage to the closed end surface of the bridge member when the cap screws are tightened in the tensioner.

[0025] In use, the present apparatus tensions the stud to a desired preload by applying torque to each of the cap screws. The bridge member preferably sits atop the bolted joint and covers the locking means which have been engaged with the stud (e.g. the nut has been threaded onto the stud) and tightened against the surface of the bolted joint. The hardened washer preferably sits between the bridge member and the tensioning means (e.g. multi-jackbolt tensioner), which is also threaded onto the stud and rests against the washer on top of the bridge member.

[0026] When the stud is placed under load, it is found that it elastically extends or stretches according to Hooke's Law within its elastic limit (i.e. it undergoes elastic deformation along its length). The desired preload in the stud can be divided between the number of cap screws in the tensioner, as the individual loads on the cap screws combine to form the total load on the stud. By knowing the individual load required for each cap screw, a torque setting may be derived from established tables of load values, whereupon a simple hand tool (e.g. torque wrench) may be used to apply the required torque to each of the cap screws.

[0027] To ensure reliable tensioning of the bolted joint, the cap screws are preferably tightened in a careful sequence which avoids any non-symmetric loading of the cap screws. Therefore, a 'star' sequence for tightening the cap screws is preferably adopted, in that the cap screws are tightened in an order that preferably resembles the points on a star image, for example, diametrically opposite cap screws are tightened one after another so that symmetric loading of the jointed is achieved.

[0028] After initial loading, it is found that since the stud has extended, the nut no longer abuts against the surface of the bolted joint. Indeed, in practice an air gap actually forms between the nut and the surface of the bolted joint,

as a result of the tension in the stud. The actuator may then be re-inserted into the nut to preferably further tighten the nut to eliminate the air gap and enable the nut to bed down against the surface of the bolted joint. Additional tightening of the cap screws may then be performed, with the above procedure being repeated as often as necessary until the desired preload is achieved in the stud.

[0029] Once the preload is attained, the cap screws may then be relaxed as the tension in the stud (due to the action of the locking means) maintains compression or loading of the bolted joint. The tensioner, bridge member and actuator may then all be removed from the bolted joint, leaving the locking means in place to keep the joint together.

[0030] As a result, the removable components may then be advantageously re-used to tighten a further bolted joint, without the need for another tensioner. The only component that is not re-used is the locking means, but this is not as elaborate (or as expensive) to replace as another tensioner. Of course, the locking means may be subsequently re-used if it no longer becomes necessary to maintain the bolted joint under compression.

[0031] The use of the locking means not only saves costs but also permits easy maintenance of the bolted joint, as if it becomes necessary to release the compression of the joint only one component need be relaxed (i.e. untightened), as opposed to the multiple cap screws of conventional tensioners - which are themselves very quick to release. Hence, the present invention provides significant advantages over the prior art and can minimise downtime for maintenance and repair etc.

[0032] It is to be appreciated that none of the aspects or embodiments described in relation to the present invention are mutually exclusive, and therefore the features and functionality of one aspect and/or embodiment may be used interchangeably or additionally with the features and functionality of any other embodiment without limitation.

[0033] Embodiments of the present invention will now be described in detail by way of example and with reference to the accompanying drawings in which:

Figure 1 - shows a side cross-sectional view of a tensioning apparatus according to a particularly preferred embodiment of the present invention;

Figure 2 - shows a plan view of an example tensioner as used in the embodiment of Figure 1;

Figure 3 - shows a top cross-sectional view of part of the apparatus of Figure 1;

Figure 4 - shows a side cross-sectional view of the non-removable parts of the tensioning apparatus of Figure 1 after the stud has been tensioned to the desired preload;

[0034] Referring to Figure 1, there is shown a particularly preferred embodiment of a tensioning apparatus 10 according to the present invention. It is to be understood that the apparatus as shown in Figure 1 is not drawn to scale and therefore the figure is intended for illustrative purposes only, but this could represent any example bolted joint.

[0035] The tensioning apparatus 10 comprises a locking means 12 adapted for engagement with a stud 14, a removable bridge member 16 arranged to enclose or cover the locking means 12 and a removable actuator 18 operable to actuate the locking means 12 through the bridge member 16.

[0036] In addition, the tensioning apparatus 10 also comprises a removable tensioning means 20, which in this example is a nut-type multi-jackbolt tensioner having a pitch circle diameter of cap screws 22 (although only two cap screws are shown in cross-section in Figure 1).

[0037] As shown in Figure 1, the tensioning apparatus 10 is deployed in use against an example bolted joint 24 having respective abutting flanges 24a and 24b. The stud 14 passes through the flanges 24a, 24b and terminates in a conventional nut 26. The bolted joint 24 could be any mechanical joint, coupling or mechanical assembly that is intended to be compressed to a desired load or tension.

[0038] It is to be appreciated, however, that although Figure 1 shows a stud 14 and nut 26, this could alternatively be any form of mechanical fastener, such as a bolt, headed fastener or cap screw etc.

[0039] In the example shown, the locking means 12 is a threaded nut, which reciprocally engages the threading of the stud 14. In this way, the nut 12 may be simply screwed onto the stud 14 until it engages the surface of flange 24a.

[0040] The nut 12 has a circular cross-section and comprises a plurality of radial bore holes 12a through the body of the nut (as best shown in Figure 3). Any number of bore holes may be used, but in the example discussed herein the nut 12 has eight bore holes 12a.

[0041] Each bore hole 12 defines a circular channel through the body of the nut 12, such that the channel has an axis that is approximately orthogonal to the longitudinal axis of the nut. Each bore hole 12a extends fully through the body of the nut (as shown in Figures 1 & 3), but could alternatively extend only partially through the body (i.e. closed at one end - the end closest to the interior surface of the nut).

[0042] The function of the bore holes 12a is to receive the removable actuator 18, in that the actuator 18 may be releasably engaged with a bore hole 12a (as shown in Figures 1 & 3) to enable the nut 12 to be turned (i.e. screwed) on the stud 14 so that the nut can be tightened. In this way, the nut 12 may be locked (i.e. fully tightened) when a desired preload is achieved in the stud 14, as will be discussed in more detail below.

[0043] The removable bridge member 16 is cylindrical (e.g. tubular) in form and comprises an open end 16a and a closed end 16b. The circumferential 'lip' of the open

end 16a acts as a 'surface' for engaging the surface of the flange 24a; while the closed end 16b includes an open bore (e.g. circular aperture) for receiving the stud 14 (as shown in Figure 1). In other words, the bridge member 16 is placed over the stud 14 so that the stud passes through and along the longitudinal axis of the bridge member.

[0044] Referring to Figure 1, when the bridge member 16 is placed over the stud 14, it covers the nut 12. However, the bridge member 16 comprises an aperture or window 17 through which the actuator 18 can pass to releasably engage with the nut 12. The aperture 17 is located in the side wall of the bridge member 16 and takes the form of a cut-out portion of the bridge member.

[0045] In the example shown, the actuator 18 is in the form of an elongate rod, such as a "tommy bar", fabricated from hardened steel. The tommy bar 18 may therefore be inserted through the aperture 17 of the bridge member 16 to engage with a bore hole 12a (as shown in Figures 1 and 3), enabling the nut 12 to be turned. The tommy bar 18 may then be removed and (re-)inserted into the next bore hole 12a which has been rotated into the aperture 17. In this way, the nut 12 may be turned and tightened by repeated application of the tommy bar 18 to the nut.

[0046] Referring again to Figure 1, the tensioning apparatus 10 further comprises a washer 13 removably disposed between the multi-jackbolt tensioner 20 and the bridge member 16, such that the washer 13 abuts the closed end 16b of the bridge member. The washer 13 is made from hardened steel and serves to prevent damage to the closed end surface of the bridge member 16 when the cap screws 22 are tightened in the tensioner 20.

[0047] The use of a multi-jackbolt tensioner 20 is beneficial as it allows the many advantages of this type of tensioner to be utilised in the present application. Therefore, the stud 14 may be tensioned to relatively large preload tensions by the application of only a relatively low torque to each of the cap screws 22. As a result, only simple hand tools or pneumatic devices need be used to load the bolted joint to the required tension. This improves safety for the installers, while also benefitting the environment as no heavy machinery (e.g. bulky and/or high pressure hydraulic or electrical compressors) are required saving power and expense.

[0048] Moreover, as multi-jackbolt tensioners tighten the stud in pure tension there is no torsional strain, which eliminates the possibility of thread galling, as commonly occurs with direct torquing methods.

[0049] An example operation of the tensioning apparatus 10 will now be discussed with reference to Figures 1 to 3. In use, the apparatus 10 tensions the stud 14 to a desired preload by applying torque to each of the cap screws 22. The bridge member 16 sits atop flange 24a of the bolted joint and covers the nut 12, which is threaded onto the stud 14 and tightened against the surface of the flange 24a. The hardened washer 13 sits between the bridge member 16 and the multi-jackbolt tensioner 20,

which is also threaded onto the stud 14 and rests against the washer 13 on top of the bridge member 16. When the stud 14 is placed under load, it is found that it elastically extends or stretches according to Hooke's Law within its elastic limit (i.e. it undergoes elastic deformation along its length). The desired preload in the stud 14 can be divided between the number of cap screws 22 in the tensioner 20, as the individual loads on the cap screws 22 combine to form the total load on the stud 14. By knowing the individual load required for each cap screw 22, a torque setting may be derived from established tables of load values, whereupon a simple hand tool (e.g. torque wrench) may be used to apply the required torque to each of the cap screws 22.

[0050] In the example of Figure 2, the cap screws 22 are simple hex nuts, which may be tightened with an Allen key or similar tool.

[0051] To ensure reliable tensioning of the bolted joint, the cap screws 22 are tightened in a careful sequence which avoids any non-symmetric loading of the cap screws. Therefore, a 'star' or 'swan' sequence for tightening the cap screws is preferably adopted, in that the cap screws are tightened in an order that preferably resembles the points on a star image, for example, diametrically opposite cap screws are tightened one after another so that symmetric loading of the jointed is achieved (cf. Figure 2).

[0052] After initial loading, it is found that since the stud 14 has extended, the nut 12 no longer abuts against the surface of the flange 24a. Indeed, in practice an air gap actually forms between the nut 12 and the flange 24a, as a result of the tension in the stud 14. The tommy bar 18 may then be re-inserted into the nut 12 to further tighten the nut to eliminate the air gap and enable the nut to bed down against the surface of the flange 24a. Additional tightening of the cap screws 22 may then be performed, with the above procedure being repeated as often as necessary until the desired preload is achieved in the stud 14.

[0053] Once the preload is attained, the cap screws 22 may then be relaxed as the tension in the stud 14 (due to its inherent elastic restoring force) maintains compression or loading of the bolted joint - as it essentially pulls the nut 12 towards nut 26. As shown in Figure 4, the tensioner 20, bridge member 16 and tommy bar 18 may then all be removed from the bolted joint, leaving the nut 12 in place to keep the flanges 24a and 24b together.

[0054] All components of the present apparatus are manufactured from high strength steel for safety and longevity of use, and each component may be covered with a protective coating to enhance corrosion and rust resistance. It should also be understood that no special training is required to use the present apparatus and therefore even semi-skilled operators or those with little engineering experience would be able to implement the present invention.

[0055] Moreover, the present apparatus may be used in conjunction with load indicating devices, particularly

the load indicating washer disclosed in copending application no. PCT/GB2012/052114 and as manufactured by Clarkwood Engineering Ltd., UK.

[0056] As will be appreciated from the foregoing embodiments, the present invention is able to provide a simple, easy to fit/retro-fit, and cost-effective solution to reliably tension a mechanical joint to a desired preload. Therefore, although the tensioning apparatus are ideally suited for ensuring an accurate and consistent tensioning of studs, bolts, threaded rods and shafts etc., it will be recognised that one or more of the principles of the invention may extend to other tensioning applications due, not least, to the inherent scalability of the apparatus.

[0057] The above embodiments are described by way of example only. Many variations are possible without departing from the invention.

Claims

1. An apparatus for tensioning a stud (14) in a bolted joint to a desired preload, the apparatus comprising:
 - a locking means (12) adapted for engagement with the stud;
 - a removable bridge member (16) arranged to at least partially enclose the locking means and to receive the stud therethrough;
 - a removable actuator (18) operable to actuate the locking means through the bridge member; and
 - removable tensioning means (20) configured to apply tension to a load bearing surface of the bridge member so as to transfer tension to the stud;
 - wherein the actuator is operable to lock the locking means when the desired preload in the stud is achieved, and
 - wherein the tensioning means comprises a jacking nut or a multi-jackbolt tensioner consisting of a plurality of jackbolts or cap screws.
2. The apparatus of Claim 1, wherein the locking means is a threaded nut.
3. The apparatus of Claim 1 or Claim 2, wherein the nut comprises at least one radial bore hole through the body of the nut.
4. The apparatus of Claim 3, wherein the nut comprises a plurality of radial bore holes.
5. The apparatus of any preceding claim, wherein the bridge member comprises at least one aperture through which the actuator may releasably engage with the locking means.
6. The apparatus of Claim 5, when dependent on Claim

3 or Claim 4, wherein the actuator comprises an elongate rod adapted to engage with at least one of the radial bore holes.

7. The apparatus of any preceding claim, further comprising a washer removably disposed between the tensioning means and the bridge member.
8. The apparatus of any preceding claim, wherein the bridge member has a second surface for engaging with the bolted joint.

Patentansprüche

1. Vorrichtung zum Spannen einer Stiftschraube (14) in einer Schraubenverbindung auf eine gewünschte Vorspannung, wobei die Vorrichtung umfasst:
 - ein Verriegelungsmittel (12), das zum Eingreifen in die Stiftschraube geeignet ist;
 - ein lösbares Brückenglied (16), das angeordnet ist, um das Verriegelungsmittel mindestens teilweise zu umschließen und die Stiftschraube dadurch aufzunehmen;
 - ein lösbares Stellglied (18), das funktionsfähig ist, um das Verriegelungsmittel durch das Brückenglied zu betätigen; und
 - ein lösbares Spannmittel (20), das gestaltet sind, um eine Spannung auf eine tragende Fläche des Brückenglieds anzuwenden, so dass die Spannung auf die Stiftschraube übertragen wird;
 - wobei das Stellglied funktionsfähig ist, um das Verriegelungsmittel zu verriegeln, wenn die gewünschte Vorspannung in der Stiftschraube erreicht ist, und
 - wobei das Spannmittel eine Abdrückmutter oder einen Mehrfach-Abdrückbolzenspanner umfasst, der aus einer Vielzahl von Abdrückbolzen oder Kopfschrauben besteht.
2. Vorrichtung nach Anspruch 1, wobei das Verriegelungsmittel eine Gewindemutter ist.
3. Vorrichtung nach Anspruch 1 oder Anspruch 2, wobei die Mutter mindestens eine radiale Bohrung durch den Körper der Mutter aufweist.
4. Vorrichtung nach Anspruch 3, wobei die Mutter eine Vielzahl von radialen Bohrungen umfasst.
5. Vorrichtung nach einem vorhergehenden Anspruch, wobei das Brückenglied mindestens eine Öffnung umfasst, durch die das Stellglied lösbar in das Verriegelungsmittel eingreifen kann.
6. Vorrichtung nach Anspruch 5, wenn abhängig von

Anspruch 3 oder Anspruch 4, wobei das Stellglied einen länglichen Stab umfasst, der geeignet ist, in mindestens eine der radialen Bohrungen einzugreifen.

7. Vorrichtung nach einem vorhergehenden Anspruch, ferner umfassend eine Unterlegscheibe, die lösbar zwischen dem Spannmittel und dem Brückenglied angeordnet ist.
8. Vorrichtung nach einem vorhergehenden Anspruch, wobei das Brückenglied eine zweite Oberfläche zum Eingreifen in die Schraubenverbindung aufweist.

5

10

15

Revendications

1. Un appareil de mise en tension d'un goujon (14) dans un joint boulonné sur une précharge souhaitée, l'appareil comprenant :

20

un moyen de verrouillage (12) adapté pour une mise en prise avec le goujon,

un élément pont amovible (16) agencé de façon à au moins partiellement enfermer le moyen de verrouillage et à recevoir le goujon au travers de celui-ci,

25

un actionneur amovible (18) conçu de façon à actionner le moyen de verrouillage au travers de l'élément pont, et

30

un moyen de mise en tension amovible (20) configuré de façon à appliquer une tension à une surface portante de l'élément pont de façon à transférer une tension vers le goujon,

où l'actionneur est conçu de façon à verrouiller le moyen de verrouillage lorsque la précharge souhaitée dans le goujon est atteinte, et

35

où le moyen de mise en tension comprend un écrou de levage ou un tendeur à boulons d'écartement multiples se composant d'une pluralité de boulons d'écartement ou de vis à tête hexagonale.

40

2. L'appareil selon la Revendication 1, où le moyen de verrouillage est un écrou fileté.

45

3. L'appareil selon la Revendication 1 ou 2, où l'écrou comprend au moins un trou radial au travers du corps de l'écrou.

50

4. L'appareil selon la Revendication 3, où l'écrou comprend une pluralité de trous radiaux.

5. L'appareil selon l'une quelconque des Revendications précédentes, où l'élément pont comprend au moins une ouverture au travers de laquelle l'actionneur peut entrer en prise de manière libérable avec le moyen de verrouillage.

55

6. L'appareil selon la Revendication 5, lorsqu'elle dépend de la Revendication 3 ou 4, où l'actionneur comprend une tige allongée adaptée de façon à entrer en prise avec au moins un des trous radiaux.

7. L'appareil selon l'une quelconque des Revendications précédentes, comprenant en outre une rondelle disposée de manière amovible entre le moyen de mise en tension et l'élément pont.

8. L'appareil selon l'une quelconque des Revendications précédentes, où l'élément pont possède une deuxième surface destinée à entrer en prise avec le joint boulonné.

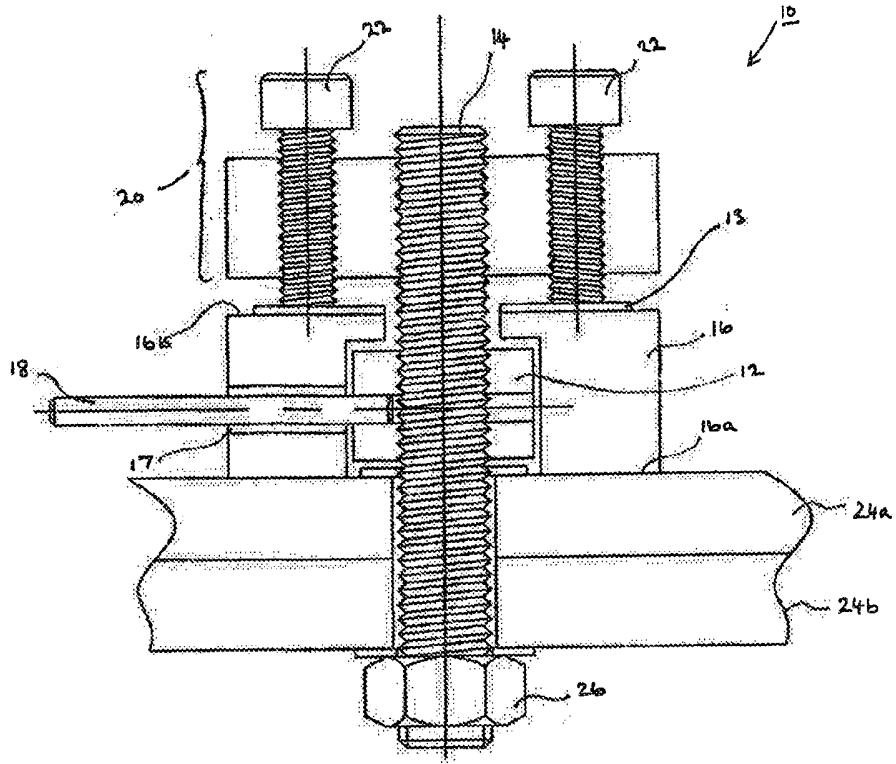

FIGURE 1

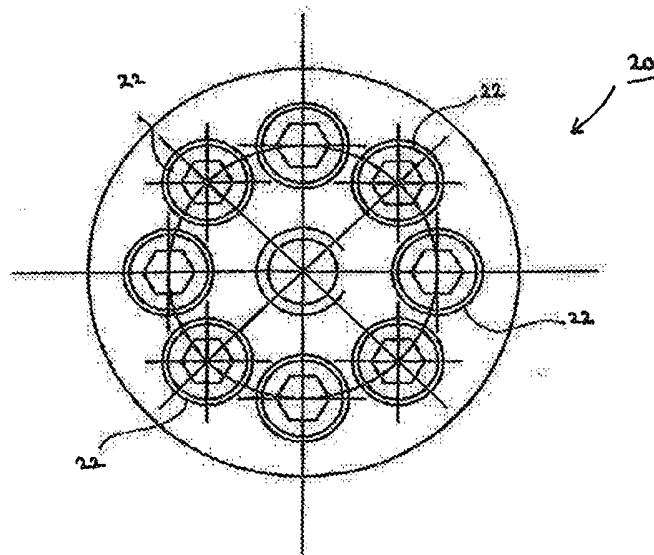

FIGURE 2

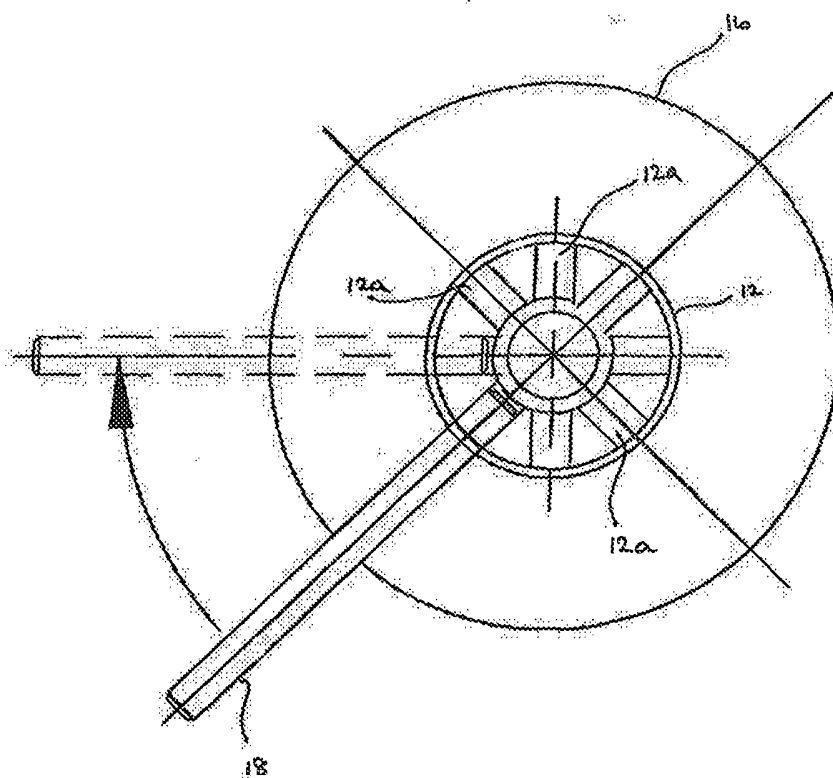

FIGURE 3

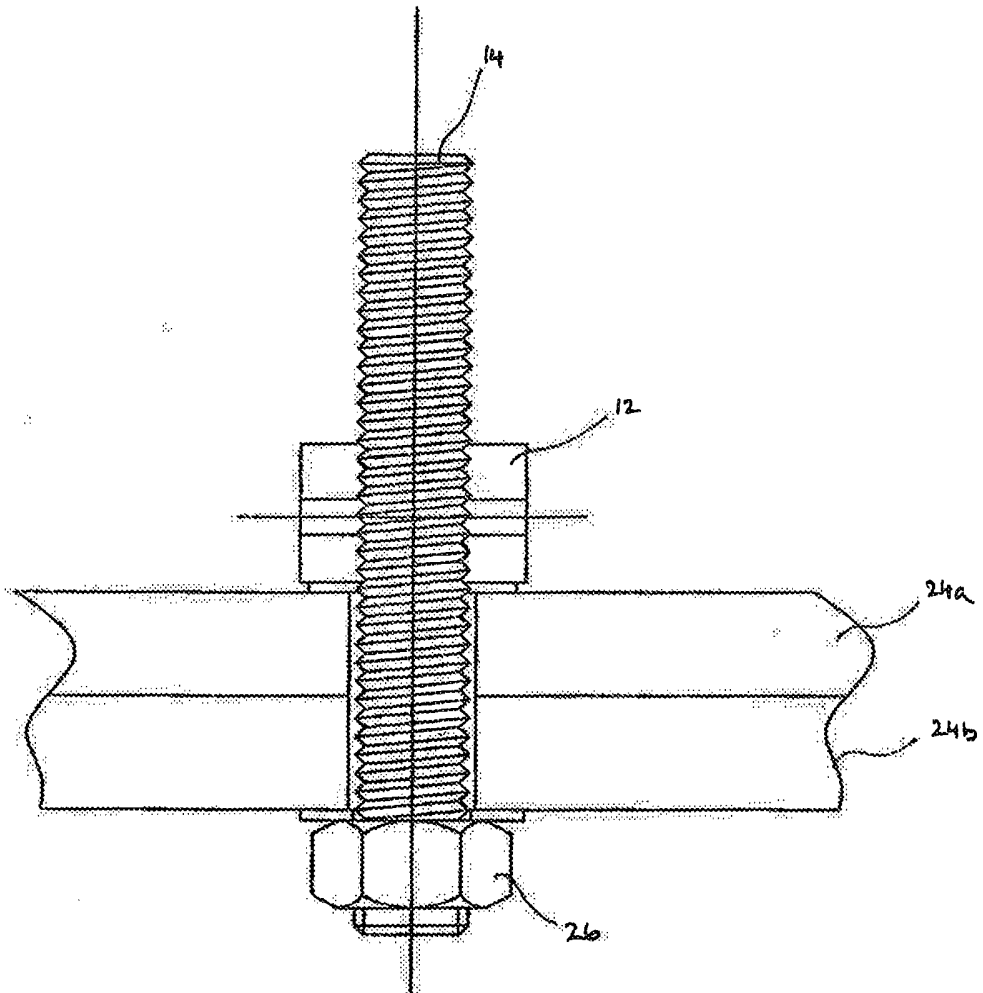

FIGURE 4

EP 2 794 192 B1

REFERENCES CITED IN THE DESCRIPTION

This list of references cited by the applicant is for the reader's convenience only. It does not form part of the European patent document. Even though great care has been taken in compiling the references, errors or omissions cannot be excluded and the EPO disclaims all liability in this regard.

Patent documents cited in the description

- DE 202008012922 [0001]
- GB 2012052114 W [0055]

FESZÍTŐSZERKEZET

Szabadalmi igénypontok

1. Szerkezet tőcsavar (14) egy kívánt előfeszítettségi állapotúra történő feszítéséhez egy csavarkapcsolatban, amely szerkezetnek van:
 - egy reteszelőeszköze (12), amely alkalmas a tőcsavarba kapcsolódásra;
 - egy oldható hídtagja (16), amely oly módon van elrendezve, hogy a reteszelőeszközt legalább részben körülzárja, és ezáltal a tőcsavart befogadja, illetve felveszi;
 - egy oldható, illetve elmozgatható állító, illetve szabályozó tagja (18), amely oly módon működtethető, hogy a reteszelőeszköz a hídtag révén legyen működtetve;
 - egy oldható, illetve mozgatható feszítőeszköze (20), amely oly módon van kialakítva, hogy a hídtagnak egy tartófelületére feszítést fejtsen ki, úgyhogy a feszültség továbbítva legyen a tőcsavarra;
 - mimellett az állítótag oly módon működtethető, hogy reteszelje a reteszelőeszközt, amikor a kívánt előfeszítés a tőcsavarban bekövetkezett; és
 - mimellett a feszítőeszköz egy (le)szorító anyát, vagy pedig egy többszörös leszorítócsap-feszítőt tartalmaz, amely több leszorítócsapból vagy fejcsavarból áll.
2. Az 1. igénypont szerinti szerkezet, ahol a reteszelőeszköz menetes anya.
3. Az 1. vagy 2. igénypont szerinti szerkezet, ahol az anya legalább egy, az anya testén átmenő radiális furatot tartalmaz.

4. A 3. igénypont szerinti szerkezet, ahol az anya több radiális furatot tartalmaz.

5. Az előző igénypontok bármelyike szerinti szerkezet, ahol a hídtagnak legalább egy nyílást tartalmaz, amelyen keresztül az állítótag oldhatóan kapcsolódhat a reteszelőszerkezetbe.

6. Az 5. igénypont szerinti szerkezet, amikor függ a 3. vagy 4. igényponttól, ahol az állítótag egy hosszúkás rúd, amely alkalmas arra, hogy a radiális furatok legalább egyikébe kapcsolódjék.

7. Az előző igénypontok bármelyike szerinti szerkezet, ahol az továbbá egy alátétlemezt tartalmaz, amely oldhatóan van a feszítőeszköz és a hídtagnak között elrendezve.

8. Az előző igénypontok bármelyike szerinti szerkezet, ahol a hídtagnak van egy második felülete a csavarkapcsolatba való csatlakozáshoz.

A meghatalmazott:

ADVOPATENT
SZABADALMI ÉS VÉDELMI IRODA
1255 Budapest, Pf. 80.
2.

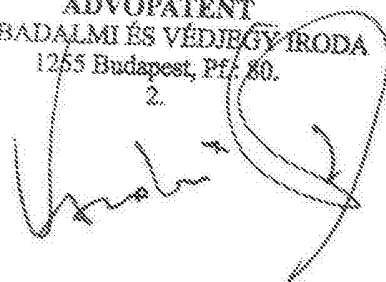
A handwritten signature in black ink is written over a circular stamp. The stamp contains the text 'ADVOPATENT SZABADALMI ÉS VÉDELMI IRODA 1255 Budapest, Pf. 80. 2.'.