

(No Model.)

2 Sheets—Sheet 2.

L. WOODRUFF. Stock Car.

No. 233,129.

Patented Oct. 12, 1880.

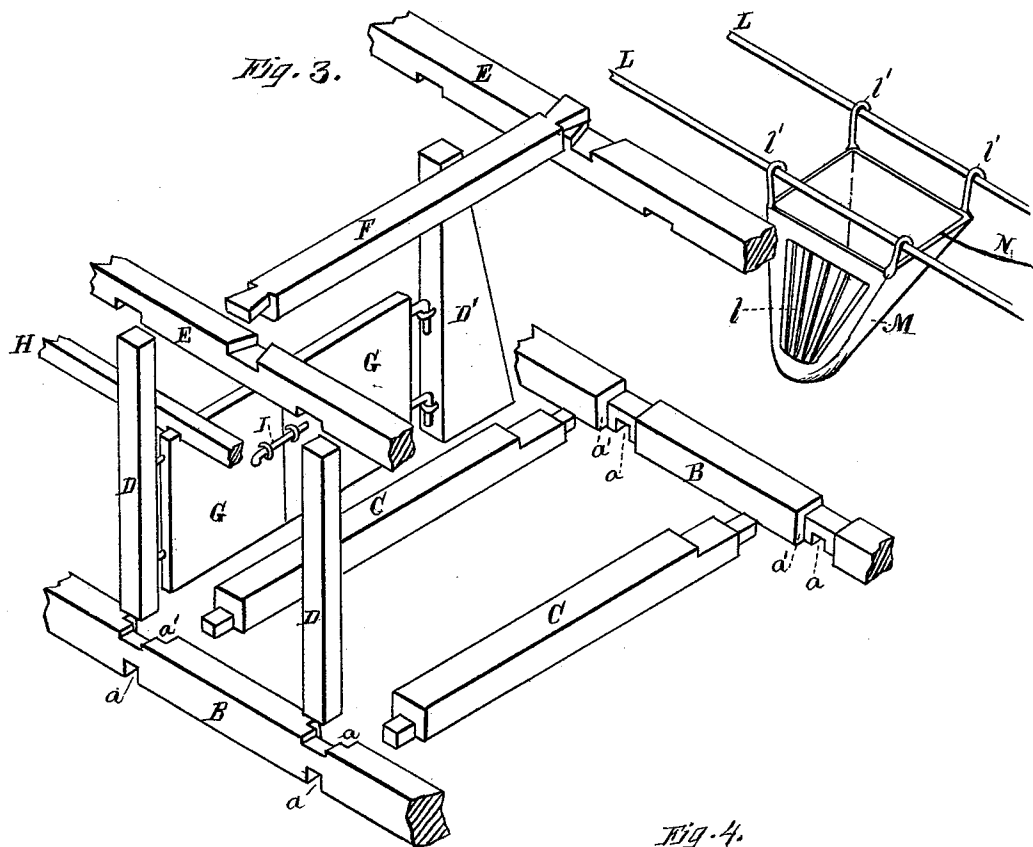
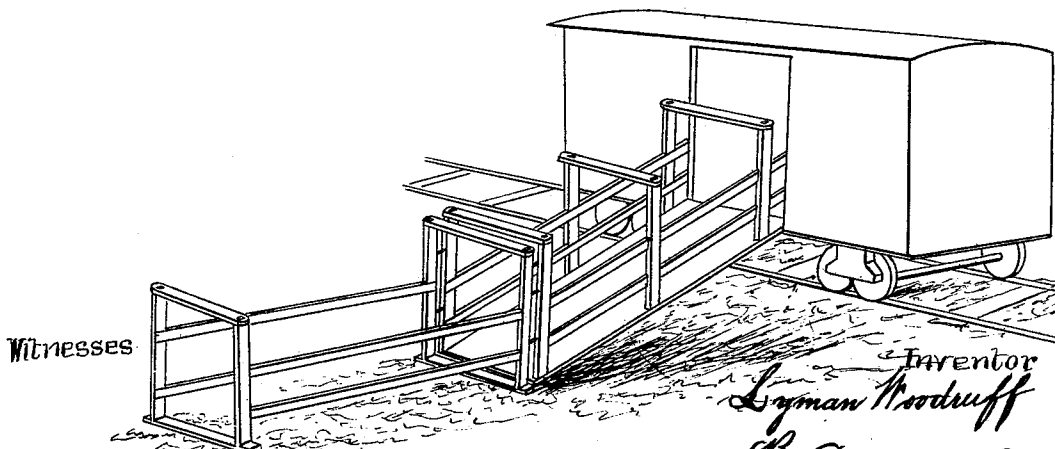

Fig. 4.



Witnesses

Frank A. Brooks
Geo. H. Strong

Inventor
Lyman Woodruff
By Dewey & Co. Attys

UNITED STATES PATENT OFFICE.

LYMAN WOODRUFF, OF ELLENSBURG, OREGON.

STOCK-CAR.

SPECIFICATION forming part of Letters Patent No. 233,129, dated October 12, 1880.

Application filed August 9, 1880. (No model.)

To all whom it may concern

Be it known that I, LYMAN WOODRUFF, of Ellensburg, county of Curry, and State of Oregon, have invented an Improvement in Stalls for Transporting Stock; and I hereby declare the following to be a full, clear, and exact description thereof.

The object of my invention is to provide a series of stalls in which live stock may be transported on cars or vessels and fed and watered by the way; and my improvements consist in certain details of construction whereby the stalls can be taken apart and set up at will, and be accommodated to suit the space at disposal, as is more fully described in the accompanying drawings.

Figure 1 is a longitudinal section of a car, showing my arrangement. Fig. 2 is a transverse section. Fig. 3 shows the manner of framing. Fig. 4 shows the portable chute or gangway.

A represents a car in which the stalls are formed. The sills B are made of the length of the car. Notches *a* are formed in these sills equidistant from each other, and as far apart as the width of each stall. Grooves *a'* are also cut on the sides of the sills, into which the cross-pieces C fit, the stanchions D fitting into the notches *a*, and the cross-pieces C being dovetailed into the sills. The stanchions D' on one side are beveled off, as shown, next to the feed-boxes. Plates E are set on these stanchions, and braces F, crossing the car, are dovetailed into the plates, the whole frame being thus strongly made and secured together, but susceptible of being taken apart whenever desired.

The partitions G are hinged to the stanchions D', and have catches or bolts *g* at their opposite ends, which shoot into hasps or staples on the posts D, to hold said partitions in place. Removable notched braces H fit on either end of these partitions, to strengthen them and hold them in place. These partitions rest on the lower cross-pieces. One or more of these movable partitions or gates is divided in the middle and hinged to the opposite stanchions on each side, with clamps I in the center for securing the parts. One of these divided gates is placed on each side of the car-door, in order that the long partitions can be swung clear

when the stalls are close together. These partitions are opened in putting cattle in or taking them out, but are shut when the cattle are in place for transit.

A water-box, J, is placed lengthwise the car, in front of the stalls, and has a cover, J', with a cord, K, which leads outside the car, so the water-box may be opened and closed without having to enter the car. Above the water-box are two rods, L L. On these are suspended canvas sacks M, narrower at the bottom than the top, and open at the top. On the inner sides of these are slats *l*, like those in an ordinary manger. The sacks have hooks *l'*, for sliding on the rods, and a cord, N, is rove from the outer sack through a sheave or eye and leads back to the platform.

As the sacks are all joined one to another, after the sacks are filled from the platform, by drawing in the cord they are hauled out in front of the stalls in a position for the animals in each stall to get at them for food.

This apparatus is intended for long shipments.

The feed can be carried overhead in the car, and transferred to the feed-bags as desired.

The whole frame-work of these stalls, being made with dovetailed joints, can be set up in any desired space, and removed at will. The stalls also form pens in which sheep and hogs can be carried, and one tier can be made over another, if desired. These stalls can be set up, as described, on a vessel's deck, if desired, as well as on a car.

The sills, braces, cross-pieces, stanchions, &c., are all removable, so the stalls can be taken apart, and the whole placed in compact space when not in use.

With these stalls I use a portable chute, through which the cattle may be driven single to the car-door, and which may be taken apart and put together.

Having thus described my invention, what I claim as new, and desire to secure by Letters Patent, is—

1. The cattle-transporting stalls consisting of the notched and grooved sills B, cross-pieces C, stanchions D D', plates E, and braces F, and the swinging partitions or gates G, with their catches *g*, and removable notched braces H, all arranged so as to be taken apart and

put together when desired, substantially as and for the purpose herein described.

2. In combination with the stalls consisting of the sills, cross-pieces, stanchions, plates, and braces, as shown, the swinging double partitions or gates G, provided with bolts I and braces H, whereby the divisions of the stalls are formed in such a manner that the cattle may move from one stall to another in being put in or taken out, while when in place they are kept separate, substantially as and for the purpose herein described.

3. In combination with the cattle-transport-

ing stalls, as shown, the movable feed-bags M, with their slats *l* and hooks *l'*, adapted to hold the bags on the rods L L, and the cord N, whereby the feed may be placed in front of the cattle without the attendant having to pass into the car, substantially as herein described.

In witness whereof I have hereunto set my hand.

LYMAN WOODRUFF.

Witnesses:

WALTER SUTTON,

WILLIS T. WHITE.