

(No Model.)

C. T. SHADBOLT.

CHURN.

No. 309,410.

Patented Dec. 16, 1884.

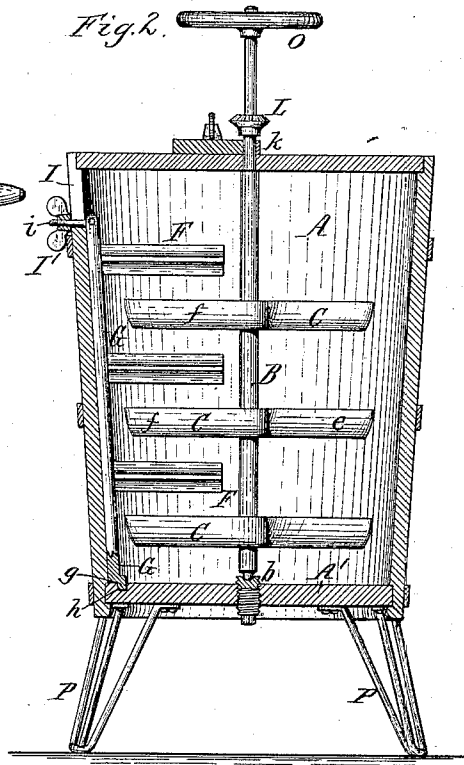
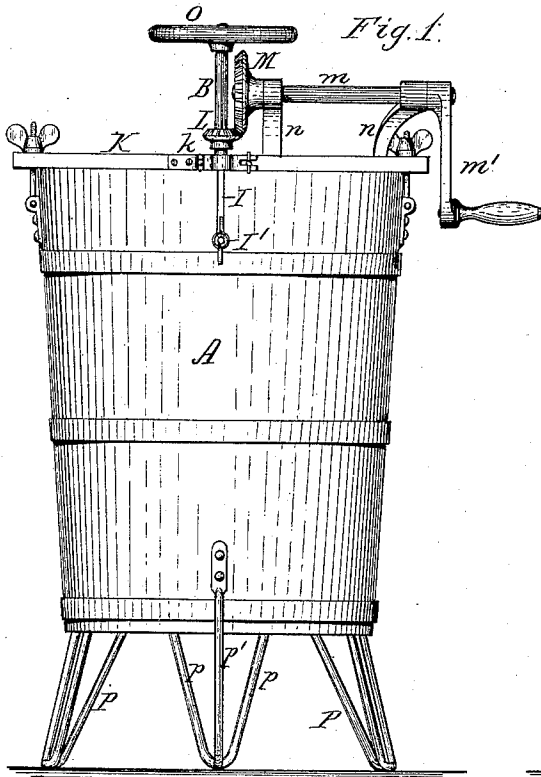

Fig. 3.

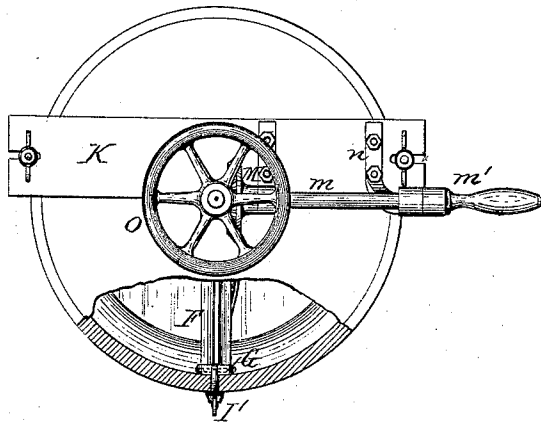
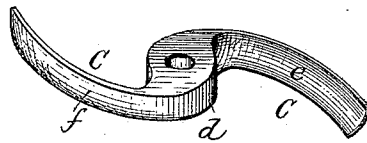

Fig. 4.



Chas. J. Buchheit
 Edw. J. Brady
 Witnesses.

Chas. T. Shadbolt, Inventor.
 By Wilhelm & Bonner.
 Attorneys.

UNITED STATES PATENT OFFICE.

CHARLES T. SHADBOLT, OF ATTICA, NEW YORK.

CHURN.

SPECIFICATION forming part of Letters Patent No. 309,410, dated December 16, 1884.

Application filed May 17, 1880. (No model.)

To all whom it may concern:

Be it known that I, CHARLES T. SHADBOLT, of Attica, in the county of Wyoming and State of New York, have invented new and useful Improvements in Churns, of which the following is a specification, reference being had to the accompanying drawings.

This invention relates more especially to that class of churns which contain horizontal dasher-arms revolving around a perpendicular shaft and passing through the spaces between stationary breaker-arms, which are secured to the inner side of the tub—as, for instance, in the churn described and shown in Letters Patent of the United States No. 130,730, dated August 20, 1872.

The object of my invention is to render the churn more efficient and convenient in operation; and it consists of the particular construction of the means whereby the bar carrying the stationary arms is secured to the inner side of the tub, as will be hereinafter fully set forth.

In the accompanying drawings, Figure 1 is a side elevation of my improved churn. Fig. 2 is a vertical section at right angles to Fig. 1. Fig. 3 is a top plan view of my improved churn with a part of the cover removed. Fig. 4 is a perspective view of a pair of dasher-arms.

Like letters of reference refer to like parts in the several figures.

A represents the churn case or tub, of ordinary form.

B represents the perpendicular shaft, arranged centrally in the tub A, and supported with its lower end in a step-bearing formed by a screw, *b*, projecting upwardly through the bottom A' of the tub.

C represents the horizontal dasher-arms, secured to the vertical shaft B. The arms C are arranged in pairs upon the shaft B, each pair being preferably cast in one piece on diametrically-opposite sides of a common hub, *d*, through which the shaft B passes. The arms B are curved forwardly, or in the direction in which they move, whereby the cream is moved toward the middle of the tub. The front or face side of each arm is made concave, as shown at *e*, and its rear side is made convex,

parallel with the concave face, as shown at *f*. By this construction of the arms the waves which are caused by them, and the open air-spaces in the rear of these waves, are increased in size, and a more intimate contact of the air with the butter-globules is effected thereby. The several pairs of arms are arranged on the shaft B, one above the other, at suitable distances apart, and secured to the shaft by dowelpins, set-screws, or keys, as may be preferred.

F represents the stationary breaker-arms, which extend radially from the side of the tub toward the middle thereof, and which are arranged in line with the spaces between the arms C, so that the latter in rotating will pass through the spaces between the stationary arms F. The latter are preferably made diamond-shaped in cross-section, and are cast in one piece with an upright strip or bar, G, fitted against the inner side of the tub.

g is a stud or pin projecting from the lower end of the bar G into a socket, *h*, formed in the bottom of the tub, whereby the lower end of the bar G is held in place.

i is a screw-bolt attached to the upper end of the bar G, and projecting outwardly through a slot, I, formed in the tub, wherein it is secured by a thumb-nut, I'. Upon removing the cover of the tub and releasing the thumb-nut I' the bar G, with the stationary arms F attached thereto, can be lifted out of the tub, whereby the cleaning of these parts is greatly facilitated. The slot I is closed to prevent the escape of cream through the same by extending the bar G up to the cover, or by attaching a strip of suitable size to the under side of the cover in a position to close the slot I when the cover is closed.

K represents the bridge-piece, which extends diametrically across the top of the tub, and which is provided with a bearing, *k*, in which the shaft B is held.

L is a gear-pinion mounted on the shaft B above the bridge-piece K, and M is a gear-wheel meshing with the pinion L, and secured to the inner end of a horizontal shaft, *m*, which is provided at its opposite end with a hand-crank, *m'*. The shaft *m* is supported in bearings *n*, secured to the bridge-piece K. The shaft B is extended upward beyond the wheel

M, and provided with a hand-wheel, O, by which the dasher-arms may be rotated when the consistency of the material in the churn reaches a point where their rotation by means of the crank *m'* becomes inconvenient or impracticable.

P represents the legs on which the tub A rests. They are each composed of two bars, *p*, which are secured with their upper ends to the bottom of the tub, and a central bar, *p'*, which is secured with its lower end to the bars *p* at their junction, and with its upper end to the outer side of the tub, so as to serve

as a brace, the three bars together forming a light and rigid leg.

I claim as my invention—

The combination, with the tub A, provided with the slot I and socket *h*, of the removable bar G, provided with arms F, stud *g*, formed at the lower end of the bar G, screw-bolt *i*, attached to the upper end of the bar G, and thumb-nut *Y*, substantially as set forth.

C. T. SHADBOLT.

Witnesses:

JNO. J. BONNER,

CHAS. J. BUCHHEIT.