



US00D502136S

(12) **United States Design Patent**
Pfeiffer

(10) **Patent No.:** **US D502,136 S**

(45) **Date of Patent:** **** Feb. 22, 2005**

(54) **FRONT FACE OF A VEHICLE WHEEL**

D236,198 S * 8/1975 Clary D12/211
D441,708 S * 5/2001 Pfeiffer D12/211

(75) Inventor: **Peter Pfeiffer**, Boeblingen (DE)

* cited by examiner

(73) Assignee: **DaimlerChrysler AG**, Stuttgart (DE)

Primary Examiner—Stacia Cadmus

(**) Term: **14 Years**

(74) *Attorney, Agent, or Firm*—Crowell & Moring LLP

(21) Appl. No.: **29/190,714**

(57) **CLAIM**

(22) Filed: **Sep. 26, 2003**

The ornamental design for a front face of a vehicle wheel, as shown and described.

(30) **Foreign Application Priority Data**

Apr. 15, 2003 (DE) 403 02 981

DESCRIPTION

(51) **LOC (7) Cl.** **12-16**

FIG. 1 is a front view of a front face of a vehicle wheel according to my novel design; and,

(52) **U.S. Cl.** **D12/211**

FIG. 2 is a perspective view of the front face of a vehicle wheel according to my novel design.

(58) **Field of Search** D12/204-213;
301/37.101, 64.101, 65

The broken lines are for illustrative purposes only and form no part of the claimed design.

(56) **References Cited**

U.S. PATENT DOCUMENTS

D205,032 S * 6/1966 Reid D12/211

1 Claim, 1 Drawing Sheet

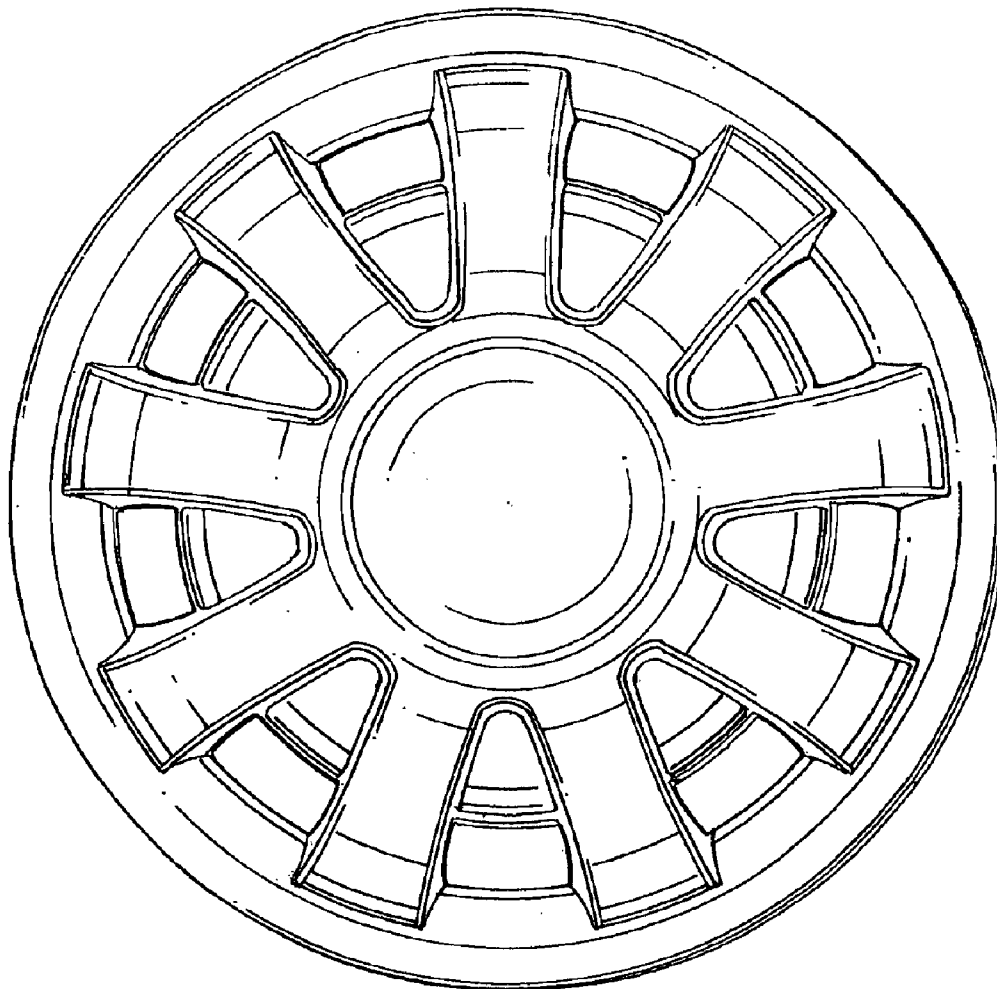

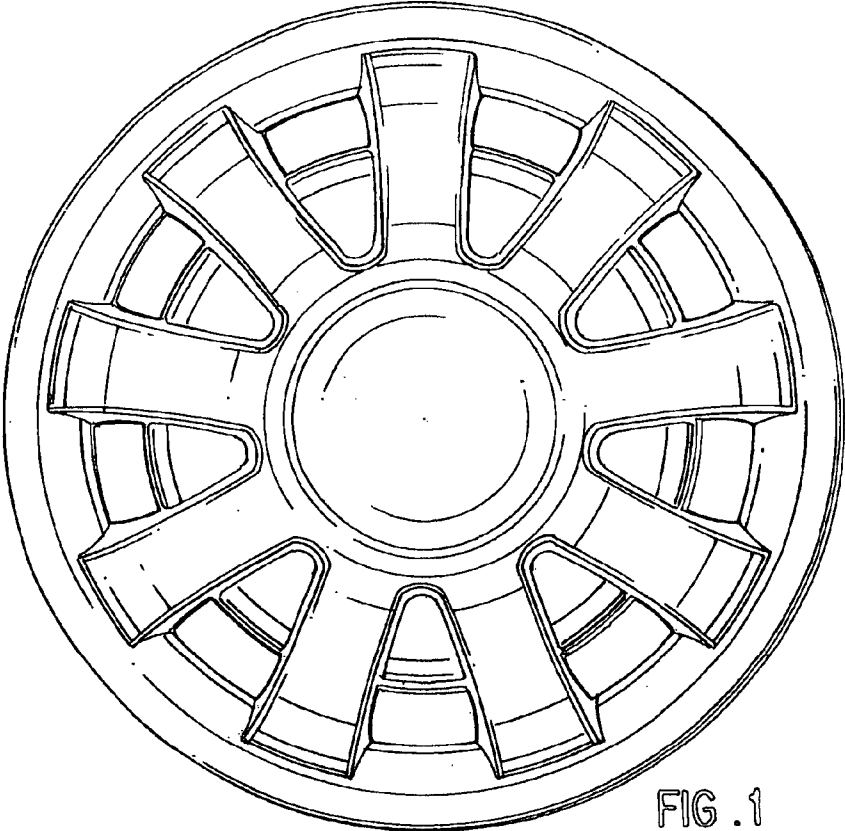

FIG. 1

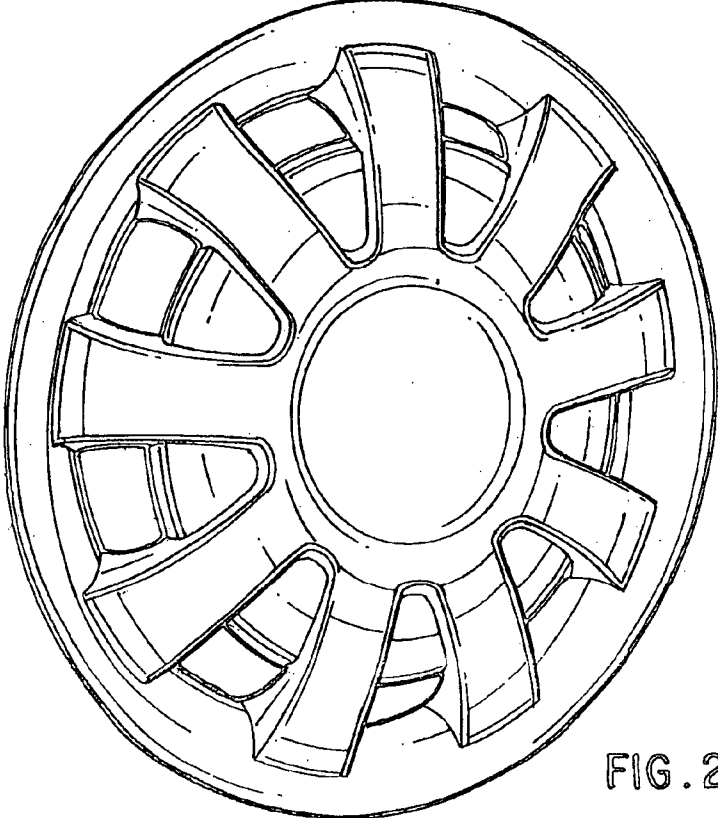

FIG. 2