



(19) **United States**

(12) **Patent Application Publication**
Zucherman et al.

(10) **Pub. No.: US 2008/0086212 A1**

(43) **Pub. Date: Apr. 10, 2008**

(54) **SPINE DISTRACTION IMPLANT**

(75) Inventors: **James F. Zucherman**, San Francisco, CA (US); **Ken Y. Hsu**, San Francisco, CA (US); **Charles J. Winslow**, Walnut Creek, CA (US); **Henry A. Klyce**, Piedmont, CA (US); **Scott A. Yerby**, Montara, CA (US); **John J. Flynn**, West Milford, NJ (US); **Steven T. Mitchell**, Pleasant Hill, CA (US); **John A. Markwart**, Castro Valley, CA (US)

(60) Provisional application No. 60/421,921, filed on Oct. 29, 2002. Provisional application No. 60/565,910, filed on Apr. 28, 2004. Provisional application No. 60/672,402, filed on Apr. 18, 2005.

Publication Classification

(51) **Int. Cl.**
A61F 2/44 (2006.01)
A61B 17/58 (2006.01)
(52) **U.S. Cl.** **623/17.11; 606/90**

Correspondence Address:
FITZPATRICK CELLA (MEDTRONIC)
30 ROCKEFELLER PLAZA
NEW YORK, NY 10112-3800 (US)

(57) **ABSTRACT**

(73) Assignee: **St. Francis Medical Technologies, Inc.**, Concord, CA

(21) Appl. No.: **11/788,763**

(22) Filed: **Apr. 19, 2007**

Related U.S. Application Data

(60) Continuation-in-part of application No. 11/092,862, filed on Mar. 29, 2005, which is a division of application No. 09/842,819, filed on Apr. 26, 2001, now Pat. No. 7,201,751, which is a continuation-in-part of application No. 09/579,039, filed on May 26, 2000, now Pat. No. 6,451,019, which is a continuation-in-part of application No. 09/473,173, filed on Dec. 28, 1999, now Pat. No. 6,235,030, which is a continuation of application No. 09/179,570, filed on Oct. 27, 1998, now Pat. No. 6,048,342, which is a continuation-in-part of application No. 08/958,281, filed on Oct. 27, 1997, now Pat. No. 5,860,977, which is a continuation-in-part of application No. 08/778,093, filed on Jan. 2, 1997, now Pat. No. 5,836,948. Continuation-in-part of application No. 10/684,847, filed on Oct. 14, 2003, now Pat. No. 7,306,628. Continuation-in-part of application No. 11/003,555, filed on Dec. 3, 2004. Continuation-in-part of application No. 11/389,002, filed on Mar. 24, 2006.

A spine distraction implant alleviates pain associated with spinal stenosis and facet arthropathy by expanding the volume in the spine canal and/or neural foramen. The implant provides a spinal extension stop while allowing freedom of spinal flexion. An interspinous process implant with a selectably expandable spacer can be placed between adjacent spinous processes. A device implanted between the spinous processes of adjacent vertebrae of the spine can be used for relieving pain associated with the vertebrae and surrounding tissues and structures by maintaining and/or adding distraction between adjacent vertebrae. A tissue expander can be adapted to move from a first insertion position, for ease of implantation between spinous processes, to a second retention position that prevents displacement of the implant. An embodiment of a system can include an implant having a spacer with a thickness and a wing, wherein a first configuration of the wing has a first height substantially similar to the thickness and wherein the wing is adapted to be selectably arranged in a second configuration such that the wing has a second height greater than the first height. A periphery of the implant has a shape generally conformal with a shape of an inner surface of a cannula and a cross-sectional diameter smaller than an inner diameter of the cannula. The cannula is inserted such that a proximal end of the cannula is arranged between the adjacent spinous processes. The implant is then urged into position between the adjacent spinous processes by way of the cannula, and subsequently arranged in a second configuration to fix the implant in position.

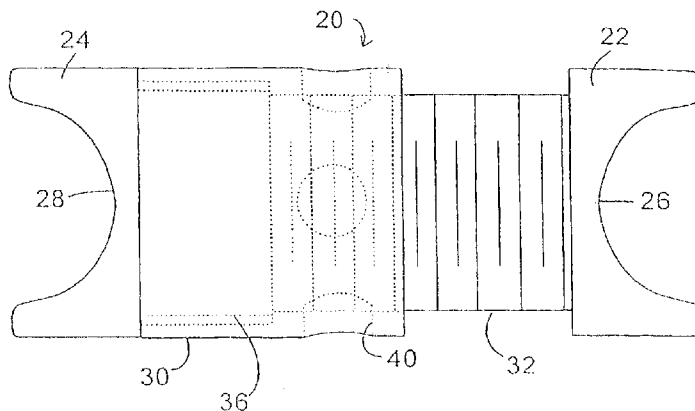

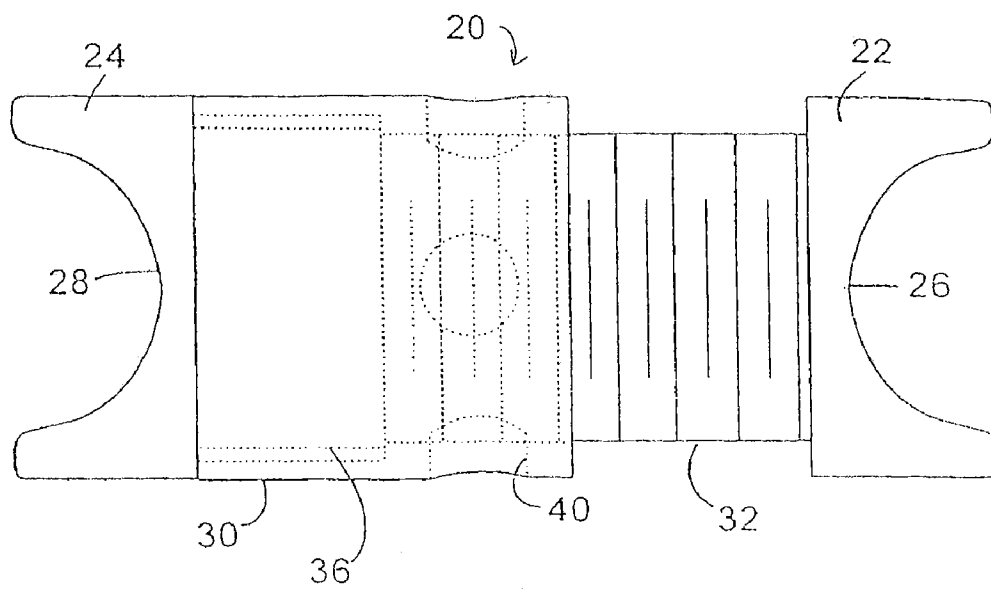

FIG. 1

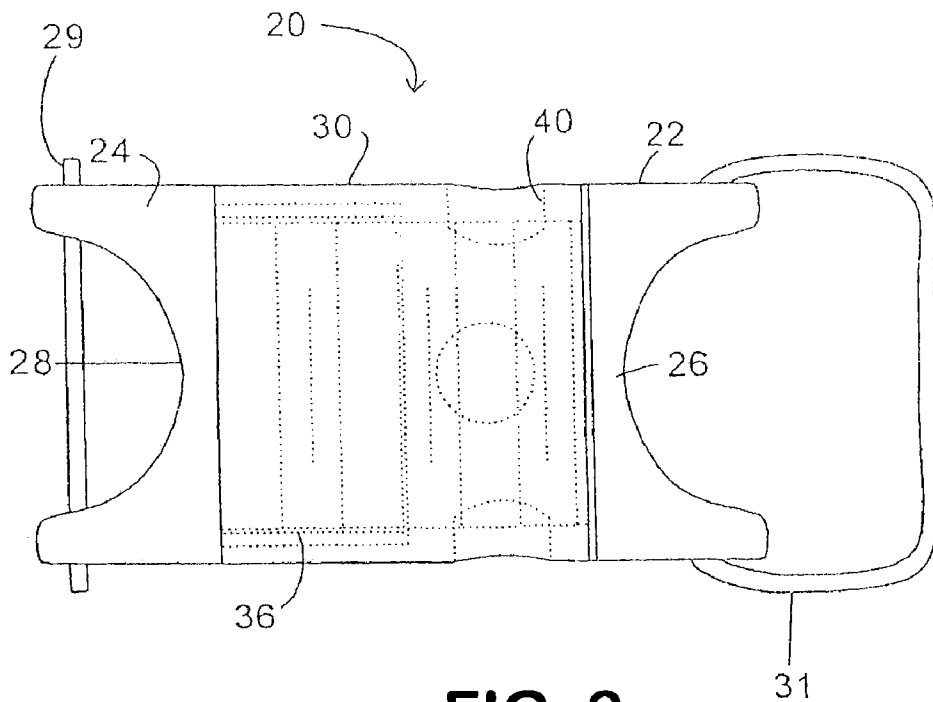

FIG. 2

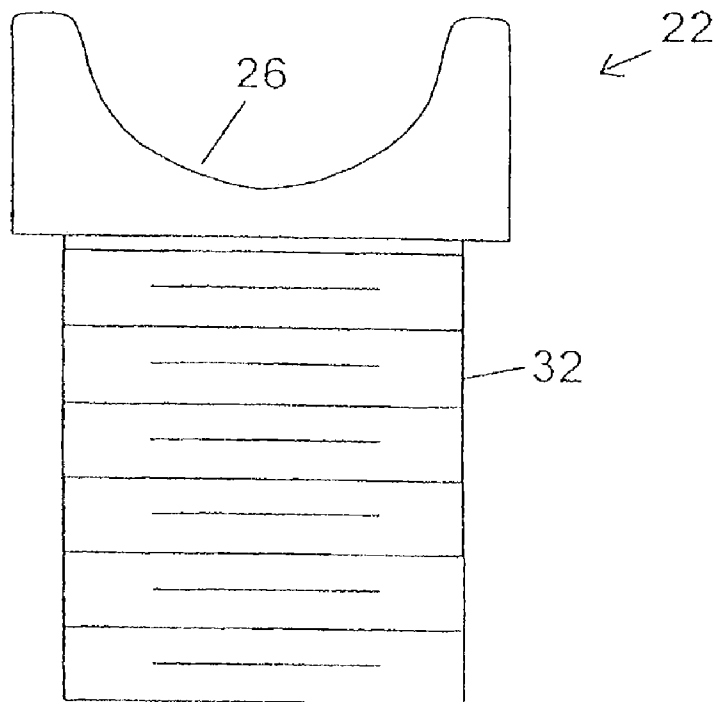

FIG. 3A

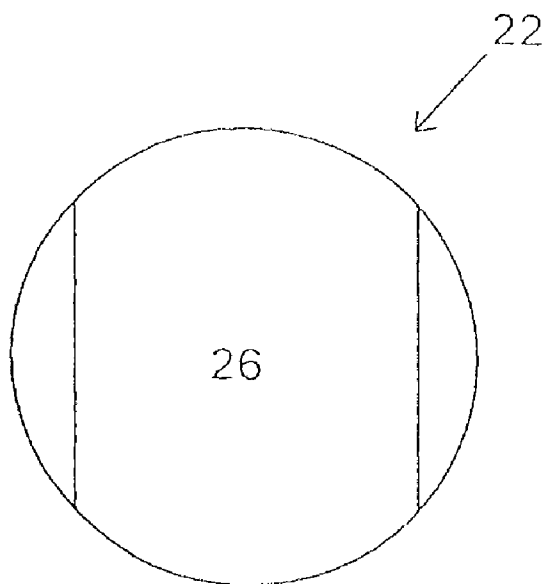

FIG. 3B

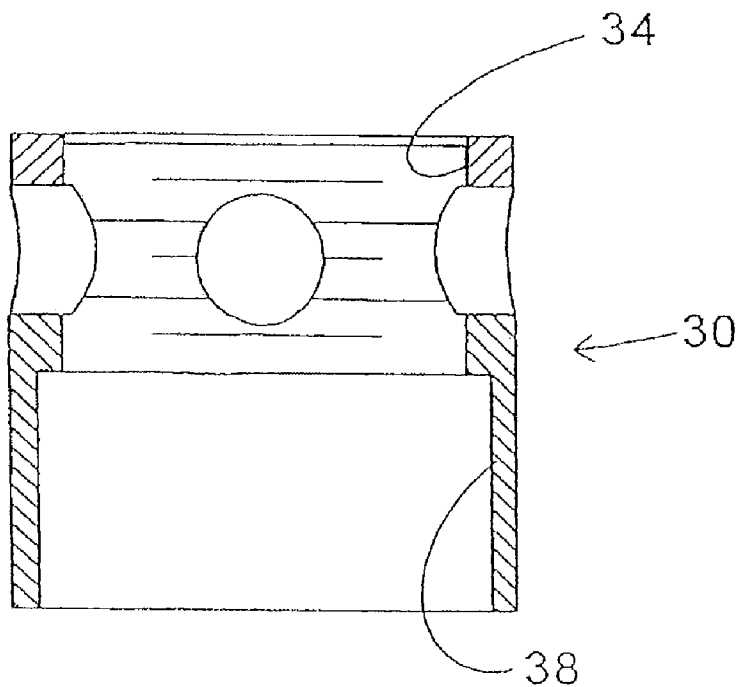

FIG. 4A

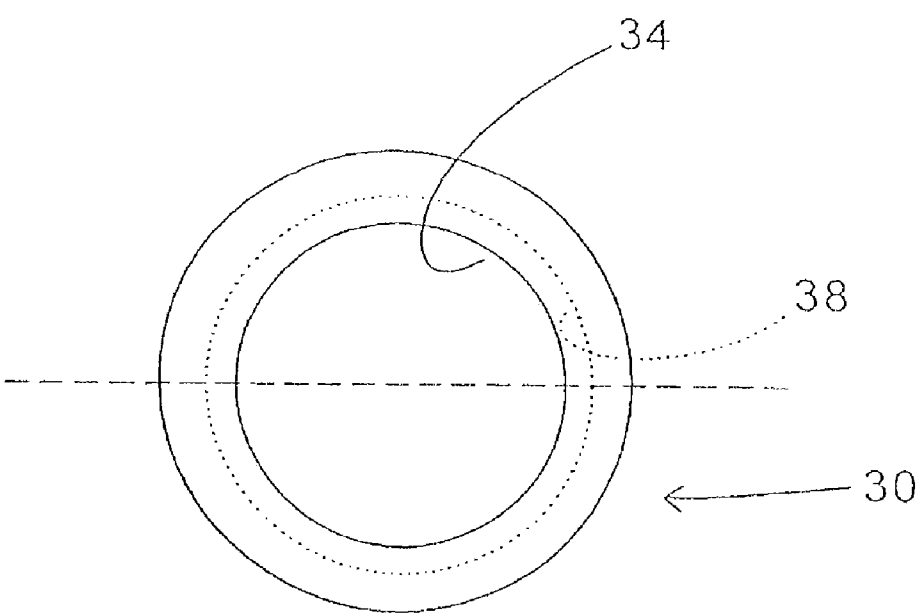

FIG. 4B

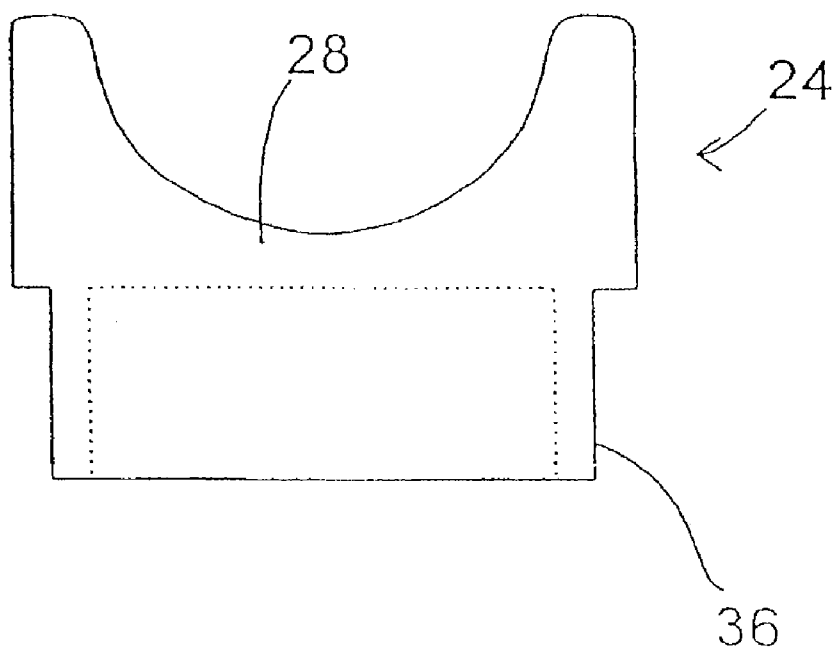

FIG. 5A

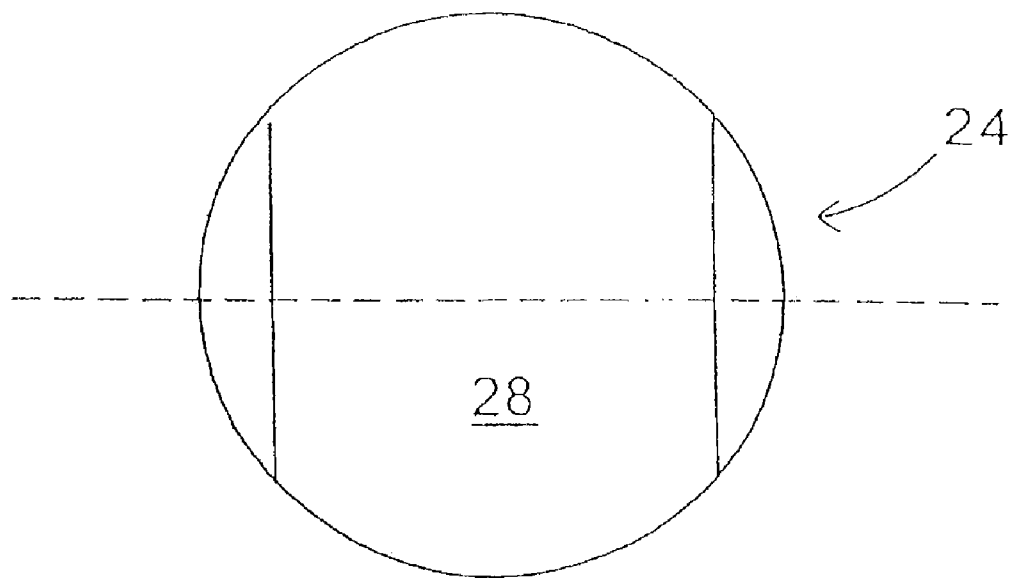

FIG. 5B

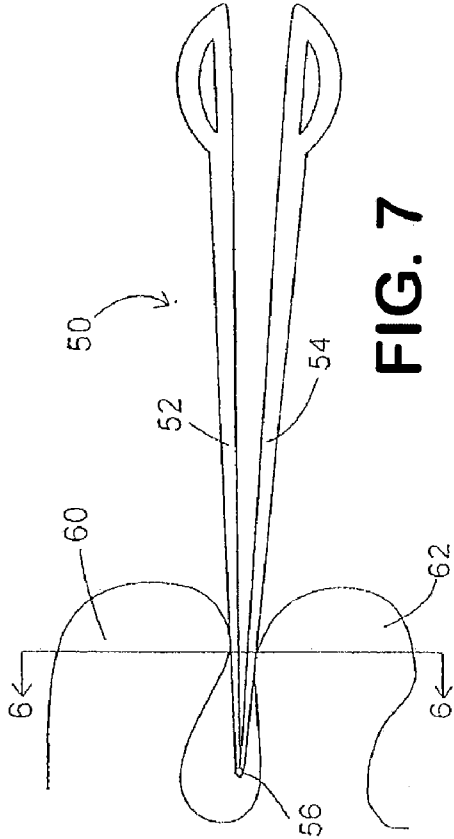
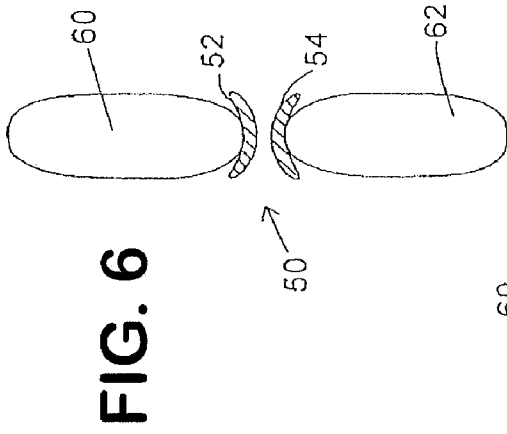

FIG. 7

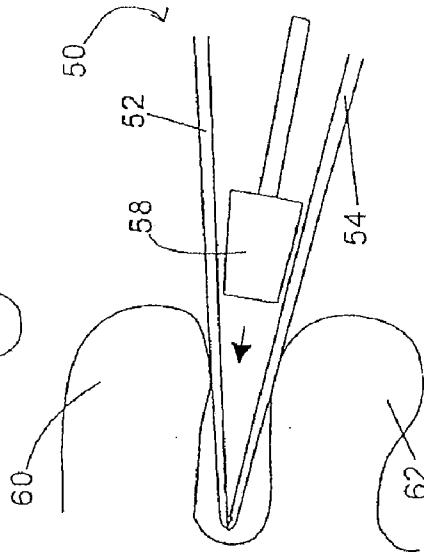

FIG. 8

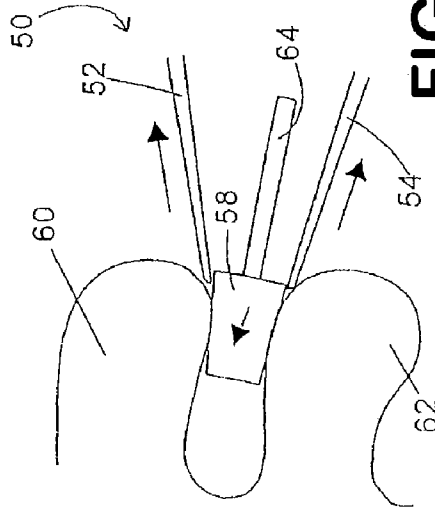

FIG. 9

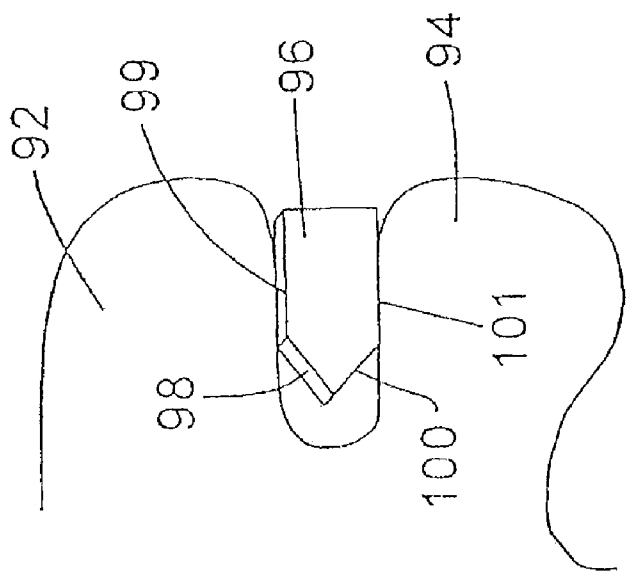

FIG. 10

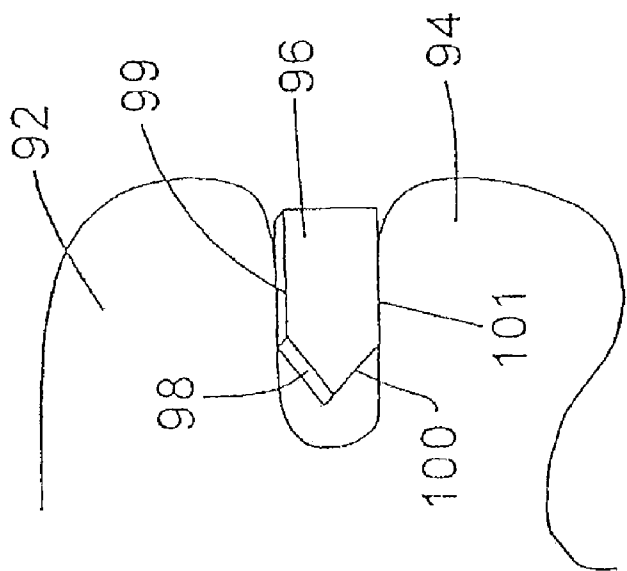

FIG. 11

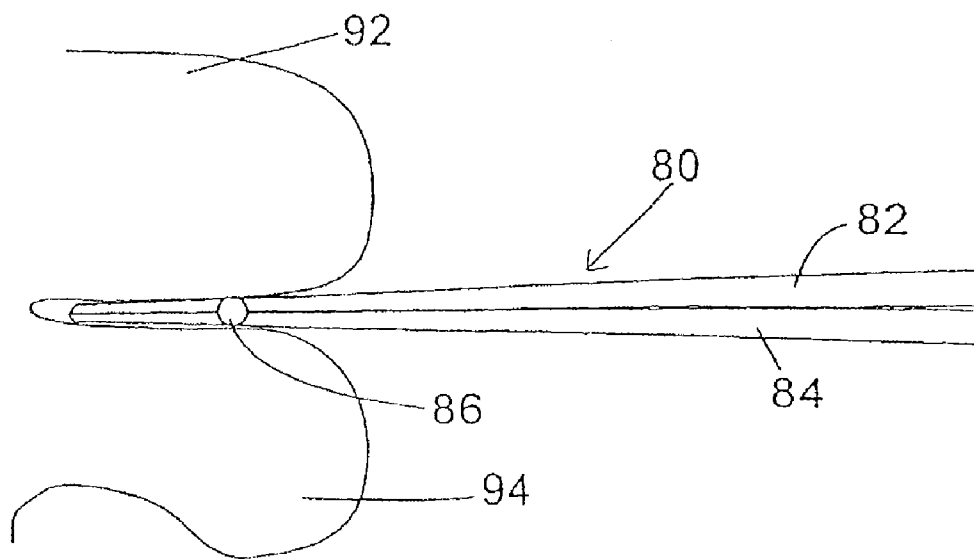

FIG. 12

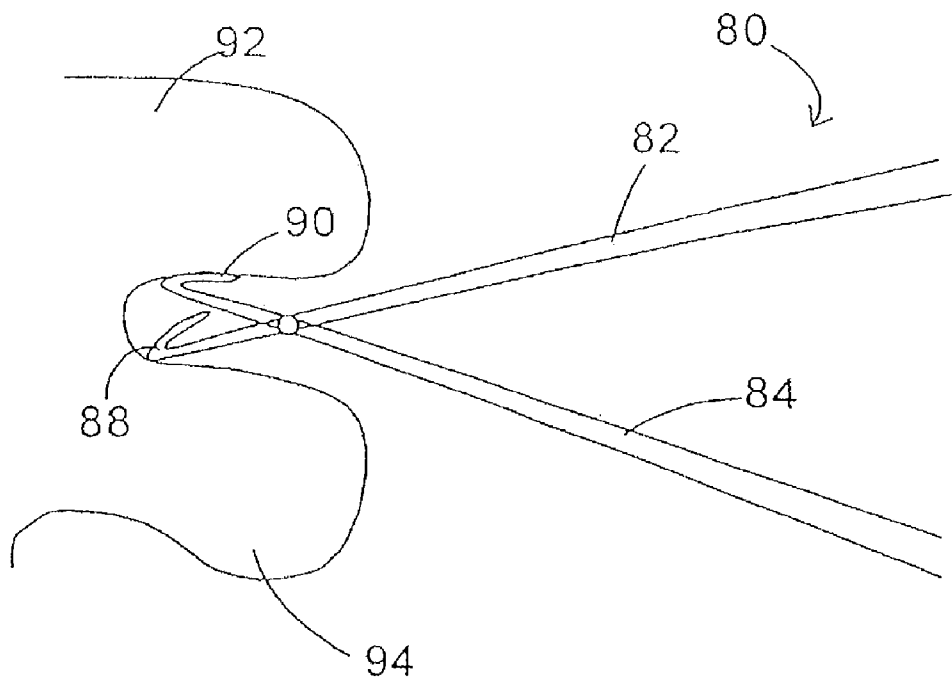

FIG. 13

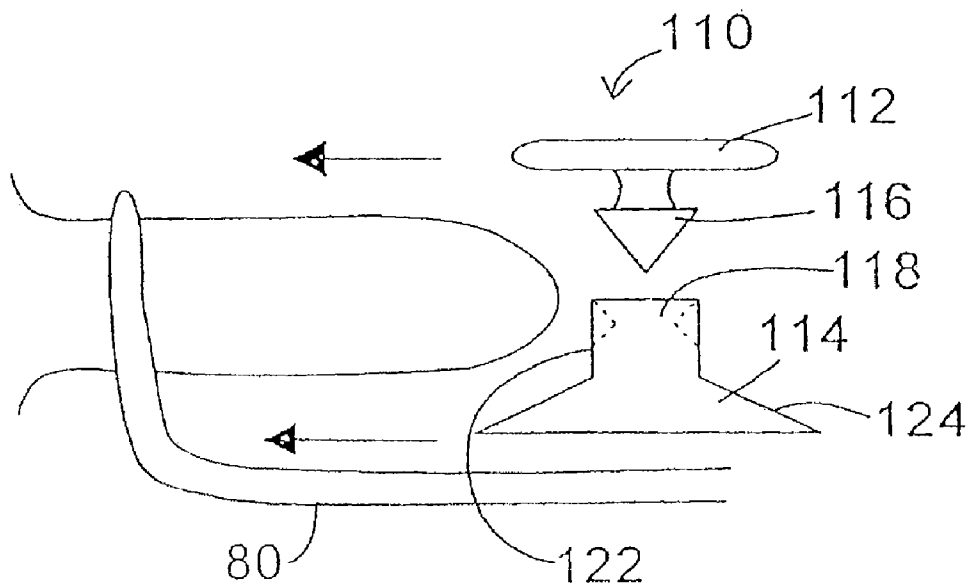

FIG. 14

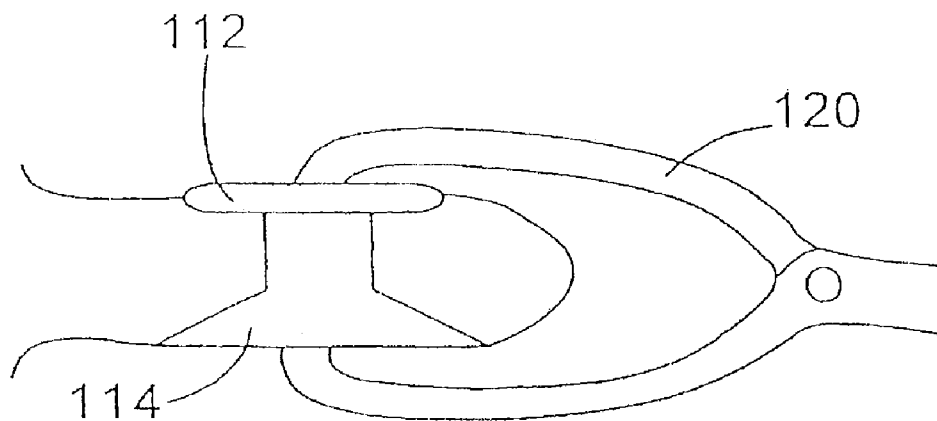

FIG. 15

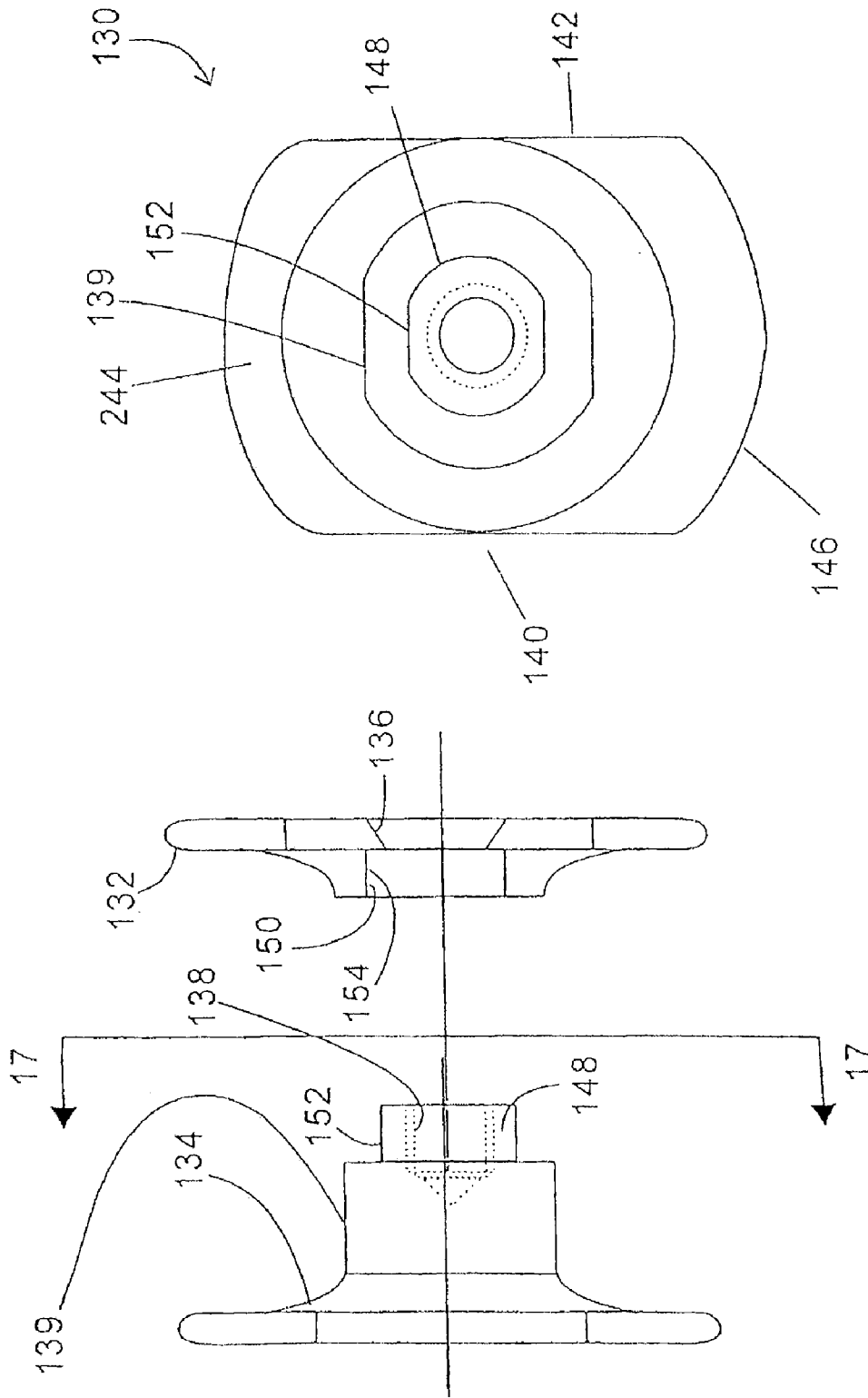

FIG. 17

FIG. 16

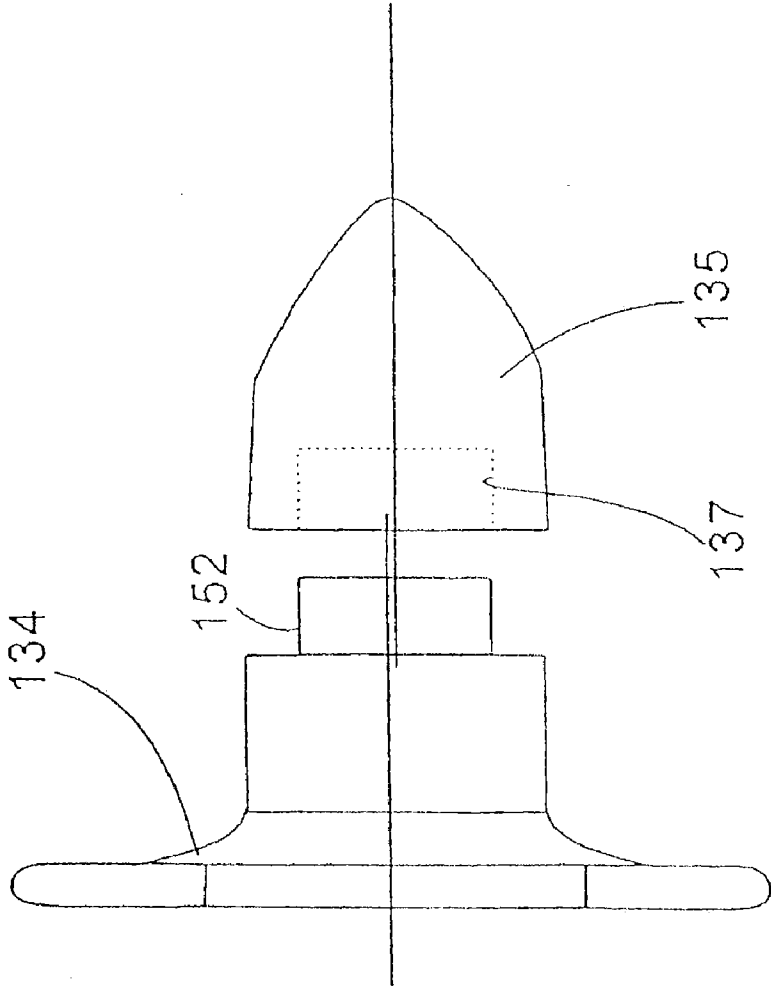

FIG. 16A

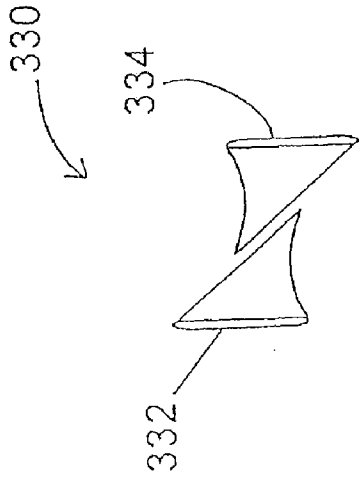

FIG. 18

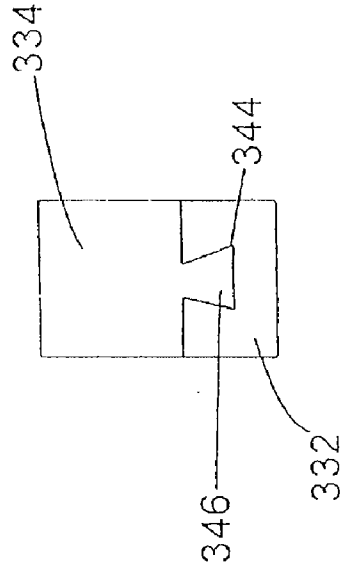

FIG. 19

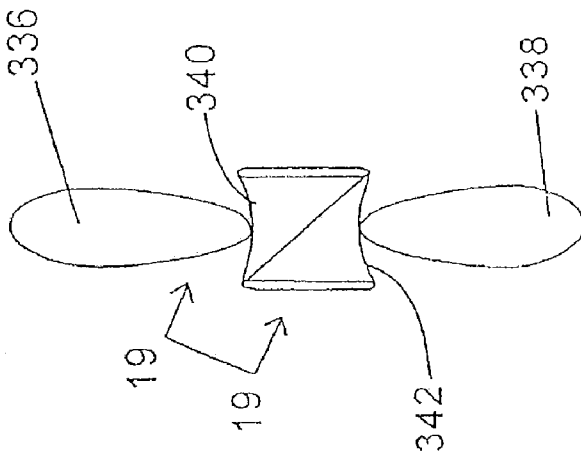

FIG. 20

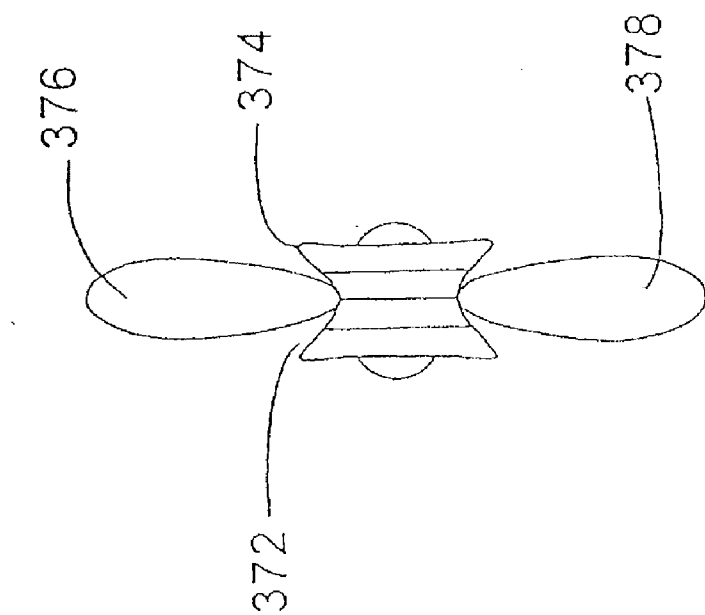

FIG. 22

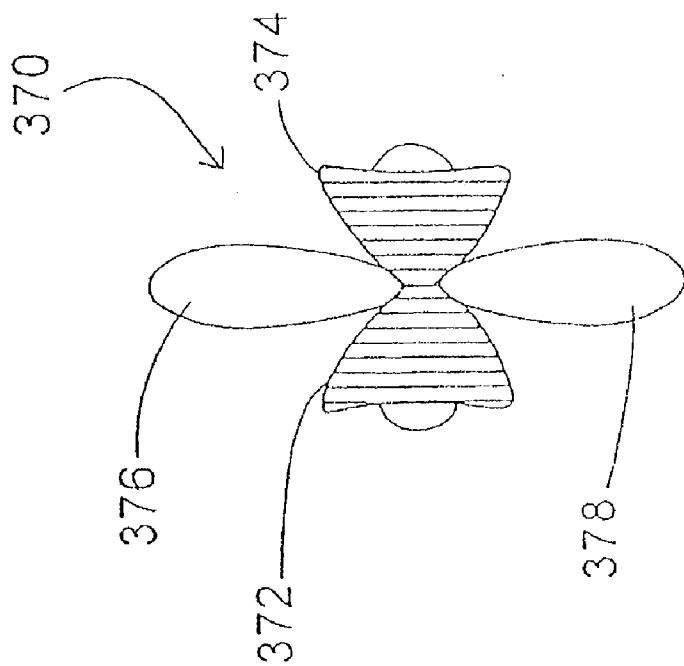

FIG. 21

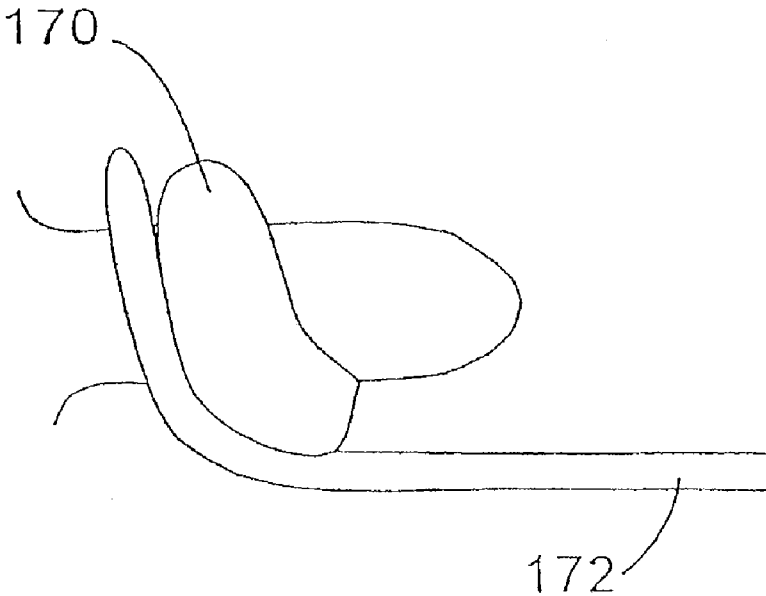

FIG. 24

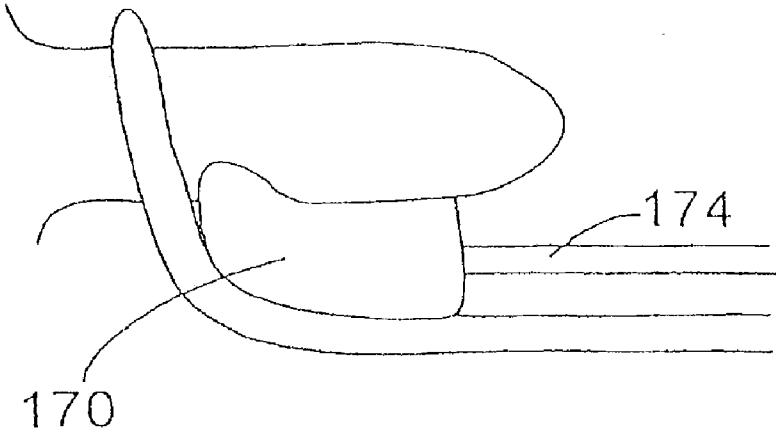

FIG. 23

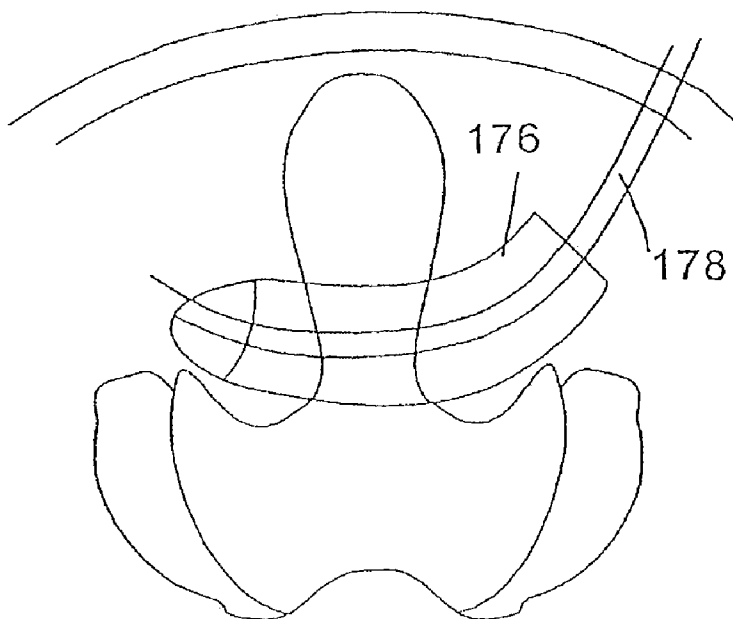

FIG. 25

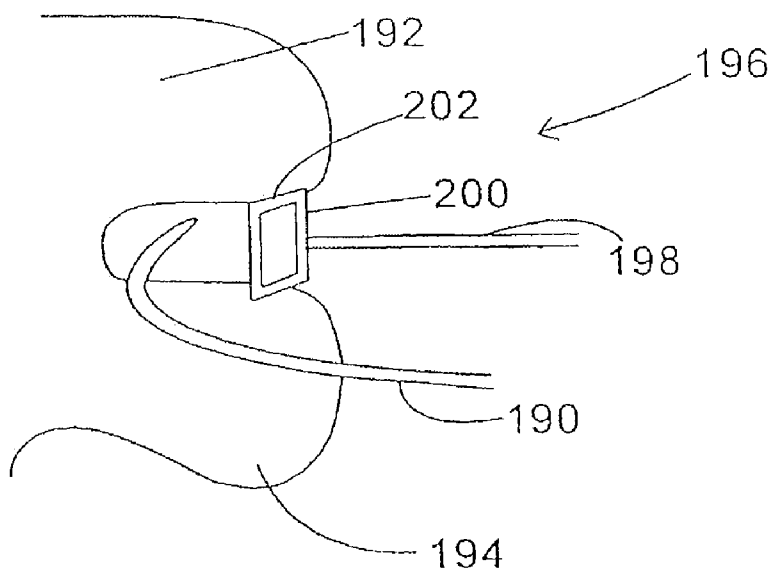

FIG. 26

FIG. 28

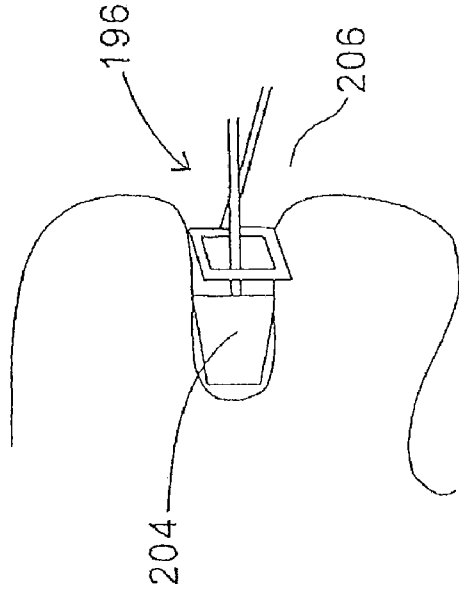

FIG. 30

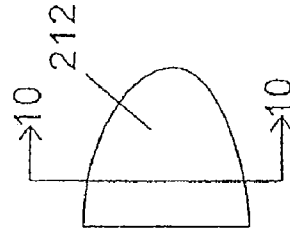

FIG. 27

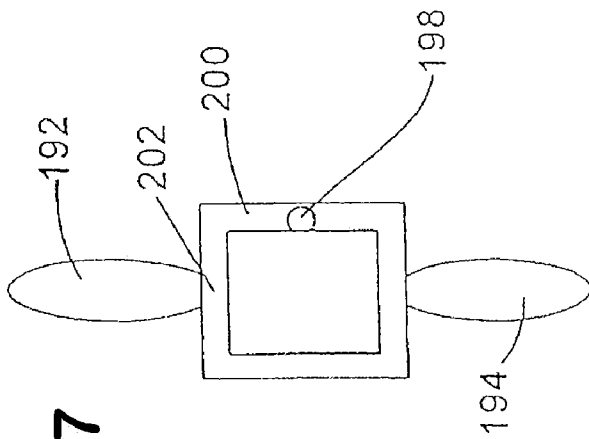
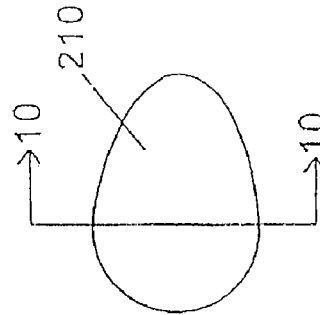

FIG. 29



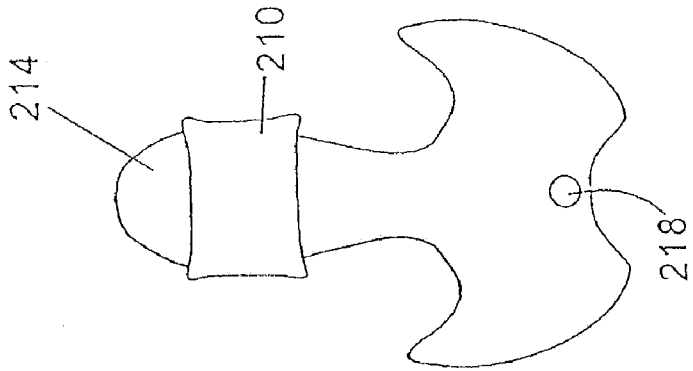

FIG. 31

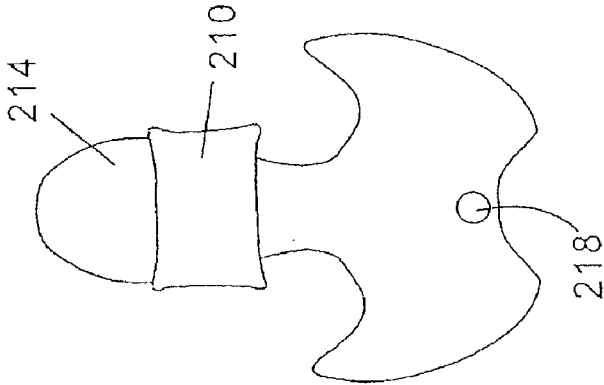

FIG. 32

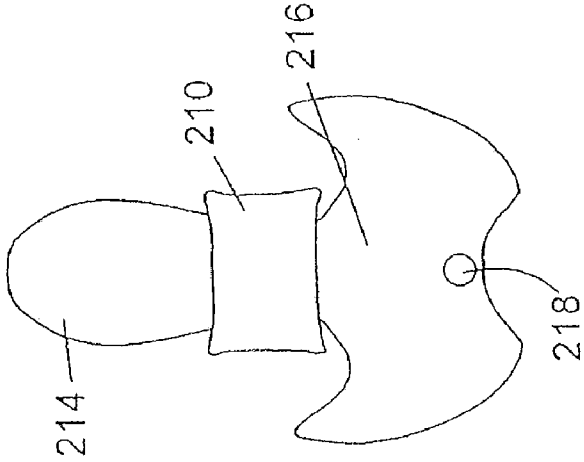

FIG. 33

FIG. 34

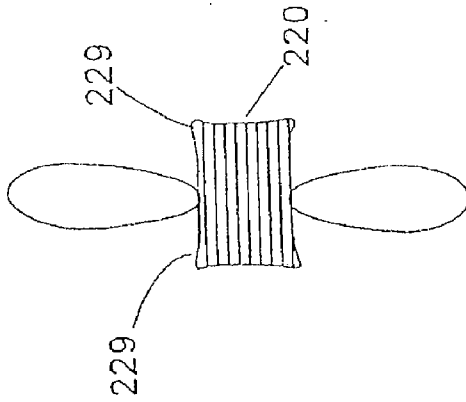

FIG. 35

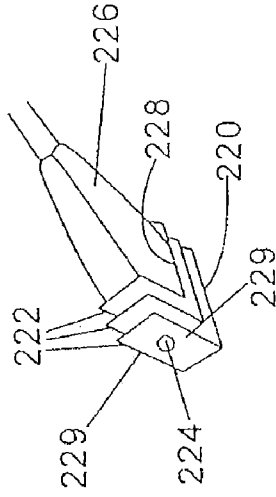

FIG. 36

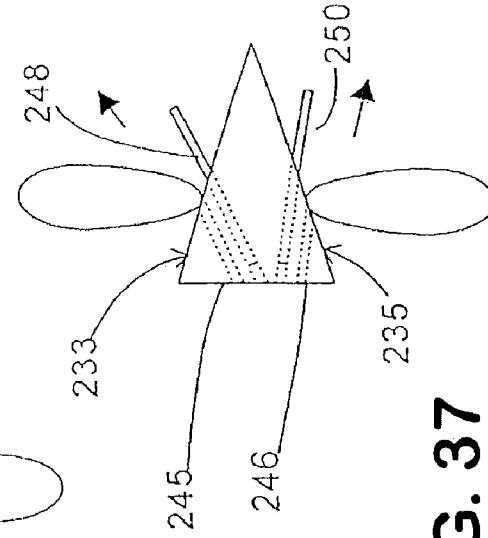
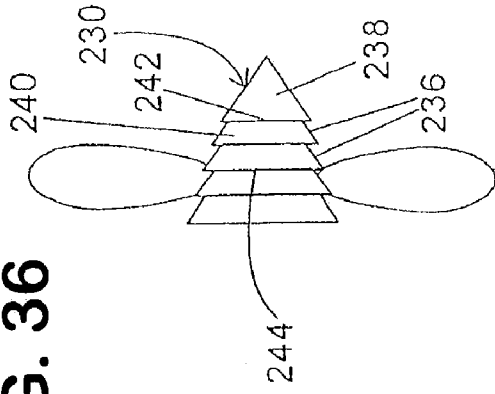

FIG. 37

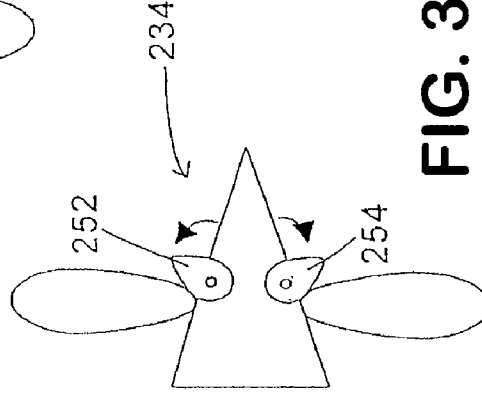
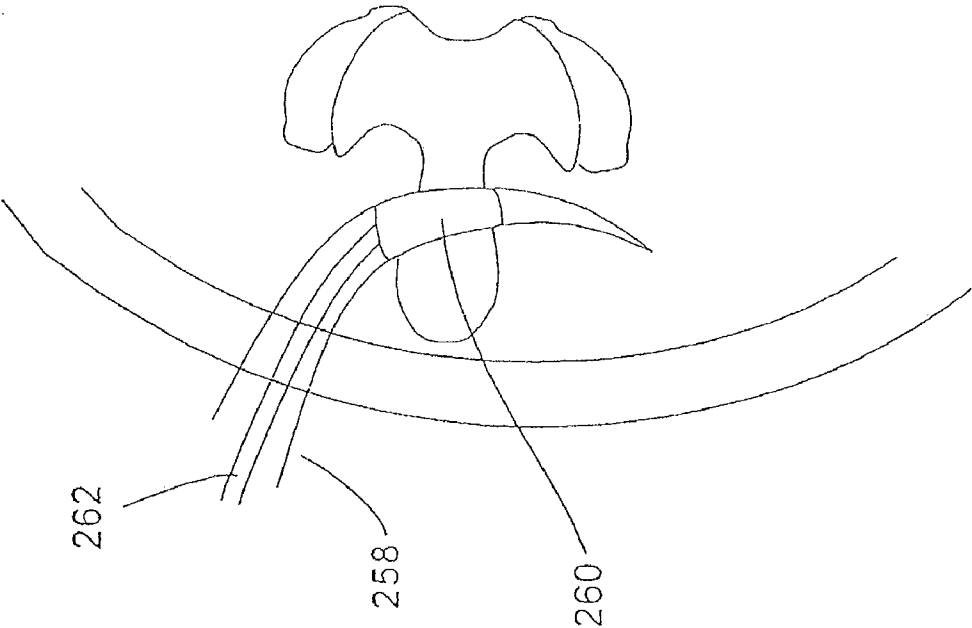

FIG. 38

FIG. 39



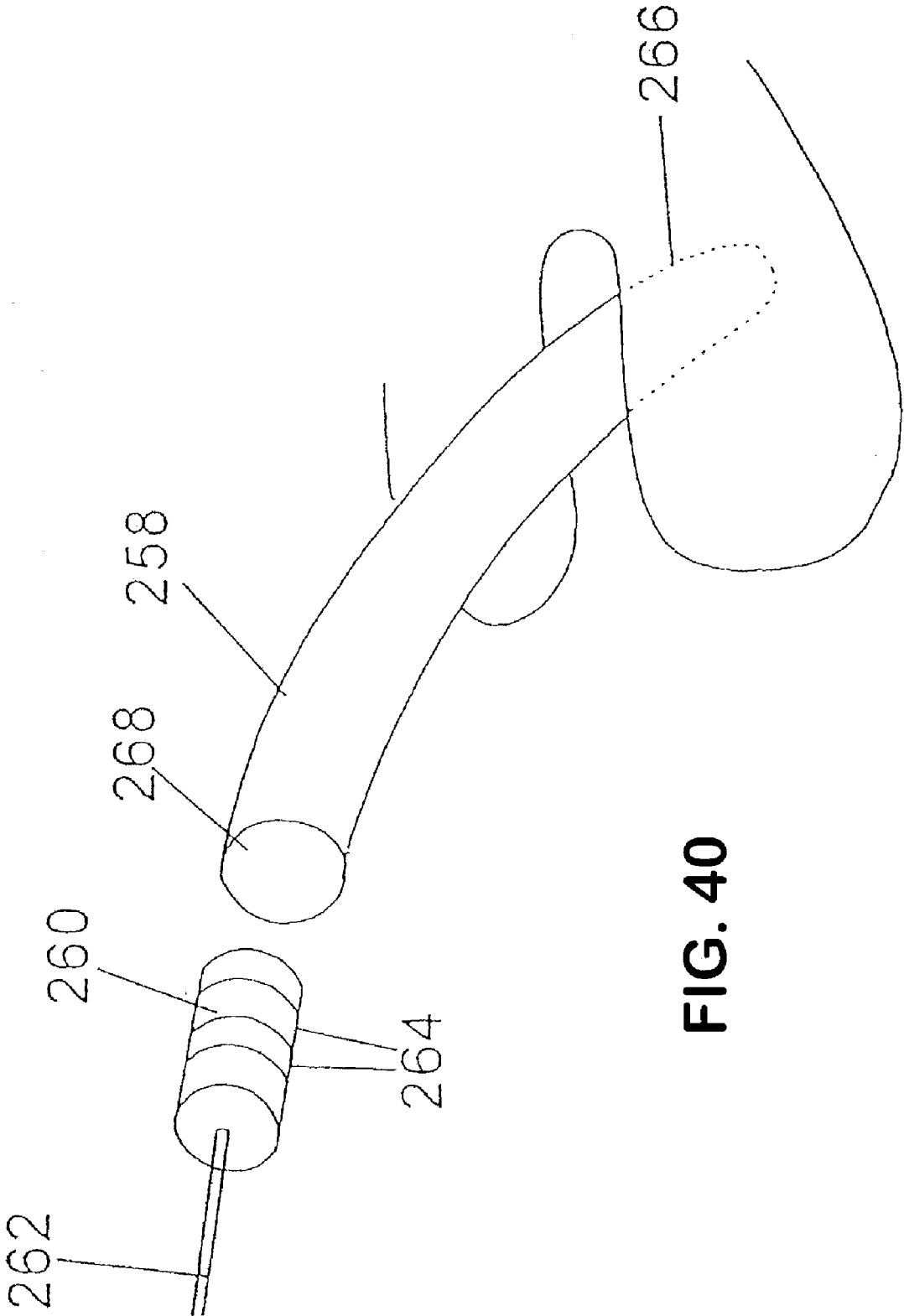

FIG. 40

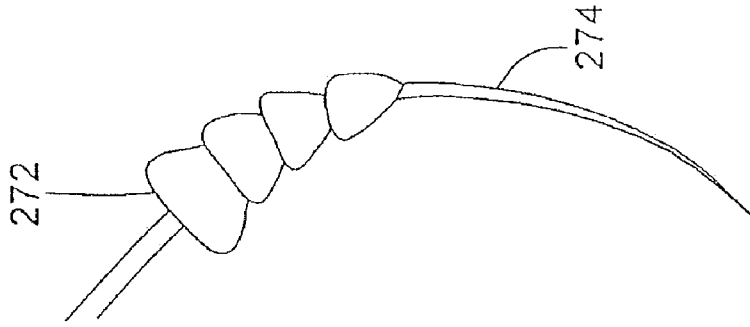

FIG. 43

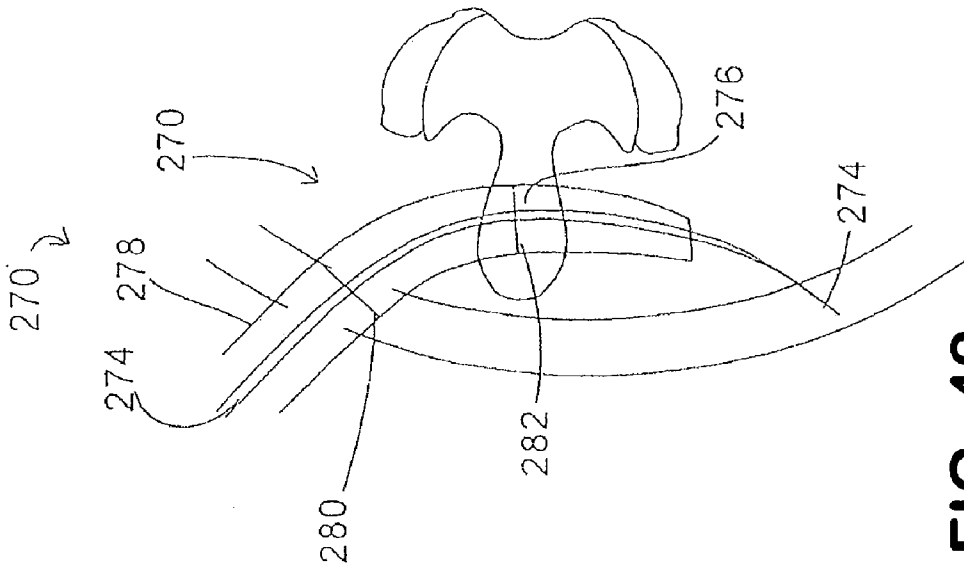

FIG. 42

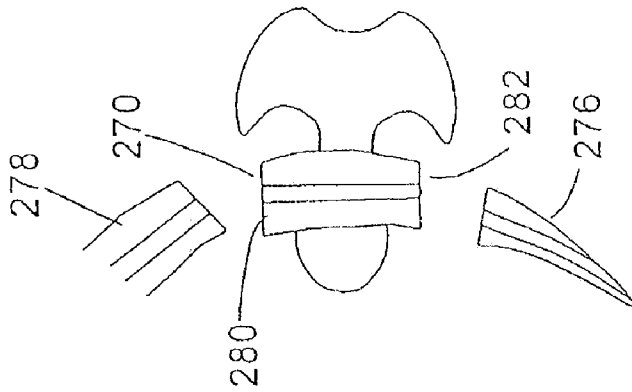

FIG. 41

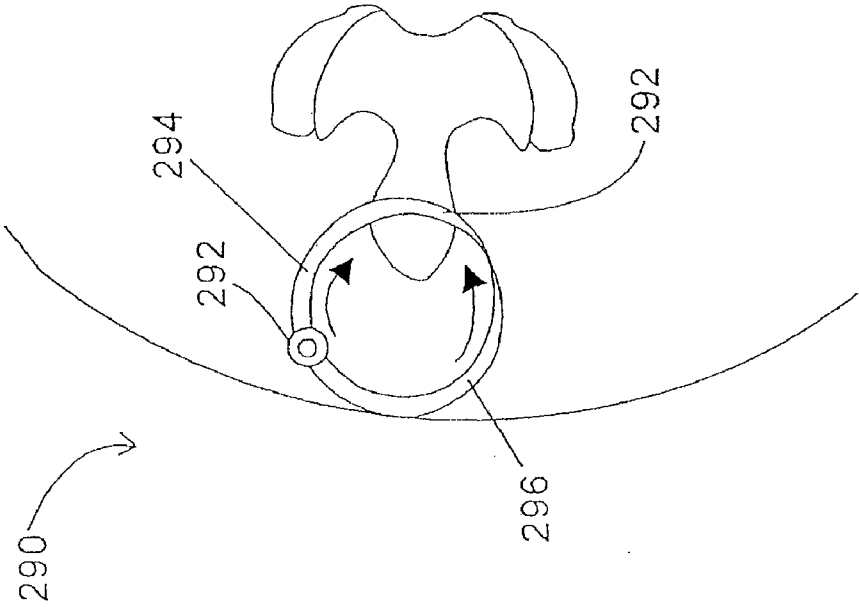

FIG. 44

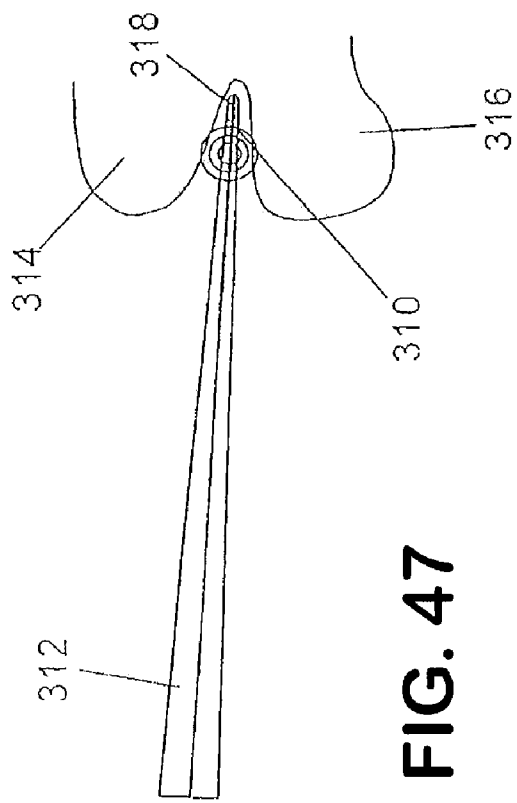

FIG. 47

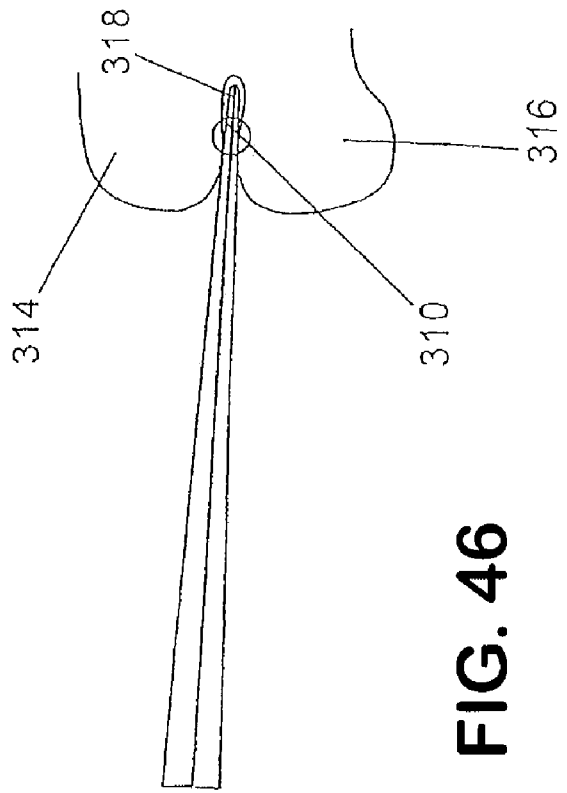

FIG. 46

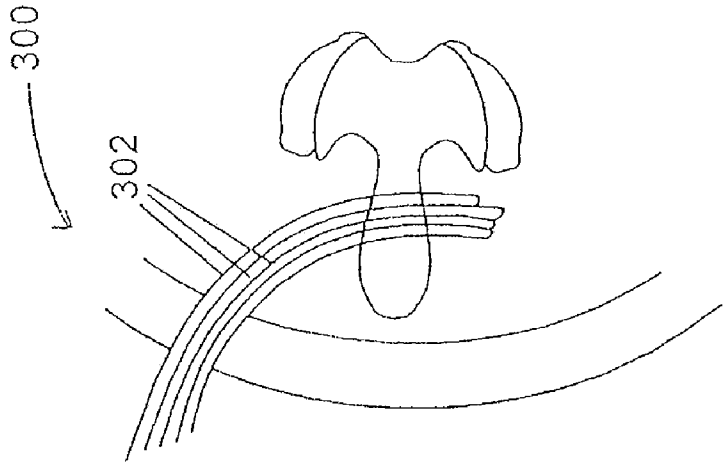

FIG. 45

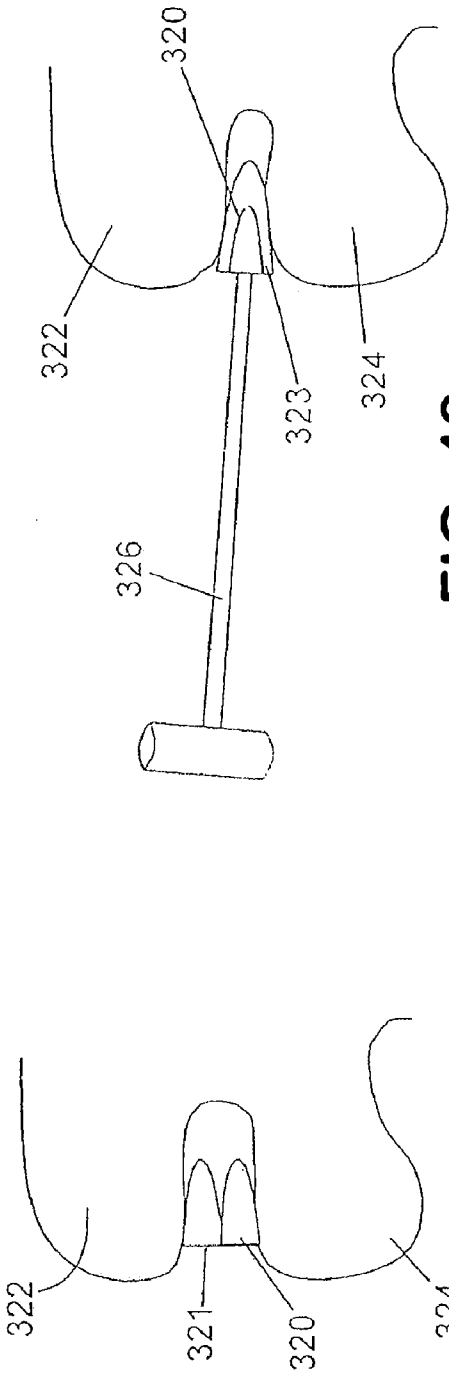

FIG. 48

FIG. 51

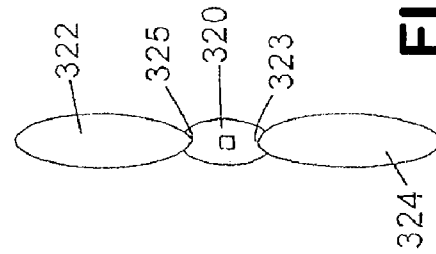

FIG. 50

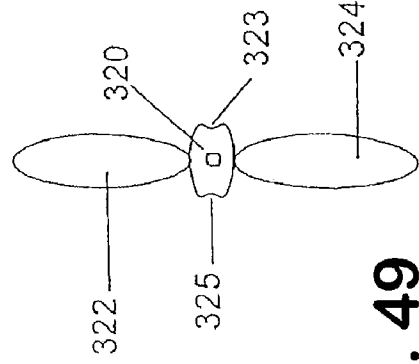

FIG. 49

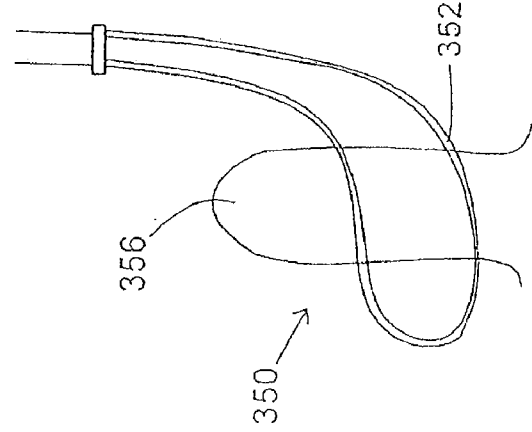

FIG. 52

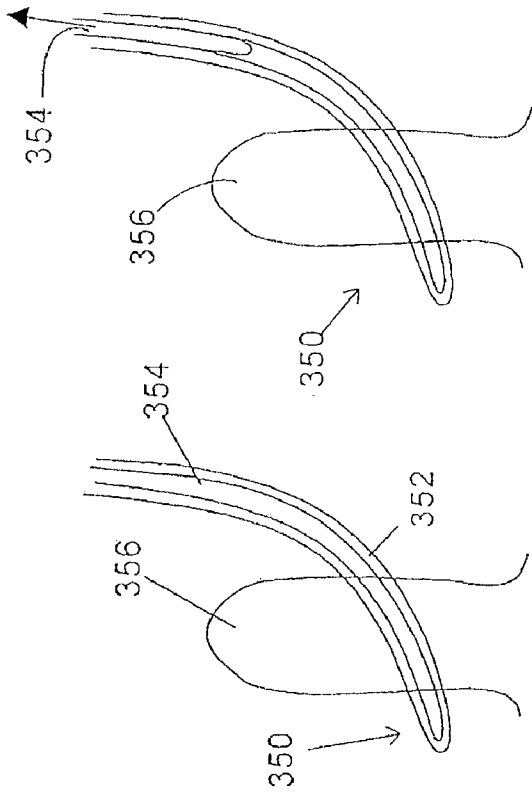

FIG. 53

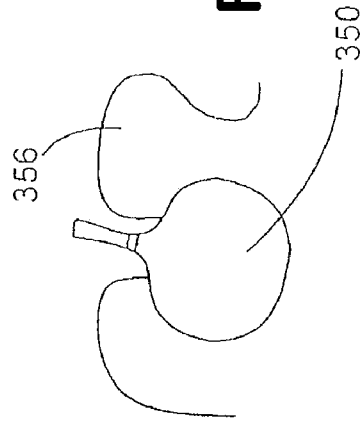

FIG. 54

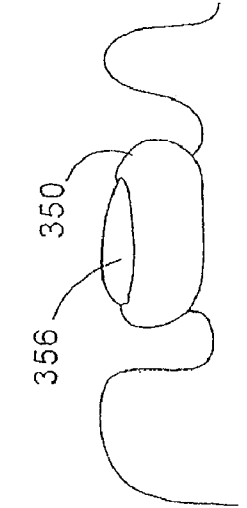

FIG. 55A

FIG. 55B

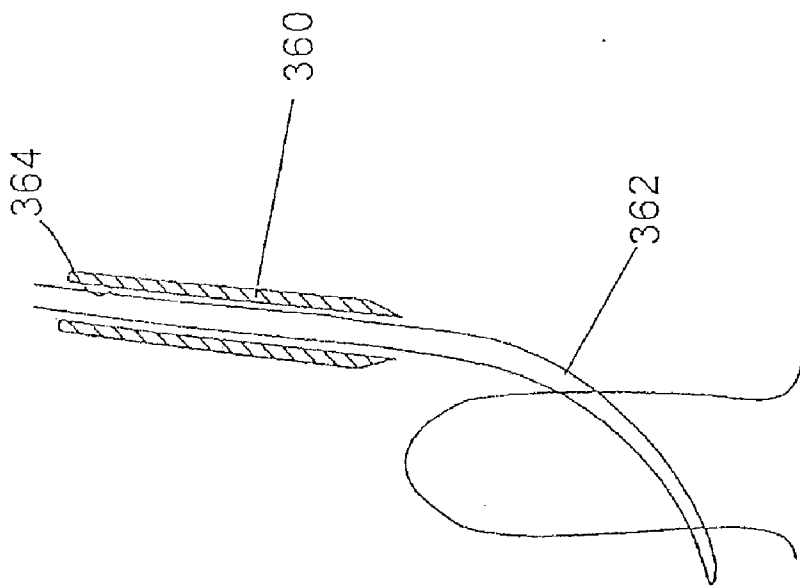

FIG. 56

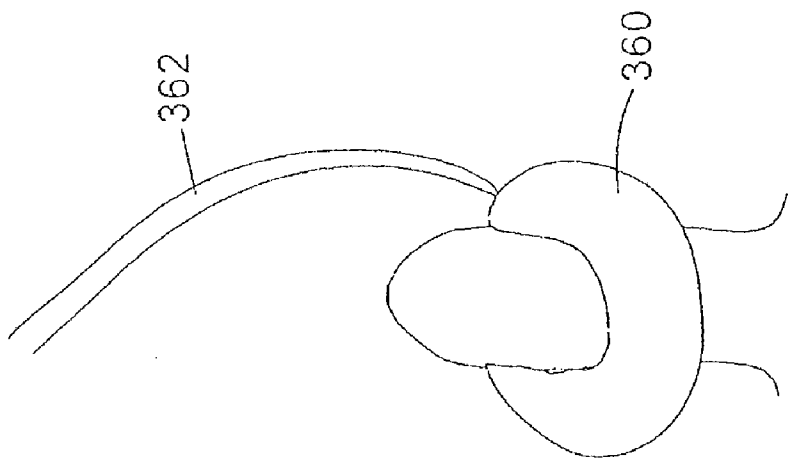

FIG. 57

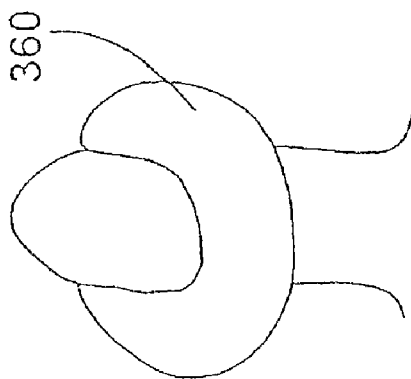

FIG. 58

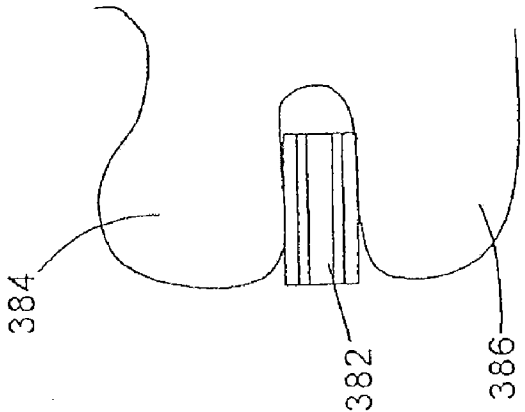

FIG. 59

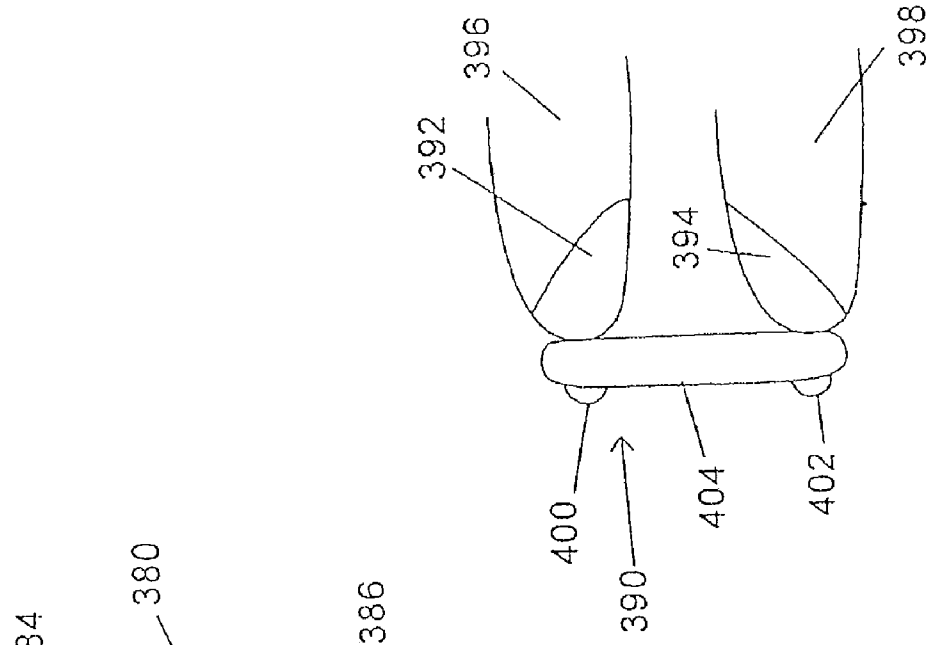

FIG. 60

FIG. 61

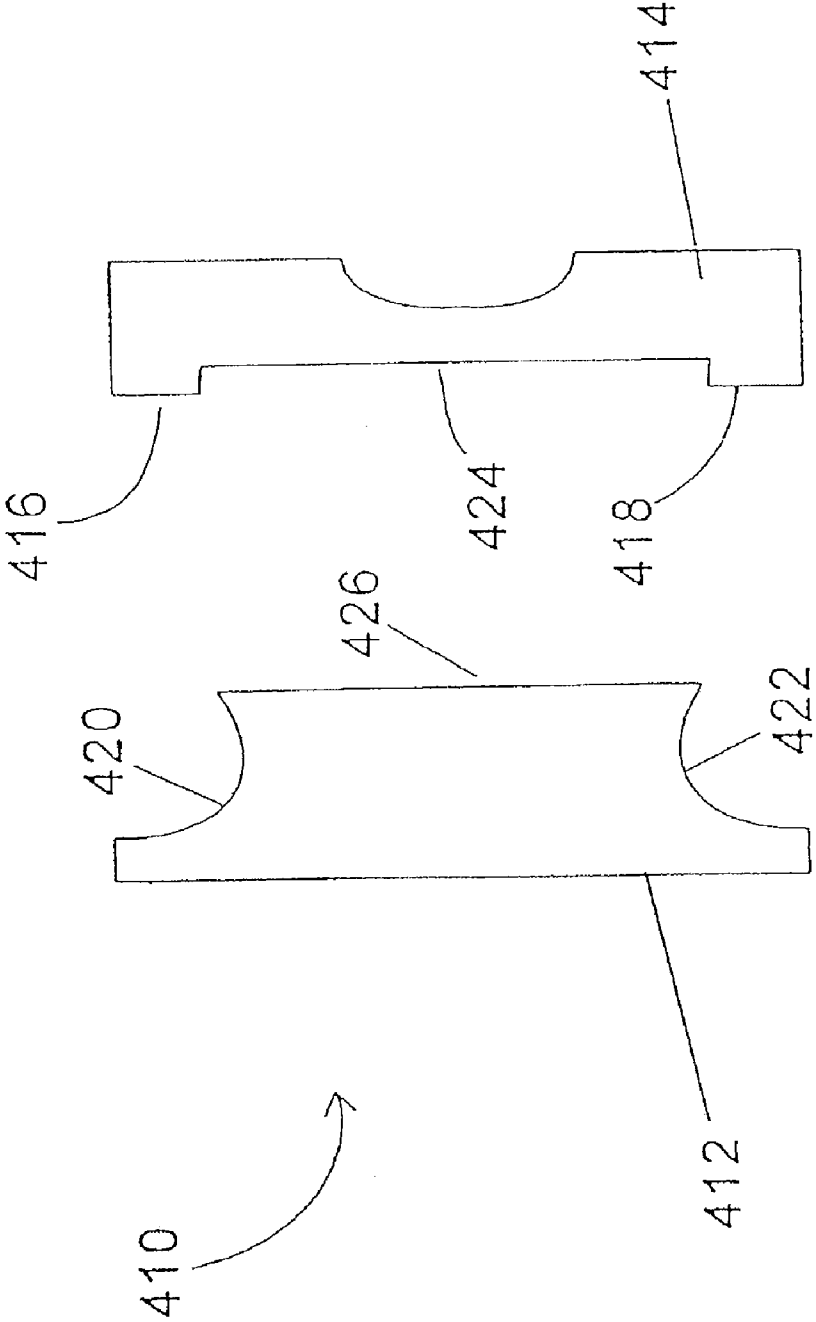

FIG. 62

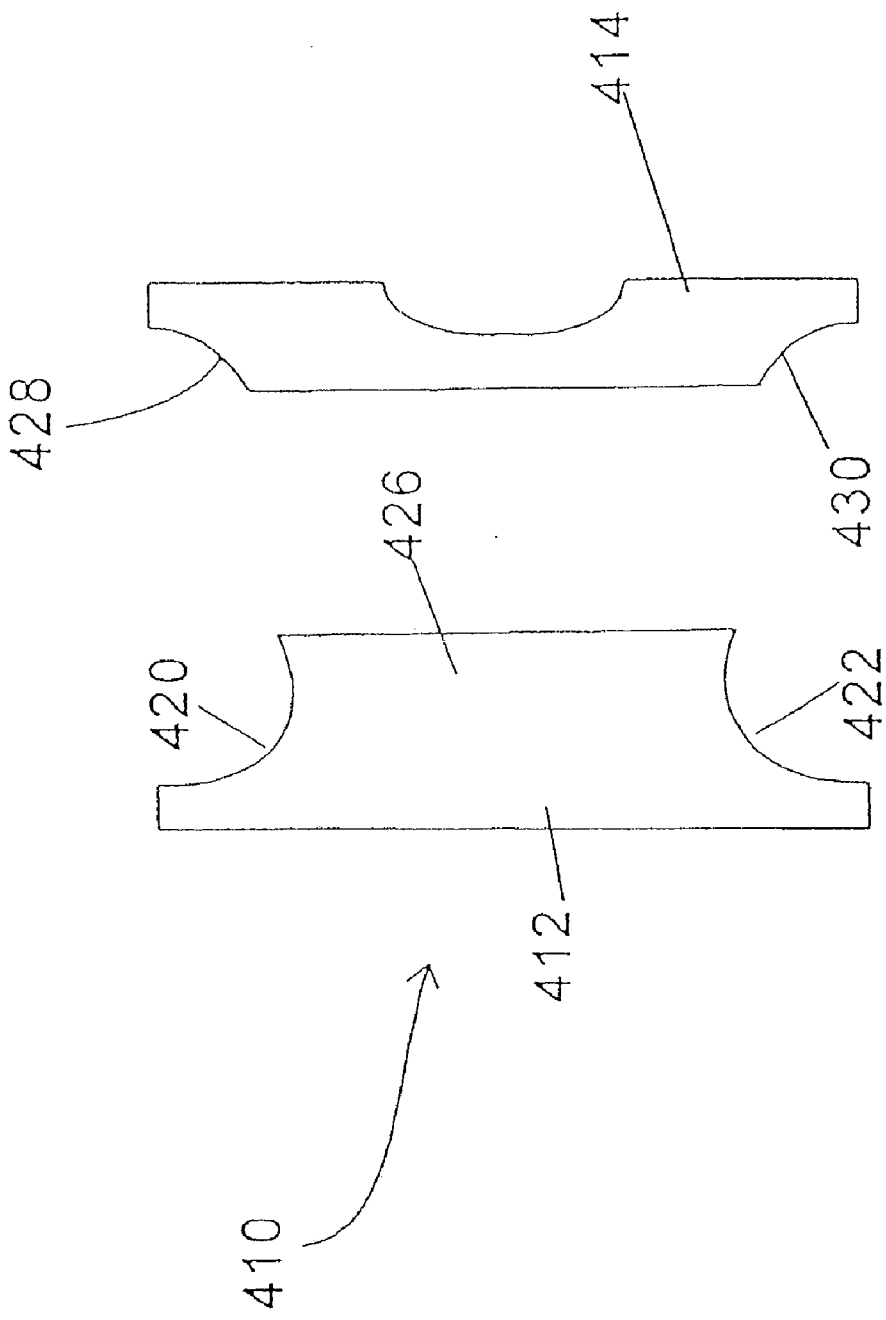

FIG. 63

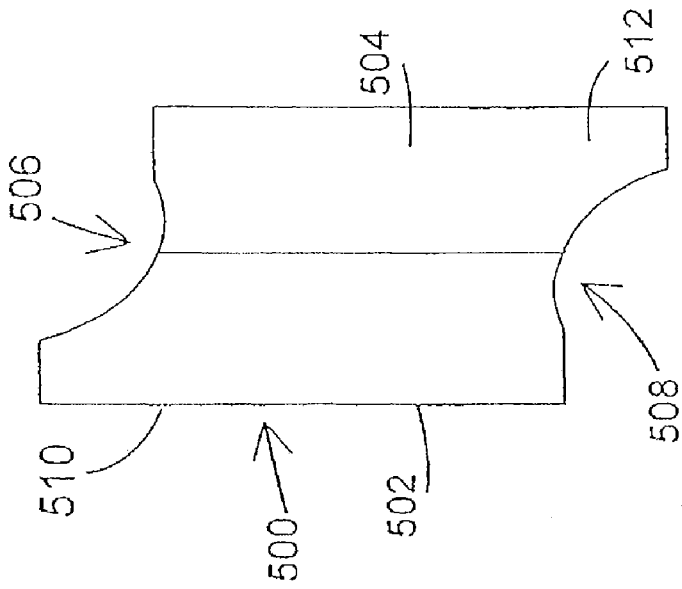

FIG. 64

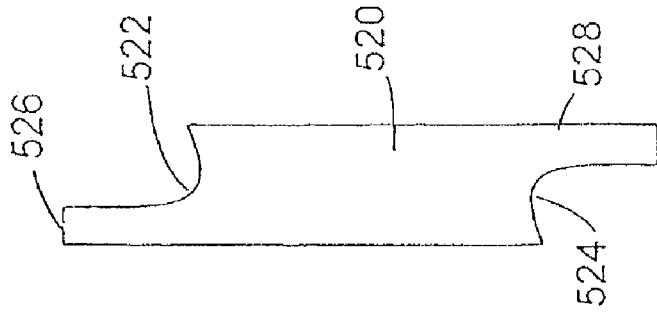

FIG. 65

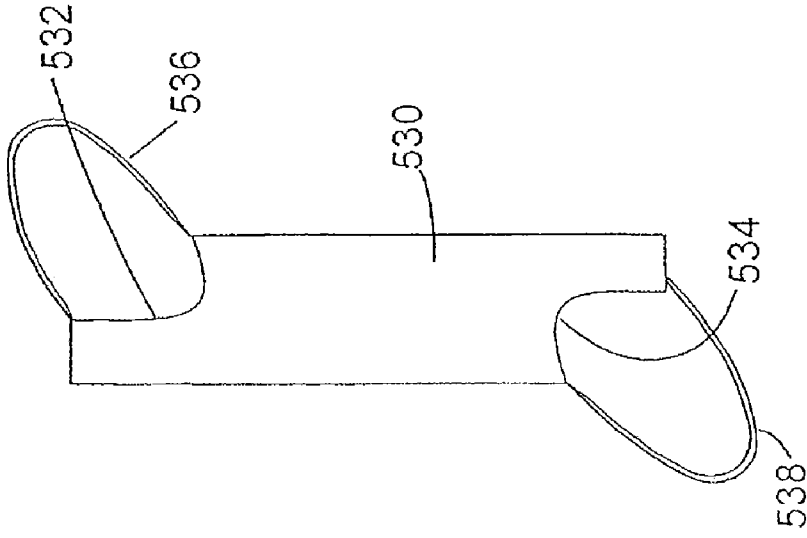

FIG. 66

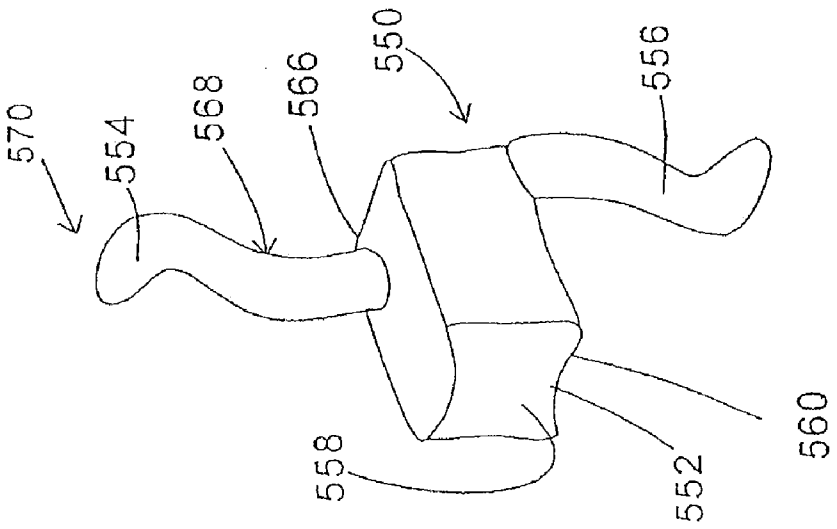

FIG. 67

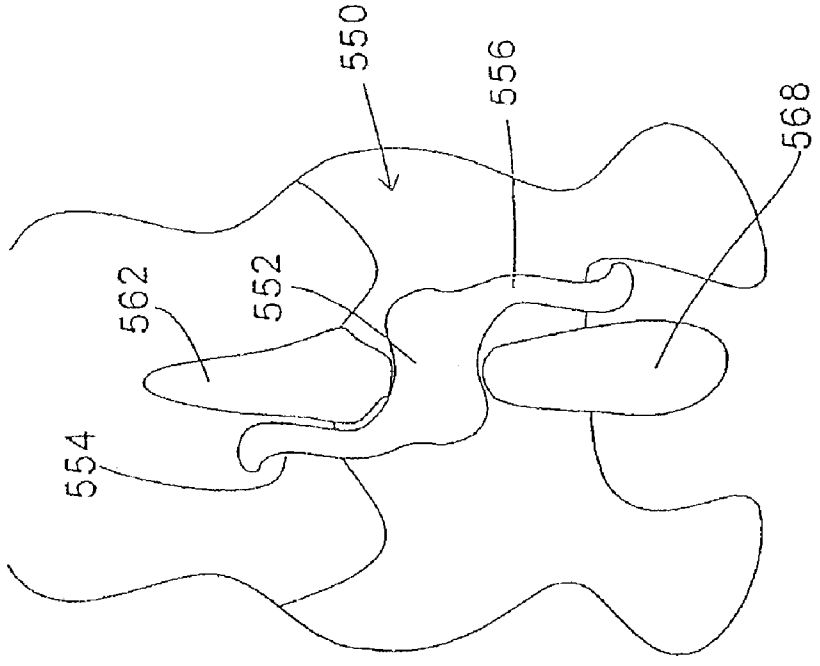

FIG. 68

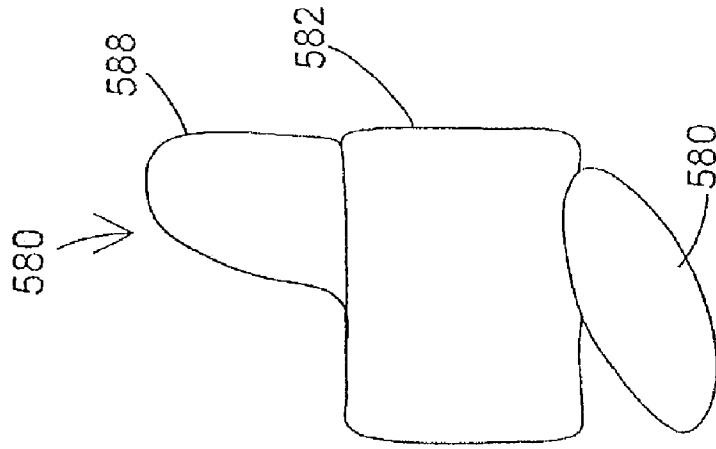

FIG. 71

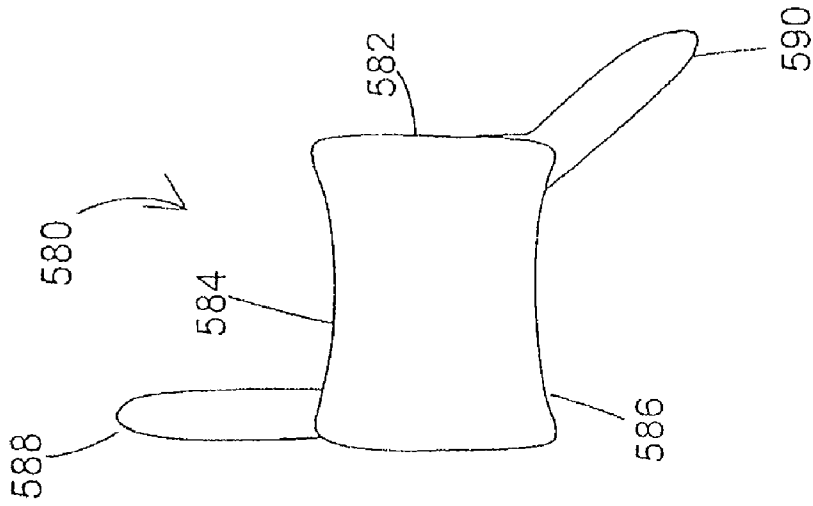

FIG. 70

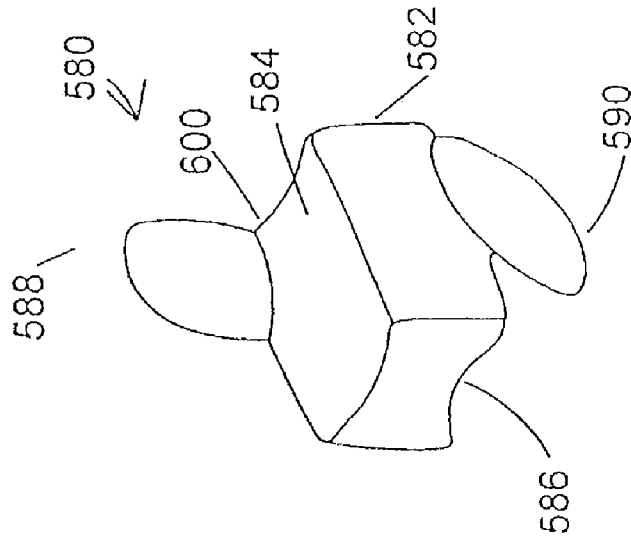

FIG. 69

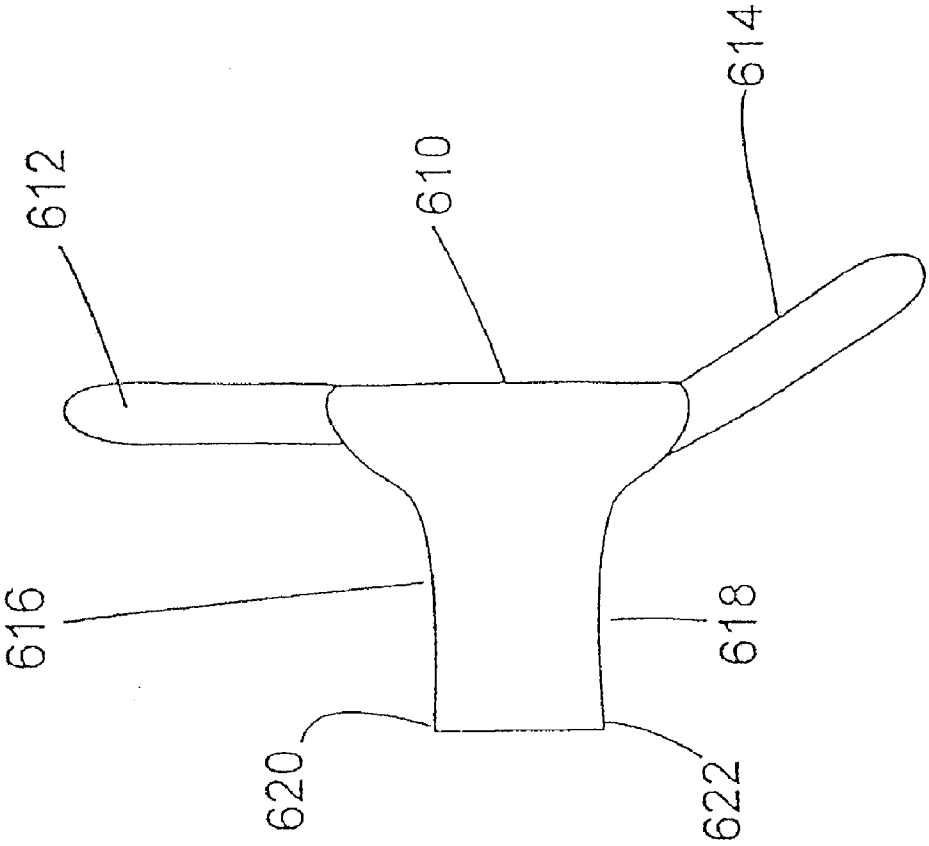

FIG. 71A

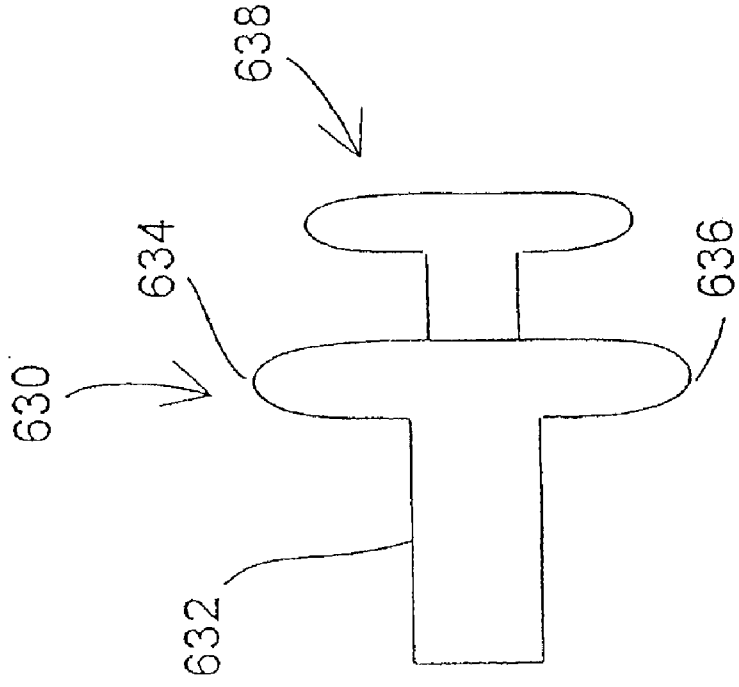

FIG. 72

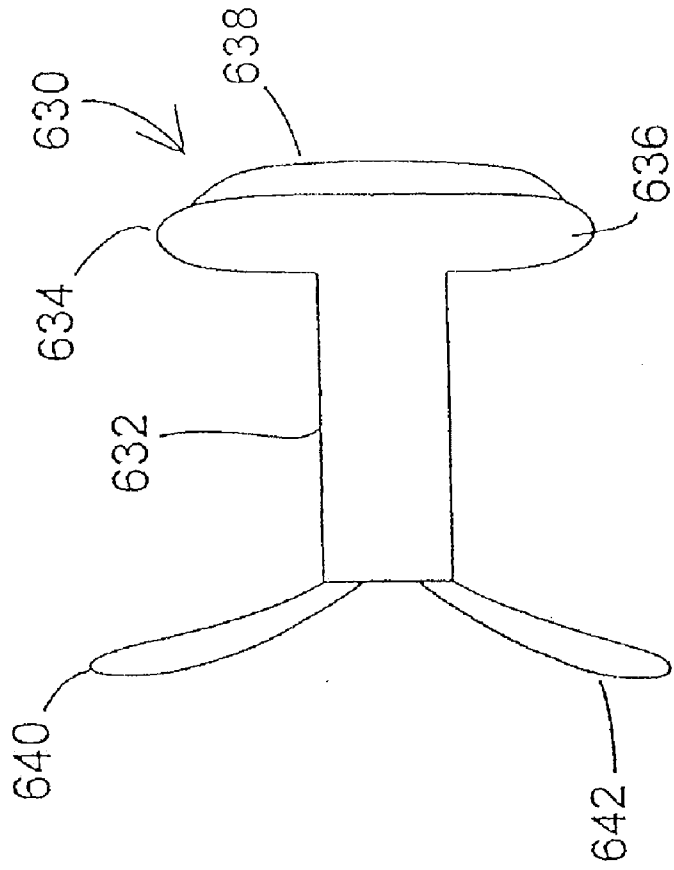

FIG. 73

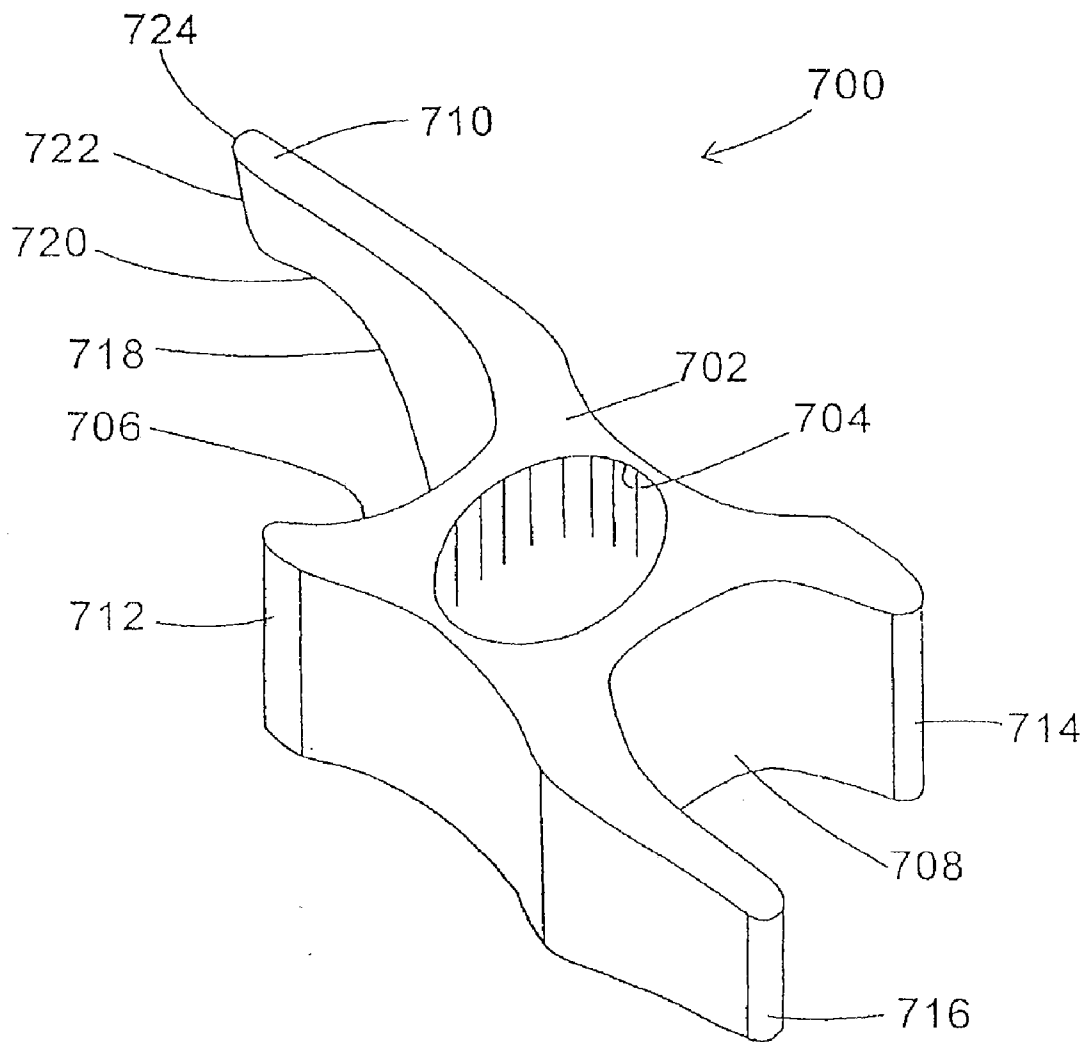

FIG. 74

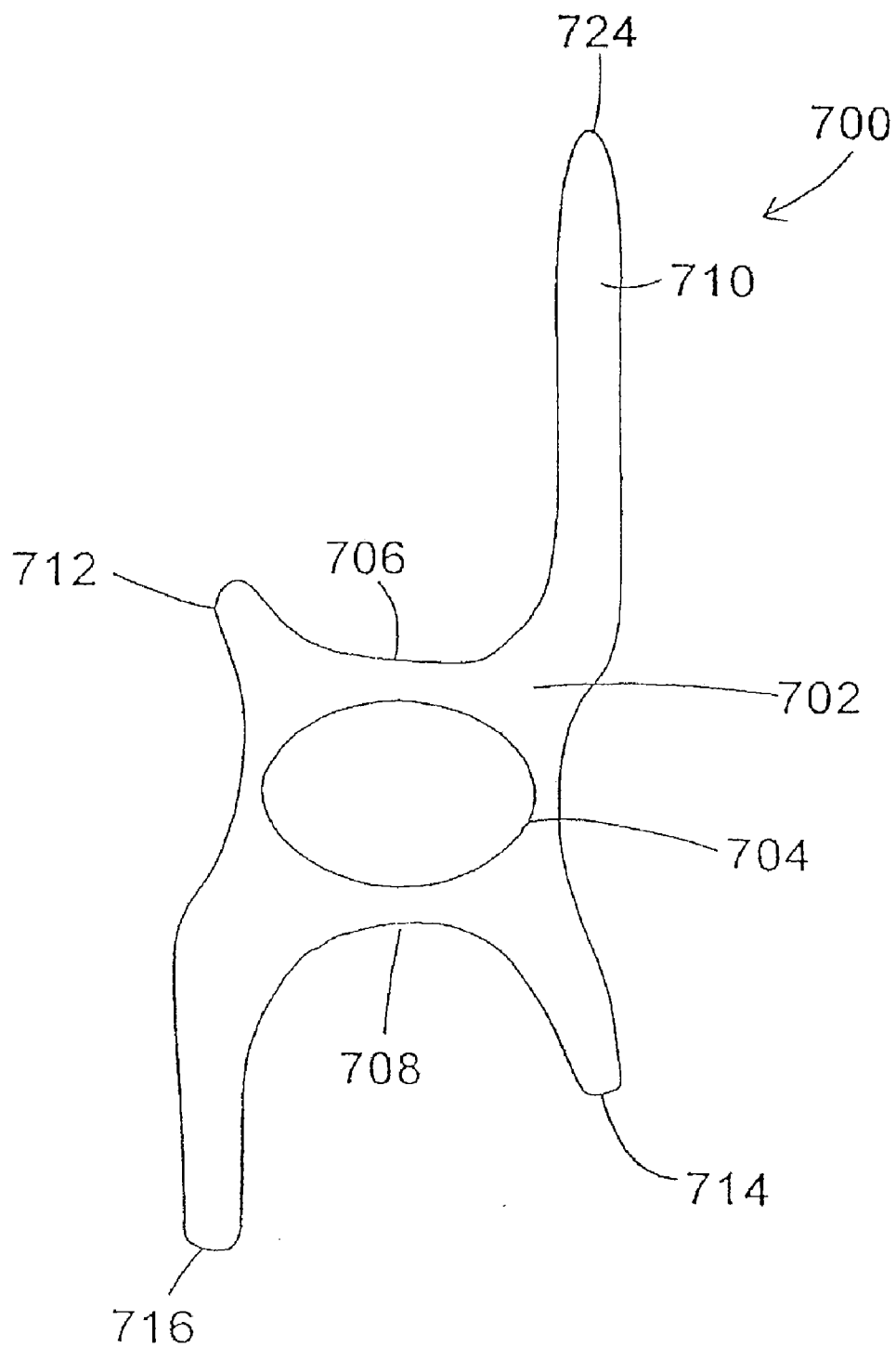

FIG. 75

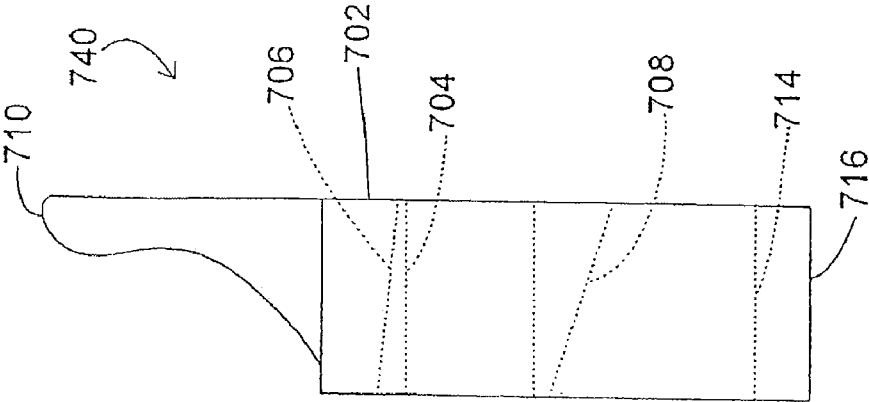

FIG. 77

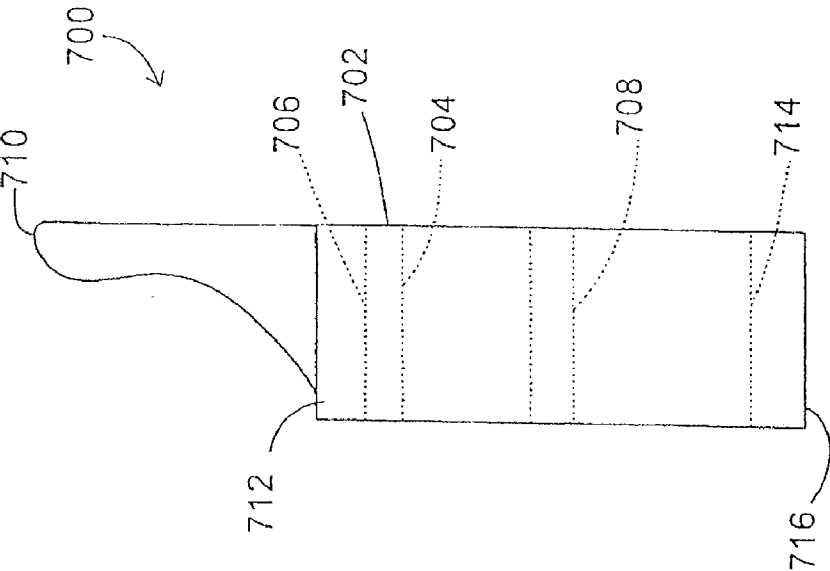

FIG. 76

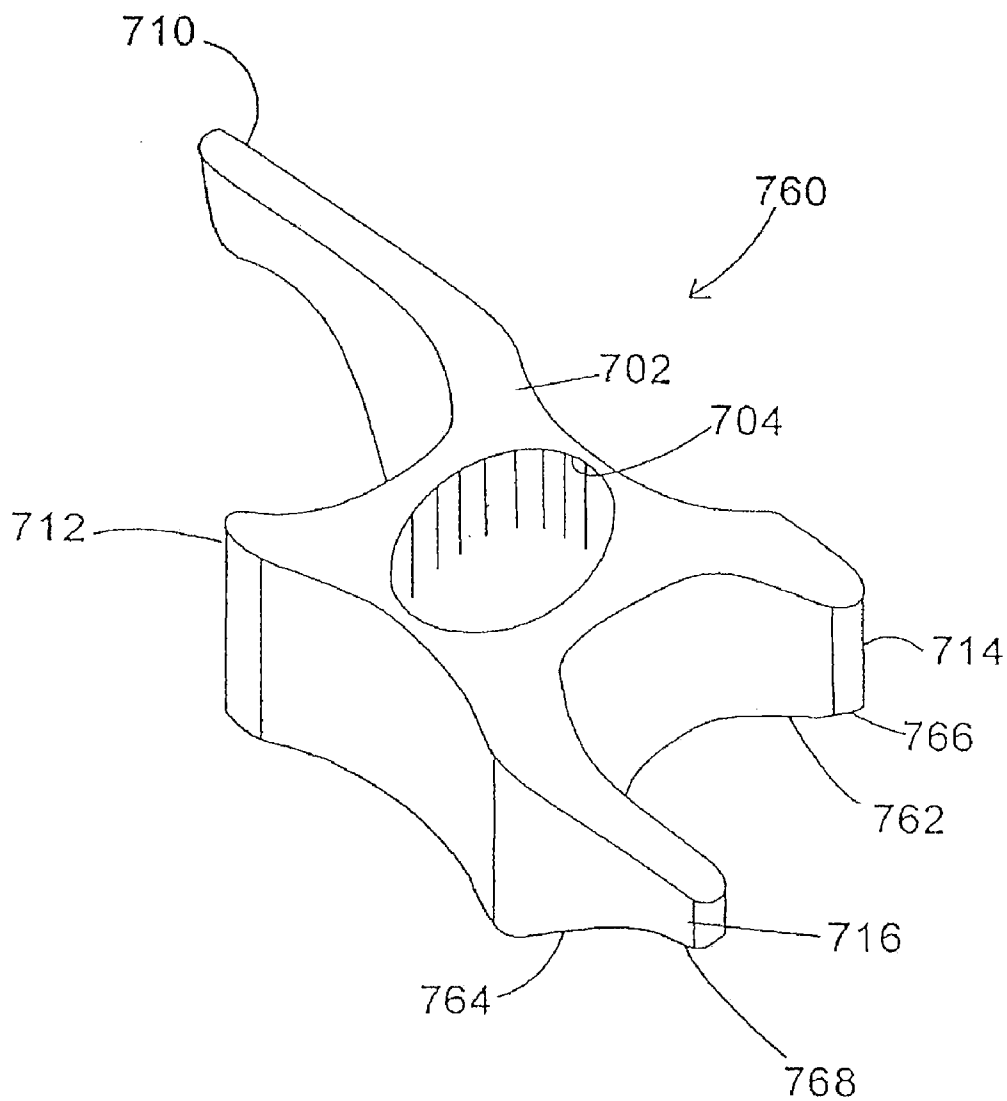

FIG. 78

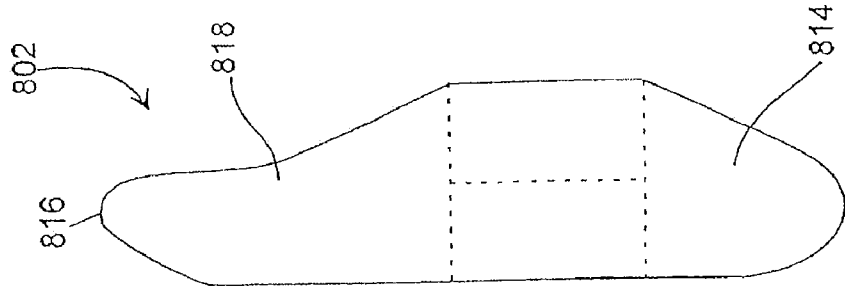

FIG. 81

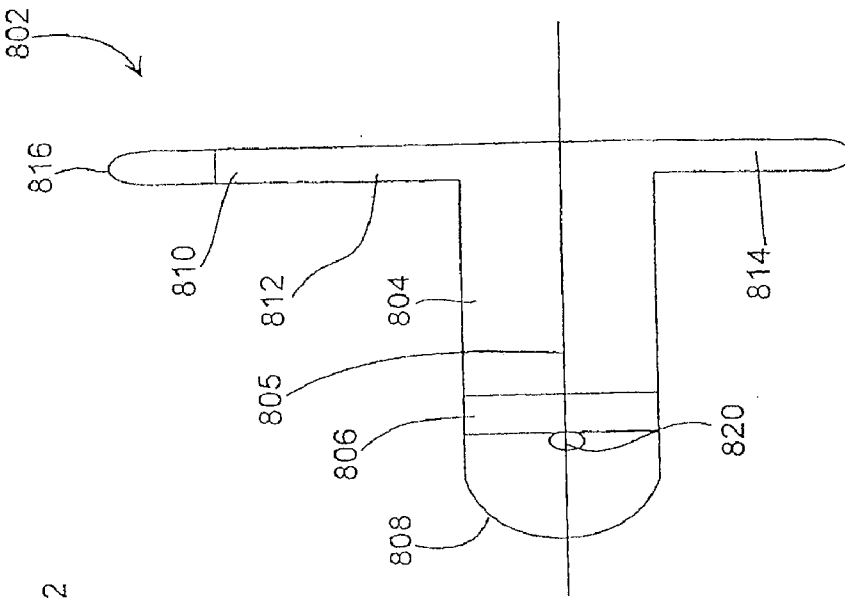

FIG. 80

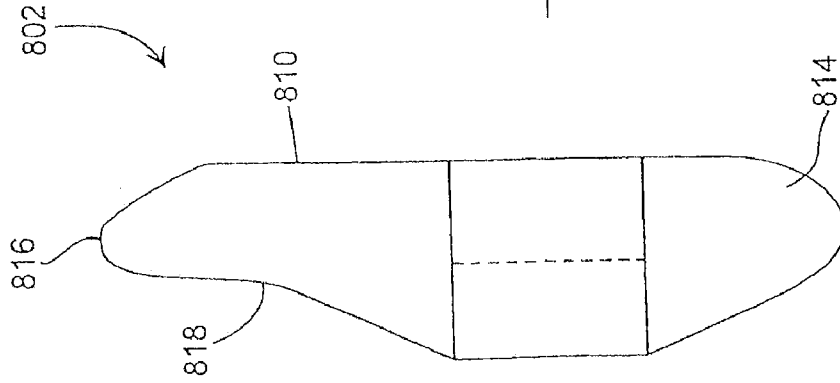

FIG. 79

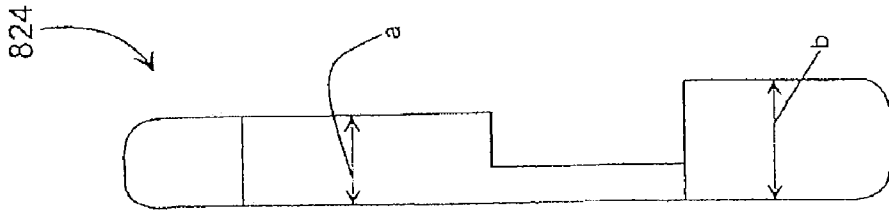

FIG. 83A

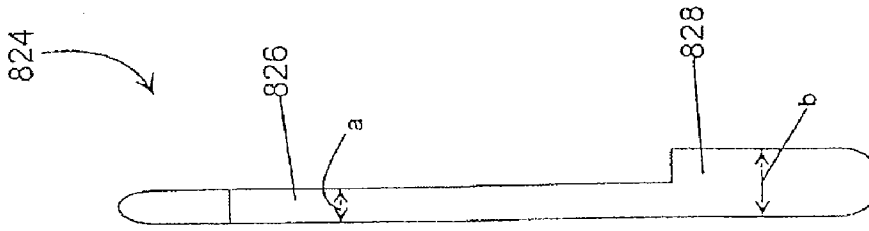

FIG. 83

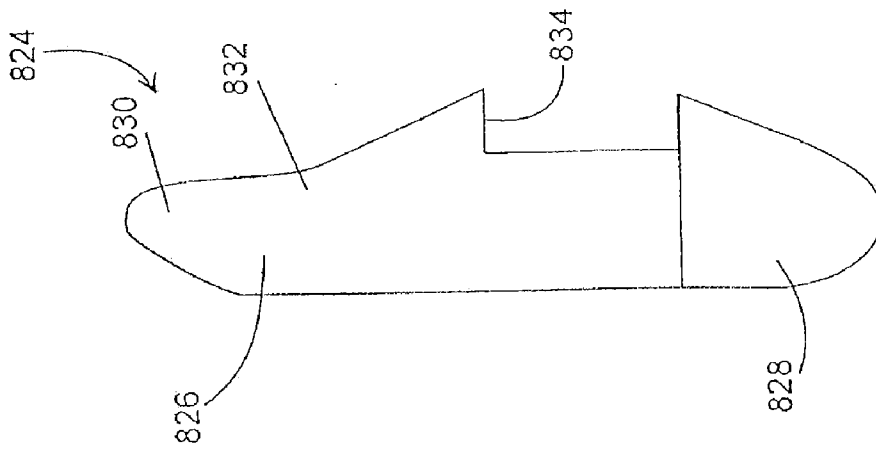

FIG. 82

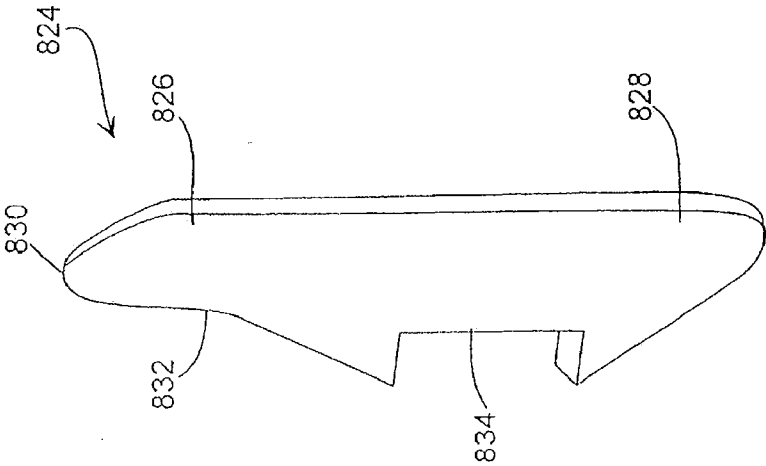

FIG. 84

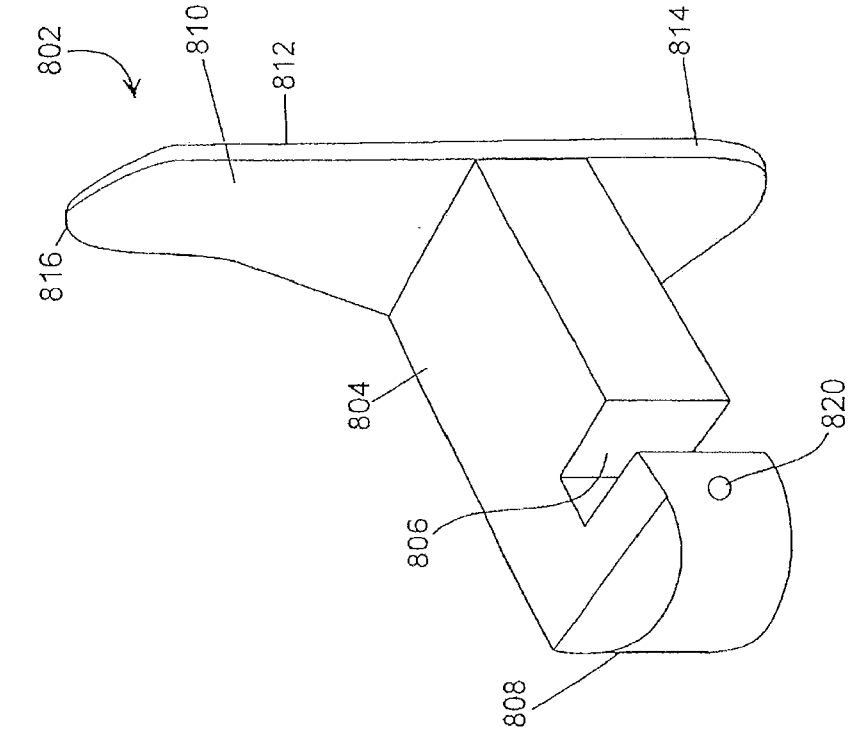

FIG. 85

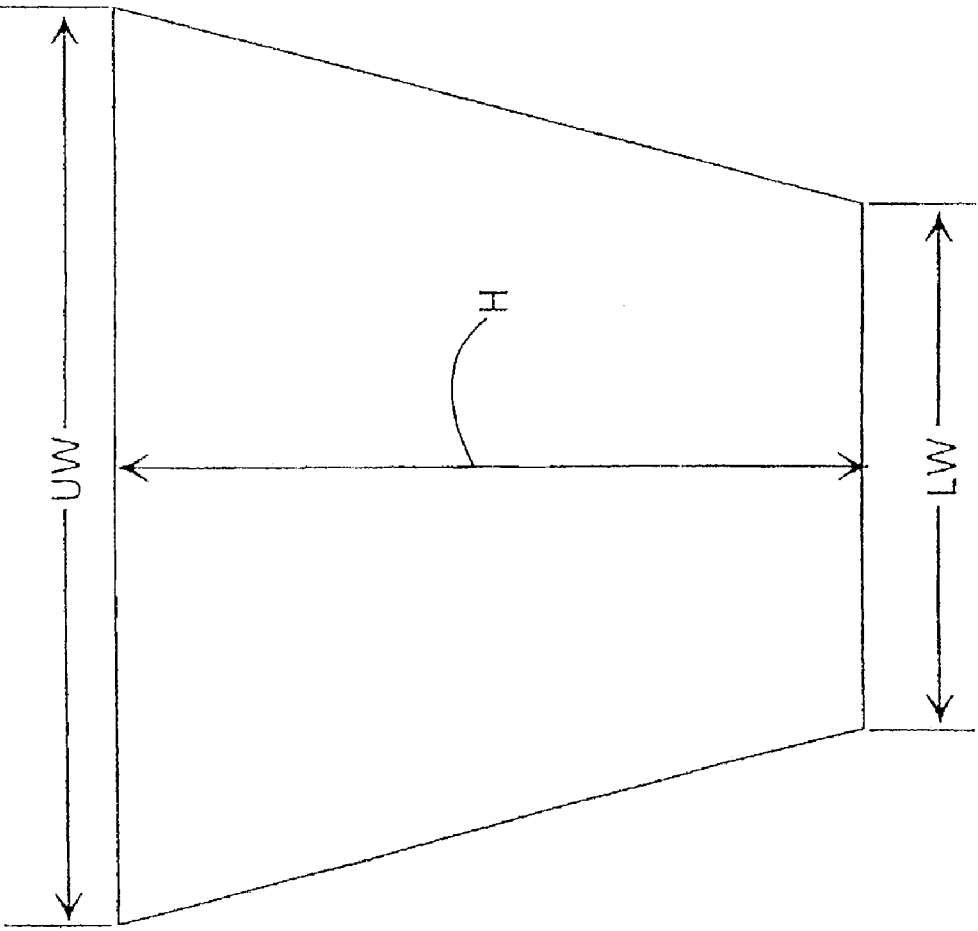

FIG. 87

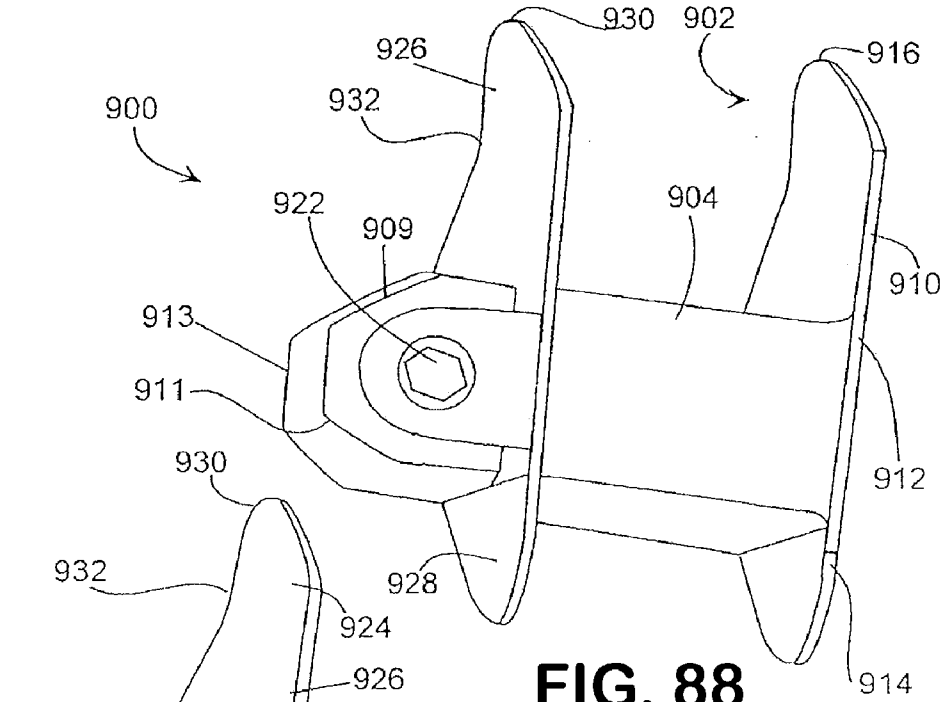

FIG. 88

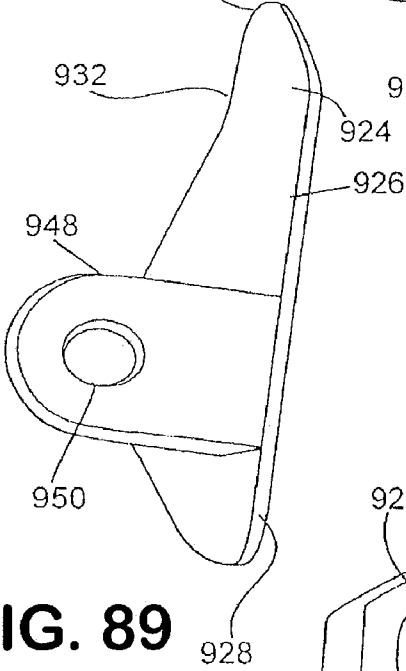

FIG. 89

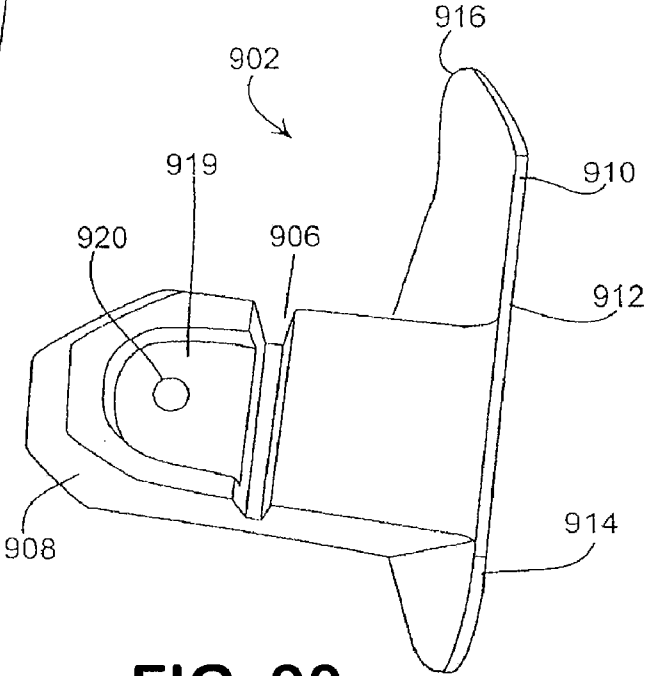

FIG. 90

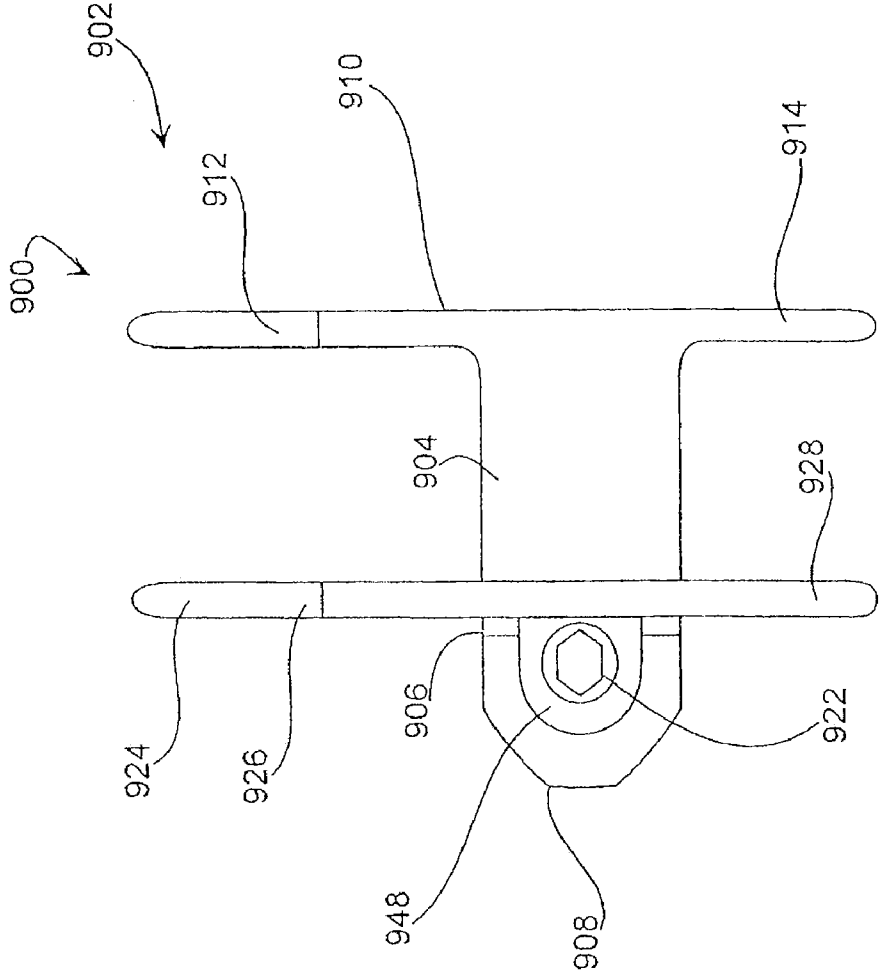

FIG. 91

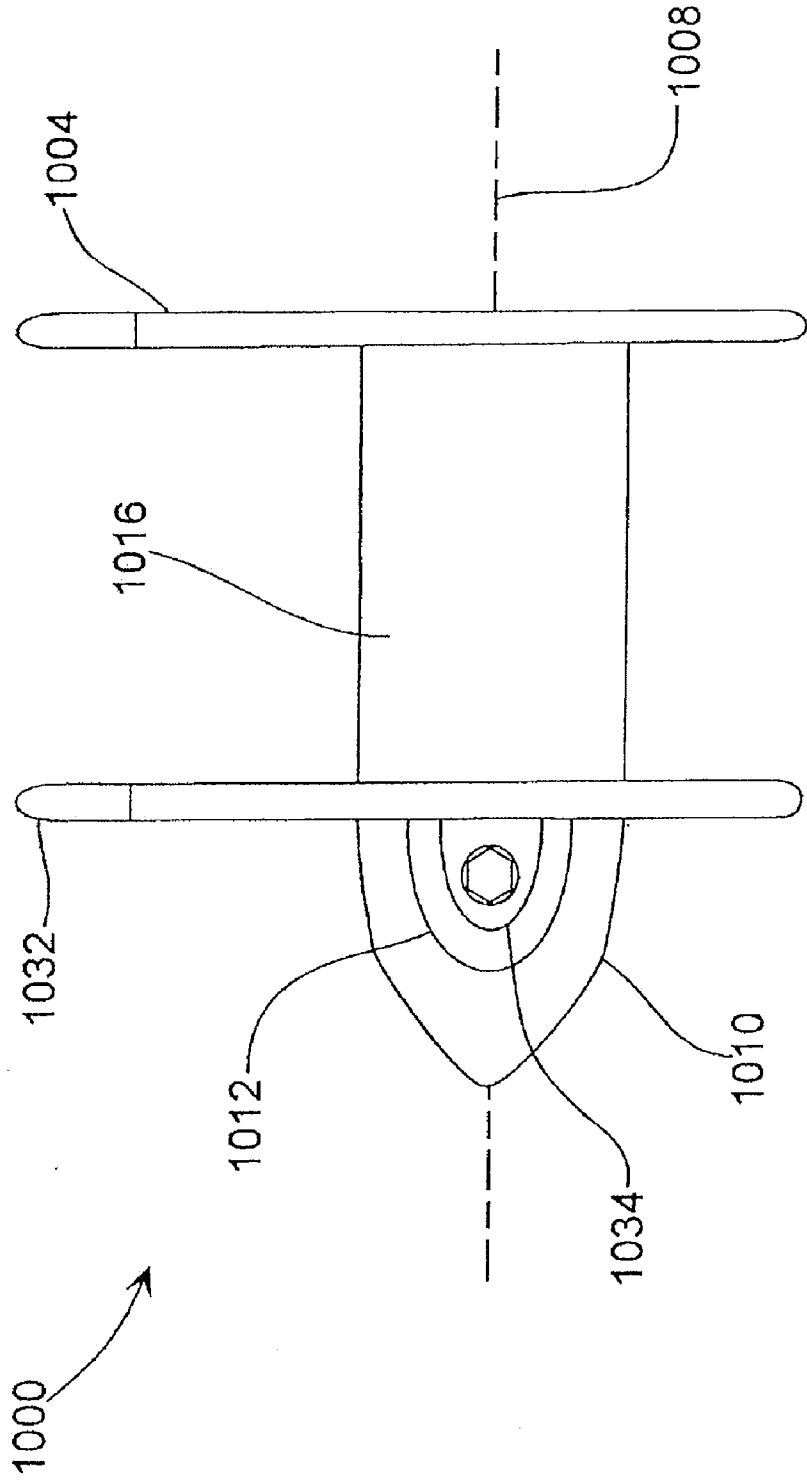

FIG. 92

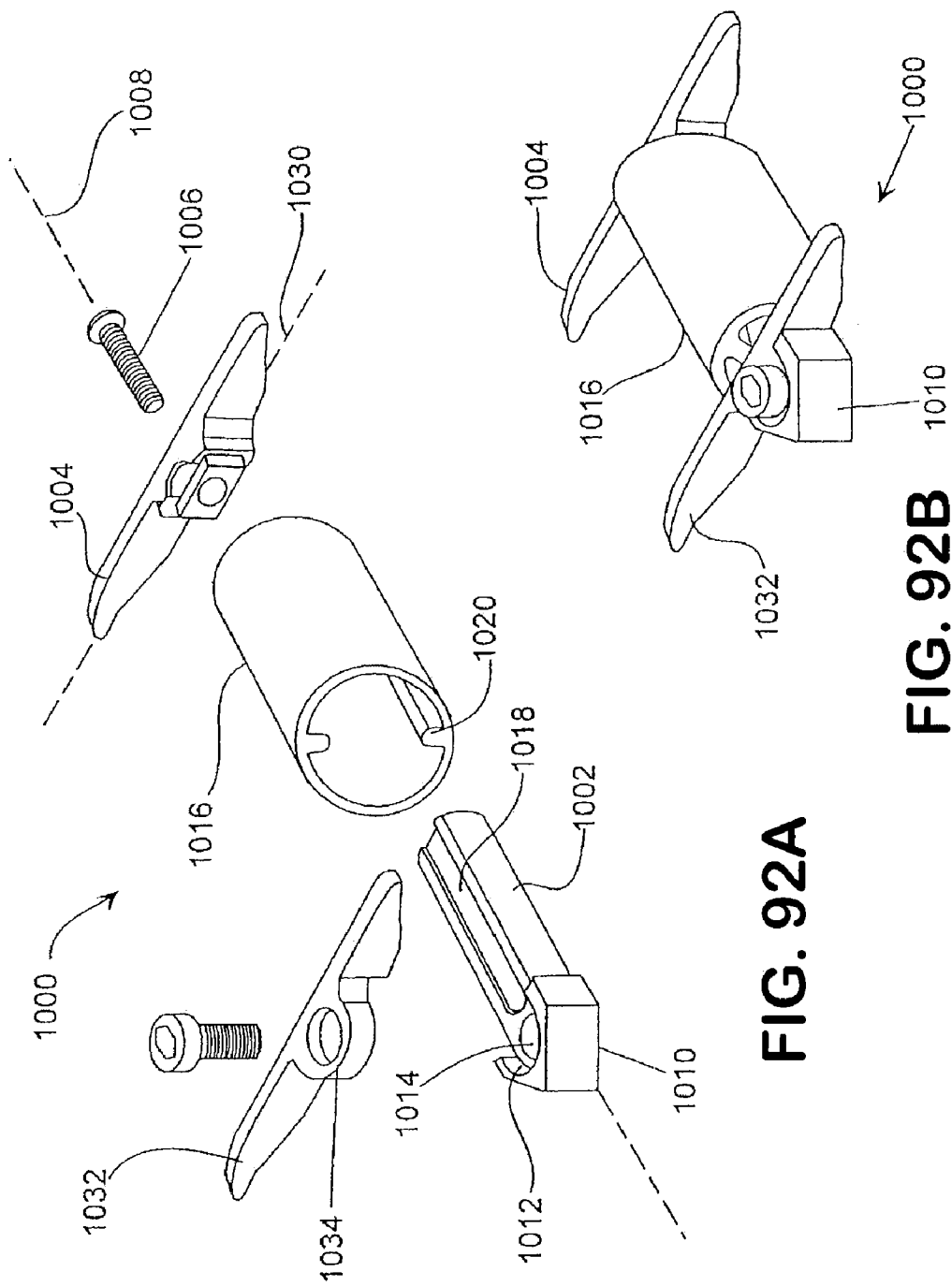

FIG. 92A

FIG. 92B

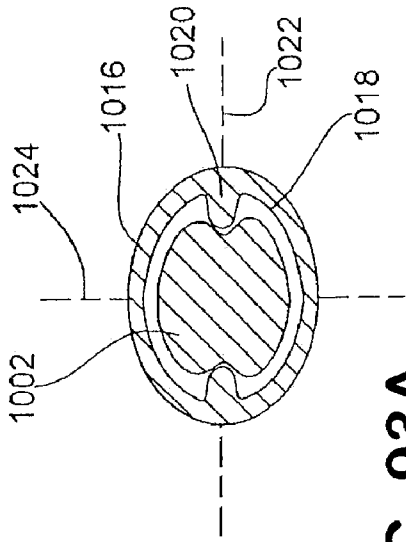

FIG. 93A

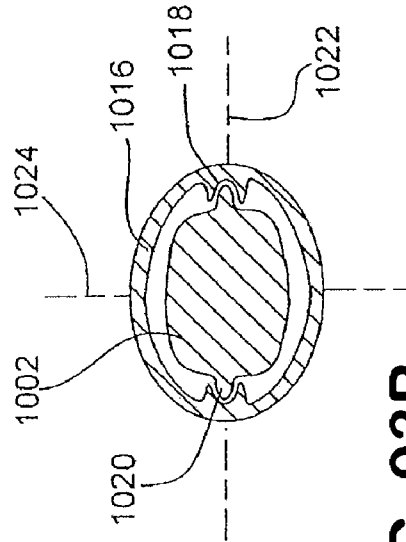

FIG. 93B

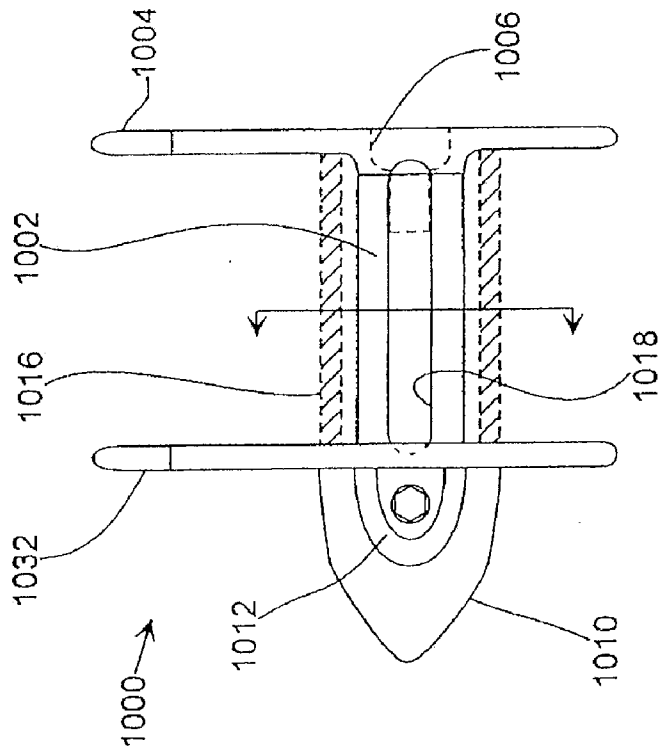

FIG. 93

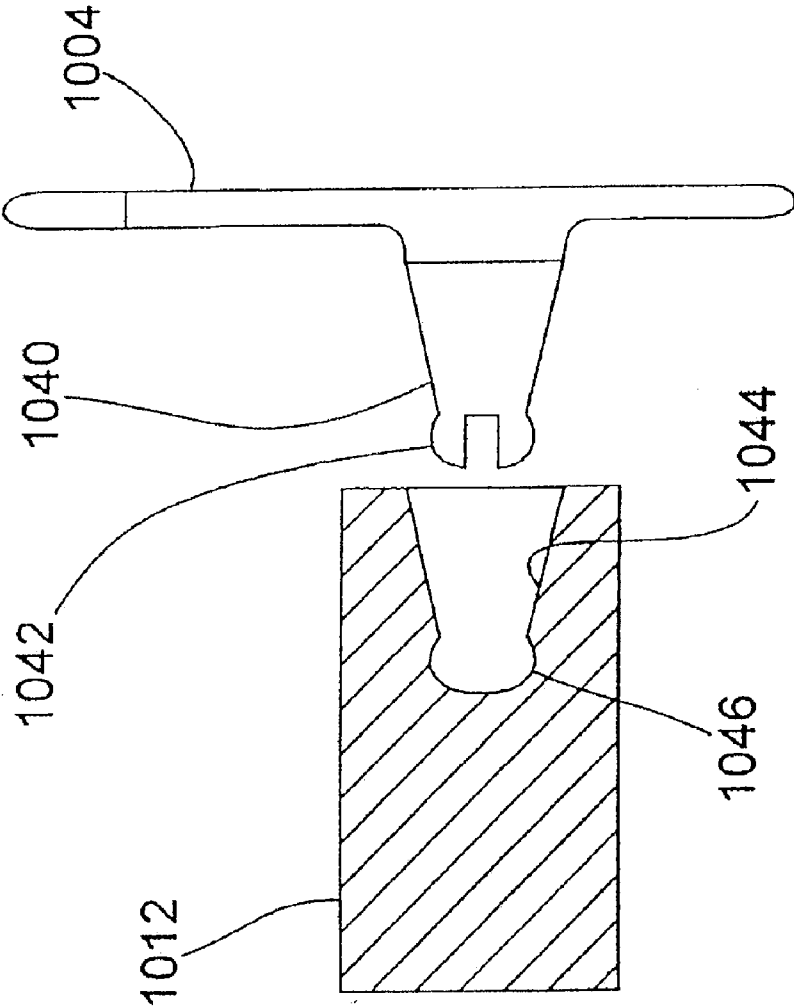

FIG. 93C

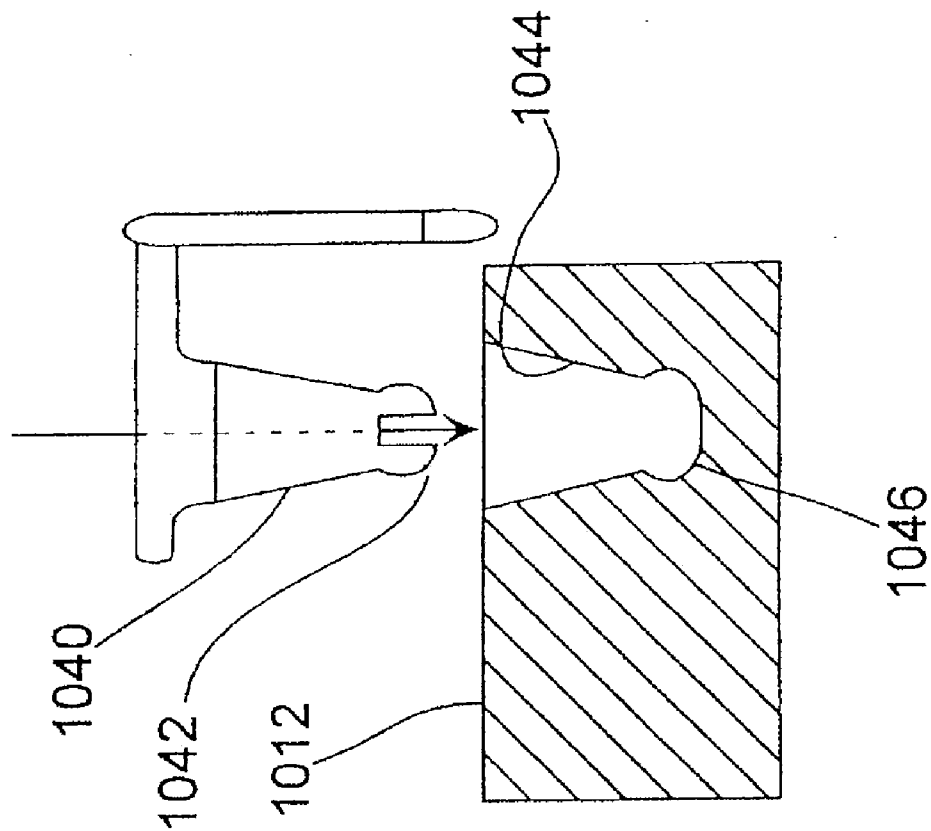

FIG. 93D

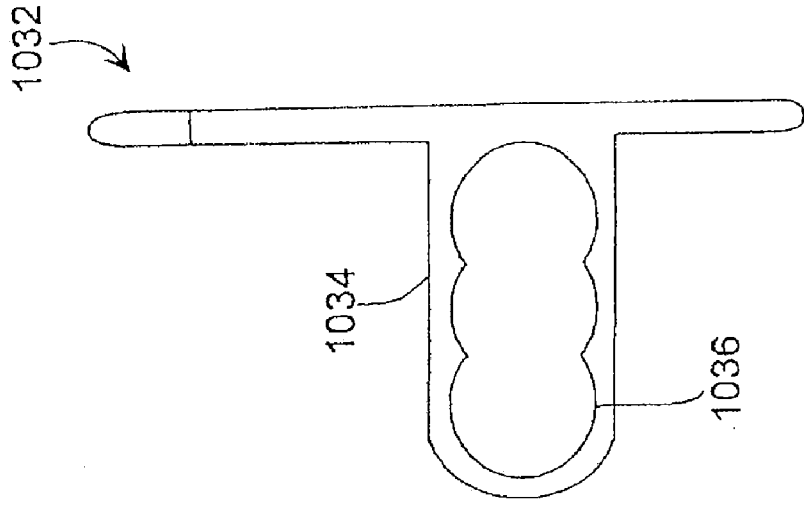

FIG. 94A

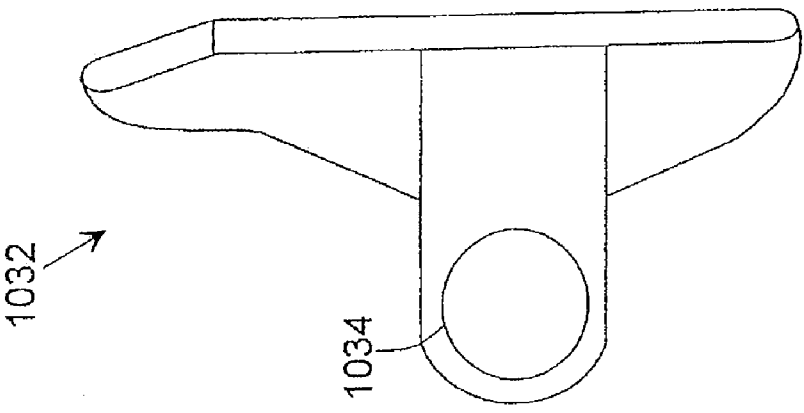

FIG. 94B

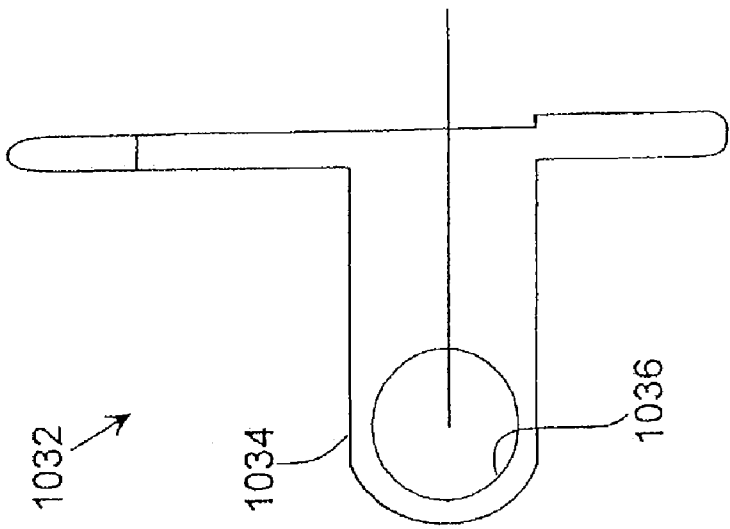

FIG. 94

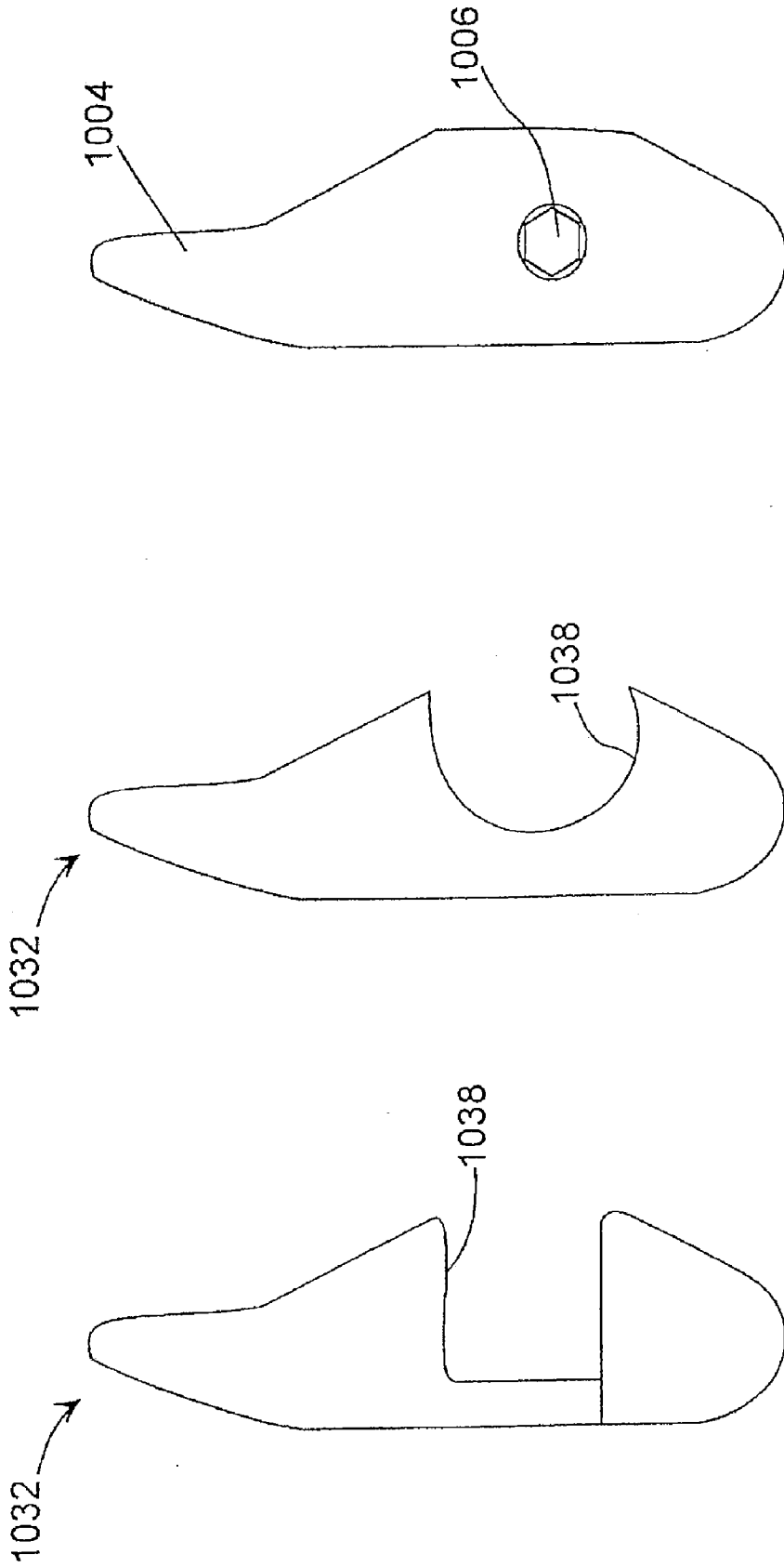

FIG. 96

FIG. 95A

FIG. 95

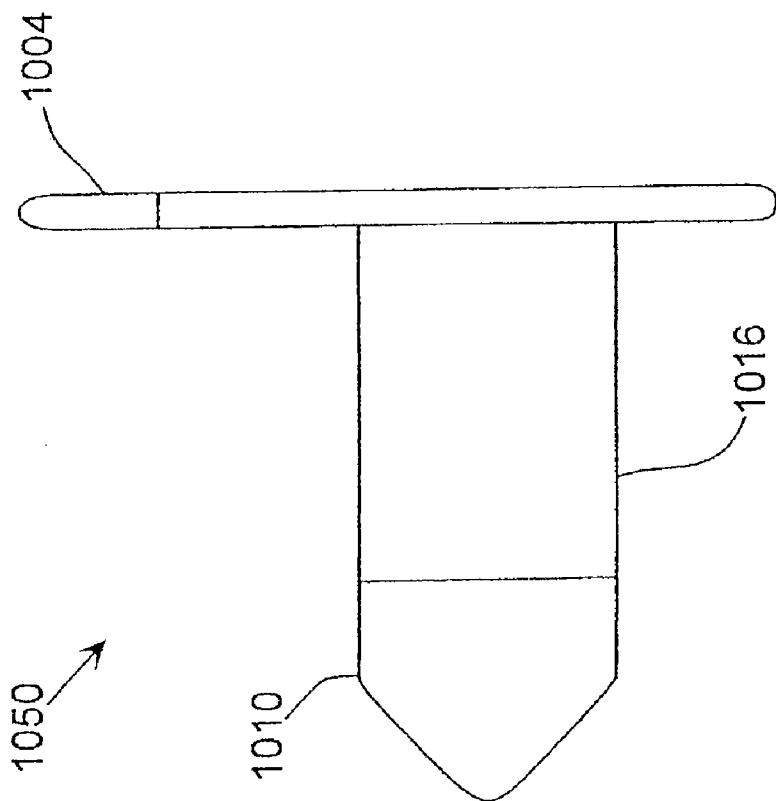

FIG. 97

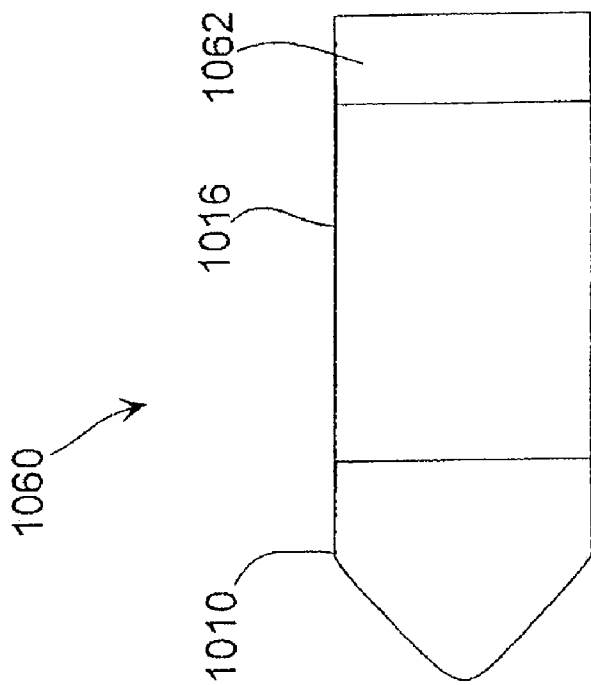

FIG. 98

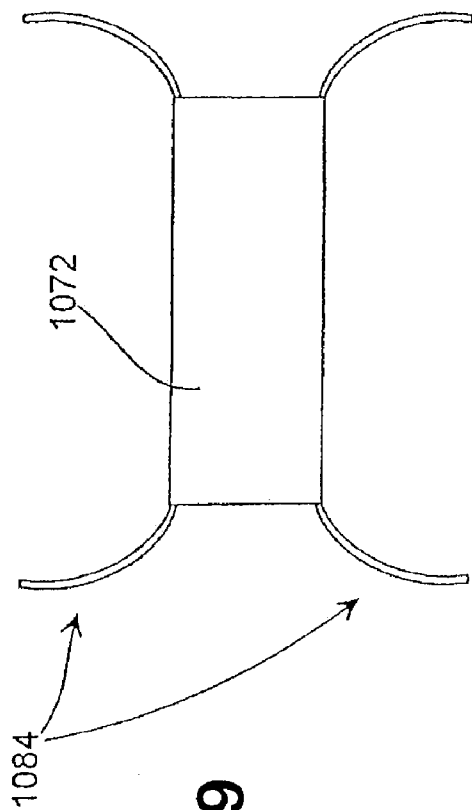

FIG. 99

1070

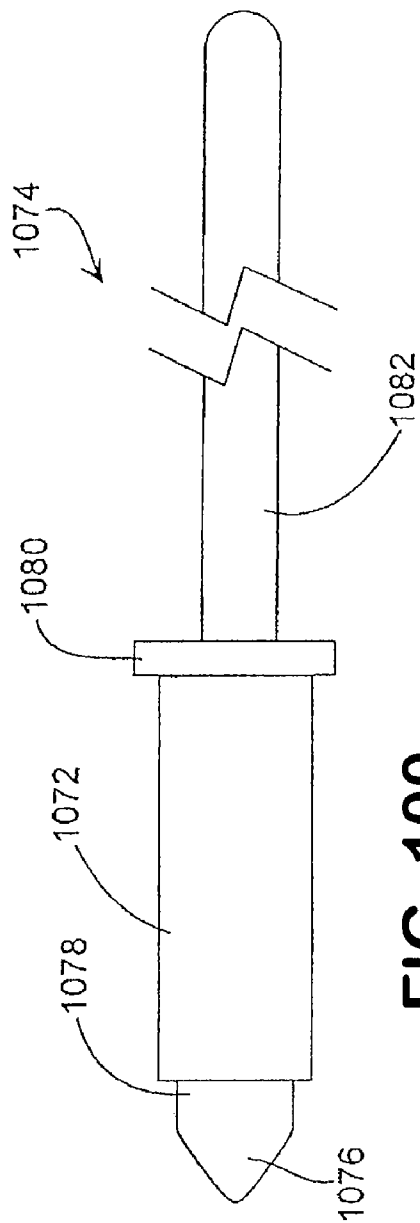

FIG. 100

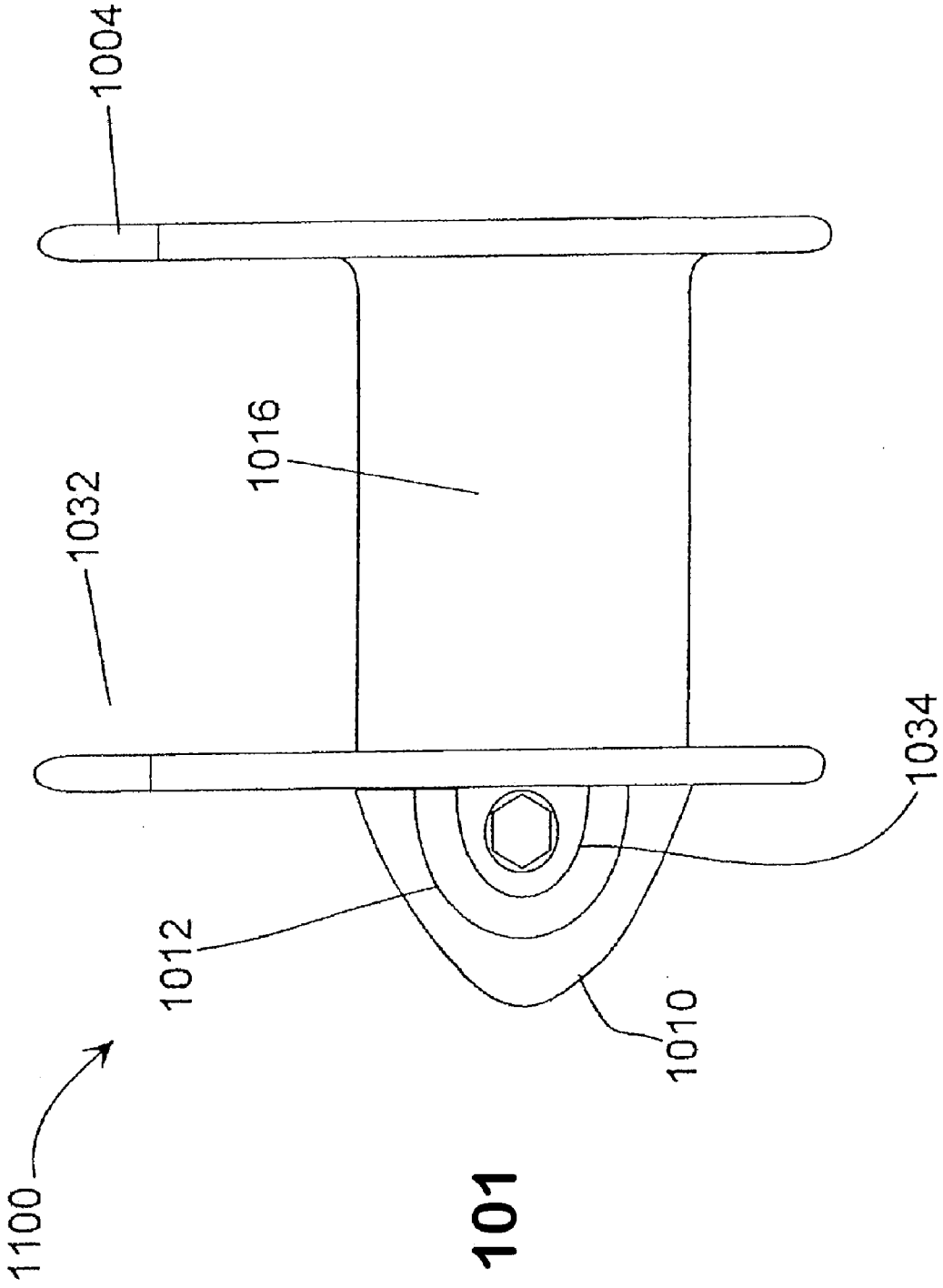

FIG. 101

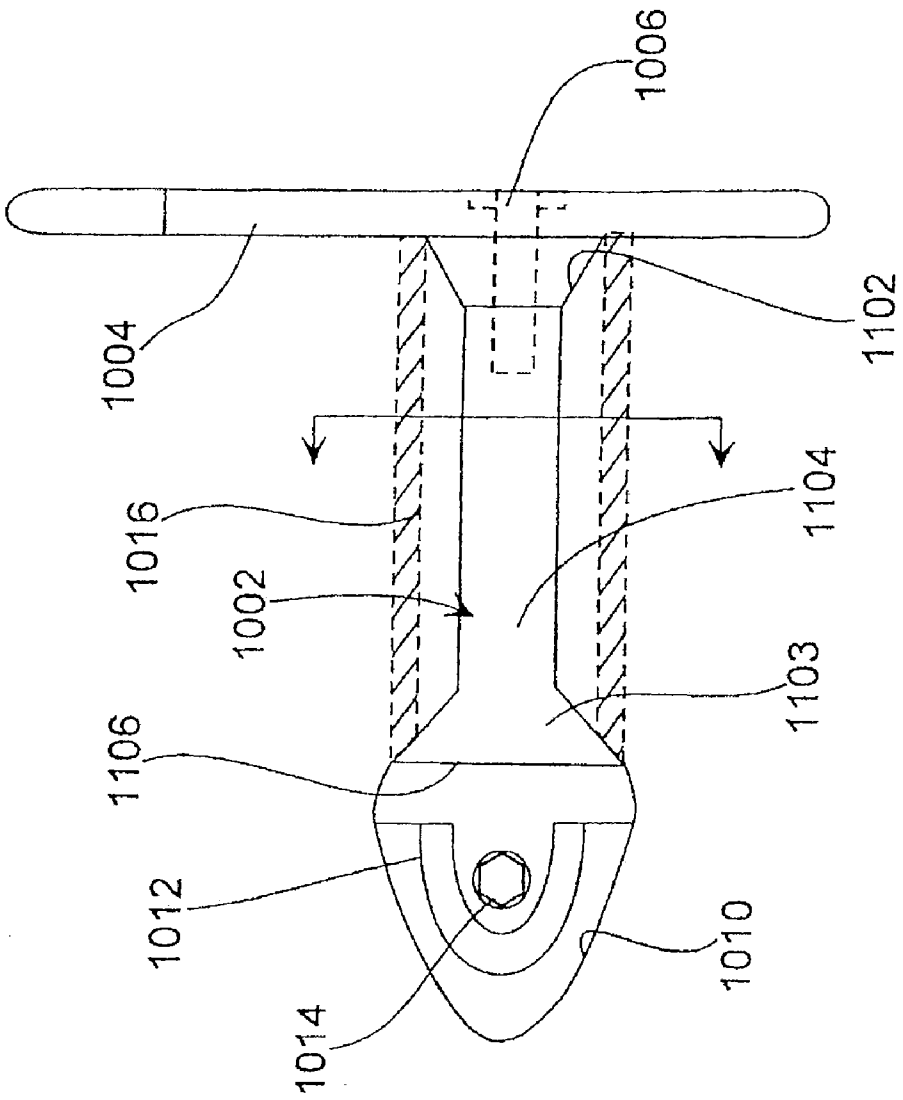

FIG. 102

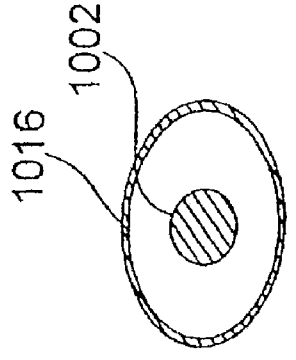

FIG. 102A

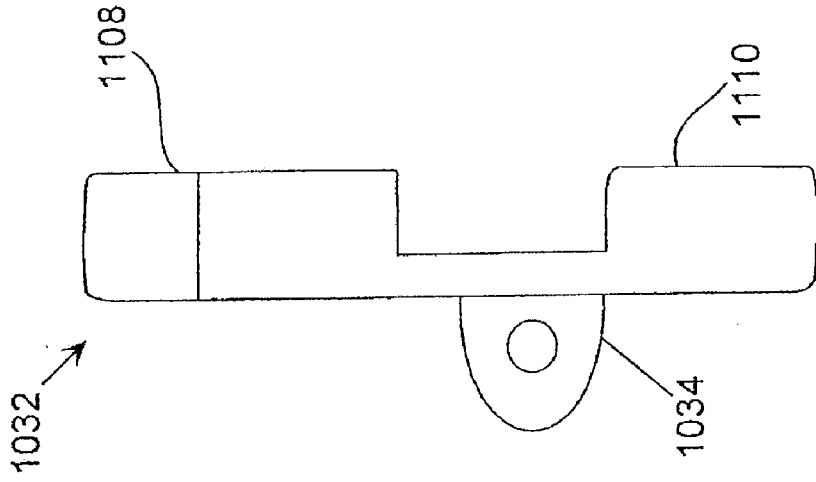

FIG. 103

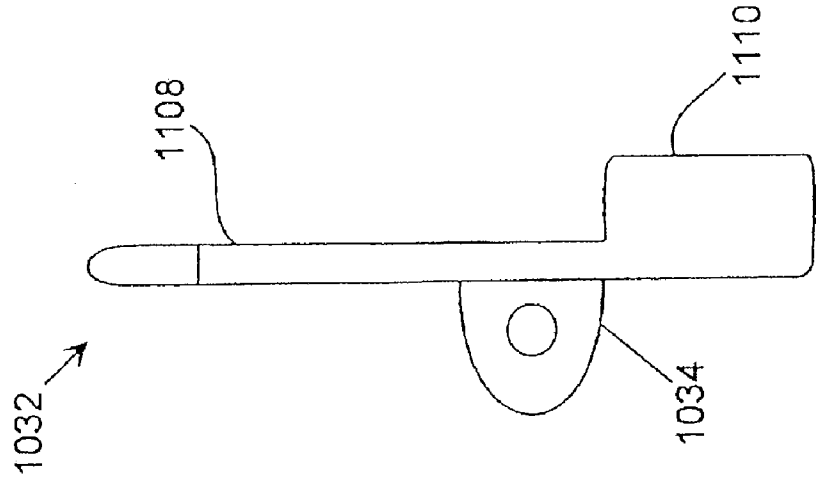

FIG. 104

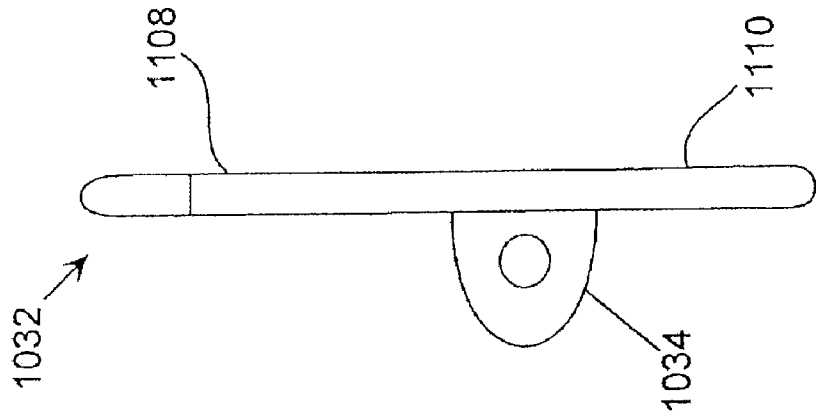

FIG. 105

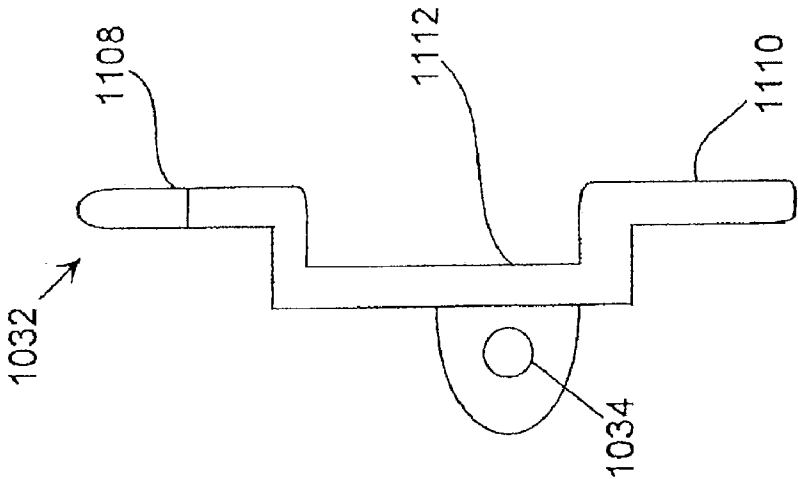

FIG. 106

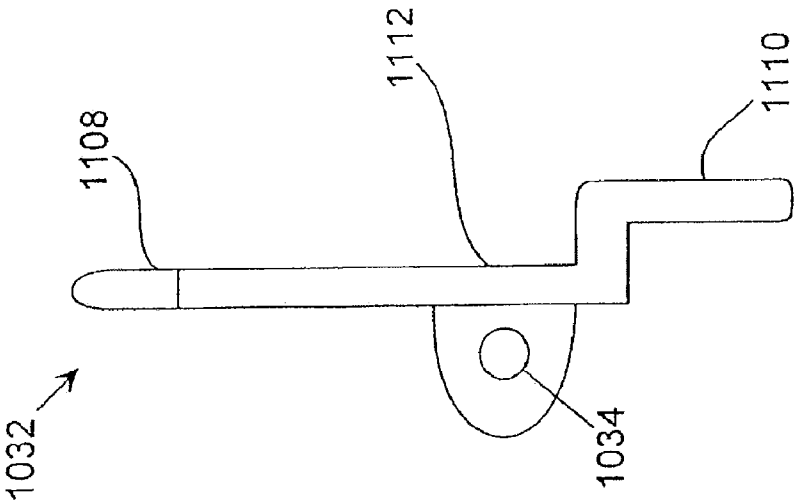

FIG. 107

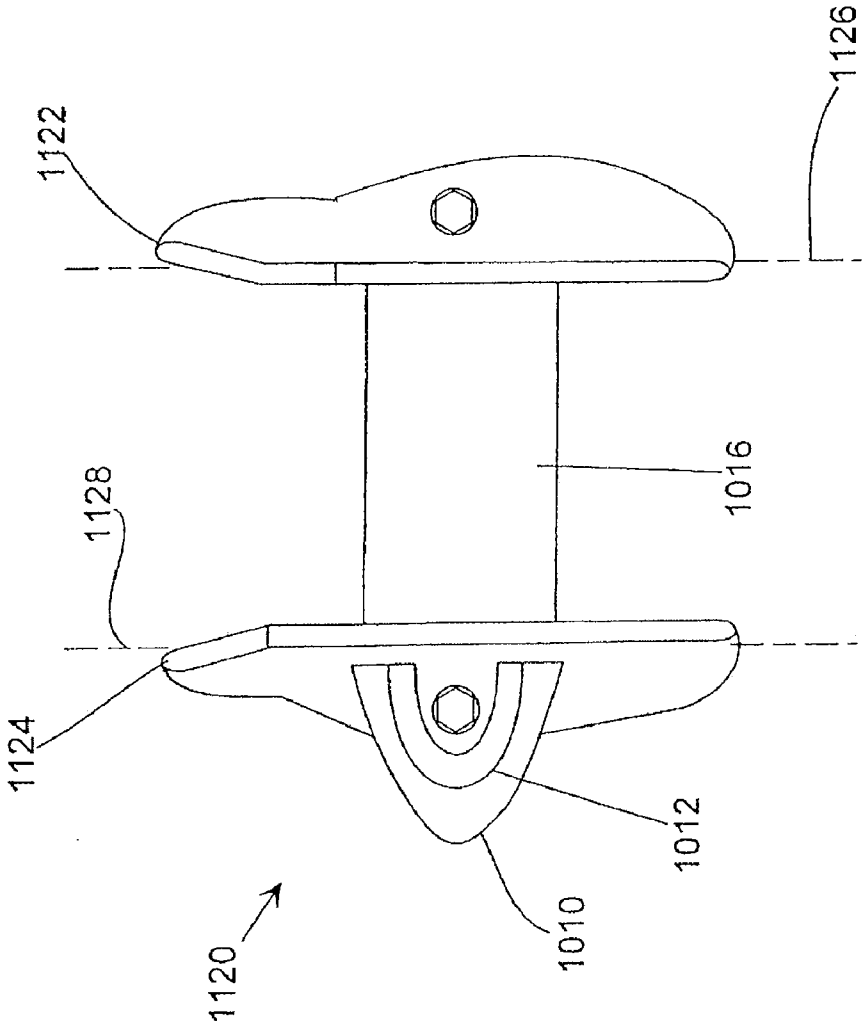
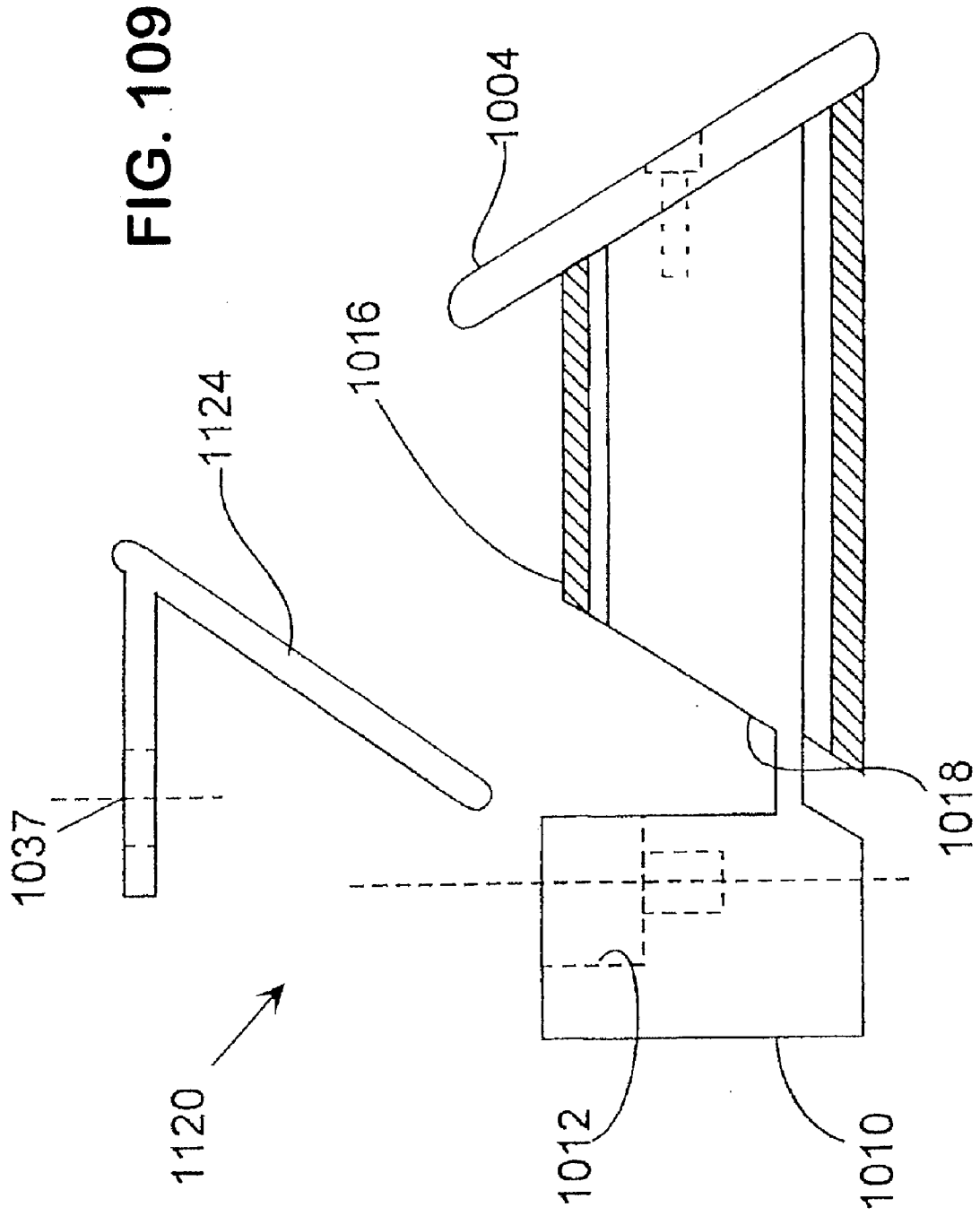

FIG. 108



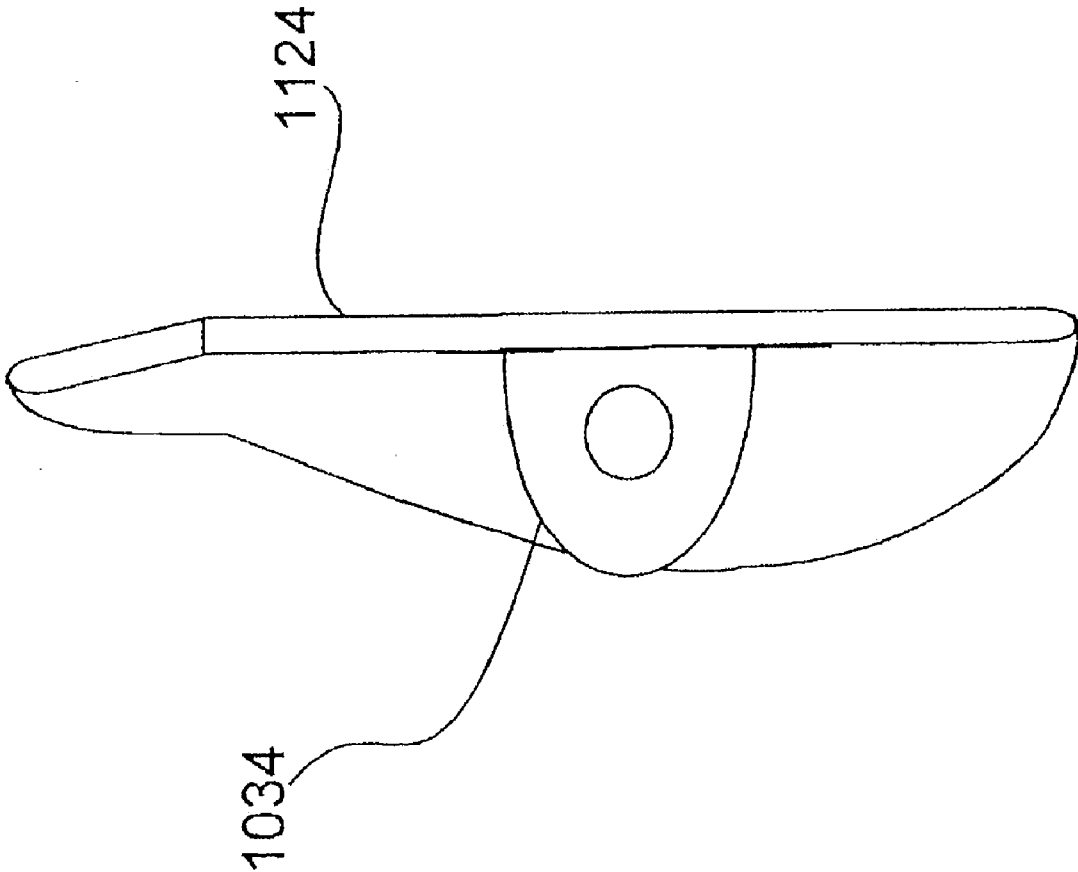

FIG. 110

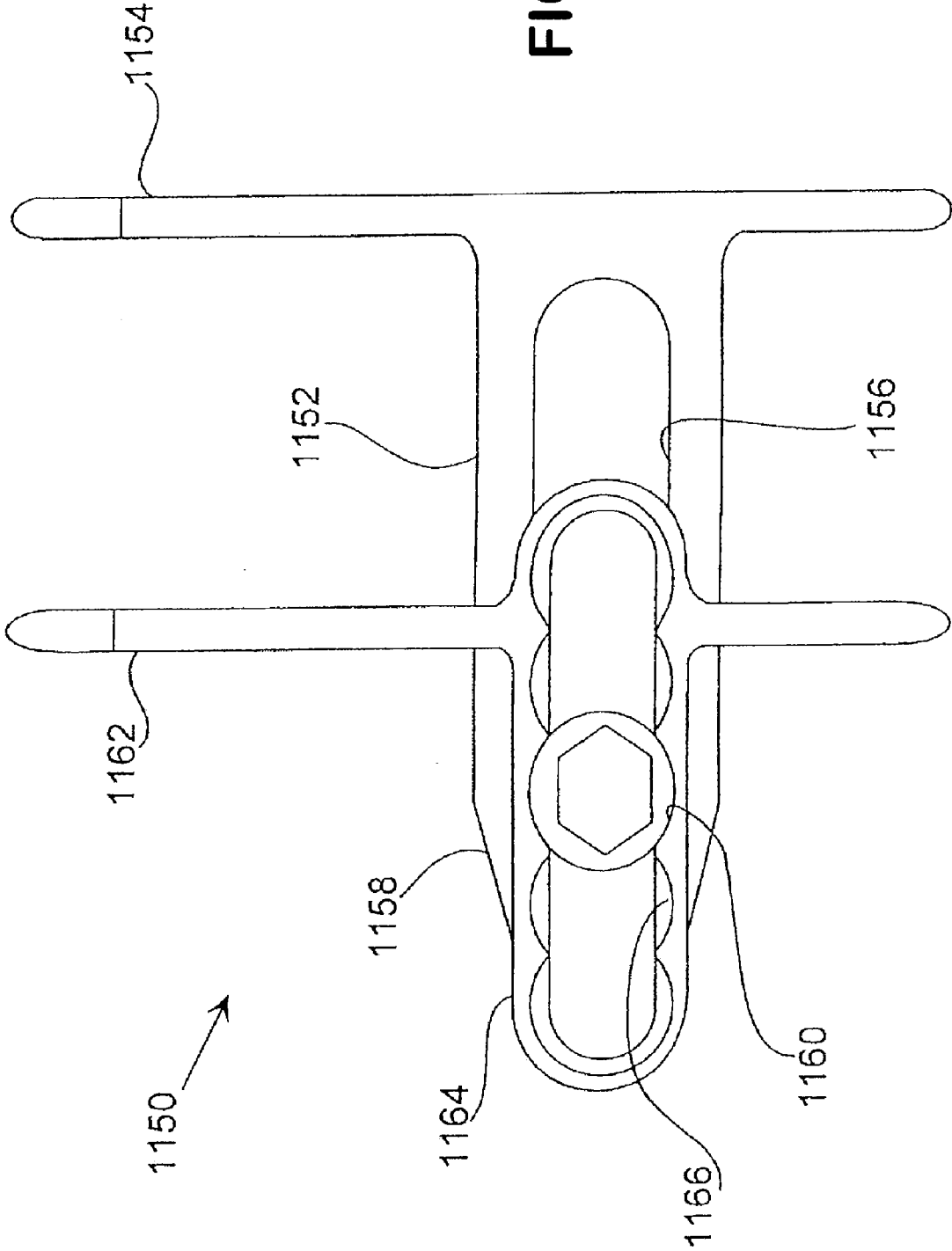
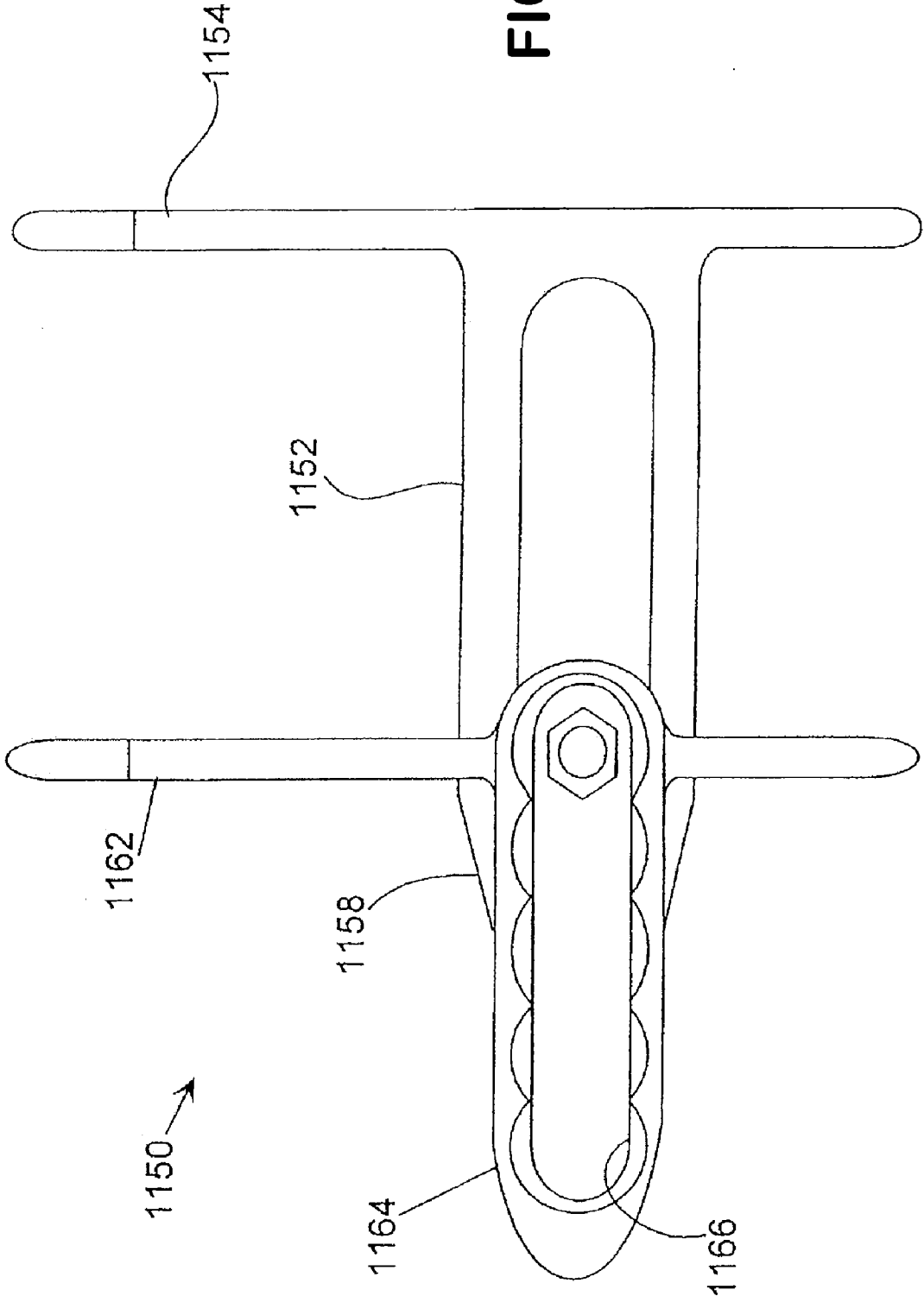

FIG. 111

FIG. 112



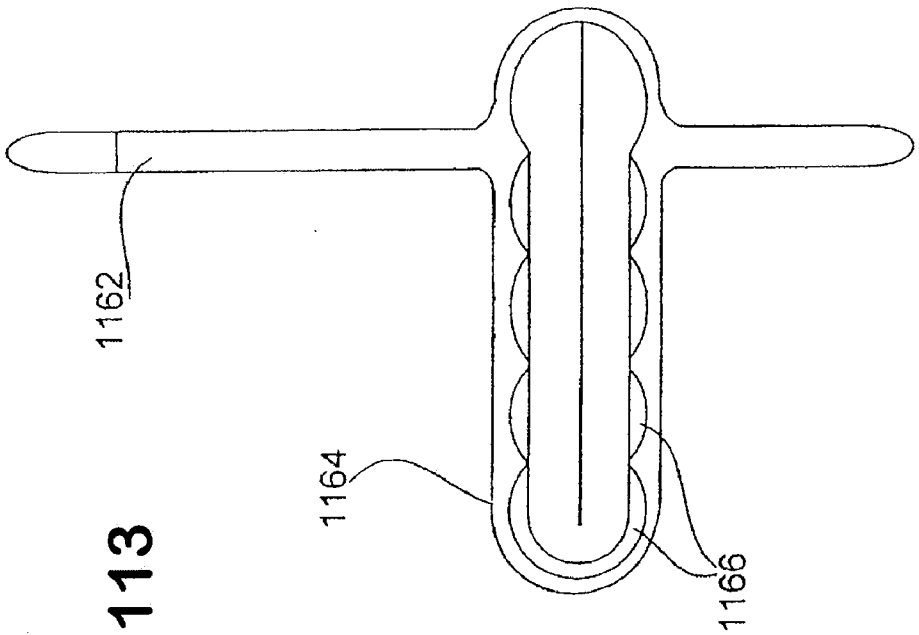

FIG. 113

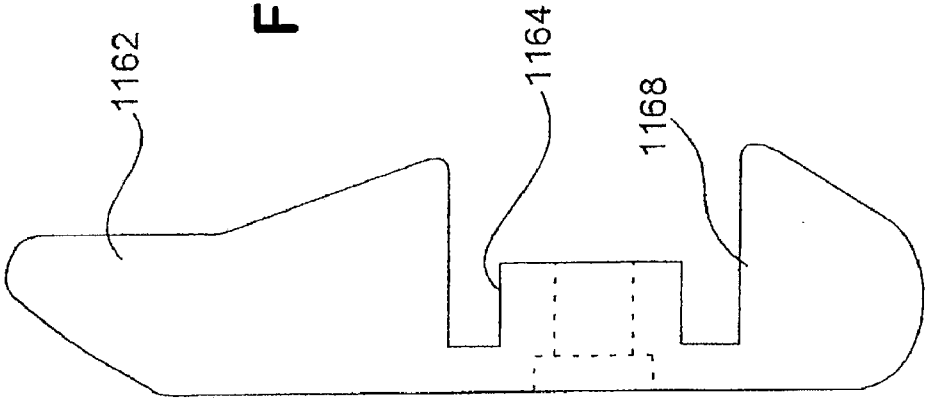

FIG. 114

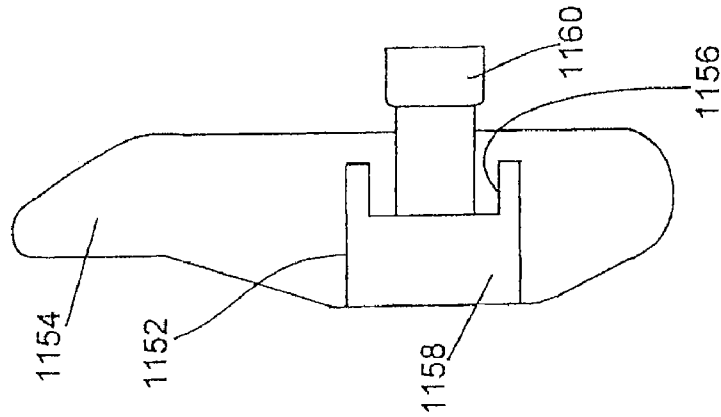
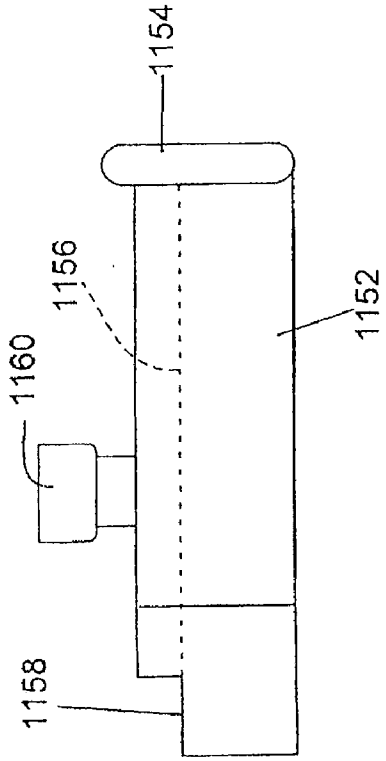
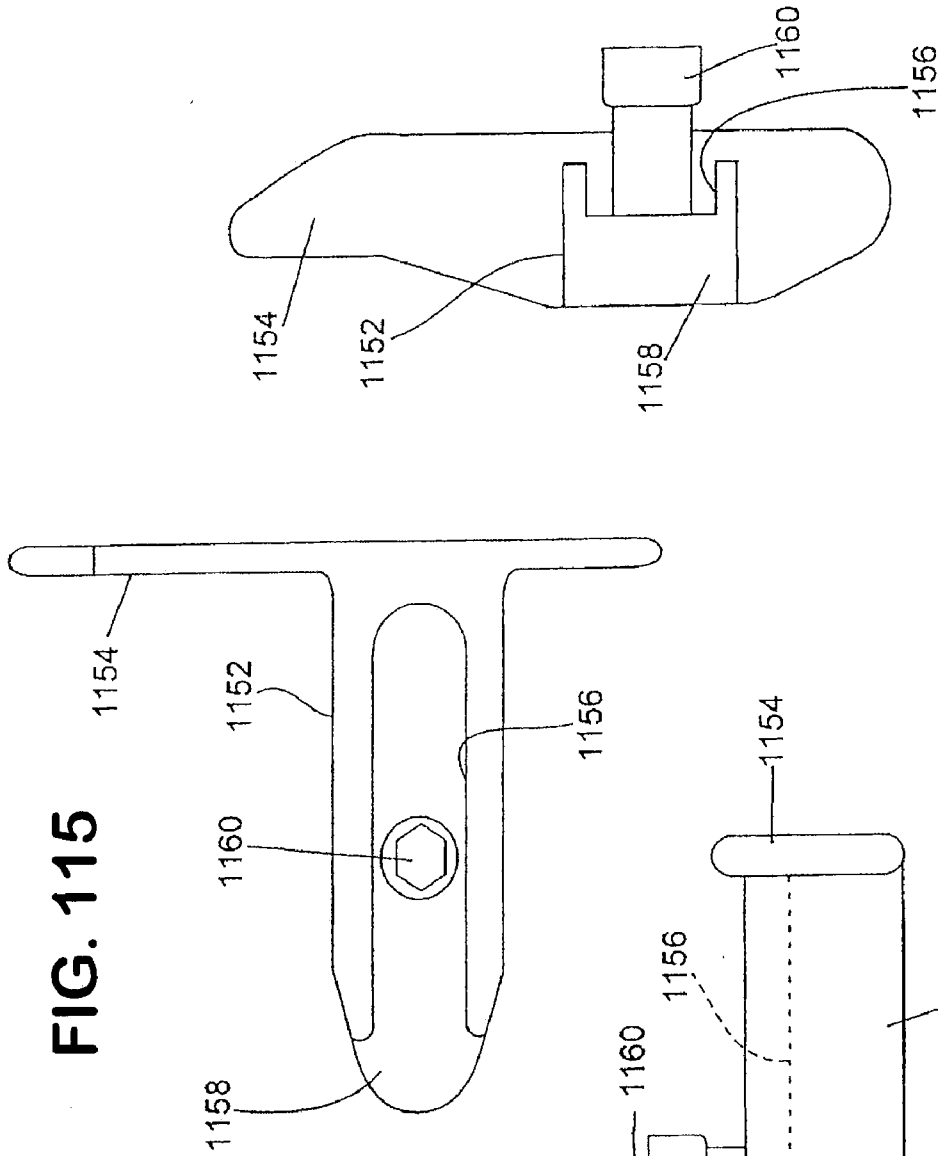
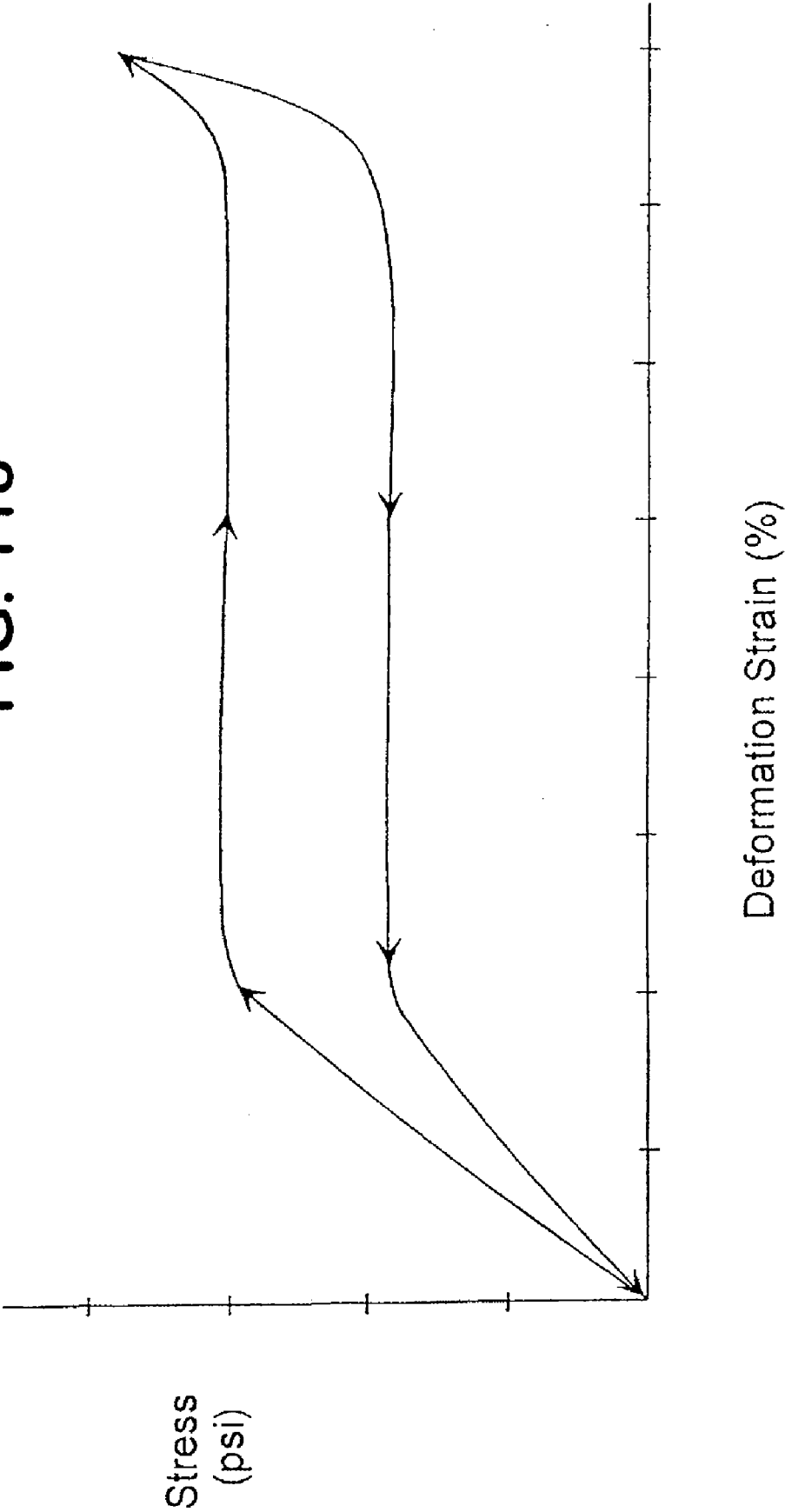

FIG. 118



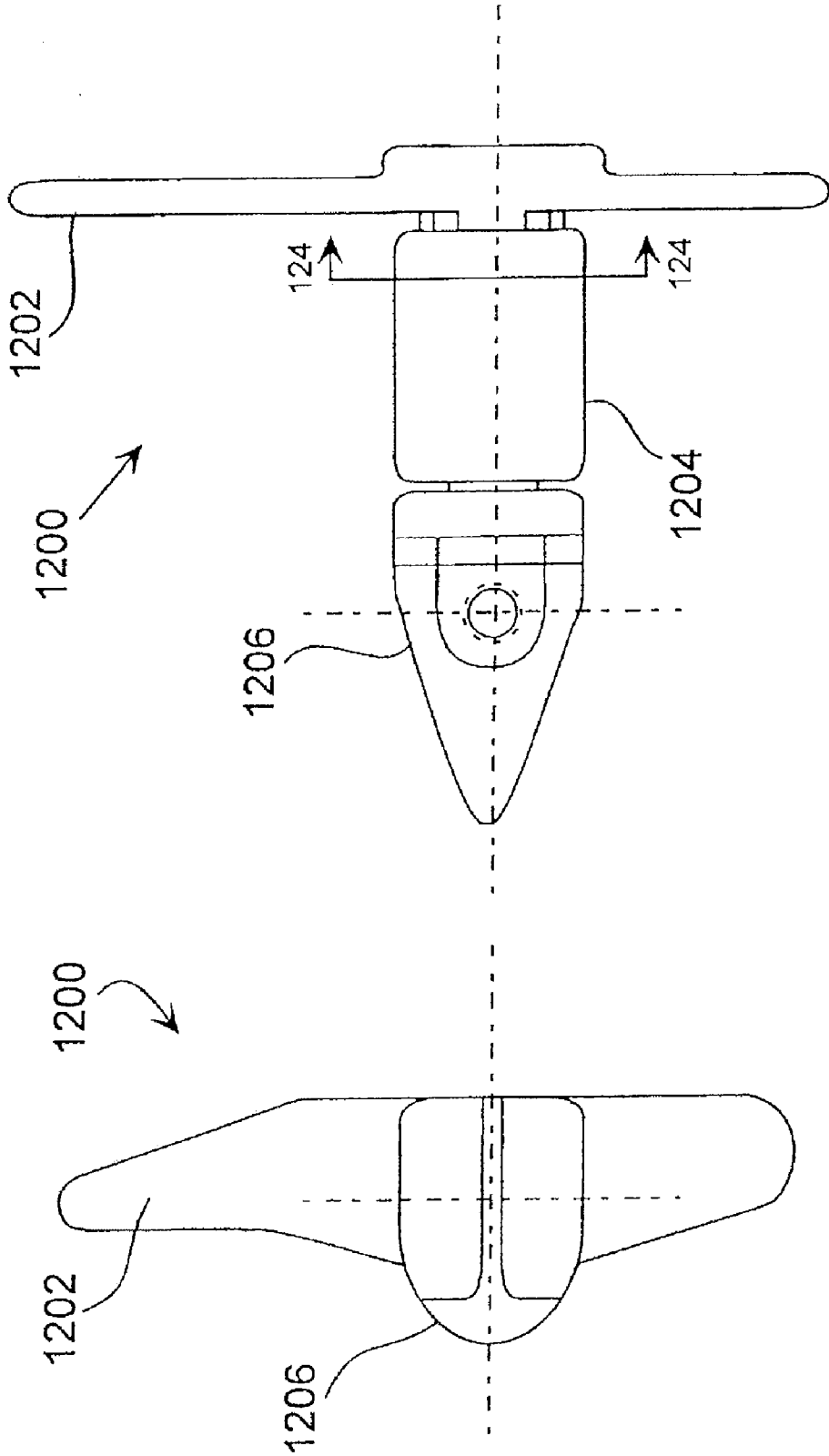

FIG. 119B

FIG. 119A

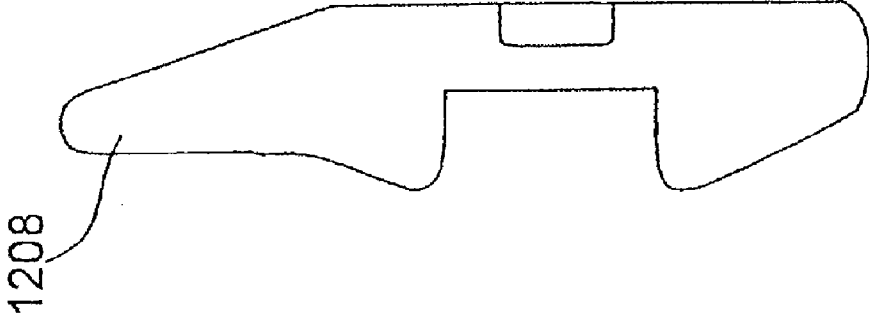

FIG. 120A

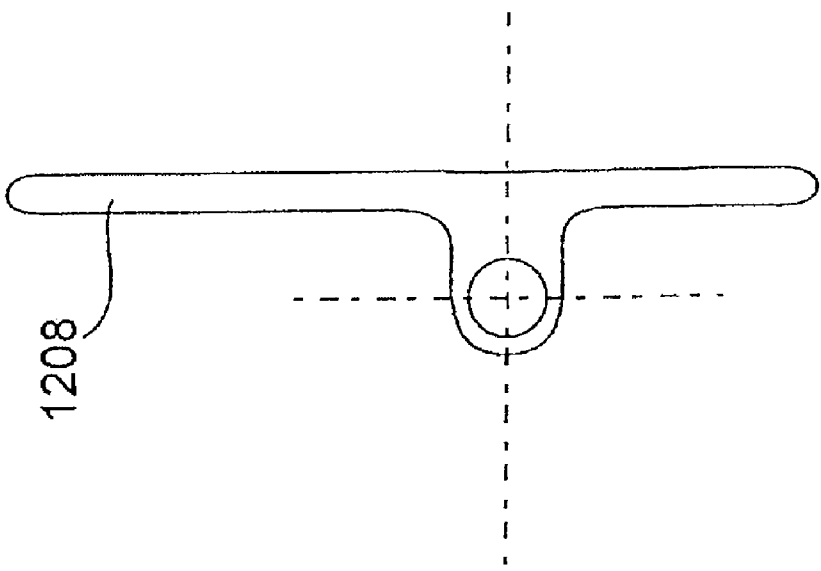

FIG. 120B

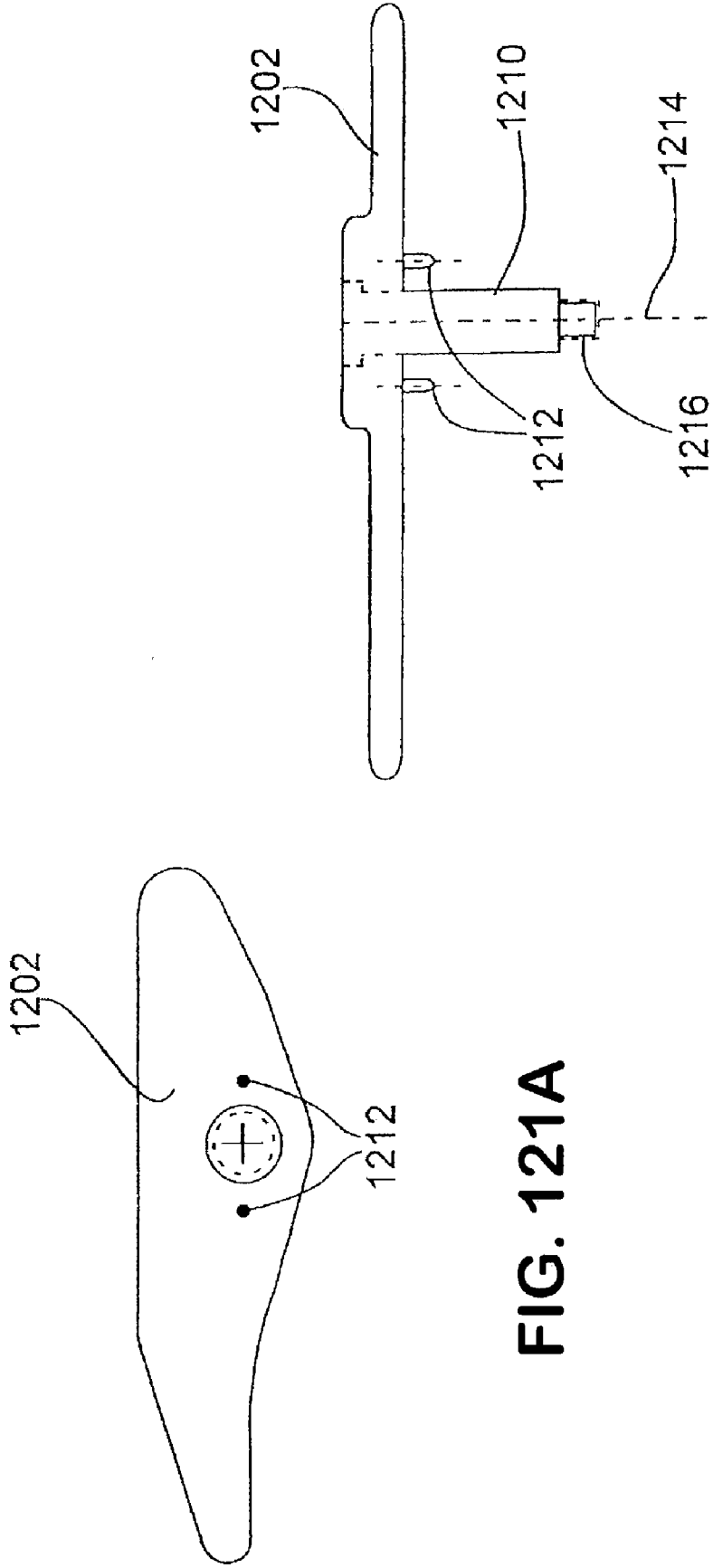

FIG. 121A

FIG. 121B

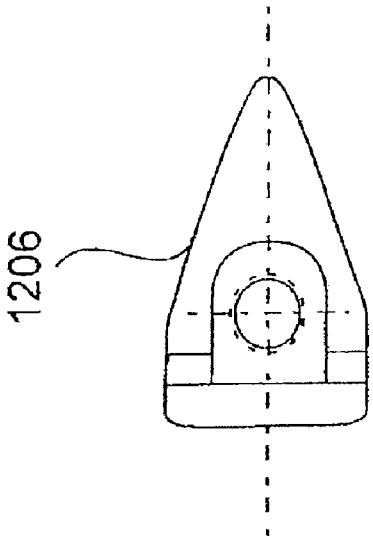

FIG. 122A

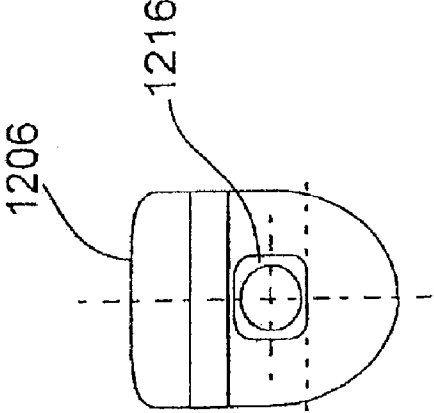

FIG. 122C

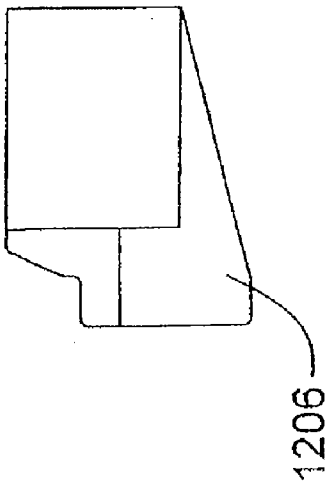

FIG. 122B

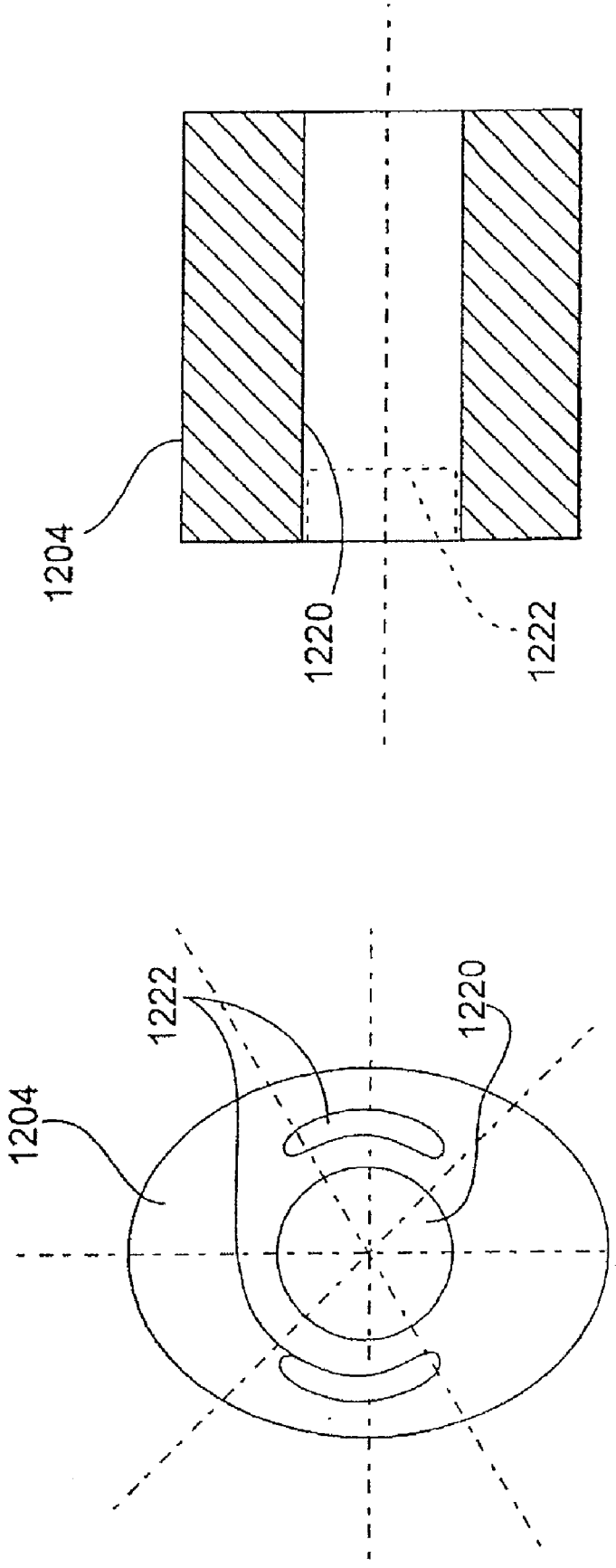

FIG. 123B

FIG. 123A

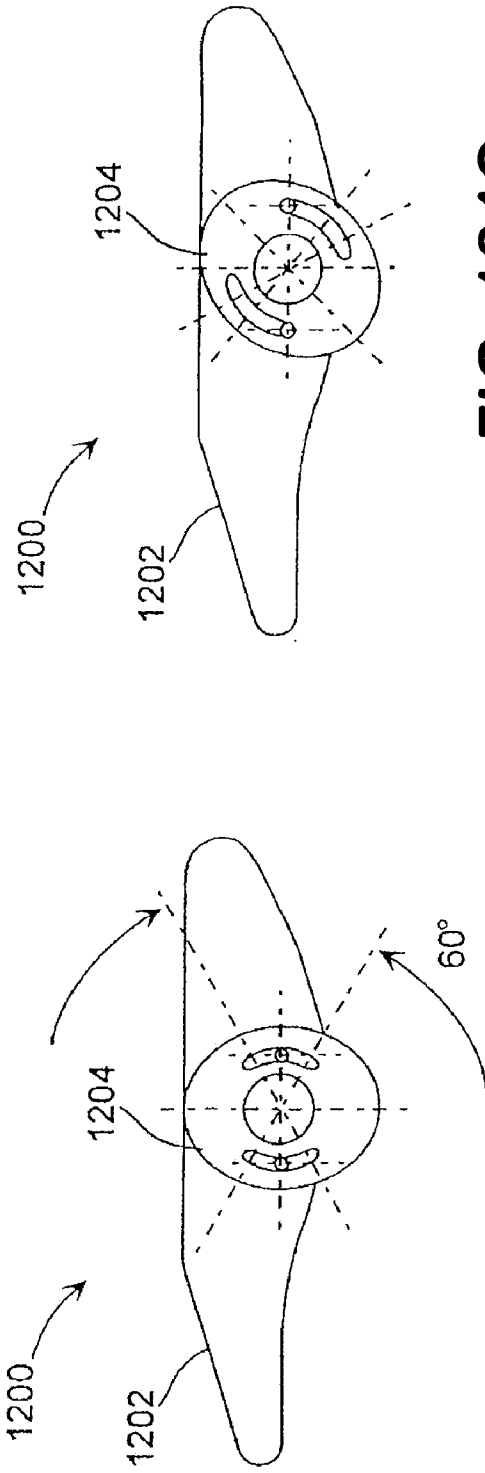

FIG. 124C

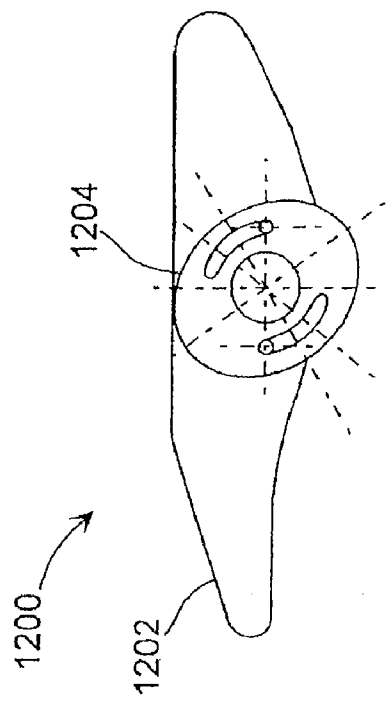

FIG. 124B

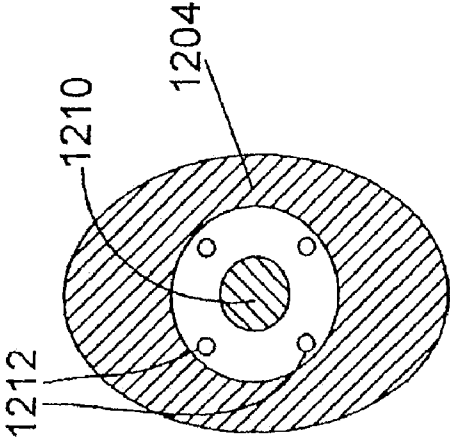

FIG. 125

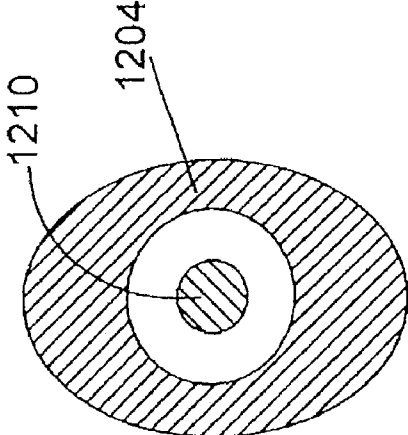

FIG. 126

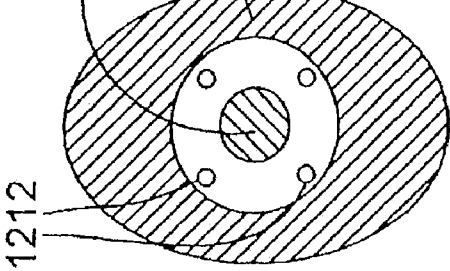

FIG. 127

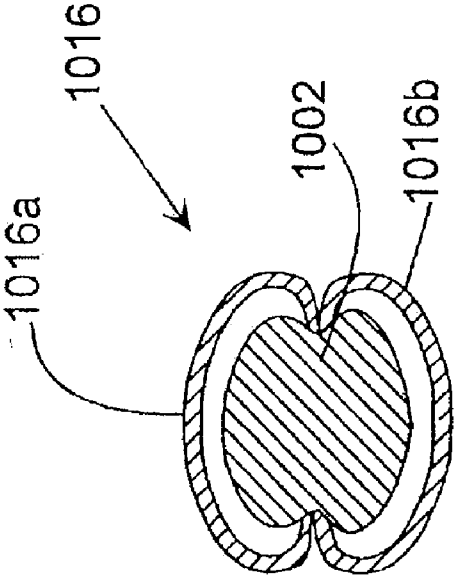

FIG. 128

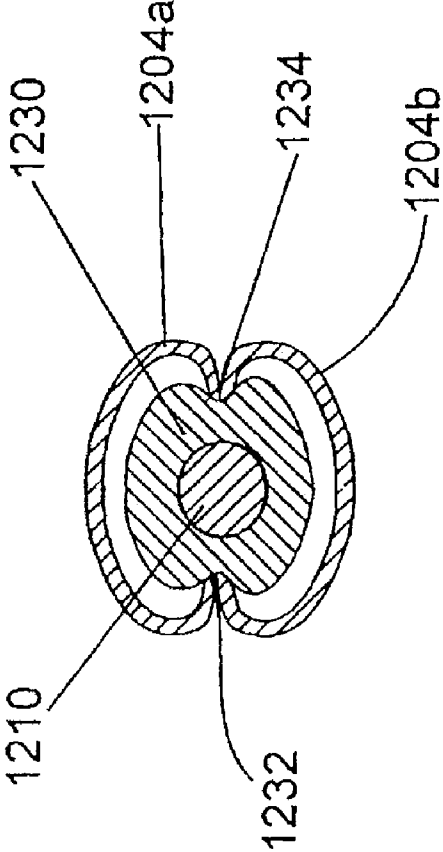

FIG. 129

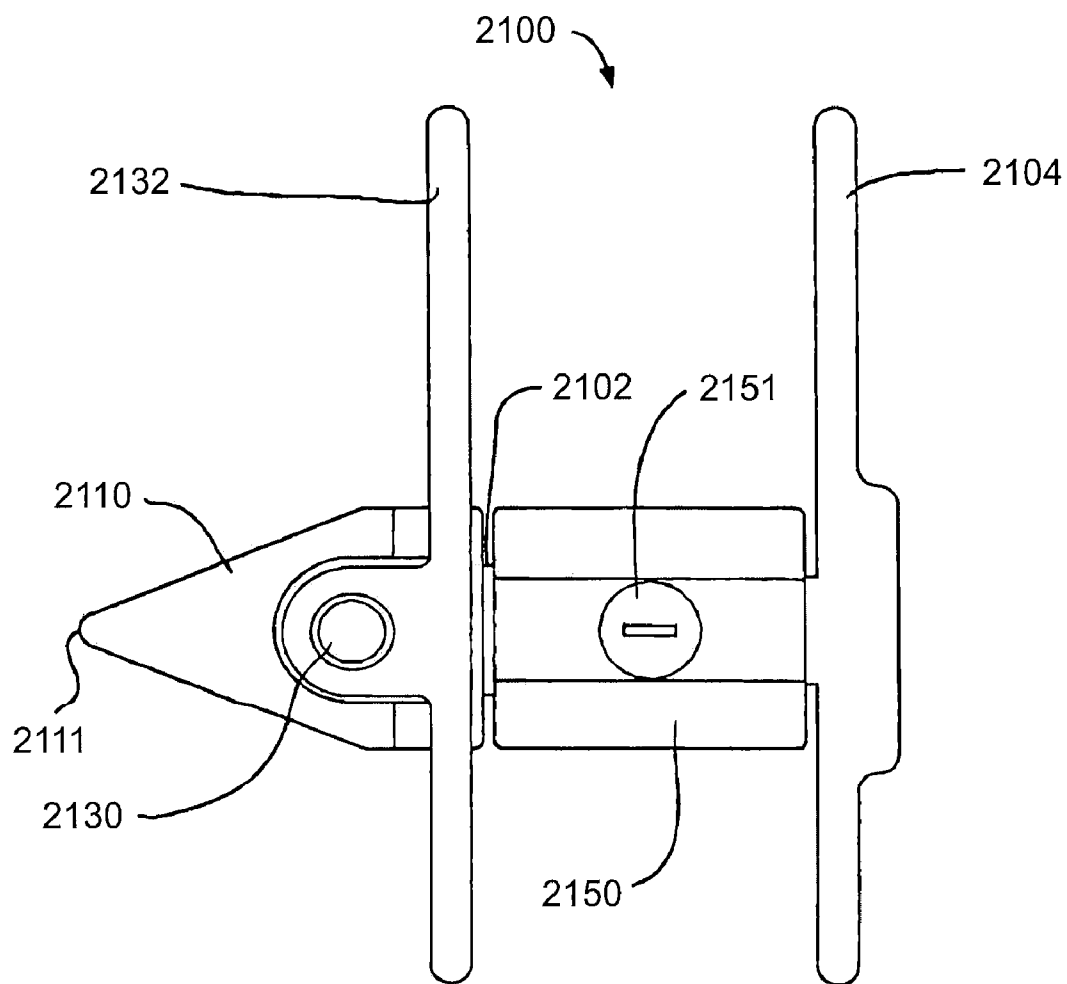

FIG. 130A

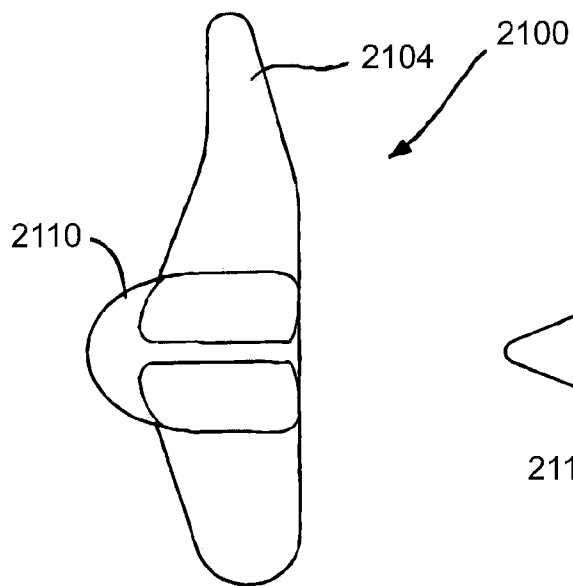

FIG. 130B

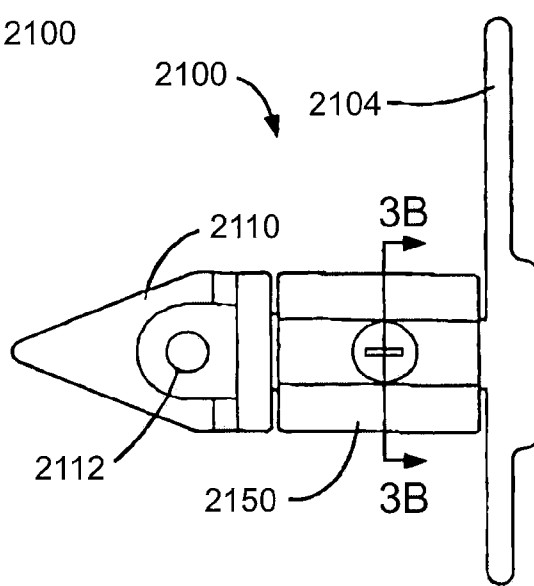

FIG. 130C

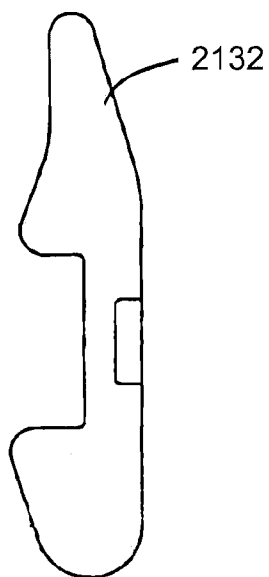

FIG. 130D

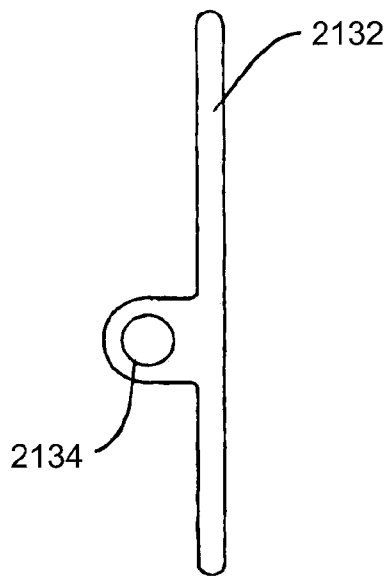

FIG. 130E

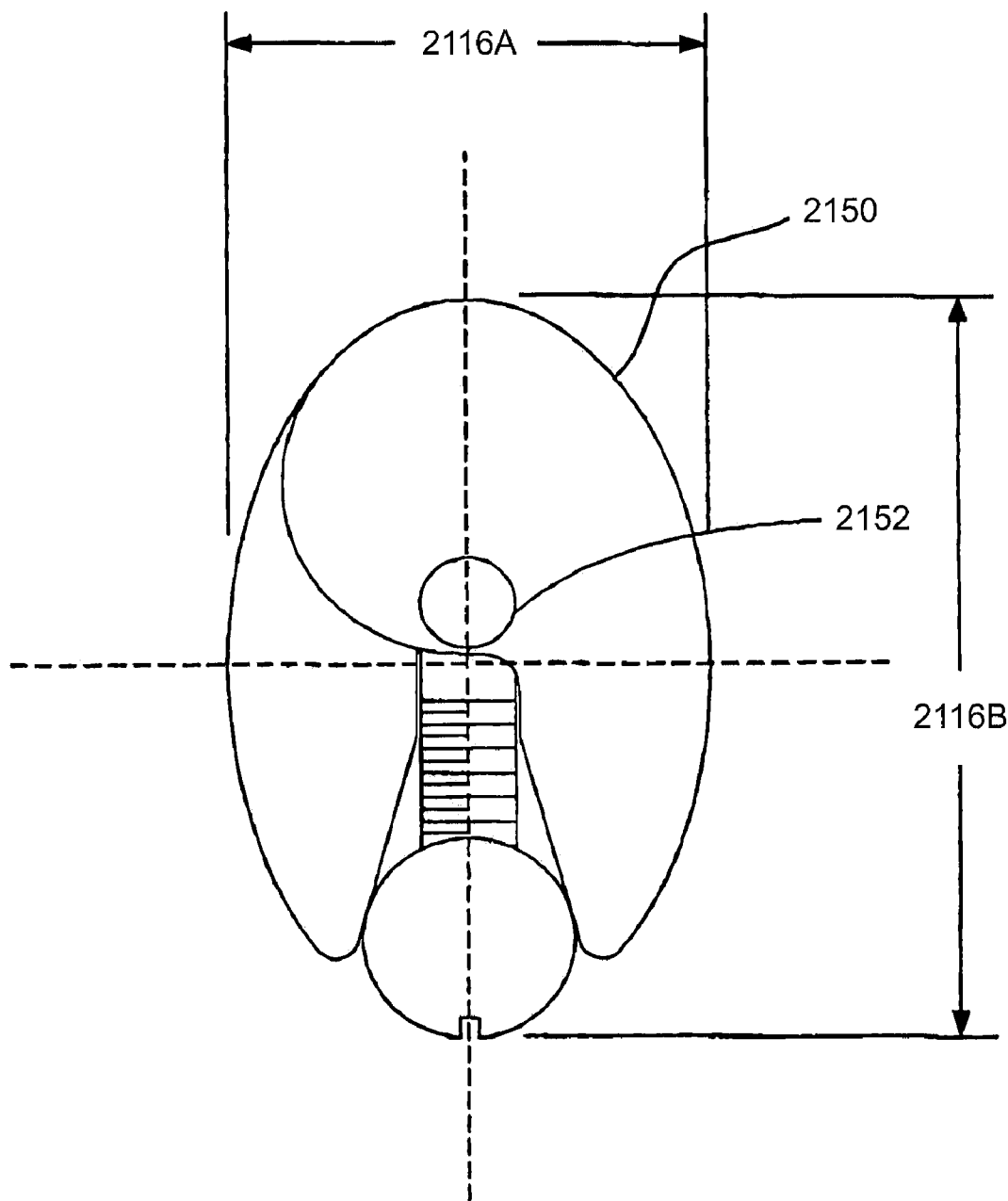

FIG. 130F

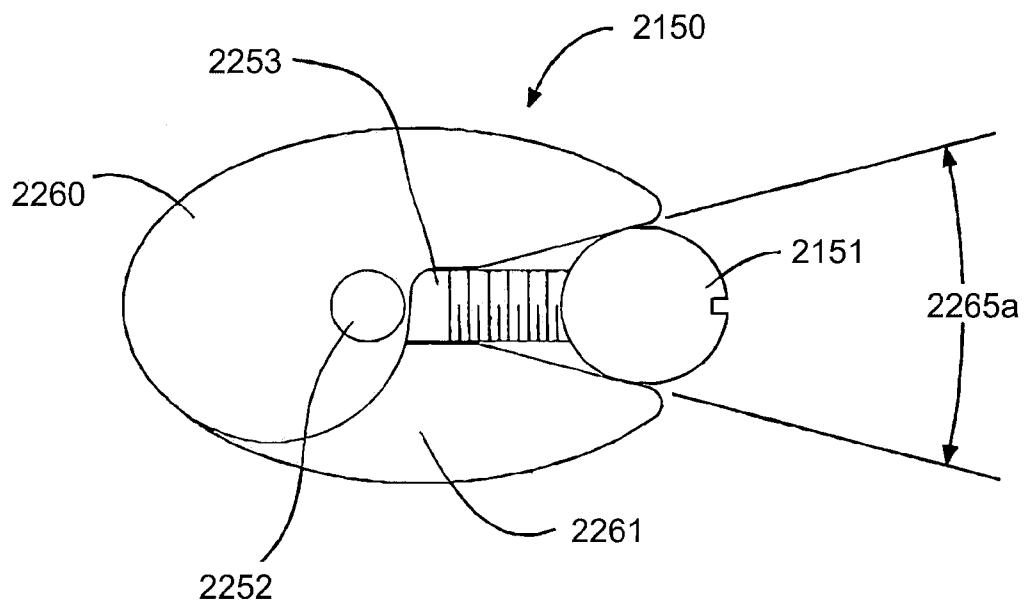

FIG. 131A

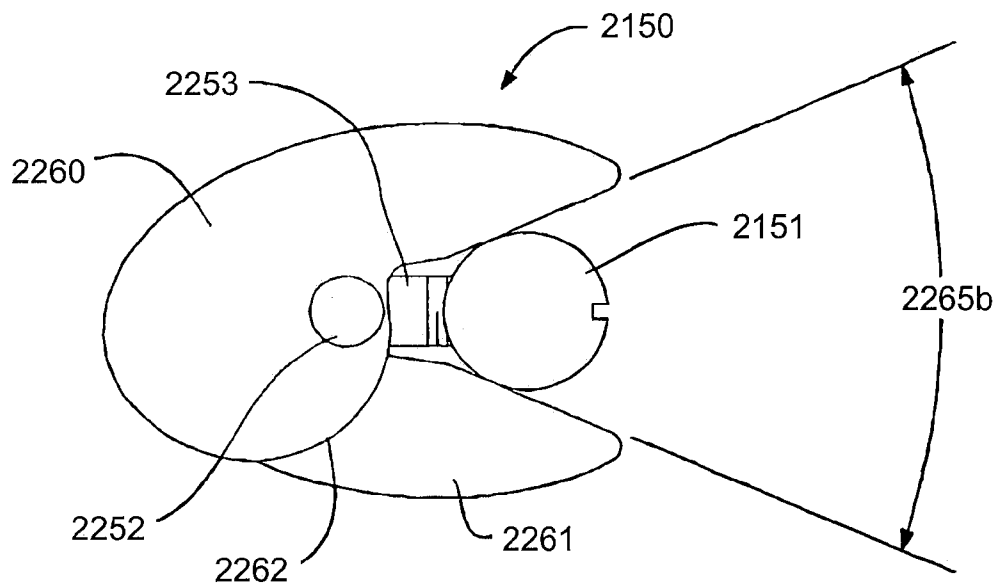

FIG. 131B

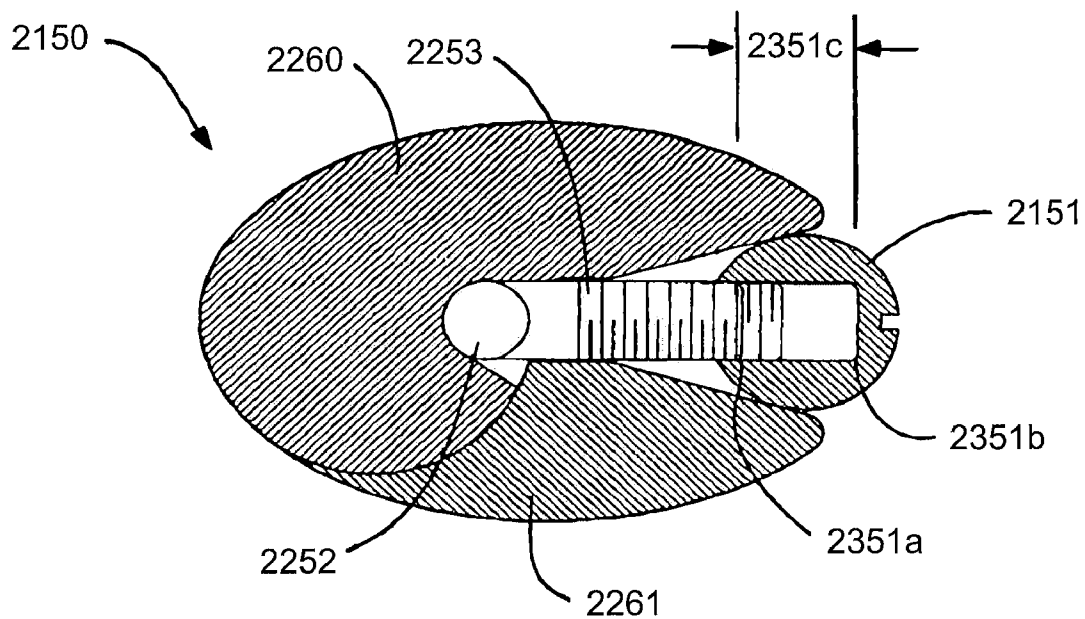

FIG. 132A

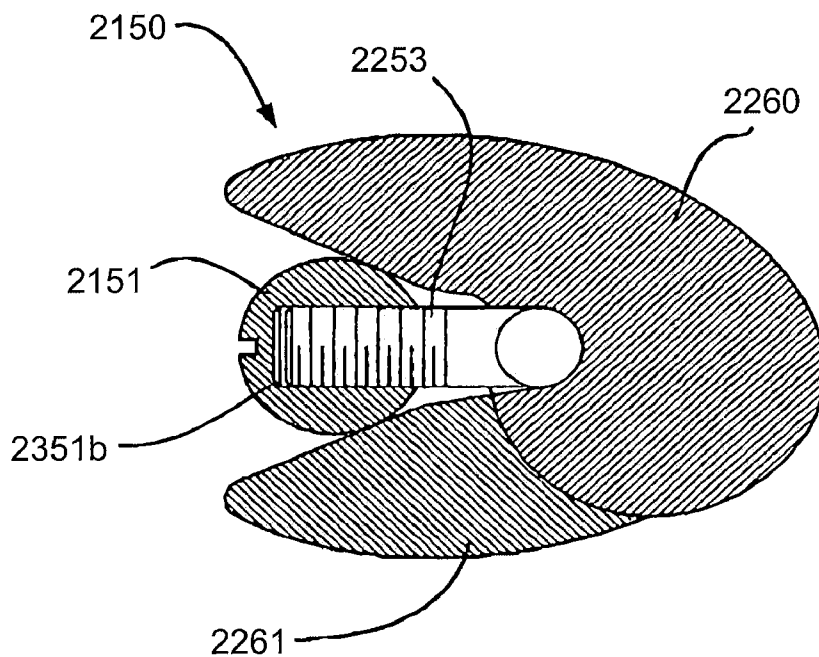

FIG. 132B

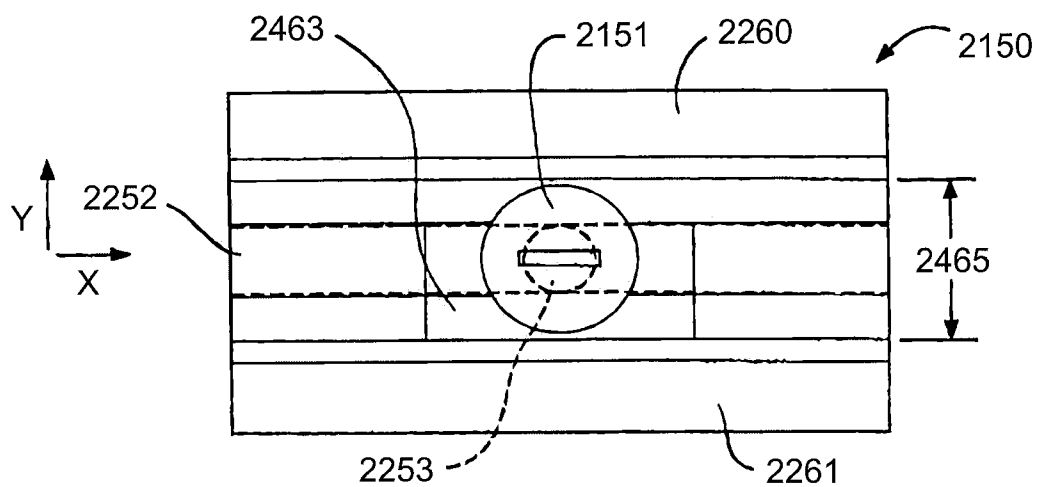

FIG. 133

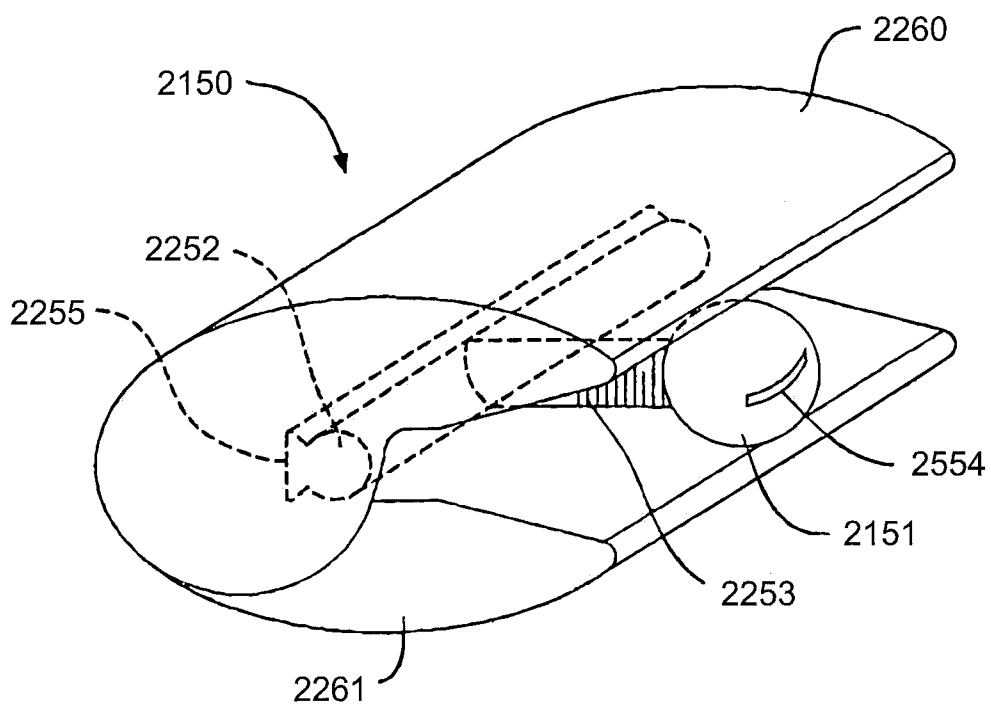

FIG. 134A

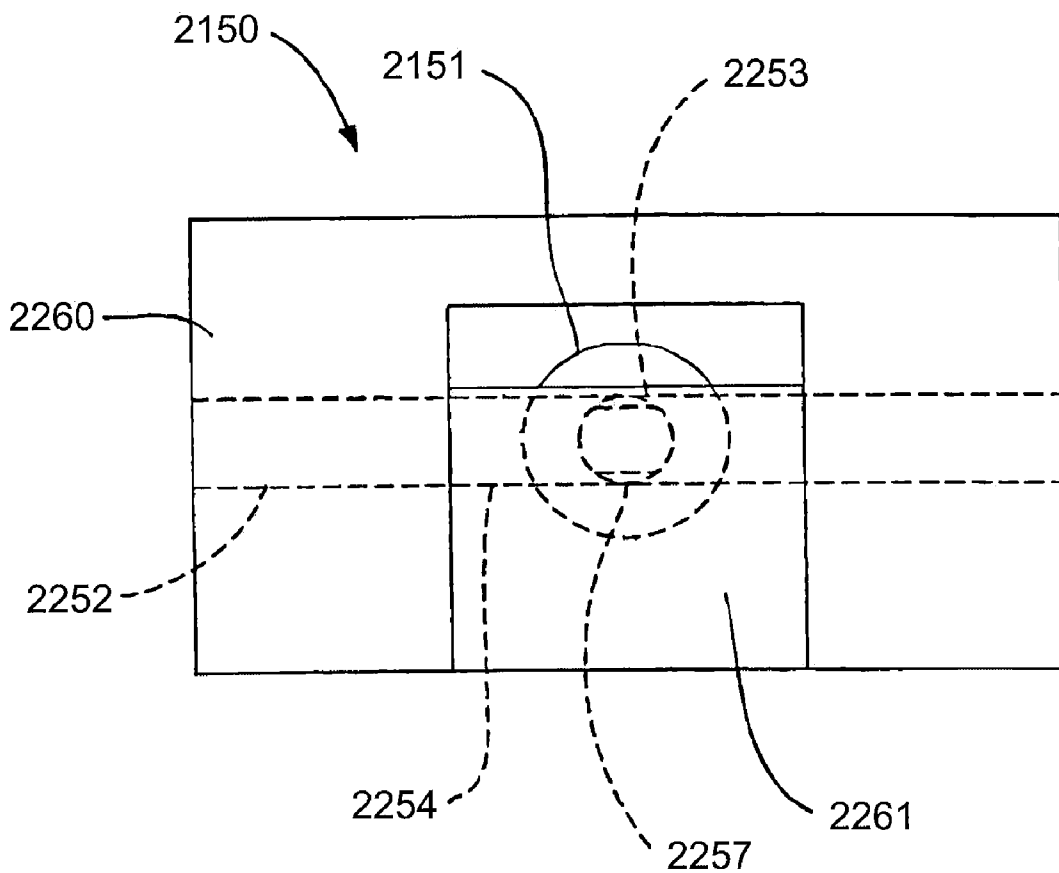

FIG. 134B

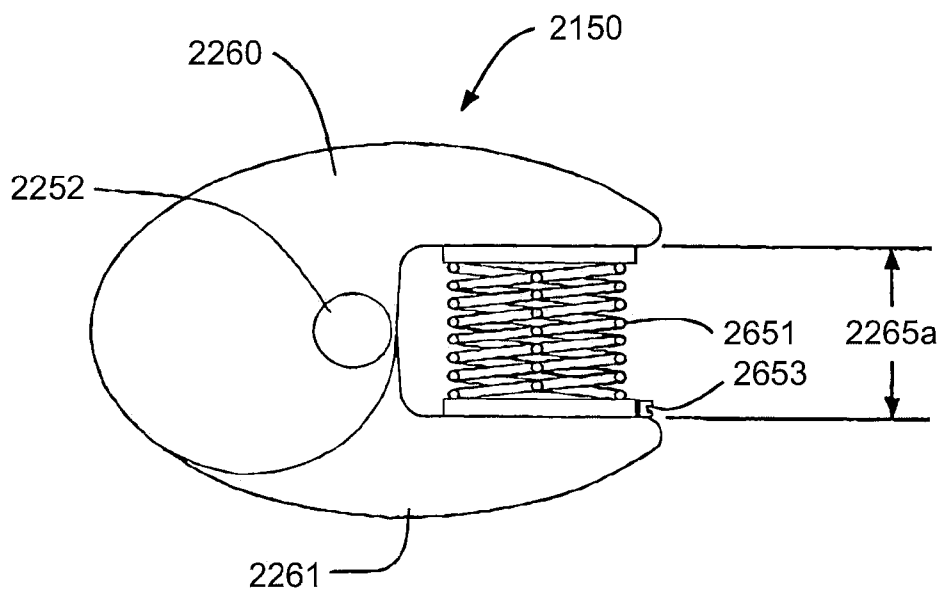

FIG. 135A

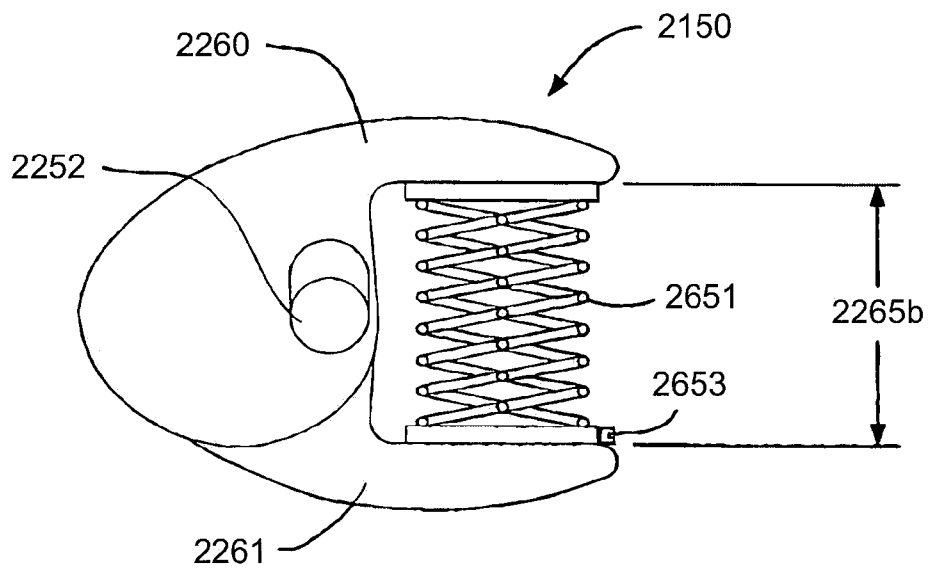

FIG. 135B

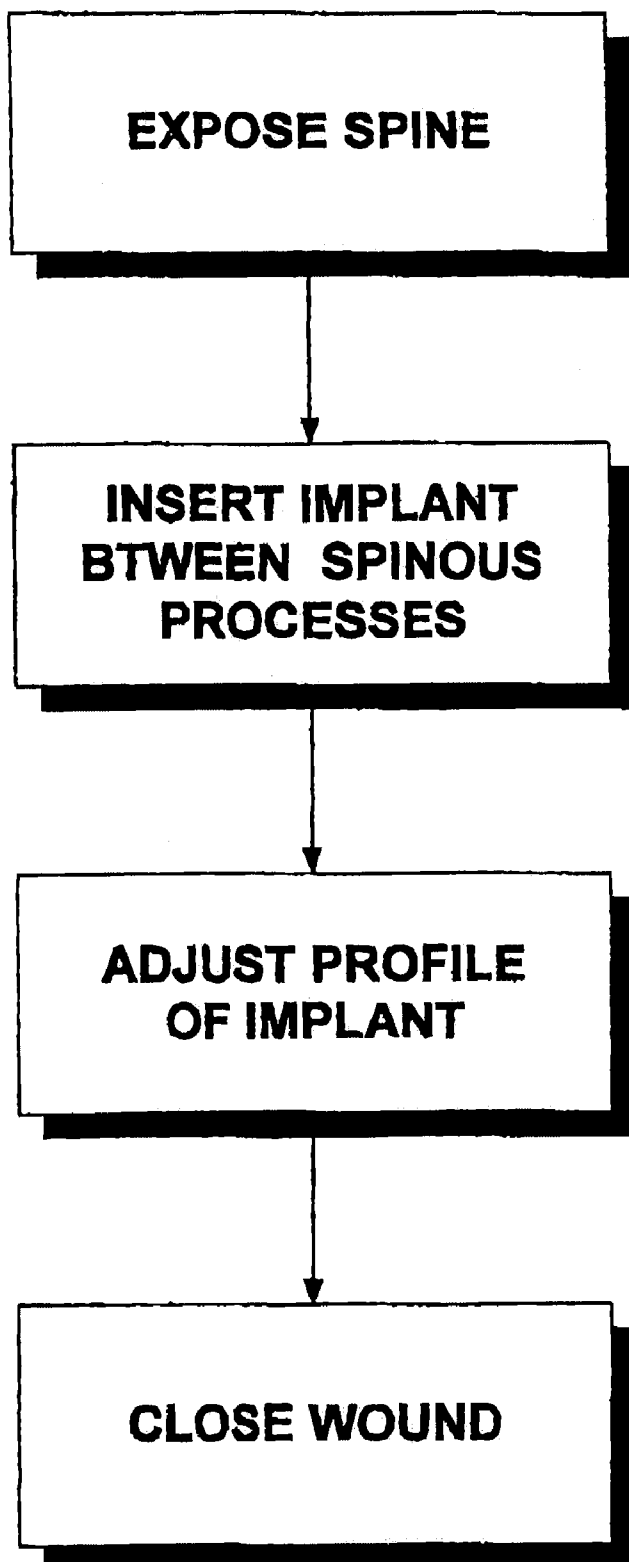

FIG. 136

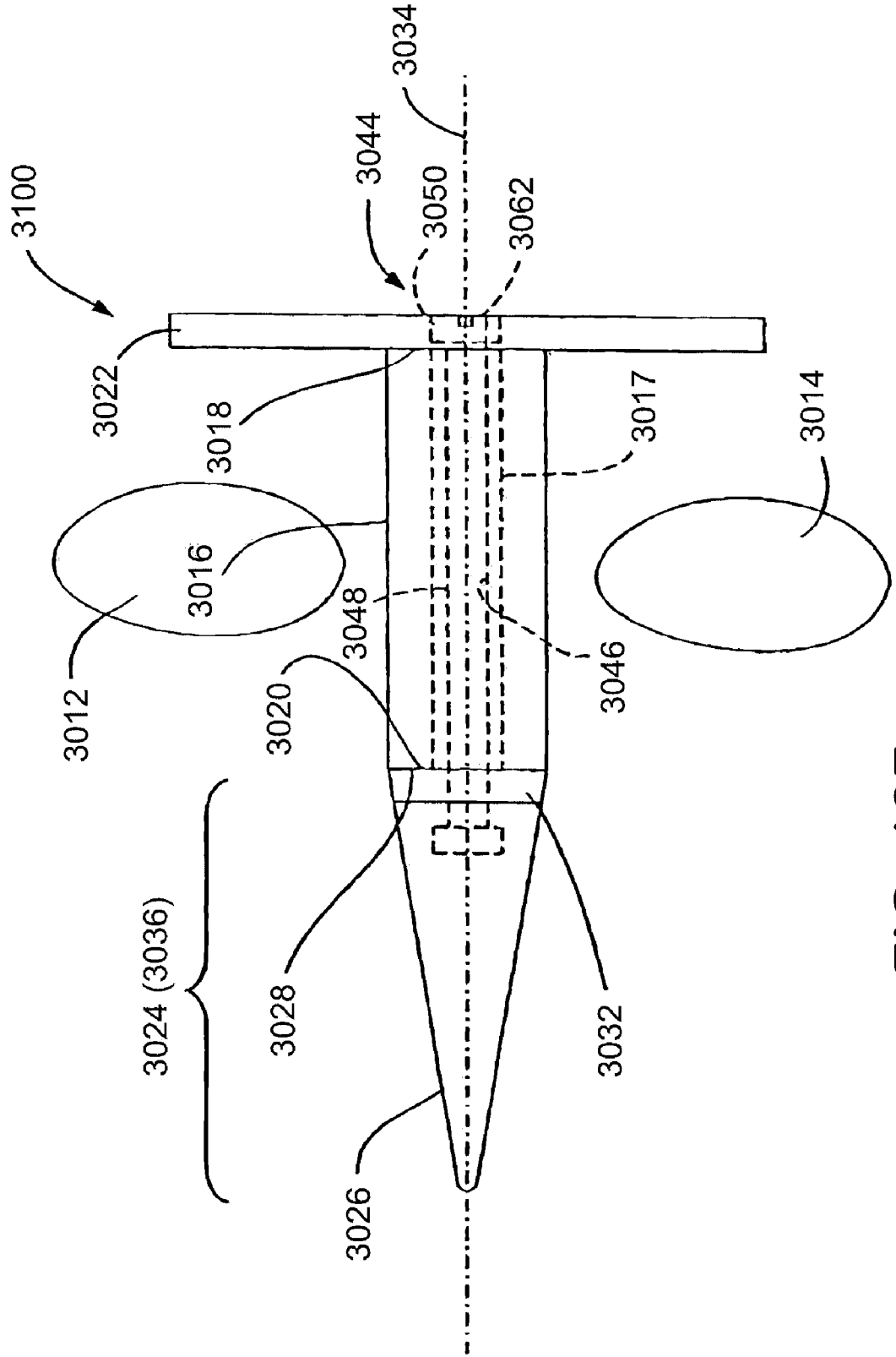

FIG. 137

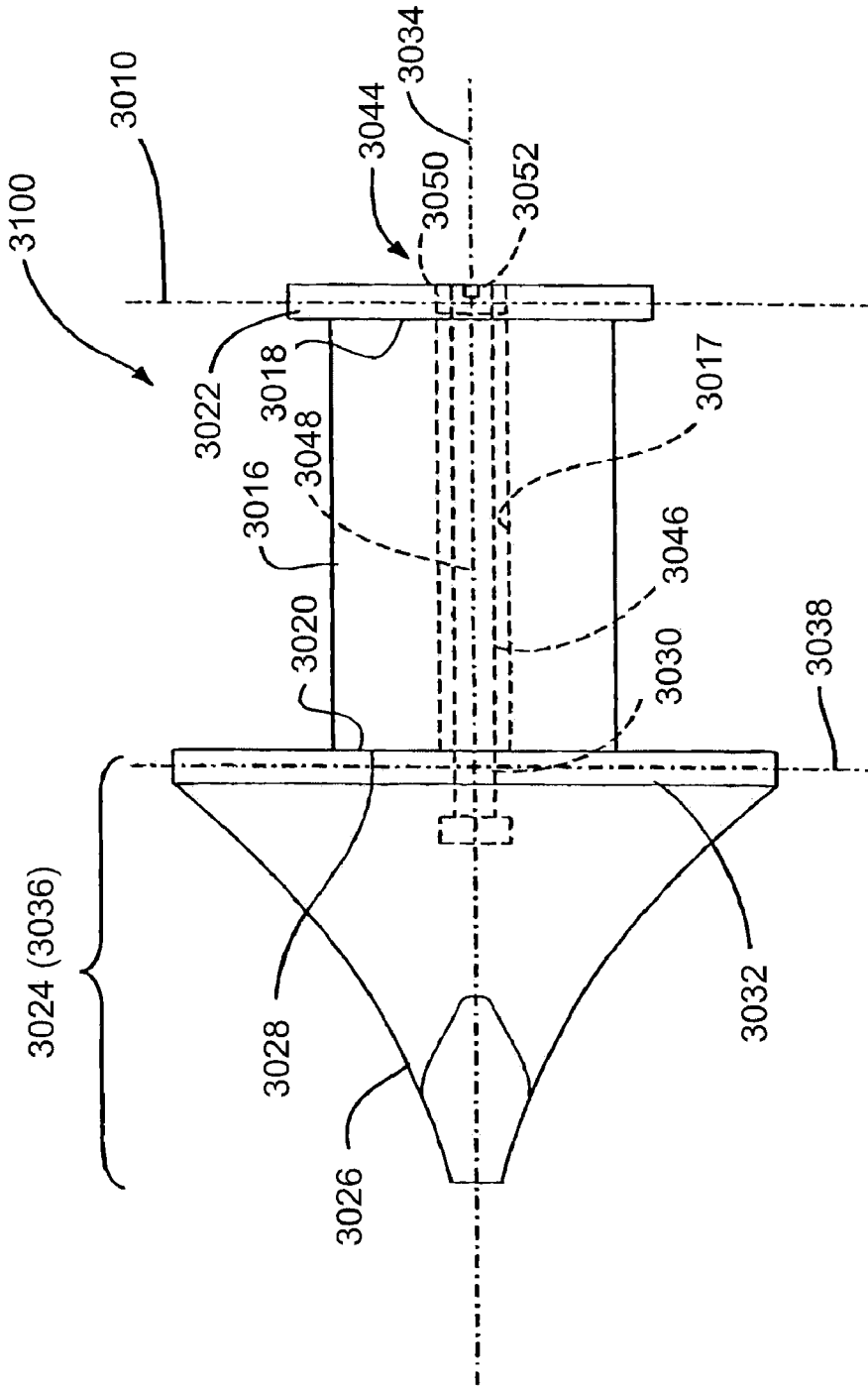

FIG. 138

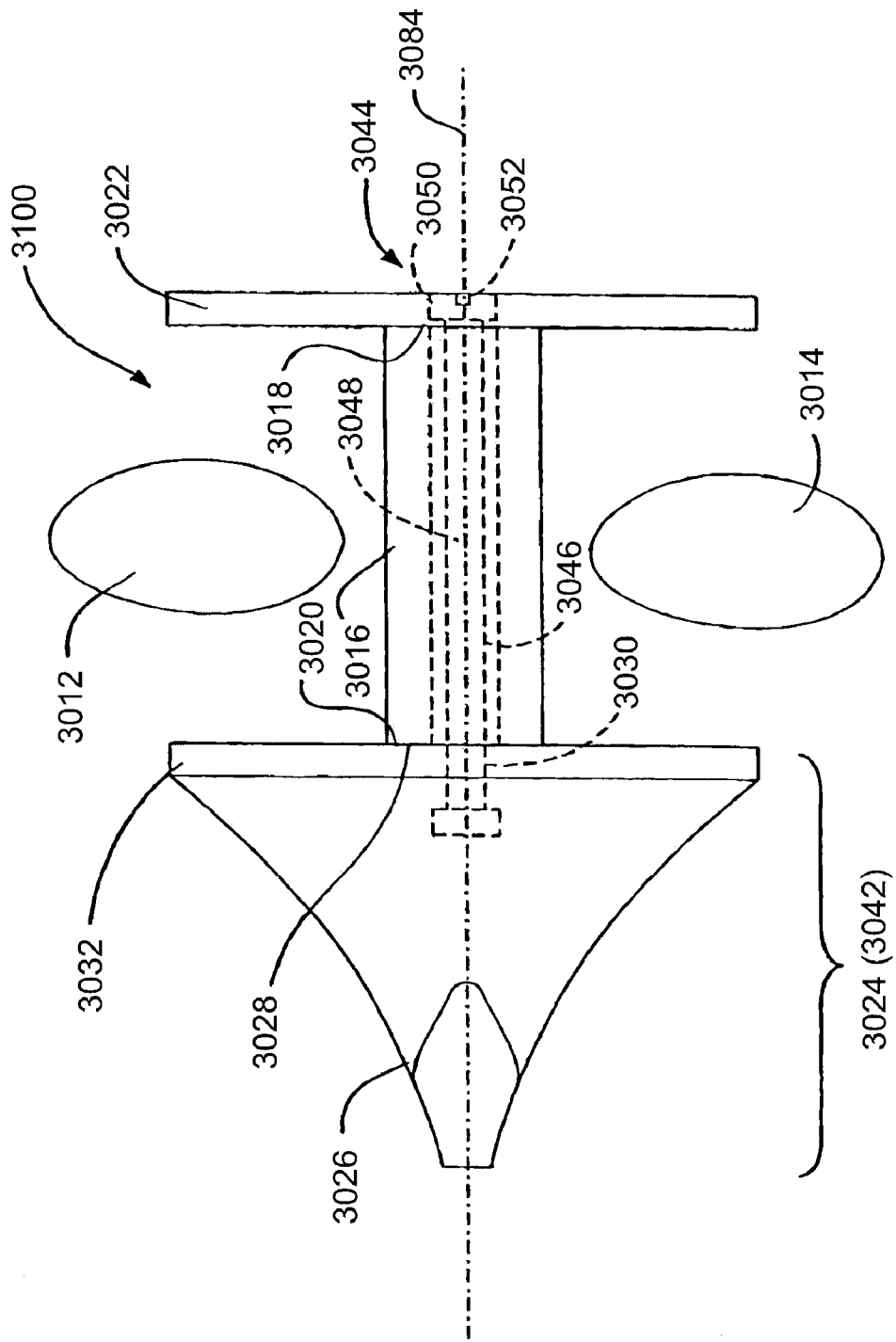

FIG. 139

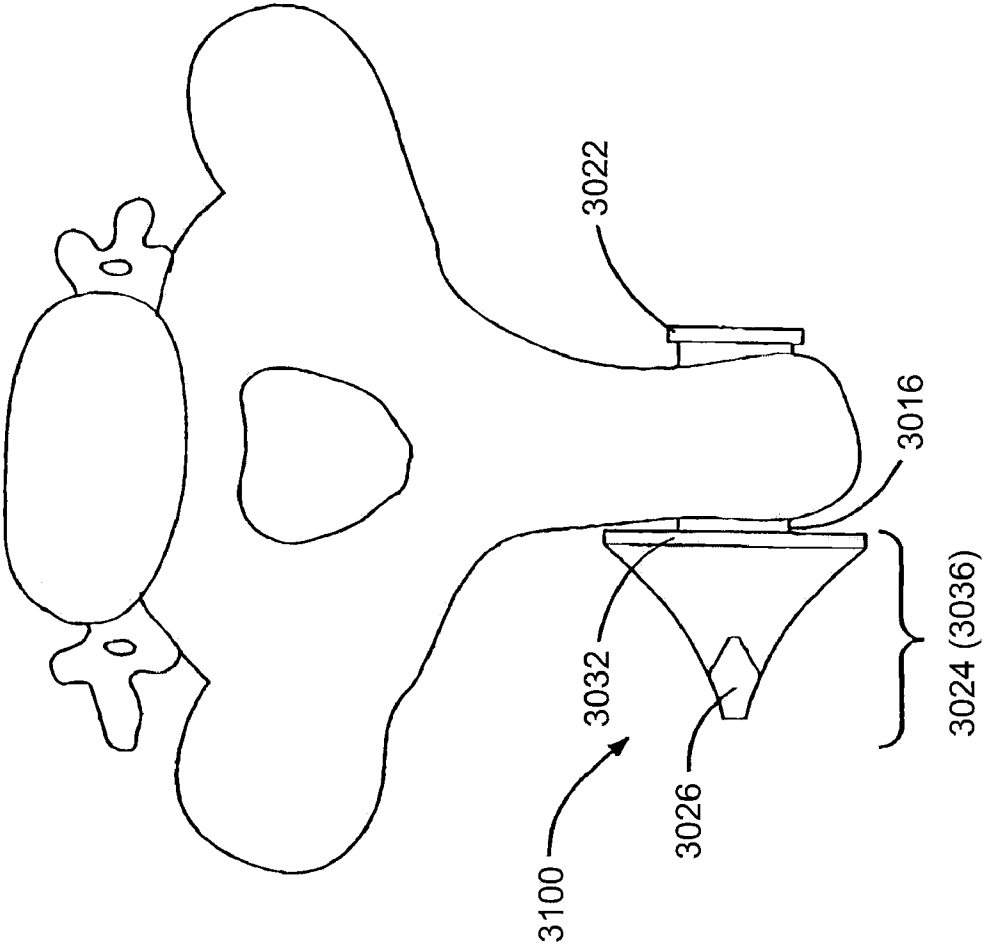

FIG. 140

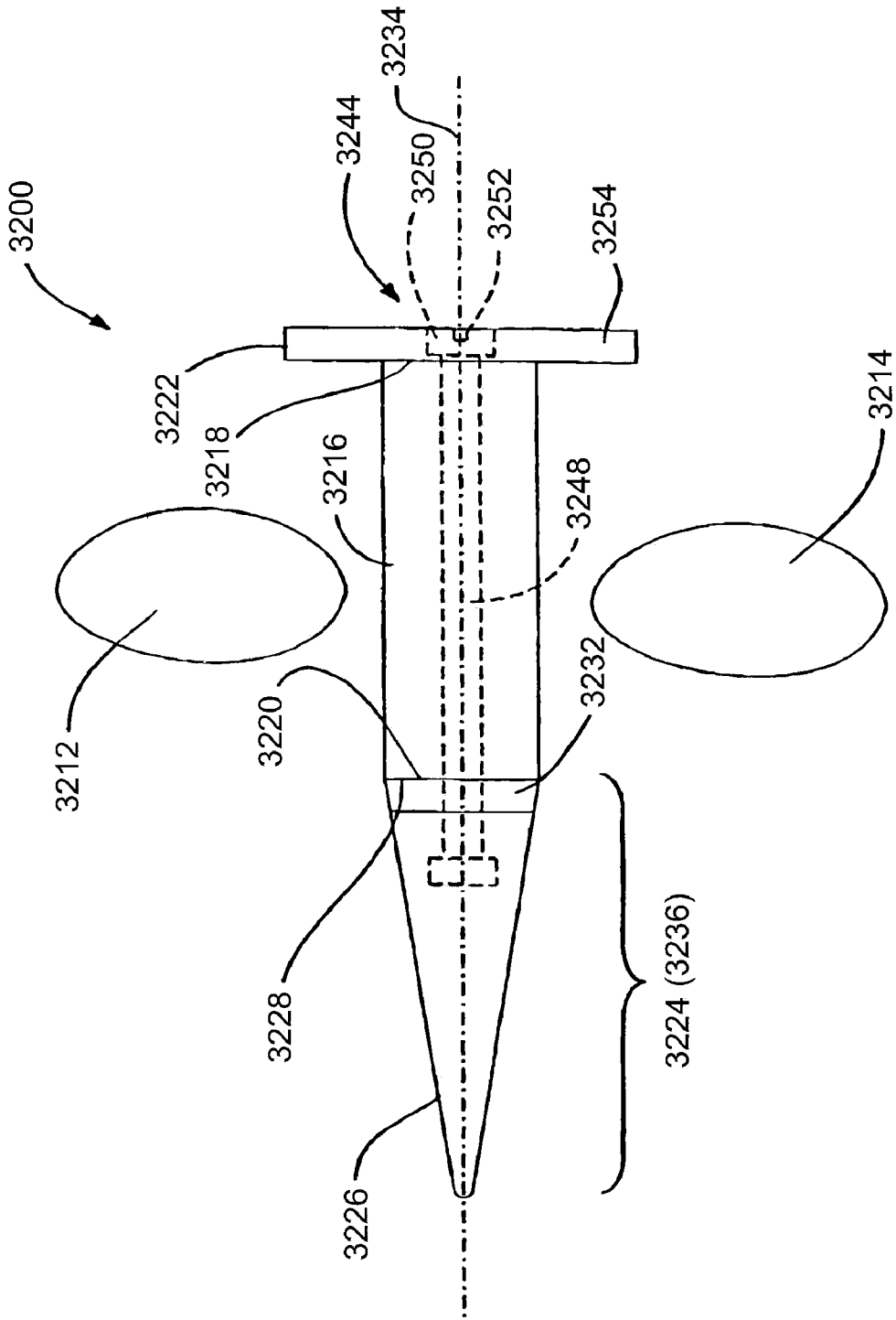

FIG. 141

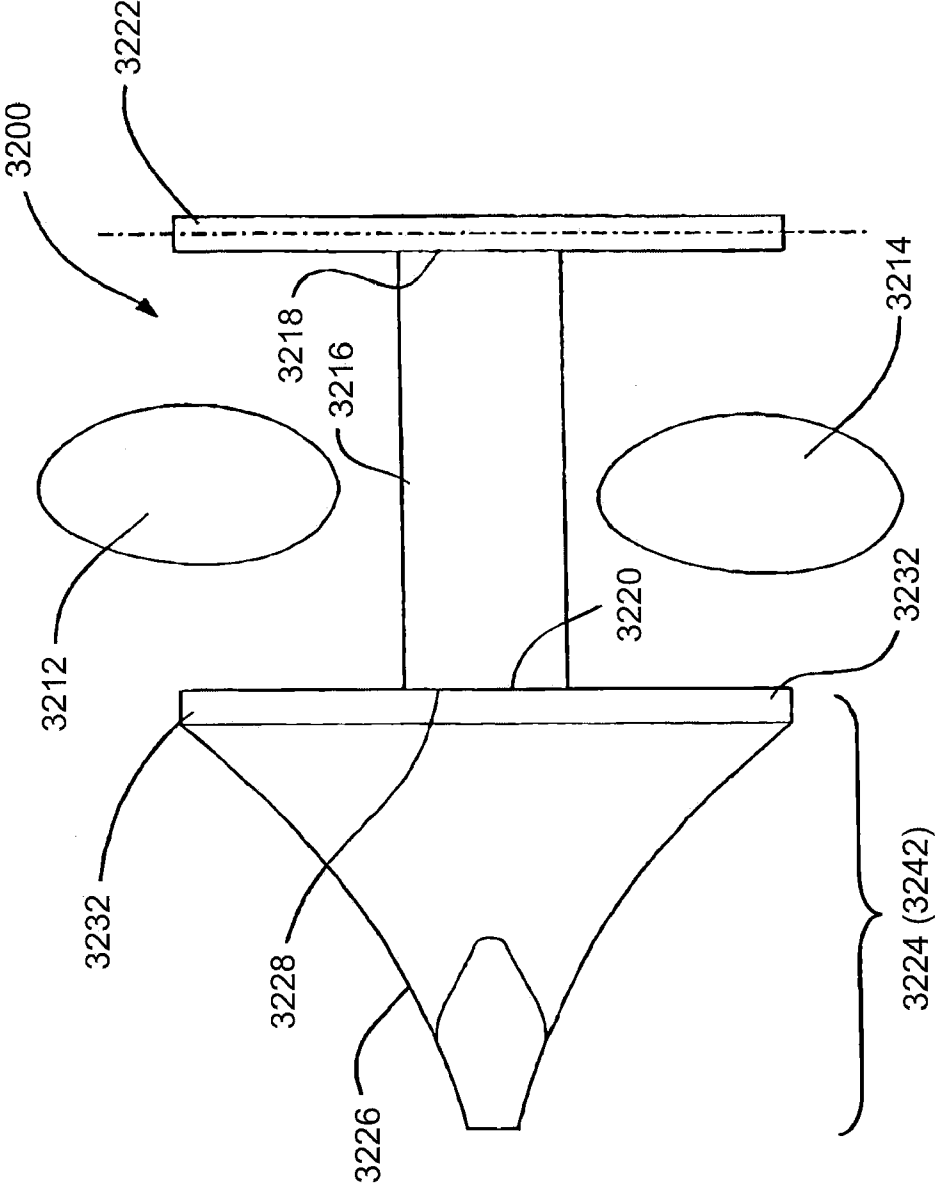

FIG. 142

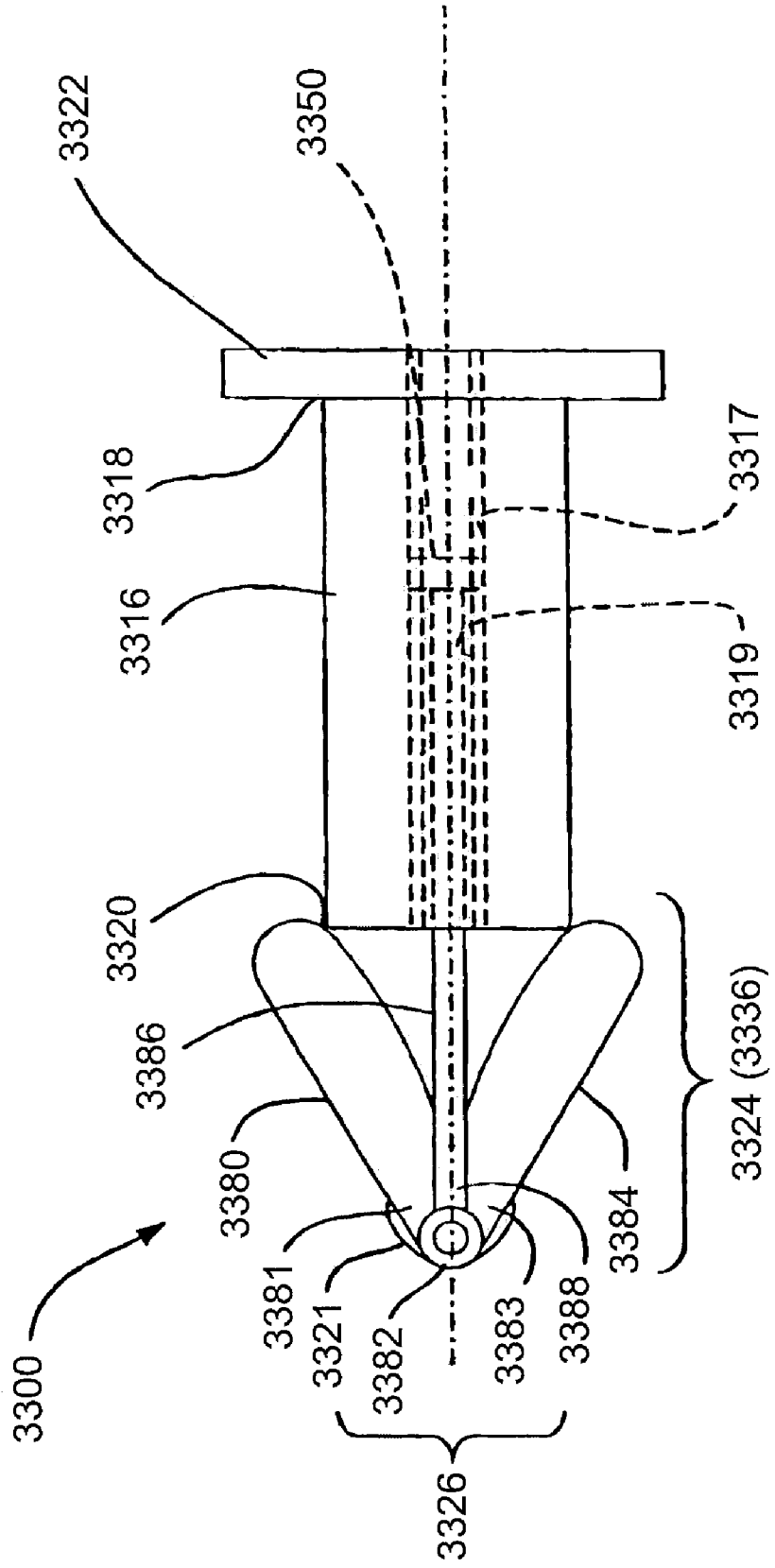

FIG. 143

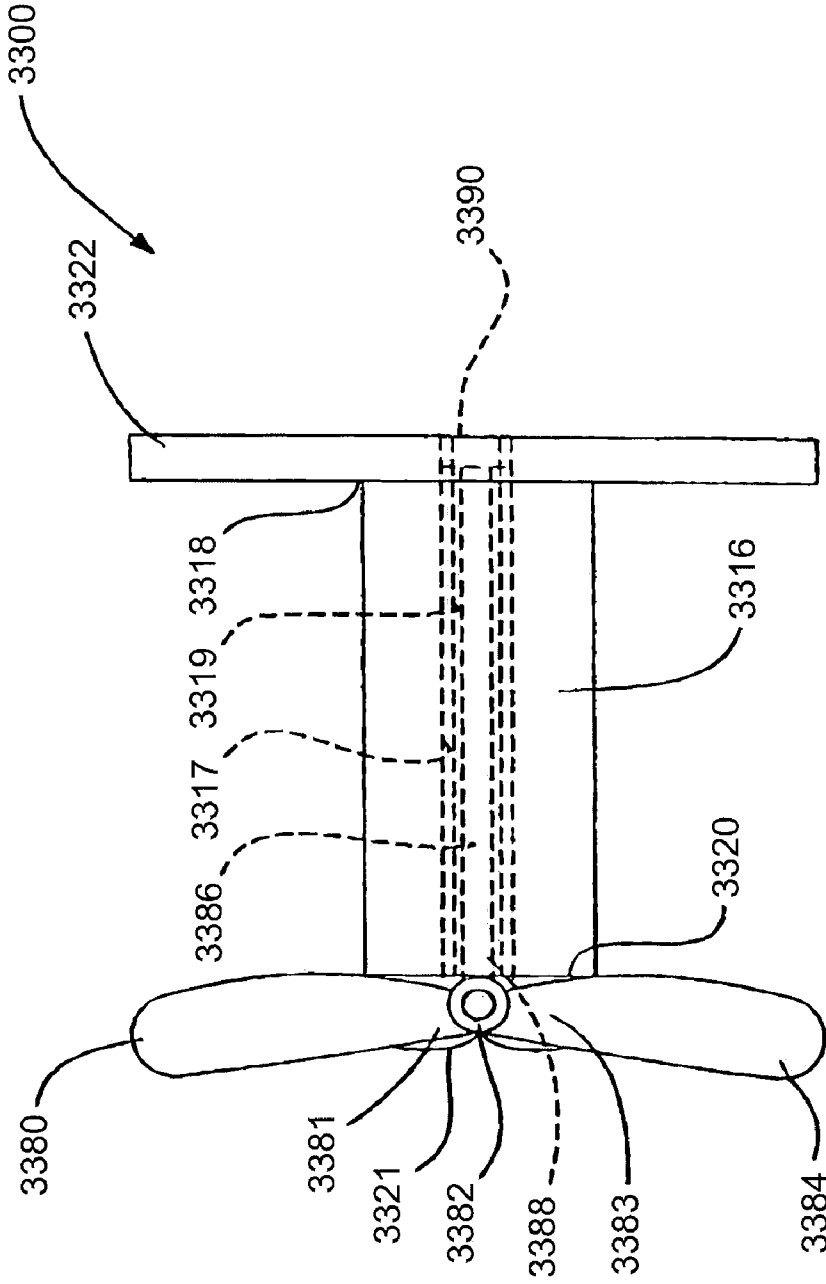

FIG. 144

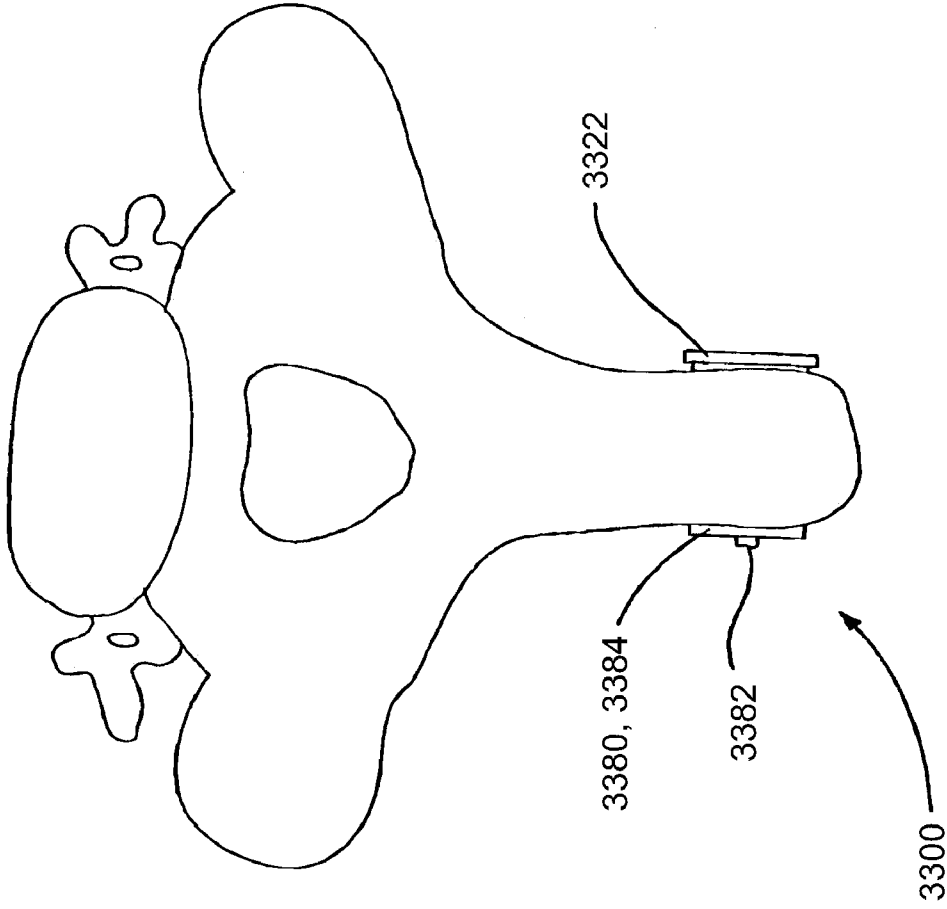

FIG. 145

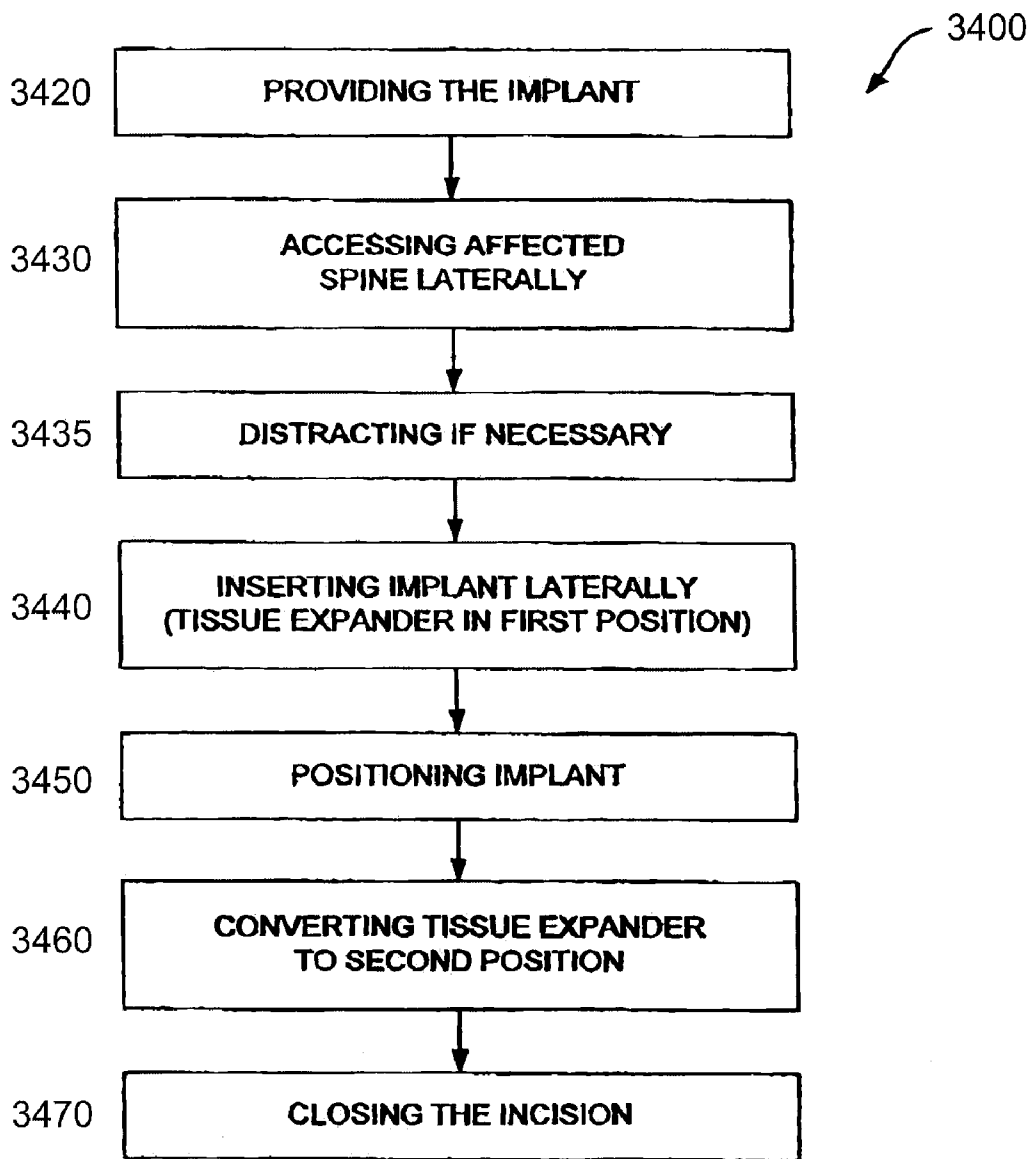

FIG. 146

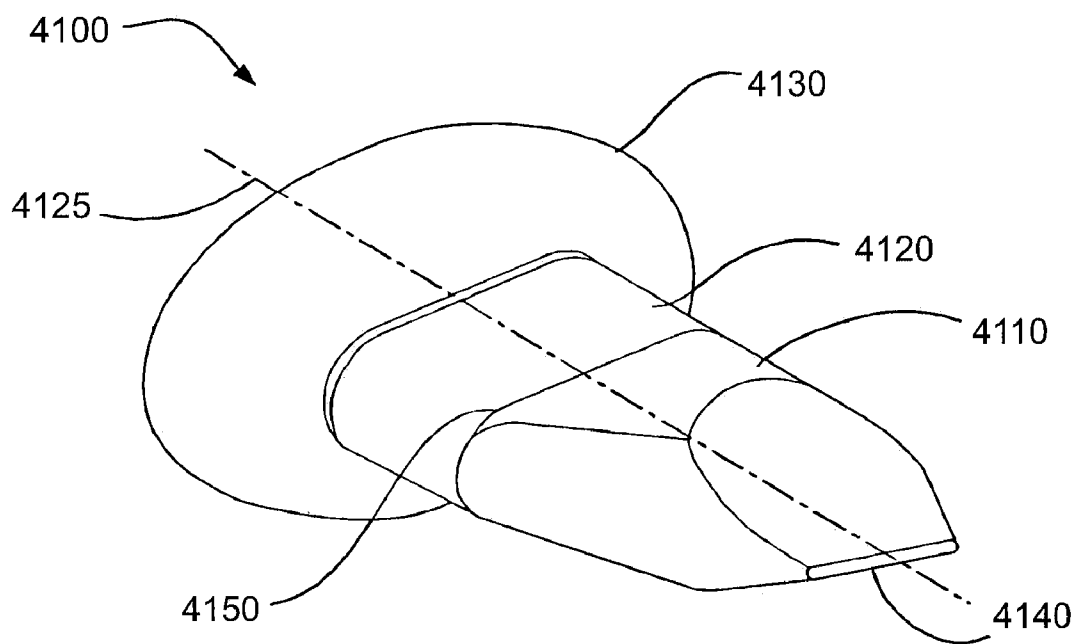

FIG. 147

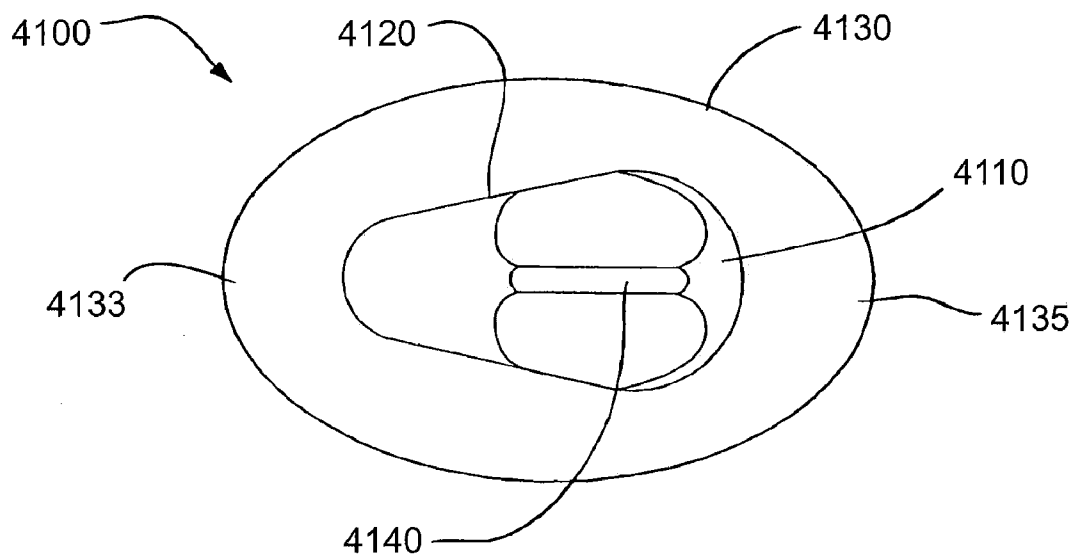

FIG. 148

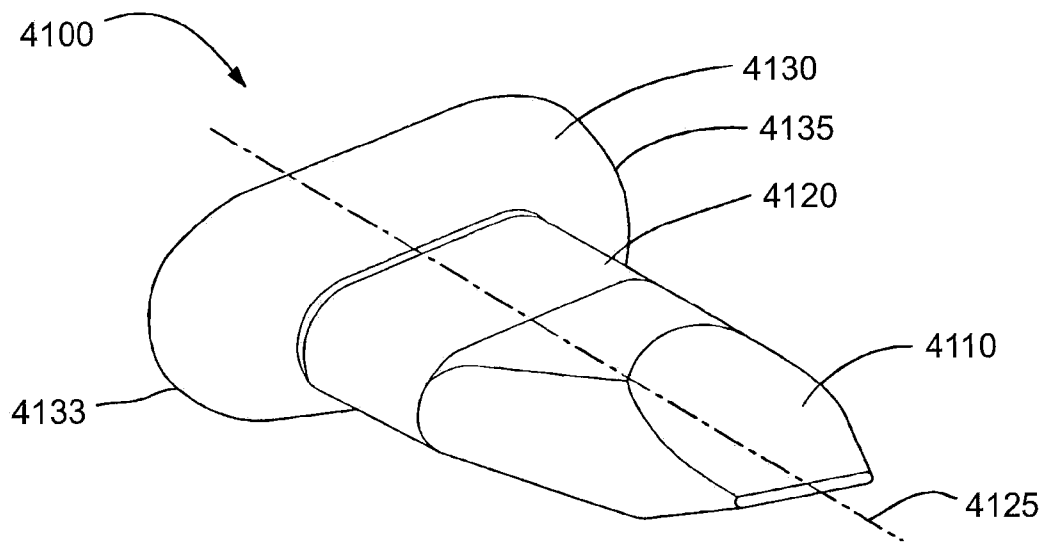

FIG. 149

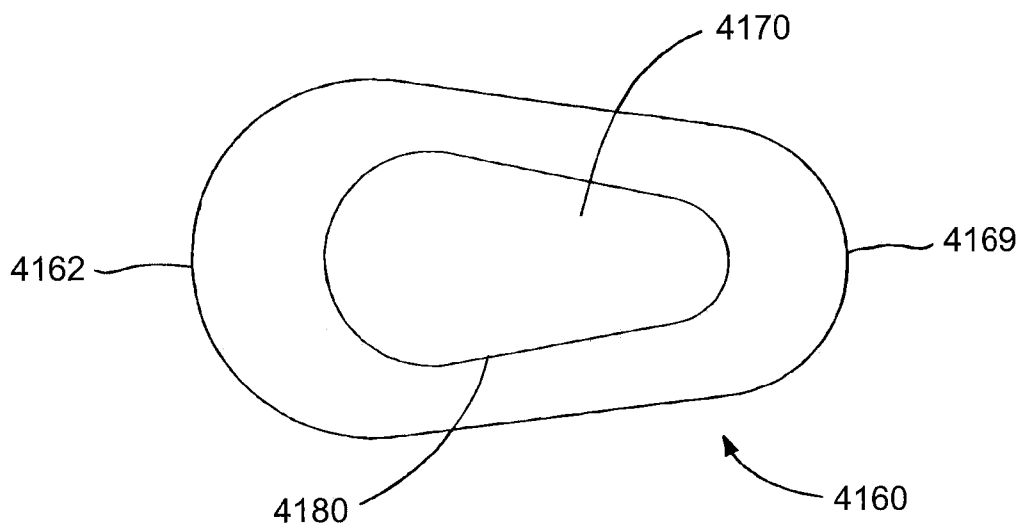

FIG. 150

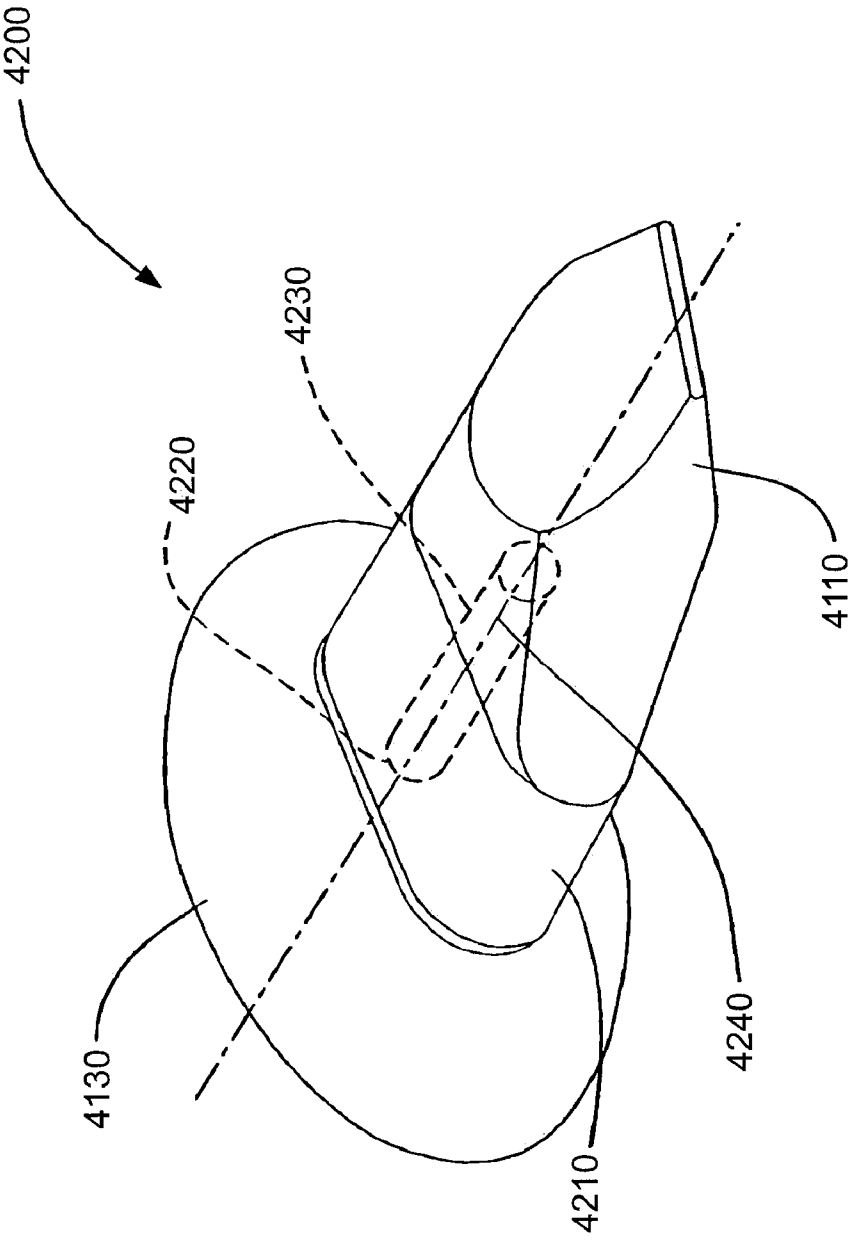

FIG. 151

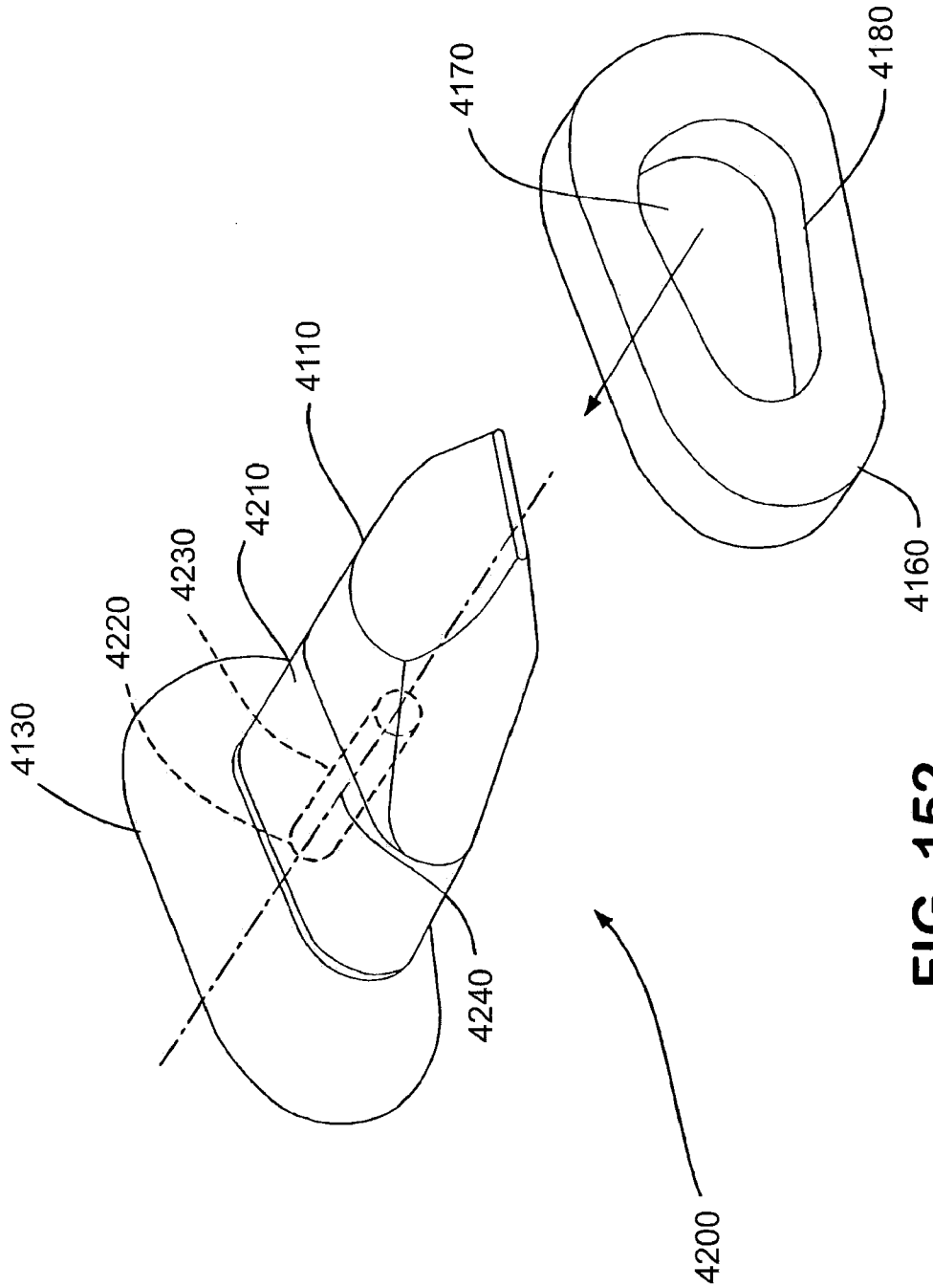

FIG. 152

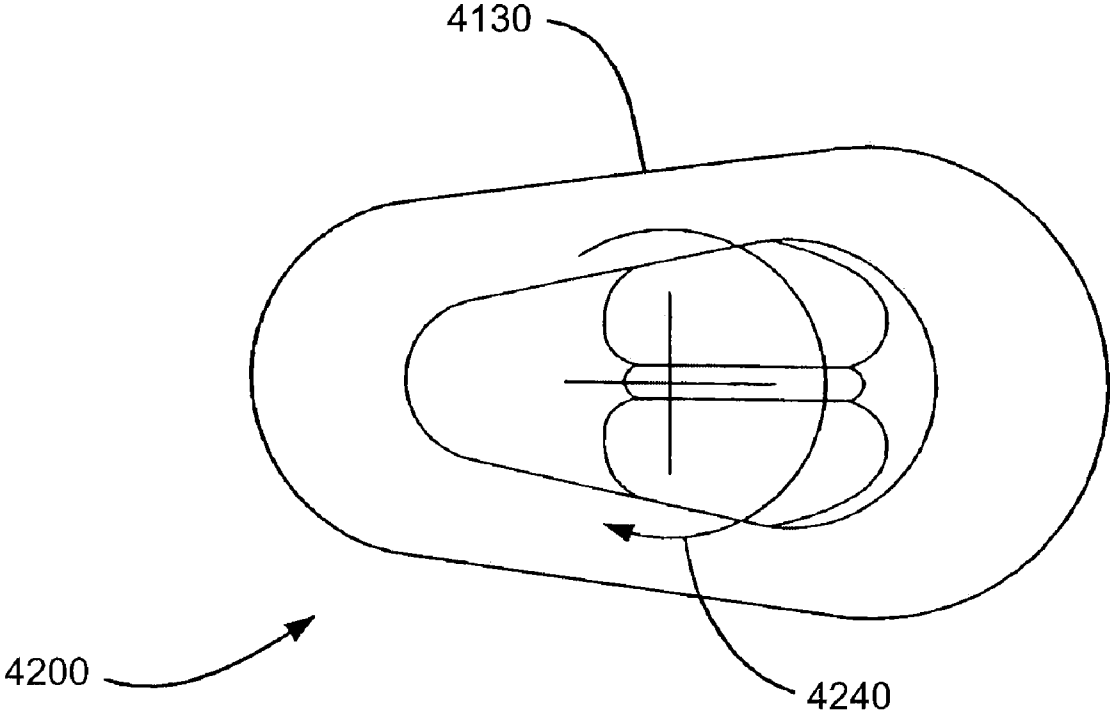

FIG. 153

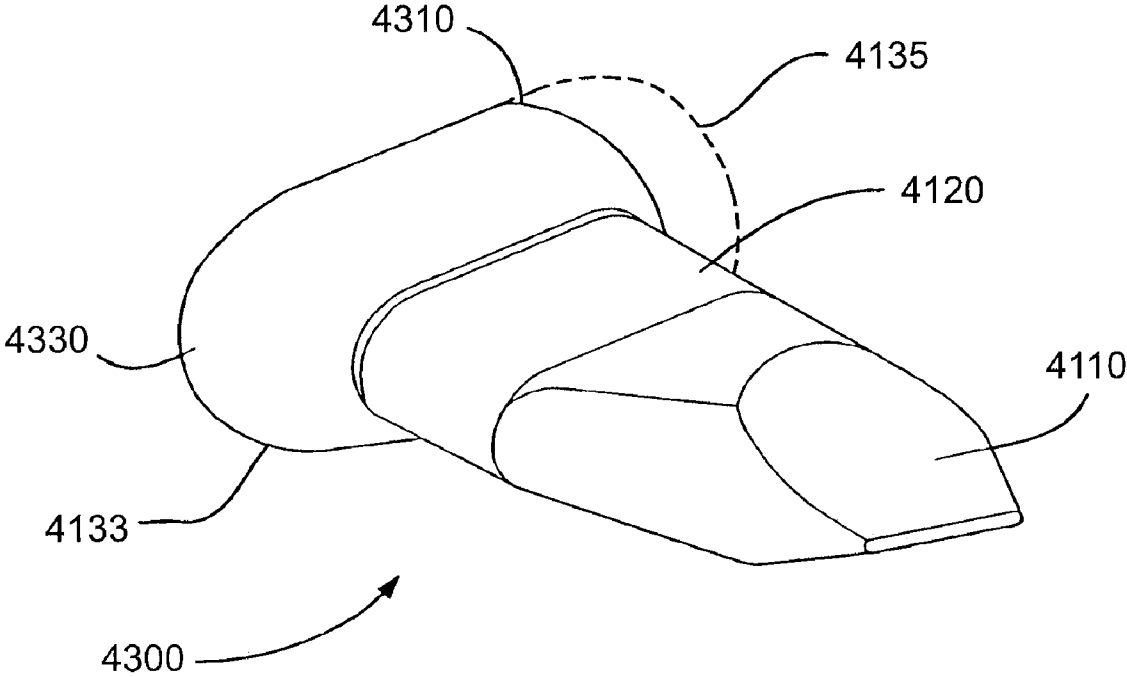

FIG. 154

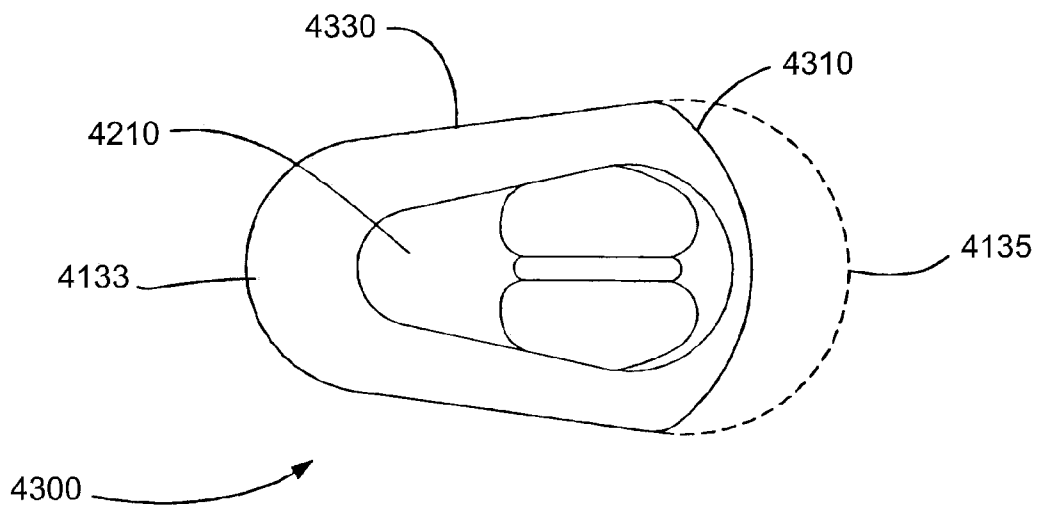

FIG. 155A

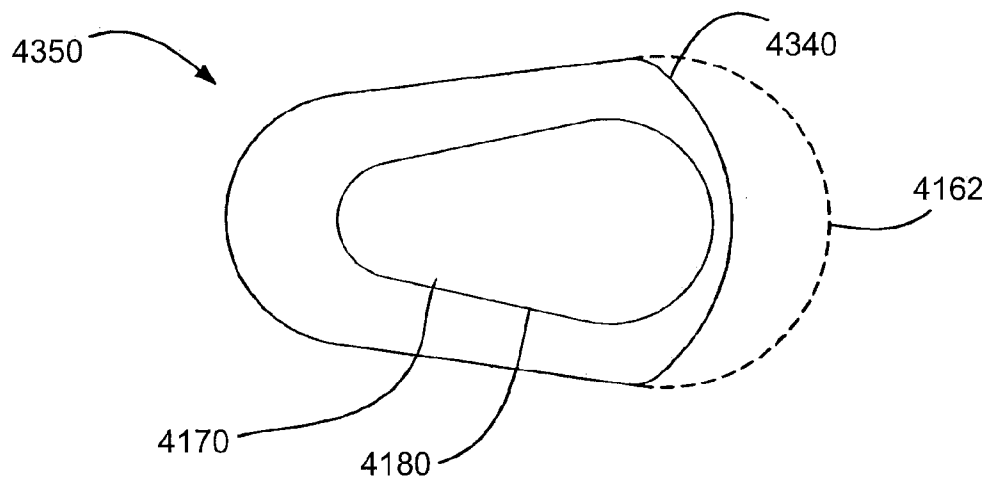

FIG. 155B

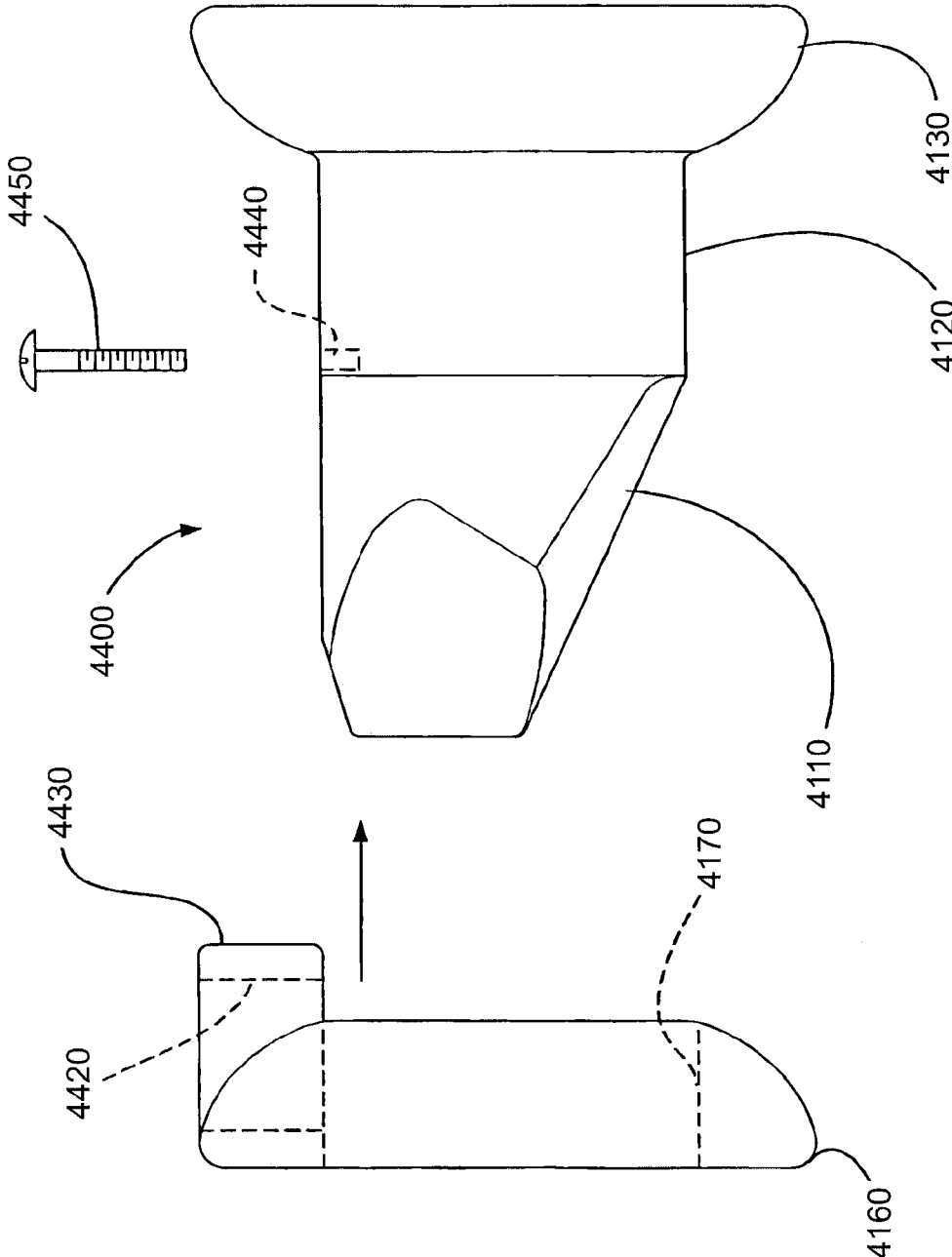

FIG. 156

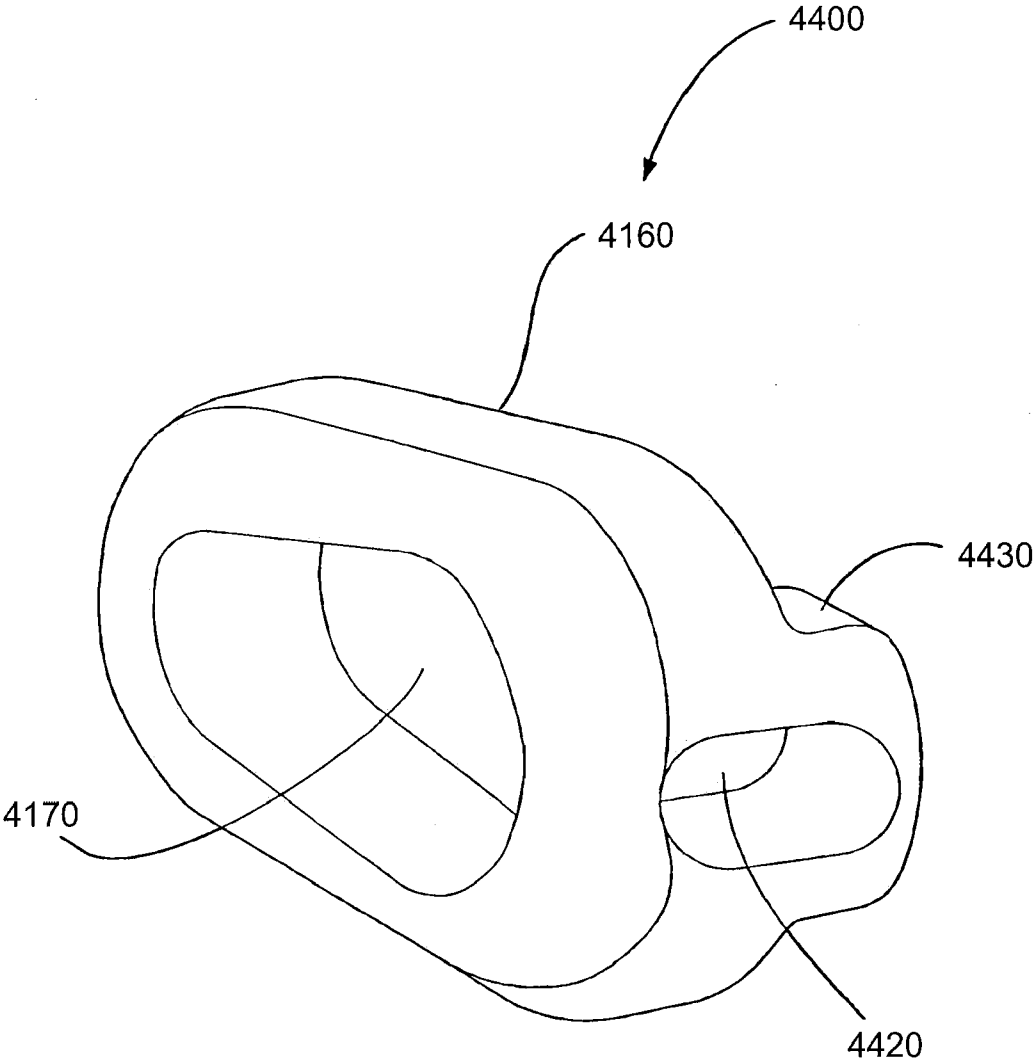

FIG. 157

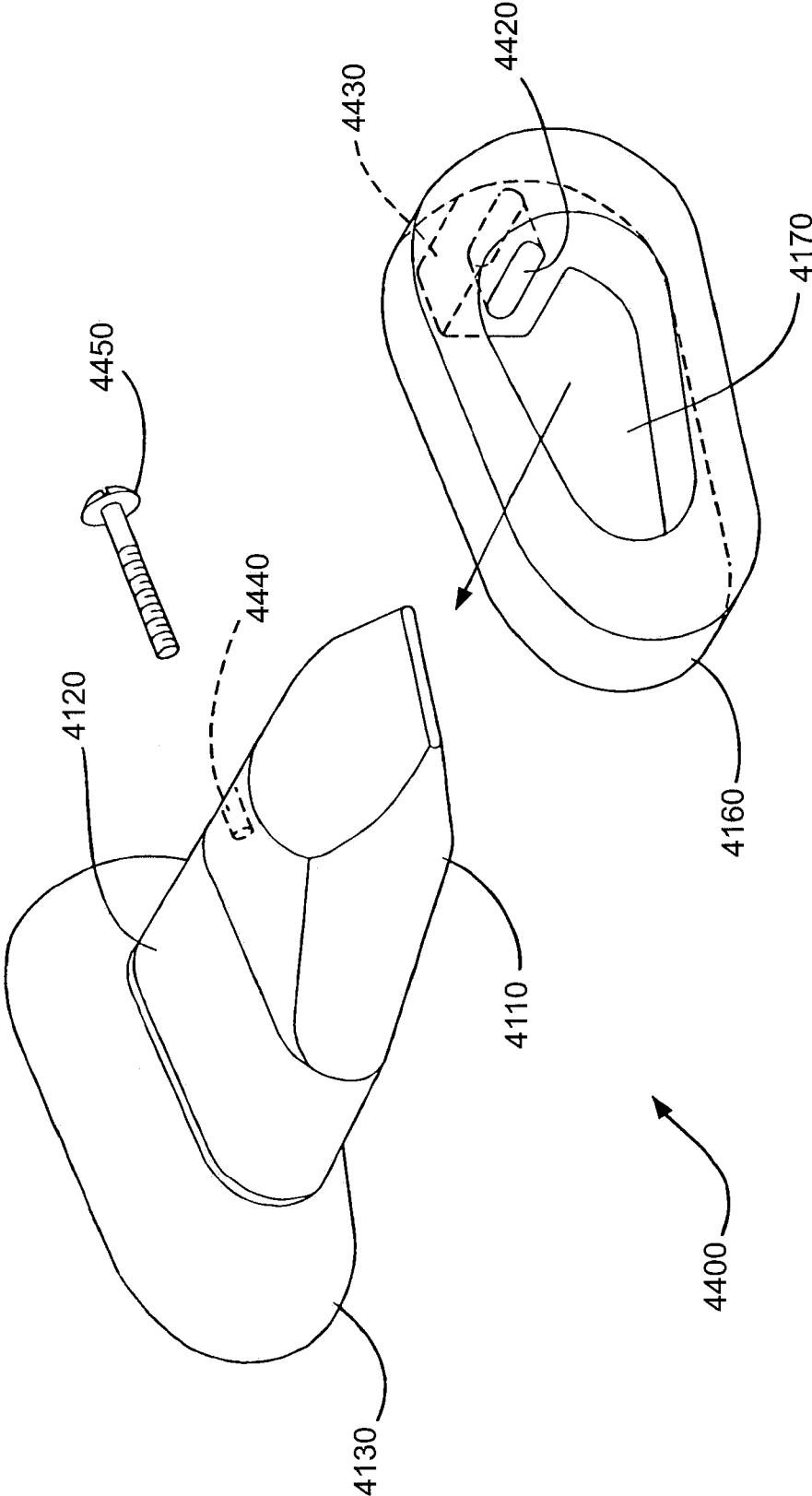

FIG. 158

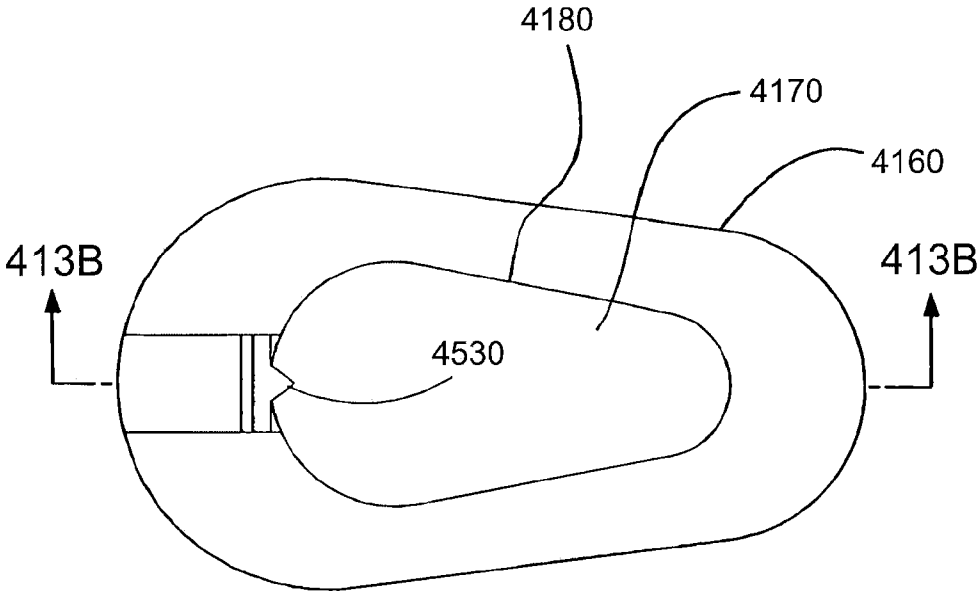

FIG. 159A

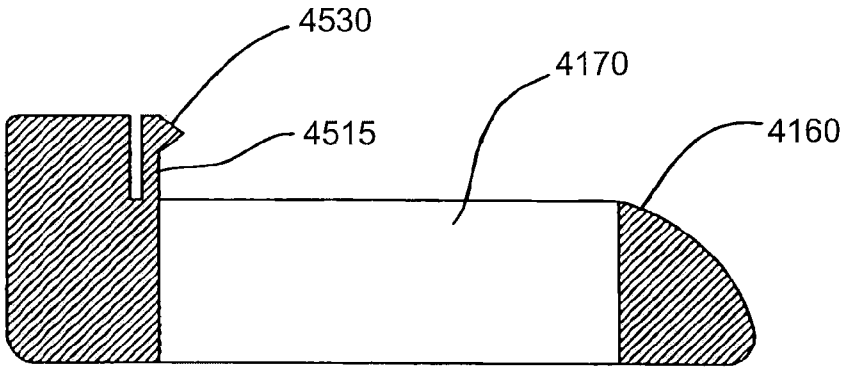

FIG. 159B

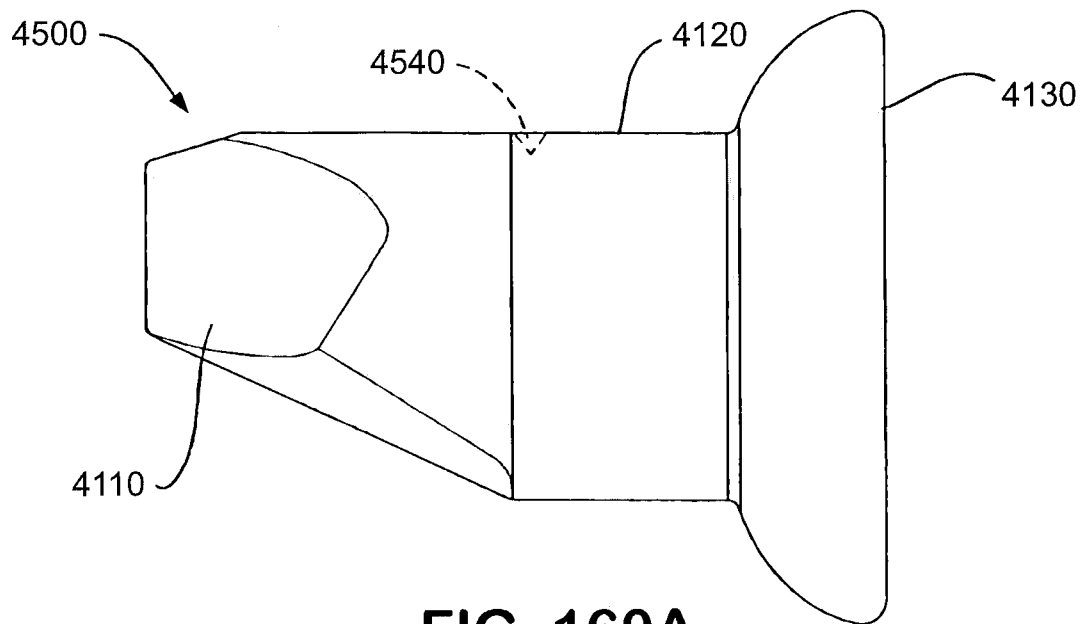

FIG. 160A

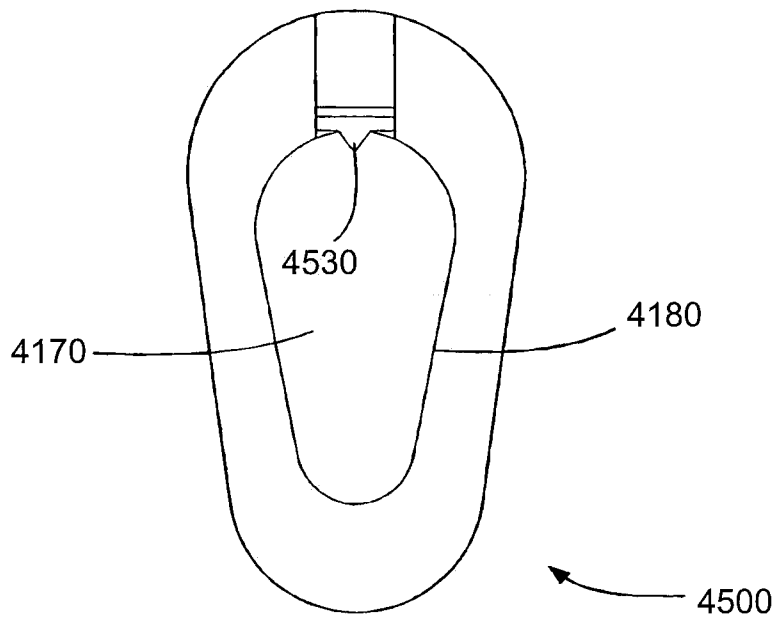

FIG. 160B

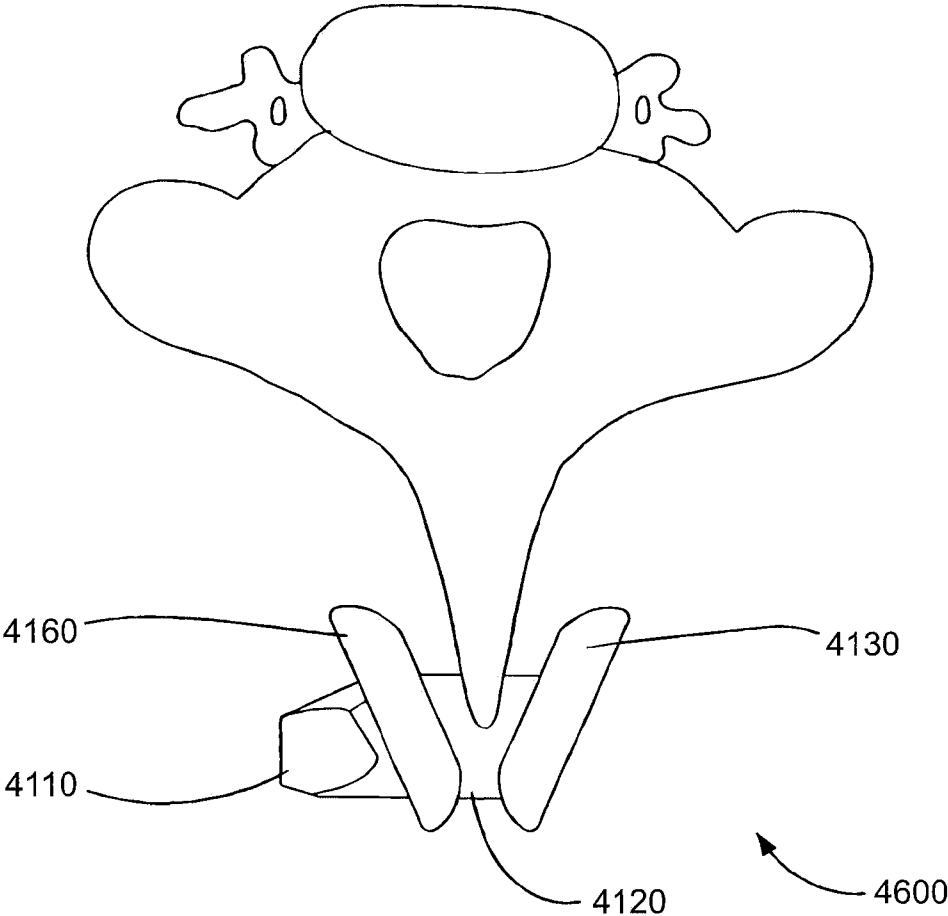

FIG. 161A

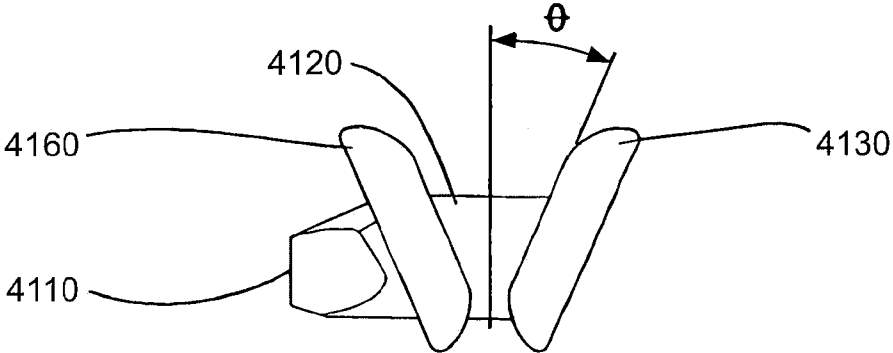

FIG. 161B

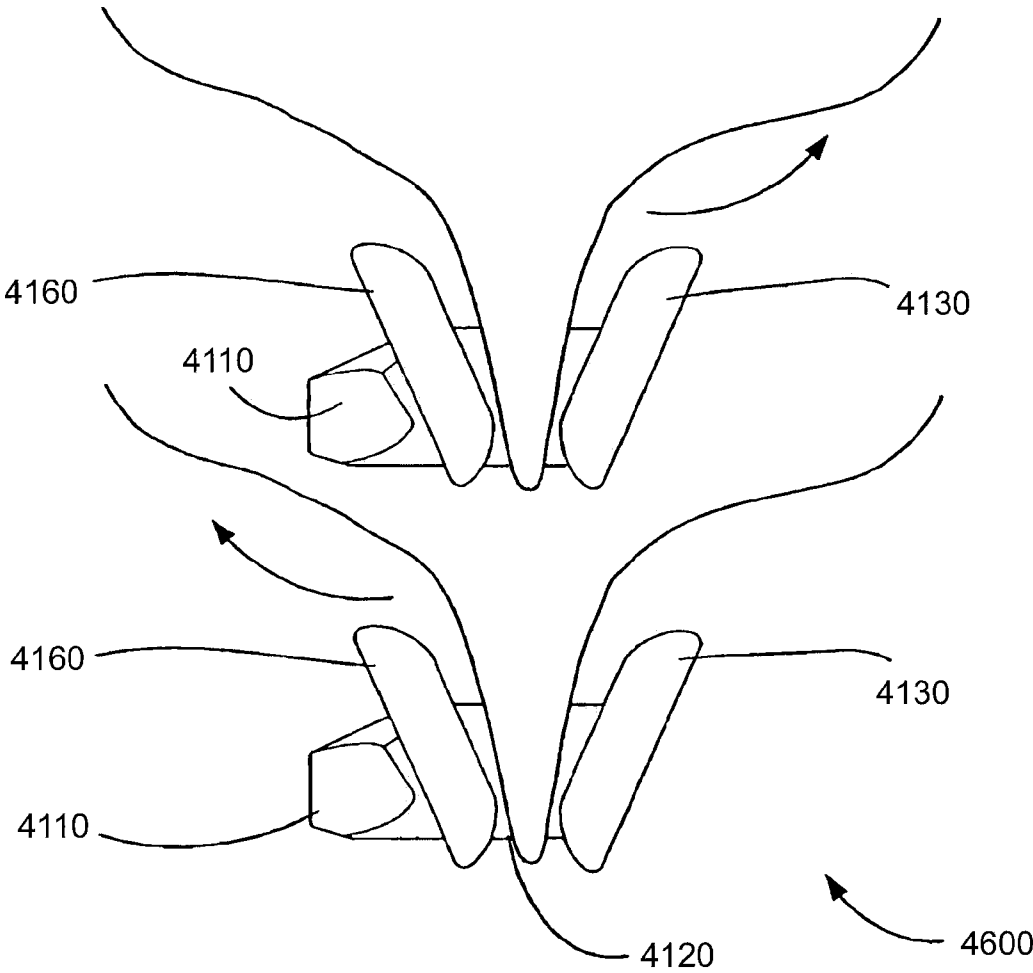

FIG. 162

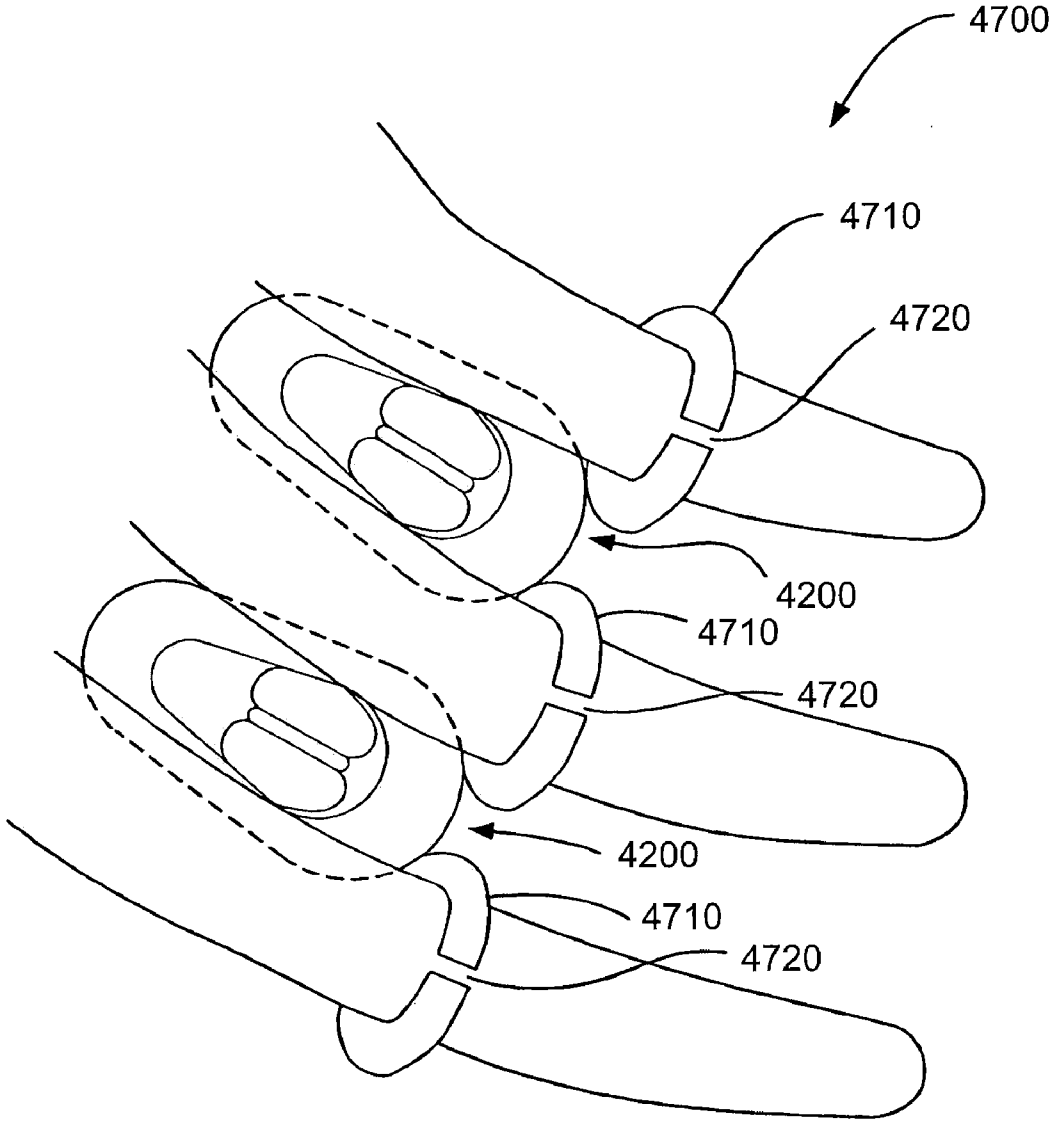

FIG. 163

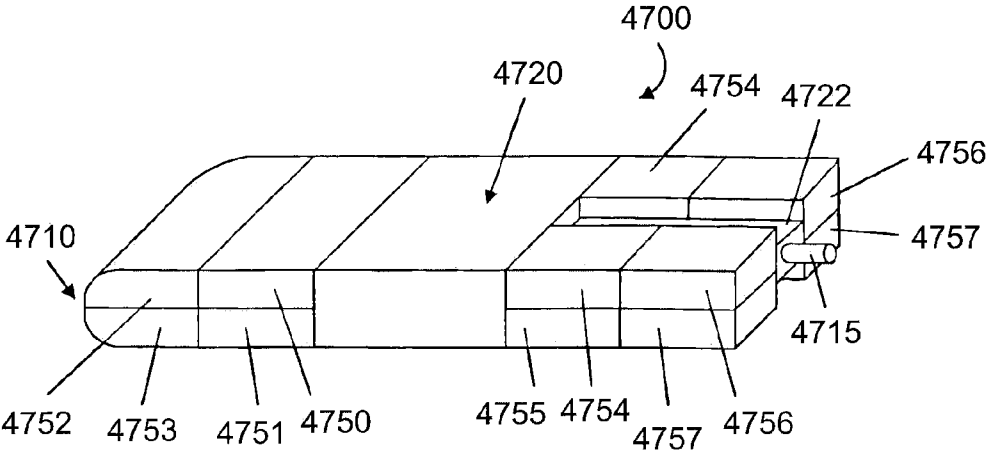

FIG. 164A

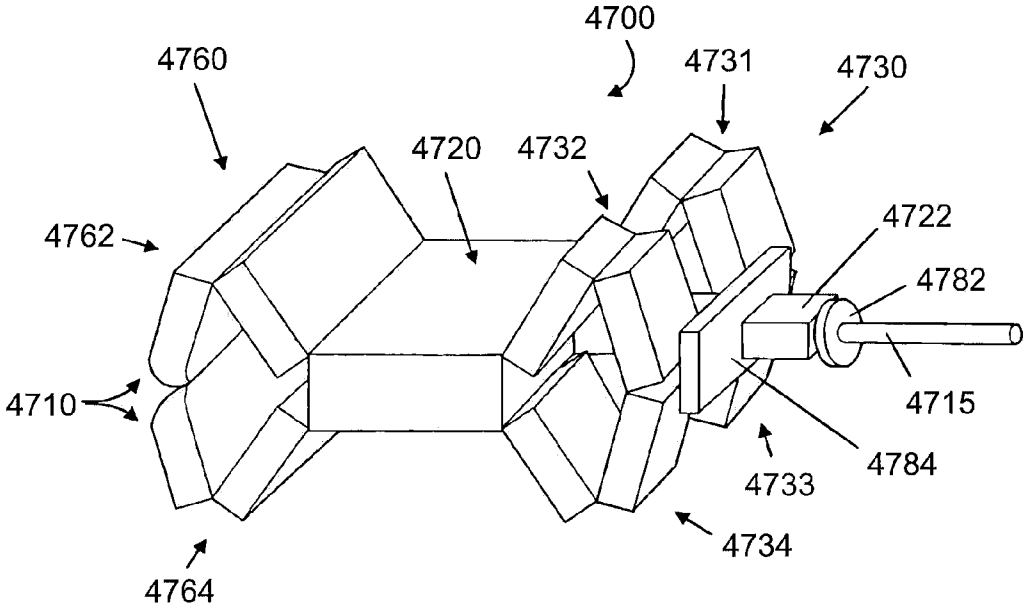

FIG. 164B

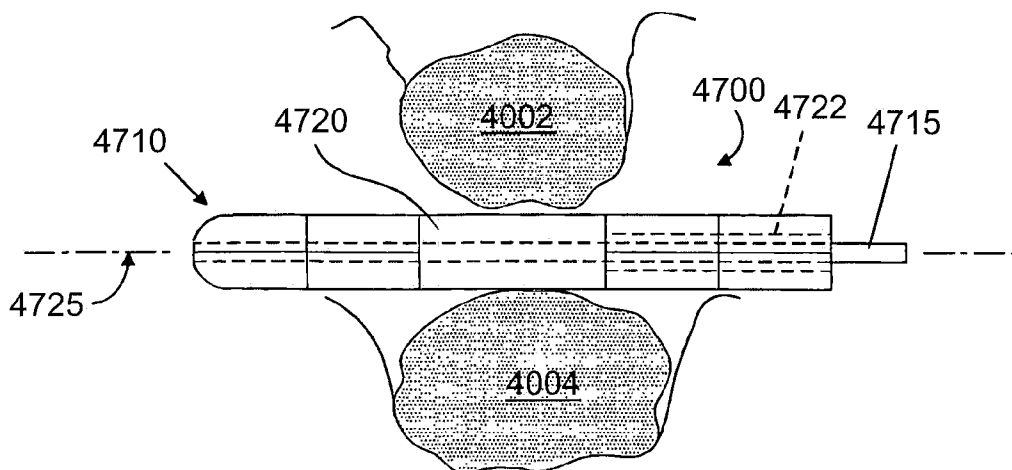

FIG. 165A

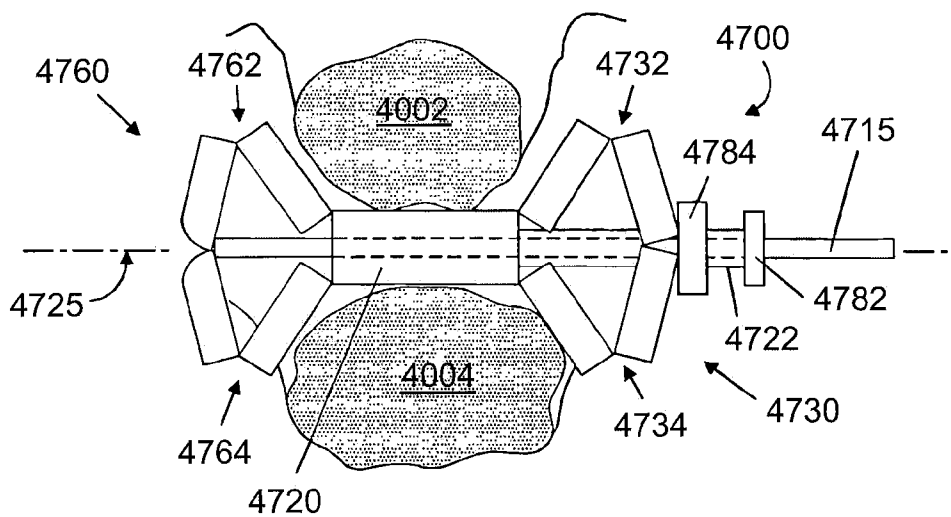

FIG. 165B

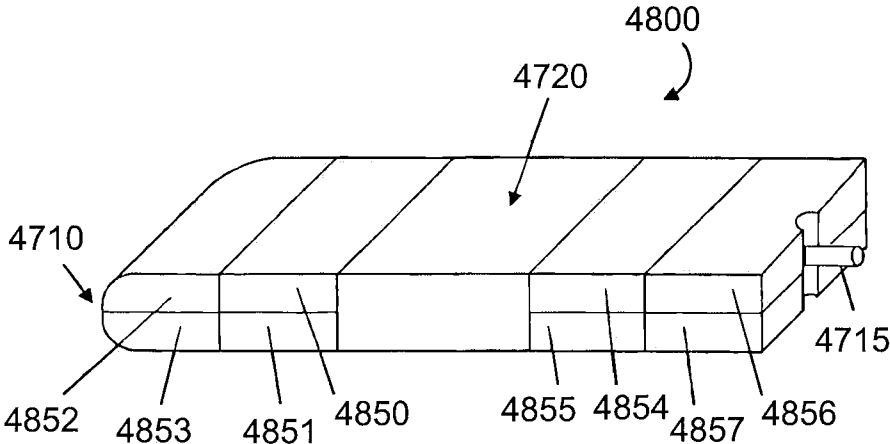

FIG. 166A

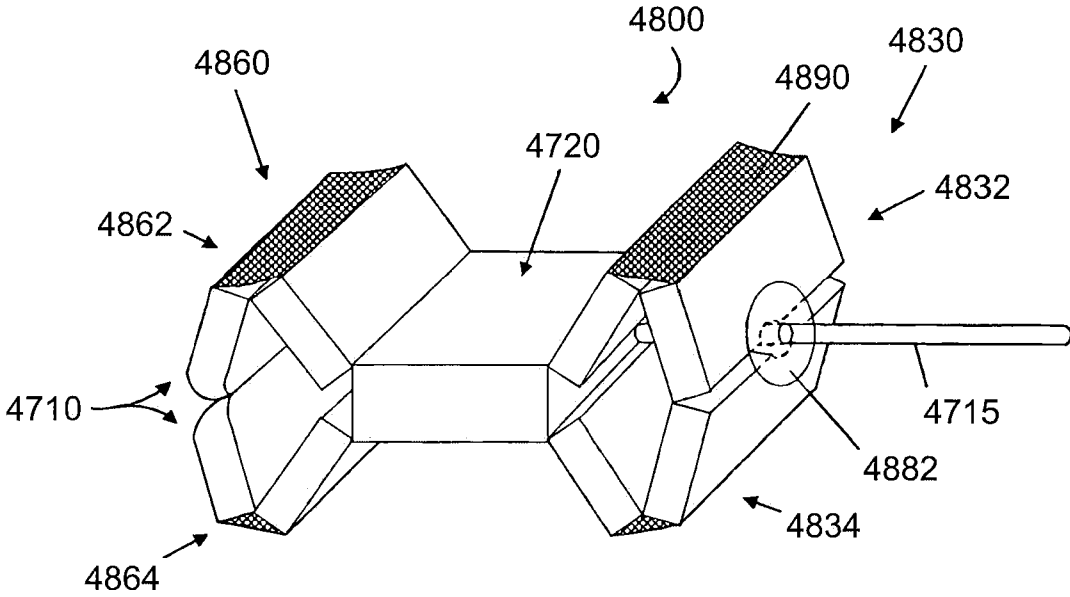

FIG. 166B

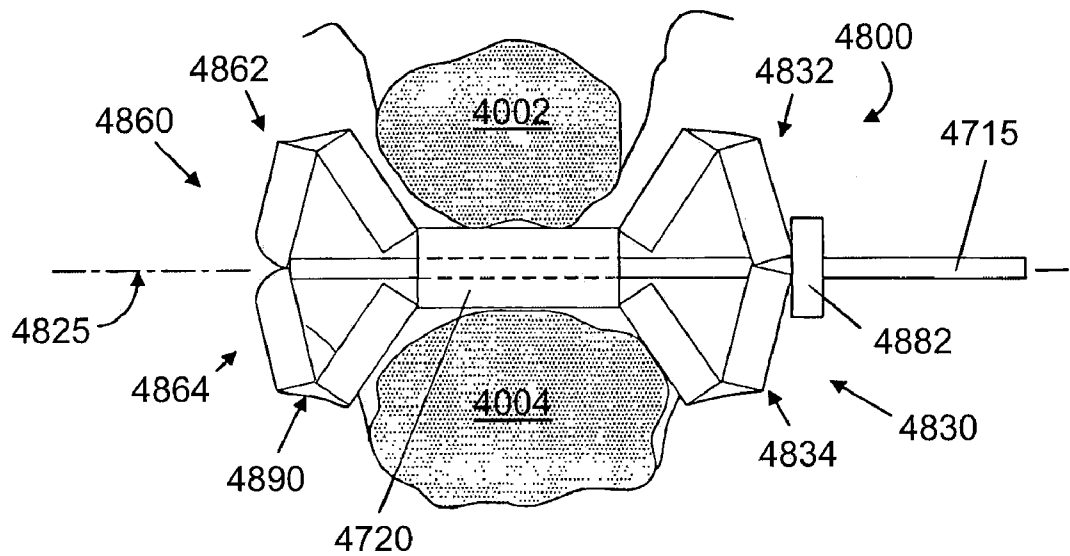

FIG. 167

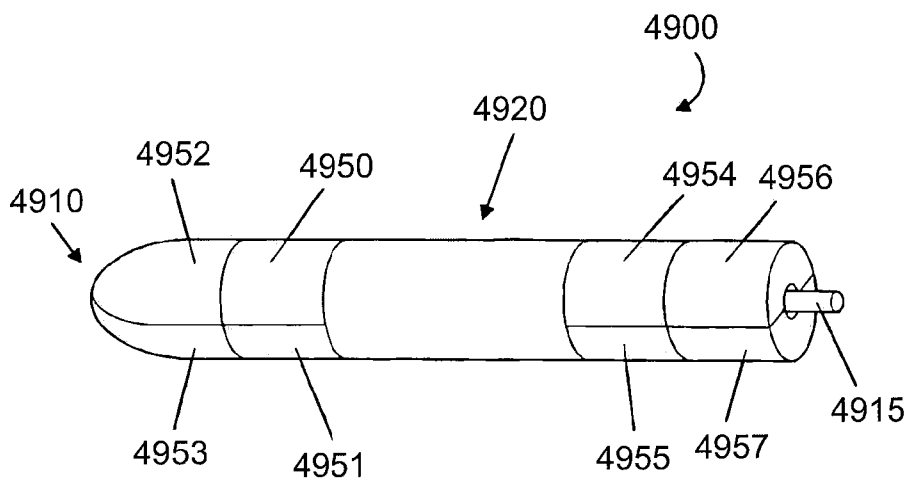

FIG. 168A

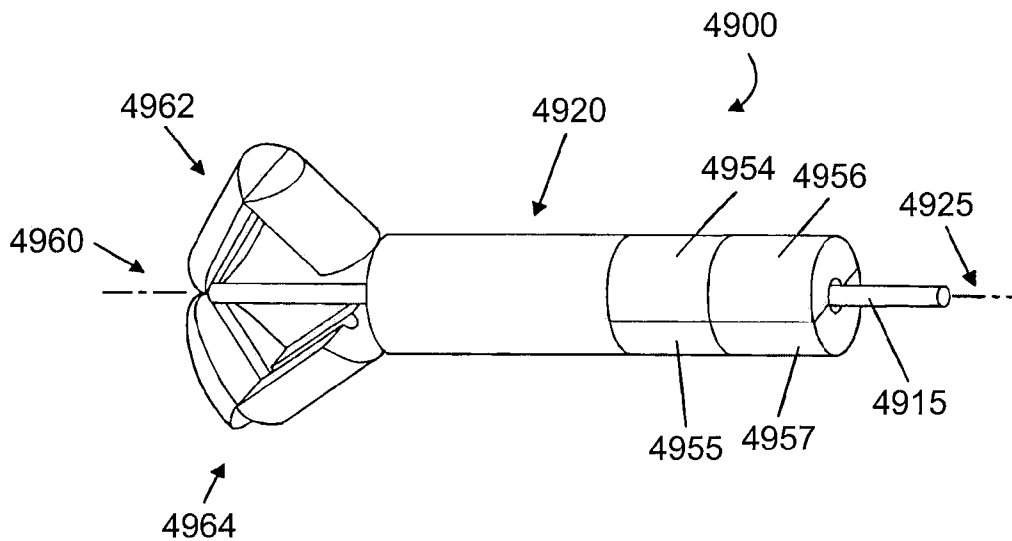

FIG. 168B

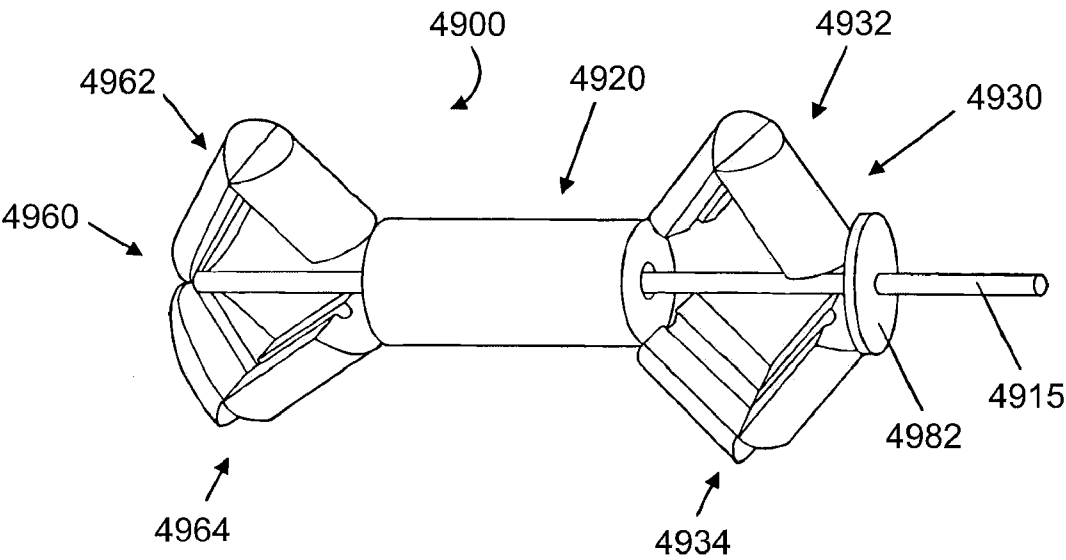

FIG. 168C

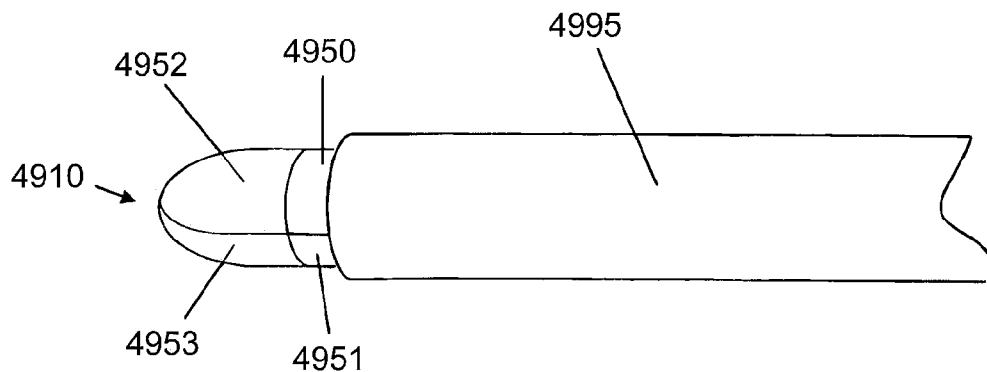

FIG. 169A

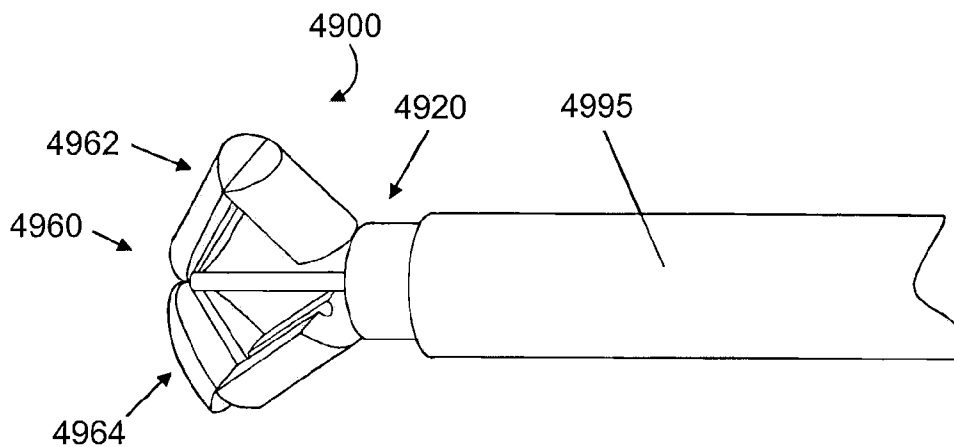

FIG. 169B

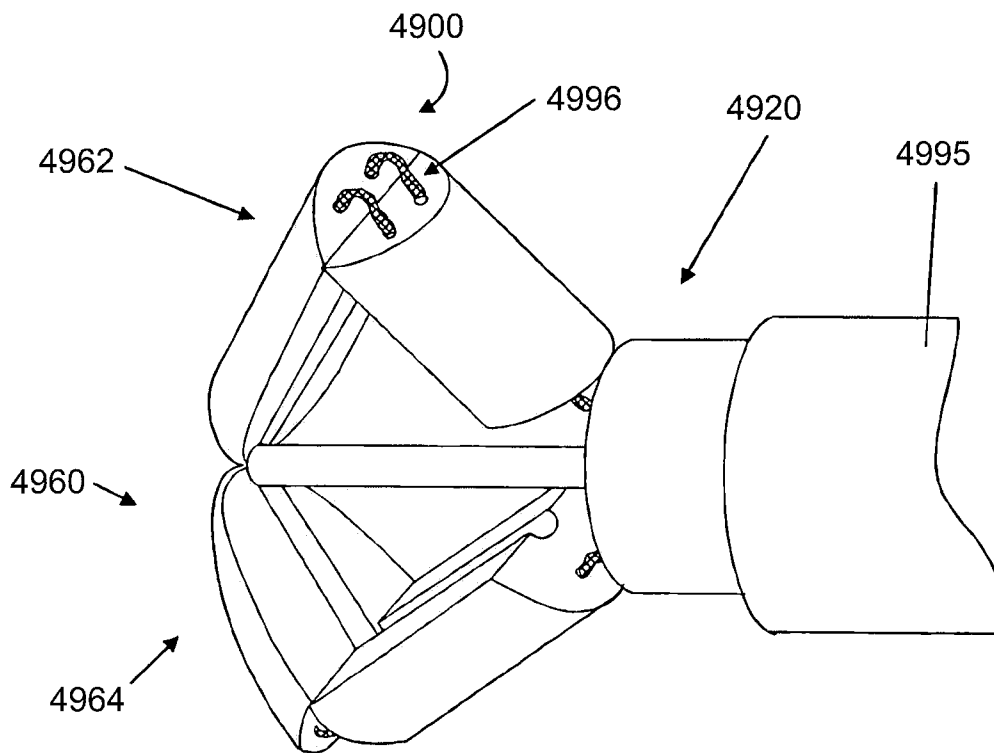

FIG. 169C

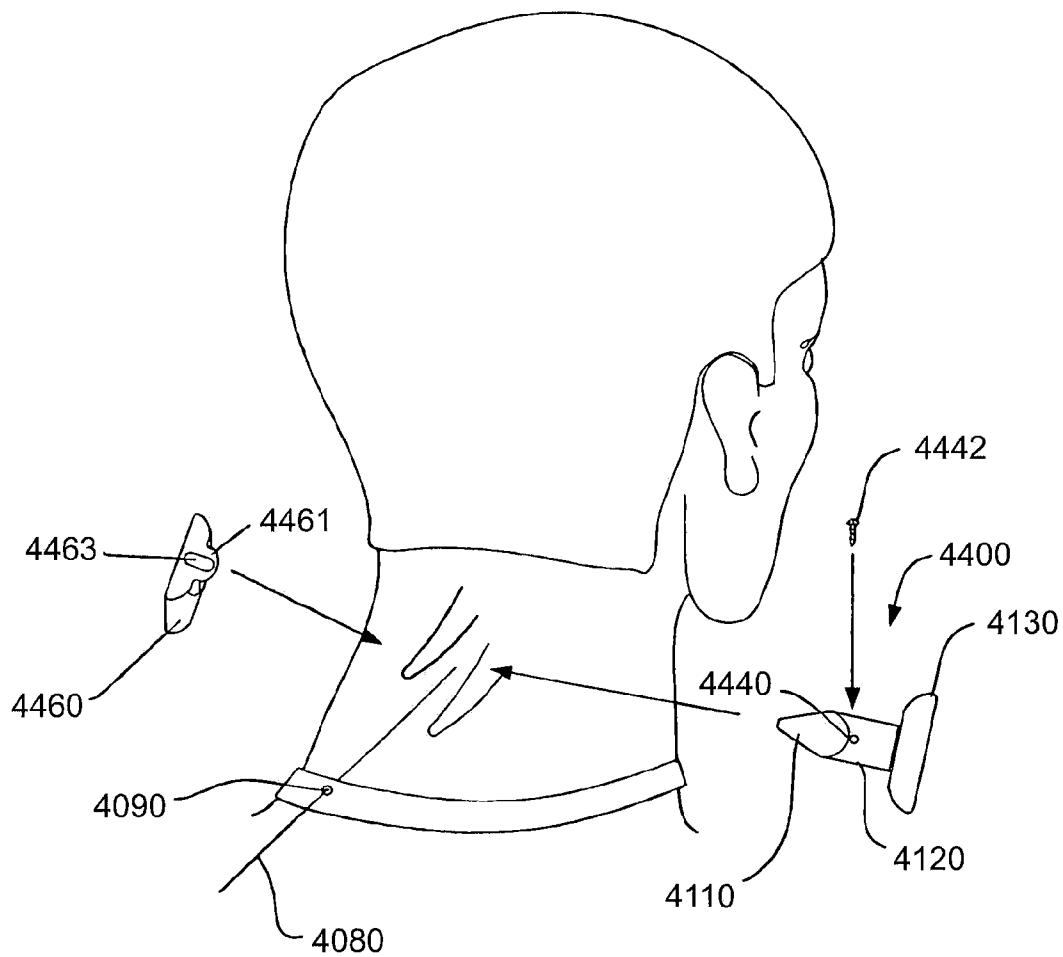

FIG. 170

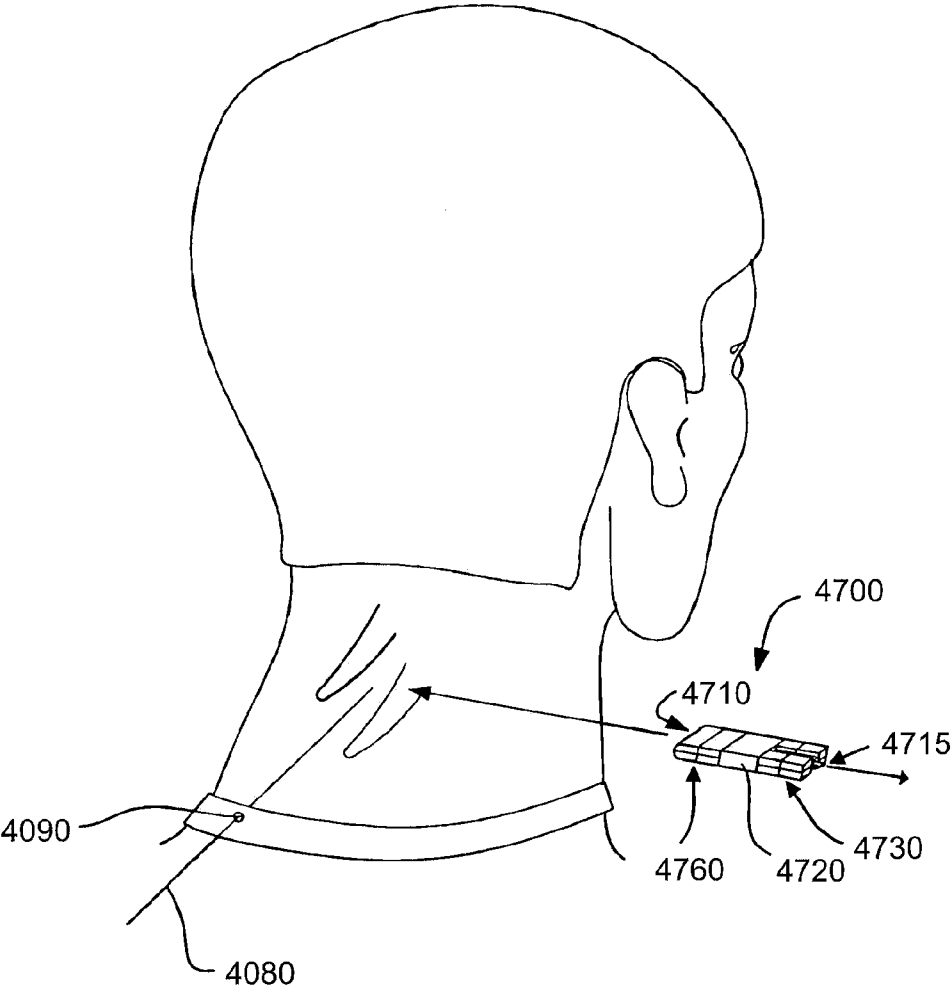

FIG. 171

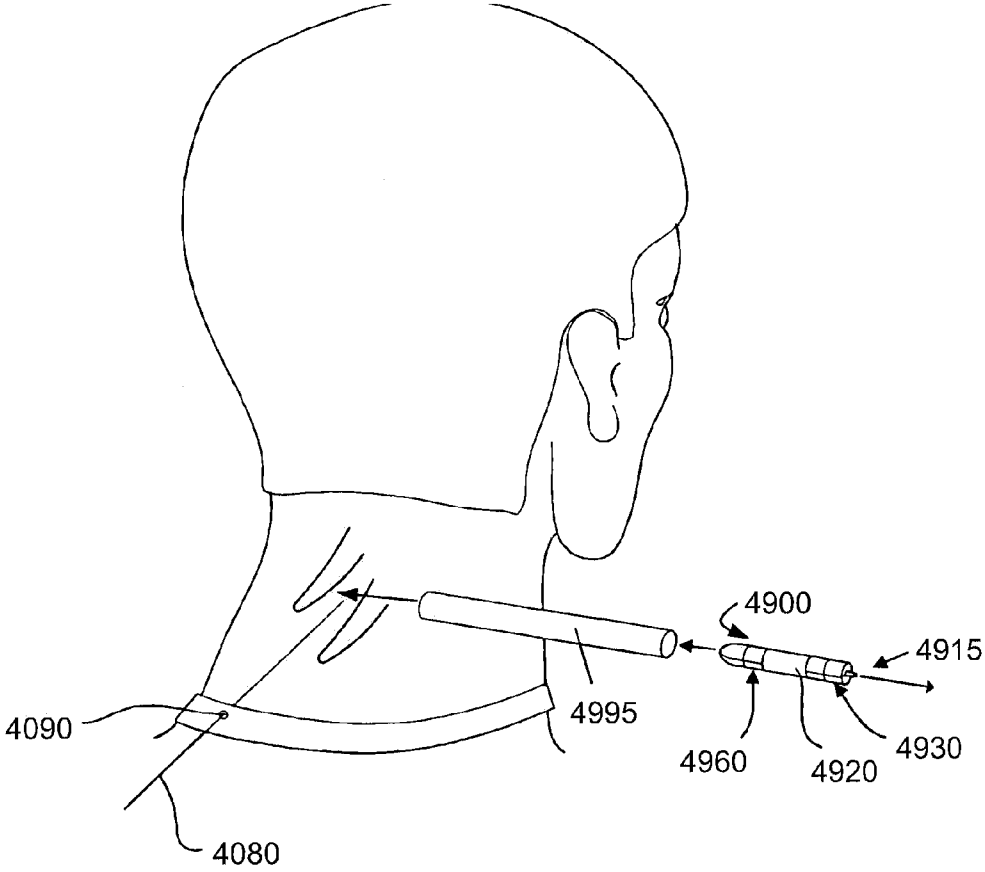

FIG. 172

SPINE DISTRACTION IMPLANT

CROSS-REFERENCES TO RELATED APPLICATIONS

[0001] The present application is a continuation-in-part of U.S. patent application Ser. No. 11/092,862, filed on Mar. 29, 2005; is a divisional of U.S. patent application Ser. No. 09/842,819, filed on Apr. 26, 2001, now issued as U.S. Pat. No. 7,201,751; which is a continuation-in-part of U.S. patent application Ser. No. 09/579,039, filed on May 26, 2000, now U.S. Pat. No. 6,451,019; which is a continuation-in-part of U.S. patent application Ser. No. 09/473,173, filed on Dec. 28, 1999, now U.S. Pat. No. 6,235,030; which is a continuation of U.S. Ser. No. 09/179,570, filed on Oct. 27, 1998, now U.S. Pat. No. 6,048,342; which is a continuation-in-part of U.S. patent application Ser. No. 08/958,281, filed on Oct. 27, 1997, now U.S. Pat. No. 5,860,977; which is a continuation-in-part of U.S. patent application Ser. No. 08/778,093, filed on Jan. 2, 1997 now U.S. Pat. No. 5,836,948.

[0002] The present application is also a continuation-in-part of U.S. patent application Ser. No. 10/684,847, filed on Oct. 14, 2003; which claims priority to U.S. Provisional Application No. 60/421,921, filed on Oct. 29, 2002; both entitled "Interspinous Process Apparatus and Method with a Selectably Expandable Spacer."

[0003] The present application is also a continuation-in-part of U.S. patent application Ser. No. 11/003,555, filed on Dec. 3, 2004; which claims priority to U.S. Provisional Application No. 60/565,910, filed on Apr. 28, 2004.

[0004] The present application is also a continuation-in-part of U.S. patent application Ser. No. 11/389,002, filed on Mar. 24, 2006; which claims benefit to U.S. Provisional Application No. 60/672,402, filed Apr. 18, 2005; both entitled "Interspinous Process Implant Having Deployable Wings and Method of Implantation."

[0005] All of the above-listed references are incorporated herein by reference.

STATEMENT AS TO RIGHTS TO INVENTIONS MADE UNDER FEDERALLY SPONSORED RESEARCH OR DEVELOPMENT

[0006] Not Applicable

REFERENCE TO A "SEQUENCE LISTING," A TABLE, OR A COMPUTER PROGRAM LISTING APPENDIX SUBMITTED ON A COMPACT DISK

[0007] Not Applicable

BACKGROUND OF THE INVENTION

[0008] The spinal column is a bio-mechanical structure composed primarily of ligaments, muscles, vertebrae and intervertebral disks. The bio-mechanical functions of the spine include: (1) support of the body, which involves the transfer of the weight and the bending movements of the head, trunk, and arms to the pelvis and legs, (2) complex physiological motion between these parts, and (3) protection of the spinal cord and the nerve roots.

[0009] As the present society ages, it is anticipated that there will be an increase in adverse spinal conditions which

are characteristic of older people. By way of example, with aging comes increases in spinal stenosis (including but not limited to central canal and lateral stenosis), the thickening of the bones which make up the spinal column and facet arthropathy. Spinal stenosis results in a reduction foraminal area (i.e., the available space for the passage of nerves and blood vessels) which compresses the cervical nerve roots and causes radicular pain. Humphreys, S. C. et al., Flexion and traction effect on C5-C6 foraminal space, Arch. Phys. Med. Rehabil., vol. 79 at 1105 (September 1998). Another symptom of spinal stenosis is myelopathy, which results in neck pain and muscle weakness. Id. Extension and ipsilateral rotation of the neck further reduces the foraminal area and contributes to pain, nerve root compression and neural injury. Id.; Yoo, J. U. et al., Effect of cervical spine motion on the neuroforaminal dimensions of human cervical spine, Spine, vol. 17 at 1131 (Nov. 10, 1992). In contrast, neck flexion increases the foraminal area. Humphreys, S. C. et al., at 1105.

[0010] Spinal stenosis is characterized by a reduction in the available space for the passage of blood vessels and nerves. Pain associated with such stenosis can be relieved by medication and/or surgery. Of course, it is desirable to eliminate the need for major surgery for all individuals and in particular for the elderly.

[0011] Accordingly, there needs to be developed procedures and implants for alleviating such condition which are minimally invasive, can be tolerated by the elderly and can be performed preferably on an outpatient basis.

[0012] This invention also relates to an apparatus and method for adjustably distracting the spinous process of adjacent vertebrae.

[0013] In addition, there are a variety of other ailments that can cause back pain in patients of all ages. For these ailments it is also desirable to eliminate such pain without major surgery.

[0014] Accordingly, there is a need for a method for alleviating such conditions that is minimally invasive, can be tolerated by patients of all ages (in particular, the elderly), can be performed on an out-patient basis, and allows adjustments both during and after surgery to minimize patient discomfort. There is a further need for an apparatus with which to apply the method.

BRIEF SUMMARY OF THE INVENTION

[0015] The present invention is directed to providing a minimally invasive implant and method for alleviating discomfort associated with the spinal column.

[0016] The present invention provides for apparatus and method for relieving pain by relieving the pressure and restrictions on the aforementioned blood vessels and nerves. Such alleviation of pressure is accomplished in the present invention through the use of an implant and method which distract the spinous process of adjacent vertebra in order to alleviate the problems caused by spinal stenosis and facet arthropathy and the like. While the implant and method particularly address the needs of the elderly, the invention can be used with individuals of all ages and sizes where distraction of the spinous process would be beneficial.

[0017] In one aspect of the invention, an implant is provided for relieving pain comprising a device positioned

between a first spinous process and a second spinous process. The device includes a spinal column extension stop and a spinal column flexion non-inhibitor.

[0018] In another aspect of the invention, the implant is positioned between the first spinous process and the second spinous process and includes a distraction wedge that can distract the first and second spinous processes as the implant is positioned between the spinous processes.

[0019] In yet another aspect of the present invention, the implant includes a device which is adapted to increasing the volume of the spinal canal and/or the neural foramen as the device is positioned between adjacent spinous processes.

[0020] In yet a further aspect of the present invention, a method is presented for relieving pain due to the development of, by way of example only, spinal stenosis and facet arthropathy. The method is comprised of the steps of accessing adjacent first and second spinal processes of the spinal column and distracting the processes a sufficient amount in order to increase the volume of the spinal canal in order to relieve pain. The method further includes implanting a device in order to maintain the amount of distraction required to relieve such pain.

[0021] In yet a further aspect of the invention, the method includes implanting a device in order to achieve the desired distraction and to maintain that distraction.

[0022] In yet a further aspect of the invention, the implant includes a first portion and a second portions. The portions are urged together in order to achieve the desired distraction. In still a further aspect of the invention, the implant includes a distracting unit and a retaining unit. The distracting unit includes a body which can be urged between adjacent spinous processes. The body includes a slot. After the distracting unit is positioned, the retaining unit can fit into the slot of the retaining unit and be secured thereto.

[0023] In yet a further aspect of the invention, the implant includes a first unit with a central body. A sleeve is provided over the central body and is at least partially spaced from the central body in order to allow for deflection toward the central body.

[0024] In a further aspect of the invention, the implant includes a first unit having a central body with a guide and a first wing, with the first wing located at first end of the body. The guide extends from a second end of the body located distally from the first wing. The implant further includes a sleeve provided over said central body. The sleeve is at least partially spaced from the central body in order to allow for deflection of the sleeve toward the central body. The implant further includes a second wing and a device for securing the second wing to the first unit, wherein the sleeve is located between the first and second wings.

[0025] In yet another aspect of the invention, an implant system includes a cylindrical sleeve which is inwardly deflectable. The system further includes an insertion tool which includes an insertion guide, a central body, a stop and a handle. The guide and the stop extend from opposite sides of the central body and the handle extend from the stop. A sleeve fits over the guide and against the stop preparatory to being positioned between the two adjacent vertebrae with the insertion tool.

[0026] In yet a further aspect of the invention, the implant includes central body and first and second wings and a means for selectively positioning one of the first and second wings relative to the other in order to accommodate spinous processes of different sizes.

[0027] In yet still a further aspect of the invention, the implant includes a sleeve which is rotatable relative to the wings of the implant in order to be able to accommodate the anatomical structure of spinous processes.

[0028] In yet still a further aspect of the invention, the sleeve is formed from bar stock comprised of a super-elastic material.

[0029] Other implants and methods within the spirit and scope of the invention can be used to increase the volume of the spinal canal thereby alleviating restrictions on vessels and nerves associated therewith, and pain.

BRIEF DESCRIPTION OF THE DRAWINGS

[0030] FIGS. 1 and 2 depict an embodiment of an implant of the invention which is adjustable in order to select the amount of distraction required. FIG. 1 depicts the implant in a more extended configuration than does FIG. 2.

[0031] FIGS. 3a and 3b depict side and end views of a first forked end of the embodiment of FIG. 1.

[0032] FIGS. 4a and 4b depict side sectioned and end views of an interbody piece of the implant of FIG. 1.

[0033] FIGS. 5a and 5b depict side and end views of a second forked end of the embodiment of FIG. 1.

[0034] FIGS. 6, 7, 8, 9, and 10 depict apparatus and method for another embodiment of the present invention for creating distraction between adjacent spinous processes.

[0035] FIGS. 11, 12, and 13 depict yet a further embodiment of the invention for creating distraction between adjacent spinous processes.

[0036] FIGS. 14 and 15 depict a further apparatus and method of an embodiment of the invention for creating distraction.

[0037] FIGS. 16, 16a, and 17 depict yet another embodiment of the present invention.

[0038] FIGS. 18, 19, and 20 depict yet a further apparatus and method of the present embodiment.

[0039] FIGS. 21 and 22 depict still a further embodiment of the present invention.

[0040] FIGS. 23, 24, and 25 depict another embodiment of the present invention.

[0041] FIGS. 26, 27, and 28 depict another embodiment of the invention.

[0042] FIGS. 29 and 30 depict side elevational views of differently shaped implants of embodiments of the present invention.

[0043] FIGS. 31, 32, and 33 depict various implant positions of an apparatus of the present invention.

[0044] FIGS. 34 and 35 depict yet another apparatus and method of the present invention.

[0045] FIGS. 36, 37, and 38 depict three different embodiments of the present invention.

[0046] FIGS. 39 and 40 depict yet another apparatus and method of an embodiment of the present invention.

[0047] FIGS. 41, 42, and 43 depict yet further embodiments of an apparatus and method of the present invention.

[0048] FIG. 44 is still a further embodiment of an implant of the invention.

[0049] FIG. 45 is yet another depiction of an apparatus and method of the invention.

[0050] FIGS. 46 and 47 depict still a further apparatus and method of an embodiment of the invention.

[0051] FIGS. 48, 49, 50, and 51 depict yet a further apparatus and method of the invention.

[0052] FIGS. 52, 53, 54, 55a, and 55b depict another apparatus and method of the invention.

[0053] FIGS. 56, 57, and 58 depict yet a further apparatus and method of the invention.

[0054] FIGS. 59 and 60 depict still a further embodiment of the invention.

[0055] FIG. 61 depict another embodiment of the invention.

[0056] FIGS. 62 and 63 depict yet another embodiment of the present invention.

[0057] FIGS. 64 and 65 depict still a further embodiment of the present invention.

[0058] FIG. 66 depicts another embodiment of the invention.

[0059] FIGS. 67 and 68 depict yet another embodiment of the present invention.

[0060] FIGS. 69, 70, 71, and 71a depict a further embodiment of the present invention.

[0061] FIGS. 72 and 73 depict still another embodiment of the invention.

[0062] FIGS. 74, 75, 76, 77, and 78 depict still other embodiments of the invention.

[0063] FIGS. 79, 80, 80a, 81, 82, 83, 83a, 84, 85, 86, and 87 depict still a further embodiment of the present invention.

[0064] FIGS. 88, 89, 90, and 91 depict yet another embodiment of the present invention.

[0065] FIGS. 92, 92a, 92b, 93, 93a, 93b, 93c, 93d, 94, 94a, 94b, 95, 95a, and 96, depict still a further embodiment of the present invention wherein a sleeve is provided which is capable of deflecting response to relative motion between the spinous processes.

[0066] FIG. 97 depicts still another embodiment of the present invention.

[0067] FIG. 98 depicts yet a further embodiment of the present invention.

[0068] FIGS. 99 and 100 depict still another embodiment of the present invention including an insertion tool.

[0069] FIGS. 101, 102, 102a, 103, 104, 105, 106, and 107 depict still a further embodiment of the present invention.

[0070] FIGS. 108, 109, and 110 depict still another embodiment of the present invention.

[0071] FIGS. 111, 112, 113, 114, 115, 116, and 117 depict yet another embodiment of the present invention.

[0072] FIG. 118 depicts a graph showing characteristics of a preferred material usable with several of the embodiments of the present invention.

[0073] FIGS. 119a and 119b depict side and plan views of still a further embodiment of the present invention.

[0074] FIGS. 120a and 120b depict side and plan views of the second wing which can be used in conjunction with the embodiment of the invention of FIGS. 119a and 119b.

[0075] FIGS. 121a and 121b depict side and plan views of the first wing and central body of the embodiment of the invention depicted in FIGS. 119a and 119b.

[0076] FIGS. 122a, 122b, and 122c depict top, side and end views of a guide which is a portion of the embodiment of the invention of FIGS. 119a and 119b.

[0077] FIGS. 123a and 123b depict an end view and a cross-sectioned view respectfully of the sleeve of the embodiment of the invention of FIGS. 119a and 119b.

[0078] FIGS. 124a, 124b, and 124c depict a view of the embodiment of the invention of FIGS. 119a and 119b taken through line 124-124 in FIG. 119b shown in with the sleeve in various positions relative to a first wing.

[0079] FIG. 125 depicts an alternative embodiment of the invention as depicted in FIGS. 119a and 119b.

[0080] FIG. 126 depicts yet a further alternative embodiment of the invention depicted in FIGS. 119a and 119b.

[0081] FIG. 127 depicts yet a further embodiment of the invention as depicted in FIGS. 119a and 119b.

[0082] FIG. 128 is still a further embodiment of the invention as depicted in FIG. 93a.

[0083] FIG. 129 depicts still a further embodiment of the invention as depicted in FIGS. 119a and 119b.

[0084] FIG. 130A is a front plan view of one embodiment of an apparatus with a selectably expandable spacer.

[0085] FIG. 130B is a left side view of the apparatus of FIG. 130A.

[0086] FIG. 130C is a front plan view of the apparatus of FIG. 130A including a selectably expandable spacer, a main body and a first wing.

[0087] FIG. 130D is a left side view of the second wing of the apparatus of FIG. 130A.

[0088] FIG. 130E is a front plan view of the second wing of the apparatus of FIG. 130A.

[0089] FIG. 130F is an end view of the selectably expandable spacer of the apparatus of FIG. 130A.

[0090] 131A is a right side view of an embodiment of the selectably adjustable spacer in an unexpanded position.

[0091] FIG. 131B is a right side view of an embodiment of the selectably adjustable spacer in a fully expanded position. FIG. 132A is a right side cross-sectional view of an embodiment of the selectably adjustable spacer in an unexpanded position.

[0092] FIG. 132B is a left side cross-sectional view of an embodiment of the selectably adjustable spacer in a fully expanded position.

[0093] FIG. 133 is a front side view of an embodiment of the selectably adjustable spacer.

[0094] FIG. 134A is a perspective view of an embodiment of the selectably adjustable spacer.

[0095] FIG. 134B is a back view of another embodiment of the spacer similar to that shown in FIG. 134A with a mechanism for allowing the spacer to expand.

[0096] FIG. 135A is a right side view of an alternative embodiment of the selectably expandable spacer with a jack expansion mechanism in an unexpanded position.

[0097] FIG. 135B is a right side view of an alternative embodiment of the selectably expandable spacer with a jack expansion mechanism in a fully expanded position.

[0098] FIG. 136 is a block diagram demonstrating the steps for performing the method.

[0099] FIG. 137 depicts a side view of an embodiment of the implant of the invention, in a first insertion position.

[0100] FIG. 138 is a top-down view of the embodiment of the implant of the invention depicted in FIG. 137 in the first insertion position.

[0101] FIG. 139 is a side view of the embodiment of the implant of the invention depicted in FIG. 137 in a second retention position.

[0102] FIG. 140 illustrates a top-down view of an embodiment of the implant of the invention, the implant positioned under a spinous process of the spine with the tissue expander in the second retention position.

[0103] FIG. 141 depicts a side view of an alternative embodiment of the implant of the invention in a first insertion position.

[0104] FIG. 142 depicts a side view of the alternative embodiment of the implant of the invention illustrated in FIG. 141, in a second retention position.

[0105] FIG. 143 depicts a top view of yet another embodiment of the implant of the invention, in a first insertion position.

[0106] FIG. 144 depicts a side view of the embodiment shown in FIG. 145 of the implant of the invention, in a second retention position.

[0107] FIG. 145 depicts a top view of the embodiment of FIG. 143 in a deployed position between spinous processes.

[0108] FIG. 146 depicts a flow diagram of a method of insertion of an implant of the invention.

[0109] FIG. 147 is a perspective view of an embodiment of an implant in accordance with the present invention having a spacer, a distraction guide, and a wing with an elliptical cross-section.

[0110] FIG. 148 is an end view of the implant of FIG. 147.

[0111] FIG. 149 is a perspective view of another embodiment of an implant in accordance with the present invention having a wing with a teardrop-shaped cross-section.

[0112] FIG. 150 is an end view of a second wing for use with the implant of FIG. 149.

[0113] FIG. 151 is a perspective view of an embodiment of an implant in accordance with the present invention having a rotatable spacer and a wing with an elliptical cross-section.

[0114] FIG. 152 is a perspective view of an embodiment of an implant in accordance with the present invention having a rotatable spacer with two wings that are teardrop-shaped in cross-section.

[0115] FIG. 153 depicts the axis of rotation of the implant of FIG. 152 as seen from an end view.

[0116] FIG. 154 is a perspective view of an embodiment of an implant in accordance with the present invention having a wing that is truncated at a posterior end.

[0117] FIG. 155A is an end view of the implant of FIG. 154.

[0118] FIG. 155B is a truncated second wing for use with the implant of FIG. 155A.

[0119] FIG. 156 is a plan view of an embodiment of an implant in accordance with the present invention wherein a screw is used to secure a second wing to the spacer.

[0120] FIG. 157 is a perspective view of the second wing of FIG. 156.

[0121] FIG. 158 is a perspective view of the implant of FIG. 156.

[0122] FIG. 159A is a front view of a second wing for use with some embodiments of implants of the present invention having a flexible hinge mechanism for securing the second wing to an implant.

[0123] FIG. 159B is a side-sectional view of the second wing of FIG. 159A.

[0124] FIG. 160A is a plan view of an embodiment of an implant for use with the second wing of FIGS. 159A and 159B.

[0125] FIG. 160B is a front view of the second wing of FIGS. 159A and 159B.

[0126] FIG. 161A is a top view of an embodiment of an implant in accordance with the present invention positioned between spinous processes of adjacent cervical vertebrae.

[0127] FIG. 161B is a top view of the implant of FIG. 161A showing wing orientation.

[0128] FIG. 162 is a top view of two such implants of the invention of FIGS. 161A and 161B, positioned in the cervical spine.

[0129] FIG. 163 is a side view of two implants of the invention positioned in the cervical spine, with stops or keeps at the proximal ends of the spinous processes.

[0130] FIG. 164A is a perspective view of an alternative embodiment of an implant in accordance with the present

invention having a first wing and a second wing that can be deployed after arranging the implant between adjacent spinous processes.

[0131] FIG. 164B is a perspective view of the implant of FIG. 164A in a deployed configuration.

[0132] FIG. 165A is a posterior view of the implant of FIGS. 164A and 164B positioned between adjacent spinous processes in an undeployed configuration.

[0133] FIG. 165B is a posterior view of the implant of FIGS. 164A and 164B positioned between adjacent spinous processes in a deployed configuration.

[0134] FIG. 166A is a perspective view of still another embodiment of an implant in accordance with the present invention having a first wing and a second wing that can be deployed after arranging the implant between adjacent spinous processes.

[0135] FIG. 166B is a perspective view of the implant of FIG. 166A in a deployed configuration.

[0136] FIG. 167 is a posterior view of the implant of FIGS. 166A and 166B positioned between adjacent spinous processes in a deployed configuration.

[0137] FIG. 168A is a perspective view of an alternative embodiment of an implant in accordance with the present invention having a first wing and a second wing that can be deployed after arranging the implant between adjacent spinous processes.

[0138] FIG. 168B is a perspective view of the implant of FIG. 168A in a partially deployed configuration.

[0139] FIG. 168C is a perspective view of the implant of FIG. 168A in a fully deployed configuration.

[0140] FIG. 169A is a perspective view of the implant of FIG. 168A including a cannula within which the implant is disposed for insertion into desired location between adjacent spinous processes.

[0141] FIG. 169B is a perspective view of the implant of FIG. 168A in a partially deployed configuration.

[0142] FIG. 169C is a perspective close-up view of the implant of FIG. 168A showing hinged structures connected by cords.

[0143] FIG. 170 illustrates an embodiment of a method for implanting an interspinous implant as shown in FIGS. 147-163 in accordance with the present invention.

[0144] FIG. 171 illustrates an embodiment of a method for implanting an interspinous implant as shown in FIGS. 164A-167 having deployable first and second wings in accordance with the present invention.

[0145] FIG. 172 illustrates an alternative embodiment of a method for implanting an interspinous implant as shown in FIGS. 168A-169B having deployable first and second wings by way of a cannula inserted between adjacent spinous processes in accordance with the present invention.

DETAILED DESCRIPTION OF THE INVENTION

[0146] A first embodiment of the invention is shown in FIGS. 1-5a, 5b. Implant 20 includes first and second forked

ends 22 and 24, each defining a saddle 26, 28 respectively. The forked ends 22, 24 are mated using an interbody piece 30. As can be seen in FIGS. 3a, 3b, the first forked end 22 includes a threaded shaft 32 which projects rearwardly from the saddle 26. The threaded shaft 32 fits into the threaded bore 34 (FIG. 4a) of the interbody piece 30.

[0147] The second forked end 24 (FIGS. 5a, 5b) includes a smooth cylindrical shaft 36 which can fit into the smooth bore 38 of the interbody piece 30.

[0148] FIG. 1 shows the implant 20 in a fully extended position, while FIG. 2 shows the implant in an unextended position. In the unextended position, it can be seen that the threaded shaft 32 of the first forked end 22 fits inside the hollow cylindrical shaft 36 of the second forked end 24.

[0149] For purposes of implantation between adjacent first and second spinous processes of the spinal column, the implant 20 is configured as shown in FIG. 2. The first and second spinous processes are exposed using appropriate surgical techniques and thereafter, the implant 20 is positioned so that saddle 26 engages the first spinous process, and saddle 28 engages the second spinous process. At this point, the interbody piece 30 can be rotated by placing an appropriate tool or pin into the cross holes 40 and upon rotation, the saddle 26 is moved relative to the saddle 28. Such rotation spreads apart or distracts the spinous processes with the resultant and beneficial effect of enlarging the volume of the spinal canal in order to alleviate any restrictions on blood vessels and nerves.

[0150] It is noted that this implant as well as the several other implants described herein act as an extension stop. That means that as the back is bent backwardly and thereby placed in extension the spacing between adjacent spinous processes cannot be reduced to a distance less than the distance between the lowest point of saddle 26 and the lowest point of saddle 28. This implant, however, does not inhibit or in any way limit the flexion of the spinal column, wherein the spinal column is bent forward.

[0151] Preferably, such a device provides for distraction in the range of about 5 mm to about 15 mm. However, devices which can distract up to and above 22 mm may be used depending on the characteristics of the individual patient.

[0152] With all the ligaments (such as the supraspinous ligament) and tissues associated with the spinous processes left intact, the implant 20 can be implanted essentially floating in position in order to gain the benefits of the aforementioned extension stop and flexion non-inhibitor. If desired, one of the saddles 26 can be laterally pinned with pin 29 to one of the spinous processes and the other saddle can be loosely associated with the other spinous processes by using a tether 31 which either pierces or surrounds the other spinous process and then is attached to the saddle in order to position the saddle relative to the spinous process. Alternatively, both saddles can be loosely tethered to the adjacent spinous process in order to allow the saddles to move relative to the spinous processes.

[0153] The shape of the saddles, being concave, gives the advantage of distributing the forces between the saddle and the respective spinous process. This ensures that the bone is not resorbed due to the placement of the implant 20 and that the structural integrity of the bone is maintained.

[0154] The implant 20 in this embodiment can be made of a number of materials, including but not limited to, stainless steel, titanium, ceramics, plastics, elastics, composite materials or any combination of the above. In addition, the modulus of elasticity of the implant can be matched to that of bone, so that the implant 20 is not too rigid. The flexibility of the implant can further be enhanced by providing additional apertures or perforations throughout the implant in addition to the holes 40 which also have the above stated purpose of allowing the interbody piece 30 to be rotated in order to expand the distance between the saddle 26, 28.

[0155] In the present embodiment, it is understood that the spinous processes can be accessed and distracted initially using appropriate instrumentation, and that the implant 20 can be inserted and adjusted in order to maintain and achieve the desired distraction. Alternatively, the spinous process can be accessed and the implant 20 appropriately positioned. Once positioned, the length of the implant can be adjusted in order to distract the spinous processes or extend the distraction of already distracted spinous processes. Thus, the implant can be used to create a distraction or to maintain a distraction which has already been created.

[0156] The placement of implants such as implant 20 relative to the spinous process will be discussed hereinbelow with other embodiments. However, it is to be noted that ideally, the implant 20 would be placed close to the instantaneous axis of rotation of the spinal column so that the forces placed on the implant 20 and the forces that the implant 20 places on the spinal column are minimized.

[0157] Further, it is noted that during the actual process of installing or implanting the implant 20, that the method uses the approach of extending the length of the implant 20 a first amount and then allowing the spine to creep or adjust to this distraction. Thereafter, implant 20 would be lengthened another amount, followed by a period where the spine is allowed to creep or adjust to this new level of distraction. This process could be repeated until the desired amount of distraction has been accomplished. This same method can be used with insertion tools prior to the installation of an implant. The tools can be used to obtain the desired distraction using a series of spinal distraction and spine creep periods before an implant is installed.

[0158] The embodiment of the invention shown in the above FIGS. 6, 7, 8, 9 and 10 includes distraction or spreader tool 50 which has first and second arms 52, 54. Arms 52, 54 are pivotal about pivot point 56 and releasable from pivot point 56 in order to effect the implantation of implant 58. As can be seen in FIG. 6, in cross-section, the arms 52, 54 are somewhat concave in order to cradle and securely hold the first spinous process 60 relative to arm 52 and the second spinous process 62 relative to arm 54. The distraction tool 50 can be inserted through a small incision in the back of the patient in order to address the space between the first spinous process 60 and the second spinous process 62. Once the tool 50 is appropriately positioned, the arms 52, 54 can be spread apart in order to distract the spinous processes. After this has occurred, an implant 58 as shown in FIGS. 8 and 9, or of a design shown in other of the embodiments of this invention, can be urged between the arms 52, 54 and into position between the spinous processes. After this occurs, the arms 52, 54 can be withdrawn from the spinous processes leaving the implant 58 in place. The implant 58 is urged into place

using a tool 64 which can be secured to the implant 58 through a threaded bore 66 in the back of the implant. As can be seen in FIG. 10, the implant 58 includes saddles 68 and 70 which cradle the upper and lower spinous processes 60, 62 in much the same manner as the above first embodiment and also in much the same manner as the individual arms of the tool 50. The saddles as described above tend to distribute the load between the implant and the spinous processes and also assure that the spinous process is stably seated at the lowest point of the respective saddles.

[0159] Another embodiment of the apparatus and method of the invention is shown in FIGS. 11, 12 and 13. In this embodiment, the spreader or distraction tool 80 includes first and second arms 82, 84 which are permanently pivoted at pivot point 86. The arms include L-shaped ends 88, 90. Through a small incision, the L-shaped ends 88, 90 can be inserted between the first and second spinous processes 92, 94. Once positioned, the arms 82, 84 can be spread apart in order to distract the spinous processes. The implant 96 can then be urged between the spinous processes in order to maintain the distraction. It is noted that implant 96 includes wedged surfaces or ramps 98, 100. As the implant 96 is being urged between the spinous processes, the ramps further cause the spinous processes to be distracted. Once the implant 96 is fully implanted, the full distraction is maintained by the planar surfaces 99, 101 located rearwardly of the ramps. It is to be understood that the cross-section of the implant 96 can be similar to that shown for implant 58 or similar to other implants in order to gain the advantages of load distribution and stability.

[0160] In FIGS. 14 and 15, yet another embodiment of the invention is depicted. In this embodiment, the implant 110 includes first and second conically shaped members 112, 114. Member 112 includes a male snap connector 116 and member 114 includes a female snap connector 118. With male snap connector 116 urged into female snap connector 118, the first member 112 is locked to the second member 114. In this embodiment, a distraction or spreader tool 80 could be used. Once the spinous process has been spread apart, an implantation tool 120 can be used to position and snap together the implant 110. The first member 112 of implant 110 is mounted on one arm and second member 114 is mounted on the other arm of tool 120. The member 112, 114 are placed on opposite sides of the space between adjacent spinous processes. The members 112, 114 are urged together so that the implant 110 is locked in place between the spinous processes as shown in FIG. 15. It is to be noted that the implant 110 can also be made more self-distracting by causing the cylindrical surface 122 to be more conical, much as surface 124 is conical, in order to hold implant 110 in place relative to the spinous processes and also to create additional distraction.

[0161] An alternative embodiment of the implant can be seen in FIGS. 16 and 17. This implant 130 includes first and second members 132, 134. In this particular embodiment, the implants are held together using a screw (not shown) which is inserted through countersunk bore 136 and engages a threaded bore 138 of the second member 134. Surfaces 139 are flattened (FIG. 17) in order to carry and spread the load applied thereto by the spinous processes.

[0162] The embodiment of implant 130 is not circular in overall outside appearance, as is the embodiment 110 of

FIGS. 14 and 15. In particular, with respect to the embodiment of implant 130 of FIGS. 16 and 17, this embodiment is truncated so that the lateral side 140, 142 are flattened with the upper and lower sides 144, 146 being elongated in order to capture and create a saddle for the upper and lower spinous processes. The upper and lower sides, 144, 146 are rounded to provide a more anatomical implant which is compatible with the spinous processes.

[0163] If it is desired, and in order to assure that the first member 132 and the second member 134 are aligned, key 148 and keyway 150 are designed to mate in a particular manner. Key 148 includes at least one flattened surface, such as flattened surface 152, which mates to an appropriately flattened surface 154 of the keyway 150. In this manner, the first member is appropriately mated to the second member in order to form appropriate upper and lower saddles holding the implant 130 relative to the upper and lower spinous processes.

[0164] FIG. 16a depicts second member 134 in combination with a rounded nose lead-in plug 135. Lead-in plug 135 includes a bore 137 which can fit snugly over key 148. In this configuration, the lead-in plug 135 can be used to assist in the placement of the second member 134 between spinous processes. Once the second member 134 is appropriately positioned, the lead-in plug 135 can be removed. It is to be understood that the lead-in plug 135 can have other shapes such as pyramids and cones to assist in urging apart the spinous processes and soft tissues in order to position the second member 134.

[0165] The implant 330 as shown in FIG. 18 is comprised of first and second mating wedges 332 and 334. In order to implant these wedges 332, 334, the spinous processes are accessed from both sides and then a tool is used to push the wedges towards each other. As the wedges are urged towards each other, the wedges move relative to each other so that the combined dimension of the implant 330 located between the upper and lower spinous processes 336, 338 (FIG. 20), increases, thereby distracting the spinous processes. It is noted that the wedges 332, 334 include saddle 340, 342, which receiving the spinous processes 336, 338. These saddles have the advantages as described hereinabove.

[0166] The first or second wedges 332, 334 have a mating arrangement which includes a channel 344 and a projection of 346 which can be urged into the channel in order to lock the wedges 332, 334 together. The channel 344 is undercut in order to keep the projection from separating therefrom. Further, as in other devices described herein, a detent can be located in one of the channel and the projection, with a complimentary recess in the other of the channel and the projection. Once these two snap together, the wedges are prevented from sliding relative to the other in the channel 344.

[0167] While the above embodiment was described with respect to wedges, the wedges could also have been designed substantially as cones with all the same features and advantages.

[0168] The implant 370 is comprised of first and second distraction cone 372, 374. These cones are made of a flexible material. The cones are positioned on either side of the spinous processes 376, 378 as shown in FIG. 21. Using appropriate tool as shown hereinabove, the distraction cones

372, 374 are urged together. As they are urged together, the cones distract the spinous processes as shown in FIG. 22. Once this has occurred, an appropriate screw or other type of fastening mechanism 380 can be used to maintain the position of the distraction cones 372, 374. The advantage of this arrangement is that the implant 370 is self-distracting and also that the implant, being flexible, molds about the spinous processes as shown in FIG. 22.

[0169] In FIGS. 23 and 24, another embodiment of the implant 170 is depicted. This implant is guided in place using an L-shaped guide 172 which can have a concave cross-section such as the cross-section 52 of retraction tool 50 in FIG. 6 in order to cradle and guide the implant 170 in position. Preferably a small incision would be made into the back of the patient and the L-shaped guide tool 172 inserted between the adjacent spinous processes. The implant 170 would be mounted on the end of insertion tool 174 and urged into position between the spinous processes. The act of urging the implant into position could cause the spinous processes to be further distracted if that is required. Prior to the insertion of the L-shaped guide tool 172, a distraction tool such as shown in FIG. 13 could be used to initially distract the spinous processes.

[0170] Implant 170 can be made of a deformable material so that it can be urged into place and so that it can somewhat conform to the shape of the upper and lower spinous processes. This deformable material would be preferably an elastic material. The advantage of such a material would be that the load forces between the implant and the spinous processes would be distributed over a much broader surface area. Further, the implant would mold itself to an irregular spinous process shape in order to locate the implant relative to spinous processes.

[0171] With respect to FIG. 25, this implant 176 can be inserted over a guide wire, guide tool or stylet 178. Initially, the guide wire 178 is positioned through a small incision to the back of the patient to a position between the adjacent spinous processes. After this has occurred, the implant is threaded over the guide wire 178 and urged into position between the spinous processes. This urging can further distract the spinous processes if further distraction is required. Once the implant is in place, the guide tool 178 is removed and the incision closed. The insertion tools of FIGS. 23 and 24 can also be used if desired.

[0172] As can be seen in FIGS. 29 and 30, the implants 210, 212, can have different shapes when viewed from the side. These implants are similar to the above-referenced implants 58 (FIG. 8) and 204 (FIG. 28). These implants have cross-sections similar to that shown in FIG. 10 which includes saddles in order to receive and hold the adjacent spinous processes.

[0173] As can be seen in FIGS. 31, 32 and 33, these implants can be placed in different positions with respect to the spinous process 214. Preferably as shown in FIG. 33, the implant 210 is placed closest to the lamina 216. Being so positioned, the implant 210 is close to the instantaneous axis of rotation 218 of the spinal column, and the implant would experience least forces caused by movement of the spine. Thus, theoretically, this is the optimal location for the implant.

[0174] As can be seen in FIGS. 31 and 32, the implant can be placed midway along the spinous process (FIG. 32) and

towards the posterior aspect of the spinous process (FIG. 31). As positioned shown in FIG. 31, the greatest force would be placed on the implant 210 due to a combination of compression and extension of the spinal column.

[0175] Another embodiment of the invention is shown in FIGS. 34 and 35. In these figures, implant 220 is comprised of a plurality of individual leaves 222 which are substantially V-shaped. The leaves include interlocking indentations or detents 224. That is, each leaf includes an indentation with a corresponding protrusion such that a protrusion of one leaf mates with an indentation of an adjacent leaf. Also associated with this embodiment is an insertion tool 226 which has a blunt end 228 which conforms to the shape of an individual leaf 222. For insertion of this implant into the space between the spinous processes as shown in FIG. 29, the insertion tool 226 first insert a single leaf 220. After that has occurred, the insertion tool then inserts a second leaf with the protrusion 224 of the second leaf snapping into corresponding indentation made by the protrusion 224 of the first leaf. This process would reoccur with third and subsequent leaves until the appropriate spacing between the spinous processes was built up. As can be seen in FIG. 29, the lateral edges 229 of the individual leaves 222 are slightly curved upwardly in order to form a saddle for receiving the upper and lower spinous processes.

[0176] The embodiments of FIGS. 36, 37 and 38 which include implants 230, 232, and 234 respectively, are designed in such a manner so the implant locks itself into position once it is properly positioned between the spinous processes. Implant 220 is essentially a series of truncated cones and includes a plurality of ever expanding steps 236. These steps are formed by the conical bodies starting with the nose body 238 followed there behind by conical body 240. Essentially, the implant 234 looks like a fir tree placed on its side.

[0177] The implant 230 is inserted laterally throughout the opening between upper and lower spinous processes. The first body 238 causes the initial distraction. Each successive conical body distracts the spinous processes a further incremental amount. When the desired distraction has been reached, the spinous processes are locked into position by steps 236. At this point, if desired, the initial nose body 238 of the implant and other bodies 240 can be broken, snapped or sawed off if desired in order to minimize the size of the implant 230. In order for a portion of the implant 230 to be broken or snapped off, the intersection between bodies such as body 238 and 240, which is intersection line 242, would be somewhat weaken with the appropriate removal of material. It is noted that only the intersection lines of the initial conical bodies need to be so weakened. Thus, intersection line 244 between the bodies which remain between the spinous processes would not need to be weaker, as there would be no intention that the implant would be broken off at this point.

[0178] FIG. 37 shows implant 232 positioned between upper and lower spinous processes. This implant is wedge-shaped or triangular shaped in cross-sectioned and includes bore pluralities 245 and 246. Through these bores can be placed locking pins 248 and 250. The triangular or wedged-shaped implant can be urged laterally between and thus distract the upper and lower spinous processes. Once the appropriate distraction is reached, pins 248, 250 can be

inserted through the appropriate bores of the bore pluralities 245 and 246 in order to lock the spinous processes in a V-shaped valley formed by pins 248, 250 on the one hand and the ramped surface 233, 235 on the other hand.

[0179] Turning to FIG. 38, the implant 234 has a triangular-shaped or wedge-shaped body similar to that shown in FIG. 32. In this embodiment, tab 252, 254 are pivotally mounted to the triangular shaped body 234. Once the implant 234 is appropriately positioned in order to distract the spinous processes to the desired amount, the tabs 252, 254 rotate into position in order to hold the implant 234 in the appropriate position.

[0180] In the embodiment of FIGS. 39 and 40, cannula 258 is inserted through a small incision to a position between upper and lower spinous processes. Once the cannula is properly inserted, an implant 260 is pushed through the cannula 258 using an insertion tool 262. The implant 260 includes a plurality of ribs or indentation 264 that assist in positioning the implant 260 relative to the upper and lower spinal processes. Once the implant 260 is in position, the cannula 258 is withdrawn so that the implant 260 comes in contact with and wedges between the spinous processes. The cannula 258 is somewhat conical in shape with the nose end 266 being somewhat smaller than the distal end 268 in order to effect the insertion of the cannula into the space between the spinous processes.

[0181] Further, a plurality of cannula can be used instead of one, with each cannula being slightly bigger than one before. In the method of the invention, the first smaller cannula would be inserted followed by successively larger cannula being placed over the previous smaller cannula. The smaller cannula would then be withdrawn from the center of the larger cannula. Once the largest cannula is in place, and the opening of the skin accordingly expanded, the implant, which is accommodated by only the larger cannula, is inserted through the larger cannula and into position.

[0182] The precurved implant 270 in FIGS. 41 and 42, and precurved implant 272 in FIG. 43 have common introduction techniques which includes a guide wire, guide tool, or stylet 274. For both embodiments, the guide wire 274 is appropriately positioned through the skin of the patient and into the space between the spinous processes. After this is accomplished, the implant is directed over the guide wire and into position between the spinous processes. The precurved nature of the implant assist in (1) positioning the implant through a first small incision in the patient's skin on one side of the space between two spinous processes and (2) guiding the implant toward a second small incision in the patient's skin on the other side of the space between the two spinous processes. With respect to the implant 270, the implant includes a conical introduction nose 276 and a distal portion 278. As the nose 276 is inserted between the spinous processes, this causes distraction of the spinous processes. Break lines 280, 282 are established at opposite sides of the implant 270. Once the implant is properly positioned over the guide wire between the spinous processes, the nose portion 276 and the distal portion 278 can be broken off along the break lines, through the above two incisions, in order to leave the implant 270 in position.

[0183] Although only two break lines 280, 282 are depicted, multiple break lines can be provided on implant 270 so that the implant can continue to be fed over the guide

wire 278 until the appropriate width of the implant 270 creates the desired amount of distraction. As described hereinabove, the break lines can be created by perforating or otherwise weakening the implant 270 so that the appropriate portions can be snapped or sawed off.

[0184] With respect to the precurved implant 272, this implant is similar in design to the implant 230 shown in FIG. 36. This implant 272 in FIG. 47, however, is precurved and inserted over a guide wire 274 to a position between the spinous processes. As with implant 230 in FIG. 43, once the appropriate level of this distraction has been reached and if desired, sections of the implant 272 can be broken, snapped or sawed off as described hereinabove in order to leave a portion of the implant wedged between the upper and lower spinous processes.

[0185] A further embodiment of the invention is shown in FIG. 44. This embodiment includes a combination insertion tool and implant 290. The insertion tool and implant 290 is in the shape of a ring which is hinged at point 292. The ring is formed by a first elongated and conically shaped member 294 and a second elongated and conically shaped member 296. Members 294 and 296 terminate in points and through the use of hinge 292 are aligned and meet. Through similar incisions on both sides of the spinous processes, first member and second member are inserted through the skins of the patient and are mated together between the spinous processes. After this has occurred, the implant 290 is rotated, for example clockwise, so that increasingly widening portions of the first member 292 are used to distract the first and second spinous processes. When the appropriate level of distraction has occurred, the remainder of the ring before and after the section which is located between the spinous processes can be broken off as taught hereinabove in order to maintain the desired distraction. Alternatively, with a small enough ring, the entire ring can be left in place with the spinous processes distracted.

[0186] In FIG. 45, the implant 300 is comprised of a plurality of rods or stylets 302 which are inserted between the upper and lower spinous processes. The rods are designed much as described hereinabove so that they may be broken, snapped or cut off. Once these are inserted and the appropriate distraction has been reached, the stylets are broken off and a segment of each stylet remains in order to maintain distraction of the spinous process.

[0187] Implant 310 of FIGS. 46 and 47 is comprised of a shape memory material which coils upon being released. The material is straightened out in a delivery tool 312. The delivery tool is in position between upper and lower spinous processes 314, 316. The material is then pushed through the delivery tool. As it is released from the delivery end 318 of the delivery tool, the material coils, distracting the spinous processes to the desired amount. Once this distraction has been achieved, the material is cut and the delivery tool removed.

[0188] As can be seen in FIG. 48, the implant 320 is delivered between upper and lower spinous processes 322 and 324, by delivery tool 326. Once the implant 320 is in place between the spinous processes, the delivery tool is given a 90.degree. twist so that the implant goes from the orientation as shown in FIG. 49, with longest dimension substantially perpendicular to the spinous processes, to the orientation shown in FIG. 50 where the longest dimension is

in line with and parallel to the spinous processes. This rotation causes the desired distraction between the spinous processes. Implant 320 includes opposed recesses 321 and 323 located at the ends thereof. Rotation of the implant 320 causes the spinous processes to become lodged in these recesses.

[0189] Alternatively, the insertion tool 326 can be used to insert multiple implants 320, 321 into the space between the spinous processes 322, 324 (FIG. 51). Multiple implants 320, 321 can be inserted until the appropriate amount of distraction is built up. It is to be understood in this situation that one implant would lock to another implant by use of, for example, a channel arrangement wherein a projection from one of the implants would be received into and locked into a channel of the other implant. Such a channel arrangement is depicted with respect to the other embodiment.

[0190] The embodiment of FIGS. 52 through 55b is comprised of a fluid-filled dynamic distraction implant 350. This implant includes a membrane 352 which is placed over pre-bent insertion rod 354 and then inserted through an incision on one side of the spinous process 356. The bent insertion rod, with the implant 350 thereover, is guided between appropriate spinous processes. After this occurs, the insertion rod 354 is removed leaving the flexible implant in place. The implant 350 is then connected to a source of fluid (gas, liquid, gel and the like) and the fluid is forced into the implant causing it to expand as shown in FIG. 54, distracting the spinal processes to the desired amount. Once the desired amount of distraction has occurred, the implant 350 is closed off as is shown in FIG. 55a. The implant 350 being flexible, can mold to the spinous processes which may be of irregular shape, thus assuring positioning. Further, implant 350 acts as a shock absorber, damping forces and stresses between the implant and the spinous processes.

[0191] A variety of materials can be used to make the implant and the fluid which is forced into the implant. By way of example only, viscoelastic substances such as methylcellulose, or hyaluronic acid can be used to fill the implant. Further, materials which are initially a fluid, but later solidify, can be inserted in order to cause the necessary distraction. As the materials solidify, they mold into a custom shape about the spinous processes and accordingly are held in position at least with respect to one of two adjacent spinous processes. Thus, it can be appreciated that using this embodiment and appropriate insertion tools the implant can be formed about one spinous process in such a manner that the implant stays positioned with respect to that spinous process (FIG. 55b). With such an embodiment, a single implant can be used as an extension stop for spinous process located on either side, without restricting flexion of the spinal column.

[0192] It is to be understood that many of the other implants disclosed herein can be modified so that they receive a fluid in order to establish and maintain a desired distraction such in the manner as implant 350 receives a fluid.

[0193] The implant 360 as shown in FIG. 56 is comprised of a shape memory material such as a plastic or a metal. A curved introductory tool 362 is positioned between the appropriate spinous processes as described hereinabove. Once this has occurred, bore 364 of the implant is received over the tool. This act can cause the implant to straighten

out. The implant is then urged into position and thereby distracts the spinous processes. When this has occurred, the insertion tool **362** is removed, allowing the implant to assume its pre-straightened configuration and is thereby secured about one of the spinous processes. Such an arrangement allows for an implant that is an extension stop and does not inhibit flexion of the spinous column. Alternatively, the implant can be temperature sensitive. That is to say that the implant would be more straightened initially, but become more curved when it was warmed by the temperature of the patient's body.

[0194] In this embodiment, the implant **380** is comprised of a plurality of interlocking leaves **382**. Initially, a first leaf is positioned between opposed spinous processes **384**, **386**. Then subsequently, leafs **382** are interposed between the spinous processes until the desired distraction has been built up. The leaves are somewhat spring-like in order to absorb the shock and can somewhat conform to the spinous processes.

[0195] The implant **390** of FIG. **61** includes the placement of shields **392**, **394** over adjacent spinous processes **396**, **398**. The shields are used to prevent damage to the spinous processes. These shields include apertures which receives a self-tapping screw **400**, **402**. In practice, the shields are affixed to the spinous processes and the spinous processes are distracted in the appropriate amount. Once this has occurred, a rod **404** is used to hold the distracted position by being screwed into each of the spinous processes through the aperture in the shields using the screws as depicted in FIG. **61**.

[0196] Implant **410** of FIGS. **62**, **63** is comprised of first and second members **412**, **414** which can be mated together using an appropriate screw and threaded bore arrangement to form the implant **410**. Main member **412** and mating member **414** form implant **410**. Accordingly, the implant **410** would have a plurality of members **414** for use with a standardized first member **412**. FIGS. **62** and **64** show different types of mating members **414**. In FIG. **62**, the mating member **414** includes projections **416** and **418** which act like shims. These projections are used to project into the space of saddles **420**, **422** of the first member **412**. These projections **416**, **418** can be of varying lengths in order to accommodate different sizes of spinous processes. A groove **424** is placed between the projections **416**, **418** and mates with an extension **426** of the first member **412**.

[0197] As shown in FIG. **63**, the projections of the embodiment shown in FIG. **62** are removed and recesses **428**, **430** are substituted therefor. These recesses expand the area of the saddles **420**, **422** in order to accommodate larger spinous processes.

[0198] The embodiments of FIGS. **64**, **65** and **66** are similar in design and concept to the embodiment of FIGS. **62** and **63**. In FIG. **64**, the implant **500** includes the first and second members **502**, **504**. These members can be secured together with appropriate screws or other fastening means as taught in other embodiments. Implant **500** includes first and second saddles **506**, **508** which are formed between the ends of first and second members **502**, **504**. These saddles **506**, **508** are used to receive and cradle the adjacent spinous processes. As can be seen in FIG. **64**, each saddle **506**, **508** is defined by a single projection or leg **510**, **512**, which extends from the appropriate first and second members **502**,

504. Unlike the embodiment found in FIGS. **62** and **63**, each of the saddles is defined by only a single leg as the ligaments and other tissues associated with the spinous processes can be used to ensure that the implant is held in an appropriate position. With the configuration of FIG. **64**, it is easier to position the implant relative to the spinous processes as each saddle is defined by only a single leg and thus the first and second members can be more easily worked into position between the various tissues.

[0199] In the embodiment of FIG. **65**, the implant **520** is comprised of a single piece having saddles **522** and **524**. The saddles are defined by a single leg **526**, **528** respectively. In order for this implant **520** to be positioned between the spinous processes, an incision is made between lateral sides of adjacent spinous processes. The single leg **526** is directed through the incision to a position adjacent to an opposite lateral side of the spinous process with the spinous process cradled in the saddle **522**. The spinous processes are then urged apart until saddle **524** can be pivoted into position into engagement with the other spinous process in order to maintain the distraction between the two adjacent spinous processes.

[0200] The embodiment of FIG. **66** is similar to that of FIG. **65** with an implant **530** and first and second saddles **532** and **534**. Associated with each saddle is a tether **536**, **538** respectively. The tethers are made of flexible materials known in the trade and industry and are positioned through bores in the implant **530**. Once appropriately positioned, the tethers can be tied off. It is to be understood that the tethers are not meant to be used to immobilize one spinous process relative to the other, but are used to guide motion of the spinous processes relative to each other so that the implant **530** can be used as an extension stop and a flexion non-inhibitor. In other words, the saddles **532**, **534** are used to stop spinal column backward bending and extension. However, the tethers do not inhibit forward bending and spinal column flexion.

[0201] The implant **550** is Z-shaped and includes a central body **552** and first and second arms **554**, **556**, extending in opposite directions therefrom. The central body **552** of the implant **550** includes first and second saddles **558** and **560**. The first and second saddles **558** and **560** would receive upper and lower spinous processes **562**, **568**. The arms **554**, **556** are accordingly located adjacent the distal end **566** (FIG. **68**) of the central body **552**. The first and second arms **554**, **556**, act to inhibit forward movement, migration or slippage of the implant **550** toward the spinal canal and keep the implant in place relative to the first and second spinal processes. This prevents the implant from pressing down on the ligamentum flavum and the dura. In a preferred embodiment, the central body would have a height of about 10 mm with each of the arms **554**, **556** have a height of also about 10 mm. Depending on the patient, the height of the body could vary from about less than 10 mm to about greater than 24 mm. As can be seen in FIGS. **67** and **68**, the first and second arms **554**, **556** are additionally contoured in order to accept the upper and lower spinous processes **556**, **558**. In particular, the arms **554**, **556** as can be seen with respect to arm **554** have a slightly outwardly bowed portion **568** (FIG. **68**) with a distal end **570** which is slightly inwardly bowed. This configuration allows the arm to fit about the spinous process with the distal end **570** somewhat urged against the spinous process in order to guide the motion of the spinous

process relative to the implant. These arms **554**, **556** could if desired be made more flexible than the central body **552** by making arms **554**, **556** thin and/or with perforations, and/or other material different than that of the central body **550**. As with the last embodiment, this embodiment can be urged into position between adjacent spinous processes by directing an arm into a lateral incision so that the central body **552** can be finally positioned between spinous processes.

[0202] FIGS. **69**, **70** and **71** are perspective front, end, and side views of implant **580** of the invention. This implant includes a central body **582** which has first and second saddles **584**, **586** for receiving adjacent spinous processes. Additionally, the implant **580** includes first and second arms **588** and **590**. The arms, as with the past embodiment, prevent forward migration or slippage of the implant toward the spinal canal. First arm **588** projects outwardly from the first saddle **584** and second arm **590** projects outwardly from the second saddle **586**. In a preferred embodiment, the first arm **588** is located adjacent to the distal end **600** of the central body **582** and proceeds only partly along the length of the central body **582**. The first arm **588** is substantially perpendicular to the central body as shown in FIG. **70**. Further, the first arm **588**, as well as the second arm **590**, is anatomically rounded.

[0203] The second arm **590**, projecting from second saddle **586**, is located somewhat rearward of the distal end **600**, and extends partially along the length of the central body **582**. The second arm **590** projects at a compound angle from the central body **582**. As can be seen in FIGS. **70** and **71**, the second arm **590** is shown to be at about an angle of 45.degree. from the saddle **586** (FIG. **70**). Additionally, the second arm **590** is at an angle of about 45.degree. relative to the length of the central body **580** as shown in FIG. **71**. It is to be understood that other compound angles are within the spirit and scope of the invention as claimed.

[0204] In a preferred embodiment, the first and second arms **588**, **590** have a length which is about the same as the width of the central body **582**. Preferably, the length of each arm is about 10 mm and the width of the central body is about 10 mm. However, the bodies with the widths of 24 mm and greater are within the spirit and scope of the invention, along with first and second arms ranging from about 10 mm to greater than about 24 mm. Further, it is contemplated that the embodiment could include a central body having a width of about or greater than 24 mm with arms being at about 10 mm.

[0205] It is to be understood that the embodiment of FIGS. **69**, **70** and **71** as well as the embodiment of FIGS. **67** and **68** are designed to preferably be positioned between the L4-L5 and the L5-S1 vertebral pairs. The embodiment of FIGS. **69**, **70**, **71** is particularly designed for the L5-S1 position with the arms being designed to conform to the sloping surfaces found therebetween. The first and second arms are thus contoured so that they lie flat against the lamina of the vertebra which has a slight angle.

[0206] The embodiment of FIGS. **69**, **70**, and **71** as with the embodiment of FIGS. **67** and **68** is Z-shaped in configuration so that it may be inserted from one lateral side to a position between adjacent spinous processes. A first arm, followed by the central body, is guided through the space between the spinous processes. Such an arrangement only

requires that a incision on one side of the spinous process be made in order to successfully implant the device between the two spinous processes.

[0207] The implant **610** of FIG. **71a** is similar to that immediately above with the first arm **612** located on the same side of the implant as the second arm **614**. The first and second saddle **616**, **618** are slightly modified in that distal portion **620**, **622** are somewhat flattened from the normal saddle shape in order to allow the implant to be positioned between the spinous processes from one side. Once in position, the ligaments and tissues associated with the spinous processes would hold the implant into position. Tethers also could be used if desired.

[0208] Implant **630** is also designed so that it can be inserted from one side of adjacent spinous processes. This insert **630** includes a central body **632** with the first and second arms **634**, **636** extending on either side thereof. As can be seen in FIG. **72**, a plunger **638** is positioned to extend from an end of the central body **632**. As shown in FIG. **72**, the plunger **638** is fully extended and as shown in FIG. **73**, the plunger **638** is received within the central body **632** of the implant **630**. With the plunger received into the implant **632**, the third and fourth arms or hooks **640**, **642** can extend outwardly from the central body **632**. The third and fourth arms or hooks **640**, **642** can be comprised of a variety of materials, such as for example, shape memory metal materials or materials which have a springy quality.

[0209] For purposes of positioning the implant **630** between adjacent spinous processes, the plunger **638** is pulled outwardly as shown in FIG. **72**. The central body **632** is then positioned between adjacent spinous processes and the plunger **638** is allowed to move to the position of FIG. **73** so that the third and fourth arms **640**, **642** can project outwardly from the central body **632** in order to hold the implant **630** in position between the spinous processes.

[0210] Plunger **638** can be spring biased to the position as shown in FIG. **73** or can include detents or other mechanisms which lock it into that position. Further, the third and fourth arms themselves, as deployed, can keep the plunger in the position as shown in FIG. **73**.

[0211] Other embodiments of the invention are shown in FIGS. **74** through **78**. FIGS. **74**, **75** and **76** disclose implant **700**. Implant **700** is particularly suited for implantation between the L4-L5 and L5-S1 vertebra. As can be seen in FIG. **74**, the implant **700** includes a central body **702** which has a bore **704** provided therein. Bore **704** is used in order to adjust the modulus of elasticity of the implant so that it is preferably approximately two times the anatomical load placed on the vertebra in extension. In other words, the implant **700** is approximately two times stiffer than the normal load placed on the implant. Such an arrangement is made in order to ensure that the implant is somewhat flexible in order to reduce potential resorption of the bone adjacent to the implant. Other modulus values can be used and be within the spirit of the invention.

[0212] Implant **700** includes first and second saddle **706**, **708** which are used to receive and spread the load from the upper and lower spinous processes. The saddle **706** is defined by first and second arms **710** and **712**. The second saddle **708** is defined by third and fourth arms **714** and **716**. As can be seen in FIG. **74**, the first arm **710**, in a preferred

embodiment, is approximately two times the length of the body **702** with the second arm being approximately less than a quarter length of the body. Third arm **714** is approximately one times the length of the body **702** with the fourth arm **716** being, in this preferred embodiment, approximately one and a half times the length of the body **702**. The arms are designed in such a way that the implant (1) can be easily and conveniently inserted between the adjacent spinous processes, (2) will not migrate forwardly toward the spinal canal, and (3) will hold its position through flexion and extension as well as lateral bending of the spinal column.

[0213] First arm **710** is in addition designed to accommodate the shape of the vertebra. As can be seen in FIG. **74**, the first arm **710** becomes narrower as it extends away from the body **702**. The first arm **710** includes a sloping portion **718** followed by a small recess **720** ending in a rounded portion **722** adjacent to the end **724**. This design is provided to accommodate the anatomical form of for example the L4 vertebra. It is to be understood that these vertebra have a number of surfaces at roughly 30.degree. angles and that the sloping surfaces of this embodiment and the embodiments shown in FIGS. **77** and **78** are designed to accommodate these surfaces. These embodiments can be further modified in order to accommodate other angles and shapes.

[0214] The second arm **712** is small so that it is easy to insert between the spinous processes, yet still define the saddle **706**. The fourth arm **716** is larger than the third arm **714**, both of which are smaller than the first arm **710**. The third and fourth arms are designed so that they define the saddle **706**, guide the spinous processes relative to the implant **700** during movement of the spinal column, and yet are of a size which makes the implant easy to position between the spinous processes.

[0215] The procedure, by way of example only, for implanting the implant **700** can be to make an incision laterally between two spinous processes and then initially insert first arm **710** between the spinous processes. The implant and/or appropriate tools would be used to distract the spinous processes allowing the third leg **714** and the central body **702** to fit through the space between the spinous processes. The third leg **714** would then come to rest adjacent the lower spinous processes on the opposite side with the spinous processes resting in the first and second saddle **706**, **708**. The longer fourth leg **716** would then assist in the positioning of the implant **700**.

[0216] FIG. **77** includes an implant **740** which is similar to implant **700** and thus have similar numbering. The saddle **706**, **708** of implant **740** have been cantered or sloped in order to accommodate the bone structure between, by way of example, the L4-L5 and the L5-S1 vertebra. As indicated above, the vertebra in this area have a number of sloping surfaces in the range of about 30.degree. Accordingly, saddle **706** is sloped at less than 30.degree. and preferably about 20.degree. while saddle **708** is sloped at about 30.degree. and preferably more than 30.degree.

[0217] The implant **760** as shown in FIG. **78** is similar to implant **700** in FIG. **74** and is similarly numbered. Implant **760** includes third and fourth legs **714**, **716** which have sloping portions **762**, **764** which slope toward ends **766**, **768** of third and fourth arm **714**, **716** respectively. The sloping portions accommodate the form of the lower vertebra against which they are positioned. In the preferred embodi-

ment, the sloping portions are of about 30.degree. However, it is to be understood that sloping portions which are substantially greater and substantially less than 30.degree. can be included and be within the spirit and scope of the invention.

[0218] Another embodiment of the invention is shown in FIGS. **79-87** and includes implant **800** (FIG. **86**). Implant **800** includes a distracting unit **802** which is shown in left side, plan, and right side views of FIGS. **79**, **80** and **81**. A perspective view of the distraction unit is shown in FIG. **84**. The distracting unit as can be seen in FIG. **80** includes a distracting body **804**, with longitudinal axis **805**, which body **804** has a groove **806** and a rounded or bulbous end **808** which assist in the placement of the distracting body between adjacent spinous process so that an appropriate amount of distraction can be accomplished. Extending from the distracting body **804** is a first wing **810** which in FIG. **80** is substantially perpendicular to the distracting body **804**. Such wings which are not perpendicular to the body are within the spirit and scope of the invention. First wing **810** includes an upper portion **812** and a lower portion **814**. The upper portion **810** (FIG. **79**) includes a rounded end **816** and a small recess **818**. The rounded end **816** and the small recess **818** in the preferred embodiment are designed to accommodate the anatomical form or contour of the L4 (for a L4-L5 placement) or L5 (for a L5-S1 placement) superior lamina of the vertebra. It is to be understood that the same shape or variations of this shape can be used to accommodate other lamina of any vertebra. The lower portion **814** is also rounded in order to accommodate in the preferred embodiment in order to accommodate the vertebrae. The distracting unit further includes a threaded bore **820** which in this embodiment accepts a set screw **822** (FIG. **86**) in order to hold a second wing **824** (FIGS. **82**, **83**) in position as will be discussed hereinbelow.

[0219] The threaded bore **820** in this embodiment slopes at approximately 45.degree. angle and intersects the slot **806**. With the second wing **824** in position, the set screw **822** when it is positioned in the threaded bore **820** can engage and hold the second wing **824** in position in the slot **806**.

[0220] Turning to FIGS. **82**, **83** and **85**, left side, plan and perspective views of the second wing **824** are depicted. The second wing **824** is similar in design to the first wing. The second wing includes an upper portion **826** and a lower portion **828**. The upper portion includes a rounded end **830** and a small recess **832**. In addition, the second wing **824** includes a slot **834** which mates with the slot **806** of the distracting unit **802**. The second wing **824** is the retaining unit of the present embodiment.

[0221] As can be seen in FIGS. **83** and **86**, the second wing or retaining unit **824** includes the upper portion **826** having a first width "a" and the lower portion **828** having a second width "b". In the preferred embodiment, the second width "b" is larger than first width "a" due to the anatomical form or contour of the L4-L5 or L5-S1 laminae. As can be seen in FIG. **83a** in second wing or retaining unit **824**, the widths "a" and "b" would be increased in order to, as described hereinbelow, accommodate spinous processes and other anatomical forms or contours which are of different dimensions. Further, as appropriate, width "a" can be larger than width "b". Thus, as will be described more fully hereinbelow, the implant can include a universally-shaped distracting

unit **802** with a plurality of retaining units **824**, with each of the retaining units having different widths “a” and “b”. During surgery, the appropriately sized retaining unit **824**, width with the appropriate dimensions “a” and “b” can be selected to match to the anatomical form of the patient.

[0222] FIG. **86** depicts an assembled implant **800** positioned adjacent to upper and lower laminae **836**, **838** (which are shown in dotted lines) of the upper and lower vertebrae. The vertebrae **836**, **838** are essentially below the implant **800** as shown in FIG. **86**. Extending upwardly from the vertebrae **836**, **838**, and between the first and second wings **810**, **824**, are the upper and lower spinous processes **840**, **842**. It is to be understood that in a preferred embodiment, the fit of the implant between the spinous processes can be such that the wings do not touch the spinous processes, as shown in FIG. **86**, and be within the spirit and scope of the invention.

[0223] The implant **800** includes, as assembled, an upper saddle **844** and the lower saddle **846**. The upper saddle **844** has an upper width identified by the dimension “UW”. The lower saddle **846** has a lower width identified by the dimension “LW”. In a preferred embodiment, the upper width is greater than the lower width. In other embodiments, the “UW” can be smaller than the “LW” depending on the anatomical requirements. The height between the upper and lower saddles **844**, **846** is identified by the letter “h”. These dimensions are carried over into FIG. **87** which is a schematic representation of the substantially trapezoidal shape which is formed between the upper and lower saddles. The table below gives sets of dimensions for the upper width, lower width, and height as shown in FIG. **87**. This table includes dimensions for some variations of this embodiment.

TABLE

Variation	1	2	3
Upper width	8	7	6
Lower width	7	6	5
Height	10	9	8

For the above table, all dimensions are given in millimeters.

[0224] For purposes of surgical implantation of the implant **800** into a patient, the patient is preferably positioned on his side (arrow **841** points up from an operating table) and placed in a flexed (tucked) position in order to distract the upper and lower vertebrae.

[0225] In a preferred procedure, a small incision is made on the midline of the spinous processes. The spinous processes are spread apart or distracted with a spreader. The incision is spread downwardly toward the table, and the distracting unit **802** is preferably inserted upwardly between the spinous processes **840** and **842** in a manner that maintains the distraction of spinous processes. The distracting unit **802** is urged upwardly until the distracting or bulbous end **808** and the slot **806** are visible on the other wide of the spinous process. Once this is visible, the incision is spread upwardly away from the table and the retaining unit or second wing **824** is inserted into the slot **806** and the screw **822** is used to secure the second wing in position. After this had occurred, the incisions can be closed.

[0226] An alternative surgical approach requires that small incisions be made on either side of the space located

between the spinous processes. The spinous processes are spread apart or distracted using a spreader placed through the upper incision. From the lower incision, the distracting unit **802** is preferably inserted upwardly between the spinous processes **840** and **842** in a manner that urges the spinous processes apart. The distracting unit **802** is urged upwardly until the distracting or bulbous end **808** and the slot **806** are visible through the second small incision in the patient’s back. Once this is visible, the retaining unit or second wing **824** is inserted into the slot **806** and the screw **822** is used to secure the second wing in position. After this has occurred, the incisions can be closed.

[0227] The advantage of either of the above present surgical procedures is that a surgeon is able to observe the entire operation, where he can look directly down onto the spinous processes as opposed to having to view the procedure from positions which are to the right and to the left of the spinous processes. Generally, the incision is as small as possible and the surgeon is working in a bloody and slippery environment. Thus, an implant that can be positioned directly in front of a surgeon is easier to insert and assemble than an implant which requires the surgeon to shift from side to side. Accordingly, a top-down approach, as an approach along a position to anterior line is preferred so that all aspects of the implantation procedure are fully visible to the surgeon at all times. This aides in the efficient location of (i) the distracting unit between the spinous processes, (ii) the retaining unit in the distracting unit, and (iii) finally the set screw in the distracting unit.

[0228] FIG. **80a** shows an alternative embodiment of the distracting unit **802a**. This distracting unit **802a** is similar to distracting unit **802** in FIG. **80** with the exception that the bulbous end **808a** is removable from the rest of the distracting body **804a** as it is screwed into the threaded bore **809**. The bulbous end **808a** is removed once the distracting unit **802a** is positioned in the patient in accordance with the description associated with FIG. **86**. The bulbous end **808a** can extend past the threaded bore **820** by about 1 cm in a preferred embodiment.

[0229] Another embodiment of the invention is shown in FIGS. **88**, **89**, **90** and **91**. In this embodiment, the implant is identified by the number **900**. Other elements of implant **900** which are similar to implant **800** are similarly numbered but in the 900 series. For example, the distracting unit is identified by the number **902** and this is in parallel with the distracting unit **802** of the implant **800**. The distracting body is identified by the number **904** in parallel with the distracting body **804** of the implant **800**. Focusing on FIG. **90**, the distracting unit **902** is depicted in a perspective view. The distracting unit includes slot **906** which is wider at the top than at the bottom. The reason for this is that the wider upper portion of the slot **906**, which is wider than the second wing **924** (FIG. **89**), is used to allow the surgeon to easily place the second wing **924** into the slot **906** and allow the wedge-shaped slot **906** to guide the second wing **924** to its final resting position. As can be see in FIG. **91**, in the final resting position, the largest portion of the slot **906** is not completely filled by the second wing **924**.

[0230] The end **908** of implant **900** is different in that it is more pointed, having sides **909** and **911** which are provided at about 45.degree. angles (other angles, such as by way of example only, from about 30.degree. to about 60.degree. are

within the spirit of the invention), with a small flat tip **913** so that the body **904** can be more easily urged between the spinous processes.

[0231] The distracting unit **902** further includes a tongue-shaped recess **919** which extends from the slot **906**. Located in the tongue-shaped recess is a threaded bore **920**.

[0232] As can be seen in FIG. **89**, a second wing **924** includes a tongue **948** which extends substantially perpendicular thereto and between the upper and lower portions **926**, **928**. The tab **948** includes a bore **4950**. With the second wing **924** positioned in the slot **906** of the distracting unit **902** and tab **948** positioned in recess **919**, a threaded set screw **922** can be positioned through the bore **4950** and engage the threaded bore **920** in order to secure the second wing or retaining unit **924** to the distracting unit **902**. The embodiment **900** is implanted in the same manner as embodiment **800** previously described. In addition, as the bore **922** is substantially perpendicular to the distracting body **904** (and not provided at an acute angle thereto), the surgeon can even more easily secure the screw in place from a position directly behind the spinous processes.

[0233] Still a further embodiment of the invention is depicted in FIGS. **92**, and **92a**. In this embodiment, the implant **1000** as can be seen in FIG. **92a** includes a central elongated body **1002** which has positioned at one end thereof a first wing **1004**. Wing **1004** is similar to the first wing previously described with respect to the embodiment of FIG. **88**. Bolt **1006** secures wing **1004** to body **1002** in this embodiment. Bolt **1006** is received in a bore of the body **1002** which is along the longitudinal axis **1008** of body. It is to be understood that in this embodiment, the first unit is defined by the central body **1002**, the first wing **1004**, and the guide **1010**.

[0234] Alternatively, the first wing can be secured to the central body with a press fit and detent arrangement as seen in FIG. **93c**. In this arrangement, the first wing has a protrusion **1040** extending preferably about perpendicularly from the first wing, with a flexible catch **1042**. The protrusion and flexible catch are press fit into a bore **1044** of the central body with the catch received in a detent **1046**.

[0235] In yet another alternative embodiment, the first wing can be designed as shown in FIG. **93d** with the protrusion directed substantially parallel to the first wing from a member that joins the first wing to the protrusion. Thus in this embodiment, the first wing is inserted into the body along the same direction as the second wing is inserted.

[0236] Positioned at the other end of the central body **1002** is a guide **1010**. In this particular embodiment, guide **1010** is essentially triangularly-shaped so as to be a pointed and arrow-shaped guide. Alternatively, guide **1010** could be in the shape of a cone with lateral truncated sides along the longitudinal axis **1008**. Guide **1010** includes a recess **1012** having a threaded bore **1014**. Recess **1012** is for receiving a second wing **1032** as will be described hereinbelow.

[0237] Additionally, it is also to be understood that the guide **1010** can be bulbous, cone-shaped, pointed, arrow-shaped, and the like, in order to assist in the insertion of the implant **1000** between adjacent spinous processes. It is advantageous that the insertion technique disturb as little of the bone and surrounding tissue or ligaments as possible in order to (1) reduce trauma to the site and facilitate early healing, and (2) not destabilize the normal anatomy. It is to be noted that with the present embodiment, there is no requirement to remove any of the bone of the spinous

processes and depending on the anatomy of the patient, there may be no requirement to remove or sever ligaments and tissues immediately associated with the spinous processes.

[0238] The implant **1000** further includes a sleeve **1016** which fits around and is at least partially spaced from the central body **1002**. As will be explained in greater detail below, while the implant may be comprised of a bio-compatible material such as titanium, the sleeve is comprised preferably of a super-elastic material which is by way of example only, a nickel titanium material (NiTi), which has properties which allow it to withstand repeated deflection without fatigue, while returning to its original shape. The sleeve could be made of other materials, such as for example titanium, but these materials do not have the advantages of a super-elastic material.

[0239] FIG. **93a** is a cross-section through the implant **1000** depicting the central body **1002** and the sleeve **1016**. As can be seen from the cross-section of FIG. **93a** in a preferred embodiment, both the central body **1002** and the sleeve **1016** are substantially cylindrical and oval or elliptically-shaped. An oval or elliptical shape allows more of the spinous process to be supported by the sleeve, thereby distributing the load between the bone and the sleeve more evenly. This reduces the possibility of fracture to the bone or bone resorption. Additionally, an oval or elliptical shape enhances the flexibility of the sleeve as the major axis of the sleeve, as described below, is parallel to the longitudinal direction of the spinous process. However, other shapes such as round cross-sections can come within the spirit and scope of the invention.

[0240] In this particular embodiment, the central body **1002** includes elongated grooves **1018**, along axis **1008**, which receives elongated spokes **1020** extending from the internal surface of the cylinder **1016**.

[0241] In a preferred embodiment, both the cross-section of the central body and the sleeve have a major dimension along axis **1022** and a minor dimension along axis **1024** (FIG. **93a**). The spokes **1020** are along the major dimension so that along the minor dimension, the sleeve **1016** can have its maximum inflection relative to the central body **1002**. It is to be understood that the central body along the minor dimension **1024** can have multiple sizes and can, for example, be reduced in thickness in order to increase the ability of the sleeve **1016** to be deflected in the direction of the central body **1002**.

[0242] Alternatively as can be seen in FIG. **93b**, the central body **1002** can include the spokes **1020** and the sleeve **1016** can be designed to include the grooves **1018** in order to appropriately space the sleeve **1016** from the central body **1002**.

[0243] In other embodiments, the sleeve can have minor and major dimensions as follows:

Minor Dimension	Major Dimension
6 mm	10 mm
8 mm	10.75 mm
12 mm	14 mm
6 mm	12.5 mm

-continued

Minor Dimension	Major Dimension
8 mm	12.5 mm
10 mm	12.5 mm

[0244] In one preferred embodiment, said sleeve has a cross-section with a major dimension and a minor dimension and said major dimension is greater than said minor dimension and less than about two times said minor dimension. In said embodiment, said guide has a cross-section which is adjacent to said sleeve with a guide major dimension about equal to said sleeve major dimension and a guide minor dimension about equal to said sleeve minor dimension. Further in said embodiment, said guide extends from said central body with a cross-section which reduces in size in a direction away from said central body.

[0245] In another preferred embodiment, said guide is cone-shaped with a base located adjacent to said sleeve. Further, said guide has a base cross-section about the same as the oval cross-section of said sleeve.

[0246] Thus, from the above, it is evident that preferably a major dimension of the sleeve correspond with a major dimension of the central body and a minor dimension of the sleeve corresponds with a minor dimension of the central body. Additionally, it is evident that the major dimension of the sleeve 1016 is substantially perpendicular to a major dimension of the first wing 1004 along longitudinal axis 1030 (FIG. 92a). This is so that as discussed above, when the implant 1000 is properly positioned between the spinous processes, a major portion of the sleeve comes in contact with both the upper and lower spinous processes in order to distribute the load of the spinous processes on the sleeve 1016 during spinal column extension.

[0247] As indicated above, the preferred material for the sleeve 1016 is a super-elastic material and more preferably one comprised of an alloy of nickel and titanium. Such materials are available under the trademark Nitinol. Other super-elastic materials can be used as long as they are bio-compatible and have the same general characteristics of super-elastic materials. In this particular embodiment, a preferred super-elastic material is made up of the following composition of nickel, titanium, carbon, and other materials as follows:

Nickel	55.80% by weight
Titanium	44.07% by weight
Carbon	<0.5% by weight
Oxygen	<0.5% by weight

[0248] In particular, this composition of materials is able to absorb about 8% recoverable strain. Of course, other materials which can absorb greater and less than 8% can come within the spirit and scope of the invention. This material can be repeatedly deflected toward the central body and returned to about its original shape without fatigue. Preferably and additionally, this material can withstand the threshold stress with only a small amount of initial deforming strain and above the threshold stress exhibit substantial

and about instantaneous deformation strain which is many times the small amount of initial deforming strain. Such a characteristic is demonstrated in FIG. 118 where it is shown that above a certain threshold stress level, deformation strain is substantially instantaneous up to about 8%. FIG. 118 shows a loading and unloading curve between stress and deformation strain for a typical type of super-elastic material as described above.

[0249] Preferably, the above super-elastic material is selected to allow deformation of up to about, by way of example only, 8%, at about 20 lbs. to 50 lbs. force applied between a spinous processes. This would cause a sleeve to deflect toward the central body absorbing a substantial amount of the force of the spinous processes in extension. Ideally, the sleeves are designed to absorb 20 lbs. to 100 lbs. before exhibiting the super-elastic effect (threshold stress level) described above. Further, it is possible, depending on the application of the sleeve and the anatomy of the spinal column and the pairs of spinous processes for a particular individual, that the sleeve can be designed for a preferable range of 20 lbs. to 500 lbs. of force before the threshold stress level is reached. Experimental results indicate that with spinous processes of an older individual, that at about 4400 pounds force, the spinous process may fracture. Further, such experimental results also indicate that with at least 100 pounds force, the spinous process may experience some compression. Accordingly, ideally the super-elastic material is designed to deform or flex at less than 100 pounds force.

[0250] In a preferred embodiment, the wall thickness of the sleeve is about 1 mm or $\frac{49}{1000}$ of an inch (0.040 in.). Preferably the sleeve is designed to experience a combined 1 mm deflection. The combined 1 mm deflection means that there is $\frac{1}{2}$ mm of deflection at the top of the minor dimension and a $\frac{1}{2}$ mm deflection at the bottom of the minor dimension. Both deflections are toward the central body.

[0251] In a particular embodiment where the sleeve is more circular in cross-section, with an outer dimension of 0.622 in. and a wall thickness of 0.034 in., a 20 lb. load causes a 0.005 in. deflection and a 60 lb. load causes a 0.020 in. deflection (approximately $\frac{1}{2}$ mm). A 100 lb. load would cause a deflection of about 0.04 in. or approximately 1 mm.

[0252] Thus in summary, the above preferred super-elastic material means that the sleeve can be repeatedly deflected and returned to about its original shape without showing fatigue. The sleeve can withstand a threshold stress with a small amount of deforming strain and at about said threshold stress exhibit about substantially instantaneous deformation strain which is many times the small amount of the forming strain. In other words, such super-elastic qualities mean that the material experiences a plateau stress where the material supports a constant force (stress) over very large strain range as exhibited in FIG. 118.

[0253] It is to be understood that for this particular embodiment, bar stock of the super-elastic material is machined into the appropriate form and then heat treated to a final temperature to set the shape of the material by increasing the temperature of the material to 932° F. and holding that temperature for five (5) minutes and then quickly quenching the sleeve in water. It is also to be understood that preferably the present nickel titanium super-elastic alloy is selected to have a transition temperature A, of about 59° Fahrenheit (15° C.). Generally for such devices

the transition temperature can be between 15° C. to 65° C. (59° F. to 149° F.), and more preferably 10° C. to 40° C. (50° F. to 104° F.). Preferably, the material is maintained in the body above the transition temperature in order to exhibit optimal elasticity qualities.

[0254] Alternatively, and preferably, the sleeve can be fabricated by wire Electrical Discharge Machining (EDM) rather than machined. Additionally, the sleeve can be finished using a shot blast technique in order to increase the surface strength and elasticity of the sleeve.

[0255] Top and side views of the second wing 1032 are shown in FIGS. 94 and 95. Second wing 1032 as in several past embodiments includes a tab 1034 with a bore 1036 which aligns with the bore 1014 of the guide 1010. In this particular embodiment, the second wing 1032 includes a cut-out 1038 which is sized to fit over the guide 1010, with the tab 1034 resting in the recess 1012 of the guide 1010.

[0256] An alternative configuration of the second wing 1032 is depicted in FIG. 94a. In this configuration, the second wing 1032 is held at acute angle with respect to the tab 1034. This is different from the situation in the embodiment of FIGS. 94 and 95 where the second wing is substantially perpendicular to the tab. For the embodiment of the second wing in FIG. 94a, such embodiment will be utilized as appropriate depending on the shape of the spinous processes.

[0257] With respect to the alternative second wing 1032 depicted in FIGS. 94b and 95a, elongated tab 1034 has a plurality of closely positioned bores 1036. The bores, so positioned, appear to form a scallop shape. Each individual scallop portion of the bore 1036 can selectively hold the bolt in order to effectively position the second wing 1032 in three different positions relative to the first wing 1004. The cut-out 1038 (FIG. 95a of this alternative embodiment) is enlarged over that of FIG. 95 as in a position closest to the first wing 1004, the second wing 1032 is immediately adjacent and must conform to the shape of the sleeve 1016.

[0258] Implant 1050 of FIG. 97 is similar to the implant 1000 in FIG. 92 with the major difference being that a second wing is not required. The implant 1050 includes a central body as does implant 1000. The central body is surrounded by a sleeve 1016 which extends between a first wing 1004 and a guide 1010. The guide 1010 in this embodiment is substantially cone-shaped without any flats and with no bore as there is no need to receive a second wing. The sleeve and the central body as well as the first wing and guide act in a manner similar to those parts of the implant 1000 in FIG. 92. It is to be understood a cross-section of this implant 1050 through sleeve 1016 can preferably be like FIG. 93a. This particular embodiment would be utilized in a situation where it was deemed impractical or unnecessary to use a second wing. This embodiment has the significant advantages of the sleeve being comprised of super-elastic alloy materials as well as the guide being utilized to guide the implant between spinous processes while minimizing damage to the ligament and tissue structures found around the spinous processes.

[0259] Implant 1060 is depicted in FIG. 98. This implant is similar to the implants 1000 of FIG. 92 and the implant 1050 of FIG. 97, except that this implant does not have either first or second wings. Implant 1060 includes a sleeve

1016 which surrounds a central body just as central body 1002 of implant 1000 in FIG. 93. It is to be understood that a cross-section of this implant 1060 through sleeve 1016 can preferably be like FIG. 93a. Implant 1060 includes a guide 1010 which in this preferred embodiment is cone-shaped. Guide 1010 is located at one end of the central body. At the other end is a stop 1062. Stop 1062 is used to contain the other end of the sleeve 1016 relative to the central body. This embodiment is held together with a bolt such as bolt 1006 of FIG. 93 that is used for the immediate above two implants. For the implant 1060 of FIG. 98, such a device would be appropriate where the anatomy between the spinous processes was such that it would be undesirable to use either a first or second wing. However, this embodiment affords all the advantageous described hereinabove (FIGS. 92 and 97) with respect to the guide and also with respect to the dynamics of the sleeve.

[0260] FIGS. 99 and 100 depict an implant system 1070. Implant system 1070 includes a sleeve 1072 which is similar to and has the advantageous of sleeve 1016 of the embodiment in FIG. 92. Sleeve 1072 does not, however, have any spokes. Additionally, implant system 1070 includes an insertion tool 1074. Insertion tool 1074 includes a guide 1076 which in a preferred embodiment is substantially cone-shaped. Guide 1076 guides the insertion of the sleeve 1072 and the insertion tool 1074 between adjacent spinous processes. The insertion tool 1074 further includes a central body 1078, a stop 1080, and a handle 1082. The guide 1076 at its base has dimensions which are slightly less than the internal dimensions of the sleeve 1074 so that the sleeve can fit over the guide 1076 and rest against the stop 1080. The tool 1074 with the guide 1076 is used to separate tissues and ligaments and to urge the sleeve 1072 in the space between the spinous processes. Once positioned, the guide insertion tool 1074 can be removed leaving the sleeve 1072 in place. If desired, after the sleeve is positioned, position maintaining mechanisms such as springy wires 1084 made out of appropriate material such as the super-elastic alloys and other materials including titanium, can be inserted using a cannula through the center of the sleeve 1072. Once inserted, the ends of the retaining wires 1084 (FIG. 99) extend out of both ends of the sleeve 1072, and due to this springy nature, bent at an angle with respect to the longitudinal axis of the sleeve 1072. These wires help maintain the position of the sleeve relative to the spinous processes.

[0261] Another embodiment of the invention can be seen in FIG. 101 which includes implant 1100. Implant 1100 has many similar features that are exhibited with respect to implant 1000 in FIG. 92. Accordingly, elements with similar features and functions would be similarly numbered. Additionally, features that are different from implant 1100 can be, if desired, imported into and become a part of the implant 1000 of FIG. 92.

[0262] As with implant 1000, implant 1100 includes a central body 1002 (FIG. 102) with a first wing 1004 and a bolt 1006 which holds the first wing and the central body together. In this particular embodiment, the central body is made in two portions. The first portion 1102 is in the shape of a truncated cone with an oval or elliptical base and a second portion 1104 includes a cylindrical central portion with a distal end in the shape of a truncated cone 1103 with an oval or elliptical base. In addition, in this particular embodiment, formed with the central body is the guide 1010

which has an oval or elliptical base. Bolt **1006** is used to secure the first wing through the second portion **1104** with the first portion **1102** held in-between. In this particular embodiment, the guide **1010** in addition to including recess **1012** and bore **1014** includes a groove **1106** which receives a portion of the second wing **1032**.

[0263] In this particular embodiment, the sleeve **1016** is preferably oval or elliptical in shape as can be seen in FIG. **102a**. The central body can be oval, elliptical or circular in cross-section, although other shapes are within the spirit and scope of the invention. The sleeve **1016** held in position due to the fact that the truncated conical portion **1102** and the corresponding truncated conical portion **1103** each have a base that is elliptical or oval in shape. Thus, the sleeve is held in position so that preferably the major dimension of the elliptical sleeve is substantially perpendicular to the major dimension of the first wing. It is to be understood that if the first wing is meant to be put beside the vertebrae so that the first wing is set at an angle other than perpendicular with respect to the vertebrae and that the sleeve may be held in a position so that the major dimension of the sleeve is at an angle other than perpendicular to the major dimension of the first wing and be within the spirit and scope of the invention. This could be accomplished by tightening bolt **1006** with the first wing **1004** and sleeve **1016** so positioned. In such a configuration, the major dimension of the sleeve would be preferably positioned so that it is essentially parallel to the length of the adjacent spinous processes. So configured, the elliptical or oval shape sleeve would bear and distribute the load more evenly over more of its surface.

[0264] It is to be understood that the sleeve in this embodiment has all the characteristics and advantages described hereinabove with respect to the above-referenced super-elastic sleeves.

[0265] The second wing as discussed above, can come in a variety of shapes in order to provide for variations in the anatomical form of the spinous processes. Such shapes are depicted in FIGS. **103**, **104**, **105**, **106**, and **107**. In each configuration, the second wing **1032** has an upper portion **1108** and a lower portion **1110**. In FIG. **104**, the lower portion is thicker than the upper portion in order to accommodate the spinous process, where the lower spinous process is thinner than the upper spinous process. In FIG. **105**, both the upper and lower portions are enlarged over the upper and lower portions of FIG. **103** to accommodate both the upper and lower spinous processes being smaller. That is to say that the space between the upper and lower portions of the first and second wings are reduced due to the enlarged upper and lower portions of the second wing.

[0266] Alternative embodiments of second wings, as shown in FIGS. **104** and **105**, are depicted in FIGS. **106** and **107**. In these FIGS. **106** and **107**, the second wing **1032** accommodates the same anatomical shape and size of the spinous processes as does the second wing in FIGS. **104** and **105** respectively. However, in the embodiments of the second wing **1032** of FIGS. **106** and **107**, substantial masses have been removed from the wings. The upper and lower portions **1108** and **1110** are essentially formed or bent in order to extend from the central portion **1112** of the second wing **1032**.

[0267] It is to be understood that in this embodiment, if desired, the second wing may not have to be used, depending

on the anatomy of the spinal column of the body, and this embodiment still has the significant advantages attributable to the guide **1010** and the functionality of the sleeve **1016**.

[0268] The implant **1120** as shown in FIGS. **108** and **109**, is similar to implant **1100** which is in turn similar to implant **1000**. Such similar details have already been described above and reference here is made to the unique orientation of the first and second wings **1122** and **1124**. These wings have longitudinal axis **1126** and **1128** respectfully. As can be seen in these figures, the first and second wings **1122**, **1124** have been rotated so that they both slope inwardly and if they were to continue out of the page of the drawing of FIG. **108**, they would meet to form an A-frame structure as is evident from the end view of FIG. **109**. In this particular embodiment, as can be seen in FIGS. **109** and **110**, the tab **1034** is provided an acute angle to the remainder of the second wing **1124**. Further, the groove **1018** formed in the implant is sloped in order to accept the second wing **1124**. Accordingly, this present implant **1120** is particularly suited for an application where the spinous process is wider adjacent to the vertebral body and then narrows in size at least some distance distally from the vertebral body. It is to be understood that a cross-section of this implant **1120** through sleeve **1016** can preferably be like FIG. **93a**.

[0269] An additional embodiment of the implant **1150** is shown in FIG. **111**. Implant **1150** has features similar to those described with respect to FIG. **94b**.

[0270] Implant **1150** includes a central body **1152** with a first wing **1154**, where central body **1152** includes elongated groove **1156** which extends to the guide **1158**. A screw **1160** is received in a threaded bore located in the elongated groove **1156**.

[0271] The second wing **1162** includes a central body **1164** which is substantially perpendicular to the second wing **1162**.

[0272] The central body **164** includes a plurality of bores **1166** provided therein. These bores are formed adjacent to each other in order to define a plurality of scallops, each scallop capable of retaining bolt **1160** therein. As can be seen in FIG. **114**, the second wing includes a cut-out **1168** such that with the central body **1164** of the second wing received in the groove **1156** of the central body associated with the first wing, the remainder of the second wing is received over the central body **1152** of the implant **1150**. With this implant **1150**, the distance between the first and second wings can be adjusted by selectively placing the bolt **1160** through one of the five specified bores defined by the scalloped plurality of bores **1166**. Accordingly, FIG. **112** depicts the implant where the first and second wings are widest apart in order to accommodate spinous processes of greater thickness. FIG. **111** shows the middle position between the first and second wings in order to accommodate average size spinous processes.

[0273] It is to be understood that preferably during the surgical process, the central body **1152** is urged between spinous processes. After this has occurred, the second wing is guided by the other sides of the spinous processes from a path which causes the plane of the second wing to move substantially parallel to the plane of the first wing until the central body **1164** associated with the second wing **1162** is received in the groove of **1156** of the central body **1152**

associated with the first wing **1154**. After this has occurred, the bolt **1160** is positioned through aligned bores associated with the second wing **1162** and the central body **1152** in order to secure the second wing to the central body.

[0274] While embodiment **1150** does not depict a sleeve such as sleeve **1016**, such a sleeve **1016** could be placed over body **1152** and be within the spirit of the invention.

[0275] Implant **1200** of the invention is depicted in FIGS. **119a** and **119b**. This implant includes the first wing **1202** and sleeve **1204** and a guide **1206**. An alternative to this embodiment further includes, as required, second wing **1208** as depicted in FIGS. **120a** and **120b**.

[0276] As can be seen in FIG. **121a** and **121b**, the first wing **1202** includes a bore which receives a central body **1210**. Preferably, the central body is pressed fit through the bore of the first wing although it is to be understood that other securing mechanisms such as through the use of threads and still other mechanisms can be used to accomplish this task. Additionally, in this particular embodiment first and second pins **1212** extend from the first wing **1202**, each along an axis which is substantially parallel to the longitudinal axis **1214** of the central body **1210**. In this particular embodiment, the distal end **1216** of the central body **1210** is threaded in order to be coupled to the guide **1206**.

[0277] As can be seen in FIGS. **122a**, **122b** and **122c**, the guide **1206** in this particular embodiment is pointed in order to allow the implant to be inserted between, and if necessary distract, adjacent spinous processes. The guide **206** includes a threaded bore **1218** which is designed to accept the threaded end **1216** of the central body **1210** in order to secure the guide to the central body and additionally for purposes of retaining the sleeve between the guide **1206** and the first wing **1202**.

[0278] As can be seen in FIG. **123a** the sleeve **1204** is preferably cylindrical, and oval or elliptical in shape in cross-section. It is to be understood that sleeve **1204** can have other shapes as described throughout the specification and be within the spirit and scope of the invention. In this particular embodiment, sleeve **1204** has at least one major diameter and one minor diameter in cross-section. Sleeve **1204** includes a central bore **1220** which extends the length of sleeve **1204** and curve grooves **1222** which are formed about central bore **1220** and extend only part way into the body of the sleeve. In this particular embodiment, the curved grooves **1222** describe an arc of about 60.degree. It is to be understood that in other embodiment, this arc can be less than 60.degree. and extend past 120.degree.

[0279] The sleeve **1204** is received over the central body **1210** of the implant **1200** and can rotate thereon about the longitudinal axis **1214** of the central body **1210**. When this particular embodiment is assembled, the grooves **1222** have received therein the pins **1212** that extend from the first wing **1202**. Accordingly, the pins inserted in the grooves **1222** assist in the positioning of the sleeve relative to the remainder of the implant **1200**. With the pins **1212** received in the curved grooves **1222**, the pins limit the extent of the rotation of the sleeve about the central body and relative to the first wing.

[0280] As can be seen in FIGS. **124a**, **124b**, and **124c**, the sleeve is free to rotate relative to the longitudinal axis of the

central body **1210** and thus relative to the first wing **1202** of the embodiment shown in FIGS. **119a** and **119b**. The sleeve can rotate relative to a second wing **1208**, when the second wing is utilized in conjunction with the embodiment of FIGS. **119a** and **119b**. The pins limit the rotation of the sleeve. In an alternative embodiment, the pins are eliminated so that the sleeve can rotate to any position relative to the first wing.

[0281] It is to be understood that the sleeve can be comprised of biologically acceptable material such as titanium. Additionally, it can be comprised of super-elastic material such as an alloy of nickel and titanium, much as described hereinabove with respect to other embodiments.

[0282] The great advantage of the use of the sleeve **1204** as depicted in the embodiment of FIGS. **119a** and **119b** is that the sleeve can be rotated and repositioned with respect to the first wing **1202**, and/or the second wing **1208** should the second wing be used in the embodiment, in order to more optimally position the implant **1200** between spinous processes. It is to be understood that the cortical bone or the outer shell of the spinous processes is stronger at an anterior position adjacent to the vertebral bodies of the vertebra that at a posterior position distally located from the vertebral bodies. Accordingly, there is some advantage of having the implant **1200** placed as close to the vertebral bodies as is possible. In order to facilitate this and to accommodate the anatomical form of the bone structures, as the implant is inserted between the vertebral bodies and urged toward the vertebral bodies, the sleeve **1204** can be rotated relative to the wings, such as wing **1202**, so that the sleeve is optimally positioned between the spinous processes, and the wing **1202** is optimally positioned relative to the spinous processes. Without this capability, depending on the anatomical form of the bones, it is possible for the wings to become somewhat less than optimally positioned relative to the spinous processes.

[0283] FIGS. **125**, **126** and **127** depict three alternative embodiments of the invention as can be seen through a line parallel to line **124-124** of FIG. **119b**.

[0284] In FIG. **125**, the sleeve **1204** is rotatable about central body **1210**. In this embodiment, however, the sleeve **1204** design does not include the grooves **1222** as previously depicted in the embodiment shown in FIG. **123a**. Thus, without pins, the sleeve is completely free to rotate about the central body **1210**.

[0285] An alternative embodiment is shown in FIG. **126**. In this embodiment, the sleeve **1204** is essentially a thin wall cylinder which is spaced from the central body **1210**. Sleeve **1204** is free to move relative to central body **1210**. Sleeve **1204** can rotate relative to central body **1210**. In addition, sleeve **1204** can take a somewhat cocked or skewed position relative to central body **1210**.

[0286] A further embodiment, it is shown in FIG. **127**. This embodiment is somewhat similar to the embodiment shown in FIG. **126** except that in this case, several pins project from the first wing in order to somewhat limit and restrict the motion of the sleeve **1204**. As shown in FIG. **127**, four pins are depicted. It is to be understood however that such an embodiment can include one, two, three, four or more pins and be within the spirit and scope of the invention. It is to be understood that if the embodiment is used with a

second wing, that similar pins can extend from the second wing. However, in the embodiment using a second wing, the pins would preferably be somewhat flexible so that they could snap into the inside of the sleeve **1204** as the second wing is inserted relative to the central body and secured in place. In the embodiment shown in FIG. **127**, the sleeve **1204** is free to rotate about the longitudinal axis of the central body **1210** and is somewhat restricted in this motion and its ability to become skewed relative to the longitudinal axis of the central body by the pins.

[**0287**] The embodiments of FIG. **128** is an advantageous alternative to that of FIG. **93a**. In this embodiment, the central body **1002** is similar to that as shown in FIG. **93a**. The sleeve **116** is comprised of two sleeve portions **1016a** and **1016b**. The sleeve portions are preferably formed from flat stock material which is substantially easier to form than having the sleeve formed or machined from solid bar stock material. A further advantage of the sleeve **1016**, if formed of super-elastic material, is that the sleeve can be formed in a manner which optimizes the super-elastic characteristics of such material in order to enhance its ability to repeatedly deflect under load. In this particular embodiment, the sleeve portions **1016a** and **1016b** are somewhat C-shaped and then after being formed, are snapped into the grooves of the central body **1002**.

[**0288**] An alternative embodiment of the invention is shown in FIG. **129**. This embodiment is most favorably used with the embodiment of FIG. **119a** and **119b**. In this particular embodiment, the sleeve **1204** is designed to rotate about the central body **1210**. Sleeve **1204** includes a central member **1230** which includes a bore that receives the central body **1210**. The central member **1230** is rotatable about the central body **1210** of the implant **1200**. The central member **1230** includes first and second grooves **1232** and **1234**. These grooves can receive C-shaped sleeve members **1204a** and **1204b**. These C-shaped sleeve members are similar in construction and design to the C-shaped sleeve members shown above with respect to FIG. **128**. These sleeve members can be snapped into position relative to the central member **1230** of the sleeve **1204**. It is to be understood that other mechanisms can be used to secure the C-shaped sleeve member relative to the central member of the sleeve and be within the spirit and scope of the invention. Further, it is to be understood that the sleeve members **1204a** and **1204b** can be formed from a single flat stock material such that one of the grooves **1232** and **1234** receives continuous piece of flat material which has been appropriately bent and the other grooves receives two ends of the sleeve.

[**0289**] From the above, it is evident that the present invention can be used to relieve pain caused by spinal stenosis in the form of, by way of example only, central canal stenosis or foraminal (lateral) stenosis. These implants have the ability to flatten the natural curvature of the spine and open the neural foramen and the spacing between adjacent vertebra to relieve problems associated with the above-mentioned lateral and central stenosis. Additionally, the invention can be used to relieve pain associated with facet arthropathy. The present invention is minimally invasive and can be used on an outpatient basis.

[**0290**] The following description is presented to enable any person skilled in the art to make and use the invention. Various modifications to the embodiments described will be

readily apparent to those skilled in the art, and the principles defined herein can be applied to other embodiments and applications without departing from the spirit and scope of the present invention as defined by the appended claims. Thus, the present invention is not intended to be limited to the embodiments shown, but is to be accorded the widest scope consistent with the principles and features disclosed herein. To the extent necessary to achieve a complete understanding of the invention disclosed, the specification and drawings of all patents and patent applications cited in this application are incorporated herein by reference.

[**0291**] FIGS. **130A-130F** illustrate an embodiment of an apparatus, or implant **2100**, suitable for use with the method of this invention. The implant **2100** includes a first wing **2104**, a selectably expandable spacer **2150** and a lead-in tissue expander or distraction guide **2110**. The implant further includes, as required, a second wing **2132**. As can be seen in FIG. **130A**, a shaft **2102** extends from the first wing **2104** and is the body that connects the first wing to the distraction guide **2110**. Also, as can be seen in FIGS. **130A** and **130B**, the guide **2110** in this particular embodiment is pointed in order to allow the implant to be inserted between, and, if necessary, to distract adjacent spinous processes. In this particular embodiment, the guide **2110** has a wedge-shaped cross-section, expanding from the distal end **2111** to the area where the second wing **2132** can be optionally secured to the guide. FIGS. **130B** and **130C** illustrate an embodiment of the implant **2100** with only a first wing **2104**.

[**0292**] As required, implant **2100** can include a second wing **2132** which fits over the guide **2110** and is secured by a bolt **2130** placed through aperture **2134** of the second wing **2132** to the threaded bore **2112** located in the guide **2110**. As implanted, the first wing **2104** is located adjacent to first sides of the spinous processes and the second wing **2132** is located adjacent to second sides of the same spinous processes.

[**0293**] The spacer **2150** is rotatably mounted about a shaft **2102**. The spacer **2150** is positioned between the first wing **2104** and the guide **2110**. The tissue expander **2110** guides the spacer **2150** into position between the spinous process of adjacent vertebrae. The spacer **2150** includes a slotted sphere **2151** that when rotated is positioned along a lead-screw, expanding or collapsing the spacer.

[**0294**] FIGS. **130F**, **131A-B**, **132A-B**, and **133** illustrate a preferred embodiment of the spacer **2150** wherein the shape of the spacer **2150** is oval or elliptical in cross-section, although it can alternatively be circular or ovoid or race-track shaped in cross-section. It is to be understood that the spacer **2150** can have other shapes as described throughout the specification and be within the spirit and scope of the invention. In a preferred embodiment, the spacer **2150** includes a bore **2152** extending the length of the spacer **2150**. The bore **2152** of the spacer **2150** is received over the shaft **2102** of the implant **2100** so that, as described above, the spacer can be rotated about the shaft **2102**. In these embodiments, the spacer **2150** can have minor and major dimensions as follows:

Minor Dimension (116a)	Major Dimension (116b)
6 mm	10 mm
8 mm	10.75 mm
12 mm	14 mm
6 mm	12.5 mm
8 mm	12.5 mm
10 mm	12.5 mm

[0295] One advantage of the use of the spacer **2150**, as depicted in the embodiment of FIG. **130A**, is that the spacer **2150** can be partially rotated and repositioned with respect to the first wing **2104** in order to optimize positioning of the implant **2100** between spinous processes. It is to be understood that the cortical bone or the outer bone of the spinous processes is stronger at an anterior position adjacent to the vertebral bodies of the vertebra than at a posterior position distally located from the vertebral bodies. Also, biomechanically for load bearing, it is advantageous for the spacer **2150** to be close to the vertebral bodies. In order to facilitate this and to accommodate the anatomical form of the bone structures, as the implant is inserted between the spinous processes and/or urged toward the vertebral bodies, the spacer **2150** rotates relative to the wings, such as wing **2104**, so that the spacer **2150** is optimally positioned between the spinous processes, and the wing **2104** is optimally positioned relative to the spinous processes.

[0296] In another embodiment, the spacer **2150** has a cross-section with a major dimension and a minor dimension, wherein the major dimension is greater than the minor dimension, and, for example, less than about two times the minor dimension. It is to be understood that the spacer **2150** can be fabricated from somewhat flexible and/or deflectable material.

[0297] In this embodiment the spacer is made out of a polymer, more specifically, the polymer is a thermoplastic. Still more specifically, the polymer is a polyketone known as polyetheretherketone (PEEKTM). Still more specifically, the material is PEEK 450G, which is an unfilled PEEK approved for medical implantation available from Victrex of Lancashire, Great Britain. (Victrex is located at www.matweb.com or see Boedeker www.boedeker.com). Other sources of this material include Gharda located in Panoli, India (www.ghardapolymers.com).

[0298] The spacer **2150** can be formed by extrusion, injection, compression molding and/or machining techniques. This material has appropriate physical and mechanical properties and is suitable for carrying and spreading the physical load between the spinous process. For example, in this embodiment, the PEEK has the following approximate properties:

Density	1.3 g/cc
Rockwell M	99
Rockwell R	126
Tensile Strength	97 MPa
Modulus of Elasticity	3.5 GPa
Flexural Modulus	4.1 Gpa

[0299] It should be noted that the material selected may also be filled. For example, other grades of PEEK are also available and contemplated, such as 30% glass-filled or 30% carbon-filled, provided such materials are cleared for use in implantable devices by the FDA, or other regulatory body. Glass-filled PEEK reduces the expansion rate and increases the flexural modulus of PEEK relative to that which is unfilled. The resulting product is known to be ideal for improved strength, stiffness, or stability. Carbon-filled PEEK is known to enhance the compressive strength and stiffness of PEEK and lower its expansion rate. Carbon-filled PEEK offers wear resistance and load carrying capability.

[0300] In this embodiment, as described above, the spacer **2150** is manufactured from polyetheretherketone (PEEKTM), available from Victrex. As will be appreciated, other suitable similarly biocompatible thermoplastic or thermoplastic polycondensate materials that resist fatigue, have good memory, are flexible, and/or deflectable, have very low moisture absorption, and good wear and/or abrasion resistance, can be used without departing from the scope of the invention. The spacer can also be comprised of polyetherketoneketone (PEKK).

[0301] Other materials that can be used include polyetherketone (PEK), polyetherketoneetherketoneketone (PEKEKK), and polyetheretherketoneketone (PEKKK), and generally a polyaryletheretherketone. Further other polyketones can be used as well as other thermoplastics. The spacer can also be made of titanium.

[0302] Reference to appropriate polymers that can be used in the spacer can be made to the following documents, all of which are incorporated herein by reference. These documents include: PCT Publication WO 02/02158 A1, dated Jan. 10, 2002, entitled "Bio-Compatible Polymeric Materials;" PCT Publication WO 02/00275 A1, dated Jan. 3, 2002, entitled "Bio-Compatible Polymeric Materials;" and, PCT Publication WO 02/00270 A1, dated Jan. 3, 2002, entitled "Bio-Compatible Polymeric Materials."

[0303] Other materials such as Bionate®, polycarbonate urethane, available from the Polymer Technology Group, of Berkeley, Calif., may also be appropriate because of the good oxidative stability, biocompatibility, mechanical strength and abrasion resistance. Other thermoplastic materials and other high molecular weight polymers can be used.

[0304] A preferred embodiment of the spacer is illustrated in FIGS. **131A-134A**. In FIGS. **131A** and **131B** the spacer **2150** includes a first portion **2260** pivotably or rotatably coupled with a second portion **2261** by a hinge (shown in FIG. **133**). Both the first portion **2260** and the second portion have tapered distal ends that form an acute angle between the two portions. FIG. **131A** illustrates the acute angle **2265a** formed when the spacer **2150** is in the unexpanded position. The first portion **2260** has a bore **2252** through which the shaft **2102**, shown in FIG. **130A**, is received, connecting the first wing **2104** with the guide **2110** and connecting the spacer **2150** with the implant **2100**. The bore **2252** allows the spacer **2150** to partially rotate about the shaft **2102**. The second portion **2261** of the spacer **2150** also has a bore that is located behind and aligned with the bore **2252**, shown in FIG. **131A**. This bore is also received on the shaft **2102** so that both the first and second portions of the spacer **2150** can rotate about the shaft **2102**. A threaded screw **2253** protrudes through the angle **2265** a formed by the tapered distal ends

of the portions. The end of the threaded screw **2253** also has a bore that aligns with the bores of the first and second portions of the spacer **2150** and is received on the shaft **2102** and can rotate about the shaft **2102**. A slotted sphere **2151** is connected with the distal end of screw **2253**. In the least expanded position, the slotted sphere **2151** is at the farthest point of travel away from the proximal end of the screw **2253**, shown in FIG. **131A**.

[**0305**] FIG. **131B** illustrates the acute angle **2265b** formed when the spacer **2150** is in the fully expanded position. The slotted sphere **2151** is rotated such that the sphere travels toward the proximal end of the threaded screw **2253**. As the slotted sphere **2151** travels toward the proximal end of the screw **2253**, the sphere **2151** forces the tapered distal ends of the portions **2260**, **2261** apart. As the distal ends of the portions are forced apart, the first portion **2260** and the second portion **2261** rotate in opposite directions about a common hinge **2463** (shown in FIG. **133**), sliding along the contact surface **2262**. As the acute angle formed by the distal ends of the portions increases, the height of the spacer **2150** expands.

[**0306**] FIGS. **132A** and **132B** illustrate in cross-section the preferred embodiment of the selectably expandable spacer described in reference to FIGS. **131A** and **131B**. The slotted sphere **2151** has a threaded cavity for receiving the threaded screw **2253** when the sphere **2151** is rotated. The slotted sphere **2151** travels the distance **2351c** such that the distal end of the screw **2253** moves from position **2351a** to position **2351b** along the threaded cavity of the sphere when adjusted from an unexpanded to a fully expanded position. When rotated in the opposite direction, the slotted sphere **2151** moves away from the proximal end of the screw **2253**, collapsing the spacer **2150**. FIG. **132B** illustrates the spacer **2150** in a fully expanded position with the distal end of the screw **2253** at the maximum position **2351b** in the threaded cavity of the slotted sphere **2151**. It is to be understood that portions the **2260**, **2261** of the spacer **2150** can be biased to the closed position shown in FIG. **132A**. The biasing can be accomplished by a spring that is coiled in or about the bore of the spacer that receives the shaft **2102**. Such a spring would be connected to both of the portions **2260**, **2261** of the spacer **2150**.

[**0307**] The first and second portions of the spacer **2150** in combination, can have a cross-section that is elliptical, oval, ovoid, football-shaped, circular-shaped, rectangular with rounded ends (where the cross-section has two somewhat flattened surfaces and two rounded surfaces similar to the effect of a flattened ellipse) or race-track shaped. Further, the first and second portions can have different cross-sectional shapes relative to each other. At least the minor dimension (the height) of the spacer is between 6 mm and 14 mm. Typically, the minor outer dimension is one of 6 mm, 8 mm, 10 mm, 12 mm, and 14 mm. The different sizes and selectable expandability enable the spacer to accommodate different sized patients.

[**0308**] As discussed above, the spacer **2150** and its components, including either the first or second portions, or both, can be made of a number of materials. Suitable materials can include polymers, such as, for example, polyetheretherketone (PEEK™), as well as other materials described above, including titanium. Such materials can be deflectable and flexible depending on the configuration of the spacer **2150**.

[**0309**] Further, the deflectable or flexible material can have a graduated stiffness to help gradually distribute the load when the spinous processes place a force upon the exterior surface of the spacer. This can be accomplished by forming multiple layers of the deflectable or flexible material with decreasing stiffness or hardness from the center of the spacer outwardly. Alternatively, the material can have a higher stiffness or hardness in the center of the inner spacer.

[**0310**] Referring to FIG. **133**, the slotted sphere **2151** is positioned approximately equidistant from a first and second ends of the spacer **2150**, distributing the parting force of the sphere **2151** so as not to create disproportionate stress on either side of the spacer **2150**.

[**0311**] A hinge **2463** couples a first portion **2260** with a second portion **2261**, such that the two portions pivot about the hinge **2463**, expanding or collapsing the gap **2465**.

[**0312**] A perspective view is provided in FIG. **134A**, showing the clam-shape of the preferred embodiment of the spacer **2150**. The implant **2100** is positioned between the adjacent vertebrae so as to permit access to the slot **2554** from a posterior direction both during and after surgery. Post-surgery adjustment is made using a cannula inserted through the patient's back. Convenient access to the slot **2554** is important for reducing patient discomfort and procedure complication.

[**0313**] The bore **2252** provides a sleeve for the shaft **2102**, and also limits the rotation of the spacer **2150** about the shaft **2102**. Limiting the rotation of the spacer **2150** can be accomplished, for example, by providing a slot **2255** in the bore **2252** and a key on the shaft **2102**, or vice-versa. One of skill in the art can appreciate that different mechanisms and geometries can be used to limit spacer rotation. Reference is also made to a copending U.S. patent application Ser. No. 09/799,470, filed on Mar. 5, 2001, entitled "Spinal Implants, Insertion Instruments, and Methods of Use," (Atty Docket No. KLYC-1027 US1), which is incorporated herein by reference and which discloses an implant which has a spacer with a slot and an implantation tool that includes a probe that engages the slot in order to position the spacer relative to the implantation tool for desirable initial positioning of the space relative to the spinous processes. Such a mechanism can be used by itself or in addition to the above discussed keyway and key for purposes of positioning the sphere **2151** so that the height of the spacer **2150** can be selectively adjusted during the initial surgical procedure or, thereafter, should such adjustment be desirable due, for example, to the need for more distraction between the spinous processes.

[**0314**] FIG. **134B** depicts the back of another embodiment of the spacer **2150** of the implant **2100** of the invention. FIG. **134B** is similar to a back view of the embodiment depicted in FIG. **133**. In FIG. **134B**, the spacer **2150** includes the first and second portions **2260**, **2261**, respectively. The first portion includes a bore **2252** that receives the shaft **2102** and the second portion includes bore **2254** that also receives the shaft **2102**. In addition, the screw **2253** is shown with a portion of the sphere **2151** that is used to adjust the height of the spacer **2150**. The screw **2253** includes a bore **2257** that also receives the shaft **2102**. Thus, the first and second portions of the spacer and the screw are rotatable about the shaft.

[**0315**] One of skill in the art can also appreciate the different expansion mechanisms that can be employed to

expand the spacer 2150. For example, an expansion mechanism could include: pistons, ratchets, cams, jacks, or other machines. FIGS. 135A and 135B illustrate one alternative embodiment in which a jack 2651 is used to expand the spacer 2150. The jack 2651 is expanded or collapsed by rotating a slotted screw 2653, thereby increasing or decreasing the gap 2665. FIG. 135A shows the spacer 2150 in an unexpanded position with a narrow gap 2665a.

[0316] FIG. 135B illustrates another alternative embodiment utilizing a jack, whereby the hinge 2462 can allow for translation of the first and second portions in the y-direction as well as for rotation about the hinge 2462, thereby reducing the stresses on the side of the jack closest to the hinge caused by uneven compression when the gap 2665b expands. For the embodiment in FIGS. 135A and 135B any of the above devices for allowing the first portion of the spacer to move relative to the second portion of the spacer can be employed, as well as other known methods, and be within the spirit and scope of the invention.

[0317] The preferred method for inserting the implant between adjacent vertebrae is block-diagramed in FIG. 136. The method requires that the spine be surgically exposed. The implant is then inserted between the spinous processes, with the wedge shape of the guide forcing tissue apart to create room for the implant. Once the implant is in place, with the spacer between adjacent vertebrae, the profile of the implant is adjusted by expanding or collapsing the spacer using a tool for operating the expansion mechanism. The wound is then closed.

[0318] The implant can subsequently be readjusted with the insertion of a cannula through which a tool is inserted for operating the expansion mechanism.

[0319] Embodiments of the present invention relate to an interspinous process implant including a first wing for implant retention after placement, a spacer for maintaining and/or causing additional distraction, and a tissue expander for converting from a first position for insertion to a second position for retention of the implant after placement between adjacent spinous processes. In the second position, the tissue expander acts like a second wing to prevent displacement of the implant. The disclosed invention further claims a method for lateral insertion of the disclosed implant of the invention.

[0320] FIG. 137 shows a side view of an embodiment of an implant 3100 of the disclosed invention. The implant 3100 comprises a spacer 3016 that maintains the distraction of the spinous processes of adjacent vertebrae, once the spacer 3016 is positioned between the spinous processes 3012, 3014. The spacer 3016 can have various shapes including, by way of example only, a cylindrical shape, an elliptical shape, or tear-drop shape when viewed in cross-section substantially perpendicular to a longitudinal or elongated axis 3034 of the spacer 3016. The longitudinal axis 3034 is oriented from the left lateral to right lateral spine, when the implant 3100 is positioned in the spine.

[0321] The spacer 3016 has a first or proximal end 3018 and a second or distal end 3020. At the first end 3018, the spacer 3016 is connected with a first wing 3022. The first wing 3022 functions as a first retaining unit. That is, the first wing 3022 prevents displacement of the implant 3100 once the implant 3100 is positioned in the spine, with the spacer 3016 between adjacent spinous processes. From the first

wing 3022 extends a shaft 3017 upon which the rotatable spacer 3016 is rotatably mounted, so that the spacer 3016 can rotate independently from the first wing 3022 for positioning of both elements of the implant 3100. Alternatively, the first wing 3022 can be fixedly connected with, or integral to the spacer 3016.

[0322] The second end 3020 of the spacer 3016 is located adjacent to a tissue expander 3024. The tissue expander 3024 has a wedge-shaped first end 3026 that is distal to the spacer 3016, and a second end 3028 that is adjacent the spacer 3016. As discussed below, the tissue expander 3024 can be rotated about the axis 3034. When the tissue expander 3024 is rotated about the rotation axis 3034, it is converted from a first insertion position 3036 (shown in FIGS. 137 and 138) to a second retention position 3042 (shown in FIGS. 139 and 140).

[0323] In FIGS. 137 and 138, the tissue expander 3024 is in the first insertion position 3036, where FIG. 137 is a side view of an embodiment of the implant of the invention, and FIG. 138 is a top-down view of an embodiment of the implant 3100 of the invention, in the same first insertion position 3036 as the implant 3100 depicted in FIG. 137. The first end 3026 of the tissue expander 3024 is wedge-shaped in the direction of insertion, where the implant 3100 is inserted laterally. That is, where the implant 3100 is to be inserted laterally, the wedge-shaped first end 3026 is narrowest at the point of insertion and broadens along the length of the tissue expander 3024 toward the second end 3028 of the tissue expander 3024 that is located adjacent to the second end 3020 of the spacer 3016. The wedge shape of the tissue expander 3024 facilitates insertion of the implant 3100 by initiating distraction, if no other method is used during implantation, or by adding to or maintaining distraction created by another source, if any other such source is employed.

[0324] FIG. 138 shows a top-down view of the implant 3100, with the tissue expander 3024 in the first insertion position 3036. The elongated base element 3032 of the tissue expander 3024 in the first insertion position 3036, where insertion is from a lateral direction, is oriented in an anterior-posterior direction relative to a patient. In contrast, as discussed in greater detail below, the elongated base element 3032 of the tissue expander 3024 in the second retention position 3042 is oriented substantially perpendicular to the first insertion position 3036, in a direction that is substantially perpendicular to the anterior-posterior direction relative to the patient. In this embodiment, the elongated base element 3032 in the first insertion position 3036 can further be described as substantially perpendicular to the orientation of the first wing 3022, the first wing 3022 being at about a 90° angle from the anterior-posterior direction relative to the patient, substantially parallel to the axial plane of the patient.

[0325] FIG. 139 depicts a side view of the implant 3100 with the tissue expander 3024 rotated to the second retention position 3042. The tissue expander 3024 in the second retention position 3042 can prevent displacement of the implant 3100 after insertion in the spine of a patient. The tissue expander 3024, including the wedge-shaped first end 3026, and the elongated element 3032, can rotate from the first insertion position 3036 (FIG. 137) adapted to facilitate insertion, to the second retention position 3042 (FIG. 139) after insertion and positioning of the implant 3100.

[0326] In one embodiment, the tissue expander 3024 rotates about 90° to be reconfigured into the second retention position 3042, which alters the orientation of the wedge-shaped first end 3026 of the tissue expander 3024 and the elongated base element 3032. In the second retention position 3042, the tissue expander 3024 is rotated about 90° so that the elongated element 3032 (FIG. 139) is substantially perpendicular to the anterior-to-posterior direction of a patient. In other words, instead of being oriented with the axis 3038 of the elongated element 3032 from anterior to posterior (FIGS. 137 (side view) and 138 (top-down view)), the elongated base element 3032 is rotated about the elongated axis 3034 of the spacer 3016, so that the elongated base element 3032 is oriented generally parallel to the first wing 3022 (FIG. 139). It will be understood by those of ordinary skill in the art that the shift need not be 90° and could be by way of example of 45° or 60°.

[0327] FIG. 140 depicts the embodiment of the implant 3100, positioned between adjacent spinous processes, upon initial insertion and in the configuration of FIGS. 137 and 138.

[0328] The tissue expander 3024 can be locked into the second retention position 3042, as depicted in FIGS. 137-139. In this embodiment, the shaft 3017 has a bore 3046 extending completely therethrough, which bore 3046 has the same longitudinal axis 3034 as does shaft 3017. Positioned in bore 3046 is a shaft 3048 which can rotate in bore 3046, and which is connected to tissue expander 3024. Shaft 3048 includes a head 3050 which has a slot 3052 that can accept a rotation tool, such as a screwdriver. Rotation of the shaft 3048 causes the tissue expander 3024 to rotate. Thus once the implant 3100 is positioned between spinous processes, a screwdriver can be used to rotate the tissue expander 3024 from the insertion position as seen in FIGS. 137 and 138 to the retention position shown in FIG. 139. In a preferred embodiment the shaft 48 can rotate the tissue expander 3024 about 90°. Alternatively, different amounts of rotation can be accomplished. Although the patient's tissue will hold the tissue expander 3024 in the rotated position, if desired, a mechanism can be included to fix the shaft 3048 in the rotated position. Such mechanism can include a detent extending from head 3050 which can lock into a recess in the first wing 3022 as the shaft 3048 is rotated. Another mechanism can include ridges extending from the head 3050 of the shaft 3048 which can lock into recesses in the first wing 3022. One of ordinary skill in the art can appreciate that other lock-and-key mechanisms, or other mechanism that allows rotation and locking into the desired second retention position 3042, can also be employed to secure the second retention position 3042 for implant 3100.

[0329] FIGS. 141 and 142 depict an alternative embodiment of the implant 3200 of the disclosed invention. In this embodiment, both the first wing 3222 and the tissue expander 3224, are secured to shaft 3248 and can rotate together, from a first insertion position 3236 (FIG. 141) to a second retention position 3242, (FIG. 142) once the implant 3200 is positioned between the adjacent spinous processes. In the first insertion position 3236, the first wing 3222 and an elongated base element 3232 of the tissue expander 3224 are oriented for ease of insertion in an anterior-to-posterior direction of the patient. In the second retention position 3242, for second wing 3226 (FIG. 142) the elongated base element 3232 of the tissue expander 3224 and the first wing

3222 are oriented about 90° from the first insertion position 3236, or in other words, substantially perpendicular to the anterior-to-posterior direction of the first insertion position 3236.

[0330] The implant 3200 has a tissue expander 3224 having a wedge-shaped distal end 3226 and a proximal end 3228 that is located adjacent to rotatable spacer 3216 at a second distal end 3220 of a rotatable spacer 3216. A first wing 3222 is located adjacent to a proximal first end 3218 of spacer 3216. Focusing first on the tissue expander 3224, the wedge-shaped distal end 3226 is oriented in the first insertion position 236 to accommodate insertion between spinous processes 3212, 3214, with the flat distal part of the wedge 3226 oriented in an anterior-to-posterior direction in a patient. Also in the first insertion position 3236, the elongated base element 3232 of the tissue expander 3224, located adjacent to the spacer 3216, is oriented so that it is elongated in a direction that is anterior-to-posterior when the implant 3200 is implanted laterally in a patient.

[0331] With respect to the first wing 3222, when the tissue expander 3224 is oriented in the first insertion position 3236, the first wing 3222 is oriented, like the tissue expander 3224, in an anterior-to-posterior direction relative to a patient. As with the tissue expander 3226 rotation of the shaft 3248 causes the first wing 3222 to rotate so that is about perpendicular to an anterior-posterior direction.

[0332] In this embodiment, as indicated above, the first wing 3222 and the tissue expander 3224 are joined together by the shaft 3248 which has a longitudinal axis 3234. The spacer 3216 can rotate upon shaft 3248. Shaft 3248 includes a head 3250 which has a slot 3252 that can accept a rotation tool such as a screwdriver. Rotation of the shaft 3248 causes the first wing 3222 as well as the tissue expander 3224 to rotate. Thus, once the implant 3200 is positioned between spinous processes, a screwdriver can be used to rotate the tissue expander 3224 and the first wing 3222 from the insertion position 3236 as seen in FIG. 141 to the retention position 3242 shown in FIG. 142. In a preferred embodiment, the shaft 3248 can rotate the first wing 3222 as well as the tissue expander 3224 about 90°. Alternatively, different amounts of rotation can be accomplished.

[0333] Although the patient's tissue will hold the first wing 3222 and the tissue expander 3224 in the rotated position, if desired, a mechanism can be included to fix the shaft 3248 in the rotated position. Such mechanism can include a detent extending from the shaft 3248 which can lock into a recess in the spacer 3216. Accordingly, in the second retention position 3242, both the first wing 3222 and the tissue expander 3224 are rotated about 90° and can be locked into place.

[0334] FIGS. 143 and 144 depict yet another embodiment 3300 of the implant of the invention. In this embodiment 3300, the tissue expander 3324 has a first insertion position 3336 (FIG. 143 being a view looking down on the spinal column), and a second retention position 3342 (FIG. 3144 being a view looking from posterior to anterior into the spinal column). The tissue expander 3324 converts between the first insertion position 3336 and the second retention 3342 position through a pivoting motion, that may also include a rotation motion.

[0335] In this embodiment 3300, the first wing 3322 is positioned adjacent to a spacer 3316 at a first end 3318 of the

spacer. As above with the implants 3100 and 3200, the spacer 3316 is rotatably mounted over a hollow spacer-mounting shaft 3317 extending from the first wing 3322. The spacer 3316 can be cylindrical, or it can have other shapes, including but not limited to elliptical or tear-drop shape in cross-section.

[0336] The tissue expander 3324 of implant 3300 comprises an upper segment 3380 that is pivotally connected via a pivoting joint 3382, or other pivoting means, with a lower segment 3384. That is, a second end 3381 of the upper segment 3380 meets a second end 3383 of the lower segment 3384 via the pivoting joint 3382. A coiled spring 3321 is provided around pivoting joint 3382 and biases both the upper segment 3380 and the lower segment 3384 of the tissue expander 3324 against the spacer 3316. The pivoting joint 3382 is connected with a first end 3388 of a rod 3386. Rod 3386 is slidably disposed in a bore 3319 which runs the entire length of the spacer 316, and is located within hollow spacer-mounting shaft 3317.

[0337] The pivoting joint 3382 and the rod 3386 provide the mechanism whereby the tissue expander 3324 is converted from the first insertion position 3336 to the second retention position 3342. In the first insertion position 3336, depicted in FIG. 143, the first end 3388 of the rod 3386 extends outside the spacer 3316. The pivoting joint 3382, functionally connected with the first end 3388 of the rod 3386, is not in contact with the second end 3320 of the spacer 3316, but instead is separated by a segment of the rod 3386 from the second end 3320 of the spacer 3316. The upper segment 3380 of the tissue expander 3324 and the lower segment 3384 of the tissue expander 3324 meet at the pivoting joint 3382 to form a wedge-shaped first end 3326 of the tissue expander 3324 that is not in contact with the second end 3320 of the spacer 3316 when the tissue expander 3324 is in the first insertion position 3336. In one embodiment, wedge-shaped first end 3326 of the tissue expander 3324 can be wedge-shaped in the lateral direction of insertion, i.e., perpendicular to an anterior-to-posterior direction of a patient. The wedge-shaped first end 3326 is useful for inserting the implant 3300 between adjacent spinous processes.

[0338] Rod 3386 includes a head 3350 at the end of the rod 3386 distal from the tissue expander 3324. The head 3350 has a slot 3352 that can accept a tool adapted to be used to rotate and pull the rod 3386 through a bore 3319 of shaft 3317 toward the first wing, causing the upper segment 3380 and lower segment 3384 of the tissue expander 3324 to become aligned, such that the tissue expander 3324 is no longer wedge-shaped in the first insertion position 3336 (FIG. 143). Instead, the tissue expander 3324 adopts the form of a second wing (FIG. 144). In this embodiment, the tissue expander 3324 is wedge-shaped in the direction of lateral insertion in the first insertion position 3336, and the tissue expander in the second retention position is oriented substantially vertical, or substantially perpendicular to the anterior-to-posterior direction of the patient.

[0339] In contrast, in another embodiment, the tissue expander 3324 in the first insertion position 3336 is not wedge-shaped in a top view during lateral insertion, as discussed above. Instead, the wedge-shape of the tissue expander 3324 in the first insertion position 3336 is wedge-shaped looking into the spine from a posterior to anterior

direction. As such, merely pulling without rotating rod 3386 causes upper segment 3380 of the tissue expander 3324 and the lower segment 3384 of the tissue expander 3324 to pivot about the pivoting joint 3382, as above. Thus without rotating the tissue expander 3324, the tissue expander 3324 after reconfiguration will be oriented as depicted in FIG. 144.

[0340] FIG. 145 depicts the embodiment of FIGS. 143 and 144 deployed between spinous processes from a top view.

[0341] A rotating tool, such as a hook mounted on the end of a rod, can be used to pull the rod 3386 through the bore 3319, and can be used to rotate the tissue expander 3324 so that it is generally parallel to the first wing 3322. In a preferred embodiment, the rod 3386 can rotate the tissue expander about 90°. Alternatively, different amounts of rotation can be accomplished as needed to adapt to the anatomical structure of a patient.

[0342] Although the patient's tissue will hold the tissue expander 3324 in the rotated position 3342, if desired, a mechanism can be included to fix the rod 3386 in the rotated position. Such mechanism can include a detent extending from head 3350 which can lock into a recess in the first wing 3322 as the rod 3386 is pulled toward the first wing 3322 and rotated when the head 3350 is adjacent to the first wing 3322. Another mechanism can include ridges extending from the head 3350 of the rod 3386 which can lock into recesses in the first wing 3322.

[0343] One of ordinary skill in the art will appreciate that the locking components need not be limited to a detent and recess. The invention contemplates any locking mechanism that can secure the implant 3300 in a second retention position 3342 with the tissue expander 3324 reconfigured to a second wing.

[0344] FIG. 146 depicts a method 3400 of insertion of an embodiment of the invention from a lateral or postero-lateral approach. Using the disclosed method, any of implants 3100, 3200, and 3300 can be implanted.

[0345] First, an implant as in, by way of example only, embodiment 3100, is provided 3420, and the spine is accessed 3430. Access can be accomplished laterally or postero-laterally. The implant with the tissue expander 3034 in the first insertion position 3036 then is inserted 3440 between the spinous processes, either from the right lateral side, or the left lateral side.

[0346] The tissue expander 3024 is wedge-shaped in the first insertion position 3036, as described above, and is used to distract the vertebrae somewhat to facilitate the lateral insertion of the spacer 3016 between the adjacent spinous processes. This level of distraction may suffice to fully insert the implant 3100. However, if additional distraction is necessary prior to insertion of the tissue expander, distraction can be added prior to insertion 3435, by methods already well-known in the art.

[0347] Once the implant 3100 is positioned 3450 with the spacer maintaining distraction of the adjacent spinous processes, the tissue expander 3024 is moved from the first insertion position to the second retention position 3460. For implant 2100, moving the tissue expander 3024 involves rotating 3470 the tissue expander 3024 to the second retention position 3042. The rotation in one embodiment is

preferably about 90°. However, varying degrees of rotation are also possible. The tissue expander 3024 locks into the second retention position 3042, as described above. The base element 3032 in the second retention position 3042 is parallel to the first wing 3022, which also serves to retain the implant 2100 in position and prevent displacement.

[0348] For an implant as in embodiment 3200, both the first wing 3222 and the tissue expander 3224 are rotated together 3470, because in embodiment 3200, the spacer 3216 is connected with the first wing 3222.

[0349] For an implant as in embodiment 3300, the tissue expander 3324 is moved 3460 from a wedge-shaped first insertion position 3336 to a retaining arm or second wing second retention position 3342.

[0350] After the converting step 3460 the incision is closed 3470.

[0351] FIGS. 147 and 148 illustrate an implant 4100 in accordance with an embodiment of the present invention. The implant 4100 comprises a wing 4130, a spacer 4120, and a lead-in tissue expander (also referred to herein as a distraction guide) 4110. The distraction guide 4110 in this particular embodiment is wedge-shaped, i.e., the implant has an expanding cross-section from a distal end of the implant 4102 to a region 4104 where the guide 4110 joins with the spacer 4120 (referencing for the figures is based on the point of insertion of the implant between spinous processes). As such, the distraction guide functions to initiate distraction of the soft tissue and the spinous processes when the implant 4100 is surgically inserted between the spinous processes. It is to be understood that the distraction guide 4110 can be pointed and the like, in order to facilitate insertion of the implant 4100 between the spinous processes of adjacent cervical vertebrae. It is advantageous that the insertion technique disturb as little of the bone and surrounding tissue or ligaments as possible in order to reduce trauma to the site and promote early healing, and prevent destabilization of the normal anatomy. In the embodiment of FIGS. 147 and 148, there is no requirement to remove any of the bone of the spinous processes and no requirement to sever or remove from the body ligaments and tissues immediately associated with the spinous processes. For example, it is unnecessary to sever the ligamentum nuchae (supraspinous ligament), which partially cushions the spinous processes of the upper cervical vertebrae.

[0352] As can be seen in FIGS. 147-148, the spacer 4120 can be teardrop-shaped in cross-section perpendicular to a longitudinal axis 4125 of the implant 4100. In this way, the shape of the spacer 4120 can roughly conform to a wedge-shaped space, or a portion of the space, between adjacent spinous processes within which the implant 4100 is to be positioned. In other embodiments, the spacer 4120, can have alternative shapes such as circular, wedge, elliptical, ovoid, football-shaped, and rectangular-shaped with rounded corners and other shapes, and be within the spirit and scope of the invention. The shape of the spacer 4120 can be selected for a particular patient so that the physician can position the implant 4100 as close as possible to the anterior portion of the surface of the spinous process. The shape selected for the spacer 4120 can affect the contact surface area of the implant 4100 and the spinous processes that are to be subject to distraction. Increasing the contact surface area between the

implant 4100 and the spinous processes can distribute the force and load between the spinous frame and the implant 4100.

[0353] As can be seen in FIGS. 147 and 148, the wing 4130 in an embodiment can be elliptically shaped in cross-section perpendicular to the longitudinal axis 4125. The dimensions of the wing 4130 can be larger than that of the spacer 4120, particularly along the axis of the spine, and can limit or block lateral displacement of the implant 4100 in the direction of insertion along the longitudinal axis 4125. As illustrated in the embodiment of FIG. 149, the wing 4130 can alternatively have other cross-sectional shapes, such as teardrop, wedge, circular, ovoid, football-shaped, and rectangular-shaped with rounded corners and other shapes, and be within the spirit and scope of the invention. The wing 4130 has an anterior portion 4138 and a posterior portion 4136.

[0354] In other embodiments, the implant 4100 can include two wings, with a second wing 4160 (shown in FIG. 150) separate from the distraction guide 4110, spacer 4120 and first wing 4130. The second wing 4160 can be connected to the distal end of the spacer 4120. The second wing 4160, similar to the first wing 4130, can limit or block lateral displacement of the implant 4100, however displacement is limited or blocked in the direction along the longitudinal axis 4125 opposite insertion. When both the first wing 4130 and the second wing 4160 are connected with the implant 4100 and the implant 4100 is positioned between adjacent spinous processes, a portion of the spinous processes can be sandwiched between the first wing 4130 and the second wing 4160, limiting any displacement along the longitudinal axis 4125.

[0355] As can be seen in FIG. 150, the second wing 4160 can be teardrop-shaped in cross-section. The wider end 4166 of the second wing 4160 is the posterior end and the narrower end 4168 of the second wing 4160 is the anterior end. Unlike the first wing 4130, however, an opening 4164 is defined within the second wing 4160, the opening 4164 being at least partially circumscribed by a lip 4162 that allows the second wing 4160 to pass over the distraction guide 4110 to meet and connect with the spacer 4120. The second wing 4160 can be secured to the spacer 4120 once the second wing 4160 is properly positioned. The second wing 4160 can be connected with the implant after the implant 4100 is positioned between the spinous processes.

[0356] It is to be understood that the implant can be made in two pieces. The first piece can include the first wing 4130, the spacer 4120, and the distraction guide 4110. The second piece can include the second wing 4160. Each piece can be manufactured using technique known in the art (e.g., machining, molding, extrusion). Each piece, as will be more fully discussed below, can be made of a material that is bio-compatible with the body of the patient. An implant can be formed with multiple pieces and with the pieces appropriately joined together, or alternatively, an implant can be formed as one piece or joined together as one piece.

[0357] Further embodiments of implants in accordance with the present invention are depicted in FIGS. 151-153. In such embodiments, the spacer 4220 can be rotatable about the longitudinal axis 4225 relative to the first wing 4130, or relative to the first wing 4130 and a second wing 4160 where two wings are used. The spacer 4220 can be rotatable or

fixed relative to the distraction guide **4110**. Where the spacer **4220** is rotatable relative to the distraction guide **4110**, the spacer **4220** can include a bore **4222** running the length of the longitudinal axis **4225**, and a shaft **4224** inserted through the bore **4222** and connecting the distraction guide **4110** with the first wing **4130**. It can be advantageous to position any of the implants taught herein as close as possible to the vertebral bodies. The rotatable spacer **4220** can rotate to conform to or settle between adjacent spinous processes as the implant **200** is inserted and positioned during implantation, so that on average the contact surface area between the spacer **4220** and the spinous processes can be increased over the contact surface area between a fixed spacer **4120** and the spinous processes. Thus, the rotatable spacer **4220** can improve the positioning of the spacer **4220** independent of the wings **4130**, **4160** relative to the spinous processes. The embodiment of FIG. 6 includes a teardrop-shaped first wing **4130**, and a teardrop-shaped second wing **4160**, similar to the second wing **4160** depicted in the embodiment of FIG. 149. As discussed below, the shape of the wings **4130**, **4160** in FIGS. 149 and 152 is such that the implants **4100**, **4200** accommodate the twisting of the cervical spine along its axis, for example, as the head of a patient turns from side-to-side.

[0358] FIG. 154 is a perspective view and FIG. 155A is an end view of still another embodiment of an implant in accordance with the present invention, wherein the posterior portion **4336** of the teardrop-shaped first wing **4330** is truncated, making the first wing **4330** more ovoid in shape. In this configuration, the anterior portion **4138** of the first wing **4330** can be longer than the truncated posterior end **4336** of the first wing **4330**. As in previous embodiments, the spacer **4120** can alternatively be a rotatable spacer rather than a fixed spacer. FIG. 155B illustrates a second wing **4360** for use with such implants **4300**, the second wing **4360** having a truncated posterior end **4366**. Truncation of the posterior ends **4336**, **4366** of the first and second wings **4330**, **4360** can reduce the possibility of interference of implants **4300** having such first and second wings **4330**, **4360** positioned between spinous processes of adjacent pairs of cervical vertebrae, e.g., implants between cervical vertebrae five and six, and between cervical vertebrae six and seven. During rotation of the neck, the spinous process move past each other in a scissor-like motion. Each cervical vertebra can rotate relative to the next adjacent cervical vertebra in the general range of about 60°-12°. In addition, about 50 percent of the rotational movement of the neck is accomplished by the top two neck vertebrae. Thus, such embodiments can accommodate neck rotation without adjacent embodiments interfering with each other.

[0359] With respect to the prior embodiments which have first and second wings **4130**, **4160**, the second wing **4160**, can be designed to be interference-fit onto the spacer **4120** (where the spacer is fixed) or a portion of the distraction guide **4110** adjacent to the spacer **4120** (where the spacer is rotatable). Where the second wing **4160** is interference-fit, there is no additional attachment device to fasten the second wing **4160** relative to the remainder of the implant. Alternatively, various fasteners can be used to secure the second wing relative to the remainder of the implant. For example, FIGS. 156-158 illustrate an embodiment of an implant **4400** including a teardrop-shaped second wing **4460** having a bore **4463** through a tongue **4461** at the posterior end of the second wing **4460**. The bore **4463** is brought into alignment

with a corresponding bore **4440** on the spacer **4120** when the second wing **4460** is brought into position by surgical insertion relative to the rest of the implant **4400**. A threaded screw **4442** can be inserted through the aligned bores **4463**, **4440** in a posterior-anterior direction to secure the second wing **4460** to the spacer **4120**. The direction of insertion from a posterior to an anterior direction has the screw **4442** engaging the bores **4463**, **4440** and the rest of the implant **4400** along a direction that is generally perpendicular to the longitudinal axis **4125**. This orientation is most convenient when the surgeon is required to use a screw **4442** to secure the second wing **4460** to the rest of the implant **4400**. Other securing mechanisms using a member inserted into corresponding bores **4463**, **4440** on the spacer **4120** and second wing **4460** are within the spirit of the invention. It should be understood that a rotatable spacer **4220** also can be accommodated by this embodiment. With a rotatable spacer **4220**, the second wing **4460** would be attached to a portion of the distraction guide **4110** that is located adjacent to the rotatable spacer **4220**.

[0360] FIGS. 159A-159B depict a further embodiment **4500** wherein the second wing **4560** is secured to the spacer **4120** by a mechanism including a flexible hinge **4565**, with a protrusion **4561** on the end of the hinge **4565** adjacent to the lip **4562** of the opening **4564** defined by portions of the second wing **4560**. The securing mechanism also encompasses an indentation **4540** on the spacer **4120**, wherein the indentation **4540** accommodates the protrusion **4561** on the end of the flexible hinge **4565**. During surgery, after insertion of the distraction guide **4110**, spacer **4120**, and first wing **4130**, the second wing **4560** is received over the distraction guide **4110** and the spacer **4120**. As the second wing **4560** is received by the spacer **4120**, the flexible hinge **4565** and its protrusion **4561** deflect until the protrusion **4561** meets and joins with the indentation **4540** in the spacer **4120**, securing the second wing **4560** to the spacer **4120**. Again in embodiments where the spacer can rotate, the indentation **4540** is located on an end of the distraction guide **4110** that is adjacent to the rotatable spacer **4220**. With respect to the flexible hinge **4565**, this hinge is in a preferred embodiment formed with the second wing **4560** and designed in such a way that it can flex as the hinge **4565** is urged over the distraction guide **4110** and the spacer **4120** and then allow the protrusion **4561** to be deposited into the indentation **4540**. Alternatively, it can be appreciated that the indentation **4540** can exist in the second wing **4560** and the flexible hinge **4565** and the protrusion **4561** can exist on the spacer **4120** in order to mate the second wing **4560** to the spacer **4120**. Still alternatively, the flexible hinge **4565** can be replaced with a flexible protrusion that can be flexed into engagement with the indentation **4540** in the embodiment with the indentation **4540** in the spacer **4120** or in the embodiment with the indentation **4540** in the second wing **4560**. One of ordinary skill in the art will appreciate the myriad different ways with which the second wing can be mated with the implant.

[0361] FIGS. 161A-162 illustrate an embodiment of an implant **4600** wherein anterior ends of a first wing and second wing **4660** flare out at an angle away from the spacer **4120** and away from each other. The cervical spinous processes are themselves wedge-shaped when seen from a top view. The first wing **4630** and second wing **4660** flare out so that the implant **4600** can roughly conform with the wedge shape of the spinous processes, allowing the implant

4600 to be positioned as close as possible to the vertebral bodies of the spine where the load of the spine is carried. The first and second wings **4630**, **4660** are positioned relative to the spacer, whether the spacer is fixed **4120** or rotatable **4220**, so that the wings flare out as the wings approach the vertebral body of the spine. FIG. **161B** is a top view of the implant **4600** of FIG. **161A** removed from proximity with the spinous processes. The first wing **4630** is aligned at an angle with respect to an axis along the spinous processes perpendicular to the longitudinal axis (also referred to herein as the plane of symmetry). In one embodiment, the angle is about 30° , however, the angle θ can range from about 15° to about 45° . In other embodiments, other angles outside of this range are contemplated and in accordance with the invention. Likewise, the second wing **4660** can be aligned along a similar, but oppositely varying range of angles relative to the plane of symmetry.

[0362] As described above in reference to FIG. **150**, the second wing **4660** defines an opening which is outlined by a lip. As is evident, the lip can be provided at an angle relative to the rest of the second wing **4660** so that when the lip is urged into contact with the spacer **4120**, the second wing **4660** has the desired angle relative to the spacer **4120**. As discussed above, there are various ways that the second wing **4660** is secured to the spacer **4120**. FIG. **161A** depicts a top view of one such implant **4600** placed between the spinous processes of adjacent cervical vertebrae. FIG. **162** is a top view illustrating two layers of distracting implants **4600** with flared wings **4630**, **4660**.

[0363] Systems and methods in accordance with the present invention can include devices that can be used in cooperation with implants of the present invention. FIG. **163** illustrates “stops” (also referred to herein as “keeps”) **4656**, which are rings of flexible biocompatible material, which can be positioned around the spinous processes of adjacent cervical vertebrae and located posteriorly to the implant **4600**. The keeps **4656** can prevent posterior displacement of implants. In one embodiment, the keeps can include a ring having a slit **4658**. The keeps **4656** can be somewhat sprung apart, so that the keep **4656** can be fit over the end of the spinous process and then allowed to spring back together in order to hold a position on the spinous process. The keep **4656** can act as a block to the spacer **4120** in order to prevent the implant **4600** from movement in a posterior direction.

[0364] Implants Having Deployable Wings

[0365] In other embodiments, implants in accordance with the present invention can comprise a “matchbox”-like structure having a first configuration (as shown in FIG. **164A**) and a second, deployed configuration (as shown in FIG. **164B**). Arranged in the first configuration, such implants **4700** can have a substantially flat profile having an approximately uniform thickness. The uniform thickness approximates the thickness of a spacer **4720** of the implant **4700**. The implant **4700** can comprise a distraction guide **4710** at a proximal end of the implant, the distraction guide **4710** having a slightly rounded or tapered shape to pierce and/or distract a space between adjacent spinous processes. The implant **4700** can further comprise a plurality of hinged structures **4750-4757**, the hinged structures **4750-4757** being collapsed so as to facilitate the substantially flat profile. The hinged structures **4750-4757** are pivotally connected with the spacer **4720** and extend from both sides of

the spacer **4720**. As shown in FIG. **164A**, a support structure **4722** extends from the spacer **4720** toward the distal end of the implant **4700**. A rod **4715** (or alternatively some other mechanism such as a tab) can be connected with the proximal end of the implant **4700** and can extend through the hinged structures **4750-4753**, through the spacer **4720**, and through the support structure **4722** so that the rod **4715** is accessible.

[0366] Referring to FIG. **164B**, once the implant **4700** is positioned as desired between adjacent spinous processes, the rod **4715** can be drawn in a direction opposite the direction of insertion along the longitudinal axis **4725** so that the hinged structures **4750-4757** fold outward to form a first wing **4730** and a second wing **4760** between which is arranged the spacer **4720** and a portion of the spinous processes. As the hinged structures **4750-4757** fold outward, the height of the first and second wings **4730**, **4760** increases from approximately the same as the thickness of the spacer **4720** to a height such that the first and second wing **4730**, **4760** can limit or block movement of the implant **4700** along the longitudinal axis **4725** when positioned between adjacent spinous processes. As can be seen, the second wing **4760** includes four hinged structures **4750-4753**: an upper first structure **4750** connected by a hinge to an upper second structure **4752**, and a lower first structure **4751** connected by a hinge to a lower second structure **4753**. The hinged structures **4750-4753** pivot outward to form an upper end **4762** of the second wing and a lower end **4764** of the second wing. Likewise, the first wing **4730** includes four hinged structures **4754-4757**: an upper first structure **4754** connected by a hinge to an upper second structure **4756**, and a lower first structure **4755** connected by a hinge to a lower second structure **4757**. However, unlike the second wing **4760**, the first wing **4730** is (effectively) bisected by the support structure **4722** so that the first wing **4730** comprises four winglets **4731-4734**. The hinged structures **4754-4757** pivot outward to form upper winglets **4731**, **4732** of the first wing and lower winglets **4733**, **4734** of the first wing.

[0367] As mentioned above, the support structure **4722** extends from the spacer **4720** toward the distal end of the implant **4700**. The spacer **4720** and the support structure **4722** include a bore or other cavity through which the rod **4715** can travel. Applying resistive force to the support structure **4722** can fix the spacer **4720** in place between spinous processes when drawing the rod **4715** through the bore. As the rod **4715** is drawn through the bore, the hinged structures **4752**, **4753** with which the proximal end of the rod **4715** is connected are drawn with the rod **4715**. As the rod **4715** is drawn through the spacer **4720**, the hinged structures **4752,4753** are drawn toward the spacer **4720**. The hinged structures **4750-4753** pivot outward to accommodate the relative movement between the rod **4715** and the spacer **4720**. Accordingly, the second wing **4760** has been satisfactorily deployed.

[0368] The hinged structures **4756**, **4757** of the first wing **4730** can cause deployment of the first wing **4730** by applying resistive force to the hinged structures **4756**, **4757** while drawing the spacer **4720** (via the support structure **4722**), or by urging the hinged structures **4756**, **4757** toward the spacer **4720**. The resistive force or urging can be applied by a second stop **4784** that can fit around the support structure **4722** and can be interference fit or otherwise selectively fixed with the support structure **4722**. As the

second stop **4784** is pushed along the longitudinal axis **4725**, along the support structure **4722**, the hinged structures **4754-4757** pivot outward to accommodate the relative movement between the second stop **4784** and the spacer **4720**. Accordingly, the first wing **4730** has been satisfactorily deployed.

[0369] FIGS. **165A** and **165B** are posterior views of the implant **4700** positioned between adjacent spinous processes **4002**, **4004** demonstrating an embodiment of a method for deploying the implant **4700** between the spinous processes **4002**, **4004**. The implant **4700** can be positioned so that a distraction guide **4710** of the implant **4700** is arranged at a space between the spinous processes **4002**, **4004**. The implant **4700** can then be urged between the spinous processes **4002**, **4004** so that the spacer **4720** is positioned as desired. The substantially flat profile of the implant **4700** can ease positioning of the spacer **4720** by reducing potential obstructing surfaces that can resist movement of the implant **4700** during implantation. The second wing **4760** and the first wing **4730** can then be deployed to limit movement of the implant **4700**. To deploy the second wing **4760** the rod **4715** is drawn in a direction opposite the direction of insertion along the longitudinal axis **4725**. The upper end **4762** and lower end **4764** of the second wing extend outward as described above. Once the second wing **4760** is deployed, the rod **4715** can be fixed in position relative to the spacer **4720**. This can be accomplished using myriad different mechanisms. For example, as shown a first stop **4782** can be interference fit to the rod **4715** and positioned against the support structure **4722** along the rod **4715**. The first stop **4782** can grip the rod **4715**, as with a friction fit between the first stop **4782** and the rod **4715**, so that the rod **4715** is prevented from moving through the bore of the support structure **4722** by interference between the first stop **4782** and the support structure **4722**. In other embodiments, some other mechanism can be used, such as a pin (e.g., a cotter pin), a latch system, etc. One of ordinary skill in the art will appreciate the myriad different mechanisms for fixing a rod **4715** in position relative to the spacer **4720**. The upper second structure **4756** and the lower second structure **4757** can be urged toward the spacer **4720** in the direction of insertion along the longitudinal axis **4725** using a second stop **4784** as described above, causing the upper winglets **4731**, **4732** and lower winglets **4733**, **4734** to extend outward to form the first wing **4730**. Once the first wing **4730** is deployed, the hinged structures **4754-4757** can be fixed in position using the second stop **4784** or some other mechanism. The second stop **4784** can grip the support structure **4722**, as with a friction fit or pin, and resist movement of the hinged structures **4754-4757**, thereby preventing collapse. As above, one of ordinary skill in the art will appreciate the myriad different mechanisms for fixing the first wing **4730** in a deployed position. With the first wing **4730** and the second wing **4760** deployed, movement of the implant **4700** along the longitudinal axis **4725** can be limited or blocked, thereby resisting undesirable displacement of the implant **4700**.

[0370] It should be noted that with implants as described above in reference to FIGS. **164A-167** the rod **4715** can optionally be trimmed or otherwise partially detached to decrease a space required to accommodate the implant **4700**, **4800** within the patient's spine. For example, the structure of the rod **4715** can be beveled or otherwise weakened near a distal end of the rod **4715** to allow the rod **4715** to be

snapped off when the first and second wings **4730**, **4760**, **4830**, **4860** are deployed and the rod **4715** is fixed in place. In other embodiments, a tool (not shown) can be used to cut the rod **4715** after the first and second wings **4730**, **4760**, **4830**, **4860** are deployed and the rod **4715** is fixed in place. Still further, the rod **4715** need not comprise a rigid structure, but rather alternatively can include a tether, string, or similarly flexible structure that can be placed in tension to retain the second wing **4760**, **4860** and/or first wing **4730**, **4830** in a deployed position.

[0371] Referring to FIGS. **166A** and **166B**, a still further embodiment of an implant **4800** in accordance with the present invention is shown. In such an embodiment, a flexible strap **4890** can be connected between pairs of hinged structures (i.e., **4850** and **4852**, **4851** and **4853**, **4854** and **4856**, **4855** and **4857**). The flexible strap **4890** can limit the relative movement of the hinged structures **4850-4857** so that first wing **4830** and second wing **4860** have increased rigidity when fully deployed. The implant **800** need not include the support structure **4722** of the previous embodiment. A resistive force can be applied to the hinged structures **4856**, **4857** so that as the rod **4715** is drawn in a direction opposite the direction of insertion along the longitudinal axis **4825** the resistive force causes the hinged structures **4854-4857** to extend outward to form the first wing **4830**. As the hinged structures **4854-4857** extend outward the flexible strap **4890** connected opposite the hinge unfolds. Once the hinged structures **4854-4857** reach a maximum extension, the flexible strap **4890** becomes taut and resists further extension, locking the first wing **4830** in place. The flexible straps **4890** can provide the first wing **4830** with sufficient rigidity to resist movement of the spacer **4720**, so that as the rod **4715** is further drawn the rod **4715** moves through the spacer **4720** and the hinged structures **4852**, **4853** connected with the rod **4715** are drawn toward the spacer **4720**. As the hinged structures **4852**, **4853** connected with the rod **4715** are drawn toward the spacer **4720**, all of the hinged structures **4850-4853** extend outward to deploy the second wing **4860**. The flexible strap **4890**, connected opposite the hinge, unfolds. Once the hinged structures **4854-4857** reach a maximum extension the flexible strap **4890** becomes taut and resists further extension, locking the first wing **4830** in place. A stop **4882** (or alternatively some other mechanism such as a pin) can be fixed to the rod **4715** to create interference between the stop **4882** and the hinged structures **4832**, **4834** of the first wing **4830** that resists movement of the rod **4715**.

[0372] The flexible straps **4890** can be made from a biocompatible material. In an embodiment, the flexible straps **4890** can be made from a braided polyester suture material. Braided polyester suture materials include, for example, Ethibond, Ethiflex, Mersilene, and Dacron, and are non-absorbable, having high tensile strength, low tissue reactivity and improved handling. In other embodiments, the flexible straps **4890** can be made from stainless steel (i.e., surgical steel), which can be woven into a strap, for example. In still other embodiments, flexible straps **4890** can be made from some other material (or combination of materials) having similar properties.

[0373] FIG. **167** is a posterior view of the implant **4800** positioned between adjacent spinous processes **4002**, **4004** demonstrating an embodiment of a method for deploying the implant **4800** between the spinous processes **4002**, **4004**.

The first wing **4830** can be deployed to limit movement of the implant **4800** relative to the spinous processes **4002**, **4004**. To deploy the first wing **4830** the rod **4715** can be held fixed in position or urged in a direction opposite the direction of insertion along the longitudinal axis **4825** while a force is applied to the hinged structures **4854-4857** (FIG. **166A**) of the first wing **4830** to cause the upper end **4832** of the first wing and the lower end **4834** of the first wing to extend away from the rod **4715**, thereby deploying the first wing **4830**. The rod **4715** can be further urged in the direction opposite the direction of insertion so that the proximal end of the rod **4715** pivotably connected with the hinged structures **4852**, **4853** that comprise the distraction guide **4710**, is drawn toward the spacer **4720**, causing the upper end **4862** of the spacer, and the lower end **864** of the spacer to extend away from the rod **4715**. Once the second wing **4860** and the first wing **4830** are deployed, the rod **4715** can be fixed in position relative to the spacer **4720**. As above, this can be accomplished using myriad different mechanisms. For example, as shown a first stop **4882** can be interference fit to the rod **4715** and positioned against the first wing **4830** along the rod **4715**. The first stop **4882** can grip the rod **4715** so that the rod **4715** is prevented from moving by a friction fit between the first stop **4882** and the rod **4715**. In other embodiments, some other mechanism can be used, such as a pin (e.g., a cotter pin), a latch system, etc. One of ordinary skill in the art will appreciate the myriad different mechanisms for fixing a rod **4715** in position relative to the spacer **4720**. With the first wing **4830** and the second wing **4860** deployed, movement of the implant **4800** along the longitudinal axis **4825** can be limited or blocked, thereby resisting undesirable displacement of the implant **4800**.

[0374] Referring to FIGS. **168A** and **168B**, in still other embodiments, implants in accordance with the present invention can comprise a “matchbox”-like structure having a rounded, collapsed first configuration and a second, deployed configuration. Arranged in the first configuration, such implants **4900** can have a shape allowing the implant **4900** to be more naturally inserted through a cannula. As shown, such a shape includes a substantially circular cross-section, though in other embodiments the implant can have an ovoid or elliptical cross-section, thereby allowing a spacer shape to be employed that generally accommodates a space between adjacent spinous processes. However, it will be appreciated that an implant **4900** having a circular cross-section can most efficiently use the space of a cannula, where the cannula includes a circular cross-section; therefore, it may be preferable to employ an implant **4900** having a circular cross-section where a physician desired to minimize the diameter of the cannula inserted into the surgical site.

[0375] The cross-section of the implant **4900** in a first configuration is generally consistent along the implant's length, having a diameter generally the thickness of a spacer **4920** of the implant **4900**. The implant **4900** can comprise a distraction guide **4910** at a proximal end of the implant **4900**, the distraction guide **4910** having a rounded (as shown) or tapered shape to pierce and/or distract a space between adjacent spinous processes. However, where a cannula is employed to deliver an implant to a surgical site, the implant **4900** can optionally include a distraction guide **4910** at the proximal end. The surgical site, and associated tissues and structures can be distracted and repositioned by the cannula, allowing substantially unobstructed access to

the surgical site by the implant **4900**. In such circumstance a distraction guide **4910** may not be necessary.

[0376] The implant **4900** can further comprise a plurality of hinged structures **4950-4957**, the hinged structures **4950-4957** being collapsed so as to facilitate the substantially collapsed profile. The hinged structures **4950-4957** are pivotally connected with the spacer **4920** and extend from both sides of the spacer **4920**. A rod **4915** (or alternatively some other mechanism such as a tab) can be connected with the proximal end of the implant **4900** and can extend through the hinged structures **4950-4953**, and through the spacer **4920** so that the rod **4915** is accessible to a physician.

[0377] Referring to FIGS. **168B** and **168C**, once the implant **4900** is positioned as desired between adjacent spinous processes, the rod **4915** can be drawn in a direction opposite the direction of insertion along the longitudinal axis **4925** so that the hinged structures **4950-4957** fold outward to form a first wing **4930** and a second wing **4960** between which is arranged the spacer **4920** and a portion of the spinous processes. As the hinged structures **4950-4957** fold outward, the height of the first and second wings **4930**, **4960** increases from approximately the same as the thickness of the spacer **4920** to a height such that the first and second wing **4930**, **4960** can limit or block movement of the implant **4900** along the longitudinal axis **4925** when positioned between adjacent spinous processes. As can be seen, the second wing **4960** includes four hinged structures **4950-4953**: an upper first structure **4950** connected by a hinge to an upper second structure **4952**, and a lower first structure **4951** connected by a hinge to a lower second structure **4953**. The hinged structures **4950-4953** pivot outward to form an upper end **4962** of the second wing and a lower end **4964** of the second wing. Likewise, the first wing **4930** includes four hinged structures **4954-4957**: an upper first structure **4954** connected by a hinge to an upper second structure **4956**, and a lower first structure **4955** connected by a hinge to a lower second structure **4957**.

[0378] Embodiments as described above in reference to FIGS. **164A** and **164B** included a support structure **4722** extending from the spacer **4720**. Likewise, a support structure can optionally extend from the spacer **4920** of the cannula delivered implant **4900**. However, such a structure need not be necessary where the first wing **4930** is prevented from deploying during deployment of the second wing **4960** by the cannula **995** itself (see FIG. **169B**). Referring to FIGS. **169A** and **169B**, once the cannula is positioned at the surgical site, the implant **4900** can be urged through the cannula so that the hinged structures **4950-4953** are clear of the cannula. The rod **4915** can then be urged in an opposite direction (relative to insertion) along the longitudinal axis **4925** to deploy the second wing **4960**. As the rod **4915** is drawn through the spacer **4920**, the hinged structures **4952**, **4953** are drawn toward the spacer **4920**. The hinged structures **4950-4953** pivot outward to accommodate the relative movement between the rod **4915** and the spacer **4920**. Accordingly, the second wing **4960** has been satisfactorily deployed.

[0379] Once the second wing **4960** is deployed, the cannula **995** can be retracted from the surgical site, thereby allowing the hinged structures **956**, **4957** of the first wing **4930** to deploy by urging the hinged structures **4956**, **4957** toward the spacer **4920**. The urging can be applied by a stop

4982 that can fit around the rod **4915** and can be interference fit or otherwise selectively fixed with the rod **4915**. As the stop **982** is pushed along the longitudinal axis **4925**, along the rod **4915**, the hinged structures **4954-4957** pivot outward to accommodate the relative movement between the stop **4982** and the spacer **4920**. Accordingly, the first wing **4930** has been satisfactorily deployed.

[**0380**] Once the second wing **4960** and the first wing **4930** are deployed, the rod **4915** can be fixed in position relative to the spacer **4920**. As above, this can be accomplished using myriad different mechanisms. For example, as shown a stop **4982** can be interference fit to the rod **4915** and positioned against the first wing **4930** along the rod **4915**. The stop **4982** can grip the rod **4915** so that the rod **4915** is prevented from moving by a friction fit between the stop **4982** and the rod **4915**. In other embodiments, some other mechanism can be used, such as a pin (e.g., a cotter pin), a latch system, etc. One of ordinary skill in the art will appreciate the myriad different mechanisms for fixing a rod **4915** in position relative to the spacer **4920**. With the first wing **4930** and the second wing **4960** deployed, movement of the implant **4900** along the longitudinal axis **4925** can be limited or blocked, thereby resisting undesirable displacement of the implant **4900**.

[**0381**] It should be noted that with implants as described above in reference to FIGS. **168A-169B** the rod **4915** can optionally be trimmed or otherwise partially detached to decrease a space required to accommodate the implant **4900** within the patient's spine. For example, the structure of the rod **4915** can be beveled or otherwise weakened near a distal end of the rod **4915** to allow the rod **4915** to be snapped off when the first and second wings **4930, 4960** are deployed and the rod **4915** is fixed in place. In other embodiments, a tool (not shown) can be used to cut the rod **4915** after the first and second wings **4930, 4960** are deployed and the rod **4915** is fixed in place. Still further, the rod **4915** need not comprise a rigid structure, but rather alternatively can include a tether, string, or similarly flexible structure that can be placed in tension to retain the second wing **4960** and/or first wing **4930** in a deployed position.

[**0382**] Referring to FIGS. **168B, 168C** and **169B**, the implant **4900** is shown having operably connected "hinged" structures **4950-4957**. Such structures can be hinged in any way that permits relative movement. For example, the structures may be hinged by way of flexible straps, for example as described above in reference to FIG. **167B**. Alternatively, the structures can be hinged using some other technique. For example, referring to FIG. **169C**, one or a pair of cords **4996** can connect pairs of hinged structures so that relative movement is restricted, thereby permitting hinging motion, while resisting separation of the structures. In still other embodiments, some other mechanism can be employed to define a range of movement of the hinged structures **4950-4957**. One of ordinary skill in the art will appreciate the myriad different techniques for defining a range of motion of two mechanical parts.

[**0383**] As with the flexible straps **4890** above, the cord **4996** can be made from a biocompatible material. In an embodiment, the cord **4996** can be made from a braided polyester suture material. Braided polyester suture materials include, for example, Ethibond, Ethiflex, Mersilene, and Dacron, and are non-absorbable, having high tensile strength, low tissue reactivity and improved handling. In other embodiments, the cords **4996** can be made from stainless steel (i.e., surgical steel), which can be woven into

a strap, for example. In still other embodiments, the cords **4996** can be made from some other material (or combination of materials) having similar properties.

[**0384**] Materials for Use in Implants of the Present Invention

[**0385**] In some embodiments, the implant can be fabricated from medical grade metals such as titanium, stainless steel, cobalt chrome, and alloys thereof, or other suitable implant material having similar high strength and biocompatible properties. Additionally, the implant can be at least partially fabricated from a shape memory metal, for example Nitinol, which is a combination of titanium and nickel. Such materials are typically radiopaque, and appear during x-ray imaging, and other types of imaging. Implants in accordance with the present invention, and/or portions thereof can also be fabricated from somewhat flexible and/or deflectable material. In these embodiments, the implant and/or portions thereof can be fabricated in whole or in part from medical grade biocompatible polymers, copolymers, blends, and composites of polymers. A copolymer is a polymer derived from more than one species of monomer. A polymer composite is a heterogeneous combination of two or more materials, wherein the constituents are not miscible, and therefore exhibit an interface between one another. A polymer blend is a macroscopically homogeneous mixture of two or more different species of polymer. Many polymers, copolymers, blends, and composites of polymers are radiolucent and do not appear during x-ray or other types of imaging. Implants comprising such materials can provide a physician with a less obstructed view of the spine under imaging, than with an implant comprising radiopaque materials entirely. However, the implant need not comprise any radiolucent materials.

[**0386**] One group of biocompatible polymers are the polyaryl ester ketones which has several members including polyetheretherketone (PEEK), and polyetherketoneketone (PEKK). PEEK is proven as a durable material for implants, and meets the criterion of biocompatibility. Medical grade PEEK is available from Victrex Corporation of Lancashire, Great Britain under the product name PEEK-OPTIMA. Medical grade PEKK is available from Oxford Performance Materials under the name OXPEKK, and also from CoorsTek under the name BioPEKK. These medical grade materials are also available as reinforced polymer resins, such reinforced resins displaying even greater material strength. In an embodiment, the implant can be fabricated from PEEK 450G, which is an unfilled PEEK approved for medical implantation available from Victrex. Other sources of this material include Gharda located in Panoli, India. PEEK 450G has the following approximate properties: TABLE-US-00001 Property Value Density 1.3 g/cc Rockwell M 99 Rockwell R 126 Tensile Strength 97 MPa Modulus of Elasticity 3.5 GPa Flexural Modulus 4.1 GPa

[**0387**] PEEK 450G has appropriate physical and mechanical properties and is suitable for carrying and spreading a physical load between the adjacent spinous processes. The implant and/or portions thereof can be formed by extrusion, injection, compression molding and/or machining techniques.

[**0388**] It should be noted that the material selected can also be filled. Fillers can be added to a polymer, copolymer, polymer blend, or polymer composite to reinforce a polymeric material. Fillers are added to modify properties such as mechanical, optical, and thermal properties. For example, carbon fibers can be added to reinforce polymers mechani-

cally to enhance strength for certain uses, such as for load bearing devices. In some embodiments, other grades of PEEK are available and contemplated for use in implants in accordance with the present invention, such as 30% glass-filled or 30% carbon-filled grades, provided such materials are cleared for use in implantable devices by the FDA, or other regulatory body. Glass-filled PEEK reduces the expansion rate and increases the flexural modulus of PEEK relative to unfilled PEEK. The resulting product is known to be ideal for improved strength, stiffness, or stability. Carbon-filled PEEK is known to have enhanced compressive strength and stiffness, and a lower expansion rate relative to unfilled PEEK. Carbon-filled PEEK also offers wear resistance and load carrying capability.

[0389] As will be appreciated, other suitable similarly biocompatible thermoplastic or thermoplastic polycondensate materials that resist fatigue, have good memory, are flexible, and/or deflectable, have very low moisture absorption, and good wear and/or abrasion resistance, can be used without departing from the scope of the invention. As mentioned, the implant can be comprised of polyetherketoneketone (PEKK). Other material that can be used include polyetherketone (PEK), polyetherketoneetherketoneketone (PEKEKK), polyetheretherketoneketone (PEEKK), and generally a polyaryletheretherketone. Further, other polyketones can be used as well as other thermoplastics. Reference to appropriate polymers that can be used in the implant can be made to the following documents, all of which are incorporated herein by reference. These documents include: PCT Publication WO 02/02158 A1, dated Jan. 10, 2002, entitled "Bio-Compatible Polymeric Materials;" PCT Publication WO 02/00275 A1, dated Jan. 3, 2002, entitled "Bio-Compatible Polymeric Materials;" and, PCT Publication WO 02/00270 A1, dated Jan. 3, 2002, entitled "Bio-Compatible Polymeric Materials." Other materials such as Bionate®, polycarbonate urethane, available from the Polymer Technology Group, Berkeley, Calif., may also be appropriate because of the good oxidative stability, biocompatibility, mechanical strength and abrasion resistance. Other thermoplastic materials and other high molecular weight polymers can be used.

[0390] As described above, the binder can be made from a biocompatible material. In an embodiment, the binder can be made from a braided polyester suture material. Braided polyester suture materials include, for example, Ethibond, Ethiflex, Mersilene, and Dacron, and are nonabsorbable, having high tensile strength, low tissue reactivity and improved handling. In other embodiments, the binder can be made from stainless steel (i.e., surgical steel), which can be braided into a tether or woven into a strap, for example. In still other embodiments, the binder can be made from some other material (or combination of materials) having similar properties.

[0391] It is to be understood that embodiments in accordance with the present invention can be constructed without a pliant material. It is also to be understood that the embodiments in accordance with the present invention can have other dimensions

[0392] Methods for Implanting Interspinous Implants

[0393] A minimally invasive surgical method for implanting an implant 4400 in the cervical spine is disclosed and taught herein. In this method, as shown in FIG. 170, preferably a guide wire 4080 is inserted through a placement network or guide 90 into the neck of the implant recipient. The guide wire 4080 is used to locate where the implant is

to be placed relative to the cervical spine, including the spinous processes. Once the guide wire 4080 is positioned with the aid of imaging techniques, an incision is made on the side of the neck so that an implant in accordance with an embodiment of the present invention, can be positioned in the neck through an incision and along a line that is about perpendicular to the guide wire 4080 and directed at the end of the guide wire 4080. In one embodiment, the implant can be a sized implant 4400 (i.e., having a body that is not distractible), such as described above in FIGS. 147-163 and including a distraction guide 4110, a spacer 4120, and a first wing 4130. The implant 4400 is inserted into the neck of the patient. Preferably during insertion, the distraction guide 4110 pierces or separates the tissue without severing the tissue.

[0394] Once the implant 4400 is satisfactorily positioned, a second wing 4460 can be optionally inserted along a line that is generally co-linear with the line over which the implant 4400 is inserted but from the opposite side of the neck. The anatomy of the neck is such that it is most convenient and minimally invasive to enter the neck from the side with respect to the implant 4400 and the second wing 4460. The second wing 4460 is mated to the implant and in this particular embodiment, the second wing 4460 is attached to the implant 4400 by the use of a fastener, for example by a screw 4442. Where a screw is used, the screw 4442 can be positioned using a screw driving mechanism that is directed along a posterior to anterior line somewhat parallel to the guide wire 4080. This posterior to anterior line aids the physician in viewing and securing the second wing 4460 to the implant. The second wing 4460 is positioned so that a bore 4463 formed in a lip 4461 of the second wing 4460 is aligned with a bore 4440 of the implant 4400, as described above. The screw 4442 is positioned within both bores and secured, at least, to the bore 4440 of the implant 4400. In other embodiments, the second wing can be interference fit with the implant, as described above, or fastened using some other mechanism, such as a flexible hinge and protrusion.

[0395] A minimally invasive surgical method for implanting an alternative embodiment of an implant 4700 in the cervical spine is disclosed and taught herein. In this method, as shown in FIG. 171, preferably a guide wire 4080 is inserted through a placement network or guide 4090 into the neck of the implant recipient. The guide wire 4080 is used to locate where the implant 4700 is to be placed relative to the cervical spine, including the spinous processes. Once the guide wire 4080 is positioned with the aid of imaging techniques, an incision is made on the side of the neck so that an implant 4700 in accordance with an embodiment of the present invention, can be positioned in the neck through an incision and along a line that is about perpendicular to the guide wire 4080 and directed at the end of the guide wire 4080. In an embodiment, the implant 4700 can include a distraction guide 4710, a spacer 4720, a rod 4715 extending through the spacer 4720, and deployable first and second wings 4730, 4760. The implant 4700 can have a substantially flat profile to ease implantation, as described above. The implant 4700 is inserted into the neck of the patient. Preferably during insertion, the distraction guide 4710 pierces or separates the tissue without severing the tissue.

[0396] Once the implant 4700 is satisfactorily positioned, the first wing 4730 and the second wing 4760 can be deployed. As described above, the second wing 4760 can be deployed by urging the rod 4715 in a direction opposite the direction of insertion along the longitudinal axis 4725. As

the rod 4715 travels through the spacer 4720, hinged structures 4750-4753 contact the spacer 4720, buckle and extend away from the rod 4715 two form an upper end 4762 of the second wing and a lower end 4764 of the second wing. When second wing 4760 is satisfactorily deployed, the rod 4715 can be fixed in place relative to the spacer 4720 using a first stop 4782, a pin, or some other mechanism. The first wing 4730 can be deployed by urging the hinged structures 4754-4757 toward the spacer 4720, causing the hinged structures 4754-4757 to buckle and extend away from one another to form an upper end 4732 of the second wing and a lower end 4734 of the second wing. The anatomy of the neck is such that it is most convenient and minimally invasive to enter the neck from the side with respect to the implant 4700.

[0397] A minimally invasive surgical method for implanting an alternative embodiment of an implant 4900 in the cervical spine is disclosed and taught herein. In this method, as shown in FIG. 172, preferably a guide wire 4080 is inserted through a placement network or guide 4090 into the neck of the implant recipient. The guide wire 4080 is used to locate where the implant 4900 is to be placed relative to the cervical spine, including the spinous processes. Once the guide wire 4080 is positioned with the aid of imaging techniques, an incision is made on the side of the neck along a line that is about perpendicular to the guide wire 4080 and directed at the end of the guide wire 4080. The cannula 4995 is fed through the incision and positioned between the targeted adjacent spinous processes. In an embodiment, the implant 4900 can include a distraction guide 4910, a spacer 4920, a rod 4915 extending through the spacer 4920, and deployable first and second wings 4930, 4960. The implant 4900 can have a substantially circular cross-section to roughly conform with an inside surface of the cannula 4995. The implant 4900 is urged through the cannula 4995 and into position between the adjacent spinous processes so that the second wing 4960 hinge structures are clear of the cannula 4995, as described above in reference to FIG. 169B. The second wing 4960 is then deployed by urging the rod 4915 in a direction opposite the direction of insertion along the longitudinal axis 4925. As the rod 4915 travels through the spacer 4920, hinged structures 4950-4953 contact the spacer 4920, buckle and extend away from the rod 4915 two form an upper end 4962 of the second wing and a lower end 4964 of the second wing. When second wing 4960 is satisfactorily deployed, the cannula 4995 can be retracted to expose the hinged structures 4954-4957 of the first wing 4930. The first wing 4930 can be deployed by urging the hinged structures 4954-4957 toward the spacer 4920, causing the hinged structures 4954-4957 to buckle and extend away from one another to form an upper end 4932 of the second wing and a lower end 4934 of the second wing. Once the first wing 4930 is deployed, the rod 4915 can optionally be shortened, and the cannula 4995 can be withdrawn from the incision. The incision can then be closed.

[0398] The foregoing description of embodiments of the present invention has been provided for the purposes of illustration and description. It is not intended to be exhaustive or to limit the invention to the precise forms disclosed. Many modifications and variations will be apparent to the practitioner skilled in the art. The embodiments were chosen and described in order to best explain the principles of the invention and its practical application, thereby enabling others skilled in the art to understand the invention and the various embodiments and with various modifications that

are suited to the particular use contemplated. It is intended that the scope of the invention be defined by the following claims and their equivalence.

[0399] Additional aspects, objects and advantages of the invention can be obtained through a review of the appended claims and figures.

1.-21. (canceled)

22. An interspinous device for stabilizing at least one spinal motion segment comprising:

a first vertebra having a first spinous process and a second vertebra having a second spinous process, the device comprising:

an expandable member having an unexpanded configuration and an expanded configuration, wherein the expandable member in an expanded configuration has a size and shape configured for positioning between and providing distraction of the first and second spinous processes.

23. The device of claim 22, wherein the expandable member is a non-compliant balloon.

24. The device of claim 22, wherein the expandable member is a compliant balloon.

25. The device of claim 22, wherein the expandable member comprises a mesh material.

26. The device of claim 25, wherein the mesh material is coated with a non-porous material.

27. The device of claim 22, wherein the expandable member has a substantially H-shaped configuration.

28. The device of claim 22, wherein the expandable member comprises polyurethane.

29. The device of claim 22, further comprising at least one tab for anchoring the expandable member to the spinous processes.

30. The device of claim 29, further comprising a tether attached to the at least one tab.

31. The device of claim 22, further comprising at least one tether attached to the expandable member.

32. The device of claim 22, wherein the expandable member has a port for coupling to a source of an expansion medium.

33. The device of claim 22, wherein the port comprises a one-way valve mechanism.

34. The device of claim 22, wherein the expandable member is inflatable.

35. The device of claim 22, further comprising an expansion medium contained within the interior of the expandable member when in an expanded configuration.

36. The device of claim 22, further comprising at least one marker on a surface of the expandable member.

37. A system for stabilizing at least one spinal motion segment comprising:

a first vertebra having a first spinous process and a second vertebra having a second spinous process, the system comprising:

an expandable member having an unexpanded configuration and an expanded configuration, wherein the expandable member in an expanded configuration has a size and shape configured for positioning between and providing distraction of the first and second spinous processes, wherein the expandable member has a port; and

an expansion medium fillable within the interior of the expandable member via the port.

38. The system of claim 37, further comprising at least one anchor for securing the expandable member to the spinal motion segment.

39. The system of claim 38, wherein the at least one anchor is a screw configured for securing the expandable member to a spinous process.

40. The system of claim 37, wherein the expansion medium comprises polyurethane.

41. A kit for stabilizing at least one spinal motion segment comprising:

- a first vertebra having a first spinous process and a second vertebra having a second spinous process wherein a spinous ligament extends between the first and second spinous processes, the kit comprising:
 - at least one expandable member having an unexpanded configuration and an expanded configuration, wherein the at least one expandable member in an expanded configuration has a size and shape configured for positioning between and providing distraction of the first and second spinous processes; and
 - a cannula configured for percutaneous delivery to a target site within the spinal motion segment wherein the expandable member is deliverable through the cannula when in an unexpanded configuration.

42. The kit of claim 41, further comprising instructions for implanting the expandable member between the first and second spinous processes.

43. A method for stabilizing at least one spinal motion segment comprising:

- a superior vertebra and an inferior vertebra, the method comprising:
 - providing the device of claim 1;
 - forming an opening in the spinous ligament;
 - positioning the expandable member within the opening wherein the expandable member is in the unexpanded configuration; and
 - expanding the expandable member to the expanded configuration wherein the first and second vertebrae are distracted a selected distance.

44. The method of claim 43, wherein the expanding comprises inflating the expandable member with air.

45. The method of claim 44, the expanding further comprises filling the expandable member with a flowable medium.

46. The method of claim 43, wherein the steps of forming, positioning and expanding are performed through a percutaneous penetration in the patient's skin.

47. The method of claim 46, wherein the steps of forming, positioning and expanding are performed through a cannula positioned within the percutaneous penetration.

48. The method of claim 43, further comprising anchoring the expandable member to one or both of the spinous processes.

49. The method of claim 43, wherein the expandable member has a volume in the expanded configuration, the method further comprising adjusting the volume of the expandable member.

50. The method of claim 49, further comprising reducing the volume of the expandable member and removing the expandable member subsequent to reducing the volume.

51. A method for stabilizing at least one spinal motion segment comprising:

- a superior vertebra and an inferior vertebra, the method comprising:

- forming an opening in the spinous ligament;

- positioning an expandable member within the opening wherein the expandable member is in an unexpanded configuration; and

- selectively expanding the expandable member to an expanded configuration wherein the first and second vertebrae are distracted a selected distance.

52. An interspinous device for stabilizing at least one spinal motion segment comprising:

- a first vertebra having a first spinous process and a second vertebra having a second spinous process, the device comprising:

- an expandable member having an unexpanded configuration and an expanded configuration, wherein the expandable member in the unexpanded configuration has a size configured for positioning between the first and second spinous process and in the expanded configuration provides distraction of the first and second spinous processes, wherein the expandable member is mechanically actuatable from the unexpanded configuration to the expanded configuration.

53. The device of claim 52, wherein the expandable member comprises a plurality of parallel struts.

54. The device of claim 53, wherein the plurality of struts are affixed between two opposing hubs.

55. The device of claim 52, wherein the expandable member comprises a coiled band.

56. The device of claim 55, wherein the coiled band comprises inner and outer ends which are connectable to each other.

57. The device of claim 52, wherein the expandable member comprises a plurality of nested portions.

58. The device of claim 52, wherein the expandable member has a spherical configuration.

59. The device of claim 52, wherein the expandable member has an elliptical configuration.

60. The device of claim 52, wherein the expandable member has a disk configuration.

61. The device of claim 52, wherein the expandable member is self-expanding.

62. A system for stabilizing at least one spinal motion segment comprising:

- a first vertebra having a first spinous process and a second vertebra having a second spinous process, the system comprising:

- an expandable member having an unexpanded configuration and an expanded configuration, wherein the expandable member in the unexpanded configuration has a size configured for positioning between the first and second spinous process and in the expanded configuration provides distraction of the first and second spinous processes, wherein the expandable

member is mechanically actuatable from the unexpanded configuration to the expanded configuration; and

means for mechanically actuating the expandable member.

63. The system of claim 62, wherein said mechanical actuation means is a guide wire.

64. A method for stabilizing a vertebrae relative to another vertebrae, the method comprising:

introducing an expandable interspinous device to laterally of an interspinous space of the vertebrae;

expanding the interspinous device; and

inserting the interspinous device within the interspinous space.

65. The method of claim 64, further comprising: distracting the interspinous space prior to inserting the interspinous device.

66. The method of claim 65, wherein the distracting comprises introducing a device within the interspinous space and expanding the distracting device.

67. The method of claim 66, wherein the distracting device is a balloon.

68. The method of claim 66, wherein the distracting device is a mechanical device.

69. The method of claim 67, wherein the distracting device is introduced on one side of the interspinous space and the expandable interspinous device is introduced on the opposite side of the interspinous space.

70. The method of claim 67, wherein the distracting device and the expandable interspinous device are introduced on the same side of the interspinous space.

71. A kit for stabilizing at least one spinal motion segment comprising:

a first vertebra having a first spinous process and a second vertebra having a second spinous process, the kit comprising:

the interspinous device of claim 52; and

a cannula configured for percutaneous delivery to a target site within the spinal motion segment wherein the expandable member is deliverable through the cannula when in an unexpanded configuration.

72. The kit of claim 71, further comprising instructions for implanting the expandable member between the first and second spinous processes.

73. A method for stabilizing at least one spinal motion segment comprising a superior vertebra and an inferior vertebra, the method comprising:

providing the device of claim 52;

forming an opening in the spinous ligament;

positioning the expandable member within the opening wherein the expandable member is in the unexpanded configuration; and

expanding the expandable member to the expanded configuration wherein the first and second vertebrae are distracted a selected distance.

74. The method of claim 73, wherein the expanding comprises mechanical actuation.

75. The method of claim 73, wherein the steps of forming, positioning and expanding are performed through a percutaneous penetration in the patient's skin.

76. The method of claim 75, wherein the steps of forming, positioning and expanding are performed through a cannula positioned within the percutaneous penetration.

77. The method of claim 73, further comprising anchoring the expandable member to one or both of the spinous processes.

78. An interspinous device for stabilizing at least one spinal motion segment comprising:

a first vertebra having a first spinous process and a second vertebra having a second spinous process, the device comprising:

an axial dimension and a radial dimension substantially transverse to the axial dimension, wherein the axial dimension is greater when the device is in an undeployed configuration and the radially dimension is greater when the device is in a deployed configuration.

79. The interspinous device of claim 78, wherein the axial dimension is defined by a central member and the radial dimension is defined at least in part by a plurality of radially expandable members.

80. The interspinous device of claim 79, comprising a first strap extending between a first pair of the radially expandable members and a second strap extending between a second pair of the radially expandable members.

81. The interspinous device of claim 79, wherein the radially expandable members comprise linkages.

82. The interspinous device of claim 79, wherein the radially expandable members comprise deformable struts.

83. The interspinous device of claim 79, wherein the radially expandable members comprise a compressible material.

84. A system for stabilizing at least one spinal motion segment comprising:

a first vertebra having a first spinous process and a second vertebra having a second spinous process and an interspinous space defined between the first and second spinous processes, the system comprising:

the interspinous device of claim 78; and

a device for delivering the interspinous device in the undeployed state within the interspinous processes and for axially reducing and radially expanding the device from the undeployed state to the deployed state.

85. The system of claim 84, wherein the interspinous device is configured for delivery by the delivery device through a midline incision.

86. A method for stabilizing a vertebrae relative to another vertebrae wherein the vertebrae define an interspinous space, the method comprising:

introducing the interspinous device of claim 78 within the interspinous space when in the undeployed state; and

radially expanding and axially shortening the device to engage with the spinous processes.

87. The method of claim 86, further comprising forming an incision along the midline above the interspinous space, wherein the introducing the interspinous device comprises inserting the device within the midline incision.

88. An interspinous device for stabilizing at least one spinal motion segment comprising:

a first vertebra having a first spinous process and a second vertebra having a second spinous process, the device comprising:

a tubular member having a length and a diameter and being deployable from a first configuration to a second configuration, wherein one of the length and the diameter of the tubular member in the first configuration is changed when the tubular member is in the second configuration.

89. The device of claim 88 wherein the length of the tubular member in the first configuration is greater than the length of the tubular member in the second configuration.

90. The device of claim 88 wherein the diameter of the tubular member in the second configuration is greater than the diameter of the tubular member in the first configuration.

91. The device of claim 88 further comprising a retaining member circumferentially positioned about a portion of the length of the tubular member, wherein the diameter of the retained portion of the tubular member is less than the diameter of the unretained portion of the tubular member when the tubular member is in the second configuration.

92. The device of claim 91 wherein the diameter of the retained portion of the tubular member in the second configuration is sufficient to distract the first and second vertebrae relative to each other when the device is operably implanted between the first and second spinous processes.

93. The device of claim 91, wherein the retaining member is positioned about a central portion of the tubular member.

94. The device of claim 88, further comprising a core member positionable within the tubular member; and first and second hubs configured for coupling with a first end of the core member and a second end of the core member, respectively.

95. The device of claim 94, wherein the at least one of the hubs is configured to translate axially over the core member.

96. The device of claim 94, wherein the core member comprises segments of length which are removable from the core member.

97. The device of claim 88, wherein the tubular member comprises a polymer material.

98. The device of claim 88, wherein the retaining member comprises a braided or mesh material.

99. The device of claim 88, wherein a luminal surface of the tubular member is contoured.

100. A system for stabilizing at least one spinal motion segment comprising:

a first vertebra having a first spinous process and a second vertebra having a second spinous process, the system comprising:

the interspinous device of claim 88; and

a device for delivering the interspinous device when in the first configuration between the first and second spinous process and for deploying the interspinous device in the second configuration.

101. The system of claim 98 wherein the delivery device comprises:

an elongated shaft having a detachable distal end configured for insertion into the tubular member of the interspinous device; and

a handle mechanism for moving the elongated shaft wherein the movement causes the tubular member to be deployed from the first configuration to the second configuration.

102. A method for stabilizing a vertebrae relative to another vertebrae wherein the vertebrae define an interspinous space, the method comprising:

introducing the interspinous device of claim 88 within the interspinous space when in the first configuration; and

deploying the interspinous device to the second configuration.

103. A device for stabilizing at least one spinal motion segment comprising a first vertebra having a first spinous process and a second vertebra having a second spinous process, the device comprising:

an undeployed configuration having an axial dimension and a radial dimension substantially transverse to the axial dimension; and a deployed configuration having an axial dimension and a radial dimension substantially transverse to the axial dimension;

wherein the radial dimension of the undeployed configuration is less than the radial dimension in the deployed configuration.

104. The device of claim 103, wherein the axial dimension of the undeployed configuration is greater than the axial dimension in the deployed configuration.

105. The interspinous device of claim 103, wherein the radial dimension is defined at least in part by a plurality of radially expanding members.

106. The device of claim 105, wherein the radially expanding members comprise deformable struts.

107. The device of claim 105, wherein the radially expanding members comprise linkages.

108. The device of claim 105, comprising a first bracket extending between a first pair of the radially expandable members and a second bracket extending between a second pair of the radially expandable members.

109. The device of claim 107, wherein the brackets each comprise a substantially rigid central portion and two substantially flexible lateral portions.

110. The device of claim 103, wherein the device in the undeployed has a cylindrical shape.

111. The device of claim 103, wherein the device in the deployed has a "X" shape.

112. A system for stabilizing at least one spinal motion segment comprising:

a first vertebra having a first spinous process and a second vertebra having a second spinous process and an interspinous space defined between the first and second spinous processes, the system comprising:

the device of claim 103; and

a device for delivering the device in the undeployed configuration within the interspinous processes and for radially expanding the device from the undeployed configuration to the deployed configuration.

113. The system of claim 112, wherein the device is configured for delivery by the delivery device through a midline incision.

114. A method for stabilizing a vertebra relative to another vertebra wherein the vertebrae define an interspinous space therebetween, the method comprising:

introducing the device of claim 103 within the interspinous space when in the undeployed configuration; and

radially expanding the device to selectively distract the spinous processes.

115. The method of claim 114, further comprising forming an incision along the midline above the interspinous space, wherein the introducing the interspinous device comprises inserting the device within the midline incision.

116. A posterior element distraction system for implantation at a spinal motion segment comprising a superior vertebra, an inferior vertebra, each vertebra comprising a posterior element comprising a spinous process, laminal portions and a set of facet joints, and further comprising an interspinous space between the spinous processes, the system comprising:

at least one lateral member for positioning on a side of the spinal motion segment and outside the interspinous space, wherein the at least one lateral member has an unexpanded configuration and an expanded configuration; and

first and second transverse members extending transversely from the at least one lateral member, wherein when the system is operatively implanted at a spinal motion segment and the at least one lateral member is in an expanded configuration, the transverse members are caused to contact a portion of either the superior or inferior posterior elements thereby providing distraction between the superior and inferior posterior elements.

117. The system of claim 116, wherein the system comprises two lateral members for positioning on opposite sides of spinal motion segment.

118. The system of claim 117, wherein each transverse member is a strap extending between the two lateral members.

119. The system of claim 117, further comprising a meshing about the two lateral members.

120. The system of claim 116, wherein the system comprises only one lateral member.

121. The system of claim 116, wherein the at least one lateral member comprises a balloon configuration.

122. The system of claim 117, wherein the at least one lateral member comprises a strut configuration.

123. The system of claim 118, wherein the at least one lateral member comprises a balloon and a strut.

124. The system of claim 116, wherein the transverse members have a pre-formed configuration.

125. The system of claim 116, wherein the transverse members have a flexible configuration.

126. A system for implanting the system of claim 116, the implantation system comprising:

a temporary distraction device having an expanded configuration and an unexpanded configuration and further configured for insertion within the interspinous space, wherein upon expansion of the device, the superior and inferior vertebrae are distracted from each other.

127. The system of claim 126, further comprising:

a working channel for delivering the temporary distraction device and the posterior distraction system, wherein the temporary distraction device is deliverable in an unexpanded configuration.

128. The system of claim 127, wherein the temporary distraction device and the posterior distraction system are deliverable simultaneously to the spinal motion segment.

129. The system of claim 126, wherein the temporary distraction device comprises a balloon.

130. A method for distracting at least a portion of a spinal motion segment comprising:

a superior vertebra, an inferior vertebra, each vertebra comprising a posterior element comprising a spinous process, laminal portions and a set of facet joints, and further comprising an interspinous space between the spinous processes, the method comprising:

inserting an expandable member laterally of the spinal motion segment; and

expanding the expandable member thereby distracting the superior vertebra and the inferior vertebra relative to each other.

131. The method of claim 130, further comprising:

inserting two transverse members within the interspinous space.

132. The method of claim 130, wherein the distraction between the vertebrae is along the longitudinal axis of the spine.

133. The method of claim 130, wherein the distraction between the vertebrae is rotational.

134. A method for distracting at least a portion of a spinal motion segment comprising:

a superior vertebra, an inferior vertebra, each vertebra comprising:

a posterior element comprising a spinous process, laminal portions and a set of facet joints, and further comprising an interspinous space between the spinous processes, the method comprising:

distracting the superior vertebra and the inferior vertebra relative to each other until a desired amount of distraction is achieved;

inserting an implantable expandable member within the interspinous space; and

expanding the implantable expandable member to contact the spinous processes thereby maintaining the distraction achieved.

135. The method of claim 134, wherein the distracting comprises using another expandable member positionable within the interspinous space; and wherein the other expandable member is removed subsequent to the expanding of the implantable expandable.

* * * * *