



INTERNATIONAL APPLICATION PUBLISHED UNDER THE PATENT COOPERATION TREATY (PCT)

<p>(51) International Patent Classification⁵ : H01M 4/68</p>	<p>A1</p>	<p>(11) International Publication Number: WO 94/19837 (43) International Publication Date: 1 September 1994 (01.09.94)</p>
<p>(21) International Application Number: PCT/US93/01714 (22) International Filing Date: 24 February 1993 (24.02.93) (71) Applicant (for all designated States except US): TROJAN BATTERY COMPANY [US/US]; 12380 Clark Street, Santa Fe Springs, CA 90670 (US). (72) Inventor; and (75) Inventor/Applicant (for US only): BRECHT, William, B. [US/US]; 242 6th Street, Seal Beach, CA 90740 (US). (74) Agent: CARNEY, Hayden, A.; Christie, Parker & Hale, 350 West Colorado Boulevard, Suite 500, P.O. Box 7068, Pasadena, CA 91109-7068 (US).</p>	<p>(81) Designated States: AT, AU, BB, BG, BR, BY, CA, CH, CZ, DE, DK, ES, FI, GB, HU, JP, KP, KR, LK, LU, MG, MN, MW, NL, NO, NZ, PL, RO, RU, SD, SE, SK, UA, US, European patent (AT, BE, CH, DE, DK, ES, FR, GB, GR, IE, IT, LU, MC, NL, PT, SE), OAPI patent (BF, BJ, CF, CG, CI, CM, GA, GN, ML, MR, SN, TD, TG).</p> <p>Published <i>With international search report.</i> <i>With amended claims.</i></p>	

(54) Title: AN ELECTRODE PLATE CONSTRUCTION

(57) Abstract

A battery electrode (12) for use in an electrolytic bipolar battery (10) comprises a structurally rigid and electrically conductive core member (18), at least one corrosion resistant layer (20), an interface layer (22), a positive-side active layer (14) and a negative-side active layer (26). The corrosion resistant layer (20) is in intimate contact with and is interposed between one surface of the core member (18) and the interface layer (22). The corrosion resistant layer is comprised of a material which can participate in a corrosive electrochemical reaction with the material of the positive active layer, but does so less effectively than does the interface layer. The interface layer (22) is in intimate contact with and is interposed between the corrosion resistant layer (20) and the positive-side active layer (14). The negative-side active material (26) is in intimate contact with the surface of the core member opposite the core member surface carrying the corrosion resistant layer. The margins of the electrode are connected to nonconductive components (30) of the battery which space plural ones of the electrodes from each other. Those connections are made via marginal surface portions (40) of the electrodes from which oxides (36) have been removed. The connections form seals which are secure from leakage of electrolyte through the seals.

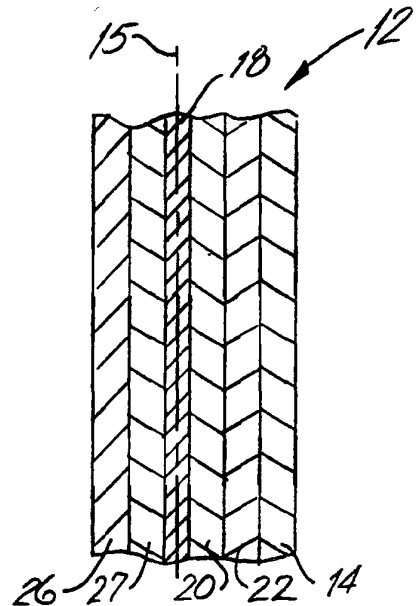

FOR THE PURPOSES OF INFORMATION ONLY

Codes used to identify States party to the PCT on the front pages of pamphlets publishing international applications under the PCT.

AT	Austria	GB	United Kingdom	MR	Mauritania
AU	Australia	GE	Georgia	MW	Malawi
BB	Barbados	GN	Guinea	NE	Niger
BE	Belgium	GR	Greece	NL	Netherlands
BF	Burkina Faso	HU	Hungary	NO	Norway
BG	Bulgaria	IE	Ireland	NZ	New Zealand
BJ	Benin	IT	Italy	PL	Poland
BR	Brazil	JP	Japan	PT	Portugal
BY	Belarus	KE	Kenya	RO	Romania
CA	Canada	KG	Kyrgyzstan	RU	Russian Federation
CF	Central African Republic	KP	Democratic People's Republic of Korea	SD	Sudan
CG	Congo	KR	Republic of Korea	SE	Sweden
CH	Switzerland	KZ	Kazakhstan	SI	Slovenia
CI	Côte d'Ivoire	LI	Liechtenstein	SK	Slovakia
CM	Cameroon	LU	Luxembourg	SN	Senegal
CN	China	LK	Sri Lanka	TD	Chad
CS	Czechoslovakia	LV	Latvia	TG	Togo
CZ	Czech Republic	MC	Monaco	TJ	Tajikistan
DE	Germany	MD	Republic of Moldova	TT	Trinidad and Tobago
DK	Denmark	MG	Madagascar	UA	Ukraine
ES	Spain	ML	Mali	US	United States of America
FI	Finland	MN	Mongolia	UZ	Uzbekistan
FR	France			VN	Viet Nam
GA	Gabon				

1

5

-1-

10

AN ELECTRODE PLATE CONSTRUCTION

Field of the Invention

This invention relates to the construction of a battery electrode plate that is resistant to chemical attack and corrosion, and provides an electrolyte-tight seal.

15

Background of the Invention

20

Even though there has been considerable study of alternative electrochemical systems, the lead-acid battery is still the battery of choice for general purposes such as starting a vehicle, boat or airplane engine, emergency lighting, electric vehicle motive power, energy buffer storage for solar-electric energy, and field hardware, both industrial and military. These batteries may be periodically charged from a generator or other source of suitable DC power.

25

The conventional lead-acid battery is a multi-cell structure. Each cell generally comprises a set of vertical interdigitated monopolar positive and negative plates formed of lead or lead-alloy grids containing layers of electrochemically active pastes or active materials. The paste on the positive electrode plate when charged comprises lead dioxide (PbO_2), which is the positive active material, and the negative plate contains a negative active material such as sponge lead. An acid electrolyte based on sulfuric acid is interposed between the positive and negative plates.

30

Lead-acid batteries are inherently heavy due to the use of the heavy metal lead in constructing the plates. Modern attempts to produce light-weight lead-acid batteries, especially in the aircraft, electric car and vehicle fields, have placed their emphasis on producing thinner plates from lighter weight materials used in place of and in combination with lead. The thinner plates allow for the use of more plates for a given volume, thus increasing the power density of a conventional lead-acid battery. However, the extent to which conventional battery performance can be improved upon is limited by its inherent construction.

35

1 Bipolar batteries are not new and have been known for some time and offer the
potential for improvement over monopolar battery technology. Bipolar battery
construction comprises a series of electrode plates that each contain a negative active
material on one side and a positive active material on the other side, hence the terms
5 "bipolar" and "biplate". The biplates are serially arranged in such a fashion that the
positive side of one plate is directed toward the negative side of an opposing plate.
The bipolar battery is made up of separate electrolytic cells that are defined by biplates
of opposing polarities. The biplates must be impervious to electrolyte and be
electrically conductive to provide a serial connection between cells.

10 The bipolar battery is characterized by having improved current flow over that
of conventional monopolar batteries. The enhanced current flow is the result of
through-plate current transfer from one polarity of the biplate to the other. In a
conventional monopolar battery the current must travel from one electrode plate to
another of opposite polarity via a conductive path which commonly is circuitous and
15 of relatively considerable length. The significantly shortened intercell current path
inherent in the bipolar battery reduces the battery's internal resistance, making it more
efficient than the conventional monopolar battery in both discharging and charging
modes of operation. This reduced internal resistance permits the construction of a
bipolar battery that is both smaller and lighter than its equivalent monopolar battery,
20 making it a highly desirable alternative for use in the aircraft, military and electric
vehicle industry where considerations of size and weight are of major importance.

 The bipolar battery, however, is not without its own difficulties and problems
which, heretofore, have resisted efficient resolution and solution. A first such
difficulty is related to the choice of materials for the conductive sheet used to make up
25 the biplate. The bipolar construction in its simplest form would use lead or lead alloy
for the conductive sheet and intercell partition. However, since the lead of the
conductive sheet is corroded at the positive (anode) side by both the action of
overcharge (recharge) and by the current-producing interaction between the conductive
sheet and the active material itself (discharge), in time the lead sheet will be corroded
30 entirely through from the positive side. Once penetrated, the electrolyte from the cell
on the positive side has direct contact with the electrolyte on the negative side and a
short circuit is established between adjacent cells. In short order, the positive material
on one side of the now-penetrated conductive sheet becomes fully discharged against
the negative active material on the opposite side.

35 This short circuit condition will result not only in a loss of voltage from the
two cells, but will also introduce a very high resistance in the series-connected bipolar
cells due to the near total conversion of both active materials to lead sulfate, which is

1 nonconducting. The greatly increased resistance will render the battery nearly useless
at all but very low discharge rates and will entirely defeat the fundamentally low
resistance inherent in bipolar construction.

5 Another problem in the construction of the bipolar battery is one inherent with
the construction of lead-acid batteries in general. This involves achieving an
electrolyte-tight seal about a conductive battery member passing from a position inside
the battery and in intimate contact with the battery electrolyte through the battery
housing to the battery's outside surface. In a conventional monopolar lead-acid battery,
10 problems of unwanted electrolyte leakage occurs at the terminal post seal where a
terminal post (conductive member) passes through the battery cell cover. The unique
electro-chemistry occurring at such seal interface predicts that a true seal cannot be
obtained so long as an oxide film exists on the conductive member. Eventually the seal
will fail either by creep corrosion, resulting in the migration of the electrolyte to the
battery surface, or around the end of the conductive member to the adjacent cell, or
15 fail by crevice corrosion (also called nodular corrosion) resulting in the mechanical
separation or failure of the seal.

The problem related to achieving an electrolyte-tight seal about a conductive
battery member in intimate contact with the battery electrolyte as the conductive
member passes through the battery housing is well known and understood in the art and
20 was addressed in a paper entitled "Vulcanized Rubber Post Seal For Lead-Acid
Batteries A New Generic Type" presented before the 1988 INTELEC International
Telecommunications Energy Conference. The paper identified two different types of
corrosion mechanisms, creep and crevice or nodular corrosion, that was responsible
for electrolyte migration in electrolytic batteries.

25 In bipolar battery construction, a bipolar plate is the conductive member which
is in intimate contact with the battery electrolyte. The bipolar plate extends from its
position in contact with the electrolyte to a position at its edges where it is sealed to
a barrier between adjacent cells; it may extend to an exterior surface of the battery.
At the position defining the battery surface the biplate must interact with other battery
30 components to form an electrolyte-tight seal. The problem of achieving an electrolyte-
tight seal is exacerbated in bipolar construction because the electrolyte-tight seal must
occur about the full perimeter of each biplate, making the total area of seal much
greater than that encountered in conventional monopolar battery construction.

35 It is seen, therefore, that a need exist for a bipolar battery electrode plate
construction that will afford improved protection from chemical and electrolytic attack,
serving to both extend battery service life and improve the predictability of battery
performance. It is desirable that the electrode plate be constructed using methods

1 commercially and economically feasible from materials readily and practically
available. It is also desirable that the electrode plate construction facilitate the
reclamation and recovery of recyclable materials used in battery construction. Further,
5 it is highly desirable that the battery electrode plate be constructed in a manner
facilitating an electrolyte-tight seal when used in conjunction with other battery
members.

10

15

20

25

30

35

1 **Summary of the Invention**

 This invention addresses and fulfills the need identified above. It does so by providing an electrode plate structure for a bipolar battery which is of reduced weight and has a long life expectancy. The bipolar electrode and the overall battery are
5 manufacturable by economic and efficient procedures. The battery materials are well known and readily amendable to established reclamation and recycling process. The electrode can be sealed to other battery components in a manner which effectively resists leakage during the useful life of the battery.

 Generally speaking, in terms of structure, this invention provides an electrode
10 construction for an electrolytic bipolar battery, which construction includes a structurally rigid and electrically conductive core member. At least one corrosion resistant layer, comprising a material which is both corrosion resistant and able to participate in the electrochemical reaction, is in intimate interface with the surface of the conductive core member. An interface layer, comprising a material that both
15 substantially participates in the electrochemical reaction and fuses or forms an intimate interface with a positive-side active material, is in intimate interface with the surface of the corrosion resistant layer. A positive-side active layer, comprising a material that is capable of substantial participation in the electrochemical reaction at the anodic or positive side of the electrode plate, is in intimate interface with the surface of the
20 interface layer. A negative-side active layer, comprising a material that is capable of substantial participation in the electrochemical reaction at the cathodic or negative side of the electrode plate, is in intimate interface with the surface of the conductive core member opposite the core member surface accommodating the corrosion resistant layer.

 The electrode plate may comprise a single corrosion resistant layer or a
25 plurality of corrosion resistant layers. With respect to an electrode plate comprising more than one corrosion resistant layer, each corrosion resistant layer can exhibit a decreased degree of corrosion resistance and an increased degree of participation in the electrochemical reaction as a function of distance from the electrode core member. A preferred corrosion resistant layer may comprise pure lead or a lead-alloy selected from
30 the group consisting of lead-tin, lead-indium, lead-calcium, lead-silver, lead-aluminum, and lead-antimony or any combination thereof.

 With respect to the interface layer, a preferred material may comprise either
35 pure lead or a lead-alloy selected from the group consisting of lead-tin, lead-indium, lead-calcium, lead-silver, lead-aluminum, and lead-antimony or any combination thereof. With respect to the positive-side active layer, a preferred material is lead dioxide. With respect to the negative-side active layer, a preferred material is sponge lead.

1 The corrosion resistant layers and interface layer are applied by metal cladding
or similar process which results in the formation of metallurgical bonds between the
layers. The positive-side and negative-side active materials are applied to respective
sides of the electrode plate by conventional application methods well known by those
5 skilled in the art.

 The electrode plate is a conductive battery member which can extend from a
position within the battery in intimate contact with the battery electrolyte, through a
seal zone defined by another battery component or the battery housing and to the
outside battery surface. The conductive battery member is prepared for use in forming
10 an electrolyte-tight seal by striping the oxides away from a portion of the surface of the
conductive battery member that lies within the seal zone. In a non-oxidizing
atmosphere, the deoxidized conductive surface is coated with a protective layer that is
oxygen impermeable, chemically and electrochemically stable, and capable of joining
with the battery housing or nonconductive battery component to form an electrolyte-
15 tight seal. The battery is constructed, and an electrolyte-tight seal is achieved, by
placing the protected portion of the conductive member within the seal zone and
causing the protected portion of its surface to intimately mate with and connect to
another battery component or the battery housing.

20

25

30

35

1 **Description of the Drawings**

 The above-mentioned and other features of this invention are set forth in the following detailed description of the presently preferred and other embodiments of the invention, which description is presented with reference to the accompanying drawings
5 wherein:

 FIG. 1 is a perspective view of a bipolar battery comprising the electrode plate provided in the practice of this invention;

 FIG. 2 is a perspective view of an electrode plate as provided in the practice of this invention;

10 FIG. 3 is a cross-sectional view of one embodiment of the electrode plate;

 FIG. 4. is a cross-sectional view of one another embodiment of the electrode plate;

 FIG. 5 is an exploded perspective view illustrating the interrelationship of an electrode plate with other battery components in the construction of a bipolar battery;

15 FIGs. 6(a) through 6(e) are a series of enlarged cross-sectional views of an electrode plate illustrating successive stages in the corrosion of the electrode plate during its useful life;

 FIG. 7. is a graphic depiction of the variation in composition of a metallic layer interposed between the electrode core member and the positive-side active material in the practice of this invention showing the variation of the material
20 composition through the layer;

 FIGs. 8(a) through 8(e) are enlarged cross-sectional views illustrating progressive steps in a method practice of this invention for providing an electrolyte-tight seal about the peripheral portion of an electrode plate;

25 FIG. 9 is a cross-sectional view of another embodiment of the method for providing an electrolyte-tight seal; and

 FIG. 10 is a fragmentary cross-sectional elevation view illustrating another method for providing an electrolyte-tight seal at a marginal edge of an electrode plate for a bipolar battery.
30

Detailed Description

1 The construction of an electrode plate for use in a battery is generally not a
large concern when the battery is a conventional monopolar lead-acid type battery. In
the conventional lead-acid battery, each positive and negative electrode plate is typically
5 made from lead. Each electrode is of only one polarity on each of its sides, hence the
name monopolar. Lead and alloys of lead are chosen as the preferred electrode
material for two reasons. First, it has an ability to participate in the electrochemical
reaction that creates the flow of electrons or current flow of the battery. Second, it has
an ability to fuse with and form an intimate contact with the active material at the
10 surface of the electrode plate. The positive and negative electrodes in a conventional
battery are arranged in a repeating pattern of negative and positive plates separated by
a nonconductive member. The plates are immersed in an acid electrolyte which
facilitates the ion transfer and electrochemical reaction between plates of opposing
polarities. A cell in a conventional monopolar battery comprises a group of electrode
15 plates, a volume of electrolyte, and a cell partition usually made from a
nonconductive/chemically inert polymeric material.

 The construction of a bipolar battery involves the placement of an electrically
conductive sheet between adjacent cells of the battery such that separation of the
electrolyte in the respective cells is maintained by the conductive sheet. Positive active
20 material is applied to one side of the sheet, while negative active material is applied to
the opposite side. In this way, the positive active material is exposed to the electrolyte
of one cell and the negative active material is exposed to the electrolyte of the adjacent
cell. The conductive sheet thereby forms a single structure electrically connecting two
adjacent half cells, one positive and one negative. By repeating this arrangement of
25 conductive sheets separating successive cells, a battery of any desired voltage can be
constructed simply by building up the required number of cells into a stack.

 In its simplest form, the conductive sheet between the cells to which the active
materials are applied can be metallic lead or lead alloy, as is true with conventional
monopolar lead-acid batteries. The only requirement which must be observed is that
30 the sheet be truly continuous (without holes) and be sealed at its perimeter to preclude
contact between the electrolyte of adjacent cells along paths around the edges of the
electrode. The conductive sheet in a bipolar battery serves multiple functions in the
completed cell: that of intercell partition, and that of current collector for active
materials in each of the adjacent cells. Because the electrically conductive sheet holds
35 or is in contact with active materials of both positive and negative polarity, it is said
to be bipolar (or two poles). When this construction method is utilized, the conductive

1 sheet with both active materials attached is called a biplate, and the stacked series of
biplates is called a bipolar battery.

5 An advantage of bipolar batteries over conventional monopolar batteries lies
in the reduction of internal resistance which is directly related to its construction. In
a conventional monopolar battery the electron transfer generated by the electrochemical
reactions occurring at the active surfaces of each electrode must progress through the
active material of each electrode, through a conductor to a plate of opposite polarity
10 in an adjacent battery cell, and then through the active material of that plate in merely
moving from one cell to the next within the battery; that path is then repeated, on
average, as an electron moves from cell to cell in a monopolar battery before reaching
the battery negative terminal where it is available for use as electric current. The total
electron path in a monopolar battery can be quite long. This path of current flow is
15 characterized by an inherent resistance (lead is not highly conductive) which causes a
reduction in the current output of the battery.

Because of the bipolar nature of each electrode plate in a bipolar battery, the
electron transfer occurs through the thickness of the biplate. The biplate thickness is
many times smaller than the intercell electron path length in a monopolar battery,
decreasing the internal resistance of the bipolar battery. This reduced internal
resistance permits the construction of a bipolar battery that is both smaller and lighter
20 than its equivalent monopolar battery, making it a highly desirable alternative for use
in the aircraft, military and electric vehicle industry where considerations of size and
weight are of major importance.

The biplate of a bipolar battery is required to serve many different functions.
The biplate must: (1) participate in the electrochemical reaction causing the evolution
of free electrons, (2) serve as a cell partition, preventing the migration of electrolyte
25 between adjacent cells, (3) intimately and effectively support the relevant active
materials of a battery cell, (4) conduct electricity as efficiently as possible, and (5) due
to the inherent construction of the bipolar battery, cooperate with other battery
components to form an electrolyte-tight seal about the biplate edges which may be on
30 the battery's outside surface. Therefore, the material chosen for the biplate is an
important consideration in the construction of an effective, long lasting bipolar battery.

There are many factors which influence the materials suitable for use as battery
electrode plate. For example, the electrode plate must be both structurally rigid to
support the active surface during the life of the battery, and it must be chemically and
35 electrochemically stable as well. Lead and certain alloys of lead are not well suited for
use as biplates in a lead acid bipolar battery, even though they have superior ability to
fuse with and support positive and negative active materials for such batteries. Lead

1 at the positive side of the biplate is corroded both by the action of overcharge and by
the very interaction with the active material, lead dioxide (PbO_2) which is essential to
the current creation process. Thus, in time, a lead biplate would be corroded entirely
through from the positive side. Once the biplate is penetrated, the electrolyte from the
5 positive side of the biplate will come in direct contact with electrolyte at the negative
side and a short circuit will be established between adjacent cells, thereby causing the
positive active material on one side of the biplate to be rapidly fully discharged against
the negative active material on the opposite side. That short circuit will greatly
increase the internal resistance of the battery.

10 To preclude the failure of an entire stack of bipolar cells due to corrosion
penetration of one conductive intercell partition, it is necessary that the partition
include a conductive material which is sufficiently chemically resistant to the action of
strong acids and electrochemically resistant to the action of oxidation so that through-
corrosion of the partition cannot occur within the life of other components of the
15 battery. Only relatively recently have materials which met the criteria of being
conductive but completely chemically inert become available in the form of conductive
polymers. However, such polymers are unsuited for use as a conductive material in
the construction of a bipolar battery because they are unable to withstand the
electrochemical oxidation action that occurs at the positive-side active material and are
20 unable form a bond with and intimately interface with the battery active material.

In the conventional monopolar lead-acid battery construction, the establishment
of a satisfactory boundary layer interface between the active material and the current
collector relies upon a complex chemistry of intermediate oxides and corrosion
products produced from the metallic current collector itself. Corrosion of the current
25 collector, then, is a necessary prerequisite for making and maintaining contact between
the conductive sheet of the biplate and the active material, particularly at the positive
side. If non-corroding materials are used to fabricate the conductive intercell partition
of a bipolar battery, then the corrosion necessary for satisfactory interface between the
conductive partition and the active material would not be formed and, consequently,
30 electrical performance would not be realized.

An electrode plate 12 (FIG.2) constructed according to the present invention
is used in the construction of a bipolar battery 10 shown in FIG. 1. In that bipolar
battery, the electrode plates (biplates) are stacked in serial fashion, progressing from
the front to the rear of the battery, defining both the length and the cross-sectional
35 shape of the battery. FIG. 1 illustrates an embodiment of the bipolar battery having
bipolar plates shaped in the configuration of a square or rectangle, but other plate
configurations, such as a circle, oval, hexagon and the like, can be used if desired.

1 FIGs. 2 and 3 illustrate a preferred embodiment of electrode plate 12 according
to the present invention. The electrode plate comprises a positive-side active material
14 at the surface of its positive side. A protective coating 16 surrounds the edge and
periphery of both the negative and positive sides of the electrode plate. As shown in
5 FIG. 3, biplate 12 comprises a core member 18 that serves as a structurally rigid
conductive member for the electrode plate. With respect to the positive (anodic) side
of the electrode plate to the right of dashed line 15, a corrosion resistant layer 20 is in
intimate contact with the core member 18. The corrosion resistant layer 20 is
interposed between the core member and an interface layer 22 capable of both
10 substantial participation in the desired electrochemical reaction and of fusing and
forming an intimate interface with the positive-side active material 14. The interface
layer 22 is interposed between the corrosion resistant layer 20 and the positive-side
active material 14. The positive-side active layer occupies the positive-side surface of
the electrode plate and is fused to or intimately carried by the interface layer 22. With
15 respect to the negative (cathodic) side of the electrode to the left of dashed line 15, a
negative-side active material 26 is carried in intimate relation by an adjacent face of a
cathode liner 27 which covers the cathodic side of core member 18.

 With respect to electrode core member 18, it is desired that it be structurally
rigid, electrically conductive and facilitate the reclamation and recovery of recyclable
20 materials used to construct the battery. It is not necessary that the core member be
chemically or electrochemically stable as previously required in bipolar battery
construction. The reason for this is that the corrosion resistant layer 20 protects the
core member from corrosion by chemical and electrochemical processes during the
useful life of the battery 10.

25 Suitable materials for electrode core member 18 may include known metals and
metal alloys such as carbon steel, copper, aluminum, iron, stainless steel and the like.
However, other materials such as graphite prepreg, ceramics, and carbon based
materials as well as conductive polymers such as metal epoxies, metal polyolefins,
metal thermoplastics, metal thermosets, and metal polycarbonates, polymer composites
30 with conductive additives of SnO_2 , Ti_4O_7 , and graphite/carbon particulate or fiber and
the like may also be used. These and other suitable core materials may contain the
conductive metal material in the form of either grains or fibers. In general, any type
of material that possesses the requisite structural strength and the ability to conduct
electricity can be used to make the core member of the present invention. Materials
35 having high ratios of strength to weight are preferred.

 Preferred core member materials include carbon steel, iron and aluminum. A
particularly preferred material is carbon steel because it is readily reclaimable and

1 recyclable. Although the use of aluminum would be advantageous because of its
relatively light weight, its use would adversely affect the ability to reclaim and recover
the recyclable the materials otherwise used in constructing the battery 10. As
5 illustrated in FIG. 2, the core sheet can be configured as a rectangular flat of a given
thickness. However, the particular size of the core sheet is ultimately dependant on
its particular application. For instance, a core sheet may be configured to
accommodate its use in an electric wrist watch, calculator, or camera. At the other
extreme, a core sheet may be configured to accommodate its use in a submarine or
10 commercial airplane. As an example, a core sheet used to power an electric vehicle
can be configured in the shape of a rectangle having approximate dimensions of 25 by
20 centimeters and a thickness in the range of from 0.2 to 0.8 millimeters. A
particularly preferred electrode core member may have a thickness of approximately
0.4 millimeters. Although the preferred shape of the core member is rectangular, other
15 configurations such as square, round, oval, hexagonal and the like may also be used.
In addition, the core member may be configured other than at a flat sheet; for example,
the core member may be corrugated for strength and rigidity or for other reasons.

As to the layer 20 of corrosion resistant material, it is desired that this material
be chosen from a class of materials which is corrosion resistant to some extent and
which participates in the battery's positive electrochemical reaction to some extent. It
20 is desired that the corrosion resistant layer exhibit simultaneous properties of corrosion
resistance and electrochemical participation in an inversely related manner. For
example, a corrosion resistant material having high corrosion resistant properties should
display a low degree of electrochemical participation.

25 These simultaneous characteristics and their inverse relationship is particularly
desirable to assure a gradual increase in the corrosion penetration resistance of the
electrode plate, moving from the active material to the core member, to prevent the
sudden corrosive penetration of the core member and the resulting sudden decrease in
battery performance. The corrosion resistant layer is interposed between core member
18 and the substantially less corrosion resistant layer 22 which actively participates self-
30 destructively in the desired electrochemical processes with active material 14 in the
presence of an electrolyte from which core member 18 is protected by layer 20. Layer
22 is a corrodible layer. When the corrodible layer is penetrated by the battery
electrolyte, as it necessarily will be in due course as a consequence of use of the
battery, the electrolyte will interact with the less active corrosion resistant layer,
35 providing a heightened degree of corrosion penetration resistance to the core member.

With respect to lead-acid batteries and the related electrochemical reaction, a
material comprising lead provides the degree of electrochemical participation desired.

1 The concurrently desired corrosion resistant characteristic may be acquired by using
a lead alloy comprising a material that is both chemically compatible with lead and
corrosion resistant when alloyed with lead. Preferred materials for constructing the
corrosion resistant layer may comprise pure lead or a lead alloy selected from the
5 group consisting of lead-indium, lead-calcium, lead-tin, lead-silver, lead-aluminum, and
lead-antimony or any combination thereof. Other alloying agents such as polonium,
copper, arsenic, sulfur, cadmium, bismuth, and zinc may be added to the chosen lead
alloy in order to change the physical properties of the corrosion resistant layer. A
preferred corrosion resistant layer may comprise up to approximately 0.1 percent by
10 weight of these additional alloying agents.

A particularly preferred material for constructing corrosion resistant layer 20
is one comprising lead-tin (PbSn) alloy. Lead-tin alloy is particularly preferred because
of its low relative cost and its ready availability. A lead-silver alloy would provide the
best corrosion resistance, but it has relatively high material cost. A preferred lead-tin
15 alloy comprising lead-tin comprises in the range of from 0.01 to 5 percent by weight
tin and has a thickness in the range of from 0.04 to 0.2 millimeters. A lead-tin alloy
comprising less than 0.01 percent by weight tin will not exhibit the degree of corrosion
resistance desired to protect the core member from chemical and electrochemical
attack. A lead-tin alloy comprising greater than 5 percent by weight tin will not
20 participate in the electrochemical reaction to the degree desired to maintain optimal
battery performance upon exposure with the battery electrolyte. A particularly
preferred corrosion resistant layer comprises approximately 2 percent by weight tin and
has a thickness of approximately 0.08 millimeters. In order to achieve enhanced
corrosion protection a small amount of silver (Ag) in the range of from 0.001 to 1
25 percent by weight may be added to the lead alloy (i.e., lead-tin) or to any combination
of alloys chosen for the corrosion resistant layer. A particularly preferred corrosion
resistant layer comprises approximately 0.3 percent by weight silver.

The corrosion resistant layer may be joined to the surface of the core member
by using known techniques that causes two materials to intimately interface with and
30 bond to each other including the use of cladding, conductive adhesives, compression
welding, hot dip coating, fluid film deposition, and plating or the like. A cladding
process is preferred because such a process creates an intimate metallurgical bond
between the two dissimilar materials. An intimate bond between the layers of
dissimilar materials is desired in order to maximize the conductivity between the layers.
35 If required, the thickness of the composite foil may be readily controlled by
conventional rolling techniques.

1 More than one corrosion resistant layer or thickness may be used when it is
desired that the increase in corrosion penetration resistance occurs in a more gradual
manner after penetration of layer 22 by the electrolyte; see FIG. 4. Where an
5 additional layer of corrosion resistant material is used as with corrosion resistant layer
20 it is desired that this material be chosen from a class of materials that is both
corrosion resistant to a lesser extent than the initial (i.e., adjacent to core 18) corrosion
resistant layer 20 and participates in the electrochemical reaction to a greater extent
10 than the initial corrosion resistant layer. In the context of lead-acid batteries and the
related electrochemical reaction, a material comprising pure lead provides the degree
of electrochemical participation desired. The simultaneous corrosion resistant
characteristic may be acquired by using a lead alloy comprising a material that is both
chemically compatible with lead and corrosion resistant. Preferred materials for
15 constructing an additional corrosion resistant layer may comprise pure lead or a lead
alloy selected from the group consisting of lead-indium, lead-calcium, lead-tin, lead-
silver, lead- aluminum, and lead-antimony or any combination thereof. As with the
initial corrosion resistant layer 20, the same alloying agents may be added to the
chosen lead alloy in the same proportion in order to achieve a particular physical
property.

20 A particularly preferred material for constructing an additional corrosion
resistant layer 28 is lead-tin (PbSn) alloy. A preferred lead-tin alloy comprises in the
range of from 0.01 to 3 percent by weight tin and has a thickness in the range of from
0.04 to 0.2 millimeters. A particularly preferred additional corrosion resistant layer
28 comprises approximately 1 percent by weight tin and has a thickness of
25 approximately 0.08 millimeters. In order to achieve improved participation in the
electrochemical reaction an amount of antimony (Sb) in the range of from 0.2 to 15
percent by weight may be added to the lead alloy (i.e., lead-tin) or any combination
of alloys chosen for the additional corrosion resistant layer. A particularly preferred
additional corrosion resistant layer comprises approximately 1 percent by weight
antimony.

30 If plural corrosion resistant protective layers for the electrode structural core
are to be made from similar lead alloys, the property of decreasing corrosion resistance
can be achieved by gradually decreasing the proportion of alloying agent in the material
with each additional layer proceeding away from the core toward the side of the
electrode where corrosion occurs when the battery is operated in its discharge mode.
35 This explains why, in a preferred embodiment, the initial corrosion resistant layer
proximate the core member will comprise a greater proportion of alloying agent than
that contained in each subsequent corrosion resistant layer.

1 Each successive corrosion resistant layer may be joined to the surface of the precursor or previous corrosion resistant layer by using the same process as that used to affix layer 20 to core 18.

5 An electrode plate of the present invention may comprise as many corrosion resistant layers as desired to simultaneously achieve a more gradual increase in corrosion penetration resistance and decrease in electrochemical reactivity as one proceeds towards core member 18 from the layer of positive-side active material 14. This may be desirable where the electrode plate is to be used in a battery application requiring a high degree of reliability, such as with airplanes, satellites or space vehicles and the like. Each subsequent corrosion resistant layer can contain a progressively smaller proportion of the same alloying agent, such as tin in presently the practice of the invention, preferred embodiment, or different layers can contain different alloying agents in desired concentrations.

10 For example, an electrode plate may comprise a core member, a first corrosion resistant layer, a second corrosion resistant layer, a third corrosion resistant layer and a fourth corrosion resistant layer in succession proceeding from the electrode structural core member towards the positive active material. In such event, assuming that lead-tin is used as the basic alloy, each corrosion resistant layer will have a lesser proportion of alloying agent, i.e., tin, than that of the precursor or prior corrosion resistant layer.

15 With respect to the layer 22 of interface material capable of substantial participation in the electrochemical reaction with the positive-side active material 14, a material comprising lead provides the degree of electrochemical participation desired for use in a lead-acid battery. An additional requirement, however, is that the interface layer be capable of fusing with and forming an intimate interface with the positive active material used in a lead battery, namely lead dioxide (PbO_2). The ability of the interface layer to fuse with and form an intimate interface with the active material is important because the performance of a battery is largely dependant on the ability of the active material surface to both participate with the battery electrolyte in the electrochemical reaction and transfer electrons to the electrode core member. Optimal electron transfer (electrical conductivity) from the active material to the core member is realized when the active material is in intimate interface with the interface layer. Optimal participation of the active material in the electrochemical reaction is realized when the active material is in intimate interface with the interface layer, and thus capable of withstanding the chemical and electrochemical environment of a battery without falling away from the electrode plate.

20

25

30

35

1 Therefore, lead-alloys comprising a material capable of fusing and forming an
intimate interface with lead dioxide are preferred as the material for electrode layer 14.
Preferred materials for constructing the interface layer may comprise pure lead or a
5 lead alloy selected from the group consisting of lead-indium, lead-calcium, lead-tin,
lead-silver, lead-aluminum, and lead-antimony or any combination thereof. As with
the corrosion resistant layer 20, the same alloying agents may be added in the same
proportion to the lead alloy chosen to construct interface layer 22 in order to achieve
a particular physical property.

10 A particularly preferred interface material is lead-antimony (PbSb) alloy.
Antimony is the preferred alloying agent due to its ability to corrode while maintaining
an intimate interface with the lead dioxide positive-side active material. A preferred
lead-antimony alloy comprises in the range of from 0.2 to 15 percent by weight
antimony and has a thickness in the range of from 0.06 to 0.3 millimeters. An
15 interface layer comprising less than 0.2 percent by weight antimony will not exhibit the
degree of fusion with the active material desired in the construction of an electrode
plate. An interface layer comprising more than 15 percent by weight antimony will not
exhibit the desired degree of participation in the electrochemical reaction. A
particularly preferred interface layer comprises approximately 3 percent by weight
antimony and has a thickness of approximately 0.1 millimeters. In order to achieve
20 penetration corrosion resistance an amount of tin (Sn) in the range of from 0.01 to 5
percent by weight may be added to the lead alloy (i.e., lead-antimony) or any
combination of alloy chosen for the interface layer. A particularly preferred interface
layer comprises approximately 0.8 percent by weight tin.

25 The layer 22 of the interface material may be applied to the surface of the
adjacent corrosion resistant layer by a cladding process which is preferred for the
reasons already stated.

30 The positive-side active material 14 is chosen to participate substantially in the
electrochemical reaction desired on the positive or anodic side of the battery electrode
plate. For use in a lead-acid battery system, the preferred positive-side active material
comprises lead dioxide (PbO₂) paste. The positive-side active material may be applied
by conventional methods well known to those skilled in the art to the surface of the
interface layer 22.

35 With respect to the selection of the negative-side active material it is desired
that the material chosen participate substantially in the electrochemical reaction taking
place on the negative or cathodic side of the battery electrode plate. For use in a lead-
acid battery system the preferred negative-side active material comprises sponge lead.
As with the positive-side active material, the negative-side active material may be

1 applied by conventional methods to a protective layer 27 on the negative side of the
electrode core, the protective layer serving to protect the core material from attack by
the electrolyte by chemical and electrochemical processes. The negative side protective
layer can be pure lead or any desired lead alloy. Layer 27 preferably is affixed to the
5 core by a metal cladding process. Layer 27 can be relatively thin as it is not attacked
or corroded to any significant degree as the battery undergoes discharging and charging
processes.

Consistent with the foregoing, FIG. 4 illustrates a preferred embodiment of an
electrode plate 29. Electrode 29 comprises a core member 18 that serves as a
10 structurally rigid conductive member for the electrode plate. With respect to the
positive (anodic) side of the electrode plate to the right of the dashed line 15, a first
corrosion resistant layer 20 (e.g., lead-tin alloy comprising approximately 3 percent by
weight tin) is in intimate contact with the core member 18. A second corrosion
resistant layer 28 (e.g., lead-tin alloy comprising approximately 1 percent by weight
15 tin) of lesser corrosion resistant and more electrochemical active properties than
corrosion resistant layer 20 is in intimate surface contact with layer 20. An interface
material layer 22 (e.g., a lead-antimony alloy) having the capacity to both substantially
participate in the electrochemical reaction and fuse with or form an intimate interface
a the positive-side active material 14 is in intimate surface contact with the surface of
20 layer 28. A positive-side active material 14 (e.g., lead dioxide) forms the surface of
the positive side of the electrode plate and is in intimate interface with the surface of
material layer 22. At the negative (cathodic) side of the electrode plate to the left of
the dashed line, a negative-side active material layer 26 is in intimate surface contact
with the adjacent surface of a core protecting layer 27 which is in intimate surface
25 contact with structural core 18 over the whole of the negative side of the core.

Although corrosion resistant layers and an interface layer capable of both
substantial electrochemical participation and fusing with or forming an immediate
interface with the positive-side active material have been described above as separate
and distinct thicknesses of a multi-layered electrode construction, a single thickness of
30 material can be used to achieve the purposes and functions described above. For
example, instead of providing separate corrosion resistant and interface layers, an
electrode plate may be constructed in which a single layer of differentially alloyed lead
is present between a structural core sensitive to the battery electrolyte and the positive
active material.

35 FIG. 7 pertains to an example of a single layer 60 of material having at
different locations through its thickness, different degrees of the properties of corrosion
resistance, on the one hand, and participation in the electrochemical reaction and

1 intimate association and cooperation with the positive-side active material. The single
layer 60 comprises a lead-alloy having a decreasing proportion of alloying agent
resistant to penetration corrosion (tin in this example) and an increasing proportion of
5 alloying agent (antimony in this example) capable for forming an intimate interface
with the positive-side active material proceeding through the layer from a surface 61
engaged with a supporting surface of core member 18 at the left side of the layer to the
positive-side active material 14 at the right side of the layer. Thus, in FIG. 7 curve
62 is read with a % Sn scale 63 at the left side of FIG. 7 and curve 64 is read with a
10 % Sb scale 65 at the right side of the same Figure. This variation in alloy composition
yields the desirable simultaneous characteristics for the single thickness of decreasing
corrosion resistance, and of increasing participation in the electrochemical reaction and
increasing capability to fuse and form an intimate interface with the positive-side active
material the further a unit volume of the layer lies from structural core 18 to the
15 positive-side active material 14. Although layer 60 comprises varying mixtures of
lead-tin and lead-antimony, other materials in addition to or in substitution for those
alloying metals may be used to define a differentially alloyed layer having the desired
properties.

A differentially alloyed electrode layer, such as layer 60, can be defined by
applying the dopant (i.e., alloying metal) by diffusion processes with different dopant
20 materials to the opposite surfaces of a host metal (e.g., lead) layer of desired thickness.
The differentially alloyed layer then can be affixed to an electrode structural core
member to fully cover the core member surface by use of any suitable procedure or
process, a metal cladding process performed in a reducing environment being
preferred.

25 Workers skilled in the art and science of battery design and manufacture will
readily appreciate that an electrode construction according to the foregoing description
of electrode constructions 12 and 29, or of an electrode in supporting the differentially
alloyed electrode layer 60 represented in FIG. 7, has particular utility in a bipolar
battery. The electrode has exterior surfaces defined of materials which cooperate
30 efficiently and effectively with suitable positive and negative active materials so that
the desired galvanic processes can occur at the opposite sides of the electrode. The
core of the electrode can be defined by any suitable constructive material, preferably
a common metal, which is strong yet relatively light and which has other desired
properties such as compatibility with the processes used to reclaim and recycle the
35 materials used to manufacture the electrode in the first instance. The material of the
core member can be selected and defined principally in terms of the functions the core
member is to serve in the electrode without regard to how that material may react with

1 or be attacked by the electrolyte to be used with the finished electrode. The destructive and corrosive galvanic (electrochemical) processes of the battery occur at the positive side of the electrode, and the electrode can be defined to cause those processes to occur efficiently.

5 Further, workers skilled in that same art and science will understand the role played during the useful life of the electrode by the electrode layer intermediate the core member and the positive face of the electrode. That role is illustrated in the series of views of FIGs. 6(a) through 6(e) in the accompanying drawings. It is well known that the corrosive galvanic processes productive of electron release do not occur
10 truly uniformly across the surface between, for example, lead and lead dioxide in the presence of an electrolyte such as, for example, sulfuric acid; on a macroscopic level the corrosion process may be perceived to be uniform, but at a local or microscopic level that is not the case. The reason is that the metal or other conductive material which carries the battery positive active material is not truly homogeneous and
15 amorphous. It has local differences due to impurities, crystal structural, grain orientation and other factors, most of which are known and understood. As a consequence, the corrosive positive galvanic process occurs more actively and vigorously at some places along that electrode surface than at other places. The results is that pits develop at local sites on the active material surface and propagate through
20 the material defining that surface more rapidly than at other places in that material. Those local pitting phenomena are treated statistically, i.e., on average basis, in the design of a battery of given kind intended for a specific purpose or for general purpose use. That is, no storage battery relying on galvanic processes is permanent or life-
25 limitless; all such batteries have a design life expectancy and, like people, some live longer than others, but on average they have a defined life. Therefore, workers skilled in the art and science to which this invention pertains will appreciate that this invention exists within the context of that reality. That reality has more dire implications and consequences in a bipolar battery than in a monopolar battery. In a bipolar battery, the biplates are serially arranged, and the corrosive penetration of a biplate by the
30 battery electrolyte results in rapid failure of the pair of cells separated by that biplate. On the other hand, in a monopolar battery in which separate positive and negative electrodes are interdigitated within a given cell (and plural cells are serially connected to achieve a desired voltage), the corrosive penetration of a single positive electrode does not cause the cell to fail catastrophically but merely to suffer a gradual reduction
35 in performance, and such reduction in performance within a cell of a monopolar battery does not significantly burden other cells in the battery. In a bipolar battery, however, the catastrophic failure of a pair of cells by reason of electrolytic penetration of the

1 biplate between them causes the internal resistance of the battery to rise. That increase
in internal resistance sufficiently burdens other cells in the same battery that their
mortality rate rises. Thus, once one biplate in a bipolar battery fails, the degenerative
5 illness to which all galvanic battery are inherently subject shifts, in effect, to a higher
gear and the entire battery soon fails in a relatively short time. That overall failure,
if it occurs suddenly, could place the user of the battery at risk or at a significant
disadvantage. On the other hand, if a bipolar battery fails more gradually and
predictably, the user has time, more or less at his convenience, to replace the battery
10 and avoid that risk or inconvenience. This invention, for the reasons set forth alone,
assures that the failure of a bipolar battery, usually toward the end of its design life,
will occur gradually and predictably rather than suddenly.

 The several views of FIGs. 6(a) through 6(e) depict a localized area of a biplate
according to this invention at substantially regular intervals over the life of the biplate,
15 illustrating the difference in corrosion potential between the interface layer 22 and the
corrosion resistant layer 20.

 FIG. 6(a) shows a cross-sectional view of the biplate comprising a core
member 18, a corrosion resistant layer 20, an interface layer 22, and a positive-side
active material 14. FIG. 6(a) shows the biplate at a point in time when the interface
20 layer 22 has just begun to corrode and form lead dioxide (PbO_2) which combines with
the positive-side active material 14.

 FIG. 6(b) depicts the same area of the electrode plate at a point in time when
the interface layer has been substantially corroded. FIG. 6(c) depicts the same area of
the electrode plate after an equivalent interval of time, illustrating the through corrosion
25 of the interface layer such that positive-side active material 14 is extending to the
surface of the corrosion resistant layer 22. FIG. 6(d) depicts the same area of the
electrode plate after an equivalent interval of time, illustrating the initial corrosion of
the corrosion resistant layer. Like the interface layer, the corrosion product of the
corrosion resistant layer is lead dioxide which combines with the positive-side active
30 material layer 14.

 FIG. 6(d) shows the difference in corrosion potential between the corrosion
resistant layer and the interface layer. Specifically, the superior corrosion resistance
of the corrosion resistant layer is illustrated by it registering only a marginal degree of
corrosion loss when compared to the significant corrosion loss registered by the
interface layer the interface layer as measured from the time of FIG. 6(c).

35 FIG. 6(e) depicts the electrode plate after an equivalent interval of time, and
clearly illustrates the large difference in corrosion potential between the interface layer
22 and the corrosion resistant layer 20. Similar to FIG. 6(d), the superior corrosion

1 resistant properties of the corrosion resistant layer is shown by its marginal corrosion
loss when compared to the significant decrease in area registered by the interface layer
as measured from the time of FIG. 6(d).

5 As noted above, another problem long known to exist with storage batteries is
that of effectively sealing a conductive battery component to a battery housing at a
connection of the component to the housing so that electrolyte cannot leak through the
connection. That problem becomes acute in bipolar batteries where each biplate must
be sealed along its perimeter to other battery components to define a chamber on each
10 side of the biplate from which electrolyte cannot leak around the biplate to an adjacent
chamber or to the exterior of the battery. This invention addresses that problem in the
ways shown in FIGS. 8, 9 and 10.

15 An electrode plate 12, e.g., according to the present invention comprises a
protective coating along its perimeter edge and on the whole of a peripheral portion of
each opposite face of the plate as shown in FIG. 2. That coating covers deoxidized
areas on the surfaces and edges of the electrode plate. If the protective coating is to
be used to form an electrolyte seal about the peripheral portion of the electrode plate
the coating must be oxygen impermeable, chemically and electrochemically inert, and
be capable of interacting with a nonconductive battery member to form an electrolyte-
tight seal. The protective coating is applied to the edges and the peripheral margin of
20 both the positive and negative sides of the electrode plate preferably before the positive
and negative active materials are applied to the electrode plate, for the purpose of
eliminating electrolyte migration that can occur along a surface of a conductive member
of a battery, where the surface is corroded by the battery electrolyte, as the conductive
member extends through or to the battery's outside surface.

25 While not wishing to be bound to any particular theory, it is believed that the
migration of battery electrolyte across the surface of a conductive member is caused
two different corrosion mechanisms, creep corrosion and crevice or nodular corrosion.
These corrosion mechanisms are well known in the art and were the topic of a paper
entitled "Vulcanized Rubber Post Seal For Lead-Acid Batteries A New Generic Type"
30 presented at the 1988 Intelc International Telecommunications Energy Conference.
Both types of corrosion are believed to occur at the surface of the conductive member
which is connected to a nonconductive battery member or the housing of the battery.
This corrosion is believed to occur in the presence of an oxide film at the surface of
the conductive member, which film enables the development of porous microscopic
35 irregularities on the surface of the conductive member. It is believed that the presence
of these irregularities facilitates the migration of electrolyte along that surface, as by
capillary action through the oxide film itself and in other ways, and prevents the

1 formation of an electrolyte-tight seal by known methods other than by intimate
interaction of the conductive battery member and the nonconductive battery member
by extreme pressure.

5 This invention provides an electrolyte-tight seal without reliance upon the
application of extreme pressures to form a connection of biplate according to this
invention to an adjacent nonconductive component of a bipolar battery. It does so by
removing the oxide film from the surfaces of the biplate via which connection to other
battery components are to be made, and then coating the deoxidized surface with an
oxygen impermeable protective coating. One method of preparing a biplate 12 for
10 effective leak proof connection to another battery component, such as insulating frame
member 30 (see FIG. 5) is illustrated in FIGS. 8(a) through 8(e). FIGS. 8(a) through
8(e) are cross-sectional views of electrode plate 12 at an adjacent one edge of the plate.
FIG. 8(a) illustrates the electrode plate as manufactured before treatment to apply a
protective coating 42.

15 All metals oxidize when exposed to oxygen or to air which contains oxygen.
Depending on the metal, the oxide forms more or less rapidly and to varying thickness.
As a consequence, biplate electrode 12 necessarily will have a film of oxide on all
exposed surfaces when its manufacture, as described above, has been completed. That
oxide covering is depicted in FIG. 8 as oxide film 36. Some portions of that film are
20 desirable, notably those portions which cover the areas of the biplate which are to be
contacted by the battery active materials, notably the positive active material which,
in the case of biplate 12, is lead dioxide itself. However, in marginal areas 34 of the
plate surface, where the biplate is to be connected between a pair of insulating frames
30, that oxide film is very undesirable.

25 As shown in FIG. 8(b), the surfaces of the biplate where the presence of oxide
film 36 is not undesirable are coated with a masking layer, but areas 34 and the edges
of the biplate are not masked. The masking layer is formed of a material which is
inert to a reducing environment. Then, as depicted in FIG. 8(c), the masked biplate
is placed in a suitable reducing environment which is free of any and all forms of
30 oxygen which can react with the materials of the biplate to form oxides of those
materials. The reducing environment removes oxide film 36 from all areas of the
biplate which are not covered by masking material 38, thus to provide oxide free areas
40 at the plate margins and edges.

35 Next, while the biplate continues to be in a reducing or oxygen-free
environment, a layer of an oxygen impermeable material, that is both chemically and
electrochemically stable and capable of joining with the battery housing or
nonconductive battery member to form an electrolyte-tight seal, is applied to areas 40

1 and to the biplate edges to form on those areas and edges a coating 16 which protects
those deoxidized surfaces from contact by oxygen or by compounds containing oxygen
in a form capable of reacting with the biplate materials to form oxides of them.
Thereafter, as shown in FIG. 8(e), masking material 38 is removed from the surfaces
5 of the biplate inside now-protected areas 40 to expose those surfaces.

The method step of removing oxide film 36 can be achieved by using well
known commercial processes such as immersing the electrode plate in a chemical
reducing agent. The coating step (FIG. 8(d)) preferably is performed in a non-
oxidizing atmosphere such as in a vacuum or in a nitrogen atmosphere in order to
10 prevent the reformation of an oxide film on the unmasked electrode plate surfaces.
The elimination of oxides from the sealing areas of the electrode plate is important to
prevent electrolyte migration across the plate surface caused by the phenomenon of
nodular crevice corrosion, and thus provide an electrolyte-tight seal.

Protective coating 16 can be formed of any suitable material that forms an
15 oxygen barrier, is chemically and electrochemically stable, is electrically nonconductive
and capable of joining with the battery housing or nonconductive battery member to
form an electrolyte-tight seal. Preferred protective coating materials may include
lacquers, polymers, rubbers, plastics, silicones, adhesives, rubber cements and the like,
provided they are compatible with the further processes to which the electrode plate is
20 subjected in the further manufacture of battery 10. The coating material can be a
material, such as a heat activatable adhesive, which participates directly in the
definition of the seal or connection ultimately desired.

Although the method of accomplishing an electrolyte-tight seal between a
conductive battery member and another battery member has been described in reference
25 to an electrode plate used to construct a bipolar battery, this method applies to
conventional monopolar batteries as well. For example, the method of this invention
may be applied to accomplish a electrolyte-tight seal between a battery terminal and a
battery housing of a conventional monopolar lead acid battery. FIG. 9 illustrates a
battery terminal 44 and its interconnection to a battery housing 46 as it passes from a
30 position within the battery, where it is in intimate contact with the battery electrolyte,
to a position outside the battery. At least a portion of the outer surface of terminal 44
which lies within a desired seal zone between itself and the battery housing is
circumferentially deoxidized and protectively coated, as at 45, in the manner described
above. After assembly of the battery housing cover to the battery housing, an annular
35 space between the terminal and an aperture 47 in the housing cover can be filled with
a suitable sealant 48 to create a seal which is secure against leakage of the electrolyte.

1 It has been found that certain alloys of lead, for example, develop oxide
coatings which are difficult to remove by chemical reduction, reducing atmospheres or
abrasion in oxygen-free atmospheres. One such alloy is lead-antimony alloy. In that
instance, it is the tightness of the bond of the surface oxide film to the underlying alloy
5 which makes such an alloy useful on the positive surface of a battery electrode; that
oxide layer facilitates the desired intimate contact and cooperation with lead dioxide as
a battery positive active material. If the instance of lead-antimony alloys, and also
other alloys which develop tightly bound oxide films, the oxide film can be removed
by the use of a flux. Therefore, with reference to FIG. 10, a presently preferred
10 procedure for preparing edge margins of an electrode biplate 62 having a surface layer
63 of lead-antimony alloy is to apply a layer 64 of lead-alloy solder (i.e., 50/50 lead-
tin) to the margin of that surface in the presence of a flux, preferably a rosin-type flux.
The solder can be applied in air. As the solder is applied, the flux removes the topical
oxide layer from the lead-antimony and the solder immediately wets and covers the
15 oxide free surface. As the solder solidifies on the biplate margin, it develops its own
oxide coating, but that oxide layer is readily removed in the ways described above,
e.g., by application of a reducing atmosphere to enable coating 16 to be applied to bare
metal at the biplate margin and edges.

 In certain instances it may be desirable to form a temporary oxygen
20 impermeable coating on the surface of a conductive metal used in battery construction.
Such a temporary oxygen barrier may be formed by applying a rosin flux to the surface
area of the conductive member to be protected. The flux acts to remove the topical
oxide layer and forms an oxide impermeable coating over the newly deoxidized
surface. This protective coating is temporary in nature because the flux is neither
25 chemically nor electrically stable. Accordingly, before the conductive member is used
in the construction of a battery the temporary coating is removed by known methods
and substituted with a permanent coating that is oxygen impermeable, chemically and
electrochemically stable, and capable of interacting with the battery housing or
nonconductive battery member to form an electrolyte-tight seal.

30 The method of obtaining an electrolyte-tight seal according to this invention is
not limited to the construction of bipolar, monopolar, or even lead-acid batteries. It
is useful to eliminate the migration of battery electrolyte that may occur along or
around a conductive battery member that extends to or through the outside surface of
the battery or which lies wholly within the battery and is to be sealed to an adjacent
35 insulative battery component.

 FIG. 5 illustrates the relationship and cooperation of an electrode plate
according to this invention with other battery components used in the construction of

1 bipolar battery 10. Three electrode plates 12 are arranged in serial fashion. A
nonconductive frame-like insulating member 30 carrying a separating member 32 is
interposed between each adjacent pair of electrode plates. In constructing the battery,
the electrode plates and the insulating members are sandwiched together in intimate
5 contact with each other at their margins where they can be bonded together by a
suitable adhesive. The adhesive is applied to the deoxidized and protectively covered
marginal surface of the electrode plate.

When the battery components are so sandwiched together, the outside edges of
the electrode plates and the insulating members cooperate to define the outside surfaces
10 of bipolar battery 10. Accordingly, since each bipolar cell contains electrolyte and
each electrode plate is in intimate contact with the electrolyte, it is necessary that the
joint between each electrode plate and the adjacent insulating members be electrolyte
tight. To accomplish this, the electrode plates 12 each comprise a protective coating
16 that covers the edge and periphery of the electrode plate in a manner that overlaps
15 and mates with the adjoining surface area of each insulating member 30.

Separating members 32 are used in the construction of bipolar battery 10 to
ensure that each biplate is physically separated from and does not contact an adjoining
biplate. As illustrated in FIG. 5, the separating member may be configured to fit
within the inside perimeter of each insulating member 30. The main requirement for
20 a separating member is that it be nonconductive to electricity and permit ion transfer
to occur through it between adjoining biplates.

EXAMPLE OF THE PREFERRED EMBODIMENT

25 An electrode plate was constructed according to the practice of this invention
having a core member made from iron. The core member was configured in the shape
of a flat rectangular sheet having a thickness of approximately 0.4 millimeters. A first
corrosion resistant layer having a thickness of approximately 0.8 millimeters and
comprising approximately 96.7 percent by weight lead, 3 percent by weight tin, and
0.3 percent by weight silver was joined to one surface of the core member by a
30 commercial cladding process. A second corrosion resistant layer having the same
thickness of the first corrosion resistant layer and comprising approximately 98 percent
by weight lead, 1 percent by weight tin, and 1 percent by weight antimony was applied
to the surface of the first corrosion resistant member by the same cladding process used
to apply the first corrosion resistant layer.

35 A layer of interface material having a thickness of approximately 0.13
millimeters and comprising approximately 96.2 percent by weight lead, 3 percent by
weight antimony, and 0.8 percent by weight tin was applied to the surface of the

1 second corrosion resistant layer by the same cladding process used to apply the
corrosion resistant layers. A layer of positive-side active material comprising lead
dioxide was applied using conventional methods known in the art to the surface of the
interface material.

5 A thin pure lead foil having a thickness of approximately 0.1 millimeters was
applied to the surface of the core member opposite the positive-side active material by
commercial cladding process. A layer of negative-side active material comprising
sponge lead was applied using conventional means known in the art.

10 The foregoing description of presently preferred and other aspects of this
invention has been presented by way of illustration and example. It does not present,
nor is it intended to present, an exhaustive catalog of all structural and procedural
forms by which the invention can be embodied. Variations upon and alterations of the
described structure and procedure can be pursued without departing from the fair
substance and scope of the invention consistent with the foregoing descriptions and the
15 following claims which are to be read and interpreted liberally in the context of the
state of the art from which this invention has advanced.

20

25

30

35

1 **WHAT IS CLAIMED IS:**

5 1. An electrode for an electrochemical battery in which the electrode is to participate with an electrolyte in a desired electrochemical reaction, the electrode comprising;

 a structural electrode core member;

 a conductive interface material for contact by and corrosive participation with a positive active material in the desired electrochemical reaction in the presence of the electrolyte;

10 a conductive protective material interposed between the electrode core member and the interface material that resists corrosion to a greater extent than the interface material, participates in the desired electrochemical reaction less actively than the interface material and can form an intimate relation with the positive active material.

15 2. The electrode as recited in claim 1 wherein the protective material comprises at least one corrosion resistant layer, the corrosion resistant layer being in intimate contact on one side thereof with a surface of the core member, and in intimate contact with the interface material on an opposite side thereof.

20 3. The electrode as recited in claim 2 wherein the protective material comprises a plurality of discrete corrosion resistant layers, each successive layer being in intimate surface contact with a previous layer, the plurality of layers being disposed between the core member and the interface material, each successive layer having the properties of resisting corrosion to a lesser extent than and participating in the desired electrochemical reaction to a greater extent than the layer adjacent to it toward the electrode core member.

25 4. The electrode as recited in claim 1 wherein the interface and protective materials are comprised by a single thickness of a material that is in intimate surface contact with the core member on one side thereof and is engagable by a positive active material on an opposite side thereof, the material of the single thickness exhibiting differentially through it the properties of corrosion resistance, electrochemical participation, and the capacity to intimately engage the positive active material to different degrees at different locations from the electrode core member.

30 5. The electrode as recited in claim 4 wherein the material of the single thickness exhibits decreasing corrosion resistance and increasing participation in the

35

1 electrochemical reaction progressing through the thickness from the electrode core member.

5 6. An electrode for an electrochemical battery in which the electrode is to participate with an electrolyte in a desired electrochemical reaction, the electrode comprising;

a structural electrode core member;

10 a conductive interface material for contact by and corrosive participation with a positive active material in the desired electrochemical reaction in the presence of the electrolyte;

a conductive intermediate body interposed between the electrode core member and the interface material that resists corrosion to a greater extent than the interface material, participates in the desired electrochemical reaction less actively than the interface material and can form an intimate relation with the positive active material.

15 7. An electrode for an electrochemical battery in which the electrode is to participate with an electrolyte in a desired electrochemical reaction, the electrode comprising;

an electrode core member;

20 a conductive corrosion resistant body in intimate contact on one side thereof with a surface of the core member;

25 a conductive interface body in intimate contact with an opposite side of the corrosion resistant body, the interface body being comprised of a material which is both capable of substantial participation with the electrolyte in the electrochemical reaction and of forming an intimate relation with a positive-side active material applied to it; and

a conductive negative-side active material carrier in intimate contact with a surface of the core member opposite the corrosion resistant body.

30 8. The electrode as recited in claim 7 wherein the core member comprises a material that is both structurally rigid and electrically conductive.

35 9. The electrode as recited in claim 8 wherein the corrosion resistant body comprises a material having the simultaneous properties of being corrosion resistant and participating in the electrochemical reaction, the interrelationship of these properties varying inversely between the sides of the resistant body as a function of distance in the body from the core member.

1 10. The electrode as recited in claim 7 wherein an additional corrosion
resistant body is in intimate contact with and disposed between the corrosion resistant
body and the interface body, the additional corrosion resistant body comprising a
5 material that is corrosion resistant to a lesser extent than the first corrosion resistant
body and participates in the electrochemical reaction to a greater extent than the first
corrosion resistant body.

10 11. The electrode as recited in claim 10 wherein the material of the first
corrosion resistant body is selected from the group of lead and alloys of lead wherein
the alloy materials are selected from the group consisting of tin, indium, calcium,
aluminum, antimony, and silver.

15 12. The electrode as recited in claim 11 wherein the material of the
additional corrosion resistant body is selected from the group of lead and alloys of lead
wherein the alloy materials are selected from the group consisting of tin, indium,
calcium, aluminum, antimony, and silver.

20 13. The electrode as recited in claim 11 wherein the first corrosion resistant
body is lead-tin alloy comprising in the range of from 0.01 to 5 percent by weight tin.

25 14. The electrode as recited in claim 13 wherein the additional corrosion
resistant body is lead-tin alloy comprising in the range of from 0.01 to 3 percent by
weight tin.

30 15. The electrode as recited in claim 7 wherein the interface body is lead
alloyed with antimony.

35 16. The electrode as recited in claim 7 wherein the carrier is lead.

 17. The electrode as recited in claim 7 wherein the material of the core
member is selected from a group consisting of carbon steel, copper, aluminum, iron,
stainless steel, graphite prepreg, ceramics, metal epoxies, metal polyolefins, metal
thermoplastics, metal thermosets, metal polycarbonates, and polymer composites with
conductive additives of SnO₂, Ti₄O₇.

1 18. An electrode plate for an electrical battery in which the electrode is to participate with an electrolyte in a desired electrochemical reaction, the electrode plate comprising;

 an electrode core member that is structurally rigid and electrically conductive;

5 at least one corrosion resistant layer comprised of a material that resists corrosion by the electrolyte and participates in the desired electrochemical reaction in the presence of the electrolyte, the corrosion resistant layer intimately engaging with a surface of the core member;

10 a layer of interface material capable of substantial participation in the desired electrochemical reaction in the presence of the electrolyte, the interface layer comprising lead-antimony alloy and intimately engaging with a surface of the corrosion resistant layer;

15 a positive-side active material capable of substantial participation in the desired electrochemical reaction, the positive-side active material being lead dioxide in intimate contact with the interface layer; and

 a negative-side active material capable of substantial participation in the desired electrochemical reaction, the negative-side active material being sponge lead in intimate conductive relation to the surface of the core member opposite the positive-side active material.

20 19. The electrode as recited in claim 18 wherein the electrode comprises first and second corrosion resistant layers comprised of material selected from the group of lead and alloys of lead wherein the alloy materials are selected from the group consisting of tin, indium, calcium, aluminum, antimony, and silver, the first corrosion resistant layer being in intimate contact on one side thereof with a surface of the electrode core member and interposed between the core member and the second corrosion resistant layer, the second corrosion resistant layer being in intimate contact with an opposite of the first corrosion resistant layer and interposed between the first corrosion resistant layer and the interface layer.

30 20. The electrode as recited in claim 19 wherein the first and second corrosion resistant layers are lead-tin alloy, the first corrosion resistant layer comprising in the range of from 0.01 to 5 percent by weight tin, the second corrosion layer comprising in the range of from 0.01 to 3 percent by weight tin.

1 21. The electrode as recited in claim 20 wherein the first corrosion resistant layer comprises approximately 3 percent by weight tin and the second corrosion resistant layer comprises approximately 1 percent by weight tin.

5 22. The electrode as recited in claim 21 wherein the interface layer is lead including in the range of from 0.2 to 15 percent by weight antimony.

 23. The electrode as recited in claim 22 wherein the interface layer comprises approximately 1 percent by weight antimony.

10 24. A method for making an electrode for an electrolytic storage battery which uses a selected electrolyte to produce a desired electrochemical reaction with the electrode, the method comprising the step of conductively interposing between a conductive electrode structural core member and a conductive body of material which participates actively with the electrolyte in the desired reaction an intermediate quantity of a conductive material which participates less actively with the electrolyte in the desired reaction.

15 25. A method for preparing, for leak-resistant sealing to a selected component of a housing of an electrolytic storage battery, a conductive member which is to extend from a position within the battery in intimate contact with a battery electrolyte into a seal zone with a nonconductive component of the battery, the method comprising the steps of;

20 deoxidizing at least a selected area of an external surface of the conductive member which lies within the seal zone;

25 coating the deoxidized area of the member with a material which adheres securely to the member and which is impervious to the passage of oxygen therethrough; and

30 performing the deoxidizing and coating steps in an environment free of oxygen in a form which can produce an oxide layer at the surface of the conductive member.

35 26. The method as recited in claim 25 wherein the steps of selectively deoxidizing and coating the deoxidized area of the conductive member are accomplished by masking the portion of the conductive surface that lies outside the seal zone.

1 27. The method as recited in claim 26 wherein the coating material is selected from the group consisting of lacquers, polymers, rubbers, plastics, silicones, adhesives and rubber cements.

5 28. The method as recited in claim 27 wherein a leak resistant seal is established between the conductive member and an interfacing battery member via the coated area of the conductive member.

10 29. The method according to claim 25 wherein removing oxides from at least the selected area of the conductive member by applying a solder thereto in the presence of a flux thereby to form over said area a layer of solder which makes metal-to-metal contact with the conductive member, and performing the deoxidizing and coating steps on the solder layer.

15 30. The method according to claim 25 wherein removing oxides from at least the selected area of the conductive member by applying a flux thereby to form over said area a layer of flux which serves to deoxidize the conductive member surface and forms an oxide impermeable coating over the deoxidized surface.

20 31. A method for achieving an electrolyte-tight seal in a lead-acid storage battery about conductive battery members in intimate contact with the battery electrolyte that extend through the body of the battery to its outside surface, the method comprising the steps of;

25 deoxidizing a selected surface area of a conductive battery member that lies within a seal zone by contacting the member by a reducing agent;

 washing and drying the surface area of the deoxidized conductive battery member;

 applying a protective coating to the portion of the deoxidized surface of the conductive member surface that lies within the seal zone;

30 performing the deoxidizing, washing and applying steps in an environment free of oxygen in a form which can produce an oxide layer on the member; and

 assembling the battery in such a manner that the portion of the conductive battery member carrying the protective coating is placed in direct contact with a non-oxidizable battery component defining the seal zone.

35 32. An electrode unit for a bipolar electric storage battery, the unit having opposite metallic surfaces, and characterized in that the unit surfaces have peripheral

1 margins which are free of oxides and are coated with a material which is impervious
to the passage of oxygen therethrough.

5 33. An electrode unit according to claim 32 wherein the material used to
coat the metallic surfaces is chemically stable, electrochemically stable, and is capable
of interacting with a battery housing or a nonconductive battery member for the
purpose of forming an electrolyte-tight seal.

10 34. An electrode unit according to claim 33 wherein one of the metallic
surfaces is defined by a lead-antimony alloy, the peripheral margins of that surface
carry a layer of lead-tin solder, which layer is oxide free on its side opposite from that
surface and is coated by the material which is imperious to the passage of oxygen
through it.

15

20

25

30

35

AMENDED CLAIMS

[received by the International Bureau on 24 January 1994 (24.01.94);
original claims 1,6,7,16,29,30 amended; remaining claims unchanged (7 pages)]

1. An electrode for an electrochemical battery in which the electrode is to participate with an electrolyte in a desired electrochemical reaction, the electrode comprising;

a structural electrode core member;

a conductive interface material for contact by and corrosive participation with a positive active material in the desired electrochemical reaction in the presence of the electrolyte;

a conductive protective material interposed between the electrode core member and the interface material that resists corrosion to a greater extent than the interface material, participates in the desired electrochemical reaction less actively than the interface material and can form an intimate relation with the positive active material.

2. The electrode as recited in claim 1 wherein the protective material comprises at least one corrosion resistant layer, the corrosion resistant layer being in intimate contact on one side thereof with a surface of the core member, and in intimate contact with the interface material on an opposite side thereof.

3. The electrode as recited in claim 2 wherein the protective material comprises a plurality of discrete corrosion resistant layers, each successive layer being in intimate surface contact with a previous layer, the plurality of layers being disposed between the core member and the interface material, each successive layer having the properties of resisting corrosion to a lesser extent than and participating in the desired electrochemical reaction to a greater extent than the layer adjacent to it toward the electrode core member.

4. The electrode as recited in claim 1 wherein the interface and protective materials are comprised by a single thickness of a material that is in intimate surface contact with the core member on one side thereof and is engagable by a positive active material on an opposite side thereof, the material of the single thickness exhibiting differentially through it the properties of corrosion resistance, electrochemical participation, and the capacity to intimately engage the positive active material to different degrees at different locations from the electrode core member.

1 5. The electrode as recited in claim 4 wherein the material of the single
thickness exhibits decreasing corrosion resistance and increasing participation in the
electrochemical reaction progressing through the thickness from the electrode core
member.

5 6. An electrode for an electrochemical battery in which the electrode is
to participate with an electrolyte in a desired electrochemical reaction, the electrode
comprising;

10 a structural electrode core member formed by a material which is conductive
and readily corrodible by the electrolyte;

 a conductive interface material for contact by and corrosive participation with
a positive active material in the desired electrochemical reaction in the presence of the
electrolyte;

15 a conductive intermediate body interposed between the electrode core member
and the interface material and which resists corrosion to a greater extent than the
interface material, which participates in the desired electrochemical reaction less
actively than the interface material and which can form an intimate relation with the
positive active material.

20 7. An electrode for an electrochemical battery in which the electrode is
to participate with an electrolyte in a desired electrochemical reaction, the electrode
comprising;

 a conductive electrode core member;

25 a conductive corrosion resistant body in intimate contact on one side thereof
with a surface of the core member;

30 a conductive interface body in intimate contact with an opposite side of the
corrosion resistant body, the interface body being comprised of a material which is
both capable of substantial participation with the electrolyte in the electrochemical
reaction and of forming an intimate relation with a positive-side active material applied
to it;

 the corrosion resistant body being defined of a material which can participate
in the electrochemical reaction with the electrolyte at a lower level of activity than the
interface body; and

35 a conductive negative-side active material carrier in intimate contact with a
surface of the core member opposite the corrosion resistant body.

1 8. The electrode as recited in claim 7 wherein the core member comprises
a material that is both structurally rigid and electrically conductive.

5 9. The electrode as recited in claim 8 wherein the
corrosion resistant body comprises a material having the simultaneous properties of
being corrosion resistant and participating in the electrochemical reaction, the
interrelationship of these properties varying inversely between the sides of the resistant
body as a function of distance in the body from the core member.

10 10. The electrode as recited in claim 7 wherein an additional corrosion
resistant body is in intimate contact with and disposed between the corrosion resistant
body and the interface body, the additional corrosion resistant body comprising a
material that is corrosion resistant to a lesser extent than the first corrosion resistant
body and participates in the electrochemical reaction to a greater extent than the first
15 corrosion resistant body.

20 11. The electrode as recited in claim 10 wherein the material of the first
corrosion resistant body is selected from the group of lead and alloys of lead wherein
the alloy materials are selected from the group consisting of tin, indium, calcium,
aluminum, antimony, and silver.

25 12. The electrode as recited in claim 11 wherein the material of the
additional corrosion resistant body is selected from the group of lead and alloys of lead
wherein the alloy materials are selected from the group consisting of tin, indium,
calcium, aluminum, antimony, and silver.

30 13. The electrode as recited in claim 11 wherein the first corrosion resistant
body is lead-tin alloy comprising in the range of from 0.01 to 5 percent by weight tin.

35 14. The electrode as recited in claim 13 wherein the additional corrosion
resistant body is lead-tin alloy comprising in the range of from 0.01 to 3 percent by
weight tin.

 15. The electrode as recited in claim 7 wherein the interface body is lead
alloyed with antimony.

1 16. The electrode as recited in claim 7 wherein the negative-side active material carrier is lead.

5 17. The electrode as recited in claim 7 wherein the material of the core member is selected from a group consisting of carbon steel, copper, aluminum, iron, stainless steel, graphite prepreg, ceramics, metal epoxies, metal polyolefins, metal thermoplastics, metal thermosets, metal polycarbonates, and polymer composites with conductive additives of SnO₂, Ti₄O₇.

10 18. An electrode plate for an electrical battery in which the electrode is to participate with an electrolyte in a desired electrochemical reaction, the electrode plate comprising:

 an electrode core member that is structurally rigid and electrically conductive;

15 at least one corrosion resistant layer comprised of a material that resists corrosion by the electrolyte and participates in the desired electrochemical reaction in the presence of the electrolyte, the corrosion resistant layer intimately engaging with a surface of the core member;

20 a layer of interface material capable of substantial participation in the desired electrochemical reaction in the presence of the electrolyte, the interface layer comprising lead-antimony alloy and intimately engaging with a surface of the corrosion resistant layer;

 a positive-side active material capable of substantial participation in the desired electrochemical reaction, the positive-side active material being lead dioxide in intimate contact with the interface layer; and

25 a negative-side active material capable of substantial participation in the desired electrochemical reaction, the negative-side active material being sponge lead in intimate conductive relation to the surface of the core member opposite the positive-side active material.

30 19. The electrode as recited in claim 18 wherein the electrode comprises first and second corrosion resistant layers comprised of material selected from the group of lead and alloys of lead wherein the alloy materials are selected from the group consisting of tin, indium, calcium, aluminum, antimony, and silver, the first corrosion resistant layer being in intimate contact on one side thereof with a surface of the electrode core member and interposed between the core member and the second corrosion resistant layer, the second corrosion resistant layer being in intimate contact

35

1 with an opposite of the first corrosion resistant layer and interposed between the first
corrosion resistant layer and the interface layer.

5 20. The electrode as recited in claim 19 wherein the first and second
corrosion resistant layers are lead-tin alloy, the first corrosion resistant layer
comprising in the range of from 0.01 to 5 percent by weight tin, the second corrosion
layer comprising in the range of from 0.01 to 3 percent by weight tin.

10 21. The electrode as recited in claim 20 wherein the first corrosion resistant
layer comprises approximately 3 percent by weight tin and the second corrosion
resistant layer comprises approximately 1 percent by weight tin.

15 22. The electrode as recited in claim 21 wherein the interface layer is lead
including in the range of from 0.2 to 15 percent by weight antimony.

23. The electrode as recited in claim 22 wherein the interface layer
comprises approximately 1 percent by weight antimony.

20 24. A method for making an electrode for an electrolytic storage battery
which uses a selected electrolyte to produce a desired electrochemical reaction with the
electrode, the method comprising the step of conductively interposing between a
conductive electrode structural core member and a conductive body of material which
participates actively with the electrolyte in the desired reaction an intermediate quantity
of a conductive material which participates less actively with the electrolyte in the
25 desired reaction.

30 25. A method for preparing, for leak-resistant sealing to a selected
component of a housing of an electrolytic storage battery, a conductive member which
is to extend from a position within the battery in intimate contact with a battery
electrolyte into a seal zone with a nonconductive component of the battery, the method
comprising the steps of;

deoxidizing at least a selected area of an external surface of the conductive
member which lies within the seal zone;

35 coating the deoxidized area of the member with a material which adheres
securely to the member and which is impervious to the passage of oxygen
therethrough; and

1 performing the deoxidizing and coating steps in an environment free of oxygen
in a form which can produce an oxide layer at the surface of the conductive member.

5 26. The method as recited in claim 25 wherein the steps of selectively
deoxidizing and coating the deoxidized area of the conductive member are
accomplished by masking the portion of the conductive surface that lies outside the seal
zone.

10 27. The method as recited in claim 26 wherein the coating material is
selected from the group consisting of lacquers, polymers, rubbers, plastics, silicones,
adhesives and rubber cements.

15 28. The method as recited in claim 27 wherein a leak resistant seal is
established between the conductive member and an interfacing battery member via the
coated area of the conductive member.

20 29. The method according to claim 25 wherein removing oxides from at
least the selected area of the conductive member includes applying a solder thereto in
the presence of a flux thereby to form over said area a layer of solder which makes
metal-to-metal contact with the conductive member, and performing the deoxidizing
and coating steps on the solder layer.

25 30. The method according to claim 25 wherein removing oxides from at
least the selected area of the conductive member includes applying a flux thereby to
form over said area a layer of flux which serves to deoxidize the conductive member
surface and forms an oxide impermeable coating over the deoxidized surface.

30 31. A method for achieving an electrolyte-tight seal in a lead-acid storage
battery about conductive battery members in intimate contact with the battery
electrolyte that extend through the body of the battery to its outside surface, the method
comprising the steps of;

deoxidizing a selected surface area of a conductive battery member that lies
within a seal zone by contacting the member by a reducing agent;

35 washing and drying the surface area of the deoxidized conductive battery
member;

applying a protective coating to the portion of the deoxidized surface of the
conductive member surface that lies within the seal zone;

1 performing the deoxidizing, washing and applying steps in an environment free
of oxygen in a form which can produce an oxide layer on the member; and
assembling the battery in such a manner that the portion of the conductive
battery member carrying the protective coating is placed in direct contact with a non-
5 oxidizable battery component defining the seal zone.

32. An electrode unit for a bipolar electric storage battery, the unit having
opposite metallic surfaces, and characterized in that the unit surfaces have peripheral
margins which are free of oxides and are coated with a material which is impervious
10 to the passage of oxygen therethrough.

33. An electrode unit according to claim 32 wherein the material used to
coat the metallic surfaces is chemically stable, electrochemically stable, and is capable
of interacting with a battery housing or a nonconductive battery member for the
15 purpose of forming an electrolyte-tight seal.

34. An electrode unit according to claim 33 wherein one of the metallic
surfaces is defined by a lead-antimony alloy, the peripheral margins of that surface
carry a layer of lead-tin solder, which layer is oxide free on its side opposite from that
20 surface and is coated by the material which is imperious to the passage of oxygen
through it.

FIG. 1

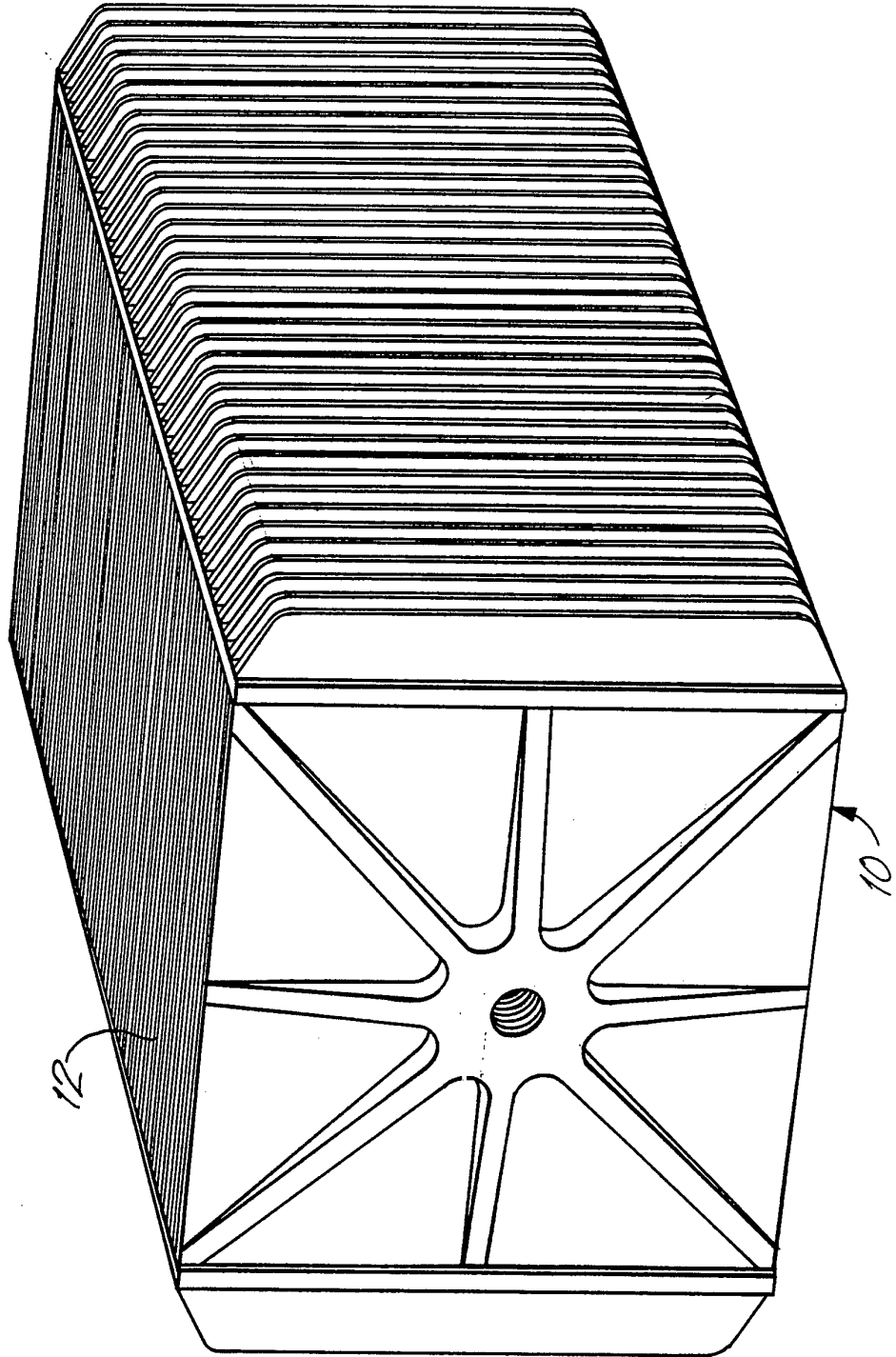

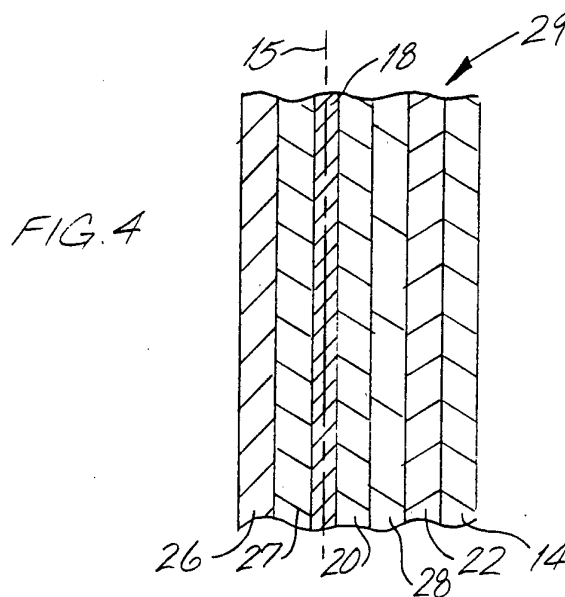
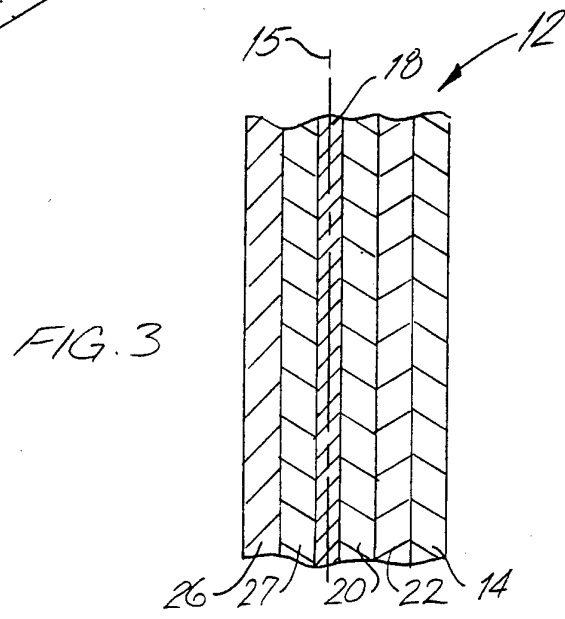
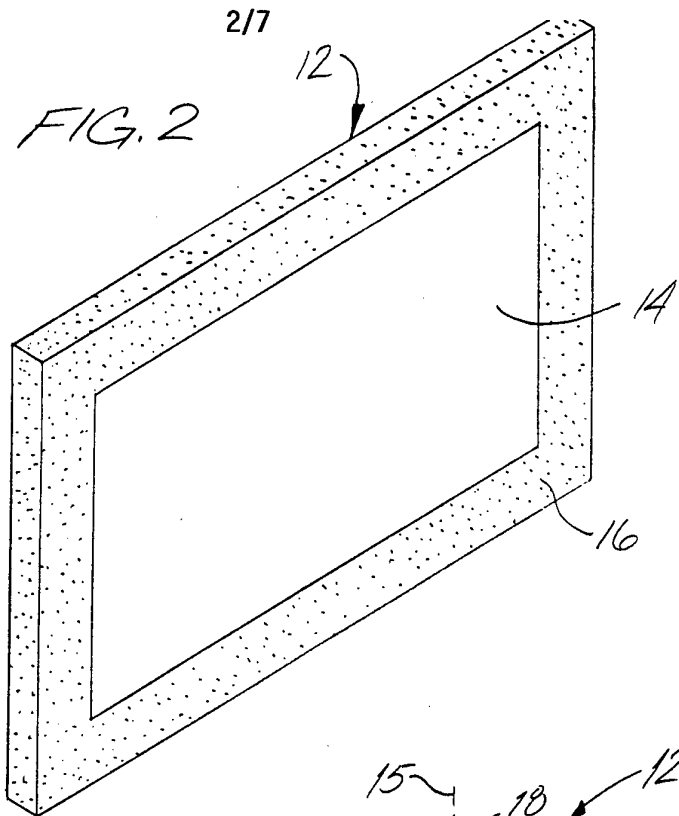

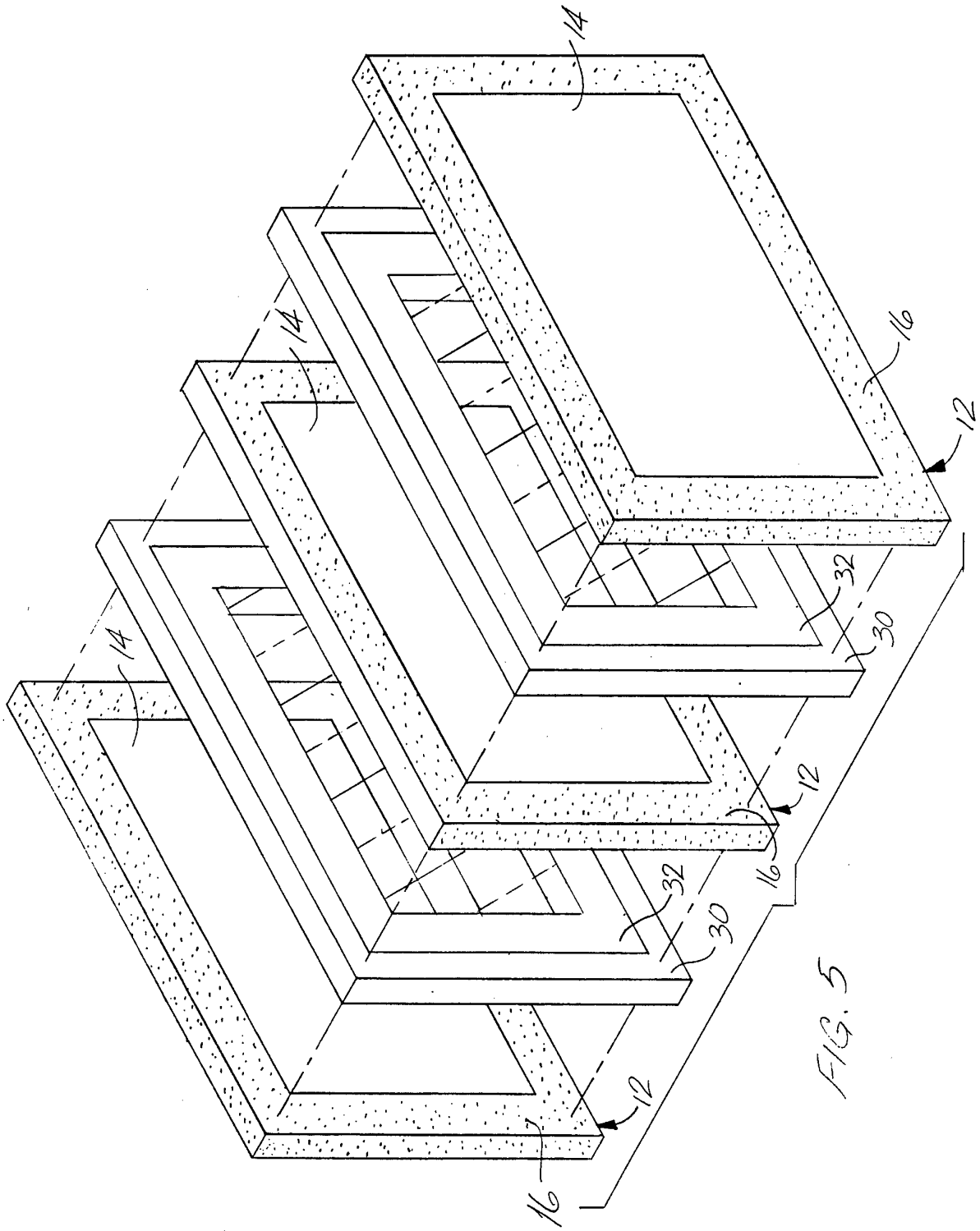
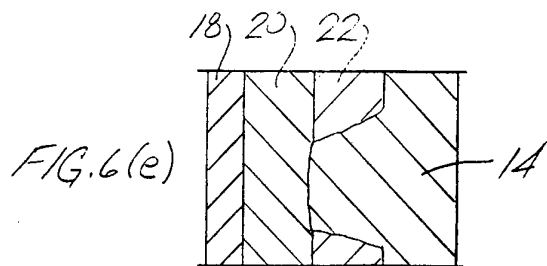
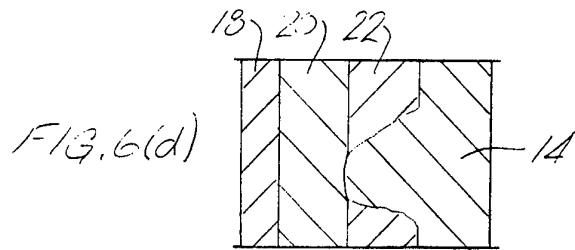
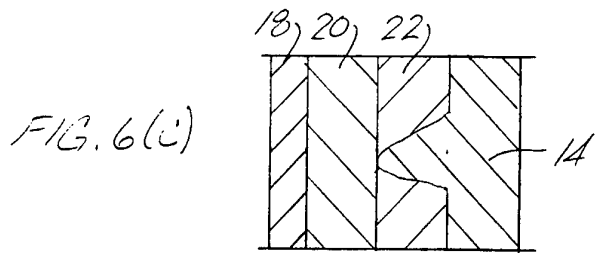
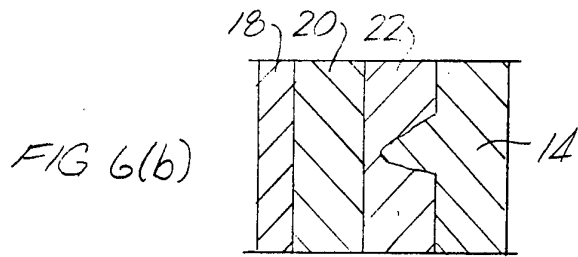
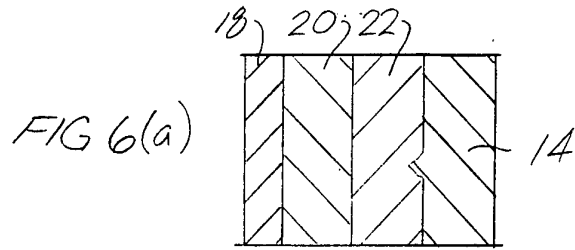

FIG. 5



5/7

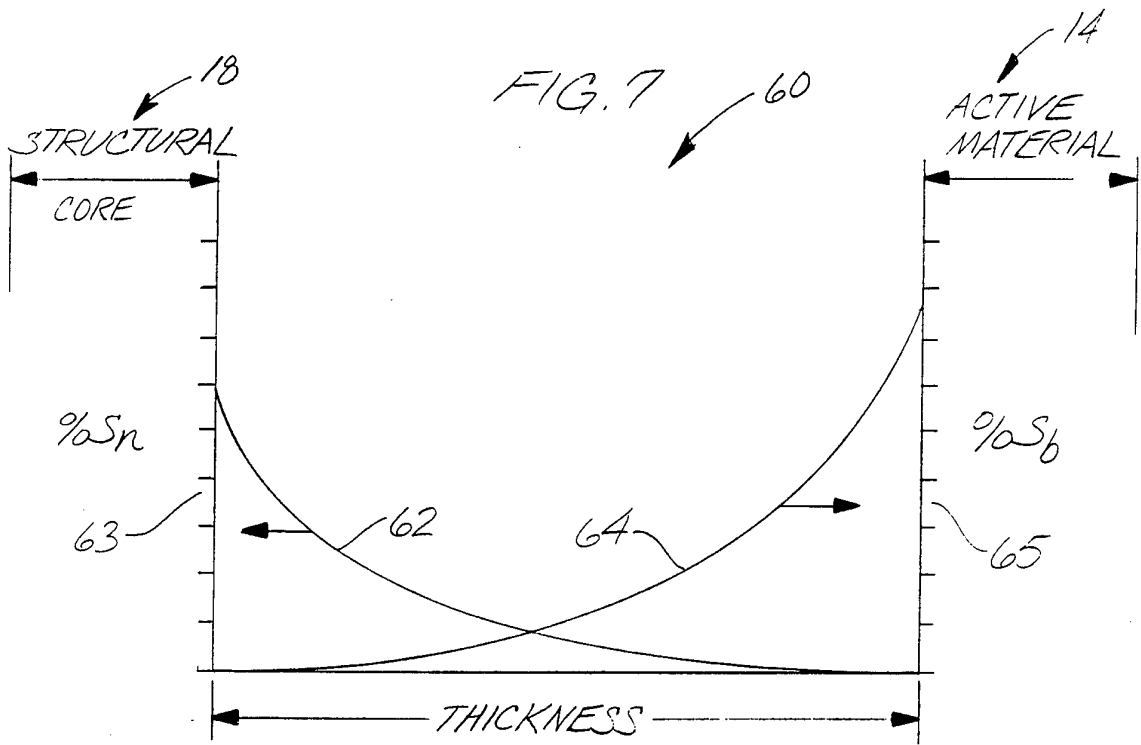
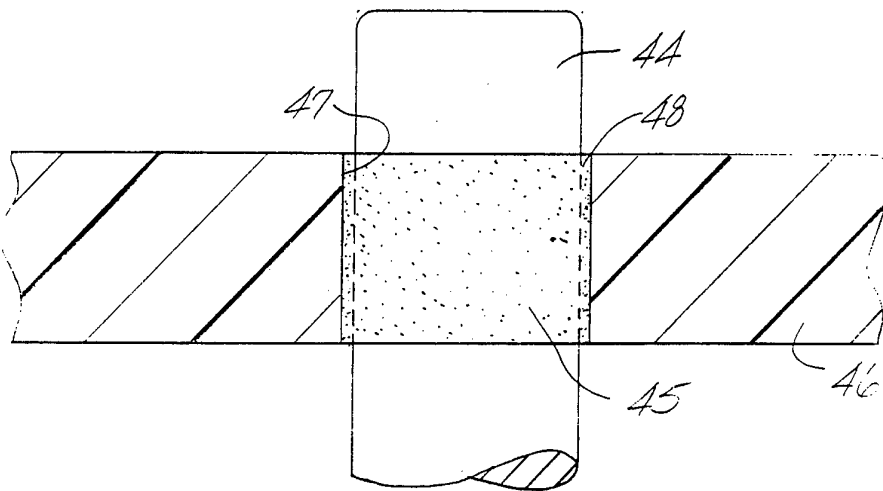

FIG. 9



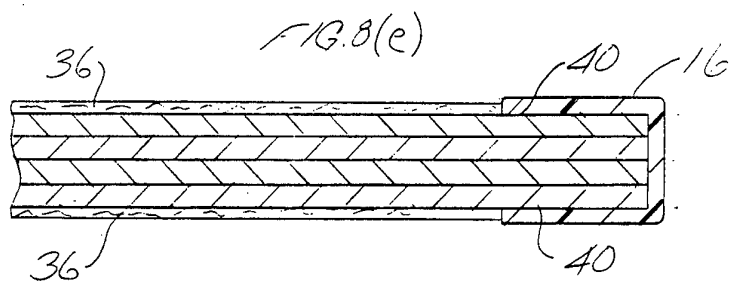
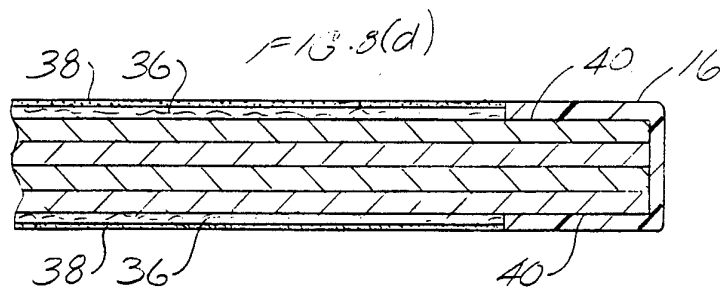
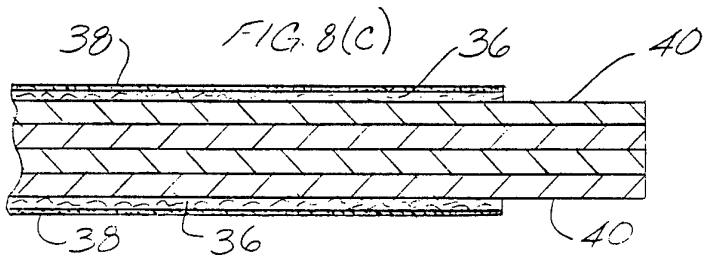
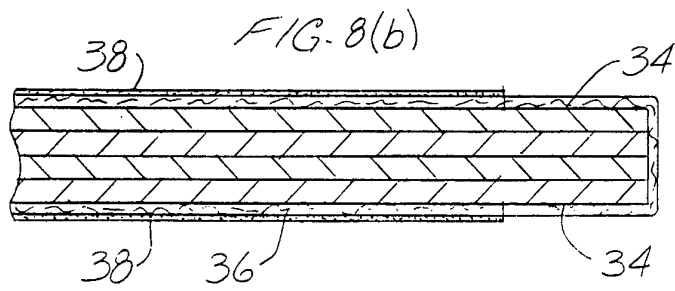
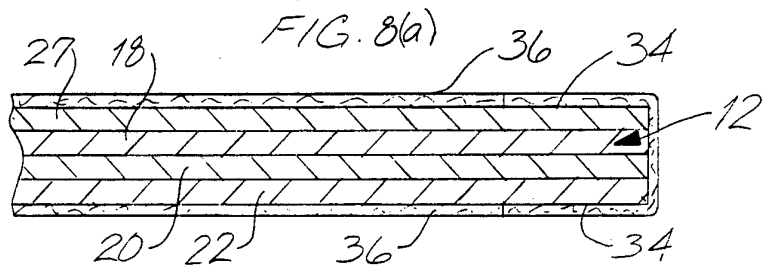
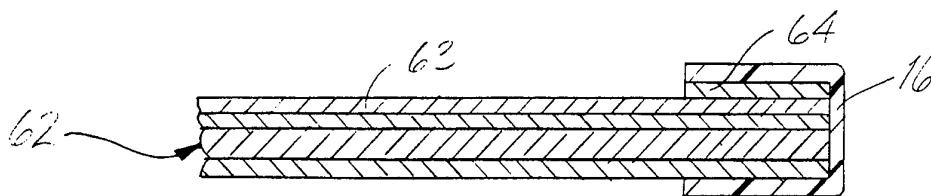

FIG. 10



INTERNATIONAL SEARCH REPORT

International application No.
PCT/US93/01714

A. CLASSIFICATION OF SUBJECT MATTER

IPC(5) :H01M 4/68
US CL :429/234

According to International Patent Classification (IPC) or to both national classification and IPC

B. FIELDS SEARCHED

Minimum documentation searched (classification system followed by classification symbols)

U.S. : 29/2; 429/210,238,245

Documentation searched other than minimum documentation to the extent that such documents are included in the fields searched

Electronic data base consulted during the international search (name of data base and, where practicable, search terms used)

C. DOCUMENTS CONSIDERED TO BE RELEVANT

Category*	Citation of document, with indication, where appropriate, of the relevant passages	Relevant to claim No.
X	US, A, 2,694,099 (ZAHN) 09 November 1954, See figure 5, column 2, lines 23-66 and column 3, lines 3-34.	1,2,6-8, 16,17
Y	US, A, 4,098,967 (BIDDICK ET AL.) 04 July 1978, See the abstract and column 2, lines 8-35.	18-23
A	US, A, 4,761,356 (KOBAYASHI ET AL.) 02 August 1988, See the abstract.	1-17
A	US, A, 4,939,051 (YASUDA ET AL.) 03 July 1990, See the abstract.	1-17

Further documents are listed in the continuation of Box C. See patent family annex.

* Special categories of cited documents:	"I"	later document; published after the international filing date or priority date and not in conflict with the application but cited to understand the principle or theory underlying the invention
"A" document defining the general state of the art which is not considered to be part of particular relevance	"X"	document of particular relevance; the claimed invention cannot be considered novel or cannot be considered to involve an inventive step when the document is taken alone
"E" earlier document published on or after the international filing date	"Y"	document of particular relevance; the claimed invention cannot be considered to involve an inventive step when the document is combined with one or more other such documents, such combinations being obvious to a person skilled in the art
"L" document which may throw doubts on priority claim(s) or which is cited to establish the publication date of another citation or other special reason (as specified)	"Z"	document member of the same patent family
"O" document referring to an oral disclosure, use, exhibition or other means		
"P" document published prior to the international filing date but later than the priority date claimed		

Date of the actual completion of the international search

22 APRIL 1993

Date of mailing of the international search report

07 JUN 1993

Name and mailing address of the ISA/US
Commissioner of Patents and Trademarks
Box PCT
Washington, D.C. 20231

Facsimile No. NOT APPLICABLE

Authorized officer

Nguyen Ngoc Ho
STEPHEN J. KALAFUT NGUYEN NGOC HO
INTERNATIONAL DIVISION

Telephone No. (703) 308-0433

INTERNATIONAL SEARCH REPORT

International application No.
PCT/US93/01714

C (Continuation). DOCUMENTS CONSIDERED TO BE RELEVANT		
Category*	Citation of document, with indication, where appropriate, of the relevant passages	Relevant to claim No.
X	us, a, 5,139,902 (DREWS ET AL.) 18 August 1992, See the abstract and column 3, lines 30-40.	1,2,6-8, 16,17
A	SU, A, 635540 (BARKOWSKIJ ET AL.) 30 November 1978, See the abstract.	1-17