

660034

AUSTRALIA
PATENTS ACT 1990
NOTICE OF ENTITLEMENT

We, Board of Regents, The University of Texas System, the applicant/Nominated Person in respect of Application No. 20268/92 state the following:-

The Nominated Person is entitled to the grant of the patent because the Nominated Person derives title to the invention from the inventors by assignment.

The Nominated Person is entitled to claim priority from the application listed in the declaration under Article 8 of the PCT because the Nominated Person is the assignee of the applicants in respect of the application listed in the declaration under Article 8 of the PCT, and because that application was the first application made in a Convention country in respect of the invention.

DATED this TWENTY THIRD day of NOVEMBER 1993



.....
a member of the firm of
DAVIES COLLISON
CAVE for and on behalf
of the applicant(s)

(DCC ref: 1629188)



(12) PATENT ABRIDGMENT (11) Document No. AU-B-20268/92
(19) AUSTRALIAN PATENT OFFICE (10) Acceptance No. 660034

- (54) Title
METHOD FOR ELASTOGRAPHIC MEASUREMENT AND IMAGING
- International Patent Classification(s)
(51)^s G01N 029/18 G01N 029/10 G01S 015/89
- (21) Application No. : 20268/92 (22) Application Date : 07.05.92
- (87) PCT Publication Number : WO92/21023
- (30) Priority Data
- (31) Number (32) Date (33) Country
699391 10.05.91 US UNITED STATES OF AMERICA
- (43) Publication Date : 30.12.92
- (44) Publication Date of Accepted Application : 08.06.95
- (71) Applicant(s)
BOARD OF REGENTS, THE UNIVERSITY OF TEXAS SYSTEM
- (72) Inventor(s)
JONATHAN OPHIR; IGNACIO CESPEDES; HARI PONNEKANTI
- (74) Attorney or Agent
DAVIES COLLISON CAVE , 1 Little Collins Street, MELBOURNE VIC 3000
- (56) Prior Art Documents
AU 647443 69650/91 G01N 29/00
AU 574430 38805/85 G01N 29/00
AU 566624 25963/84 G01N 29/00
- (57) Claim

1. A method of estimating compressibility of a target body, the method including the steps of:

(a) sonically coupling an ultrasonic source to said target body;

(b) emitting a first pulse of ultrasonic energy from the source along an axis in said target body;

(c) detecting the arrival time of a first echo sequence having at least one echo segment arriving in response to said first pulse of ultrasonic energy;

(d) transaxially moving the ultrasonic source so as to compress said target body;

(e) emitting a second pulse of ultrasonic energy from the source along said axis in the target body following said movement;

(f) detecting the arrival time of a second echo sequence having at least one echo segment, being congruent with at least one said echo segment having arrived in response to said first pulse, arriving in response to said second pulse of ultrasonic energy;

(11) AU-B-20268/92
(10) 660034

-2-

(g) measuring the differential displacement of a plurality of said congruent echo segments;

(h) calculating the strain along said axis following said movement;

(i) measuring the stress imparted along said axis as a result of said movement by:

(1) measuring the shape and area of the ultrasonic source, including any compressor attachments, compressing against the target body;

(2) determining a profile of variations in stress along said axis from the position along said axis and said shape and area of the source; and

(3) calculating a corrected stress along said axis by applying said profile to said measured stress; and

(j) dividing the strain along said axis by the stress along said axis.



INTERNATIONAL APPLICATION PUBLISHED UNDER THE PATENT COOPERATION TREATY (PCT)

<p>(51) International Patent Classification ⁵ : G01N 29/18, G01S 15/89 G01N 29/10</p>	<p>A1</p>	<p>(11) International Publication Number: WO 92/21023 (43) International Publication Date: 26 November 1992 (26.11.92)</p>
<p>(21) International Application Number: PCT/US92/03856 (22) International Filing Date: 7 May 1992 (07.05.92) (30) Priority data: 699,391 10 May 1991 (10.05.91) US (71) Applicant: BOARD OF REGENTS, THE UNIVERSITY OF TEXAS SYSTEM [US/US]; 201 West 7th Street, Austin, TX 78701 (US). (72) Inventors: OPHIR, Jonathan ; 307 Gershwin, Houston, TX 77079 (US). CESPEDES, Ignacio ; 2109 Bancroft, Houston, TX 77027 (US). PONNEKANTI, Hari ; 6601 Dunlap #2022, Houston, TX 77074 (US).</p>		<p>(74) Agent: CAGLE, Stephen, H.; Arnold, White & Durkee, P.O. Box 4433, Houston, TX 77210 (US). (81) Designated States: AT, AT (European patent), AU, BB, BE (European patent), BF (OAPI patent), BG, BJ (OAPI patent), BR, CA, CF (OAPI patent), CG (OAPI patent), CH, CH (European patent), CI (OAPI patent), CM (OAPI patent), CS, DE, DE (European patent), DK, DK (European patent), ES, ES (European patent), FI, FR (European patent), GA (OAPI patent), GB, GB (European patent), GN (OAPI patent), GR (European patent), HU, IT (European patent), JP, KP, KR, LK, LU, LU (European patent), MC (European patent), MG, ML (OAPI patent), MN, MR (OAPI patent), MW, NL, NL (European patent), NO, PL, RO, RU, SD, SE, SE (European patent), SN (OAPI patent), TD (OAPI patent), TG (OAPI patent). Published With international search report. Before the expiration of the time limit for amending the claims and to be republished in the event of the receipt of amendments.</p> <p style="text-align: center; font-size: 2em; font-weight: bold;">6600034</p>

(54) Title: METHOD ~~AND APPARATUS~~ FOR ELASTOGRAPHIC MEASUREMENT AND IMAGING

(57) Abstract

An improved ultrasonic pulse-echo method and apparatus that has particular application in making precision measurements of compressibility in any backscattering material, in particular organic tissue, is disclosed. The method employs a standard transducer or transducer containing device which is translated transaxially, thereby compressing or displacing a proximal region of a target body in small known increments. At each increment, a pulse is emitted and an echo sequence (A-line) is detected from regions within the target along the sonic travel path or beam of the transducer. Resulting time shifts

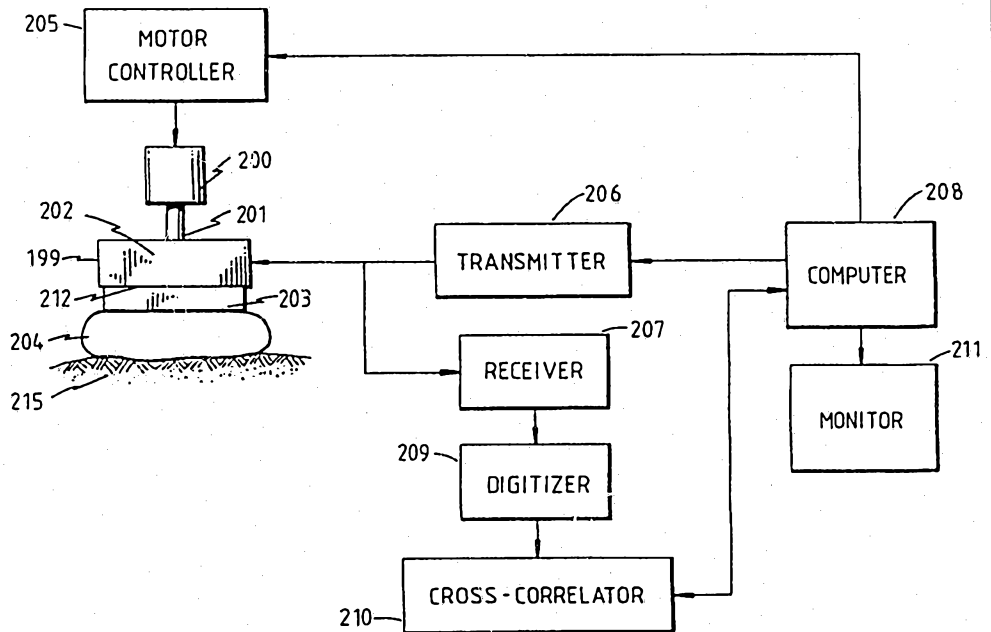

in echo segments corresponding to features in the target, corrected for regions of varying sonic speed along the sonic path, provide relative and quantitative information concerning the strain caused by the compressions. The stress imparted by the transducer and containing device is also determined, corrected for depth along the sonic path. The appropriate values for stress are divided into the respective values for strain along each path to yield an elastogram, or array of compressibility values, of the target.



5

10

15

20

25

**METHOD AND APPARATUS FOR ELASTOGRAPHIC
MEASUREMENT AND IMAGING**

This invention relates generally to a method for performing elastographic diagnosis of a target body. 30 Elastography is a system for measuring and imaging elastic modulus and compressibility distributions in an elastic tissue. It also has application to strain profiling and improved sonographic measurement and imaging. This system is typically based on external compression of a target body, and 35 utilizes one or more transducers, acting as or with a compressor, to generate pre- and post-compression sonic pulses and receive the



5 resulting echo sequences (A-lines) from within the target body. The pre- and post-compression echo sequence pairs may then be cross-correlated or matched to determine the strain along the path of the sonic pulses, and preferably
10 to yield a strain profile of the target body. This strain profile may then be converted into a compressibility profile or elastogram by measuring the stress imposed by the compressing device and calculating the elastic moduli based on the stress and the strain
15 profile.

An elastogram may be considered to be a special form of multi-trace sonogram, wherein each trace is a record or display with depth within a target body of an elastic
20 modulus function of the body. A preferred elastic modulus function for purposes of display is the inverse of the bulk modulus, which provides a measure of compressibility. As explained later in this description, the inverse of the Young's moduli may usually be used
25 instead of the bulk moduli. Less preferred but also helpful are the Young's moduli themselves. Methods for making and using elastograms are described at length in ~~co-pending application no. 7/535,312.~~ U.S. patent no. 5107312.

30 While the methods described ^{in U.S. patent no. 5107312} ~~in application no. 7/535,312~~ produce greatly improved records and understanding of structures of elastic tissues, it has been observed that certain inaccuracies in the resulting elastograms may arise. In particular, inaccuracies have
35 been observed if the transducer and compressor used to compress and insonify a tissue are relatively small in size relative to the depth (or thickness) of the target body, giving rise to decreasing stress in the target body as the distance increases from the compressor. Likewise, inaccuracies have been observed in elastograms and sonograms if the target body is not relatively



homogeneous with respect to sonic speed, giving rise to strata through which sonic pulses travel at differing velocities. The improved methods and apparatus for elastography disclosed herein, while generally enhancing the accuracy of elastograms, have particular application in reducing the effect of such inaccuracies in both elastograms and sonograms.

Traditional ultrasonic diagnosis is achieved by transmitting ultrasonic energy into a target body and generating an image from the resulting echo signals. A transducer is used to both transmit the ultrasonic energy and to receive the echo signals. During transmission, the transducer converts electrical energy into mechanical vibrations. Acquired echo signals produce mechanical oscillations in the transducer which are reconverted into electrical signals for amplification and recognition.

A plot or display (e.g., on an oscilloscope, etc.) of the electrical signal amplitude versus echo arrival time yields an amplitude line (A-line) or echo sequence corresponding to a particular ultrasonic transmission. When the A-line is displayed directly as a modulated sinusoidal pattern at radio frequency ("RF"), it is typically referred to as an RF or "undetected" signal. For imaging, the A-line is often demodulated to a non-RF or "detected" signal.

Ultrasound techniques have been extensively used in the field of diagnostic medicine as a non-invasive means of analyzing the properties of tissue *in vivo* (i.e., living). A human or animal body represents a nonhomogeneous medium for the propagation of ultrasound energy. Acoustic impedance changes at boundaries of regions having varying densities and/or sound speeds within such a target body. At such boundaries, a portion

of the incident ultrasonic beam is reflected. Inhomogeneities within the tissue form lower level scatter sites that result in additional echo signals. Images may be generated from this information by
5 modulating the intensities of pixels on a video display in proportion to the intensity of echo sequence segments from corresponding points within the target body.

Conventional imaging techniques are widely used to
10 evaluate various diseases within organic tissue. Imaging provides information concerning the size, shape, and position of soft tissue structures using the assumption that sound velocity within the target is constant. Qualitative tissue characterization is carried out by
15 interpretation of the grey scale appearance of the sonograms. Qualitative diagnosis largely depends on the skill and experience of the examiner as well as characteristics of the tissue. Images based only on relative tissue reflectivity, however, have limited use
20 for quantitative assessment of disease states.

Techniques for quantitative tissue characterization using ultrasound are needed for more accurate diagnosis of disorders. In recent years many significant
25 developments have been achieved in the field of ultrasonic tissue characterization. Some acoustic parameters, e.g., speed of sound and attenuation, have been successfully used for tissue characterization.

Tissue compressibility is an important parameter
30 which is used to detect the presence of diffuse or localized disease. Measuring changes in compressibility becomes important in the analysis of tissue for pathological conditions. Many tumors are firmer than the
35 surrounding normal tissue, and many diffuse diseases result in firmer or more tender pathology. Examples can

be found in diffuse liver disease, prostate cancer, uterine fibroids, muscle conditioning or disease, breast cancer disease, and many other conditions.

5 Traditionally, physicians routinely palpate various regions of a patient's body to get an impression of tissue firmness or tissue softness. This technique is a form of remotely trying to sense what is going on in terms of tissue compliance. For example, in a liver, if
10 the compliance in an area is sensed to be different from compliance in the surrounding area, the physician concludes from the tactile sensations in his fingers that something is wrong with the patient. The physician's fingers are used to perform a qualitative measurement.

15 In the last several years, a number of articles have appeared in the literature that explore various techniques for measurement and imaging of soft tissue compliance and tissue motion using ultrasound. These
20 techniques rely on one of the following procedures: Doppler ultrasound velocity measurements, cross-correlation techniques to quantify motion in tissues, and visual inspection of M-mode and B-mode images. Additionally a Fourier feature extraction technique has
25 been proposed. Internal mechanical excitation (motion of cardiac structures, arterial pulsation) or external vibration sources of motion produce displacement of the tissues under investigation. The displacements of different tissues are then analyzed by one of these
30 techniques.

 The amplitude and velocity of motion induced by arterial pulsation is generally too low for evaluation with Doppler velocity measurements. However, a number of
35 researchers have used pulsed Doppler and color flow Doppler systems in conjunction with external mechanical

harmonic excitations to determine the elastic properties of tissue. Using a low frequency external excitation source, the velocity of propagation of mechanical waves has been measured and relates to the modulus of

5 elasticity of the tissues. The velocity of vibration of tissues under low frequency vibration excitation has been used to determine their relative compressibility. This technique has been termed "sonoelasticity" and produces

10 B-scans which are "stained" with color coded relative compressibility information. Sophisticated Young's modulus measurements have been applied to determine muscle elasticity as a function of contractility state by measuring Doppler shifts due to very low frequency

15 excitations (10Hz). A similar approach using vibrations in the 100-1000Hz range has been proposed to study dynamic muscle elasticity in vivo.

Cross-correlation techniques allow the use of either internally or externally generated sources of mechanical

20 excitation due to their ability to quantify minute motions of tissue. External harmonic excitation has been used to assess motion of soft tissues with one dimensional and two dimensional correlators. The displacement and/or velocity of internally generated

25 motion also have been measured using one dimensional and two dimensional correlators. Tissue strain caused by arterial pulsation in the liver and by transmitted cardiac motion in fetal lung have been proposed for

30 tissue characterization.

Visual inspection of ultrasound M-mode waveforms has been used to study benign and malignant lesions in liver, pancreas and breast and to observe the elasticity of fetal lung. In magnified B-scans of the fetal thorax

35 paracardiac lung movements have been measured to classify fetal lungs as stiff, intermediate or compliant. The

examination of fetal lung sonograms has been used to evaluate compressibility as an indicator of lung tissue maturity.

5 But, one of the main difficulties in these methods is the lack of definition of the magnitude and direction of the driving force. This difficulty applies to driving forces that are internally generated by the pulsations of the heart and/or the aorta, as well as to those applied
10 externally at low frequency and limited directivity. Further, it is difficult to measure the shape of an internal driving force, limiting the ability to determine how stress resulting from the driving force decreases as a function of distance from the driving force. The
15 inability to define the direction, magnitude and shape of the driving force limits the ability of these methods to provide quantitative information about the elastic properties of the tissue under investigation.

20 In contrast to these methods, elastography is not limited by a lack of definition of the magnitude, direction or shape of a driving force. Elastography preferably uses an external stimulus of known quantity, such as compression of the target body by a known amount
25 or known stress by a compressor, preferably along with cross correlation or least-means-square matching techniques to generate strain profiles of the tissue under investigation. From these strain profiles and the measurement of the stress applied by the compressor, an
30 elastogram (or image of the inverse elastic modulus profile) is determined. The inverse of the elastic modulus profile is typically displayed on the elastogram because strain measurements may be zero, yielding an elastogram with an infinite range of elastic moduli.

35

Thus, elastography provides a pulse-echo system that has particular application in estimating and imaging compressibility in a target body. The target body may be any animal or human tissue, or any organic or inorganic substance that is compressible or compliant. The term "animal tissue" includes "human tissue". An ultrasonic source is used to interrogate the target body. The detection of echo sequences may be at the ultrasonic source. Thus, elastography allows for accurate, localized determination and imaging of an important parameter, compressibility, which has been used qualitatively in medicine for a very long time.

Compressibility of a material is normally defined as the inverse of the bulk modulus of the material. The bulk modulus of a volume may be determined by the following formula:

$$BM = P/(\Delta V/V) \text{ where} \quad \text{Equation 1}$$

20 BM = Bulk modulus
P = the pressure or stress on a tissue segment of interest
 $(\Delta V/V)$ = the volumetric strain of a tissue segment of interest, where
25 ΔV = a change in the volume of the segment, and
V = the original volume of the segment.

In a preferred method of elastography where an external source of compression is applied to stress the target body, it may be generally assumed that the volumetric strain (or differential displacement) along the axis of compression may be determined by the formula:

$$\text{strain} = (\Delta L/L), \text{ where} \quad \text{Equation 2}$$

35 ΔL = a change in the length of the segment along the axis of compression, and
L = the original length of the segment,

Further, it may be generally assumed that the stress on the tissue segment of interest caused by the external source of compression may be determined by the formula:

5 stress = (F/a) , where Equation 3
 F = compressive force applied to the segment, and
 a = area across which the force is applied.

Therefore, applying these assumptions to Equation 1, the
 10 elastic modulus (E) of a tissue segment of interest may
 be estimated by the formula for determination of a
 Young's modulus:

15 E = $(F/a) / (\Delta L/L)$. Equation 4

Further, compressibility (K), the inverse of E, may
 be estimated by the formula:

20 K = $(\Delta L/L) / (F/a)$. Equation 5

Thus, the compressibility of any given segment or layer
 within a material relative to another segment or layer
 may be further estimated from the relationship

25 K_1 = $K_2 (\Delta L_1/L_1) / (\Delta L_2/L_2)$, where Equation 6
 K_1 = compressibility of a first segment or layer;
 ΔL_1 = change in length of the first segment or layer
 along an axis of compression in response to a
 given force;
 30 L_1 = original length of the first segment;
 ΔL_2 = corresponding change in length of a second
 segment or layer;
 L_2 = original length of the second segment or layer;
 and
 35 K_2 = compressibility of the second segment or layer.

In elastography, the velocities of sound in
 different segments or layers may be employed, together
 with time measurements, to calculate distances within the
 40 segments or layers. The ultrasonic signals also provide

may be calculated for all layers based on measurements proximal to the compressor. However, inaccuracies have been observed if the transducer and compressor used to compress and sound a tissue are relatively small in area relative to
5 the depth (or thickness) of the target body, giving rise to decreasing stress in the target body as the distance increases from the compressor. If this decreasing stress is substantial and unaccounted for, levels of decreasing compressibility may appear on the elastograms as a function
10 of increasing distance from the compressor.

According to the present invention there is provided a method of estimating compressibility of a target body, the method including the steps of:

15 (a) sonically coupling an ultrasonic source to said target body;

(b) emitting a first pulse of ultrasonic energy from the source along an axis in said target body;

(c) detecting the arrival time of a first echo sequence
20 having at least one echo segment arriving in response to said first pulse of ultrasonic energy;

(d) transaxially moving the ultrasonic source so as to compress said target body;

(e) emitting a second pulse of ultrasonic energy from
25 the source along said axis in the target body following said movement;

(f) detecting the arrival time of a second echo sequence having at least one echo segment, being congruent with at least one said echo segment having arrived in
30 response to said first pulse, arriving in response to said second pulse of ultrasonic energy;

(g) measuring the differential displacement of a plurality of said congruent echo segments;

(h) calculating the strain along said axis following
35 said movement;

(i) measuring the stress imparted along said axis as a result of said movement by:



(1) measuring the shape and area of the ultrasonic source, including any compressor attachments, compressing against the target body;

5

(2) determining a profile of variations in stress along said axis from the position along said axis and said shape and area of the source; and

10

(3) calculating a corrected stress along said axis by applying said profile to said measured stress; and

15

(j) dividing the strain along said axis by the stress along said axis.

The ability of embodiments of the invention to quantitatively measure the compressibility or compliance of tissue in localised regions provides help with (1) objective quantification of commonly used clinical signs, (2) localising these measures, (3) making the measurements deep in tissue with simple equipment, (4) observing new tissue properties, which may be related to pathology, not seen by other known means; and (5) constructing images of a compressibility or compliance parameter *in vivo*, which may be used alone or in conjunction with ordinary sonograms. Diseased tissue, such as tumors, may be harder or softer than normal tissue, and thus have a

25
30



different amount of compressibility. In this regard, elastography gives promise of a distinct advantage over prior art methods in the accurate detection of diseases such as breast cancer and prostate cancer and
5 localization of tumors at an early stage. Another advantage of elastography is that its sensitivity may be greater than sonography, because of its measurement and imaging of compressibility and not just echo amplitudes, allowing for better visualization of target bodies.
10 Still another advantage of elastography is the accurate imaging of sub-surface tissue while avoiding the use of ionizing radiation from x-rays.

It will be noted at this point that elastography is
15 contemplated to have significant applications other than in medicine. One such application, for example, is in the quality grading of beef. Elastography may be used to quantitate both the tenderness of beef and the fat content (marbeling) before and after slaughter. This
20 ability is economically important in determining when to slaughter cattle. Other applications may include, for example, interrogation of materials and products such as cheese or crude oil that are physically displaceable by the movement of a transducer. Other objects and
25 advantages of elastography will become readily apparent from the ensuing description.

embodiments of

In a broad sense, the present invention comprise an ultrasonic system for producing improved elastograms and
30 sonograms of elastic target bodies, and notably animal and human tissue. In one broad aspect, elastography comprises sonically coupling a sonic device to a target body to determine its compressibility. The sonic device is used to emit an ultrasonic signal and receive
35 returning echo sequences from along a sonic path in the target body. The sonic device is then moved a known



amount along the axis of the sonic path, and the target body is interrogated again along the sonic path. Congruent segments in echo sequences from the different sonic signals are then preferably cross correlated or
5 matched, and the temporal displacements are used to calculate the strain along the sonic path. This procedure is repeated for a plurality of sonic paths, either sequentially or by means of a sonic array, to produce strain profiles for the target body.

10

To obtain a compressibility profile, a second body having a known, preferably uniform, elastic modulus may be first sonically joined to and between the target body and the sonic device. The strain profiles of both bodies
15 may then be determined using the steps described above. The stress caused by the movement of the sonic device may then be determined from the strain profiles and elastic modulus of the second body. Compressibility profiles for the target body may be obtained by dividing the values
20 for the strain profiles in the target body by the stress. The resulting compressibilities may be further arranged as an elastogram, a positional multi-dimensional plot or picture of the relative magnitudes of compressibility of a tissue or other target body.

25

In another ^{embodiment} aspect, the invention resides in using the above method of elastography ^{is used,} but further ^{steps are taken} ~~correcting~~ ^{to correct} for variations in stress along the sonic path. These variations may occur in instances where a sonic device,
30 which is employed to stress and compress the target body, has a small cross-sectional area relative to the depth or thickness of the target body. These variations in stress may be determined by first measuring the dimensions of the surface of the sonic device (which may include a transducer in combination with a compressor) which
35 contacts the second body. These measured dimensions may



then be applied to analytically derive the variations in stress within the target body as a function of position relative to the sonic device. The result is, in effect, a stress profile. Once derived, these variations in stress may
5 be applied to correct the values for the stress profiles, as well as the resulting compressibility profiles and elastograms for the target body, previously determined by use of the above-described preceding embodiment.

10 In another embodiment, the above variations in stress may be experimentally derived. Thus, a body of known elasticity may be compressed by the sonic device and the resulting strains along varying sonic paths inside the body may be measured. The variations in stress may then be
15 calculated as a function of position relative to the sonic device. From these known variations the corrected values for the stress and compressibility profiles and elastograms may then be determined.

20 In yet another embodiment of the invention, appropriate time delays, necessary to correct for variations in echo sequence travel time through regions of the target body having different speeds of sound, may be determined and applied to each echo sequence. The resulting time shifts in
25 echo sequences correct for distortions that might otherwise occur when there are different regions within a target body, e.g., fat and muscle tissue, that have differing sonic velocities.

30 Embodiments of the invention will now be described by way of example with reference to the accompanying drawings in which:



Fig. 1a shows an embodiment of an elastographic apparatus where a transducer and compressor are sonically coupled to a target body to interrogate a distal tissue region within the target body.

5

Fig. 1b shows a plot of an RF echo signal originating from the distal tissue region interrogated in Fig. 1a.

10

Fig. 2a shows the transducer and compressor of Fig. 1a imparting a small compression to a proximal region of the target body.

15

Fig. 2b shows a plot of a typical pre- and post-compression RF echo signal pair originating from the distal tissue region as interrogated in Fig. 2a.

20

Fig. 2c shows a plot of a cross correlation of the echo signal pair shown in Fig. 2b.

Fig. 3a shows the axial strain in foam as a function of depth using a 127mm circular compressor.

25

Fig. 3b shows the normalized stress in foam as a function of depth using various sizes of circular compressors.

30

Fig. 3c shows the normalized stress in dB as a function of z/a , the depth divided by the area of a circular compressor.

Fig. 4a shows a cross sectional view of an apparatus for determining stress distribution under a given compressor.

35

Fig. 4b shows a cross sectional view of a stress distribution under a compressor as a function of position relative to the compressor.

5 Fig. 5a shows a photograph of a phantom consisting of two triangular foam pieces joined along a diagonal seam.

10 Fig. 5b shows a B-scan of the phantom pictured in Fig. 5a.

Fig. 5c shows the elastogram corresponding to the B-scan shown in Fig. 5b.

15 Fig. 5d shows the depth-corrected elastogram corresponding to the B-scan shown in Fig. 5b.

20 Fig. 6 shows an embodiment of an apparatus in which a compressor is coupled to a target body for purposes of experimentally determining the variations of stress with depth in the target body.

Figure 1a shows the transducer 10 and compressor 10a sonically coupled to a target body 15. An ultrasonic pulse 18 is shown propagating within sonic beam 20 toward an echo source 25 on beam axis 12. As the pulse 18 propagates through the target 15, corresponding echoes are generated and arrival times noted at the transducer aperture 11. The combination of all echoes generated from reflections within the beam 20 is the echo sequence or A-line corresponding to pulse 18.

25
30

A radio frequency ("RF") signal plot of the A-line acquired from pulse 18 is shown in Fig. 1b. The amplitude of the signal in volts is plotted against echo arrival times in microseconds (μ s). Later arrival times

35

correspond to progressively deeper regions within the target body 15. An echo segment or echo wavelet 30, within a chosen arrival time window, is selected as a reference. The time window may be selected based on
5 anatomical data from ultrasound imaging, or may be arbitrary, e.g., every x micro seconds. The echo segment or wavelet 30 originates from the echo source 25.

Figure 2a shows the transducer 10 and compressor 10a
10 being translated along axis 12 to impart a small compression (Δy_1) to the tissue. After the transducer 10 and compressor 10a compress the target body 15, a second pulse 22 is emitted and the corresponding A-line segment is acquired from a desired depth within the tissue.

15

Fig. 2b shows an RF plot pairing a typical pre-compression A-line, corresponding to pulse 18, and a post-compression A-line, corresponding to pulse 22. The echo segment or wavelet 32 associated with a given echo
20 source and pulse 22 is time shifted with respect to the same segment of wavelet 30 associated with the same echo source and pre-compression pulse 18. The time shifted wavelet 32 may be tracked within the selected time window using standard pattern matching techniques. The window
25 selected must be such that the wavelet of interest will not be shifted out of the window. This selection may involve the size of the window or the positioning of the window. The window selected should reveal both wavelets or echo segments. The arrival time of echo segment or
30 wavelet 32 is prior to that of echo segment or wavelet 30 above, since the distance between aperture 11 and feature 25 was shortened by the compression Δy_1 .

Fig. 2c shows the cross-correlation function between
35 the pre- and post-compression A-lines shown in Fig. 2b.

In a preferred method of elastography, a transducer and compressor are positioned on or otherwise coupled to a target tissue and advanced axially toward the target to compress the target. Alternatively, elastography may be practiced by retracting a transducer and compressor from a previously compressed position. Further, in both methods the transducer may alone serve as the compressor. Since the relatively large size of the compressor precludes penetration of the tissue, small tissue displacements occur instead. A pulse is emitted from the transducer prior to the displacement, and a first echo sequence received in response to the pulse is recorded. Following displacement, a second pulse is emitted and a second echo sequence is recorded in response to transmission. Next, a comparison of the waveforms is made to reveal a decreasing displacement of the tissue structure with depth. The decrease will generally be asymptotic in character.

In the foregoing method, a single compression of a homogenous target body has been described. It will be apparent, however, that other conditions may be employed. Thus, multiple compressions, repetitive or real time compressions, varying waveforms and other signal sources, such as array transducers, may be used. These signal sources, for example may be non-repetitive and may generate spike-like signals.

Further, an internal source of compression, alone or in conjunction with an external compressor, may be used. In the case of an internal source of compression, such as the heart or arteries, the tissue of interest should preferably be located sufficiently distant from the internal source of compression such that stress caused by the internal source of compression, even while changing as a function of time, remains substantially uniform

throughout the tissue of interest. A transducer may then be sonically coupled to the target body, preferably with a compliant body of known uniform elasticity sonically coupled between the transducer and the target body, such
5 that the tissue adjacent to the transducer compresses against the compliant body and transducer as the tissue is compressed by the internal source of compression, and decreases in stress against the transducer and compliant body as the stress caused by internal source of
10 compression decreases in the tissue of interest. The strain in the compliant body and tissue of interest may then be sonically measured using the method described herein, and the stress against the compliant body determined from elasticity and strain measurements for
15 the compliant body. Finally, this stress may be assumed to be the level of stress throughout the tissue of interest, and used with the measured strains to determine the compressibility profile in the tissue of interest.

20 In tissue that is not homogeneous, the shifting of tissue in various segments will differ. For example, if a segment of tissue is less compressible than the overall tissue containing the segment, the tissue in the segment will compress or strain less than if the segment of
25 tissue were of the same compressibility as the tissue as a whole. Alternatively, when a segment is more compressible than the tissue as a whole, the segment will compress or strain more than if the segment were of the same compressibility as other segments. The presence of
30 a strain "defect," or segment of different compressibility, along the compression axis in a target body influences all other strains along that axis, increasing or decreasing the otherwise proportional change in strain with depth along the axis. In this way
35 a strain "defect" is said to be "smeared" along the axis. For this reason, it may be preferable to convert the

strain profiles into elastic modulus profiles. Since the elastic modulus is a basic tissue property, it may be ultimately a more reliable parameter. In any event, it is possible to obtain useful images from strain or
5 elastic modulus data.

In order to illustrate these principles, it is convenient to consider a simple one-dimensional cascaded spring system, where the spring constants represent the
10 elastic moduli of tissue regions. We assume that all three springs are equal and are of length ℓ , and that each spring represents the behavior of a cylindrical tissue element with unit cross section. If the top of the first tissue element is compressed by an axial
15 downward force such that the overall length of the system is reduced by $(2\Delta y)$, then a simple statics calculation shows that each and every spring will shrink by $\Delta \ell = 2\Delta y/3$. If we define the strain of each spring = $\Delta \ell/\ell$, it is clear then that the strain is constant for all
20 springs, and is equal to $2\Delta y/3\ell$.

Where the center spring has been replaced by an infinitely stiff spring, i.e. $E = \infty$, the total displacement is taken up by two outer springs only.
25 Thus, the strain in the two outer springs will increase to $\Delta y/\ell$.

It is evident from this example that a strain profile is dependent on the initial compression and on
30 the number and stiffness of all springs. A given local measured value of the strain is influenced by the elastic properties of elements located elsewhere along the axis of compression. For these reasons, it appears that while strain profiling may be useful for imaging, it may be of
35 limited use for quantitative estimation of local tissue elasticity.

If instead of imparting a known displacement a known stress is applied, it becomes possible to estimate the elastic modulus of each component in this system of springs, since the stress remains constant with depth in this one dimensional system. In this case, the measurable strain in each spring and the known stress on each spring may be used to construct an elastic modulus profile along the compression axis. Such a profile would be independent of the initial compression, and the interdependence among the component springs would disappear.

Further, the stress applied to the target body may be measured ultrasonically by interposing an anterior compliant standoff layer which has a known value of E , and which allows the free passage of ultrasonic waves. The simultaneous measurement of the strain in this layer allows the computation of the stress acting on the target. This layer may consist of compressible or compliant material such as rubber, sponge, gels, etc. The material should be compressible and provide for an ultrasonic transmission path to the tissue. The material may be echogenic, but it is not necessary.

In the more realistic three-dimensional case, one would expect that the applied stress would not be constant along the axis of compression. The reason for this lies in the fact that stresses along transverse springs become important, and since their vertical force components are a function of the displacement which in turn is a function of depth, the resultant forces along the compression axis vary with depth. On the other hand, enlarging the area of the compressor, the transverse springs that are actually stretched, and hence contribute to the depth dependent stress field, become less important and the applied stress field becomes more

uniform. Experiments have confirmed that larger compressors cause more uniform axial stress fields.

5 In elastography, however, the velocities of sound in different segments or layers are used, together with time measurements, to calculate distances within the target body. More specifically, elastograms are based on time shift differences among segments of ultrasound A-lines and preferably, when based on more than about 64 data
10 points, rely heavily on cross-correlation computations. The use of cross-correlation analysis for time shift estimation derives from Fourier theory, and is well known in the art. In recent years a number of industrial and medical applications have utilized cross-correlation
15 analysis for time shift measurements. The application of ultrasonic correlation techniques to the measurement of flow velocity of coal slurries has been described. Similarly, an ultrasonic correlation flowmeter for pulp suspension has been proposed. In the medical field, a
20 number of publications describe the measurement of blood velocity profiles using one-dimensional and two-dimensional correlators, as well as applications of cross-correlation measurements for tissue motion evaluations, described above.

25

The generation of an elastogram involves a pairwise evaluation of the time shift between congruent segments in an A-line pair, preferably by means of cross-correlation techniques. The linear cross-correlation of
30 segment pairs may be computed using FFTs (fast Fourier transforms). The temporal location of the maximum peak of the cross-correlation function may be used to estimate the time shift between the data in the two segments.

35

However, the time shift differences among segments of an ultrasound A-line may also be evaluated by using a

least-means-square match analysis, which is also well known in the art, or by manually measuring the differences between A-lines on a display or picture, instead of by cross-correlation. When there are less than about 64 data points being analyzed, a time domain computation, such as a least-means-square match, may often take less time than a fourier domain cross-correlation computation will take to determine the time shifts. Further, a least-means-square match analysis may be computed for a limited number of time-lags, where the approximate time shift is known, while cross-correlation using an FFT computation must analyze the entire data sequence. Thus, a least-means-square match may be faster than cross-correlation where the approximate time-shift is known, allowing a time-shift determination to be made by matching only a portion of the echo sequences.

By way of illustration only, one approach to elastography could involve the derivation of an elastogram from a strain image created from 40-60 A-line pairs obtained with a 1-2 mm lateral translation of the transducer between pairs. An A-line pair consists of the original A-line which is obtained with the transducer slightly pre-compressing the target in order to assure good contact, and a compressed A-line which is obtained after axially compressing the target an additional Δz . The compressed A-line would be shorter than the original A-line by $2\Delta z/c$, where c is the speed of sound in the target. The length of the A-line pair is taken to be that of the original A-line; zeros are appended to the compressed A-line. These A-lines would be obtained from a 12 cm total depth in the target, and divided into 40-60 overlapping 4 mm segments obtained every one or two mm.

The data acquisition, and therefore the time scale, is relative to the face of the transducer. Thus one can

observe that the relative shift of the signal at the beginning of an A-line pair is very small, whereas towards the end it is significant. In general, the time shift of the compressed A-line relative to the uncompressed A-line would increase from 0 to a maximum of $2\Delta z/C$.

In general, the precision of the time shift estimate improves with increasing segment size. However, it is typically better to keep the segment size small to improve the axial resolution of the estimate. Additionally, because of the relative compression and the resultant progressive distortion of the data within a segment pair, the cross-correlation estimate may deteriorate with increasing segment size. This, in turn may degrade the precision of the estimate. Thus, there are two competing mechanisms that affect the precision of a time shift estimate as a function of the segment size. Although this trade-off has not been studied in depth, it has been observed that a segment size of about 4 mm with about 3 mm overlap between segments leads to strain data which may result in reasonable images with about 1 mm axial resolution.

The resolution of a measured time shift may be bounded by the sampling period at which the data is digitized. To improve the resolution, some interpolation algorithms have been proposed. For example, a quadratic interpolation algorithm has been shown to be effective and it is simple to implement. See, Foster et al., "Flow Velocity Profile Via Time-Domain Correlation," IEEE Trans. Ultrason. Ferroel. Freq. Control, Vol. 37, No. 2, 164-174 (1990); See also, Boucher et al., "A Method of Discrete Implementation of Generalized Cross-Correlator," IEEE Transactions: Acoustics, Speech and Signal Processing, Vol. ASSP-29, No. 3 (June 1981). This

algorithm first fits a second-order polynomial which passes through the peak sample value of the cross correlation and its two neighbors using the Lagrange polynomial interpolation. Then it analytically locates the peak of the fitted polynomial, assigning that temporal value to the improved time shift estimate.

Returning to the illustration, after processing one A-line pair a set of time shifts, t_1 through t_{60} , may be obtained. The corresponding strain profile may then be defined by the relationship

$$S_i = \frac{t_{i+1} - t_i}{2\Delta x/c}; \quad i = 1 \text{ to } 59 \quad \text{Equation 7}$$

where s_i is the strain estimate for segment pair i , and where Δx is an axial increment.

The process may then be repeated for all A-line pairs, resulting in an array of strain data. These values may then be scaled and assigned to an intensity for display, e.g., an intensity varying within 256 grey scale levels. Due to the large dynamic range of some strain data, contrast stretching may be applied in order to vary the variation in particular strain ranges. For example, 256 grey scale levels may be assigned to a user specified strain range, thus stretching the contrast in that region.

In general, elastography contemplates sonically coupling an ultrasonic source to a target body; energizing the ultrasonic source to emit a first ultrasonic signal or pulse of ultrasonic energy from the source along an axis into the target body; detecting from

a region within the target body a first echo sequence including a plurality of echo segments resulting from the first transmitted signal; displacing the target body along the axis while maintaining coupling between the ultrasonic source and the target body; energizing the ultrasonic source to emit a second ultrasonic signal along the axis into the target body; and detecting from the region within the target body a second echo sequence including a plurality of echo segments resulting from the second transmitted signal; and measuring the differential displacement of the echo segments. A plurality of first ultrasonic signals or pulses of ultrasonic energy may be emitted and a plurality of first echo sequences detected before compressing the target body. Then a plurality of second signals and pulses are emitted along a plurality of parallel paths and a plurality of second echo sequences are detected.

In one embodiment of elastography, a transducer is the ultrasonic source and is sonically coupled to direct an ultrasonic signal or pulse of ultrasonic energy into the tissue along a radiation axis such that movement of the transducer along the axis effects a change in compression of the tissue.

In a preferred embodiment of elastography, the ultrasonic source is a transducer sonically coupled to a tissue of interest. A first pulse of ultrasonic energy is emitted along a path into the target body and the arrival of a first echo sequence (A-line) including one or more echo segments is detected from regions within the tissue along the path resulting from the first pulse of ultrasonic energy. Thereafter, compression is changed within the tissue along the path. The compression change may be accomplished by transaxially moving the transducer along the path to compress or displace a proximal region

of the tissue. A second pulse is emitted, and the arrival of a second echo sequence including one or more echo segments common to the first echo sequence is detected in response to the second pulse. The differential displacements of at least one echo segment are measured. The echo sequences detected are from common regions within the tissue.

A comparison of the first and second echo sequences or waveforms with intervening compression reveals a generally decreasing displacement of tissue structures with depth. In a homogeneous medium, the rate of decrease will tend to be asymptotic. Of particular interest is the differential displacement per unit length - i.e., strain. In a homogeneous compressible medium, the strain will tend to be constant along the axis of compression. In a non-homogeneous medium, the strain varies along the axis of compression.

The strain of a tissue may be calculated using the arrival times of first and second echo sequences from proximal and distal features in a target body -- i.e., tissue -- using the following equation:

$$\frac{(t_{1B} - t_{1A}) - (t_{2B} - t_{2A})}{(t_{1B} - t_{1A})} \quad \text{Equation 8}$$

t_{1A} = arrival time of a first echo sequence from a proximal feature;
 t_{1B} = arrival time of a first echo sequence from a distal feature;
 t_{2A} = arrival time of a second echo sequence from a proximal feature; and
 t_{2B} = arrival time of a second echo sequence from a distal feature.

The arrival times of the echo segments from a common point detected in response to a first and second pulse of ultrasonic energy are compared. The common points may be

found in features occurring within the echo signal. The time shifting of the two echo segments is used to determine compressibility.

5 Thus, if no change in arrival time has occurred with
an intervening compressive force, it follows that a
target body has not been compressed along the travel path
leading to the source of the echo segments. On the other
hand, if the arrival time of the second echo segment is
10 smaller than the arrival time of the first echo segment,
it is clear that compression has occurred and that the
target body is compressible. Moreover, the difference in
arrival times, taken together with other available data,
makes it possible to quantify the compressibility of the
15 target body.

In another embodiment of elastography, body segments
which extend along the transmission path of the
ultrasonic pulses are selected within a target body and
20 separate first and second echo segments detected from
within each body segment. Thus, a series of first and
second echo segments is detected for the body segments
selected for interrogation. Preferably, the echo
segments are detected from the proximal and distal ends
25 of body segments relative to the ultrasonic source.
Measurement of the time shifts of echo segments in the
first and second echo sequences which correspond to the
proximal and distal ends of each body segment are then
made. By studying the time shifts, it becomes possible
30 to determine whether changes in compressibility occur
along the ultrasonic beam within the target body.

A preferred embodiment of elastography involves (1)
sonically coupling a material with a known Elastic
35 Modulus and speed of sound to the surface of the target
body; (2) emitting a first pulse of ultrasonic energy

along a path through the material into the target body;
(3) detecting a first echo sequence including a plurality
of echo segments, from within the target body resulting
from the first pulse; (4) forcing the material against
5 the target body sufficiently to displace the target body
while maintaining acoustic coupling between the material
and the target body; (5) emitting a second pulse of
ultrasonic energy along the path through the material
into the target body; and (6) detecting a second echo
10 sequence including a plurality of echo segments common to
the first echo sequence, resulting from the second pulse.
The presence of the material with a known Young's modulus
and speed of sound makes it possible to determine the
Young's modulus of the target body. If the target body,
15 itself, has multiple layers, it also becomes possible to
determine the Young's moduli of the individual layers.
The application of Young's modulus to these matters is
explained later in this description.

20 At this point it is worth noting that elastography
takes advantage of the acoustical properties of
physically compressible or displaceable materials. These
materials -- for example, animal or human tissues --
often contain a large number of acoustic "scatterers".
25 The scatterers, being small compared to the wavelength of
the sound frequencies involved, tend to reflect incident
sound energy in all directions. For example, in
homogeneous tissue regions, scatterers may comprise a
collection of nearly identical reticulated cells. A
30 particular arrangement of scatterers will shift in
response to axial forces from the transducer, changing
the time an echo is received from the arrangement. The
echoes received from the various arrangements of
scatterers form an echo sequence. A selected echo
35 segment or wavelet of the reflected RF signal corresponds
to a particular echo source within the tissue along the

beam axis of the transducer. Time shifts in the echo segment or wavelet are examined to measure compressibilities of tissue regions. It is important that the shape of the echo segment or wavelet not change significantly, due to compression, such that
5 identification of the wavelet is not possible, and that the signals not be decorrelated beyond an acceptable range. The time shift can be determined by analyzing the data in a computer or by a visual examination, but the
10 analysis will generally be easier with a computer.

Studying an internal region of the human body is accomplished by sonically coupling an ultrasonic transducer to the body so as to emit an ultrasonic signal
15 along an axis into the region, and such that movement of the transducer along the axis relative to the region will change the compression of the body between the transducer and the region; energizing the transducer to emit a first signal along the axis into the body and the region;
20 detecting the arrival at the transducer of a plurality of spaced echo segments resulting from the first signal and coming from the region; moving the transducer along the axis relative to the region sufficient to change the compression of the body between the transducer and the
25 region while maintaining said sonic coupling; energizing the transducer to emit a second signal along the axis into the body and said region; detecting the arrival at the transducer of each echo segment resulting from the second signal; and determining the strains produced in
30 segments of the region between the pairs of echo segments.

Elastography is of particular interest in interrogating organic tissue, especially human and other
35 animal tissue. Thus, as a transducer is pressed against such a material, scatterers in a region within the

material are displaced from one position to another. For elastic materials, release of the pressure enables the scatterers to return to their original position. A principal object of such interrogation is to use echo
5 signals from the tissue in strain studies which may reveal the presence of abnormalities. In general, when employing a transducer to transmit signals into a living body, care should be taken to coordinate the transducer sound signals with naturally occurring movements. Thus,
10 in the human body, the transducer should normally be activated at times which will minimize interference by movements of structures such as the pumping of the heart or pulsation of an artery. It should be noted, however, that it may be possible to use such movements, where the
15 stress and strain resulting from such movements may be determined, either in place of or in conjunction with an external source of compression, in the practice of elastography and of the invention.

20 It will be noted that the transducers employed in elastography need not be in direct contact with the materials to which they are applied. It is necessary, however, that transducers be sonically coupled to the materials in a manner such that movement of the
25 transducers will result in displacement of the materials. Sonic coupling methods and agents are well known in the art.

It will be also noted that a material may be
30 displaced according to elastography either (a) by advancing a transducer against a compressible elastic material to increase compression, or (b) by retracting a transducer from a compressed position within the material. Changing compression means compressing or
35 decompressing the target body.

As noted above, it is not necessary that an echo from a discrete feature in a tissue or other compressible material be employed. It is sufficient that an identifiable echo segment be present in the echo signal resulting from a transmittal signal. Even though the physical features within a material responsible for a selected echo segment may not be clearly known, the selected echo segment is an adequate reference for the purposes of elastography. Thus, the compression of a material and signal travel times determined before and after such compression may be based upon comparison of time shifts in the echo segments. Similarly, the recovery of an elastic material from an initially compressed condition and the signal travel times before and after such recovery or decompression may be based upon comparisons of time shifts in the echo segment.

Elastography may also be employed for estimating compressibility or compliance in targets having multiple layers. It will be noted that the terms "compressibility" and "compliance" in the present context have generally similar connotations. In any event, the compressibility in each of the progressively deeper layers is estimated by employing the same techniques discussed above. For example, the compressibility may be estimated in each layer from only two echo sequences along the axis of radiation. The echo sequence may be divided into echo segments corresponding to the layers. Thus, imaging of the compressibility parameter in a plane or volume of a target body may also be accomplished by appropriate lateral translation of the transducers.

Referring now to Figs. 3a and 3b, another preferred embodiment of elastography can be illustrated. In this embodiment, the variation in stress based on depth is determined by application of an appropriate formula

describing stress as a function of other known quantities, such as depth and the radius of the compressor.

5 It is known that the behavior of axial stress under some compressors may be analytically estimated. A solution for the axial stress under a circular compressor has been analytically derived, by extension of a solution to the Boussinesq problem, in Saada, Elasticity, Theory
10 and Applications, Ch. 14 (Pergamon Press, NY, 1974), viz.,

$$\sigma(z) = \sigma(0) \left[\frac{z^3}{(a^2 + z^2)^{3/2}} - 1 \right], \quad \text{Equation 9}$$

15 where $\sigma(z)$ is the stress in the axial direction (where a negative value indicates an upward stress), $\sigma(0)$ is the uniformly distributed applied stress (where the total load is $\pi a^2 \sigma(0)$), a is the radius of the circular compressor, and z is the axial distance). Equation 9 may
20 be rewritten as

$$\sigma(z) = \sigma(0) \left[\frac{1}{\left[1 + \left[\frac{a}{z} \right]^2 \right]^{3/2}} - 1 \right], \quad \text{Equation 10}$$

25 which emphasizes the fact that the stress profile is dependent only on the dimensionless ratio (z/a) .

Fig. 3a illustrates a varying decrease in axial stress. The strain observed (line 1) in a foam phantom

exhibits a varying decrease as a function of depth when a 127mm circular compressor has been utilized. This observed strain corresponded well with the analytically estimated strain (line 2), derived by dividing the elastic modulus into the analytically determined variation in stress. Because the elastic modulus was approximately the same throughout the foam phantom, the values along lines 1 and 2 are in approximately direct proportion to the corresponding values for stress as a function of distance.

Fig. 3b illustrates a plot of analytically derived stress profiles for circular compressors of varying size. The normalized stress ($|\sigma(z)/\sigma(0)|$) decreases rapidly for small compressors, attaining a relatively constant yet small value at a shallow depth. On the other hand, the stress profiles of larger compressors tend to drop progressively much more slowly. Fig. 3c further illustrates the normalized stress in dB as a function of the quantity (z/a) , the ratio of the axial distance from the compressor and the radius of the circular compressor. It may be observed that only modest reductions in stress are encountered for values of (z/a) that are smaller than or equal to 1.

Formulas such as those derived by Saada for circular compressors may be derived for more complicated shapes (some of which have been derived in Saada, *supra*, Ch. 14). On and off axis, the stress distribution for a given compressor may also be experimentally derived. A preferred experimental method for deriving this stress distribution is illustrated in Fig. 4a. A transducer 301 with aperture 303 is sonically coupled to a target body 300 of known elasticity, preferably with an elasticity similar to that of the types of tissue that the compressor will be used with, opposite the compressor

305. An A-scan is then taken of the target body along sonic path 307. The compressor 305 is then compressed a known distance Δy , a second A-scan taken, and the stress profile determined from the elasticity and measured strain along the A-scan. After the stress distribution is determined along one A-scan, the compressor 305 is lifted from target body 300, moved laterally a known distance, and placed in contact with the target body 300 again. The stress distribution is then determined along the new (relative to the compressor) sonic path according to the same method as for the first sonic path. This process is repeated until a desired number of stress distributions have been obtained. Finally, a three-dimensional stress distribution for the compressor 305 is estimated based on the measured stress distributions. Fig. 4b illustrates what a cross-sectional plot of such an estimated stress distribution might look like in a target body. The curves represent stress distribution isobars, with the value of the isobars being relative to the stress $\sigma(0)$ of the region in the target body immediately adjacent to the compressor 305.

In another embodiment, the target body 300 may also be moved, by known amounts, relative to transducer 301 and compressor 305. By moving the target body 300 certain distortions may be minimized, such as distortions that might result from repetitively measuring strain along a sonic path where fixed scatterers exist along that sonic path. In yet another embodiment, an array of transducers is used as both the compressor and transducer to interrogate itself, the array being fired both before and after compression, yielding measurements of the strain (and thus stress) distributions along the different sonic paths.

According to a presently preferred embodiment of elastography, after the stress distribution has been determined by one of the methods described above it is stored, such as by any conventional means like electronic or magnetic media or computer memory, for later recall. The stress distribution is subsequently recalled, following an elastographic measurement of a desired target body using the compressor 305. The appropriate amount of stress for each echo sequence segment of interest is then determined, by matching an echo sequence segment's known position relative to the compressor with the value for stress at the same relative position for the stress distribution. The compressibility of each segment may then be determined by applying the appropriate value of stress to the strain of the segment, where the strain may be determined from the measured time shifts in the echo sequences according to the elastographic method described above and the applied stress may be measured from a compliant layer in front of the transducer 301.

To further explain this preferred embodiment, reference is made to Fig. 5a, showing a phantom consisting of two triangular foam pieces joined along a diagonal seam. This phantom was obtained by diagonally cutting a square foam block with a porosity of ~ 20 ppi, and then tightly joining the cut pieces. However, as seen in Fig. 5a, the diagonal seam is not visible when a B-scan was used (incidentally further showing the limitations of prior art B-scans as compared to elastograms).

Fig. 5c shows an elastogram corresponding to the B-scan of Fig. 5b, but without any depth correction. Conventionally, the lighter shaded segments of the elastogram represent areas of higher compressibility, and

the darker segments represent areas of lower compressibility. Clearly seen running diagonally through the elastogram is the diagonal seam. Further, this seam correctly shows up as a region of higher compressibility, because the surface along the seam contains a large number of open foam reticules which would be more compressible than the intact closed ones. While this elastogram shows surprising differentiation when compared with the B-scan of Fig. 5b, it is limited by the increasingly darker shading (representing decreasing compressibility) that occurs for segments more distant from the compressor and transducer. This effect arises, as previously noted, due to the assumption of uniform stress distribution made in earlier methods of elastography.

Fig. 5d shows an elastogram corresponding to Figs. 5b and 5c using the depth-correction method described above. Because this method accounts for and factors the variations in stress as a function of depth with the measured strain, the decreasing compressibility seen in Fig. 5c no longer appears in Fig. 5d. Rather, the elastogram of Fig. 5d shows relatively uniform values for compressibility across all depths, as one would expect to find for a body composed of the same material.

A method is also provided, in a presently preferred embodiment of elastography, to correct for artifacts and image deterioration due to aberrations in the target body. Almost all ultrasonic imaging suffers from such artifacts and image deterioration, particularly from aberrations at the body wall. Interspersed layers of fat and muscle, having differing sonic velocities, may interfere with focusing and proper registration of ultrasonic beams.

A presently preferred method of correcting for any such distortions follows an initial determination, according to the elastographic methods already described, of the compressibility of each segment of interest in the target body. These compressibility profiles are then used to identify regions having differing sonic velocities. This identification is preferably computed from the compressibility profiles, but it may be done manually from an elastogram or, when identifying the boundaries of such regions, by a standard B-scan. For example, when dealing with a human body wall it is known that fat is much softer than muscle; this difference should show up clearly on compressibility profiles or elastograms, and either one may be used to identify the fatty versus muscle regions.

Once the regions are identified, a sound "speed map" of the regions of interest is calculated by ascribing the appropriate sonic velocities to the identified regions. For example, it is further known that one may generally ascribe a sonic velocity of about 1450 m/s to fatty regions and about 1580 m/s to muscle. Having identified which regions are fatty and which muscle, and the boundaries of these regions along each echo sequence of interest, a map of the varying sonic velocities along each sonic beam in an array of beams is made. Once the speed map is determined, the times required to traverse the segments along each sonic beam may be calculated and summed, yielding the time required for each echo sequence to traverse the body wall. The appropriate time delays, necessary to correct for variations in echo sequence travel time along different sonic beams through the same distance, are then determined. Finally, these delays are applied to correct each echo sequence and the derived compressibility profiles and elastograms of the target body.

While this method has particular application with respect to correcting distortion and shifts incurred by aberration at a body wall, it should be recognized that it may also be applied to other areas of target bodies, particularly where the varying regions of sonic velocity can be readily identified by initial compressibility profiles or elastograms. This method may be used to clarify both elastograms and sonograms.

Referring now to Fig. 6, an apparatus is shown schematically for determining compressibility of a target body 204 comprising a rigid frame 199; a motor 200 attached to the frame 199; an axial member 201 having a first and second end, the first end being coupled to the rigid frame 199, and the second end being coupled to the motor 200 such that the axial position of the axial member 201 and rigid frame 199 may be varied by operating the motor 200; and an ultrasonic source 202 mounted on the rigid frame 199. The ultrasonic source 202 has a surface 212 capable of being sonically coupled to the target body 204. The target body 204 rests on a support 215.

The ultrasonic source 202 may be a single transducer or a transducer array. The axial member 201 may be a worm gear.

The top surface of a layer 203 with a known elastic modulus and speed of sound may be coupled to the ultrasonic source's 202 lower surface 212. The bottom surface of the layer 203 is coupled to the target body 204.

The apparatus may also contain a data storage medium connected to the transducer for storing signals from the transducer. The movement of the axial member 201 may be

controlled in precise amounts by using a motor controller 205 connected to the motor 200, such that operation of the motor 200 moves the axial member 201 in precise amounts.

5

A transmitter 206 may be connected to the ultrasonic source 202 to energize the ultrasonic source 202. A receiver 207 may also be connected to the ultrasonic source 202 such that signals generated by the ultrasonic source 202 in response to echo sequences are transmitted to the receiver 207. A digitizer 209 may be connected to the receiver 207 to convert analog signals into numerical data. Furthermore, a cross-correlator 210 may be connected to the digitizer 209. A computer 208 may be connected to the transmitter 206 such that the computer 208 is capable of triggering the transmitter 206. Also, the cross-correlator 210 may be connected to the computer 208 such that data may be received by the computer 208. In a preferred embodiment, the cross-correlation may be accomplished by using a software program instead of a hardware cross-correlator 210, such that the cross-correlation algorithms discussed above may be implemented, by any well-known programming technique. The computer 208 may be programmed to convert the numeric data, representing echo sequences, into strain or compressibility data or into a strain or compressibility profile. Images of the strain profile and the compressibility profile may be displayed on a monitor 211 connected to the computer 208.

20
25
30

It will be noted that the motor controller 205 and motor 200 may be rigidly connected to additional structure, such that ultrasonic source 202 may only be moved as the axial number 201 or additional structure is moved. It will also be noted that the portion of the apparatus including the motor controller 205, motor 200,

35

axial number 201, rigid frame 199 and ultrasonic source 202 may be hand held, where the motor 200 may still axially move the axial member 201 and ultrasonic source 202 while said portion of the apparatus is being held in a hand against the target body 204.

Further, instead of being in a handheld device, the ultrasonic source 202 may be enclosed in any convenient means, such as a balloon, for insertion inside target bodies. This latter apparatus would have particular application in examinations for diseases such as prostate cancer, which may not appear clearly on normal sonograms. In such an application, the ultrasonic source 202 may be attached to a flexible control cable and surrounded by a balloon. The balloon and ultrasonic source 202 may then be inserted into the rectum, with the flexible control cable connecting the ultrasonic source to the portion of the apparatus remaining outside of the body. A fluid may then be used to inflate the balloon inside the rectum, and to further inflate the balloon to compress against the walls of the intestinal tract. A means for rotating the ultrasonic source 202 inside the balloon may also be used for positioning the ultrasonic source to insonify particular tissues of interest, such as the prostate, within the body. Pre- and post-compression echo sequences may then be made and analyzed by the computer to determine the strain profile for the tissue of interest. Further, a compliant body of known elasticity may be disposed such that it is compressed between the balloon and the intestinal wall, allowing the stress from the compression to be estimated and a compressibility profile to be determined.

Although elastography has been described in relation to clinical diagnosis above, this should be understood not to be a limiting factor on the utility of

elastography. For example, elastography may be used in forensics, tissue characterization studies, veterinary medicine, laboratory experiments, and industrial applications. Also, the present techniques may be employed to any materials that are capable of being physically compressed or displaced; that is, a material which is internally displaceable in response to pressure applied to the material.

The various aspects of elastography will appear more specifically in the following examples that are purely illustrative and should not be construed to limit the scope of the invention. These examples are based on experiments performed to corroborate the basic elastographic method. All experiments were performed in a 120 gallon water tank on synthetic foam blocks and tissues *in vitro*. The experimental setup included a system controlled by a Compaq 386 computer via an IEEE 488 bus. A stepper motor controller (made by Superior Electric Co.) enabled transducer movements in steps of 2.5 microns. A transmitter (made by Metrotek Corp.) was used to shock excite the transducer. The received signal was amplified by an input protected, TGC controllable amplifier, and fed into an 8 bit digitizer operating at 50 MHz (made by LeCroy Corp.). The Compaq computer was used to compute the digitized data, using a program, written using ordinary program techniques, which included routines which substantially implemented the cross-correlation algorithm disclosed in *Boucher et al., supra*. A NEC monitor with a 256 gray shade scale display was used to display the A-lines, B-lines and elastograms. All experiments were performed using a 2.25 Mhz, 19 mm diameter transducer focused from 7-19 cm.

EXAMPLE 1: Measurement of elastic modulus of foam blocks

Three types of reticulated open cell polyester foam samples were cut into 14 X 14 X 5 cm blocks. Type I was a black foam with a porosity of ~ 80 ppi (pores per
5 inch). Type II was a fellow foam with a porosity of ~ 30 ppi. Type III was a coarse black foam with a porosity of ~ 20 ppi. The foam blocks were immersed in a beaker containing distilled water and a small amount of a
10 surfactant (by Bath-kleer, Instrumentation Laboratories, Lexington, MA). The foam blocks were then degassed under laboratory vacuum (~ 0.5 bar) for approximately 30 minutes, and then transferred to a large water tank maintained at 21 ± 1 °C. The elastic modulus of each
15 foam block was determined by uniformly loading the top of the foam with 6 premeasured lead weights with masses of 50, 100, 150, 200 250, and 300 grams. The resultant compression of the foam was measured from the difference between the times of flight of an ultrasonic pulse to and
20 from a reference plane before and after loading. The elastic modulus of each foam block was calculated from the mean of their respective stress/strain data obtained for the above mentioned loads.

The elastic moduli values were calculated for
25 compression only and not for expansion. The resulting mean values of the elastic moduli for foam Type I was ~ 23 kPa; for foam Type II it was ~38 Kpa; and for foam Type III it was ~ 21 kPa. The standard deviation in these measurements was on the order of $\pm 20\%$. The inverse
30 elastic moduli values in the three foam blocks were 0.043, 0.026, and 0.048 kPa^{-1} , respectively.

Example 2: Measurement of axial stress uniformity

A block of Type III foam was degassed and immersed
35 in the water tank at room temperature. An annular plexiglas plate was attached to the transducer. The flat

surface of the transducer aperture formed a part of the compressor, whose size could be changed by using a different size annulus. Annuli were made with outer diameters (o.d.) of 44, 89 and 127 mm. For each annulus,
5 the strain profile in the foam in response to a 1 mm compression was measured.

As mentioned earlier, the extension of the 1-dimensional model to the 3-dimensional case involves
10 assumption of uniform axial stress field. However, this assumption is strictly valid only for infinitely large compressors. The theoretical behavior of the axial stress as a function of the quantity (z/a) , the ratio between the axial distance from the compressor aperture
15 and the radius of the circular compressor, has been discussed above. This behavior is likely to become important for large values of (z/a) . But, for ratios of $z/a \leq 1$, a relatively modest and gradual decline in the axial stress occurs, which could be either ignored or
20 corrected for, as needed.

Since it was not feasible to make direct localized stress measurements, the axial distribution of strain was measured instead and assumed to be proportional to
25 stress. The results of the axial strain in foam Type III is shown in Fig. 3a for a 127 mm compressor. Similar axial strains were taken for 44 and 89 mm compressors. From these experiments it became clear that the general behavior of the strain follows the theoretical
30 predictions reasonably well.

Example 3: Elastography in phantoms

Three foam phantoms were used to demonstrate the capabilities of elastography. The first phantom
35 consisted of an 11 degree, 140 mm long wedge of foam Type I surrounded by blocks of foam Type II. The bottom part

of the phantom was made of foam Type I. The second phantom consisted of two nearly identical triangular foam pieces obtained by diagonally cutting a square foam block of Type III and then tightly rejoining the cut pieces.

5 The third phantom consisted of a 38 mm thick horizontal layer of foam Type I embedded between two foam blocks of Type II.

The elastography experiments were conducted by using the 127 mm o.d. annulus. The compressor was put in contact with the phantom and one A-line was taken. The compressor was then moved axially downward by 1.00 mm, and a second A-line was taken. The compressor was then lifted by several millimeters to clear the phantom, and

10 moved laterally by 1 or 2 mm. The process was then repeated, until 40-60 A-line pairs were collected from a 40-120 mm wide region.

The A-line pairs were then cross-correlated and a strain image of the wedge phantom made, in which the wedge was clearly visualized. A "B-scan" was also constructed from the same raw data, but this B-scan yielded speckle and poor visibility of the wedge. Next, an elastogram of the wedge was derived from the strain

15 image. The gray levels in the elastogram were calibrated in kPa^{-1} units, and were derived from the strain image by estimating the average strain in the first 5 mm of the known anterior foam material. This strain was multiplied by the known elastic modulus of the first layer, and the

20 resulting stress was assumed to be the stress applied to the system.

Similarly, a strain image of the second phantom, consisting of two triangular foam pieces and shown in

25 Fig. 5a, was made. The seam between the foam pieces was clearly visible. The "B-scan" derived from the same

data, shown in Fig. 5b, produced an image where the seam
in the foam was completely invisible. Fig. 5c shows the
corresponding elastogram, and Fig. 5d shows the
elastogram after the application of correction for depth
dependent stress.

The phantom images reveal several interesting and
potentially useful characteristics of elastography. The
strain image of the second phantom demonstrated that the
background texture of the image tends to be much more
uniform than a "B-scan" due to the apparent lack or
diminution of speckle. Speckle is a known artifact which
is present in all ultrasound B-scans, and which limits
the attainable image quality. This strain image also
demonstrated the sensitivity of elastography, where the
thin region along the cut surfaces of the two foam blocks
shows up clearly against the background. Evidently,
cutting the foam results in severed and disrupted foam
reticules. As a result, the region near the cut surface
would be expected to contain a large percentage of open
reticules which would be more compressible than the
intact closed ones. By comparison, the "B-scan" image of
the same structure shown in Fig. 5b is dominated by
speckle and does not show the seam in the foam block,
since the backscatter characteristics of the seam remain
unchanged. Another result is the apparent good lateral
resolution along the whole range from the face of the
transducer, as demonstrated by the relatively uniform
thin line representing the image of the seam. Since the
transducer focal region extended from 7 to 19 cm, part of
the phantom was in the near zone of the transducer and
thus a significant broadening of the seam image would
have been expected at close ranges. Fig. 5c shows a
quantitative elastogram, where the slight vertical
streaks are artifacts due to uncertainty in the
estimation of the strain in the proximal 5 mm foam layer.

Fig. 5d shows the effect of the theoretical correction for circular compressors, based on Saada's derivation, discussed above.

5 The strain image of the wedge phantom showed that
the compressibility in the wedge was higher than that in
the surrounding material. The increased compressibility
along the cut wedges of the foam pieces was also
demonstrated as an enhanced outline of the wedge. The
10 corresponding "B-scan" showed a mottled appearance of the
wedge, which was again dominated by speckle. It is worth
noting that, in general, the wedge need not be visible on
the "B-scan" in order to give a good elastogram (as was
seen by the case of the diagonal seam in the second
15 phantom). The fact that the backscatter from the wedge
material is higher than that of the surround was
fortuitous. The corresponding elastogram of the wedge
demonstrated the ability of the technique to generate
quantitative images of the elastic modulus distribution
20 in the target. Similar images may be especially useful
for diffuse disease in humans, where hardening or
softening of whole organs would result in overall
quantitative brightness changes in the image. The strain
image of the third phantom showed a clear delineation and
25 an excellent ability to visualize a 6 dB change in the
elastic modulus of the soft middle layer, reduction of
speckle, and the cut edge softening effect. The
corresponding "B-scan" showed speckle and poor visibility
of the layer.

30

Example 4: Elastography in a bacon slab

A commercial vacuum-packed slab of bacon was tested in the water tank at 30 ± 0.5 °C. The transducer was used along with an 89 mm annulus. Slight
35 precompression was used in order to ensure right contact
between the compressor and the top surface of the slab.

This was followed by a 0.5 mm compression along 40 parallel axial directions laterally separated by 1 mm. The resulting echo sequences were converted into digital data, processed by the computer, and displayed on the NEC
5 monitor both as a standard B-mode image and as a strain image. Because of the relatively small z/a ratio (≤ 1), no correction for depth dependent stress distribution was applied.

10 The images of the bacon slab demonstrated that the principles of elastography can be practiced on biological tissues as well. Bacon is a good example, since fat is known to be generally softer than muscle. The strain
15 image showed at least two dark (hard) layers in the proximal half of the image which probably correspond to the muscle layers in the specimen. The distal half of the image tends to indicate softer fatty structures. It was noted, however, that different fat layers in the slab
20 appeared to possess varying degrees of compliance. The corresponding B-mode image was quite difficult to interpret.

These experiments are illustrative of, and should not be taken as limitations on, an apparatus and method
25 of elastography. Thus, for example, it is noted that 8-bit digitizers are not required in elastography, as signals with more or less than 8 bits may be used. Similarly, digitizers may operate at frequencies other than 50 MHz, and have been operated as high as 200 MHz
30 with elastography, with the well-known trade-off of more precision in the data versus larger sample data sizes as the frequency increases. Further, transducers other than 2.25 MHz transducers have been utilized, and in
35 particular, 3.5 MHz and 5 Mhz transducers have been utilized and observed to yield more precise data than the 2.25 MHz transducer used in the above experiments.

It will be recognized that elastography may be practiced and modified in many ways. For example, it is well known that ultrasonic transducers are available in matched sets wherein a plurality of matched transducers
5 are assembled side-by-side in a single head. It is contemplated that such multi-channel arrays may be coupled to an animal tissue or other compressible solid material, and that multiple ultrasonic signals may
10 thereby be transmitted into the material simultaneously along an array of radiation axes. Thus, an entire section of the material may be examined by using such an array. Images of strain and/or elastic modulus may be made.

15 It will also be recognized that one transducer may be used as a transmitter and that one or more transducers may be offset from the transmitter and used as receivers.

20 While elastography has been shown in connection with certain presently preferred embodiments thereof, those skilled in the art will recognize that many modifications may be made therein without departing from the true spirit and scope of the invention. Accordingly, it is
25 intended that the following claims cover all equivalent modifications and variations as fall within the spirit and scope of the invention.

Throughout this specification and the claims which follow, unless the context requires otherwise, the word "comprise", or variations such as "comprises" or "comprising", will be understood to imply the inclusion of a stated integer or group of integers but not the exclusion of any other integer or group of integers.



THE CLAIMS DEFINING THE INVENTION ARE AS FOLLOWS:

1. A method of estimating compressibility of a target body, the method including the steps of:

5 (a) sonically coupling an ultrasonic source to said target body;

(b) emitting a first pulse of ultrasonic energy from the source along an axis in said target body;

10 (c) detecting the arrival time of a first echo sequence having at least one echo segment arriving in response to said first pulse of ultrasonic energy;

(d) transaxially moving the ultrasonic source so as to compress said target body;

15 (e) emitting a second pulse of ultrasonic energy from the source along said axis in the target body following said movement;

20 (f) detecting the arrival time of a second echo sequence having at least one echo segment, being congruent with at least one said echo segment having arrived in response to said first pulse, arriving in response to said second pulse of ultrasonic energy;

(g) measuring the differential displacement of a plurality of said congruent echo segments;

25 (h) calculating the strain along said axis following said movement;

(i) measuring the stress imparted along said axis as a result of said movement by:

30 (1) measuring the shape and area of the ultrasonic source, including any compressor attachments, compressing against the target body;

35 (2) determining a profile of variations in stress along said axis from the position along said axis and said shape and area of the source; and

(3) calculating a corrected stress along said axis by applying said profile to said measured stress; and

5 (j) dividing the strain along said axis by the stress along said axis.

2. A method according to claim 1 wherein in steps (b) and (e) a plurality of said first and second pulses are emitted
10 along a corresponding plurality of axes into the target body, and steps (c), (d), and (f) through (j) are performed for each said first and second pulses.

3. A method according to claim 2 further comprising the
15 steps of

(a) identifying regions along said axes having different sonic speeds from the determined values of compressibility;

(b) determining the time required for said pulses and
20 echo sequences to traverse said regions along said axes;

(c) determining correction time delay factors for correcting variations in echo sequence travel time arising from variations in sonic speed in the target body; and

(e) applying said time delay factors to said echo
25 sequences for correcting said substantial variations.

4. A method substantially as hereinbefore described with reference to the accompanying drawings.
30

DATED this 31st day of March, 1995

Board of Regents, The University of Texas System

35 By Its Patent Attorneys

DAVIES COLLISON CAVE



1/8

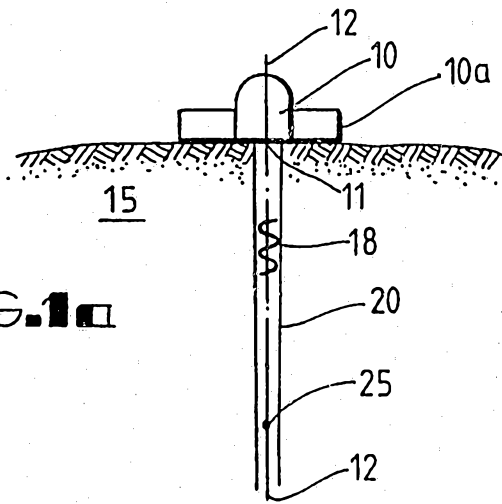

FIG. 1a

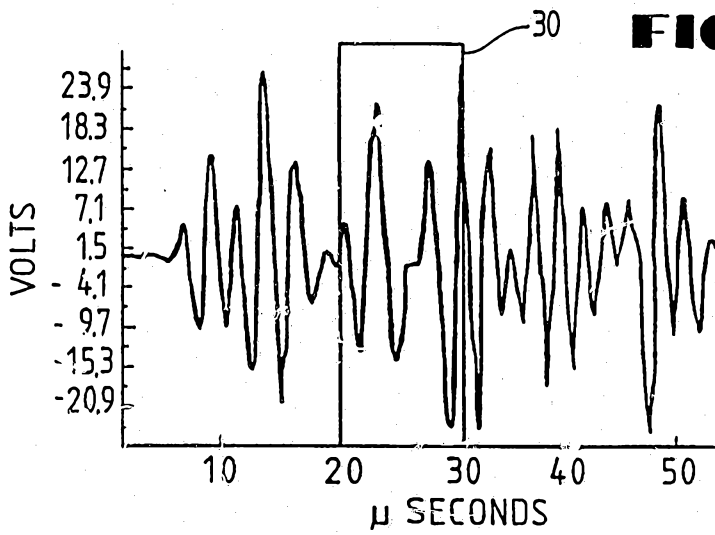

FIG. 1b

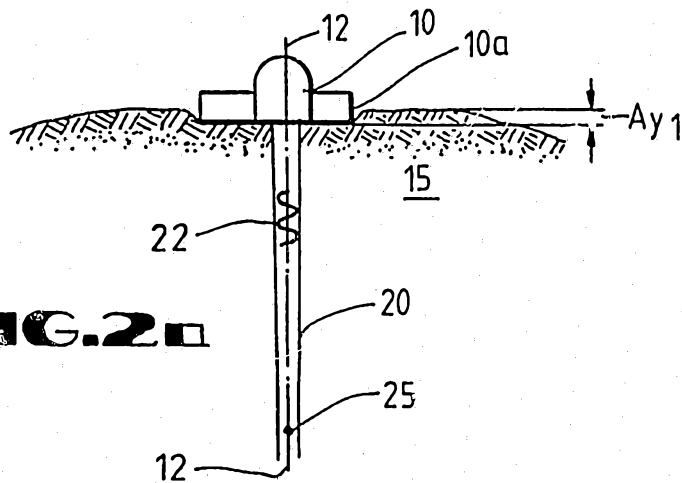
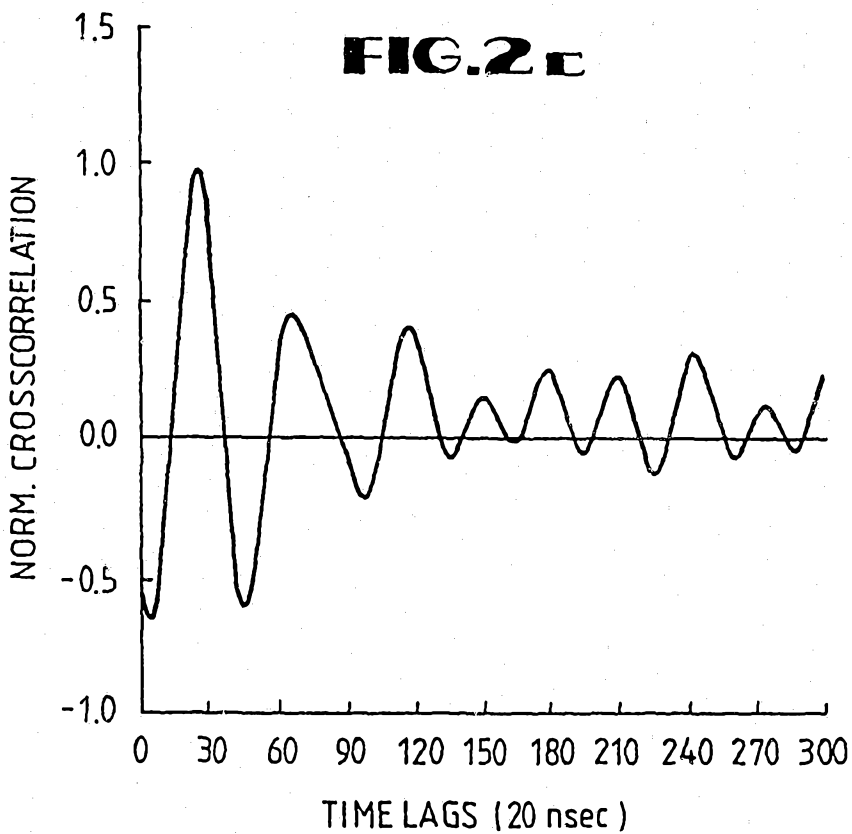
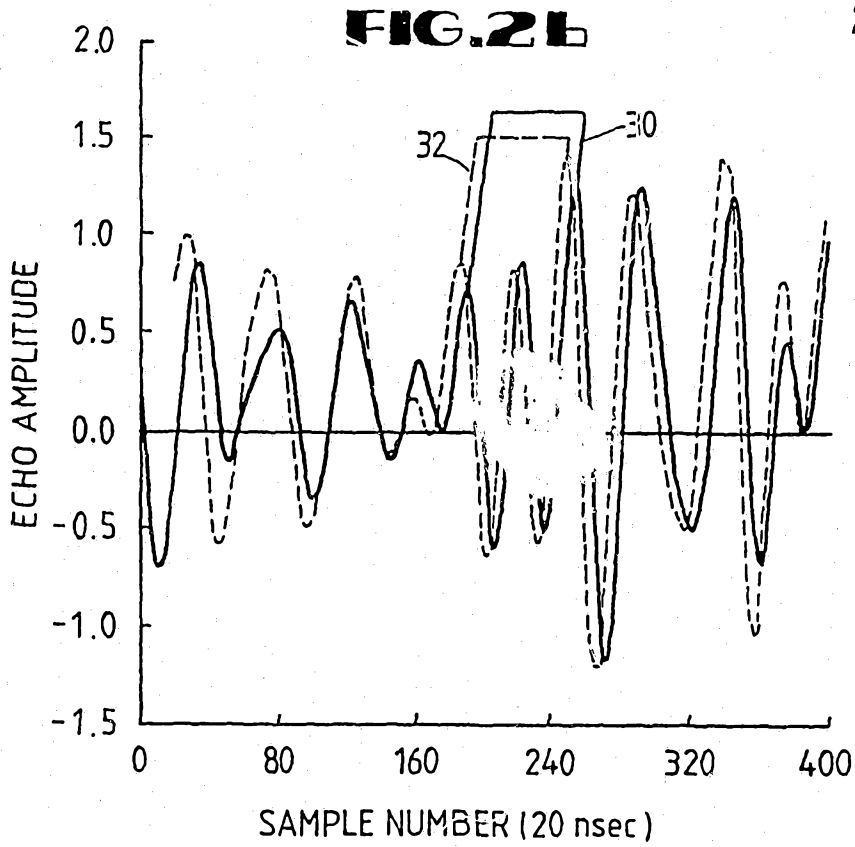

FIG. 2a



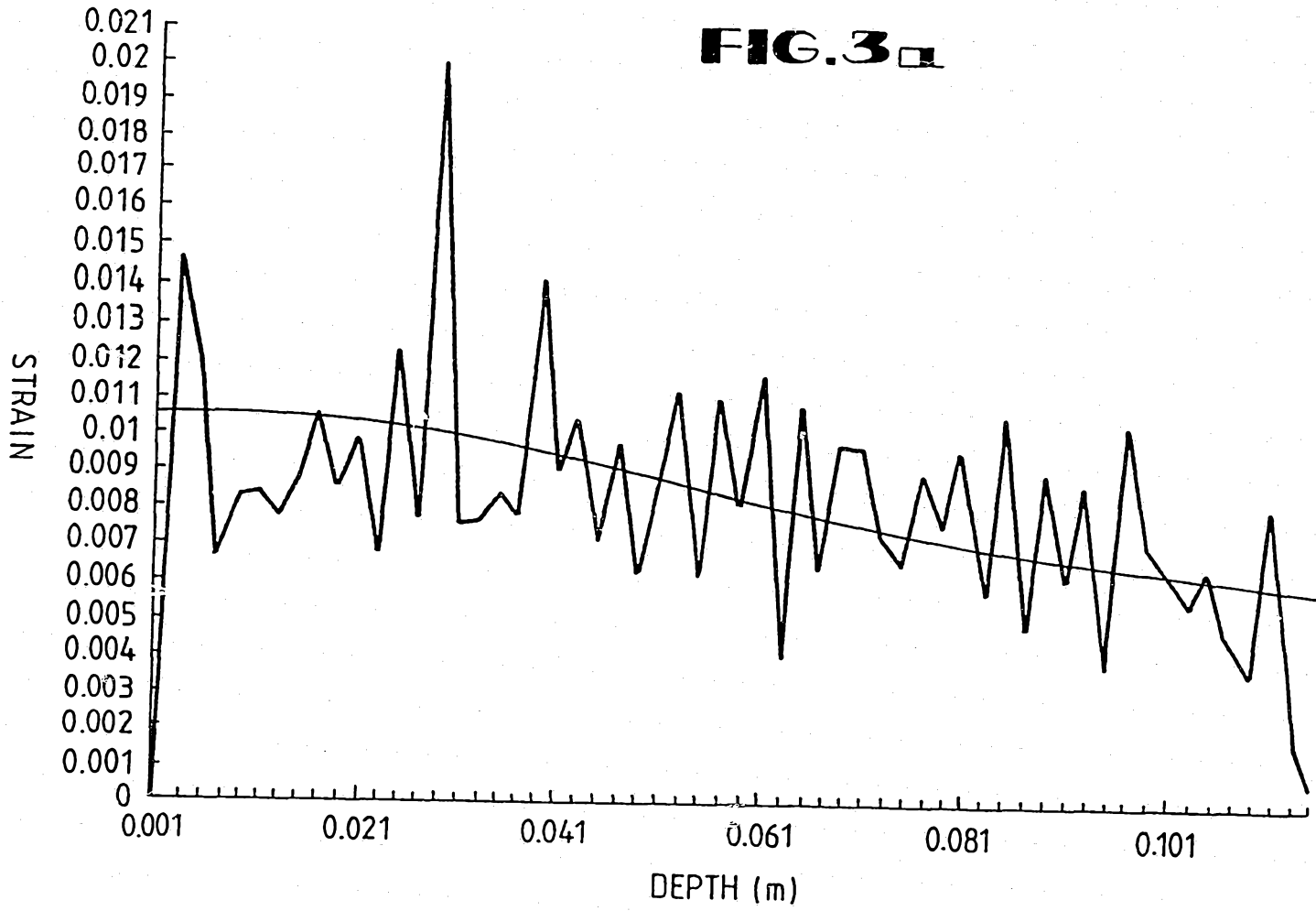

FIG. 3b

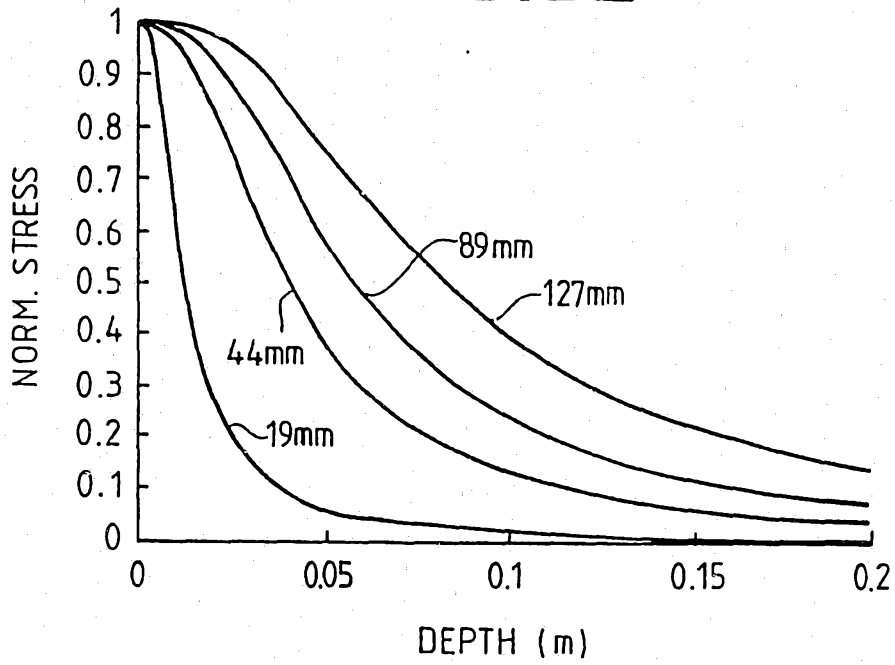
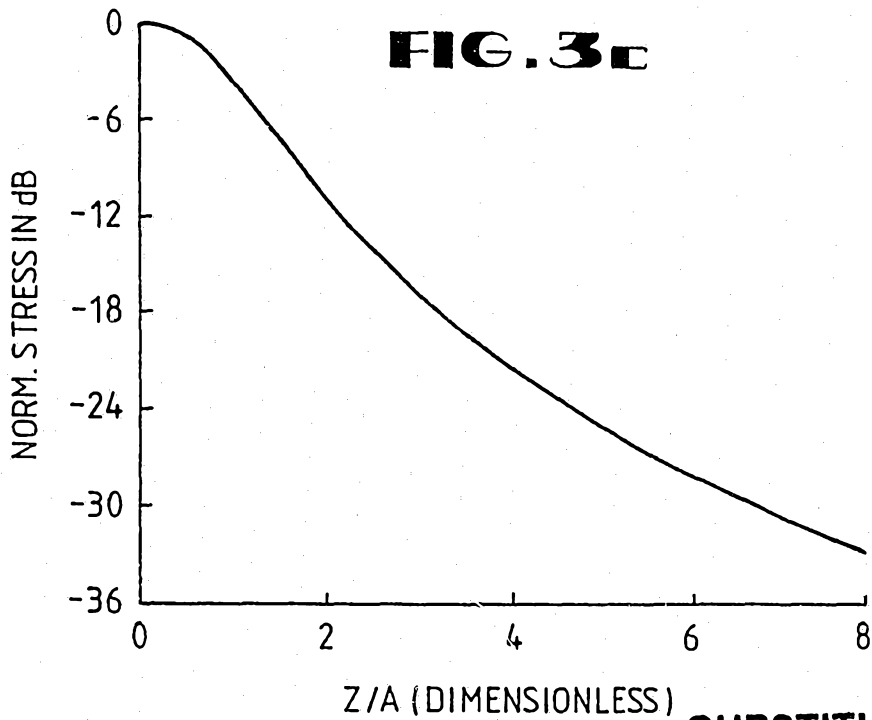

FIG. 3c



SUBSTITUTE SHEET

5/8

FIG. 4A

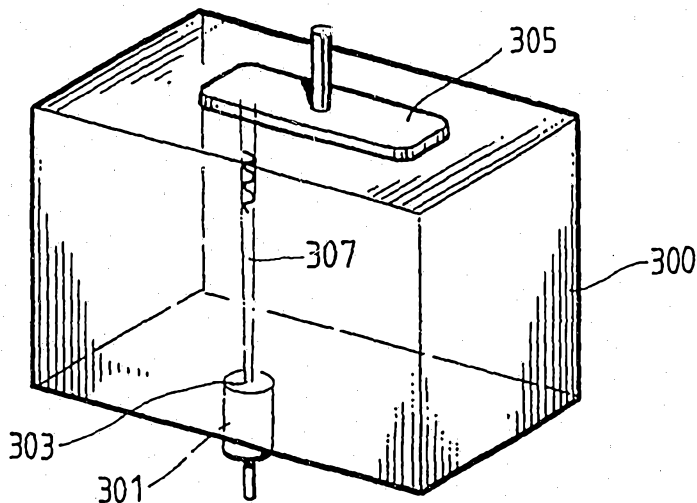
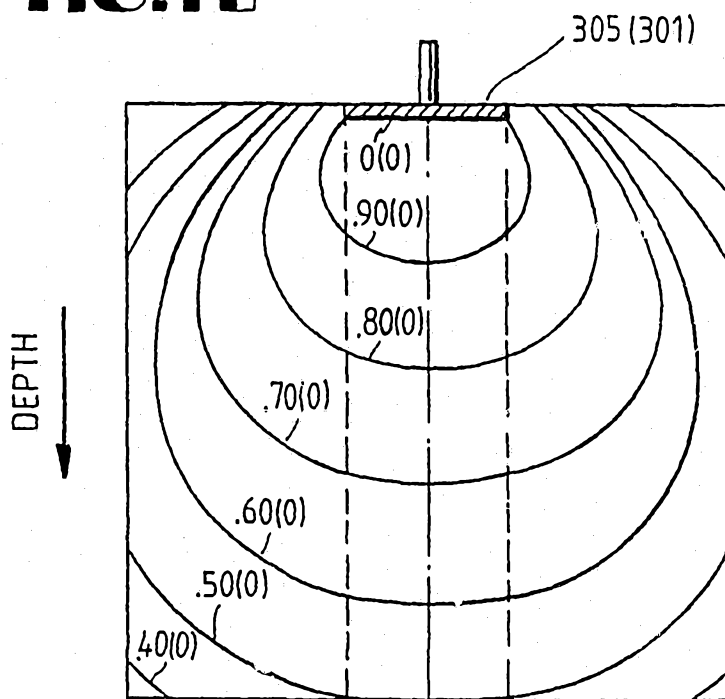

FIG. 4B



SUBSTITUTE SHEET

FIG. 5a

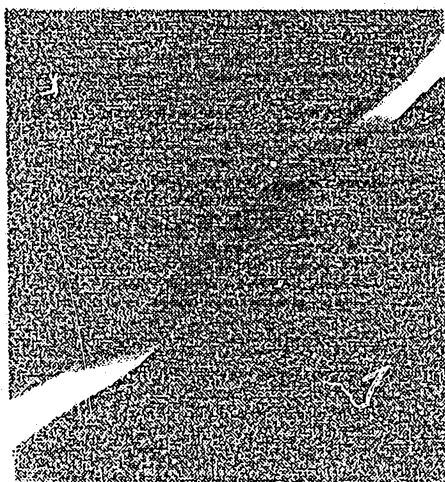
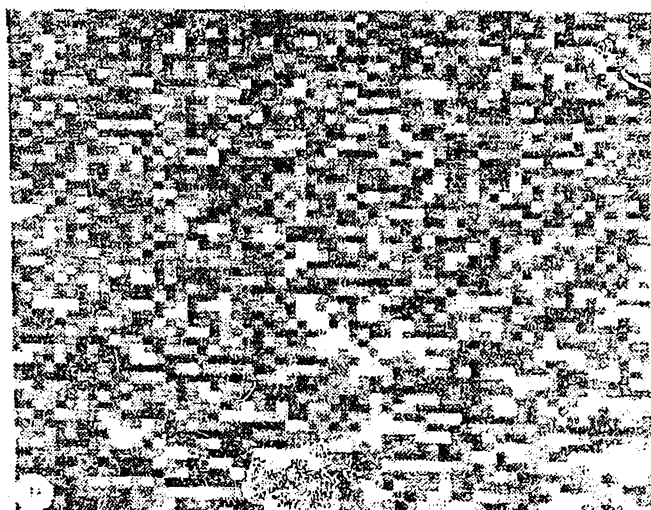

FIG. 5b



SUBSTITUTE SHEET

7/8

FIG. 5e

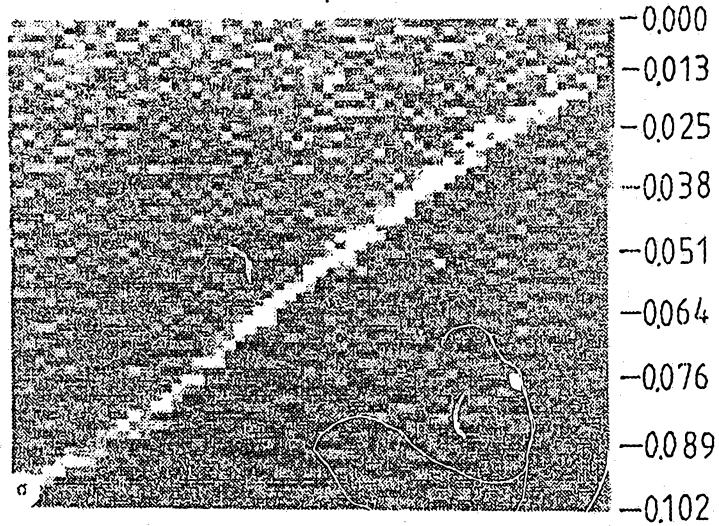
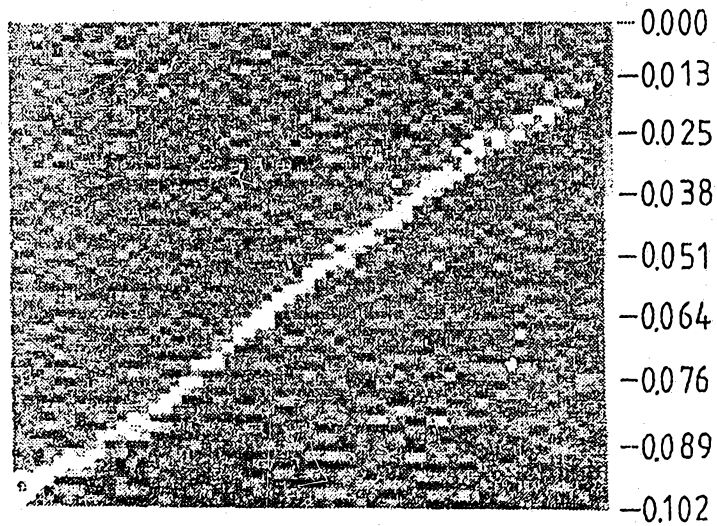

FIG. 5d



SUBSTITUTE SHEET

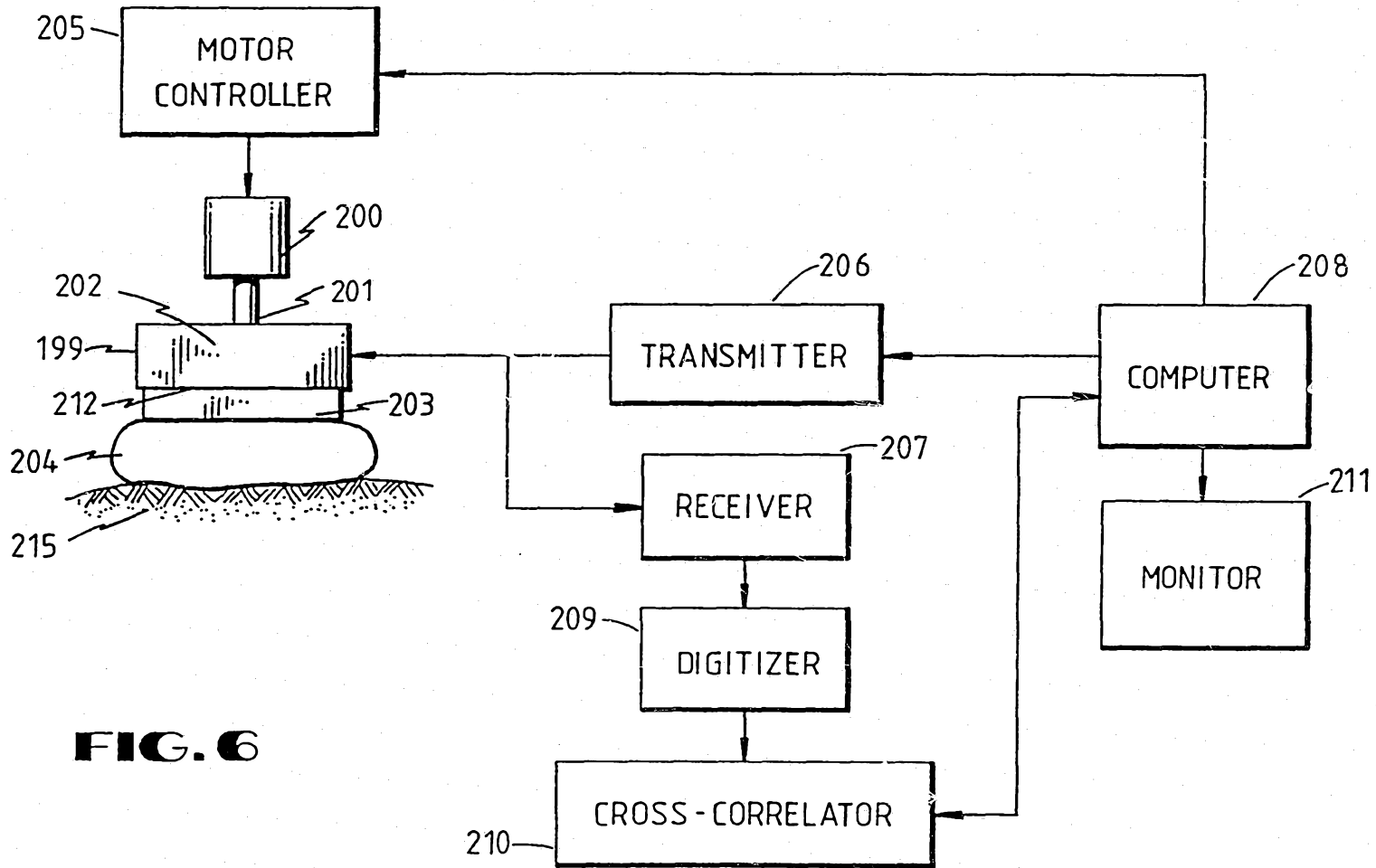

FIG. 6

INTERNATIONAL SEARCH REPORT

International Application No

PCT/US 92/03856

I. CLASSIFICATION OF SUBJECT MATTER (If several classification symbols apply, indicate all) ⁶		
According to International Patent Classification (IPC) or to both National Classification and IPC Int.Cl. 5 G01N29/18; G01S15/89; G01N29/10		
II. FIELDS SEARCHED		
Minimum Documentation Searched ⁷		
Classification System	Classification Symbols	
Int.Cl. 5	G01N ; G01S	
Documentation Searched other than Minimum Documentation to the Extent that such Documents are Included in the Fields Searched ⁸		
III. DOCUMENTS CONSIDERED TO BE RELEVANT⁹		
Category ¹⁰	Citation of Document, ¹¹ with indication, where appropriate, of the relevant passages ¹²	Relevant to Claim No. ¹³
P, A	WO, A, 9 107 657 (BOARD OF REGENTS, THE UNIV. OF TEXAS SYSTEM) 30 May 1991 see the whole document -----	1-18
A	EP, A, 0 329 817 (INSTITUTE OF BIOLOGICAL PHYSICS OF THE USSR ACADEMY OF SCIENCE) 30 August 1989 see the whole document -----	1
A	JAPANESE JOURNAL OF APPLIED PHYSICS vol. 23, no. 23-1, 1984, TOKYO JAPAN pages 66 - 68 I.HATTA ET AL.: 'Ultrasonic elastic constants of Muscle' see the whole document -----	1
<p>¹⁰ Special categories of cited documents:</p> <p>"A" document defining the general state of the art which is not considered to be of particular relevance</p> <p>"E" earlier document but published on or after the international filing date</p> <p>"L" document which may throw doubts on priority claim(s) or which is cited to establish the publication date of another citation or other special reason (as specified)</p> <p>"O" document referring to an oral disclosure, use, exhibition or other means</p> <p>"P" document published prior to the international filing date but later than the priority date claimed</p> <p>"T" later document published after the international filing date or priority date and not in conflict with the application but cited to understand the principle or theory underlying the invention</p> <p>"X" document of particular relevance; the claimed invention cannot be considered novel or cannot be considered to involve an inventive step</p> <p>"Y" document of particular relevance; the claimed invention cannot be considered to involve an inventive step when the document is combined with one or more other such documents, such combination being obvious to a person skilled in the art.</p> <p>"&" document member of the same patent family</p>		
IV. CERTIFICATION		
Date of the Actual Completion of the International Search	Date of Mailing of this International Search Report	
22 SEPTEMBER 1992	08. 10. 92	
International Searching Authority	Signature of Authorized Officer	
EUROPEAN PATENT OFFICE	KOUZELIS D.	

**ANNEX TO THE INTERNATIONAL SEARCH REPORT
ON INTERNATIONAL PATENT APPLICATION NO. US 9203856
SA 60759**

This annex lists the patent family members relating to the patent documents cited in the above-mentioned international search report. The members are as contained in the European Patent Office EDP file on
The European Patent Office is in no way liable for these particulars which are merely given for the purpose of information. 22/09/92

Patent document cited in search report	Publication date	Patent family member(s)	Publication date
WO-A-9107657	30-05-91	US-A- 5107837	28-04-92
		AU-A- 6965091	13-06-91
		EP-A- 0500801	02-09-92
EP-A-0329817	30-08-89	AU-A- 3000089	24-08-89
		CN-A- 1036505	25-10-89
		JP-A- 2021840	24-01-90
		US-A- 4947851	14-08-90