

(12) UK Patent Application (19) GB (11) 2 294 170 (13) A

(43) Date of A Publication 17.04.1996

(21) Application No 9515583.4

(22) Date of Filing 28.07.1995

(30) Priority Data

(31) 06229164 (32) 26.09.1994 (33) JP

(71) Applicant(s)

Fujitsu Limited

(Incorporated in Japan)

1015 Kamikodanaka, Nakahara-ku, Kawasaki-shi,
Kanagawa 211, Japan

(51) INT CL⁶

H04B 10/17

(52) UK CL (Edition O)

H4B BK16D

(56) Documents Cited

GB 2280561 A GB 2257320 A GB 2243942 A
EP 0617527 A1 EP 0508880 A1 EP 0508149 A
EP 0440024 A

(58) Field of Search

UK CL (Edition O) H1C CBAA , H4B BK16 BK16D
INT CL⁶ H01S , H04B

(72) Inventor(s)

Kazuo Yamane
Michikazu Shima
Yumiko Kawasaki
Kenichi Tagawa
Shinya Inagaki
Norifumi Shukunami

(74) Agent and/or Address for Service

Haseltine Lake & Co
Hazlitt House, 28 Southampton Buildings, Chancery
Lane, LONDON, WC2A 1AT, United Kingdom

(54) Optical amplification of wavelength-division-multiplexed signals

(57) An optical amplifier, for amplifying a wavelength-division-multiplexed optical input signal composed of optical signals having different wavelengths, is provided with means (25) for controlling its output level according to the number of the optical signals, to optimize the output level of each of the optical signals. If the number of optical signals is two, the difference between the respective gains of the amplifier for the two optical signals is reduced by simultaneous excitation of a doped optical fibre, in the amplifier, by two different excitation beams.

Fig.12

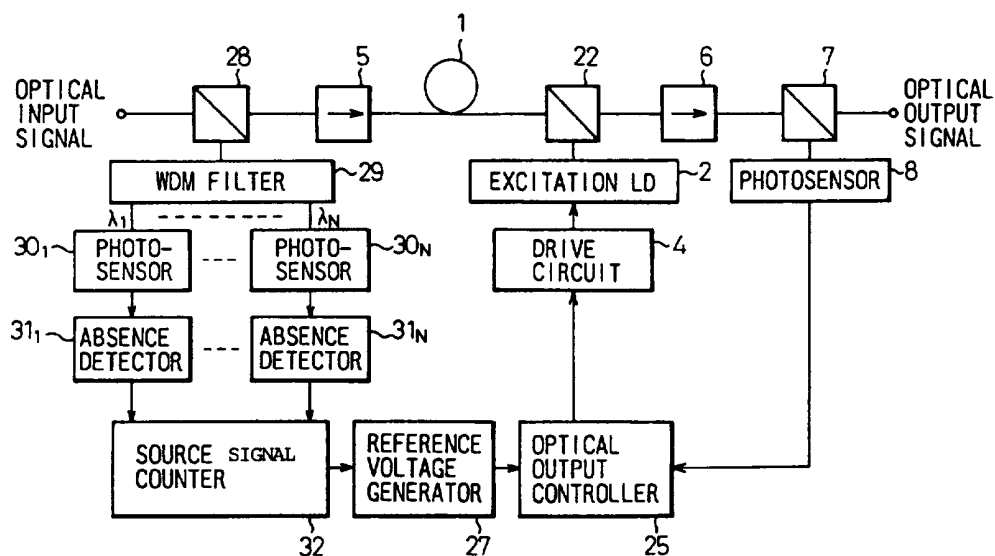

GB 2 294 170 A

Fig.1

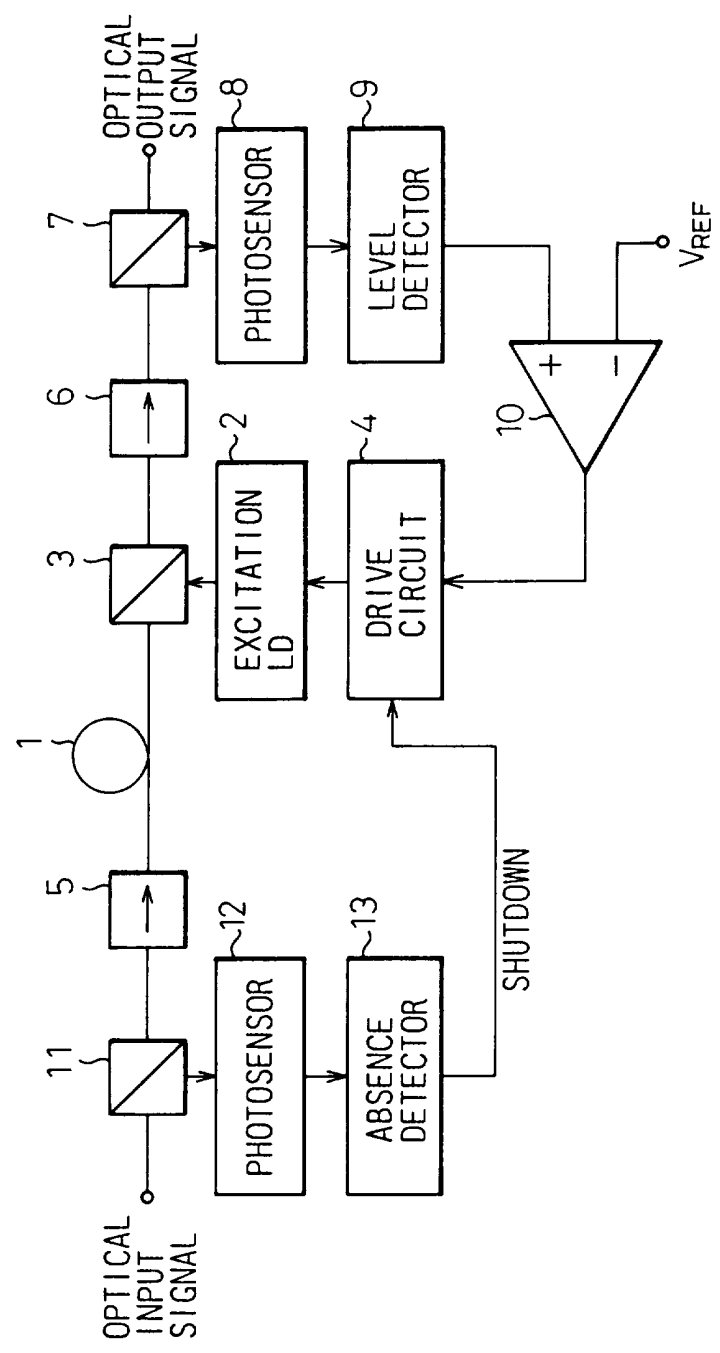

Fig. 2

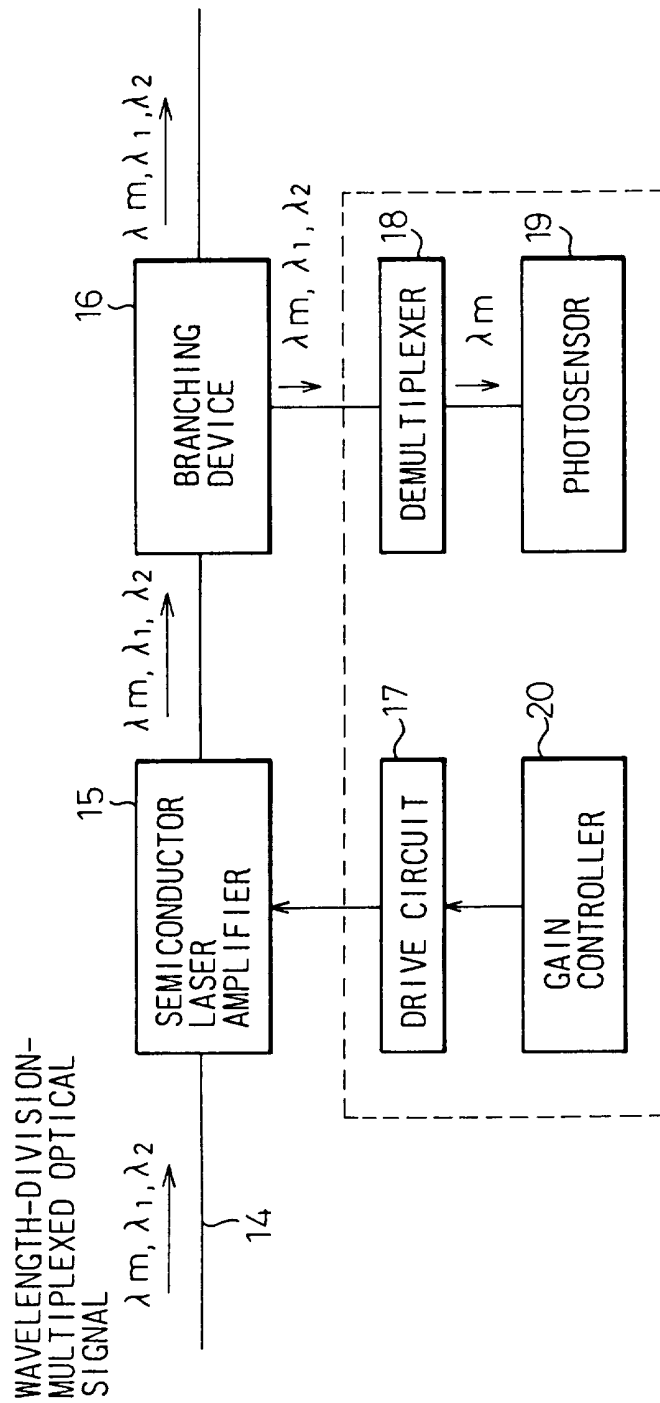

Fig. 3

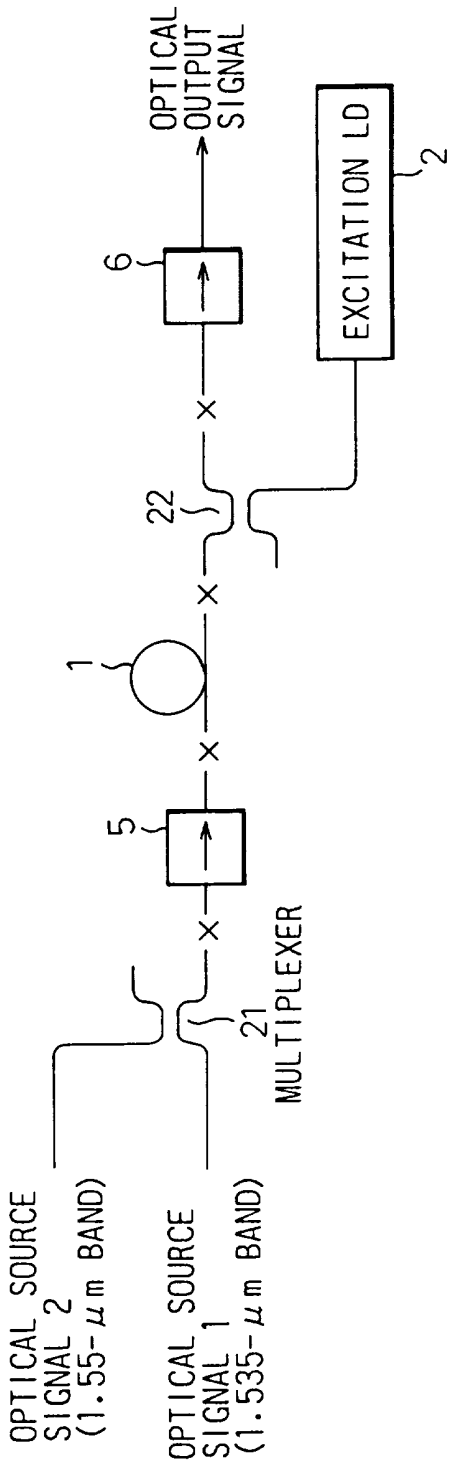

Fig. 4(a)

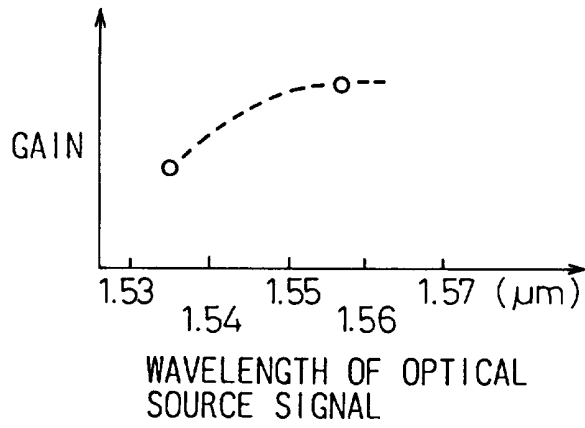

Fig. 4(b)

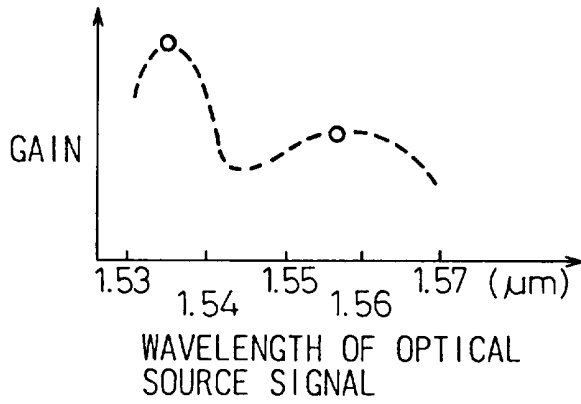

Fig. 5

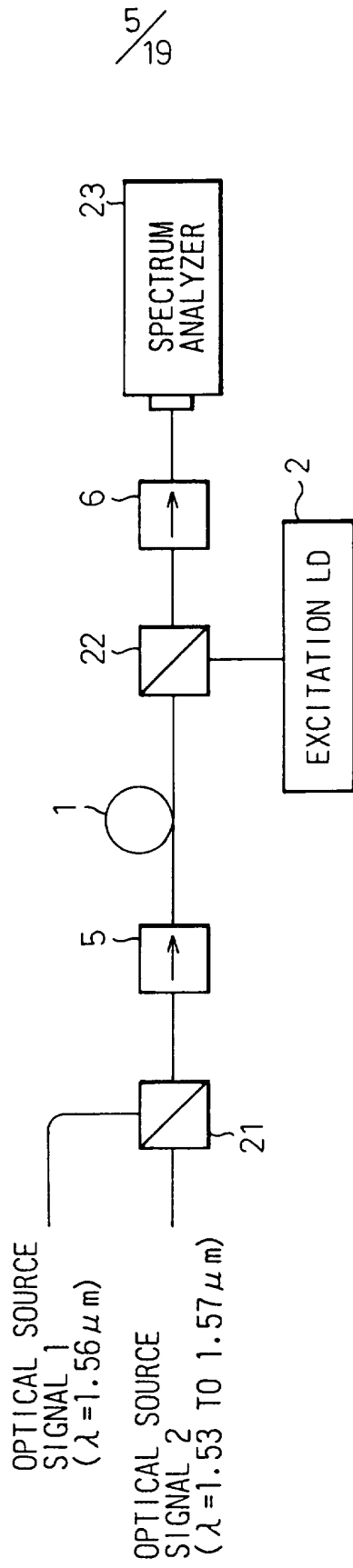

Fig.6(a)

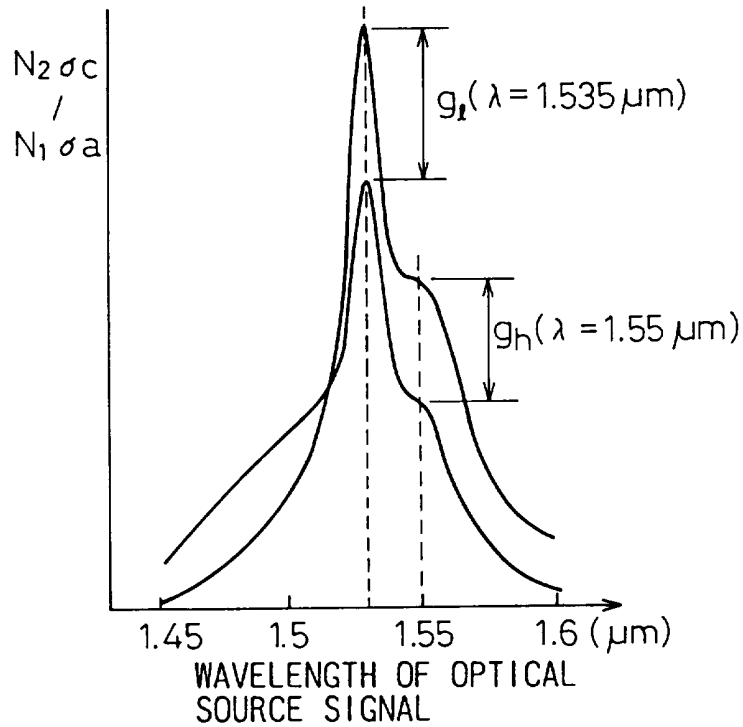

Fig.6(b)

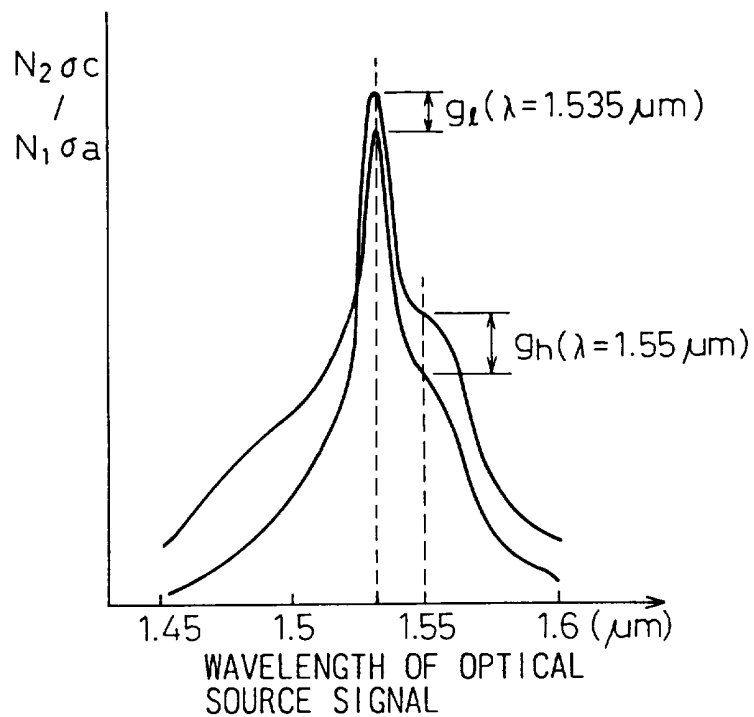

Fig.7

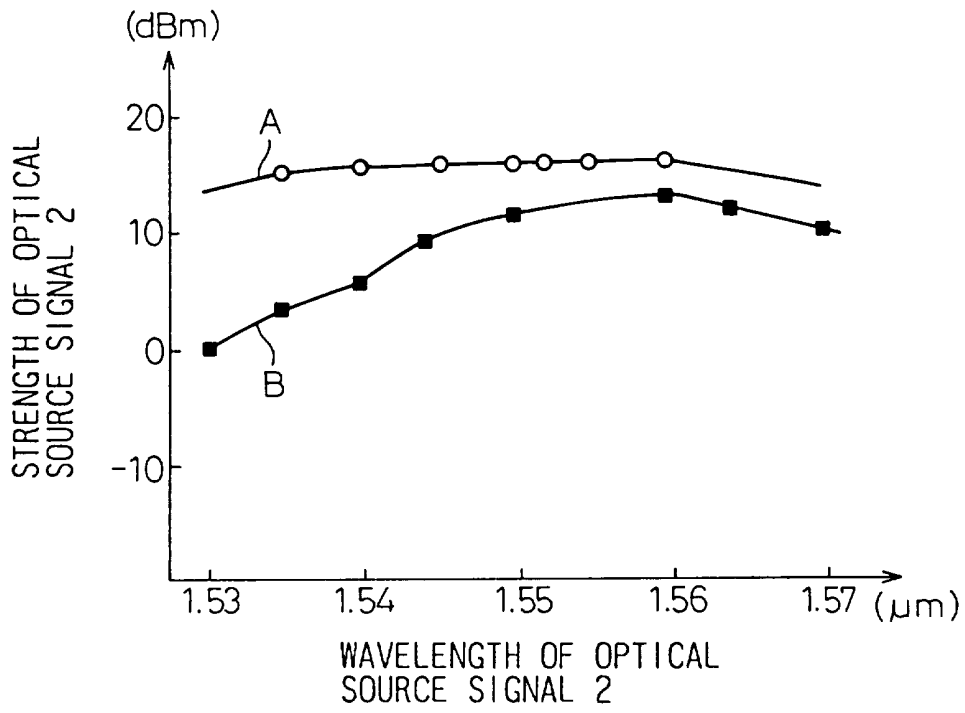

Fig.8(a)

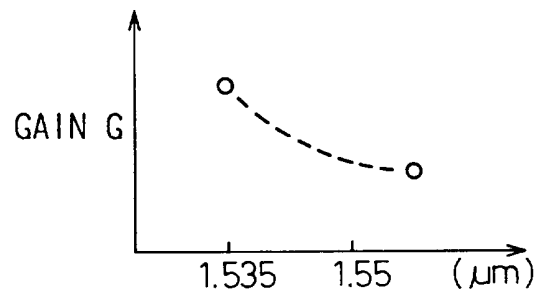

Fig.8(b)

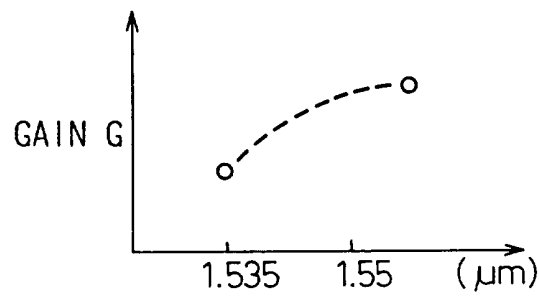

Fig.9

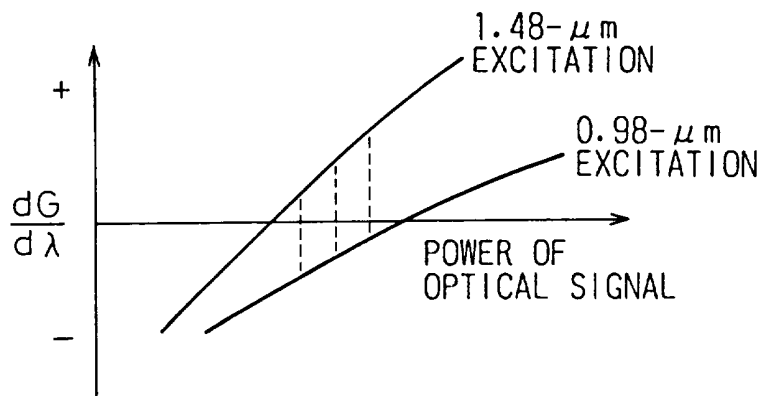

Fig.10

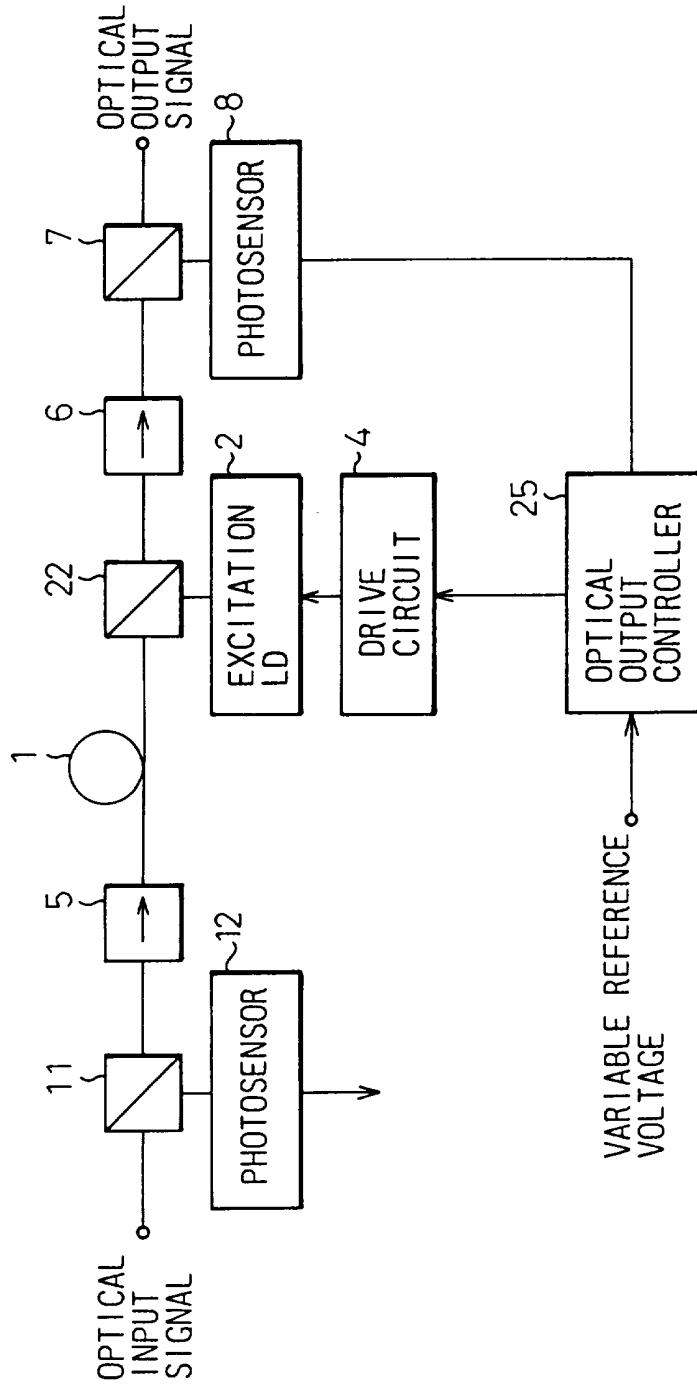
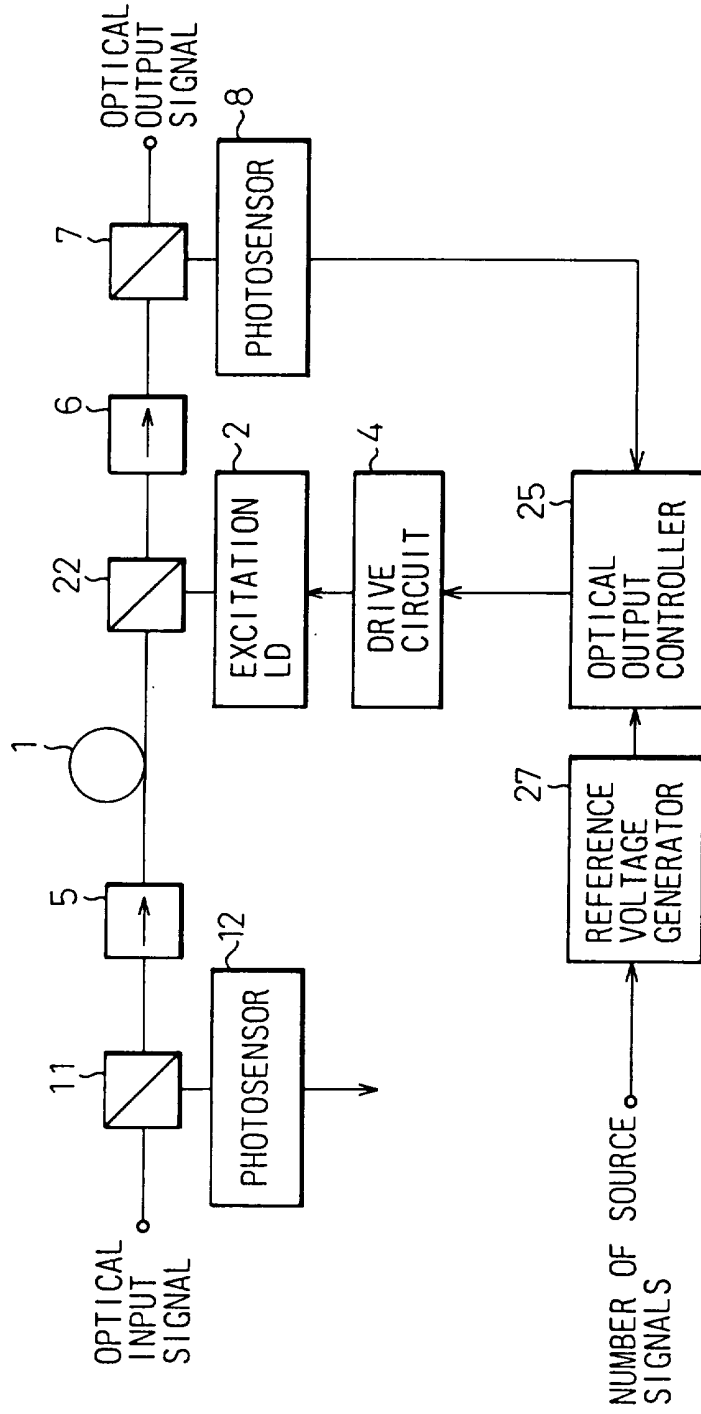

Fig.11



NUMBER OF SOURCE SIGNALS

Fig.12

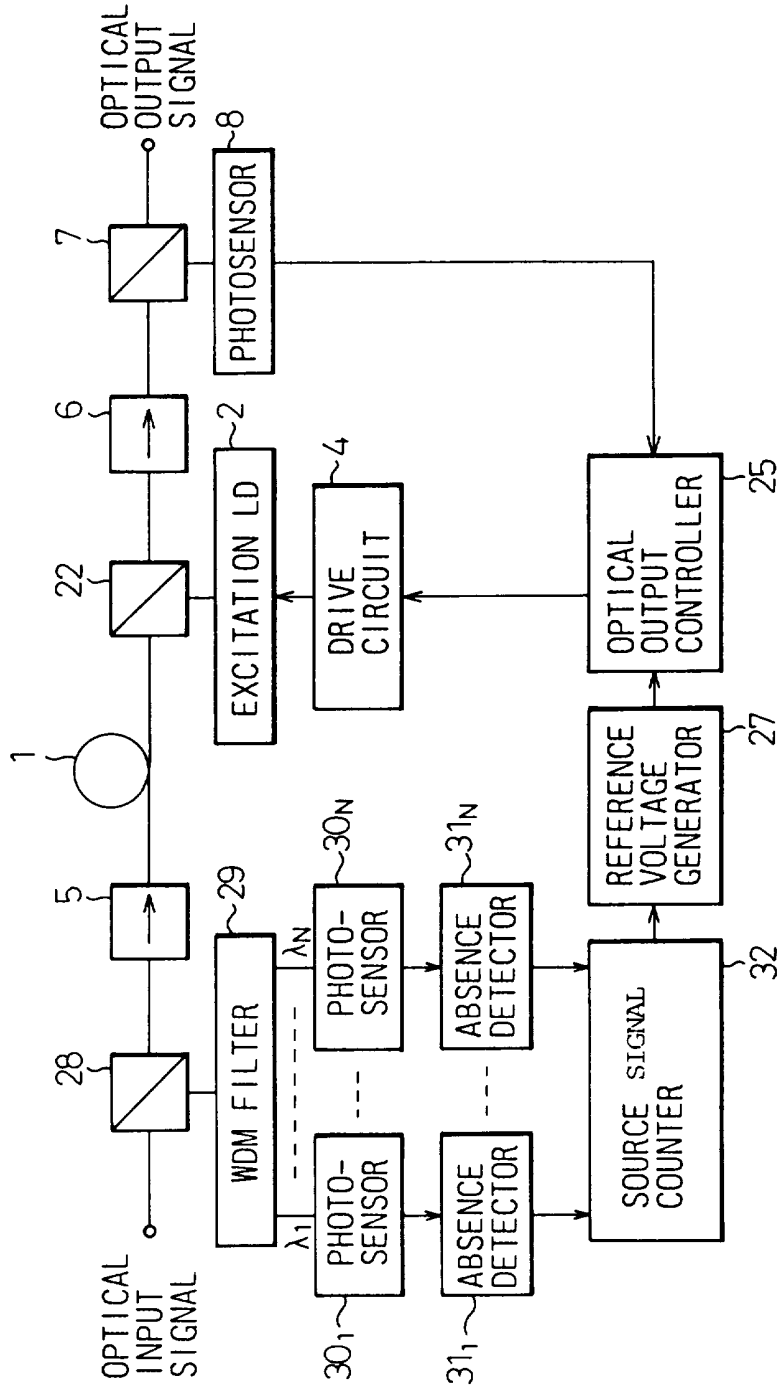

Fig.13

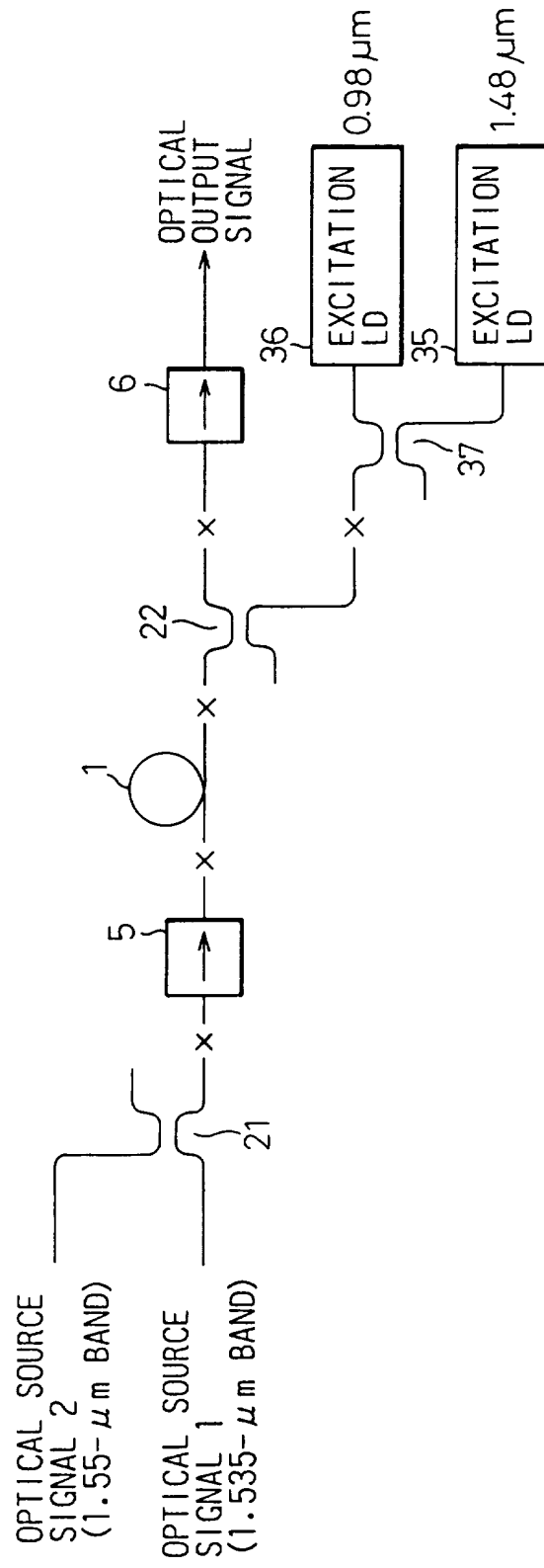

Fig.14

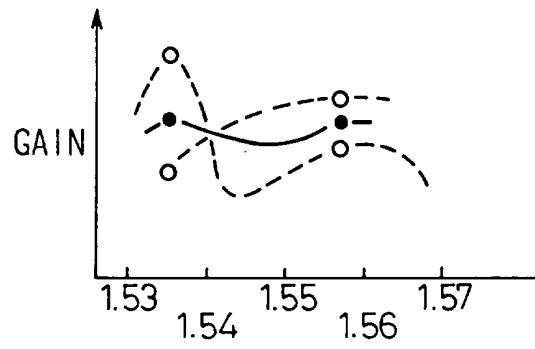

Fig.15

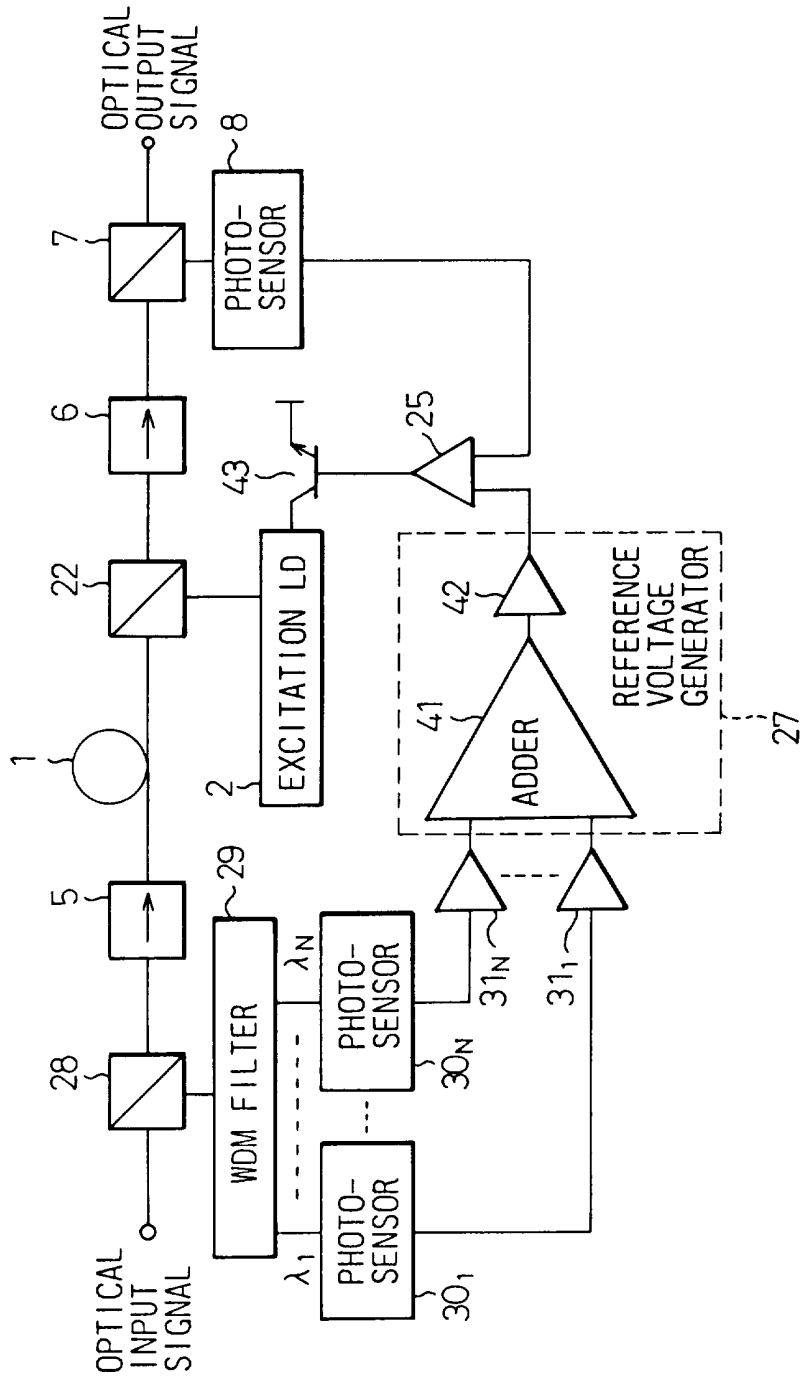
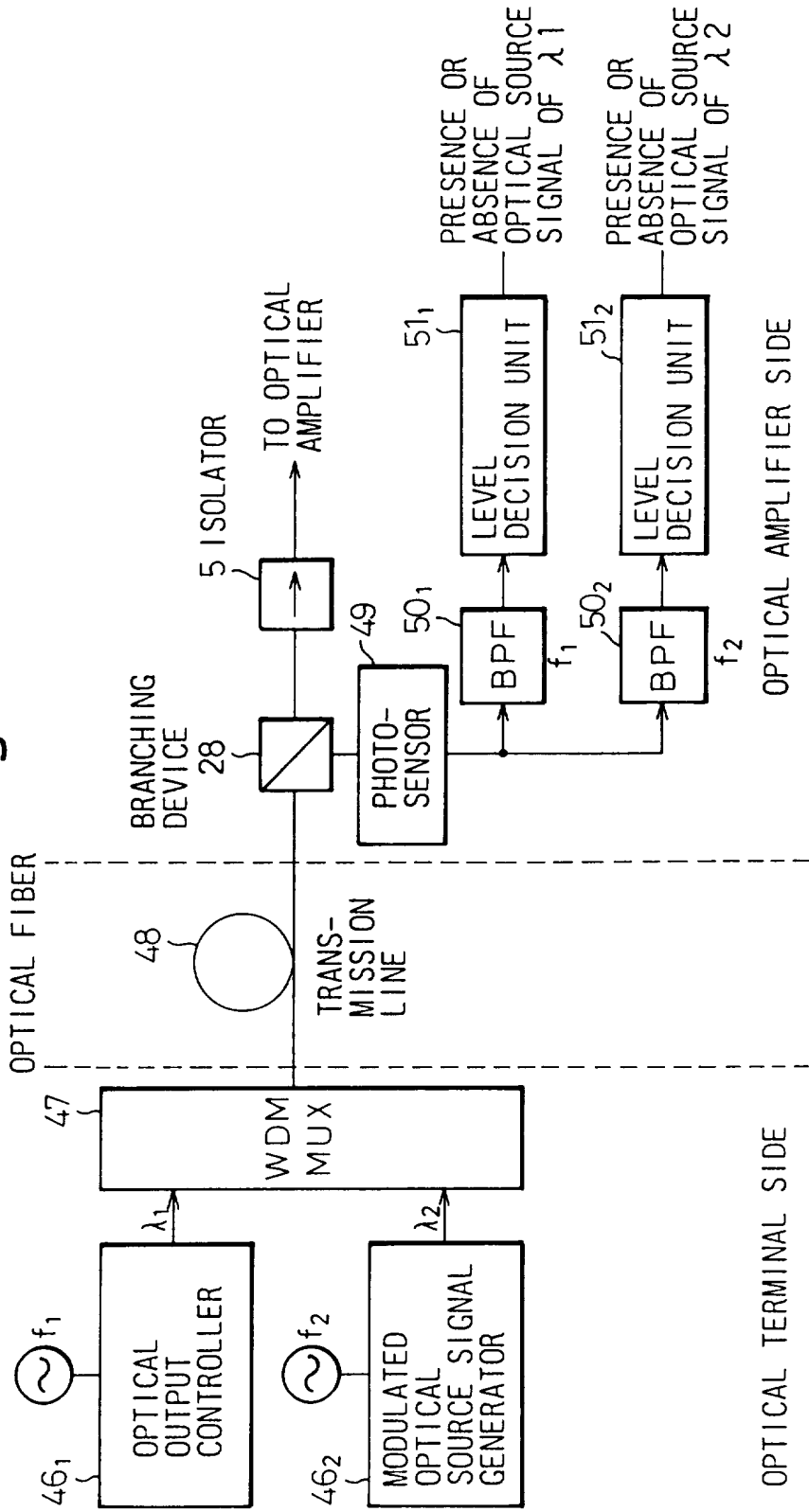

Fig.16



OPTICAL TERMINAL SIDE

OPTICAL AMPLIFIER SIDE

Fig.17

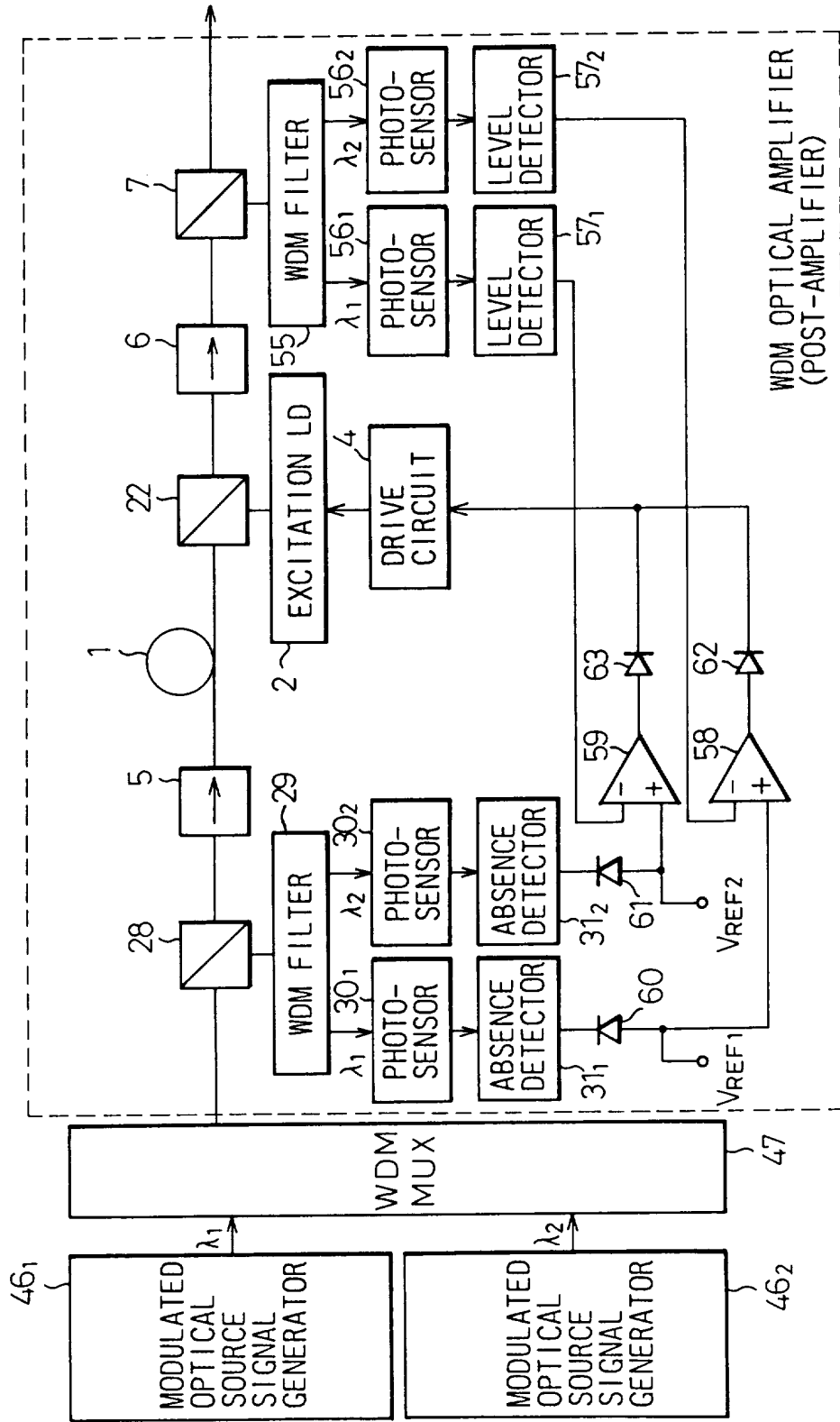

Fig.18

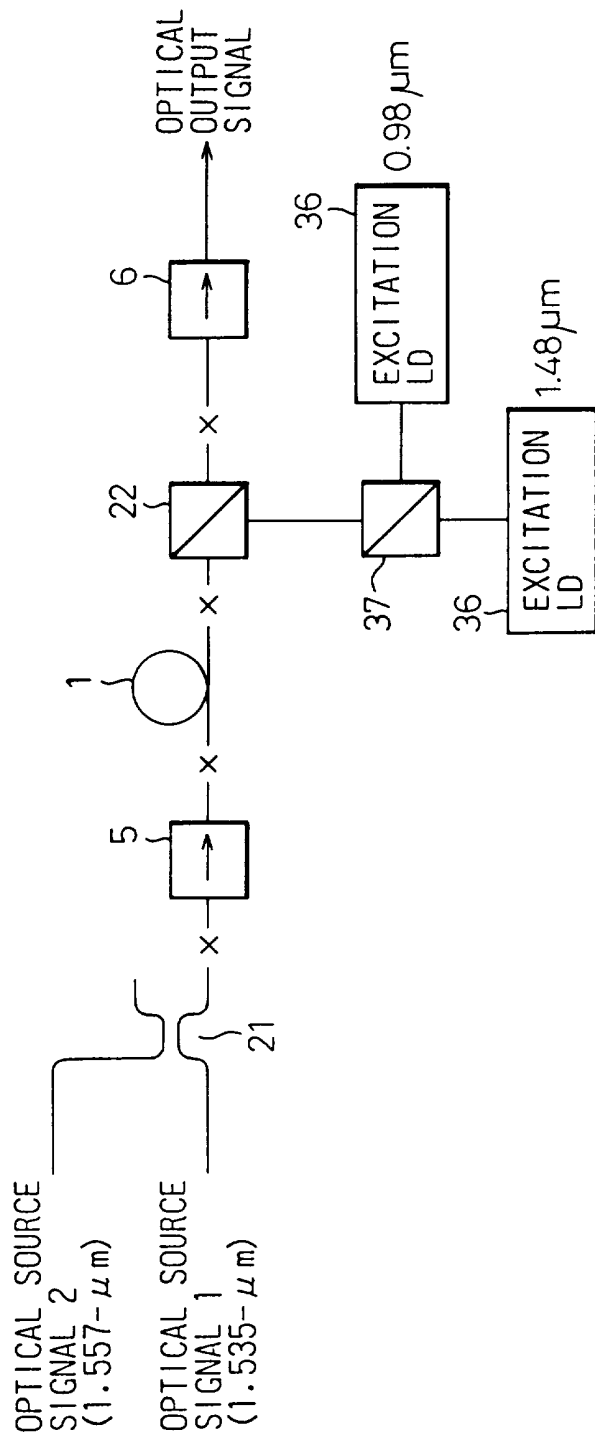

Fig. 19

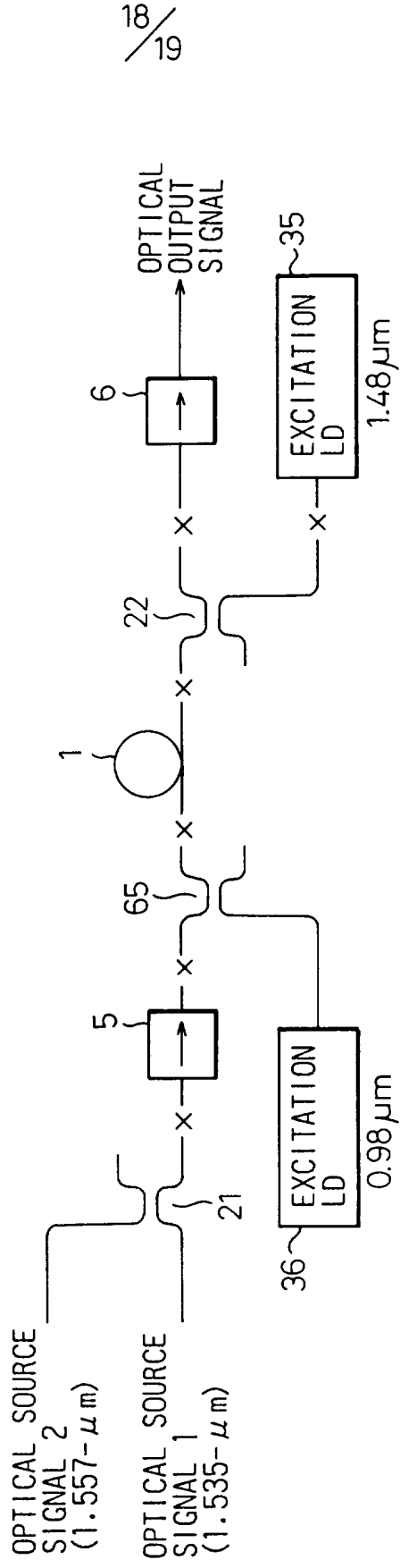
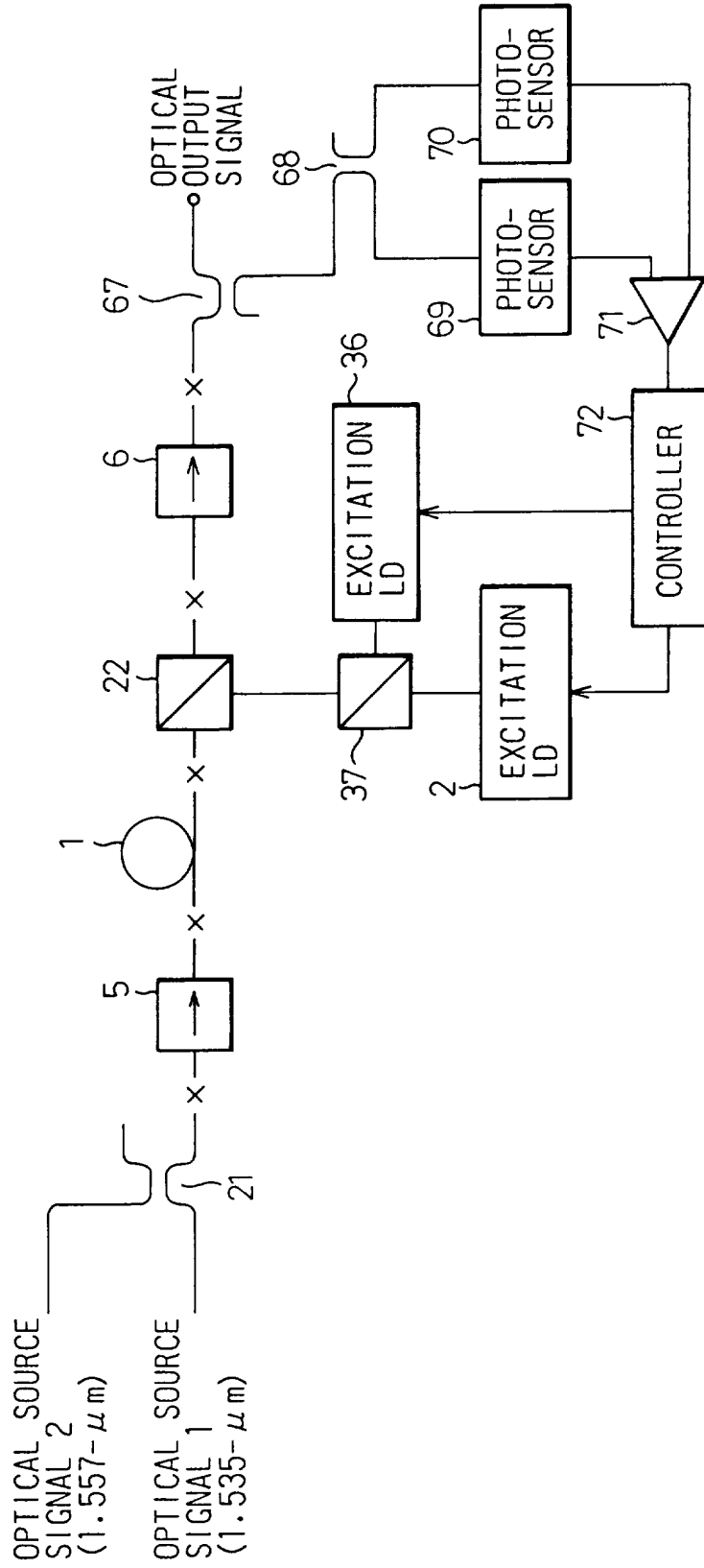

Fig. 20



OPTICAL AMPLIFICATION OF
WAVELENGTH-DIVISION-MULTIPLEXED SIGNALS

The present invention relates to optical
5 amplification of wavelength-division-multiplexed
signals for example to an output control system and
output control circuit for individually controlling the
levels of optical signals, having different
wavelengths, contained in a wavelength-division-
10 multiplexed optical output signal.

A wavelength-division-multiplexing optical
transmission system multiplexes optical signals having
different wavelengths into a wavelength-division-
multiplexed optical signal and transmits the same
15 through an optical fiber. This system is capable of
increasing the transmission capacity of each optical
fiber depending on the number of optical signals
multiplexed.

An optical amplifier employing an erbium (Er)doped
20 optical fibre is often used because it effectively
amplifies the 1.55- μm -band optical signals that are
generally used in optical communication. This kind of
optical amplifier is useful as a post-amplifier for a
transmitter, a preamplifier for a receiver, or an
25 in-line amplifier for a repeater, to extend the
transmission distance at low cost.

Wavelength division multiplexing (WDM) effectively
increases transmission capacity, and multiplexing
1.55- μm -band optical signals is preferred.

30

35

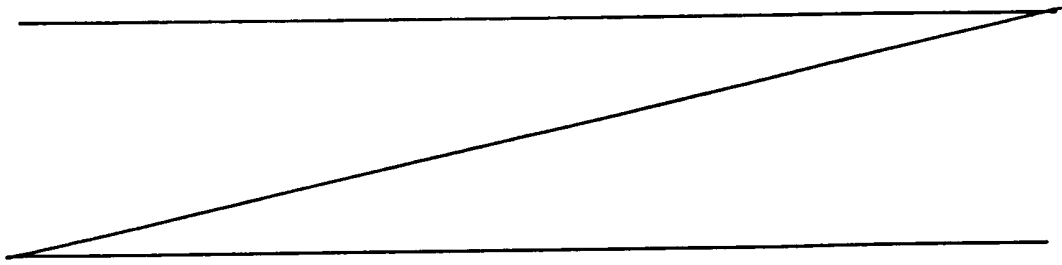

To multiplex and demultiplex optical signals of different wavelengths, optical devices must be employed. Employing optical devices, however, causes a loss of transmission distance. To compensate for the loss, optical amplifiers are needed. A combination of WDM and optical amplifiers forms a favorable means to transmit many optical signals over a large distance.

Optical amplifiers usually employ a constant output control technique. This technique is adopted not only for amplifying a single-wavelength optical signal but also for amplifying a wavelength-division-multiplexed optical signal composed of a plurality of optical signals having individual wavelengths, to provide a constant optical output level.

The wavelength-division-multiplexed optical signal usually consists of two optical signals having different wavelengths, one in a 1.535- μm band and the other in a 1.55- μm band. These bands are favorable because erbium-doped optical fibers of the optical amplifier provide high gains on signals in the range of 1.52 μm to 1.54 μm and in the range of 1.54 μm to 1.57 μm .

According to the constant output control technique, the total output level of the amplifier is constant, and therefore, the level of each of the optical signals is obtained by dividing the total output level by the number of the optical signals. Accordingly, the levels of the optical signals may be insufficient when they arrive at a receiver. If one of the optical signals is absent due to some reason, the level of the absent optical signal is distributed to the other optical signals, to increase the levels thereof. This may cause an error at a receiver. On the other hand, if an optical signal having its own wavelength is added, it will decrease the levels of the other optical signals. This is a first problem of a previously-considered WDM optical amplifier.

The gain of the WDM optical amplifier has wavelength dependency. The wavelength dependency sometimes causes a reception error, which is aggravated by fluctuations in a light source in an optical terminal, in a multiplexer-demultiplexer, or in transmission fibers. Namely, these fluctuations change the levels of the optical signals contained in a wavelength-division-multiplexed optical signal at a receiver. Then, the receiver cannot detect every optical signal. In particular, any optical signal at a low level easily causes a reception error. This is a second problem of the previously-considered WDM optical amplifiers.

A previously-considered WDM optical amplifier prepares a monitor signal and checks the level of the monitor signal to keep the optical output of the amplifier constant. Due to the second problem mentioned above, the gain of the amplifier for the optical output is not always equal to that for the monitor signal. This results in fluctuations in the optical output of the amplifier. Preparing the monitor signal involves additional costs. The monitor signal will not be a true representative of the optical output of the amplifier if the system for preparing the monitor signal fails.

A previously-considered WDM optical amplifier involves a gain tilt. When collectively amplifying two optical signals with one excitation beam, the optical amplifier causes a gain tilt to weaken one optical signal relative to the other depending on the wavelength of the excitation beam, although the amplifier uniformly amplifies a single optical signal.

It is desirable to provide a wavelength-division-multiplexing (WDM) optical amplifier capable of optimizing the output level of each optical signal having an individual wavelength. When there are just two such individual signals, of different respective

wavelength-bands, it is desirable to minimise the difference between the respective effective gains of the amplifier for the two different signals.

An embodiment of a first aspect of the present invention can provide an optical amplifier for
5 amplifying a wavelength-division-multiplexed optical input signal composed of optical signals having different wavelengths, the level of the optical output of the amplifier being controlled according to the
10 number of the optical signals.

To control the level of the optical output of the amplifier, the power of an excitation beam is controlled. The optical output of the amplifier is controlled so that each of the optical signals has a
15 given output level. Alternatively, the optical output of the amplifier is controlled according to an external reference input that is set according to the number of the optical signals. The external reference input corresponding to the number of the optical signals may
20 be set through a switch.

The number of the optical signals is detected, and the optical output of the amplifier is controlled accordingly. To detect the number of the optical signals, the input signal is branched, the branched
25 signal is demultiplexed through a filter into the optical signals, and the optical signals are checked to see if they are present. Alternatively, the optical signals are modulated with different frequencies and are multiplexed into the
30 wavelength-division-multiplexed optical input signal. The input signal is converted into an electric signal, which is separated into modulation frequency components. The modulation frequency components are checked to see if they are present, to thereby
35 determine the number of the optical signals. The modulation frequencies are selected to suppress induced

Brillouin scattering in an optical fiber that transmits the optical signal.

An embodiment of a second aspect of the present invention can provide an optical amplifier for
5 amplifying a wavelength-division-multiplexed optical input signal composed of optical

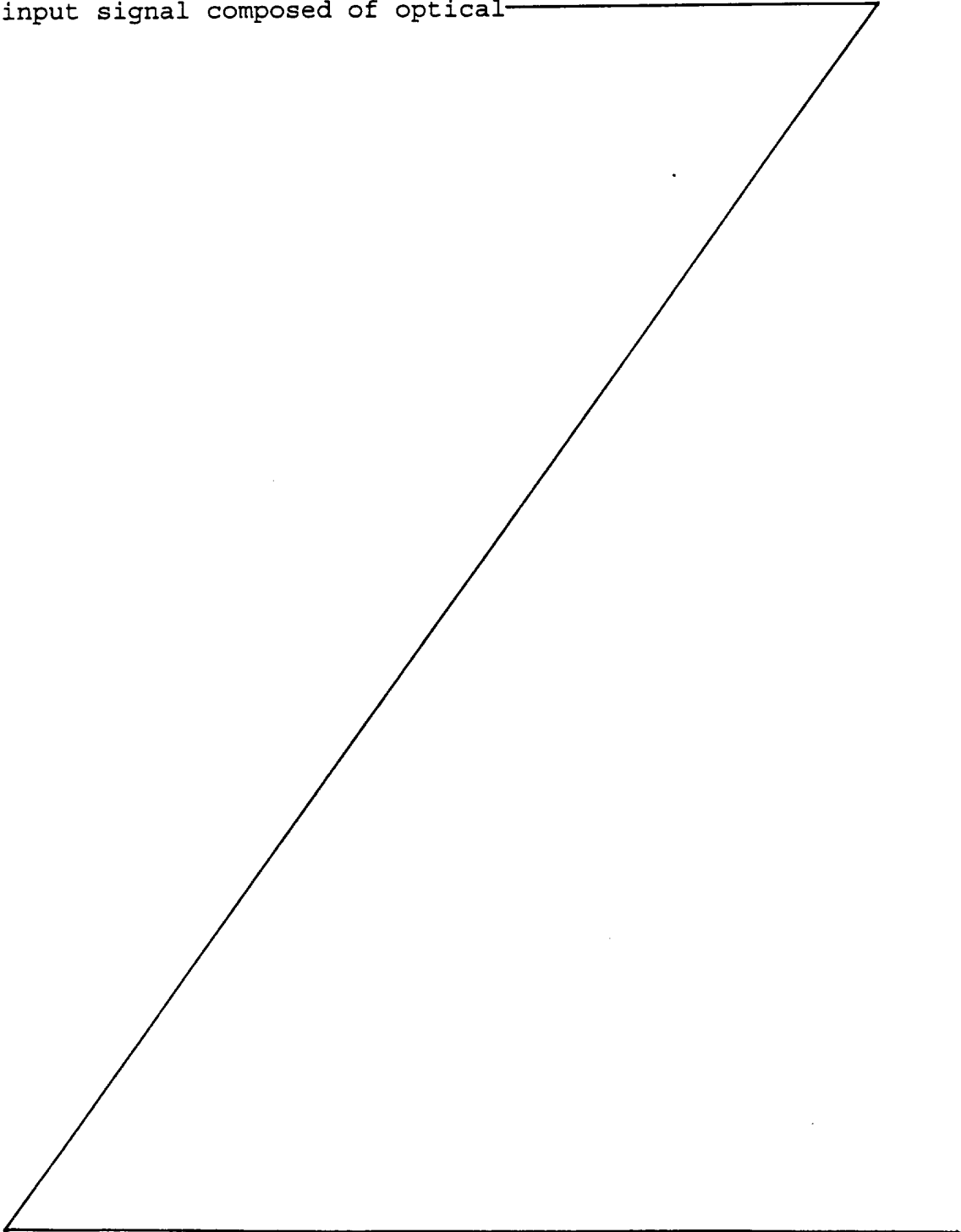

signals having different wavelengths, the level of each of the signals being detected to control the gain of the amplifier so that the weakest one of the optical signals may have a required output level and each of the optical signals may secure the required output level or more.

To detect the level of each of the optical signals, the input signal is demultiplexed through a filter into the optical signals, the optical signals are converted into electric signals, and the levels of the electric signals are measured to determine the levels of the optical signals. Alternatively, the optical signals may be modulated with different frequencies and are multiplexed into the wavelength-division-multiplexed optical input signal. The input signal is converted in the amplifier into an electric signal, which is separated into modulation frequency components. The levels of the modulation frequency components are measured to determine the level of each of the optical signals.

The amplifier is provided with a unit for detecting the presence of each of the optical signals so that any optical signal that is absent is excluded from the control of securing a required output level for each of the optical signals that are present.

An embodiment of a third aspect of the present invention can provide an optical amplifier for amplifying a wavelength-division-multiplexed optical input signal composed of an optical signal of 1.535- μm -band wavelength and an optical signal of 1.55- μm -band wavelength, by sending the input signal to an erbium-doped optical fiber and by simultaneously applying an excitation beam of 0.98- μm -band wavelength and an excitation beam of 1.48- μm -band wavelength to the optical fiber, when the gain of the amplifier on the optical signal of 1.535- μm -band wavelength is greater than that on the optical signal of 1.55- μm -band wavelength with respect to the excitation beam of 0.98- μm -band wavelength, and when the gain of the amplifier on the optical signal of 1.535- μm -band wavelength is smaller

than that on the optical signal of 1.55- μm -band wavelength with respect to the excitation beam of 1.48 μm -band wavelength.

5 The excitation beam of 0.98- μm -band wavelength and the excitation beam of 1.48- μm -band wavelength may be multiplexed and applied to the optical fiber to amplify the input signal. Alternatively, these excitation beams may be applied to different locations of the optical fiber, respectively, to amplify the input signal.

10 Reference will now be made, by way of example to the accompanying drawings, in which:

Fig. 1 is a block diagram showing a system for controlling an optical amplifier;

15 Fig. 2 is a block diagram showing a previously-considered WDM optical amplifier;

Fig. 3 is a block diagram showing a previously-considered WDM optical amplifier involving two optical signals having different wavelengths;

20 Fig. 4(a) is a graph showing the gain characteristic of the amplifier of Fig. 3 with respect to a 1.48- μm excitation beam;

Fig. 4(b) is a graph showing the gain characteristic of the amplifier of Fig. 3 with respect to a 0.98- μm excitation beam;

25 Fig. 5 is a block diagram showing a gain measuring system of a WDM optical amplifier;

Fig. 6(a) is a graph showing the gain characteristic of a WDM optical amplifier with a small $N_2/(N_2 - N_1)$;

30 Fig. 6(b) is a graph showing the gain characteristic of a WDM optical amplifier with a large $N_2/(N_2 - N_1)$;

Fig. 7 is a graph showing characteristic curves for explaining a gain tilt of a WDM optical amplifier;

35 Fig. 8(a) is a graph showing changes in the gain

- characteristic of a WDM optical amplifier with weak optical signals or a strong excitation beam;

Fig. 8(b) is a graph showing changes in the gain characteristic of a WDM optical amplifier with strong optical signals or a weak excitation beam;

Fig. 9 is a graph showing changes in dG/dA of a WDM optical amplifier with respect to excitation beams having different wavelengths;

Fig. 10 is a block diagram of a first embodiment of the present invention;

Fig. 11 is a block diagram of a second embodiment of the present invention;

Fig. 12 is a block diagram of a third embodiment of the present invention;

Fig. 13 is a block diagram of a fourth embodiment of the present invention;

Fig. 14 is a graph showing the gain characteristic of the amplifier of Fig. 13.

Fig. 15 is a block diagram showing a fifth embodiment of the present invention;

Fig. 16 is a block diagram showing a sixth embodiment of the present invention;

Fig. 17 is a block diagram showing a second embodiment of the present invention;

Fig. 18 is a block diagram showing an eighth embodiment of the present invention;

Fig. 19 is a block diagram showing a ninth embodiment of the present invention; and

Fig. 20 is a block diagram showing a tenth embodiment of the present invention.

Figure 1 shows a previously-considered system for controlling an optical amplifier employing the constant output control technique. The system includes an erbium-doped optical fiber 1, an excitation laser diode 2 for applying an excitation beam to the optical

fiber 1, a multiplexer-demultiplexer 3 for combining the excitation beam with an optical signal and providing an optical output signal, and a drive circuit 4 for driving the laser diode 2.

5 An optical input signal is sent to the optical fiber 1 through an isolator 5 that isolates the optical fiber 1 from the input. The optical fiber 1 amplifies the input signal according to the excitation beam and provides an amplified optical output signal, which is sent out
10 through an isolator 6.

A branching device 7 branches a part of the optical output signal. The branched part is converted by a photosensor 8 into an electric signal whose level is detected by a level detector 9. A comparator 10 compares
15 the detected level with a reference voltage V_{REF} , and according to the difference between them, controls the drive circuit 4. The drive circuit 4 drives the laser diode 2 accordingly. In this way, the strength of the excitation beam emitted from the laser diode 2 is
20 controlled to keep the optical output signal constant.

A branching device 11 is connected to the input end, to branch a part of the optical input signal. The branched part is converted by a photosensor 12 into an electric signal. An absence detector 13 checks the level
25 of the electric signal, and upon detecting an absence of the input signal, issues a shutdown signal to stop the drive circuit 4 and turn off the excitation beam of the laser diode 2. If the laser diode 2 is not turned off, the control system for keeping the optical output of the
30 amplifier constant increases its gain to only amplify noise. If an optical input signal resumes under this state, the system will excessively increase the optical output to badly affect a receiver.

35 Figure 2 shows a previously-considered wavelength-division-multiplexing (WDM) optical amplifier. The amplifier has an optical fiber 14, a semiconductor laser amplifier 15, a branching device 16 for branching a part

of an optical output signal of the laser amplifier 15, a drive circuit 17 for driving the laser amplifier 15, a demultiplexer 18 for demultiplexing the branched output signal into an optical signal, a photosensor 19 for
5 converting the optical signal into an electric signal, and a gain controller 20 for controlling the gain of the laser amplifier 15.

The input signal to the amplifier is a wavelength-division-multiplexed optical signal composed of optical
10 signals λ_1 and λ_2 , as well as an optical monitor signal λ_m . The branching device 16 separates, some of the optical output signal, and the demultiplexer 18 separates the monitor signal λ_m from the branched output signal. The monitor signal λ_m is converted by the photosensor 19
15 into an electric signal. The gain controller 20 compares the level of the electric signal with a reference voltage (not shown), and according to the difference between them, controls the drive circuit 17 to keep the gain of the laser amplifier 15 constant.

20 Like the amplifier _____ of Fig. 1 for amplifying a single-wavelength optical signal, the WDM amplifier _____ of Fig. 2 employs a constant output control technique to always provide an optical output signal of constant strength.

25 The wavelength-division-multiplexed optical signal amplified by this amplifier is composed of, for example, two optical signals having different wavelengths, e.g., a 1.535- μm -band wavelength and a 1.55- μm -band wavelength. The reason why these wavelengths are selected is because
30 an erbium-doped optical fiber of the amplifier shows high gains on signals whose wavelength ranges from 1.52 μm to 1.54 μm and on signals whose wavelength ranges from 1.54 μm to 1.57 μm .

35 Figure 3 shows a previously-considered WDM optical amplifier for handling two optical signals having different wavelengths.

_____ The same reference marks as those of Fig. 1 represent like parts. The amplifier of

Fig. 3 has a multiplexer 21 for multiplexing an optical signal 1 of 1.535- μm -band wavelength and an optical signal 2 of 1.55- μm -band wavelength, and a WDM coupler 22 for multiplexing and demultiplexing a wavelength-division-multiplexed optical signal and an excitation beam.

The multiplexer 21 multiplexes the optical signals 1 and 2. The multiplexed signal is sent to an erbium-doped optical fiber 1 through an isolator 5. An excitation beam from an excitation laser diode 2 is sent to the optical fiber 1 through the WDM coupler 22 to amplify the optical signals 1 and 2. The amplified signal is sent outside through an isolator 6.

Figures 4(a) and 4(b) show the gain characteristic of the optical amplifier of Fig. 3, in which Fig. 4(a) shows the gain characteristic with an excitation beam of 1.48- μm -band wavelength (hereinafter referred to as the 1.48- μm excitation), and Fig. 4(b) shows the gain characteristic with an excitation beam of 0.98- μm -band wavelength (hereinafter referred to as the 0.98- μm excitation). In Fig. 4(a), the 1.48- μm excitation achieves a large gain on the optical signal 2 of 1.55- μm -band wavelength. In this case, the optical signal 1 of 1.535- μm -band wavelength is hardly transmitted. In Fig. 4(b), the 0.98- μm excitation achieves a large gain on the optical signal 1 of 1.535- μm -band wavelength, and the optical signal 2 of 1.55- μm -band wavelength is hardly transmitted.

Figure 5 shows a gain measuring system for a WDM optical amplifier. The same reference marks as those of Fig. 3 represent like parts. This system has a spectrum analyzer 23 for measuring the spectral distribution of an optical output signal.

A multiplexer 21 multiplexes an optical signal 1 ($\lambda = 1.56 \mu\text{m}$) and an optical signal 2 ($\lambda = 1.53 \mu\text{m}$ to 1.57 μm). The multiplexed signal is sent to an erbium-doped optical fiber 1 through an isolator 5. An excitation

laser diode 2 emits an excitation beam ($\lambda = 1.48$ or 0.98 μm), which is applied to the optical fiber 1 through a WDM coupler 22 to amplify the multiplexed signal. The amplified signal is sent to the spectrum analyzer 23 through an isolator 6, and the spectrum analyzer 23 measures the output levels of the optical signals according to their spectra.

When the amplifier _____ of Fig. 1 is employed to amplify a wavelength-division-multiplexed optical signal, it provides an optical output signal of constant level. Namely, the level of each optical signal contained in the output signal is obtained by dividing the total output level by the number of the optical signals. Accordingly, the optical signals may have insufficient levels when they arrive at a receiver. If one of the optical signals is absent due to some reason, the level of the absent optical signal is distributed to the other optical signals, to increase the levels thereof. This may cause an error at a receiver. On the other hand, if an optical signal having its own wavelength is added, it will decrease the levels of the other optical signals. This is the problem of a previously-considered WDM optical amplifier.

The gain of the WDM optical amplifier is wavelength dependent. The wavelength dependency sometimes causes a reception error, which is aggravated by fluctuations in a light source of an optical terminal, multiplexer-demultiplexers, and transmission fibers. Namely, these fluctuations change the levels of optical signals contained in a wavelength-division-multiplexed optical signal from one another at a receiver. Then, the receiver cannot detect the optical signals individually. In particular, any optical signal of low level easily causes a reception error. This is another problem of a previously-considered WDM optical amplifier.

The amplifier _____ of Fig. 2 prepares a monitor signal and checks the level of the monitor signal

to keep the optical output of the amplifier constant. Due to the problem mentioned above, the gain of the amplifier on the optical output is not always equal to that on the monitor signal. This results in the optical output of the amplifier fluctuating. Preparing the monitor signal involves additional costs. The monitor signal will not be a true representative of the optical output of the amplifier if the system for preparing the monitor signal fails.

Figures 6(a) and 6(b) explain the gain characteristic of a WDM optical amplifier, in which Fig. 6(a) is with a small $N_2/(N_2 - N_1)$ and Fig. 6(b) is with a large $N_2/(N_2 - N_1)$. Here, N_1 is the number of photons in a ground state, and N_2 is the number of photons in an excited state. An ordinate represents emitted energy $N_2\sigma_e$ (σ_e being a cross-sectional emission area) and absorbed energy $N_1\sigma_a$ (σ_a being a cross-sectional absorption area), and an abscissa represents the wavelength (μm) of an optical signal.

The difference between the emitted energy $N_2\sigma_e$ and the absorbed energy $N_1\sigma_a$ corresponds to the gain of the amplifier. When $N_2/(N_2 - N_1)$ is small, i.e., when the distribution of the ground state is sufficiently small and the distribution of the excited state is sufficiently large, the gain g_l ($\lambda = 1.535 \mu\text{m}$) of the amplifier around a wavelength of $1.535 \mu\text{m}$ is larger than the gain g_h ($\lambda = 1.55 \mu\text{m}$) of the amplifier around a wavelength of $1.55 \mu\text{m}$. On the other hand, when $N_2/(N_2 - N_1)$ is large, i.e., when the distribution of the excited state is not sufficiently large, g_l ($\lambda = 1.535 \mu\text{m}$) is smaller than g_h ($\lambda = 1.55 \mu\text{m}$).

When an excitation beam of $1.48\text{-}\mu\text{m}$ -band wavelength is employed, the cross-sectional emission area extends nearly to $1.45 \mu\text{m}$, and therefore, it is difficult to zero the distribution of the ground state. When the amplifier serves as a post-amplifier for a multiplexed signal containing two optical signals, $N_2/(N_2 - N_1)$ becomes

larger so that g_1 ($\lambda = 1.535 \mu\text{m}$) becomes smaller than g_h ($\lambda = 1.55 \mu\text{m}$) to cause a gain tilt.

Figure 7 shows an example of a gain tilt when optical signals 1 and 2 are collectively amplified with an excitation beam of $1.48 \mu\text{m}$ in wavelength. An ordinate represents the output level of the optical signal 2, and an abscissa represents the wavelength of the optical signal 2. A curve "A" is obtained when only the wavelength of the optical signal 2 is changed without the optical signal 1. A curve "B" is obtained when the wavelength of the optical signal 2 is changed from $1.53 \mu\text{m}$ to $1.57 \mu\text{m}$ with the wavelength of the optical signal 1 being fixed at $1.56 \mu\text{m}$.

As shown in the figure, the amplifier shows a flat amplification characteristic with respect to a single optical signal, while it causes a gain tilt with respect to two optical signals that are collectively amplified. In the latter case, the output level of the optical signal 2 drops in a short-wavelength region.

When an excitation beam of $0.98 \mu\text{m}$ in wavelength is employed, it will sufficiently reduce the distribution of the ground state, to provide the gain characteristics of Figs. 6(a) and 6(b). This is because no emission occurs around the excitation wavelength of $0.98 \mu\text{m}$, unlike the excitation beam of $1.48 \mu\text{m}$.

Figures 8(a) and 8(b) show changes in the gain characteristic of a WDM optical amplifier with respect to an excitation beam of $0.98 \mu\text{m}$ in wavelength, in which Fig. 8(a) is with a weak optical signal or a strong excitation beam, and Fig. 8(b) is with a strong optical signal or a weak excitation beam.

In Fig. 8(a), the gain of the amplifier for an optical signal of $1.535 \mu\text{m}$ in wavelength is larger than that for an optical signal of $1.557 \mu\text{m}$ in wavelength when the optical signals are weak or the excitation beam is strong. In Fig. 8(b), the gain of the amplifier on the optical signal of $1.535 \mu\text{m}$ in wavelength is smaller than

that on the optical signal of 1.557 μm in wavelength when the optical signals are strong or the excitation beam is weak.

5 Figure 9 shows changes in $dG/d\lambda$ of a WDM optical amplifier due to changes in the wavelength of an excitation beam. The 1.48- μm excitation involves a transition probability to a ground state, so that transition from Fig. 8(a) to Fig. 8(b) is speedier under the 1.48- μm excitation than under the 0.98- μm excitation
10 when the strength of an optical signal is increased.

In Fig. 9, the 0.98- μm excitation keeps the shape of Fig. 8(a) in the range surrounded with dotted lines. On the other hand, the 1.48- μm excitation takes the shape of Fig. 8(b) that causes a gain tilt.

15

A WDM optical amplifier embodying is desirably capable of optimizing the output level of each of optical signals having different wavelengths or minimizing a difference in the gain of the amplifier with respect to two optical signals having different
20 wavelengths.

20

Figure 10 shows a first optical amplifier embodying
25 _____ the present invention. The same reference marks as those of the preceding drawings represent like parts. This amplifier includes an optical output controller 25.

25

An optical input signal is sent to an erbium-doped optical fiber 1 through an isolator 5. The optical fiber 1 amplifies the input signal according to an excitation beam applied through a WDM coupler 22. The amplified signal is sent outside through an isolator 6.

30

A branching device 7 is arranged at an output end, to branch a part of the optical output signal. The
35 branched part is converted by a photosensor 8 into an electric signal, which is sent to the optical output

35

controller 25. The optical output controller 25 compares the electric signal with a variable reference voltage, and according to the difference between them, controls a drive circuit 4, which provides an excitation laser diode 2 with a drive current. The strength of an excitation beam emitted from the laser diode 2 is controlled accordingly, to control the level of the optical output signal.

A branching device 11 arranged at an input end separates a part of the optical input signal. The separated part is converted by a photosensor 12 into an electric signal. The level of the electric signal is checked by an absence detector (not shown). When the input signal is absent, the absence detector issues a shutdown signal to stop the drive circuit 4 and turn off the excitation beam from the laser diode 2.

The variable reference voltage that determines the output level of the amplifier is varied according to the number of optical signals contained in an optical input signal.

Namely, the output level of the amplifier is controlled such that the output level of each optical signal is always constant. When the output level of each of "N" optical signals must be P_{out} , the total output level of the amplifier is controlled to $P_{out} \times N$.

Figure 11 shows a second optical amplifier embodying the present invention. The same reference marks as those of Fig. 10 represent like parts. This amplifier has a reference voltage generator 27 for generating a reference voltage corresponding to the number of optical signals contained in a wavelength-division-multiplexed optical input signal.

The reference voltage is sent to an optical output controller 25. The optical output controller 25 compares the reference voltage with an electric signal that is provided by a photosensor 8 and corresponds to the level of an optical output signal. According to the difference

between the compared signals, the optical output controller 25 controls a drive circuit 4, which provides an excitation laser diode 2 with a drive current. In response to the drive current, the strength of an excitation beam emitted from the laser diode 2 is controlled. Consequently, the level of the optical output signal is controlled according to the number of the optical signals.

Figure 12 shows a third optical amplifier embodying _____ the present invention. The same reference marks as those of Fig. 11 represent like parts.

A branching device 28 divides a wavelength-division-multiplexed optical input signal. A WDM filter 29 demultiplexes the input signal into optical signals having wavelengths of λ_1 to λ_N . Photosensors 301 to 30N convert the optical signals into electric signals, respectively. According to the electric signals, absence detectors 311 to 31N detect the presence or absence of the optical signals, respectively. According to the presence and absence information, an optical signal counter 32 provides the number of the optical signals.

According to the number of the optical signals, a reference voltage generator 27 generates a reference voltage, which is sent to an optical output controller 25. The optical output controller 25 controls the strength of an excitation beam emitted from an excitation laser diode 2 accordingly. As a result, the level of an optical output signal of the amplifier is controlled according to the number of the optical signals contained in the input signal.

Figure 13 shows a fourth optical amplifier embodying _____ the present invention. The same reference marks as those of Fig. 3 represent like parts. This amplifier has an excitation laser diode 35 for emitting an excitation beam of 1.48- μ m-band wavelength, an excitation laser diode 36 for emitting an excitation beam of 0.98- μ m-band wavelength, and a multiplexer 37.

Figure 14 shows the gain characteristic of the amplifier of Fig. 13.

5 The multiplexer 37 multiplexes the excitation beam of 1.48- μm -band wavelength and the excitation beam of 0.98- μm -band wavelength, and applies the multiplexed beam to an erbium-doped optical fiber 1. This amplifier shows an intermediate gain characteristic between the gain characteristics of Figs. 4(a) and 4(b). Accordingly, this amplifier is capable of minimizing the difference
10 between the gains thereof on an optical signal 1 having a wavelength of 1.535 μm and an optical signal 2 having a wavelength of 1.55 μm .

The functions and operations of embodiments of the present invention are preferably as follows:

15 (1) The _____ total level of the optical output of the amplifier is controlled according to the number of optical signals of different wavelengths _____ contained in a wavelength-division-multiplexed optical input signal, so that _____
20 _____ a receiver always receives each of the optical signals at a required level. Even if one of the optical signals is absent, no reception error will occur because the level of each of the remaining optical signals is kept at the required level irrespective of the
25 absence.

(2) The output control of _____ item (1) may be carried out by controlling the power of an excitation beam applied to the input signal.

30 (3) The output control of _____ item (1) may be carried out by keeping the level of each of the optical signals constant.

(4) The output control of _____ item (1) may be carried out according to an external reference input corresponding to the number of the optical signals.

35 (5) The external reference input of _____ item (4) may be changed through a switch.

(6) The output control of _____ item (1) may be

carried out according to the number of the optical signals, which is detected by the amplifier itself.

5 (7) The detection of the number of the optical signals of — item (6) may be carried out by dividing the input signal, demultiplexing the signal into the optical signals through a filter, and determining the presence of each of the optical signals.

10 (8) The detection of the number of the optical signals of — item (6) may be carried out by modulating the optical signals with different frequencies, converting the input signal into an electric signal, separating the frequency-modulated components from one another according to the electric signal, and determining the presence of each of the frequency-modulated
15 components.

(9) The frequencies of the item (8) used for modulating the optical signals are selected to suppress induced Brillouin scattering in an optical fiber for transmitting the optical signal.

20 (10) The _____ level of each of the optical signals contained in the input signal is distorted and the gain of the amplifier is controlled so that the weakest one of the optical signals may have a required output level, and therefore, each of the optical signals
25 may have the required output level or above.

Even if the gain of the amplifier has wavelength dependency, each of the optical signals will have a required reception level to cause no reception error.

30 (11) The detection of the level of each of the optical signals of — item (10) may be carried out by separating the optical signals from one another through a filter, converting the separated signals into electric signals, and detecting the levels of the electric
35 signals.

(12) The detection of the level of each of the optical signals of — item (10) may be carried out by

modulating the optical signals with different frequencies, converting the input signal into an electric signal, separating the frequency-modulated components from one another according to the electric signal, and measuring the level of each of the separated components, to determine the level of each of the optical signals.

(13) The detection of the level of each of the optical signals of — item (10) may be carried out with the use of a unit for determining the presence of each of the optical signals. Absent ones of the optical signals are excluded, and the gain of the amplifier is controlled so that the weakest one of the optical signals may have a required output level, and therefore, each of the optical signals that are present may have the required output level or more.

(14) _____
_____ .An optical signal of 1.535- μ m-band wavelength and an optical signal of 1.55- μ m-band wavelength are transmitted to an erbium-doped optical fiber. When an excitation beam of 0.98- μ m-band wavelength is applied to the optical fiber, the gain of the amplifier for the optical signal of 1.535- μ m-band wavelength is larger than that for the optical signal of 1.55- μ m-band wavelength. When an excitation beam of 1.48- μ m-band wavelength is applied to the optical fiber, the gain of the amplifier on the optical signal of 1.535- μ m-band wavelength is smaller than that for the optical signal of 1.55- μ m-band wavelength.

In this case, an embodiment of the present invention simultaneously applies the excitation beams of 0.98- μ m-band wavelength and 1.48- μ m-band wavelength to the optical fiber, to thereby equalize the gain of the amplifier on the optical signal of 1.535- μ m-band wavelength with that on the optical signal of 1.55- μ m-band wavelength.

(15) In — item (14), the excitation beams of 0.98- μ m-band wavelength and 1.48- μ m-band wavelength may

be multiplexed and applied to the optical fiber.

(16) In — item (14), the excitation beams of 0.98- μm -band wavelength and 1.48- μm -band wavelength may be applied to different locations of the optical fiber, respectively.

Figure 15 shows a WDM optical amplifier according to a fifth — embodiment of the present invention. The same reference marks as those of Fig. 12 represent like parts. This amplifier has a reference voltage generator 27. The reference voltage generator 27 has an adder 41, for adding voltage signals corresponding to the number of optical signals of different wavelengths contained in a wavelength-division-multiplexed optical input signal to each other, and a level converter 42 for converting the voltage signal corresponding to the number of the optical signals into a reference voltage. A transistor 43 drives an excitation laser diode 2.

A branching device 28 divides the input signal. The input signal is separated by a WDM filter 29 into the optical signals having wavelengths of λ_1 to λ_N , which are converted by photosensors 301 to 30N into electric signals indicating the levels of the optical signals. Absence detectors 311 to 31N normalize each of the levels of the optical signals to 1V to indicate presence or 0V to indicate absence. The adder 41 adds the outputs of the absence detectors 311 to 31N to each other, to produce a voltage corresponding to the number of the optical signals.

The level converter 42 converts the voltage corresponding to the number of the optical signals into a reference voltage. A photosensor 8 provides a voltage representing the level of an optical output signal. An optical controller 25 compares the voltage provided by the photosensor 8 with the reference voltage from the level converter 42, and according to the difference between them, controls the transistor 43. The transistor 43 provides the laser diode 2 with a drive current. The

laser diode 2 emits an excitation beam whose strength is controlled so that the level of the optical output signal may correspond to the number of the optical signals.

5 Figure 16 shows an optical amplifier according to a sixth embodiment of the present invention. This embodiment determines whether or not each of optical signals contained in a wavelength-division-multiplexed optical signal is present. An optical terminal has a modulator 461 for modulating an optical signal of
10 wavelength λ_1 with a frequency f_1 , and a modulator 462 for modulating an optical signal of wavelength λ_2 with a frequency f_2 . A WDM multiplexer 47 multiplexes the modulated optical signals into a wavelength-division-multiplexed optical signal. An optical fiber 48
15 transmits the optical signal and inputs the same into the optical amplifier. A branching device 28 of the optical amplifier separates the input signal. A photosensor 49 converts the signal into an electric signal. A band-pass filter 501 extracts the signal of frequency f_1 from the electric signal. A band-pass filter 502 extracts the
20 signal of frequency f_2 from the electric signal. A level decision unit 511 determines the level of the signal of frequency f_1 and provides information indicating the presence or absence of the optical signal of wavelength
25 λ_1 . A level decision unit 512 determines the level of the signal of frequency f_2 and provides information indicating the presence or absence of the optical signal of wavelength λ_2 .

The optical terminal modulates each optical signal
30 with a frequency (phase) to identify the wavelength of the optical signal. Namely, the optical terminal modulates an optical signal having a wavelength of λ_1 with a frequency of f_1 , and an optical signal having a wavelength of λ_2 with a frequency of f_2 . These modulated
35 signals are multiplexed by the WDM multiplexer 47 into a wavelength-division-multiplexed optical signal.

The amplifier converts a branched part of the

optical input signal into an electric signal, which is passed through the band-pass filters to extract the optical signals modulated with the frequencies f_1 and f_2 , respectively. The levels of these signals are checked to provide information about the presence or absence of the optical signals. Generally, the second embodiment employing the electric filters to detect optical signals is less expensive than the first embodiment that employs the WDM filter to separate optical signals.

An optical fiber causes induced Brillouin scattering when the spectral purity of an optical signal transmitted through the optical fiber is high and when the level of the signal is higher than a threshold. The induced Brillouin scattering hinders the transmission of the optical signal. The induced Brillouin scattering is suppressible by modulating the transmission signal with a phase or frequency that expands the spectral band width. This technique increases the level of the transmission signal. Accordingly, the second embodiment is effective to prevent induced Brillouin scattering.

The modulation frequencies must be sufficiently high to suppress induced Brillouin scattering. If the frequencies are too high, however, the effect of suppressing the induced Brillouin scattering deteriorates. This is because, when a modulator modulates the amplitude of a current to drive a laser diode, to modulate the frequency of a beam emitted from the laser diode, the extremely high frequency deteriorates the efficiency between the amplitude modulation and the frequency modulation. This results in narrowing a frequency modulation width, thereby deteriorating the effect of suppressing the induced Brillouin scattering. Accordingly, modulation frequencies employed by the second embodiment must properly be selected to suppress the induced Brillouin scattering.

Figure 17 shows a WDM optical amplifier according to

a seventh embodiment of the present invention. This amplifier is employed as a post-amplifier. The same reference marks as those of Figs. 12 and 16 represent like parts. For the sake of simplicity, a wavelength-
5 division-multiplexed optical signal handled by this amplifier consists of two optical signals having individual wavelengths.

A branching device 7 separates a part of an optical output signal. A WDM filters 55 demultiplexes the signal
10 into optical signals having wavelengths λ_1 and λ_2 . Photosensors 561 and 562 convert the optical signals into electric signals, respectively. Level detectors 571 and 572 detect the levels of the electric signals, respectively.

A branching device 28 separates an optical input
15 signal. The signal is separated by a WDM filter 29 into optical signals having wavelengths λ_1 and λ_2 , respectively. The optical signals are converted by photosensors 301 and 302 into electric signals,
20 respectively. According to the levels of the electric signals, absence detectors 311 and 312 determine the presence or absence of the optical signals.

Comparators 58 and 59 compare the levels provided by the level detectors 571 and 572 with reference levels
25 VREF1 and VREF2, respectively. The comparators 58 and 59 provide outputs to logic diodes 62 and 63 to control a drive circuit 4. The drive circuit 4 drives an excitation laser diode 2. Accordingly, the strength of an excitation beam emitted from the laser diode 2 is
30 subjected to feedback control according the weakest one of the optical signals. As a result, the difference between the levels of the optical signals is minimized.

If any one of the absence detectors 311 and 312
35 detects the absence of the corresponding optical signal and provides an output of 0 V, the output level of the corresponding comparator drops due to a corresponding one of logic diodes 60 and 61. Then, according to feedback

control corresponding to the optical signal that is present, the drive circuit 4 drives the laser diode 2. Accordingly, an erbium-doped optical fiber 1 is never over excited.

5 As mentioned above, the embodiment of Fig. 17

can _____ compensate for a drop in the level of a signal due to the wavelength dependency of the gain of the amplifier.

10 Figure 18 shows an optical amplifier according to an eighth embodiment of the present invention. The same reference marks as those of Fig. 13 represent like parts.

An optical signal 1 having a wavelength of 1.535 μm and an optical signal 2 having a wavelength of 1.557 μm form a wavelength-division-multiplexed optical input
15 signal. The input signal is passed through an isolator 5 and is sent to an erbium-doped optical fiber 1. An excitation laser diode 35 emits an excitation beam having a wavelength of 1.48 μm , and an excitation laser diode 36
20 emits an excitation beam having a wavelength of 0.98 μm . A multiplexer 37 multiplexes these excitation beams. The multiplexed excitation beam is made incident to the optical fiber 1 through a WDM coupler 22.

The optical fiber 1 amplifies the input signal
25 accordingly. The amplified signal is transmitted through an isolator 6.

Since the optical fiber 1 is excited by the excitation beams of wavelengths of 1.48 μm and 0.98 μm , the amplifier provides a flat gain characteristic as
30 shown in Fig. 14 when amplifying an input signal composed of optical signals of wavelengths of 1.535 μm and 1.557 μm .

Figure 19 shows an optical amplifier according to a ninth embodiment of the present invention. The same
35 reference marks as those of Fig. 18 represent like parts. This embodiment has a WDM coupler 65.

An excitation laser diode 35 emits an excitation

beam having a wavelength of 1.48 μm , which is made incident to an erbium-doped optical fiber 1 through a WDM coupler 22. An excitation laser diode 36 emits an excitation beam having a wavelength of 0.98 μm , which is made incident to the optical fiber 1 through the WDM coupler 65.

Consequently, an optical input signal to the optical fiber 1 is excited by the excitation beams of wavelengths of 1.48 μm and 0.98 μm . This amplifier provides a flat gain characteristic as shown in Fig. 14 when amplifying a wavelength-division-multiplexed optical signal composed of optical signals having wavelengths of 1.535 μm and 1.557 μm .

Figure 20 shows an optical amplifier according to a tenth embodiment of the present invention. The same reference marks as those of Fig. 18 represent like parts.

A branching device 67 separates an optical output signal. The signal is separated by a WDM filter 68 into optical signals having wavelengths of 1.535 μm and 1.557 μm . Photosensors 69 and 70 convert the optical signals into electric signals, respectively. A comparator 71 compares the levels of the electric signals with each other. According to the comparison result, a controller 72 increases the strength of an excitation beam having a wavelength of 1.48 μm emitted from an excitation laser diode 35 or an excitation beam having a wavelength of 0.98 μm emitted from an excitation laser diode 36.

More precisely, if the level of the optical signal of 1.535 μm in wavelength is higher than the level of the other optical signal, the controller 72 controls the laser diode 35 to increase the strength of the excitation beam of 1.48 μm in wavelength. If the level of the optical signal of 1.557 μm in wavelength is higher than the level of the other optical signal, the controller 72 controls the laser diode 36 to increase the strength of the excitation beam of 0.98 μm in wavelength.

This technique minimizes the difference between the

levels of the optical signals.

As explained above, a WDM optical amplifier
embodying the present invention can be designed to control the power of
an excitation beam emitted from an excitation laser diode
5 according to the number of optical signals contained in a
wavelength-division-multiplexed optical input signal,
thereby controlling the output level of the amplifier.
Accordingly, each optical output signal of the amplifier
of the present invention secures a required level at a
10 receiver, thereby minimizing reception errors.

An optical amplifier embodying the present
invention may employ an excitation beam of 1.48- μm -band
wavelength and an excitation beam of a 0.98- μm -band
wavelength to minimize the wavelength dependency of the
15 gain of the amplifier on optical signals of 1.535- μm - and
1.55- μm -band wavelengths, to thereby minimize the
difference between the levels of the optical signals at a
receiver and prevent a reception error.

CLAIMS:

1. An optical amplifier, for amplifying a wavelength-division-multiplexed optical input signal made up of individual optical signals having respective
5 different wavelength-bands, including control means operable to vary the overall gain of the amplifier so that if the number of the said individual optical signals in the said optical input signal is changed, the gain effective in respect of each of the individual
10 optical signals in the changed optical input signal can be restored to a preselected value.

2. An optical amplifier as claimed in claim 1, wherein the said control means comprise an optical output controller connected to operate in dependence
15 upon the output of a reference voltage generator, which output is controlled so as to vary in dependence upon the number of the said individual optical signals in the said optical input signal.

3. An optical amplifier for amplifying a
20 wavelength-division-multiplexed optical input signal composed of optical signals having different wavelengths, the level of the optical output of the amplifier being controlled according to the number of the optical signals.

25 4. The optical amplifier according to claim 3, wherein the level of the optical output of the amplifier is controlled by controlling the strength of an excitation beam.

5. The optical amplifier according to claim 3 or 4
30 wherein the level of the optical output of the amplifier is controlled so that each of the optical signals is kept at a given output level.

6. The optical amplifier according to claim 3,4 or
5 wherein the level of the optical output of the
35 amplifier is controlled according to an external reference input that is set according to the number of

the optical signals.

7. The optical amplifier according to claim 6, wherein the external reference input corresponding to the number of the optical signals is set through a switch.

8. The optical amplifier according to claim 3, 4 or 5 wherein the number of the optical signals is detected, and the level of the optical output of the amplifier is controlled accordingly.

9. The optical amplifier according to claim 8, wherein the input signal is separated, one part of the signal is demultiplexed through a filter into the optical signals, and the optical signals are checked to see if they are present, to thereby determine the number of the optical signals.

10. The optical amplifier according to claim 8, wherein the optical signals are modulated with different frequencies, respectively, and are multiplexed into the wavelength-division-multiplexed optical input signal, the input signal is converted into an electric signal, the electric signal is separated into modulation frequency components, and the modulation frequency components are checked to see if they are present, to thereby determine the number of the optical signals.

11. The optical amplifier according to claim 10, wherein the modulation frequencies are selected to suppress induced Brillouin scattering in an optical fiber that transmits the wavelength-division-multiplexed optical signal.

12. An optical amplifier for amplifying a wavelength-division-multiplexed optical input signal composed of optical signals having different wavelengths, the level of each of the optical signals being detected to control the gain of the amplifier so that the weakest one of the optical signals may have a

required output level and each of the optical signals may secure the required output level or more.

13. The optical amplifier according to claim 12, wherein the input signal is demultiplexed through a
5 filter into the optical signals, the optical signals are converted into electric signals, and the levels of the electric signals are measured to determine the level of each of the optical signals.

14. The optical amplifier according to claim 12,
10 wherein the optical signals are modulated with different frequencies, respectively, and are multiplexed into the wavelength-division-multiplexed optical input signal, the input signal is converted into an electric signal, the electric signal is
15 separated into modulation frequency components, and the levels of the modulation frequency components are measured to determine the level of each of the optical signals.

15. The optical amplifier according to claim 12,
20 13 or 14 further comprising means for detecting the presence of each of the detected optical signals so that any optical signal that is absent is excluded from the control and the optical signals that are present each secure the required output level or more.

25 16. An optical amplifier, for amplifying a wavelength-division-multiplexed optical input signal made up of first and second individual optical signals having first and second different wavelength-bands respectively, comprising an erbium-doped optical fibre
30 through which the said optical input signal is passed and which is subjected simultaneously to first and second different excitation beams of third and fourth different wavelength-bands respectively, the effective gain of the amplifier when subjected to the first
35 excitation beam alone being greater for the first individual optical signal than for the second

individual optical signal, and the effective gain of the amplifier when subjected to the second excitation beam alone being smaller for the first individual optical signal than for the second individual optical signal, so that the simultaneous excitation tends to equalise the respective effective gains for the first and second individual optical-signals.

17. An optical amplifier for amplifying a wavelength-division-multiplexed optical input signal composed of an optical signal of 1.535- μm -band wavelength and an signal of 1.55- μm -band wavelength, by sending the input signal to an erbium-doped optical fiber and by simultaneously applying an excitation beam of 0.98- μm -band wavelength and an excitation beam of 1.48- μm -band wavelength to the optical fiber, when the gain of the amplifier on the optical signal of 1.535- μm -band wavelength is greater than that on the optical signal of 1.55- μm -band wavelength with respect to the excitation beam of 0.98- μm -band wavelength, and when the gain of the amplifier on the optical of 1.535- μm -band wavelength is smaller than that on the optical signal of 1.55- μm -band wavelength with respect to the excitation beam of 1.48- μm -band wavelength.

18. The optical amplifier according to claim 17, wherein the excitation beam of 0.98- μm -band wavelength and the excitation beam of 1.48- μm -band wavelength are multiplexed and applied to the optical fiber to excite the input signal.

19. The optical amplifier according to claim 17, wherein the excitation beam of 0.98- μm -band wavelength and the excitation beam of 1.48- μm -band wavelength are applied to different locations of the optical fiber, respectively, to excite the input signal.

20. An optical amplifier substantially as hereinbefore described with reference to Fig. 10, 11, 12, 13, 15, 16, 17, 18, 19 or 20 accompanying drawings.



Application No: GB 9515583.4
Claims searched: 1 to 15

Examiner: E P Plummer
Date of search: 26 September 1995

**Patents Act 1977
Search Report under Section 17**

Databases searched:

UK Patent Office collections, including GB, EP, WO & US patent specifications, in:

UK Cl (Ed.N): H4B(BK16,BK16D)

Int Cl (Ed.6): H04B

Other:

Documents considered to be relevant:

Category	Identity of document and relevant passage	Relevant to claims
X	GB2280561A NORTHERN TELECOM - whole document & EP0637148A1	1-5,8,10,12,14,15
X	GB2257320A FUJITSU - whole document & US5311347	12
A	EP0617527A1 NORTHERN TELECOM - column 3 line 44ff	

X	Document indicating lack of novelty or inventive step	A	Document indicating technological background and/or state of the art.
Y	Document indicating lack of inventive step if combined with one or more other documents of same category.	P	Document published on or after the declared priority date but before the filing date of this invention.
&	Member of the same patent family	E	Patent document published on or after, but with priority date earlier than, the filing date of this application.



Application No: GB 9515583.4
Claims searched: 16 to 19

Examiner: Dr E P Plummer
Date of search: 29 January 1996

Patents Act 1977
Further Search Report under Section 17

Databases searched:

UK Patent Office collections, including GB, EP, WO & US patent specifications, in:

UK CI (Ed.O): H4B(BK16,BK16D), H1C(CBAA)

Int CI (Ed.6): H04B, H01S

Other:

Documents considered to be relevant:

Category	Identity of document and relevant passage	Relevant to claims
X,P	GB2280561A NORTHERN TELECOM page 5 final paragraph	16 to 19
X	GB2243942A BRITISH TELECOM - figures 4 & 5; page 11 final paragraph to page 15	16,17,19
X	EP0508880A1 ALCATEL - whole document	16 to 19
X	EP0508149A GENERAL INSTRUMENT CORP & US5140546 - whole document	16 to 19
X	EP0440024A STANDARD ELEKTRIK LORENZ & US5111334 - whole document	16

X	Document indicating lack of novelty or inventive step	A	Document indicating technological background and/or state of the art.
Y	Document indicating lack of inventive step if combined with one or more other documents of same category.	P	Document published on or after the declared priority date but before the filing date of this invention.
&	Member of the same patent family	E	Patent document published on or after, but with priority date earlier than, the filing date of this application.