

J. H. ZEHRING
 BROILING STOVE.
 APPLICATION FILED JAN. 13, 1908.

898,814.

Patented Sept. 15, 1908.

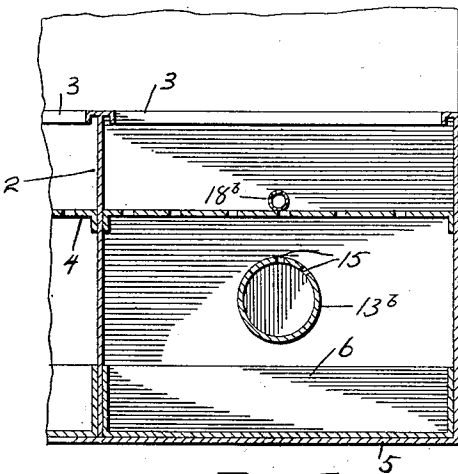
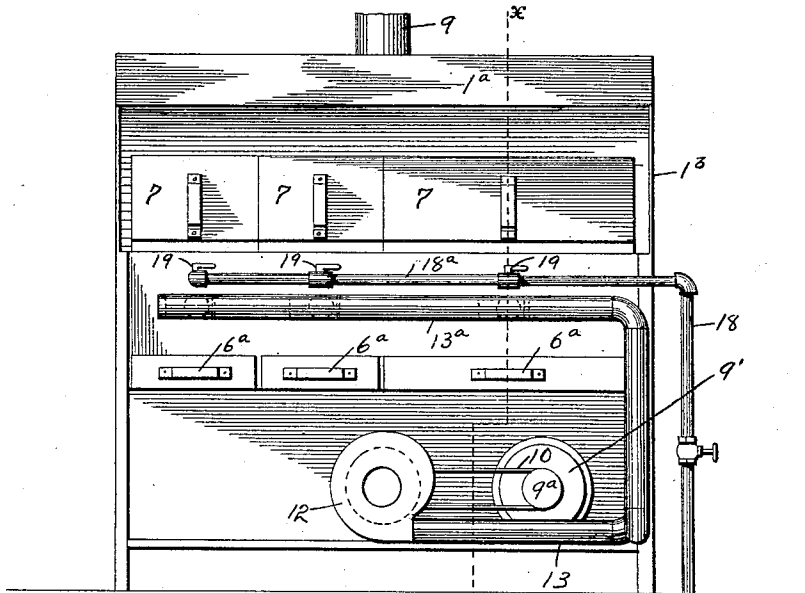

Fig. 3.

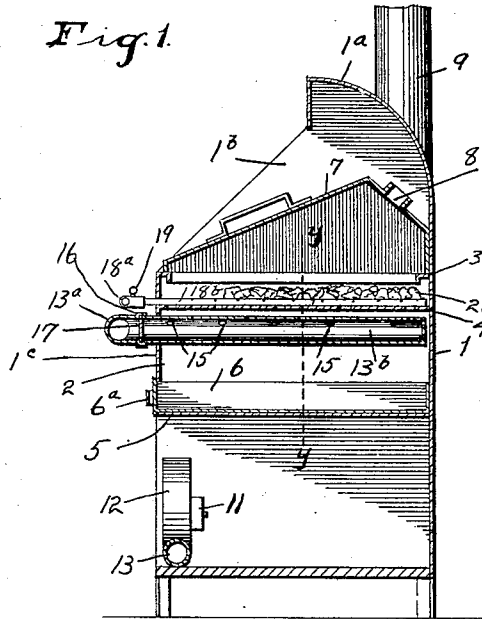

Fig. 2.

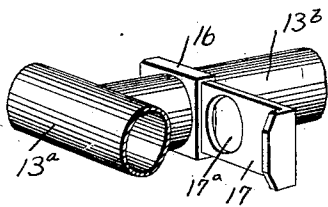

Fig. 4.

Witnesses.

Carl Stoughton.
 A. L. Phelps

By

Inventor
 Julius H. Zehring
 C. C. Shepherd
 Attorney

UNITED STATES PATENT OFFICE.

JULIUS H. ZEHRING, OF COLUMBUS, OHIO.

BROILING-STOVE.

No. 898,814.

Specification of Letters Patent.

Patented Sept. 15, 1908.

Application filed January 13, 1908. Serial No. 410,592.

To all whom it may concern:

Be it known that I, JULIUS H. ZEHRING, a citizen of the United States, residing at Columbus, in the county of Franklin and State of Ohio, have invented certain new and useful Improvements in Broiling-Stoves, of which the following is a specification.

My invention relates to broiling stoves and the objects of my invention are to provide a broiling stove of improved construction and operation wherein means are provided for imparting to the meats to be broiled, a high degree of heat free from smoke and flame and by means of which the broiling of meats may be rapidly and effectively accomplished. These objects I accomplish in the manner illustrated in the accompanying drawing, in which:

Figure 1 is a front elevation of my improved broiling stove, Fig. 2 is a sectional view on two planes as indicated by dotted line $x-x$ on Fig. 1, Fig. 3 is an enlarged sectional view on line $y-y$ of Fig. 2, and, Fig. 4 is a detail view in perspective illustrating a valve or damper construction which I employ in connection with the air conducting pipes in the manner hereinafter described.

Similar numerals refer to similar parts throughout the several views.

In carrying out my invention I provide an upright stove casing or body 1, preferably of sheet metal. As indicated at 1^a, the back of the stove casing is carried upward above the main body thereof and terminates in a forwardly extending hood-like extension, the sides 1^b of which incline to the front of the stove body. By means of vertical partitions arranged at suitable distances from each other, one of which is indicated at 2, the stove body is divided into three compartments or sections and at the top or upper end of each of these sections is provided an inwardly and thence downwardly flanged broiler supporting frame 3. Below each of these frames 3 is a horizontal grating or openwork partition 4 and at a suitable distance beneath each of the latter is provided a second horizontal partition plate 5, the latter forming a support for ash receiving drawers or pans 6, there being one of these drawers or pans shown in the drawing beneath each of the grates 4, the outer ends of said pans which pass through openings in the front plate 1^c of the stove casing, having suitable handles 6^a.

Upon each of the frames 3 above each of

the compartments of the stove, is adapted to be removably supported a cover 7, each of said covers having comparatively short vertical walls and having its upper side preferably of the angular form shown in the drawing. Through the rear member of the angular top of each of the covers 7, is formed an outlet opening 8 which has a short neck extension, the latter terminating within the rear portion of the hood 1^a. Said hood in its rear portion is also provided with an outlet pipe shown at 9.

Within the lower portion of the stove casing, I provide a suitable form of electric motor which is indicated in outline at 9'. This motor has its driving wheel 9^a connected by a belt 10 with the driving wheel 11 of a suitable form of rotary air fan contained in a fan casing 12, which is also supported within the stove body. From the fan casing leads an air pipe 13, the latter extending upward and terminating in a horizontal arm 13^a which extends, as shown, in front of the stove body above the ash pans. The pipe arm or member 13^a has extending at right angles therefrom through the stove front 1^c, pipe arms 13^b one of the latter extending beneath each of the grates 4 and having perforations 15 formed, as shown, in its upper side.

As shown more clearly in Figs. 2 and 4 of the drawing, I provide each of the pipe arms 13^b with an intersecting valve casing 16 in which is adapted to fit movably a slide valve 17, the latter having an opening 17^a therein to permit of the establishment when desired of communication between those sections of the pipe 13^b which are on opposite sides of the valve casing 16. 18 represents a gas supply pipe which leads from a suitable source and which has a horizontal portion 18^a extending in front of the stove casing. This pipe arm 18^a has branch burner arms 18^b extending therefrom immediately above each of the grates 4 and the entrance of gas from the pipe section 18^a to said arms is controlled by the usual valves 19.

In utilizing my invention the meat to be broiled is supported in a suitable broiler upon the desired one of the frames 3. Upon the grate frame 4 beneath said broiler is designed to be supported a desirable quantity of charcoal or similar non-flame producing fuel 20. Prior to placing the broiler on the frame 3 and covering the same with one of the covers 7, the gas from the pipe 18 is turned into the proper burner arm 18^b and ignited, the flame

therefrom passing upward through and heating the charcoal. The charcoal having been properly ignited from the gas flame, the gas from the pipe arm 18^b is cut off and an electric current from suitable connections turned into the motor 9', resulting in the rapid rotation of the fan contained in the case 12 and in the forcing of air under pressure through the air conducting pipe. That valve 17 of the air pipe arm 13^b which extends beneath the burning charcoal, being open, it is obvious that air will be forced rapidly through the openings 15 of said air pipe arm and through the burning charcoal, resulting in a blast of intensely heated air being driven against the meat contained in the broiler, which is upon the frame 3. It is obvious that the products of combustion and fumes from the broiling meat, may pass outward through the proper cover outlet 8 and thence through the hood outlet pipe 9.

From the operation described, it will be understood that a rapid broiling action will be imparted to the meat and that this will be accomplished without the meat being subjected to the action of flame or smoke.

It is obvious that a broiling stove constructed and operated as above described, will be of great utility in the kitchens of restaurants, hotels, clubs etc., and that the same may be produced and operated at a reasonable cost.

What I claim, is:

1. In a broiling stove, the combination with a stove body, of a frame adapted to support a broiler, a support for non-flaming fuel located beneath said frame, a valve con-

trolled gas pipe adjacent said support and serving to impart an initial heating to the non-flaming fuel, an air discharge pipe supported beneath said fuel support, and means for forcing air through said air discharge pipe.

2. In a broiling stove, the combination with a stove body, said body having an opening in its upper side over which a meat containing broiler is adapted to be supported, of a chamber below said opening adapted to contain non-flaming fuel, a valve controlled gas burner adapted to discharge a gas flame into said fuel chamber, an air discharging pipe adjacent to said fuel chamber, a motor operated fan, and a conductor leading from the casing of said fan to said air discharging pipe.

3. In a broiling stove, the combination with a stove body comprising a plurality of compartments, means for supporting a broiler above each compartment, and a removable cover for each compartment having an outlet therein, of a grate in each compartment adapted to support non-flaming fuel, a gas burner lying adjacent said grate and serving to impart an initial heating to the non-flaming fuel, and means for discharging air under pressure through the openings of the grate and through the fuel thereon.

In testimony whereof I affix my signature in presence of two witnesses.

JULIUS H. ZEHRING.

Witnesses:

L. CARL STOUGH, A. L. PHELPS.