



US00D767494S

(12) **United States Design Patent**
Tada

(10) **Patent No.:** **US D767,494 S**

(45) **Date of Patent:** **** Sep. 27, 2016**

(54) **ELECTRICAL CONNECTOR**

2015/0340815 A1* 11/2015 Gao H01R 13/6581

2016/0033198 A1* 2/2016 Hsiao 439/607.01

F26B 3/28
439/485

(71) Applicant: **Japan Aviation Electronics Industry, Limited**, Tokyo (JP)

(72) Inventor: **Takashi Tada**, Tokyo (JP)

FOREIGN PATENT DOCUMENTS

(73) Assignee: **Japan Aviation Electronics Industry, Limited**, Tokyo (JP)

JP 1445437 S 7/2012

JP 1445438 S 7/2012

JP 1445439 S 7/2012

JP 1445440 S 7/2012

JP 1445441 S 7/2012

JP 1445442 S 7/2012

(**) Term: **15 Years**

* cited by examiner

(21) Appl. No.: **29/528,168**

(22) Filed: **May 27, 2015**

Primary Examiner — Daniel Bui

(30) **Foreign Application Priority Data**

(74) *Attorney, Agent, or Firm* — aCermak Nakajima & McGowan LLP; Tomoko Nakajima

Dec. 12, 2014 (JP) 2014-027753

(51) **LOC (10) Cl.** **13-03**

(57) **CLAIM**

The ornamental design for an electrical connector, as shown.

(52) **U.S. Cl.**

USPC **D13/147**

DESCRIPTION

(58) **Field of Classification Search**

USPC D13/147, 154, 184, 199

CPC H01R 13/00; H01R 24/00; H01R 13/52;

H01R 13/5202; H01R 13/521; H01R 24/76

See application file for complete search history.

FIG. 1 is a front elevational view of an electrical connector showing my new design;

FIG. 2 is a top plan view thereof;

FIG. 3 is a right side elevational view thereof;

FIG. 4 is a left side elevational view thereof;

FIG. 5 is a rear elevational view thereof; and

FIG. 6 is a bottom plan view thereof.

FIG. 7 is a front and top perspective view thereof;

FIG. 8 is a rear and top perspective view thereof;

FIG. 9 is a front and bottom perspective view thereof; and,

FIG. 10 is a rear and bottom perspective view thereof.

(56) **References Cited**

U.S. PATENT DOCUMENTS

D516,519 S * 3/2006 Nishio D13/147

D618,623 S * 6/2010 Peng D13/147

D744,430 S * 12/2015 Yokoyama D13/147

2015/0244101 A1 * 8/2015 Chien H01R 13/5202
439/271

1 Claim, 10 Drawing Sheets

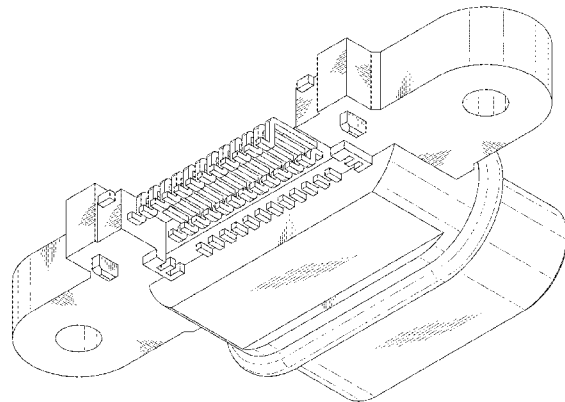
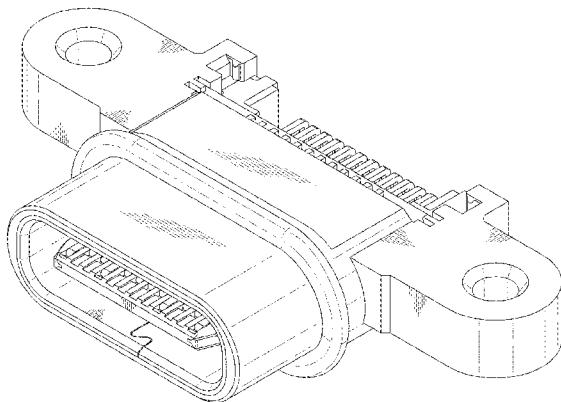

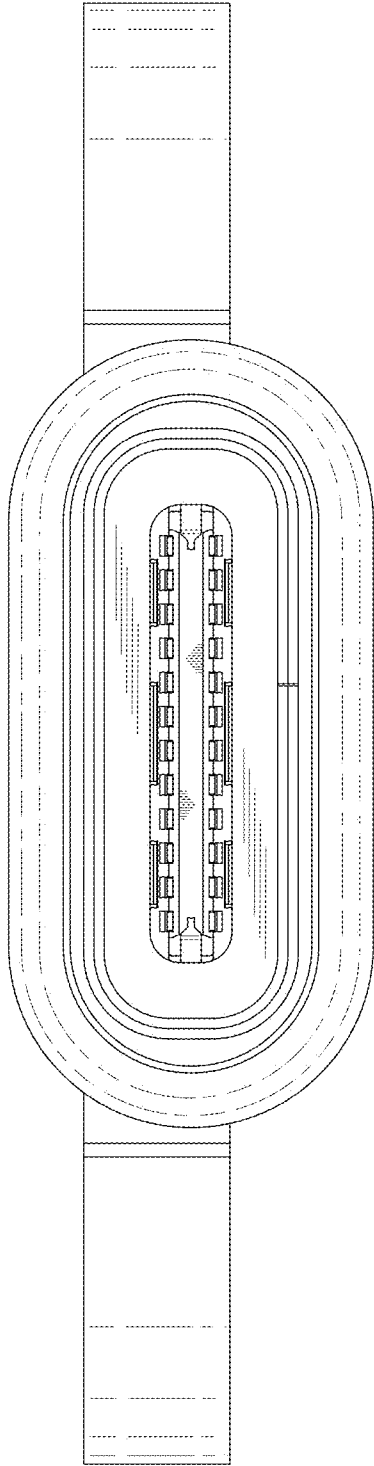

FIG.1

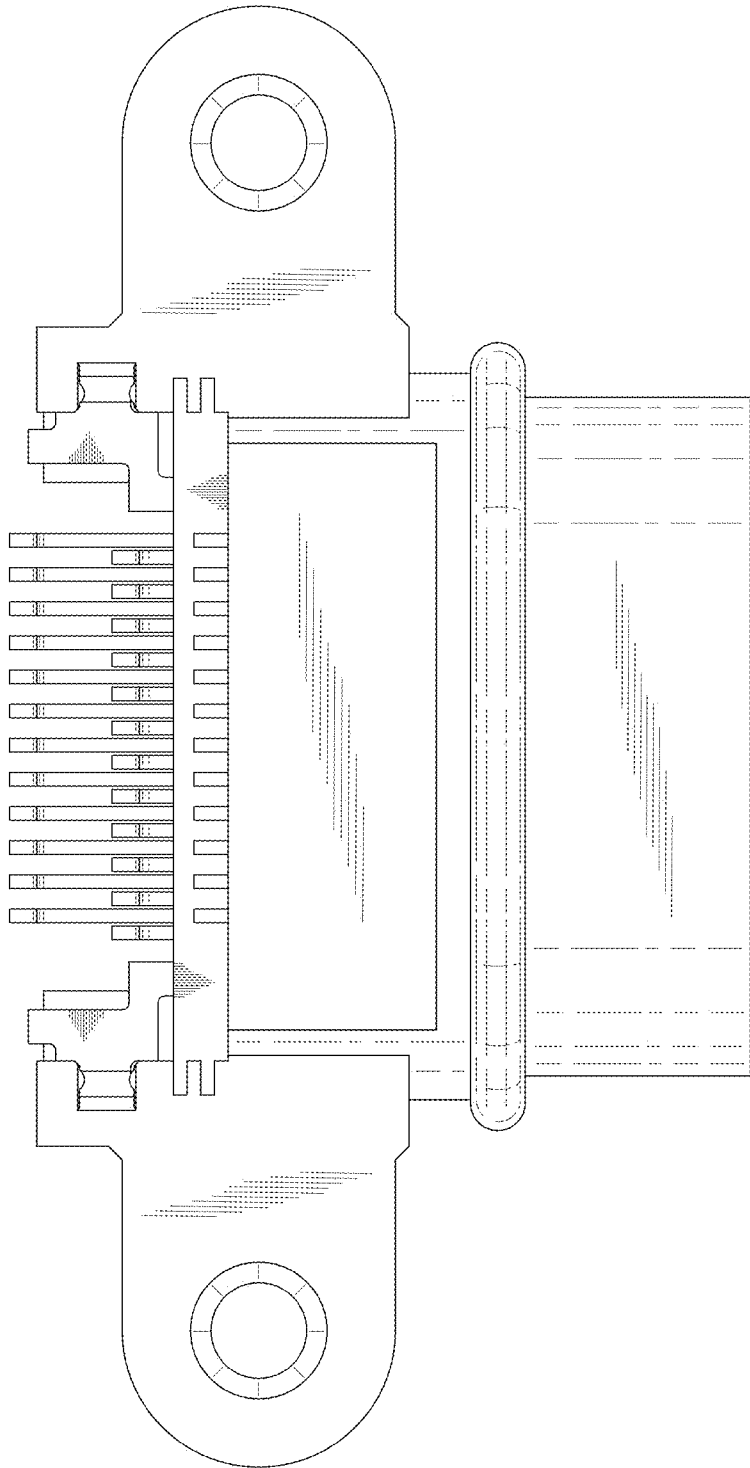

FIG.2

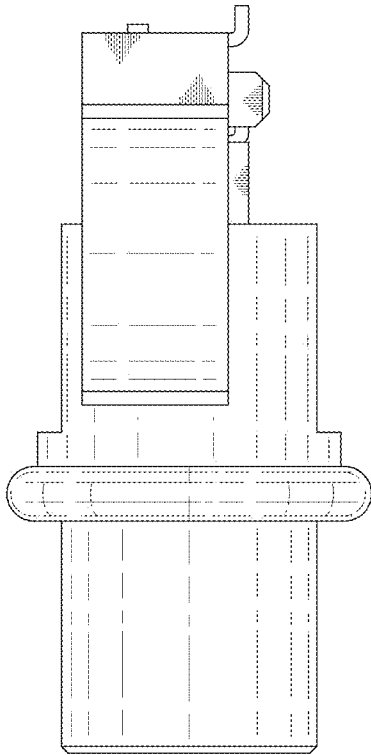

FIG.3

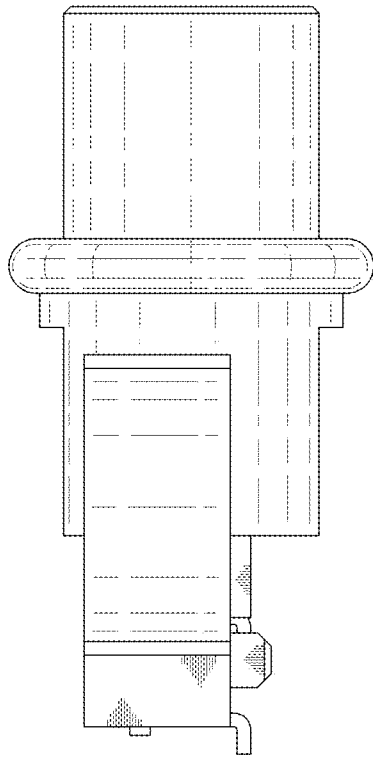

FIG.4

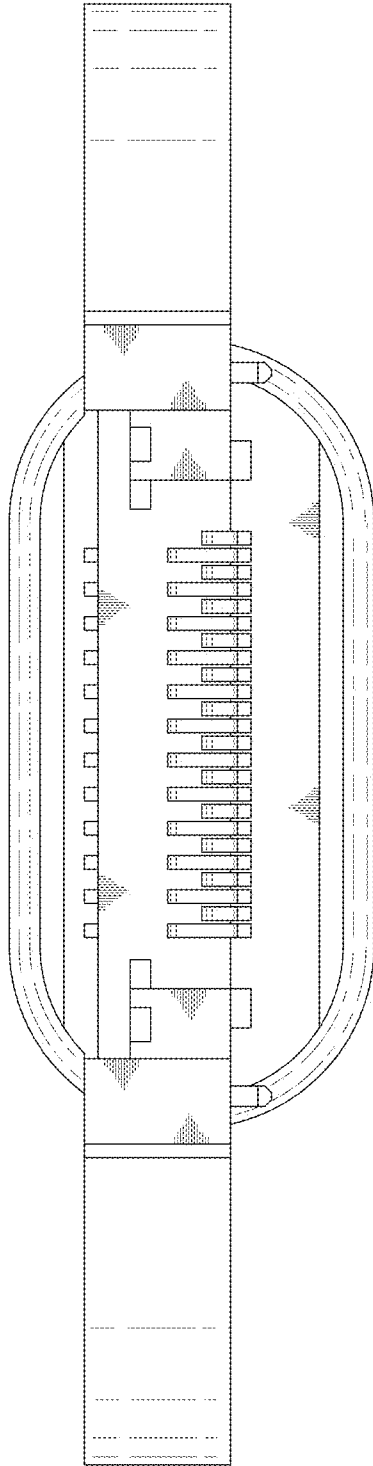

FIG.5

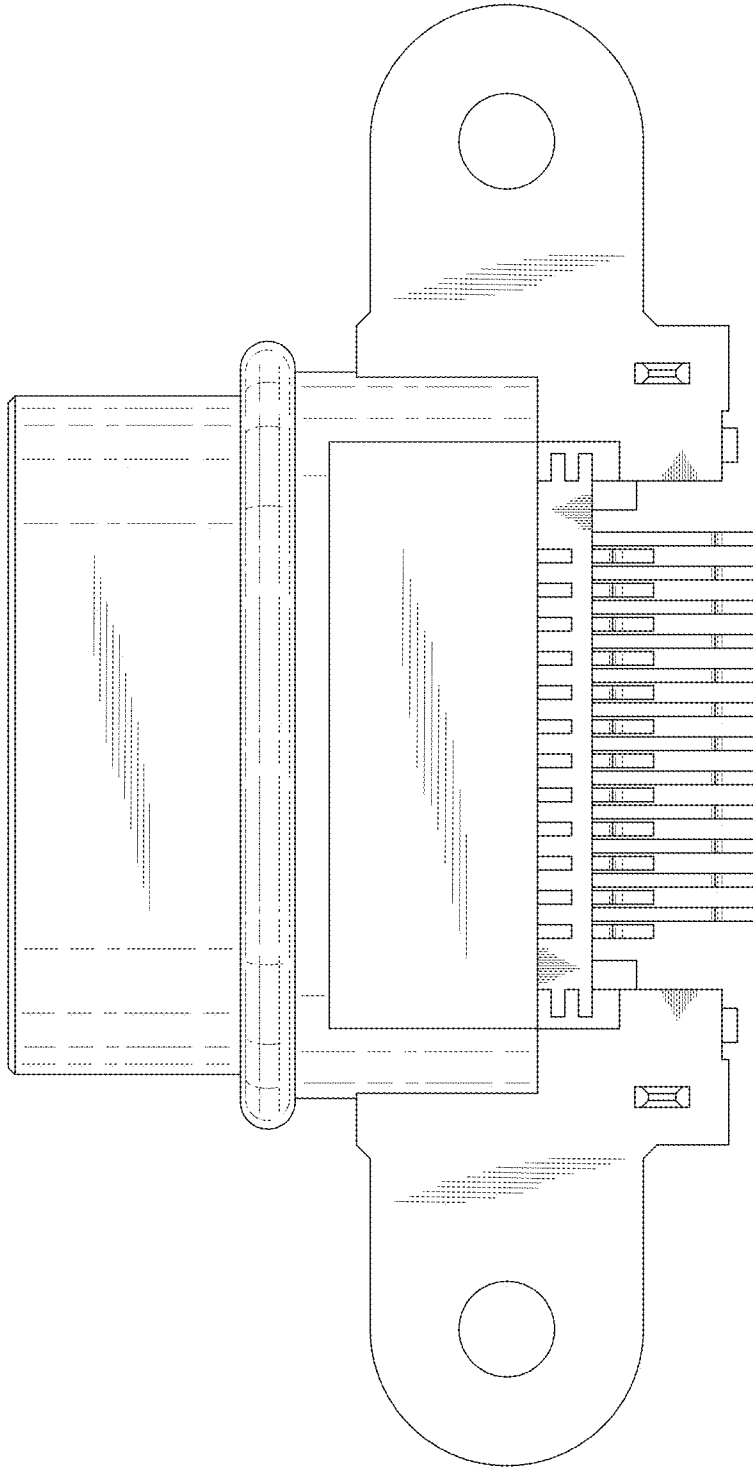

FIG.6

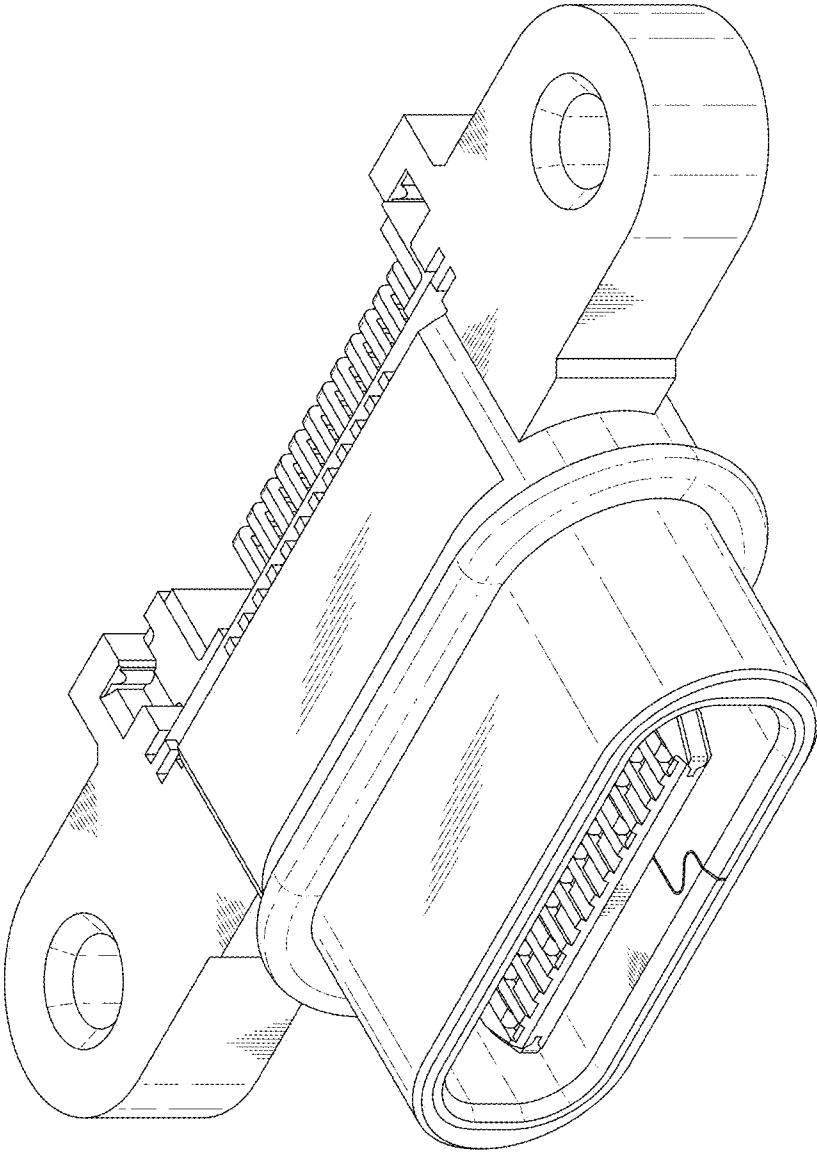

FIG.7

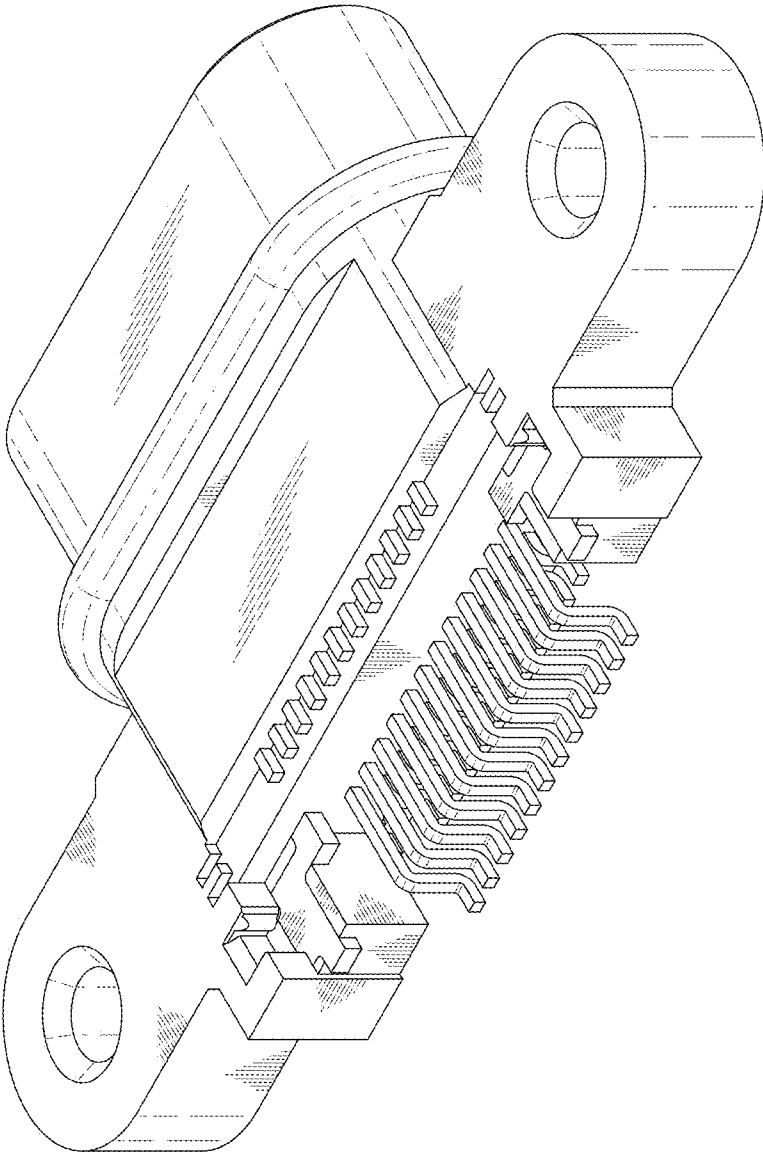

FIG. 8

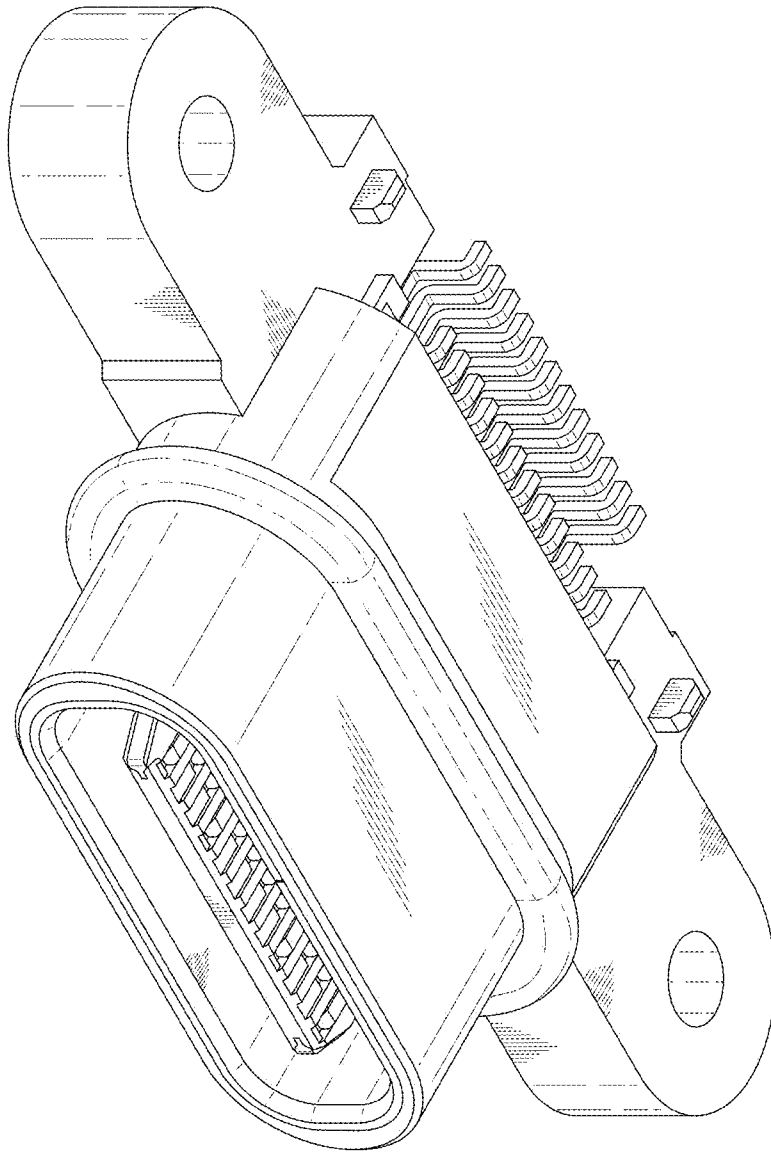

FIG. 9

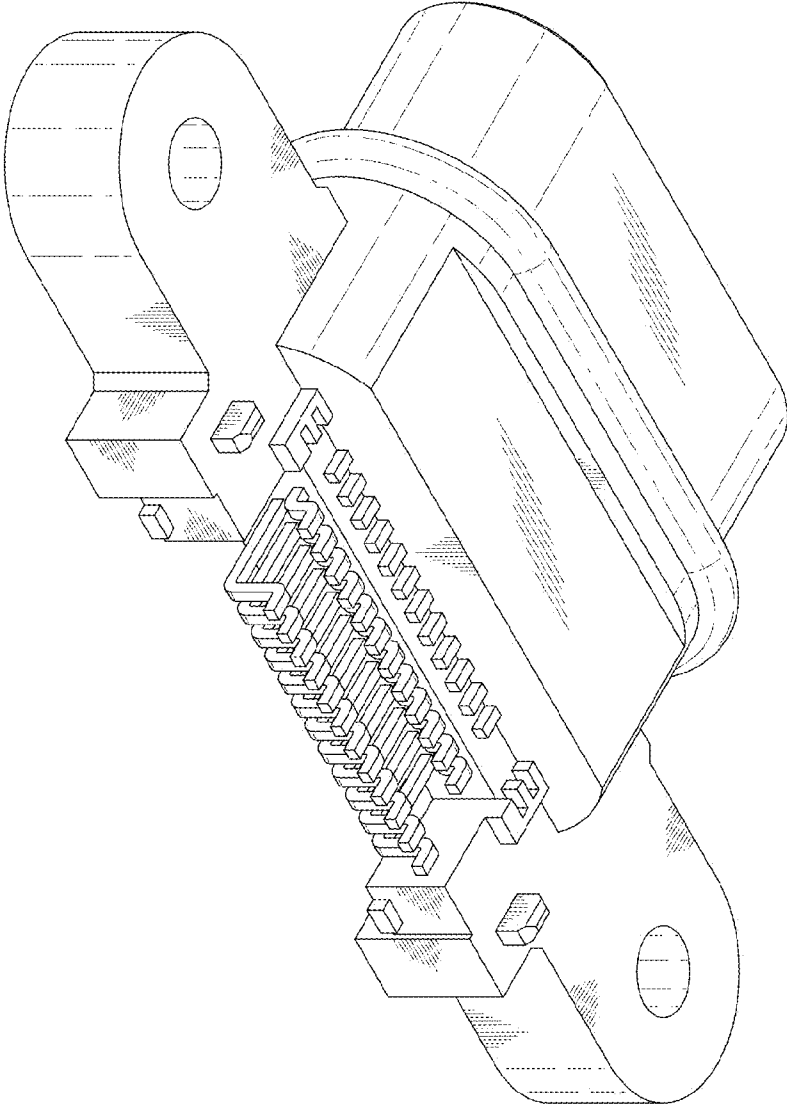

FIG.10