

No. 661,740.

Patented Nov. 13, 1900.

H. KRUSCHWITZ.
CHIME OF BELLS.

(Application filed May 19, 1899.)

(No Model.)

2 Sheets—Sheet 1.

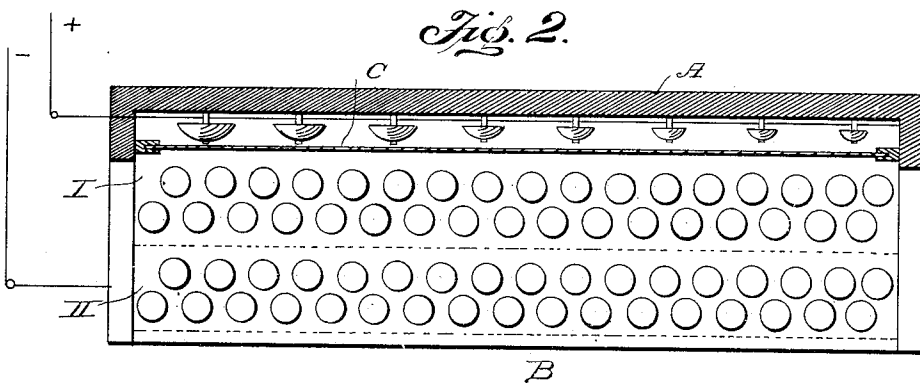
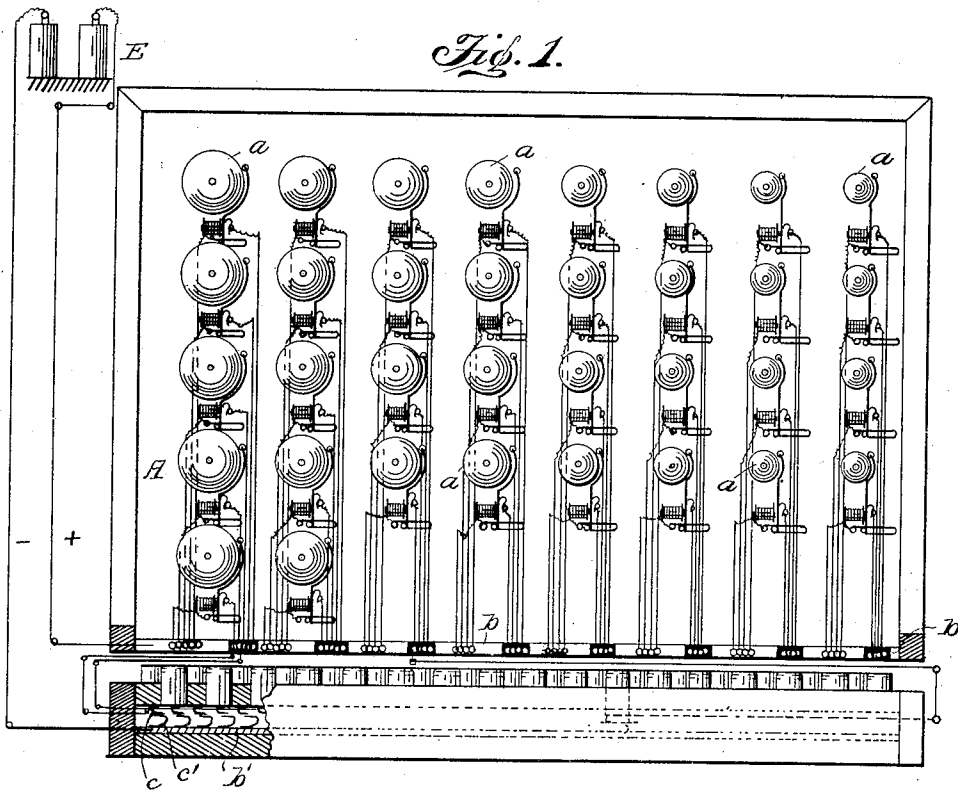

WITNESSES
E. W. Hart.
Geo. C. Hopkins

INVENTOR
Hermann Kruschwitz
by *Geo. A. Richmond*
his Attorney

No. 661,740.

Patented Nov. 13, 1900.

H. KRUSCHWITZ.
CHIME OF BELLS.

(Application filed May 19, 1899.)

(No Model.)

2 Sheets—Sheet 2.

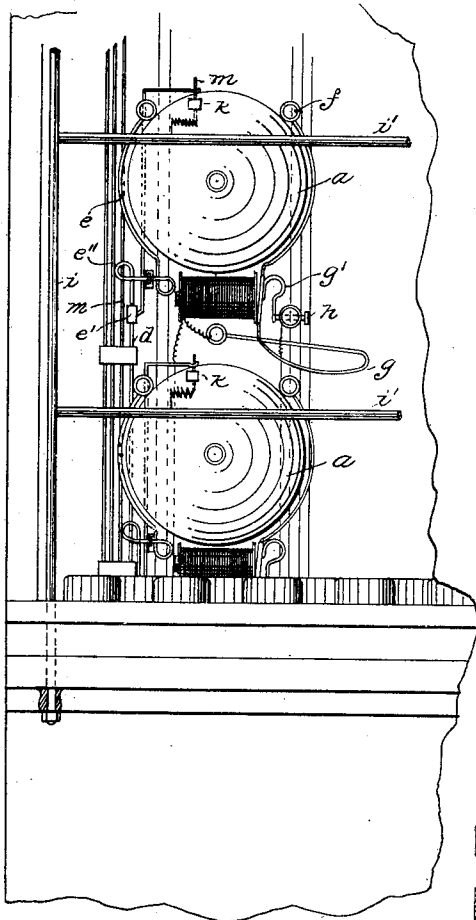

Fig. 3.

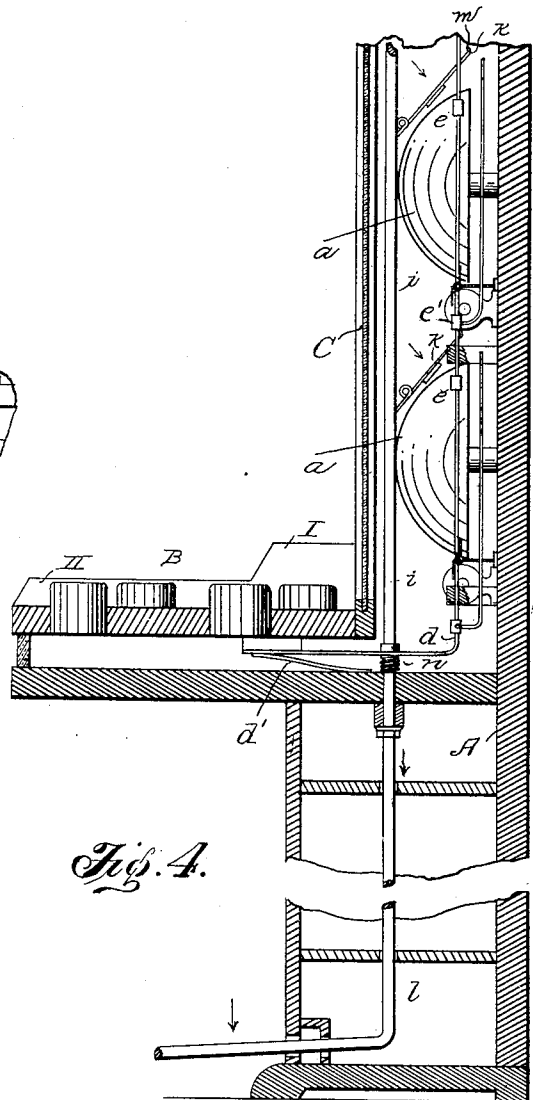

Fig. 4.

WITNESSES

C. W. Hall
Jas. C. Hopkins

INVENTOR

Hermann Kruschwitz
by *Jas. A. Richmond*
his Attorney

UNITED STATES PATENT OFFICE.

HERMANN KRUSCHWITZ, OF NEU-UNTERMHAUS, GERMANY.

CHIME OF BELLS.

SPECIFICATION forming part of Letters Patent No. 661,740, dated November 13, 1900.

Application filed May 19, 1899. Serial No. 717,512. (No model.)

To all whom it may concern:

Be it known that I, HERMANN KRUSCHWITZ, a subject of the Emperor of Germany, residing at Neu-Untermhaus, near Gera, Germany, have invented certain new and useful Improvements in Chimes of Bells; and I do hereby declare the following to be a full, clear, and exact description of the invention, such as will enable others skilled in the art to which it appertains to make and use the same.

The present invention relates to musical bells, the object being to provide an instrument of this character having an electrical action and a manually-operated striker for each bell and a damper device, as hereinafter described, and defined in the claim.

In order that the invention may be clearly understood, reference will be had to the drawings accompanying and forming a part of this specification, wherein—

Figure 1 is an elevation showing the general arrangement of the bells, electric circuits, and the keyboard, the latter appearing partly in section to disclose the electrical connections. Fig. 2 is a section through the bell-frame, the keyboard appearing in plan. Fig. 3 is a detail of the bells, showing the actuating mechanism and damper device in their relative positions; and Fig. 4 is a vertical cross-section through the instrument.

Like letters of reference denote like parts in the several views.

The frame of this apparatus has the general form and appearance of an upright piano and comprises a bell-casing and keyboard. The vertically-extending rear plate or frame A carries a plurality of properly-tuned bells *a*, arranged in series to harmonize with one another. The keyboard B has two sets of keys I II, the former of which is adapted to mechanically control each bell and the latter is adapted to control said bells electrically.

The means for sounding the bells electrically are as usual, except that but one electromagnet for each bell is employed. The armature consists of a wire *g*, secured to a binding-post in circuit with the magnet, which wire extends horizontally a short distance, is bent to form a loop, then extends upwardly in position to be attracted by the electromagnet, and terminates in the striker *f*. The armature has the spring *g'*, bearing

against the contact-screw *h*. From this contact-screw the circuit extends over insulated parts of metal rail *b* to the contact-springs *c* of each of the keys, the latter taking the general form of push-buttons in the present case. The opposite contact-springs *c'* are fastened on metal rail *b'*, both of said rails being in circuit with battery E or other source of electrical energy, so that as the wires to the left are connected with the metal rail *b* the circuit is completed by depressing one or more of the keys, as shown dotted at the right-hand side of Fig. 1. By depressing keys II the bells will ring continuously for any desired length of time.

It is sometimes desirable to have in addition to the continuous stroke a means for obtaining a single stroke of the bell, and to this end I provide a second striker *e* opposite striker *f*. Said striker consists of a suitably-curved wire *e*, terminating at the top in a hammer and having its lower portion bent as a loop and passed through an eye and again similarly bent at *e''*, as before, to form an S and its end connected to a vertical rod *d* by a threaded coupling *e'*. Said rod *d* extends downwardly through suitable staples or supports, and its lower extremity is bent at a right angle to pass between the bent stiff spring *d'* of keys I and the keyboard, Fig. 4, whereby when any of said keys are depressed the rods *d* are drawn downwardly and hammer *e* by virtue of its spring *e''* is made to strike the bell. Said bells and the operating mechanism therefor are protected from injury by a glass partition C, forming the front of the bell-casing.

The damper device is shown in Figs. 3 and 4 and embodies a spring-pressed frame operated by pedal-levers. The frame consists of vertical rods *i*, passing up into the bell-case and united by transverse rods *i'*, the latter carrying the angularly-arranged dampers *k*, consisting of spring-wires held normally out of contact with the bells by springs *n* on rods *i*, as shown. The rods *i* extend through suitable guides to the base of the instrument, where they are connected with pedal-levers for throwing the dampers *k* into and out of action. The strikers *e* have their upper ends bent laterally and terminated in hooks adapted to engage the projections *m* of the dam-

pers *k*, with the object to dampen or deaden the sounding of the bells operated by the keys *I*.

Having thus described my invention, what I claim, and desire to secure by Letters Patent of the United States, is—

In a musical instrument of the character described, a soundboard carrying a plurality of electric bells in harmony, electrical means for causing a continuous sounding of one or more of said bells and mechanical means for causing a single stroke of said bells, a shifting frame, dampers carried thereby to deaden the sound of the bells, pedal-levers for actuating the dampers, a battery, a contact-plate *b*, electrical connections between said plate

and the battery and bell mechanism, a keyboard having two sets of keys, electrical connections between each key of one of said sets and the contact-plate *b*, a second plate *b'* in electrical connection with the battery whereby the circuit through a bell mechanism is completed by depressing a key, a pulling connection between the other set of keys and the bells, and a casing for said element substantially as described.

In testimony whereof I affix my signature in presence of two witnesses.

HERMANN KRUSCHWITZ.

Witnesses:

GUSTAVE RURKART,
A. BRÄUTIGAM.