



INTERNATIONAL APPLICATION PUBLISHED UNDER THE PATENT COOPERATION TREATY (PCT)

<p>(51) International Patent Classification <sup>5</sup> : <b>G01D 5/48</b></p>	<p><b>A1</b></p>	<p>(11) International Publication Number: <b>WO 94/27117</b> (43) International Publication Date: 24 November 1994 (24.11.94)</p>
<p>(21) International Application Number: PCT/GB94/00992 (22) International Filing Date: 9 May 1994 (09.05.94) (30) Priority Data: 9309975.2 14 May 1993 (14.05.93) GB (71) Applicant (for all designated States except US): MULTILOP LIMITED [GB/GB]; 20 First Avenue, Watford, Hertfordshire WD2 6PZ (GB). (72) Inventor; and (75) Inventor/Applicant (for US only): VAHRMAN, Richard [GB/GB]; 20 First Avenue, Watford, Hertfordshire WD2 6PZ (GB). (74) Agent: MATHISEN, MACARA &amp; CO.; The Coach House, 6/8 Swakeleys Road, Ickenham, Uxbridge UB10 8BZ (GB).</p>	<p>(81) Designated States: AU, CA, GB, JP, US, European patent (AT, BE, CH, DE, DK, ES, FR, GB, GR, IE, IT, LU, MC, NL, PT, SE).  Published With international search report.</p>	

(54) Title: A SECURITY SYSTEM

(57) Abstract

A security system for testing for exposure of the contents (4) of a container (3) to a predetermined physical stimulus. The system has a sensor (1), for example a pressure sensor, and a tag (2) in the form of a r.f. transponder which are both placed within the container (3). The transponder transmits data representative of the output state of the sensor (1) in response to an interrogation signal for a transceiver (5) outside the container (3), without the container having to be opened.

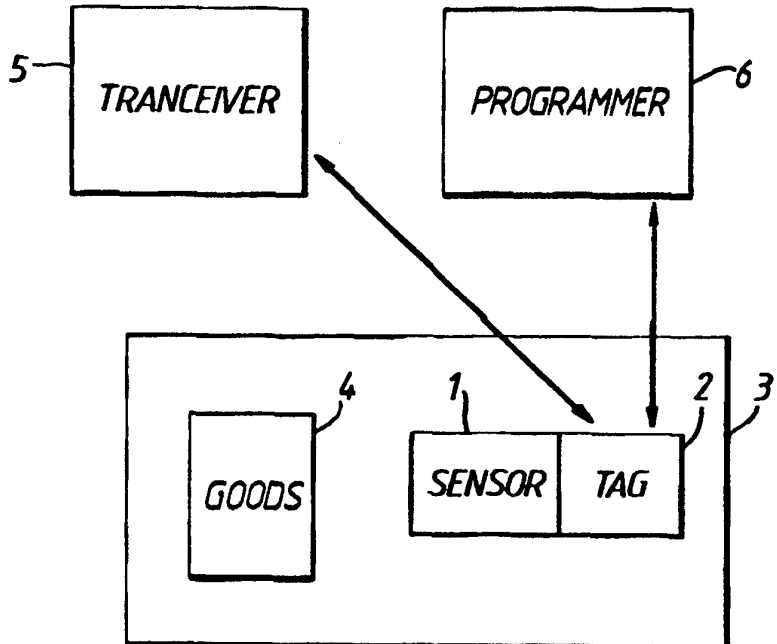

**FOR THE PURPOSES OF INFORMATION ONLY**

Codes used to identify States party to the PCT on the front pages of pamphlets publishing international applications under the PCT.

AT	Austria	GB	United Kingdom	MR	Mauritania
AU	Australia	GE	Georgia	MW	Malawi
BB	Barbados	GN	Guinea	NE	Niger
BE	Belgium	GR	Greece	NL	Netherlands
BF	Burkina Faso	HU	Hungary	NO	Norway
BG	Bulgaria	IE	Ireland	NZ	New Zealand
BJ	Benin	IT	Italy	PL	Poland
BR	Brazil	JP	Japan	PT	Portugal
BY	Belarus	KE	Kenya	RO	Romania
CA	Canada	KG	Kyrgystan	RU	Russian Federation
CF	Central African Republic	KP	Democratic People's Republic of Korea	SD	Sudan
CG	Congo	KR	Republic of Korea	SE	Sweden
CH	Switzerland	KZ	Kazakhstan	SI	Slovenia
CI	Côte d'Ivoire	LI	Liechtenstein	SK	Slovakia
CM	Cameroon	LK	Sri Lanka	SN	Senegal
CN	China	LU	Luxembourg	TD	Chad
CS	Czechoslovakia	LV	Latvia	TG	Togo
CZ	Czech Republic	MC	Monaco	TJ	Tajikistan
DE	Germany	MD	Republic of Moldova	TT	Trinidad and Tobago
DK	Denmark	MG	Madagascar	UA	Ukraine
ES	Spain	ML	Mali	US	United States of America
FI	Finland	MN	Mongolia	UZ	Uzbekistan
FR	France			VN	Viet Nam
GA	Gabon				

## A SECURITY SYSTEM

### FIELD OF THE INVENTION

This invention relates to a security system for testing for exposure of the contents of a container to a predetermined physical stimulus.

### BACKGROUND OF THE INVENTION

A problem associated with storing or transporting goods in a container is that of determining whether or not the container has been opened or if the goods have been exposed to adverse conditions which might cause their damage or deterioration.

For example, if precious items, such as diamonds, are placed in a container, whether for storage or transportation, it might be possible for fraudulent personnel to open the container either to remove some of the items or replace them with items of inferior quality. In such situations, it would be desirable to determine whether or not the container has been opened.

In the case of perishable goods, or goods which are easily damaged, for example organ transplants or sensitive electronic equipment, it may be important to know whether the goods have been exposed to adverse

environmental conditions. It may not always be immediately apparent to a recipient of the goods, or a person retrieving the goods from storage, that the goods have been damaged. The goods may later fail or cease to function satisfactorily.

#### SUMMARY OF THE INVENTION

According to the invention there is provided a security system for testing for exposure of the contents of a container to a predetermined physical stimulus, the security system comprising sensor means sensitive to the predetermined physical stimulus, the sensor means being located within the container and having an output state which can be determined from outside the container.

A system according to the invention allows the contents of the container to be tested for exposure to the predetermined physical stimulus without the container having to be opened.

Preferably, the security system comprises transmission means for transmitting data representative of the output state of the sensor means in response to an interrogation signal.

The output state of the sensor means may be a continuously updated value of the physical stimulus

sensed by the sensor means. Thus, the value of the physical stimulus can be determined at the moment of reading.

Alternatively, the output state of the sensor means is indicative of whether said predetermined physical stimulus has crossed or has not crossed a predetermined threshold value, and in this case the transmitted data would not be updated even if the threshold was crossed again. Thus, the transmitted data would provide an indication that the physical stimulus has crossed the predetermined threshold value, indicating that the container has been opened or that the contents of the container have been exposed to potentially damaging conditions. The transmission means may be resettable to permit it to be used again after the threshold had been crossed, or the transmission means may be a one-use device that cannot be reset.

For reasons of economy, the transmission means is, preferably, a passive device which is powered by energy received from an interrogating transceiver, and may be in the form of a transponder, such as an r.f. transponder.

The transmission means may include data storage means for storing identification data.

The transmission means may comprise a first data storage means storing first identification data, and a second data storage means storing second identification data; and said sensor means causes the transmission means to transmit either the first or the second identification data in dependence on the output state of the sensor.

The transmission means may have more than two said data storage means, each storing respective identification data, and said sensor means causes the transmission of identification data from a respective said data storage means in dependence on the output state of the sensor.

The physical stimulus to be sensed may be pressure, temperature, light, magnetic flux, humidity or any other parameter.

In the case of valuable items, such as diamonds, the container in which they are placed may be a sealed container having a pressure differential between its interior and exterior, and the physical stimulus sensed by the sensor means would then be pressure. If the container's seal is broken, the resulting pressure change will be sensed by the sensor means.

#### DESCRIPTION OF THE DRAWINGS

Embodiments of the invention are now described, by way

of example only, with reference to the accompanying drawings, in which:

Figure 1 is a schematic representation of a security system in accordance with the invention;

Figure 2 is a block circuit diagram showing one embodiment of a sensor and tag forming part of the security system of Figure 1, and

Figure 3 is a block circuit diagram showing another embodiment of a sensor and tags forming a part of the security system of Figure 1.

#### DESCRIPTION OF PREFERRED EMBODIMENTS

Referring to the drawing, the security system includes a sensor 1 sensitive to a predetermined physical stimulus, e.g. pressure, temperature, humidity etc, and a tag 2 in the form of an r.f. transponder. The sensor 1 and tag 2 form a unit which is placed within a container 3 together with goods 4 being transported or stored.

The r.f. transponder, which may be of known kind (e.g. the TIRIS tag manufactured by Texas Instruments) is a passive device which transmits data in response to a r.f. interrogation signal from a transceiver 5.

Figure 2 shows one embodiment of the r.f. transponder and its associated sensor 1.

The r.f. transponder comprises an antenna 21 which is tuned to the frequency of the r.f. interrogation signal by means of a tuning capacitor 22. The r.f. interrogation signal is transmitted by transceiver 5 as a pulse of r.f. energy which is received by antenna 21, rectified by a diode 23 and stored temporarily in a storage capacitor 24. A power circuit 25 detects when the interrogation pulse has ended and, in response to such detection, causes capacitor 24 to discharge, whereby the stored energy is retransmitted as a r.f. signal via the tuned antenna 21. A control circuit 26 modulates the frequency of the retransmitted signal in accordance with both the current output state of sensor 1 and a unique identification code which is permanently stored in a memory 27. The resultant frequency-modulated signal is received by transceiver 5 where it is de-modulated in order to recover the output state of sensor 1 and the identification code of the tag 2.

In use, the sensor 1 and tag 2 are placed inside container 3 together with the goods 4. The tag may then be initiated, in known manner, by means of a signal transmitted by a tag-programmer 6, and subsequently



interrogated, in the afore-described manner, to determine the output state of the sensor and the identification code of the tag.

If the goods 4 are valuable items; for example, diamonds, the container 3 may conveniently be a vacuum-sealed plastics material bag. In this case, sensor 1 would be a pressure sensor having an output state which changes if the pressure in the bag increases due to the vacuum-seal being broken.

By way of illustration, the identification code stored in memory 27 of the tag may represent the number 14328, whereas the transmitted data may represent either the number 114328 or 014328 depending on the output state of the sensor 1 - if the leading numeral is "1" this represents the existence of a vacuum indicating that the seal has not been broken, whereas a "0" represents a higher pressure indicating that the seal has been broken.

If a relatively high degree of security is required the tag 2 and sensor 1 may have a non-retriggerable action after initial activation by the tag-programmer 6. That is to say, if the seal is broken and the vacuum destroyed the leading numeral will remain at "0" even if the vacuum is subsequently restored during resealing.

The tag 2 and sensor 1 would then be a one-use device. However, where it is desired that the tag 2 and sensor 1 may be re-used, the tag can be reset one or more times by the tag-programmer 6.

Where the system is to be used for transporting sensitive equipment, the container 3 may be pressurized to cushion the equipment. The pressure sensor 1 may then be used, as before, to sense if the seal is broken, in this case, the tag being responsive to a decrease of pressure, below a preset pressure threshold.

In a modification of this system, exposure of the equipment to rough handling can be monitored. Rough handling will result in compression of the container 3 and the resulting pressure increase will be sensed. If an upper threshold is exceeded the data transmitted by tag 2 will be modified. The data may, for example, be 014328 when the seal has been broken, 114328 when the pressure is normal or 214328 when the pressure is high indicating a severe bump during handling. This data may revert to its original state or may be changed permanently depending on the application. Where it is desired to detect when the equipment has experienced excessive shock at some stage during its journey or storage the change will be permanent.

A similar arrangement could be used for sensing and/or recording the crossing of a maximum or minimum temperature threshold using a temperature sensor instead of a pressure sensor. Such an arrangement could be used in the case of storing and/or transporting transplant organs.

Figure 3 of the drawings illustrates a yet further embodiment of the invention in which tag 2 comprises two transponders 20,20' sharing a common antenna 21. In this embodiment, sensor 1 operates as a switch which connects antenna 21 to one or another of the transponders in dependence on the output state of the sensor. The two transponders have respective memories 27,27' storing different identification codes. Accordingly, the retransmitted r.f. frequency will be modulated in accordance with one or the other of the identification codes thereby indicating the current output state of the sensor.

It will be appreciated that if the sensor has more than two output states, the tag may include a corresponding number of transponders. Furthermore, each transponder could have its own antenna, the sensor 1 being used to switch between the antennas according to the sensor's output state.

Where a number of containers 3, each with a tag 2 and a sensor 1, are present in close proximity there may be a risk of interference due to all the tags responding to the transceiver 5 simultaneously. The possibility of this occurring can be reduced by using tags programmed not to respond to interrogation unless, for example, the predetermined physical stimulus had exceeded a certain threshold. If the sensor 1 is a pressure sensor this might occur if the pressure had changed during transit or storage because, for example, the container 3 has been opened, or has been subjected to excessive pressure.

In a yet further embodiment of the invention the sensor 1 may incorporate a capacitor which is short circuited and discharged when the sensor 1 is triggered by the crossing of a threshold of the physical stimulus which is being sensed. Once discharged the state of the sensor 1 will remain unchanged. A special signal would then be required to recharge the capacitor.

It will be understood that the transceiver 5 and the tag-programmer 6 may be of known kind, and in the described embodiments they are shown as separate units. For some applications such as where the contents are held in storage, it will be convenient to combine the transceiver 5 and the tag-programmer 6 into one unit.

The concept of placing valuable items in a vacuum sealed container is especially advantageous in the case of banknotes being transported in a security box. In the event of a security alert the bank notes can be destroyed by exposing them to microwaves generated by a microwave source installed in the box. The notes will be destroyed without them catching fire because the container is evacuated.

#### INDUSTRIAL APPLICABILITY

The invention is applicable to security systems for monitoring the contents of packages or containers while they are being stored or transported.

CLAIMS

1. A security system for testing for exposure of the contents of a container to a predetermined physical stimulus, the security system comprising sensor means sensitive to the predetermined physical stimulus, the sensor means being located within the container and having an output state which can be determined from outside the container.

2. A security system as claimed in claim 1, comprising transmission means for transmitting data representative of the output state of the sensor means in response to an interrogation signal.

3. A security system as claimed in claim 2 including a transceiver for generating said interrogation signal and for receiving data transmitted by the transmission means.

4. A security system as claimed in claim 2, wherein the output state of the sensor means is a continuously up-dated value of the predetermined physical stimulus.

5. A security system as claimed in claim 2, wherein the output state of the sensor means is

indicative of whether said predetermined physical stimulus has crossed or has not crossed a predetermined threshold value.

6. A security system as claimed in claim 5, wherein the transmission means is resettable.

7. A security system as claimed in any one of claims 2 to 6, wherein said transmission means is a passive transmission means.

8. A security system as claimed in any one of claims 2 to 7, wherein the transmission means comprises a transponder.

9. A security system as claimed in claim 8, wherein the transponder is a r.f. transponder.

10. A security system as claimed in any one of claims 2 to 8, wherein the transmission means includes data storage means for storing identification data.

11. A security system as claimed in claim 10, wherein the transmission means comprises a first data storage means storing first identification data, and a second data storage means storing second identification

data; and said sensor means causes the transmission means to transmit either the first or the second identification data in dependence on the output state of the sensor means.

12. A security system as claimed in claim 10, wherein the transmission means comprises at least two data storage means each storing respective identification data, and said sensor means causes the transmission of identification data from a respective said data storage means in dependence on the output state of the sensor means.

13. A security system as claimed in any one of claims 1 to 12, wherein the sensor means is sensitive to a predetermined physical stimulus selected from the group consisting of pressure, temperature, light, magnetic flux and humidity.

14. A method of testing for exposure of the contents of a container to a predetermined physical stimulus, comprising the steps of providing within the container sensor means sensitive to said predetermined physical stimulus, and determining an output state of the sensor means from outside the container.



15. A security container comprising sensor means which is located inside the container and is sensitive to a predetermined physical stimulus, wherein the sensor means has an output state which can be determined from outside the container and is indicative of exposure of the contents of the container to the predetermined physical stimulus.

16. A security container as claimed in claim 15, wherein said sensor means is sensitive to pressure and has an output state indicative of exposure of the contents of the container to ambient pressure outside the container.

1/2

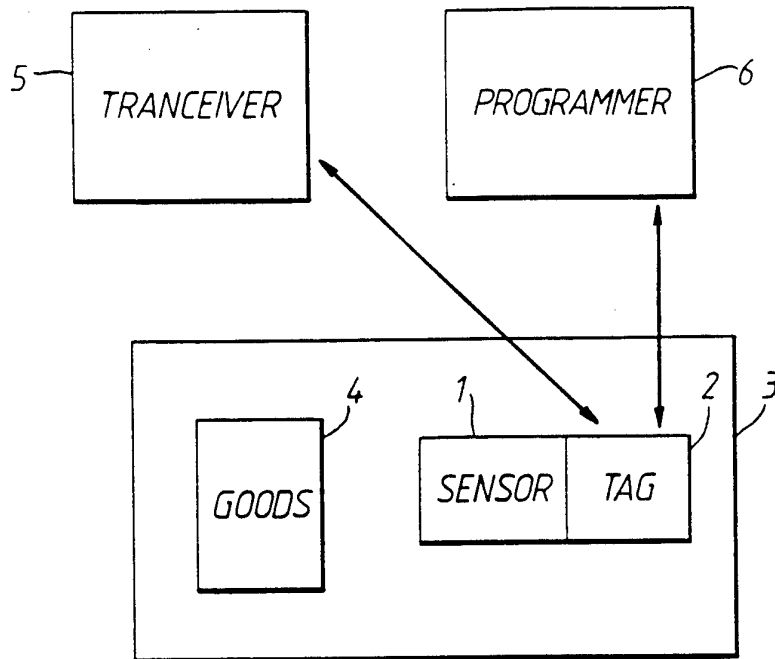

Fig.1

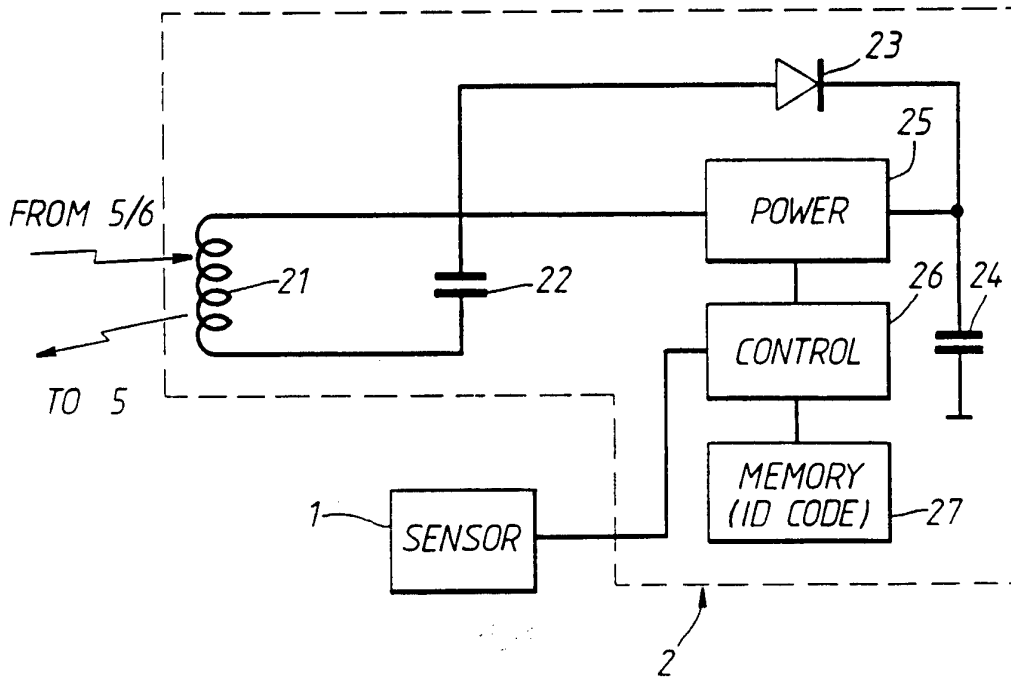

Fig.2

2/2

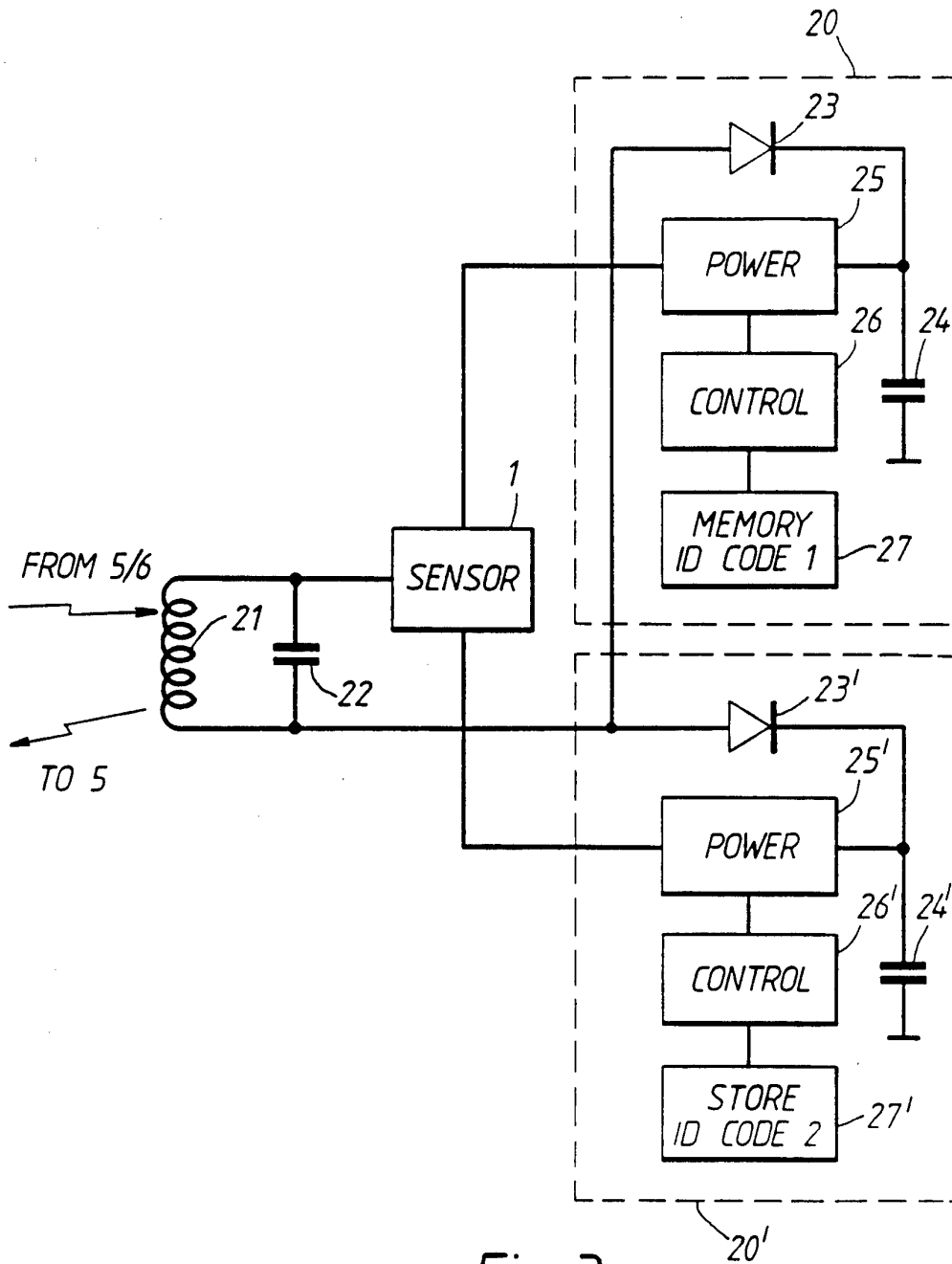

Fig. 3

**INTERNATIONAL SEARCH REPORT**

International Application No  
PCT/GB 94/00992

<b>A. CLASSIFICATION OF SUBJECT MATTER</b> IPC 5 G01D5/48		
According to International Patent Classification (IPC) or to both national classification and IPC:		
<b>B. FIELDS SEARCHED</b>		
Minimum documentation searched (classification system followed by classification symbols) IPC 5 G01D		
Documentation searched other than minimum documentation to the extent that such documents are included in the fields searched		
Electronic data base consulted during the international search (name of data base and, where practical, search terms used)		
<b>C. DOCUMENTS CONSIDERED TO BE RELEVANT</b>		
Category *	Citation of document, with indication, where appropriate, of the relevant passages	Relevant to claim No.
X	GB,A,2 210 536 (THE PLESSEY COMPANY PLC) 7 June 1989 see page 3, line 20 - page 5, line 5; figures 1,2	1-6,8, 10,14,15
Y	---	7,9,13, 16
Y	PATENT ABSTRACTS OF JAPAN vol. 11, no. 236 (P-601) 4 August 1987 & JP,A,62 049 279 (TOSHIBA CORP) 3 March 1987 see abstract	7
Y	WO,A,91 00985 (G. MANNER) 24 January 1991 see page 1, line 18 - line 21 see page 7, line 15 - line 17 align="center">---	9,13,16
	-/--	
<input checked="" type="checkbox"/> Further documents are listed in the continuation of box C.		
<input checked="" type="checkbox"/> Patent family members are listed in annex.		
* Special categories of cited documents :		
"A" document defining the general state of the art which is not considered to be of particular relevance "E" earlier document but published on or after the international filing date "I" document which may throw doubts on priority claim(s) or which is cited to establish the publication date of another citation or other special reason (as specified) "O" document referring to an oral disclosure, use, exhibition or other means "P" document published prior to the international filing date but later than the priority date claimed	"I" later document published after the international filing date or priority date and not in conflict with the application but cited to understand the principle or theory underlying the invention "X" document of particular relevance; the claimed invention cannot be considered novel or cannot be considered to involve an inventive step when the document is taken alone "Y" document of particular relevance; the claimed invention cannot be considered to involve an inventive step when the document is combined with one or more other such documents, such combination being obvious to a person skilled in the art. "&" document member of the same patent family	
Date of the actual completion of the international search  22 July 1994	Date of mailing of the international search report  25.08.94	
Name and mailing address of the ISA European Patent Office, P.B. 5818 Patentlaan 2 NL - 2280 HV Rijswijk Tel. ( + 31-70) 340-2040, Tx. 31 651 epo nl, Fax: ( + 31-70) 340-3016	Authorized officer  Lut, K	

INTERNATIONAL SEARCH REPORT

International Application No.

PCT/GD 94/00992

C.(Continuation) DOCUMENTS CONSIDERED TO BE RELEVANT		
Category °	Citation of document, with indication, where appropriate, of the relevant passages	Relevant to claim No.
A	US,A,4 646 066 (BAUGHMAN ET AL.) 24 February 1987 see column 11, line 3 -----	13

1

# INTERNATIONAL SEARCH REPORT

Information on patent family members

International Application No

PCT/GB 94/00992

Patent document cited in search report	Publication date	Patent family member(s)	Publication date
GB-A-2210536	07-06-89	NONE	
WO-A-9100985	24-01-91	DE-A- 3922556	17-01-91
US-A-4646066	24-02-87	EP-A- 0276335	03-08-88