

[54] **APPARATUS FOR THE UNDERWATER MASSAGE TREATMENT OF A PATIENT**

[76] Inventor: **Kurt Gabmeier, Andreas**  
Hoferstrasse 2-4/2/3/10, A-1210  
Vienna, Austria

[22] Filed: **Apr. 15, 1974**

[21] Appl. No.: **460,683**

[30] **Foreign Application Priority Data**

Apr. 17, 1973 Austria ..... 3421/73

[52] U.S. Cl. .... **128/66**

[51] Int. Cl. .... **A61h 9/00**

[58] Field of Search ..... 128/66, 366, 373; 4/178,  
4/180

[56] **References Cited**

**UNITED STATES PATENTS**

3,455,299 7/1969 Gerow ..... 128/66  
3,579,659 5/1971 Baumann ..... 4/180

3,636,944 1/1972 Bryant ..... 128/66 X

*Primary Examiner*—Lawrence W. Trapp  
*Attorney, Agent, or Firm*—Kurt Kelman

[57] **ABSTRACT**

A patient is supported supine in a bath tub on a flexible, wide-meshed support mounted on a carrier frame. A plurality of nozzles for producing jets of liquid are spaced from each other and below the support so that the liquid jets may be impinged upon the patient through openings in the support. Flexible connecting means suspend the nozzles from the support so that the carrier frame, support and nozzles constitute an immersible unit for free movement into and out of the bath tub. Flexible hoses connect the nozzles to a pump stationarily mounted outside the bath tub for delivering bath liquid thereto and to produce the jets of liquid, the hoses being so arranged as to permit the free movement of the immersible unit.

**9 Claims, 12 Drawing Figures**

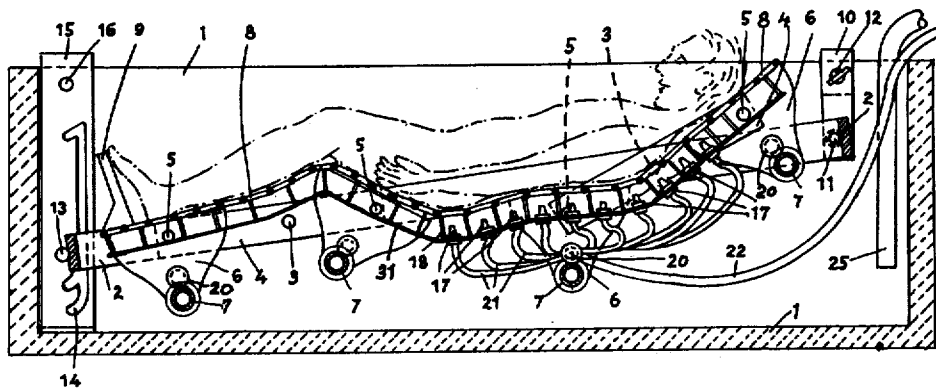

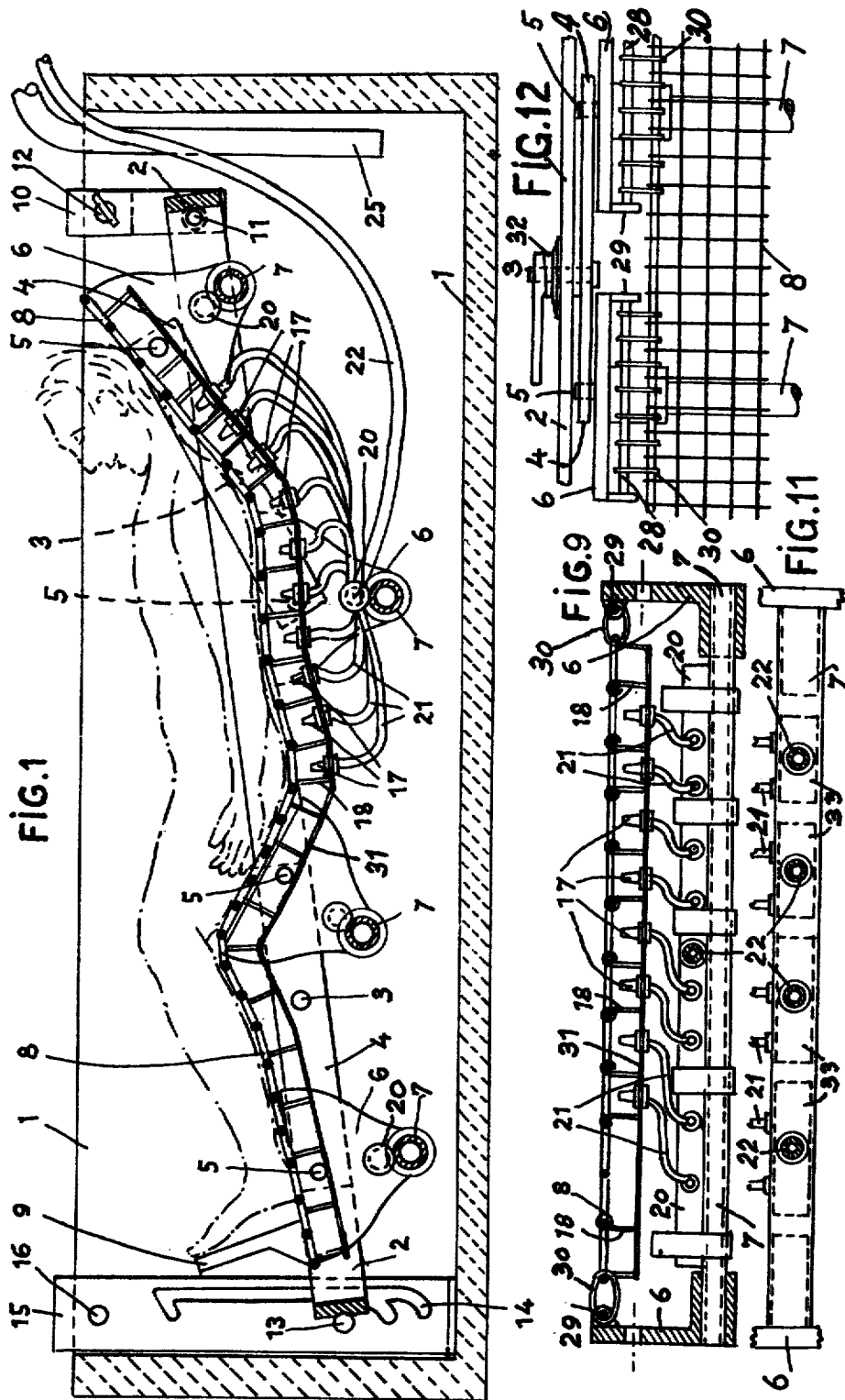

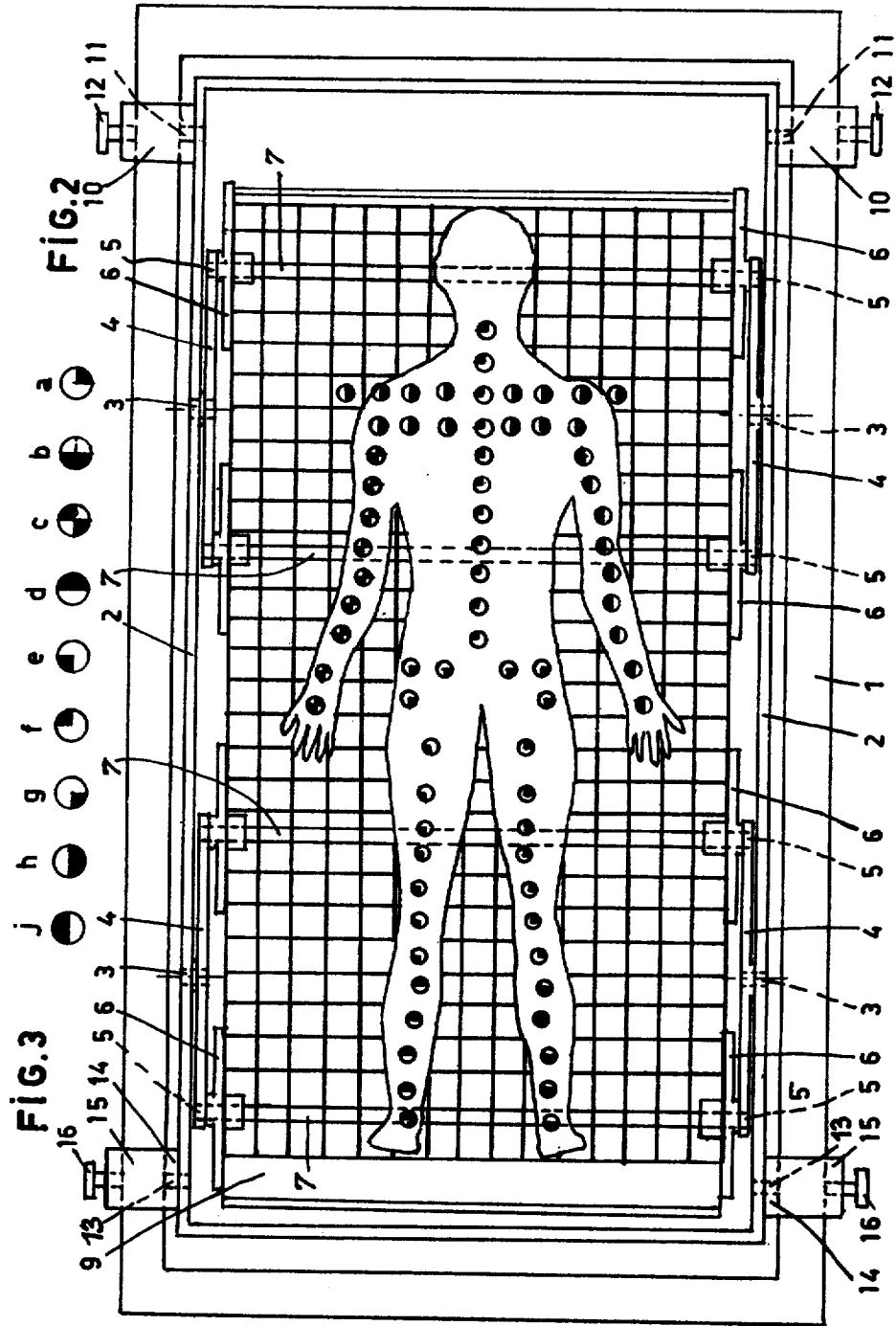

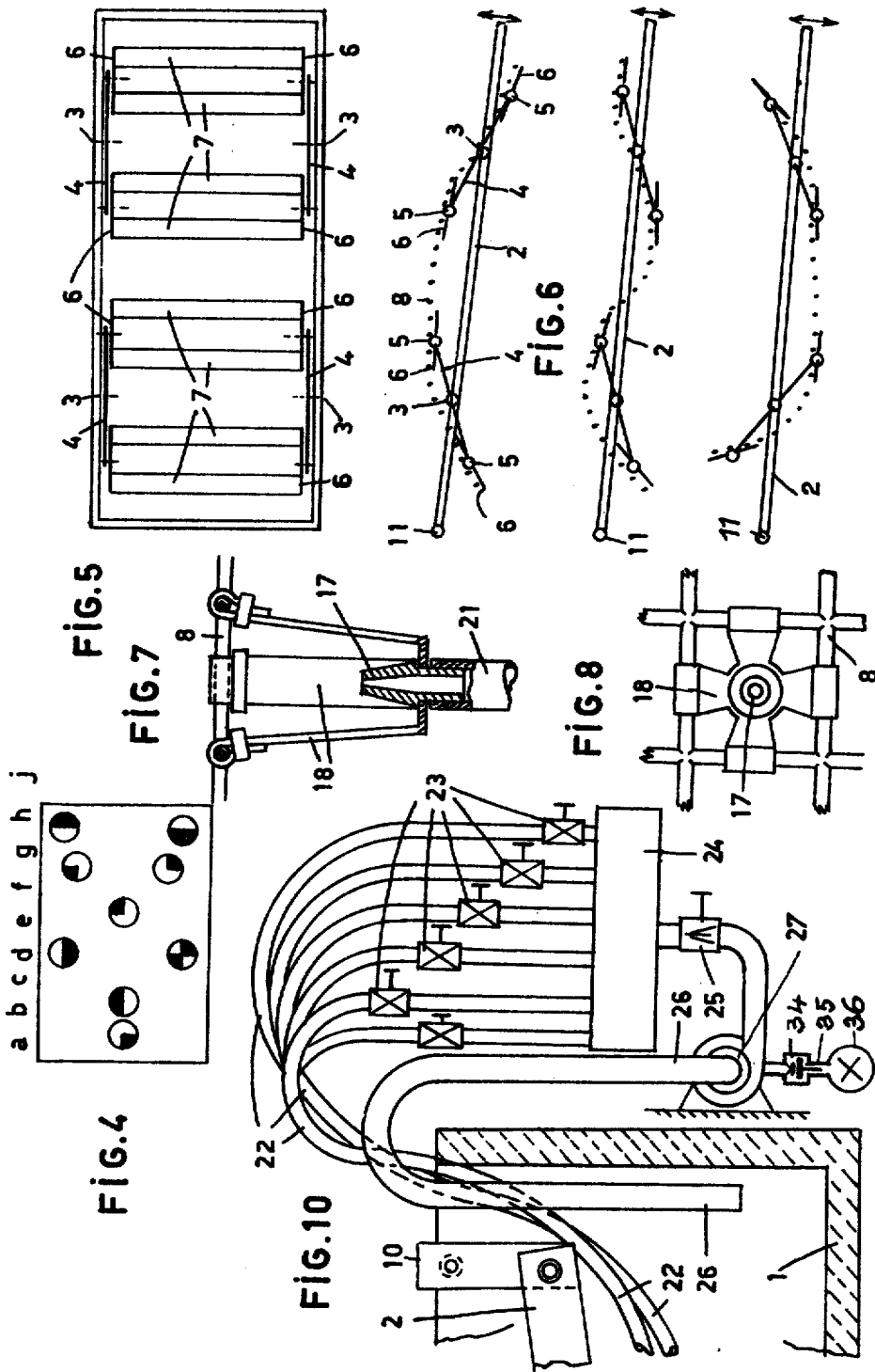

## APPARATUS FOR THE UNDERWATER MASSAGE TREATMENT OF A PATIENT

The present invention relates to improvements in an apparatus for a massage treatment of a patient immersed in bath liquid.

In known apparatus of this type, a support for the patient is mounted in a bath tub containing the bath liquid, and a plurality of nozzles for producing jets of liquid are arranged in the bath liquid spaced from each other and below the support, the jets being impinged upon the patient through openings in the support. The nozzles are connected to a pumping means for circulating the bath liquid and control valve means are arranged between the nozzles and the pumping means to control the flow of the liquid to the nozzles.

In one such known apparatus, the support comprises a plate enabling a patient to sit or lie thereon and having a plurality of openings or passages therein corresponding to the number of nozzles, the nozzles being arrayed in a grid whereon the support plate rests and the nozzle array being supported on a system of liquid supply pipes resting on the bottom of the bath tub. The nozzles are arranged in an array of rows without taking into account the anatomic structure of the human body and are connected to rigid pipes so as to point upwardly. The support plate is arranged in the tub near its bottom so that an ill patient may have difficulty immersing in the bath liquid, particularly when his ability to move is limited. Since the nozzles are fixedly arranged, they cannot be oriented in respect of the patient. Furthermore, since the patient resting on the support plate necessarily blocks a number of the openings therein, only a point-shaped jet will reach the body of the patient at those locations. Specialists in physical medicine consider this as a bubble bath not suitable for providing an underwater massage treatment.

It has also been proposed to replace the rigid support plate in the bath tub with a hanging mat which is first supported on the upper edges of the tub to permit the patient to be placed on the mat, whereupon the mat is lowered a little into the tub. While the flexible support increases the patient's comfort, this arrangement fails to increase the massage effect because the patient is so far removed from the nozzles at the bottom of the tub as to make massage by water jets impossible, the only effect again being comparable to no more than a bubble bath. Since no apparatus is known to produce an effective underwater massage, the usual procedure is the manual massage of a patient in a bath tub with a single jet handled by a trained physical therapist. Of course, the effectiveness of this treatment depends entirely on the skill of the therapist. For instance, the therapist can sometimes only estimate the distance of the manually held nozzle from the body of the patient immersed in a liquid, for instance if the bath liquid is an opaque iodine or sulfur bath. Furthermore, the jet massage can proceed only from point to point so that the total treatment time for a certain part of the body, say an arm or a leg, is actually reduced to a fraction thereof since only one point at a time is actually treated. Other important treatment factors which include entirely on the individual therapist include the distance of the nozzle from each treated body point, which determines the power of the massage, and the speed with which the nozzle is moved along the body. Control of all these factors is often made particularly difficult because the therapist must work with a mask

to protect him or her from noxious vapors emanating from iodine for sulfur baths, for instance. Even with the use of protective masks, therapists often get sick.

It is the primary object of this invention to overcome the disadvantages of known bubble bath apparatus or manual underwater massage and to enable a patient to be placed in a relaxed position on a flexible support outside the bath tub where he may be properly oriented in respect of the jet nozzles, whereupon the fully prepared patient maybe immersed with the nozzles in the bath liquid for the desired underwater massage.

The above and other objects are accomplished in accordance with the invention with a carrier frame freely movable into and out of the bath tub and a flexible, wide-meshed support for the patient mounted on the carrier frame. A plurality of nozzles for producing jets of liquid are spaced from each other and below the support, the jets being impinged upon the patient through openings in the support. Flexible connecting means suspend the nozzles from the support so that the carrier frame, support and nozzles constitute an immersible unit for free movement into and out of the bath tub. A pumping means circulates the bath liquid from the bath tub to the nozzles, the pumping means being stationarily mounted outside the bath tub and flexible hoses connect respective ones of the nozzles to the pumping means for delivering the bath liquid thereto and to produce the jets of liquid. The flexible hoses are arranged to permit the free movement of the immersible unit and control valves are arranged between the nozzles and the pumping means to control the flow of the liquid to the nozzles.

According to one preferred feature of the present invention, groups of the nozzles are arranged for the massage treatment of separate body parts of the patient to be treated by said groups, a distributing main for each group being connected to the control valve and pumping means, and a corresponding group of branch hoses connecting each main to a respective group of nozzles. In this way, the jet pressure for each group may be regulated separately so that a different massage may be applied to separate body parts, such as one of the arms and/or thighs, while all parts are massaged simultaneously.

To enable the patient to be fully relaxed on the flexible support so that each part of his body, such as the head, the torso, the thighs and the lower leg, may rest naturally, the flexible support is sub-divided into a plurality of elongated portions forming an integral support surface for the patient. Each elongated portion corresponds to a body part of the patient for the support thereof, and the carrier frame comprises a pair of elongated beams. A plurality of pairs of carrier elements are pivoted to a respective ones of the carrier frame beams and each pair of carrier elements mounts a respective one of the elongated beams. A plurality of pairs of carrier elements are pivoted to a respective ones of the carrier frame beams and each pair of carrier elements mounts a respective one of the elongated support portions for angular adjustment of the support portions in respect of each other.

The above and other objects, advantages and features of the present invention will be more fully understood from the following detailed description of certain now preferred embodiments thereof, taken in conjunction with the accompanying drawing wherein

FIG. 1 is a vertical section of an embodiment of the apparatus showing a patient (in chain-dotted lines) in position for treatment;

FIG. 2 is a top plan view of the apparatus of FIG. 1;

FIGS. 3 and 4 schematically indicate the valve positions for the various groups of nozzles;

FIG. 5 is a top plan view illustrating the carrier frame and its carrier elements and hangers for the flexible support on which the patient rests;

FIG. 6 shows three possible adjustments of the support;

FIG. 7 is a side elevational view, partly in section, of means for suspending the nozzles;

FIG. 8 is a top plan view of FIG. 7;

FIG. 9 is an end view, partly in section, of one nozzle group associated with a hanger for the support;

FIG. 10 schematically illustrates the pumping and valve means, with the flexible hoses for connection to the nozzles;

FIG. 11 is a top plan view of a modified cross bar for a hanger; and

FIG. 12 is a top plan view of one embodiment of attachment means between the hangers and the flexible support.

Referring now to the drawing and first to FIGS. 1 and 2, there is shown a bath tub 1 suitably dimensioned to accommodate a patient in substantially prone position. The bath tub may contain any type of desired bath liquid, such as an iodine or sulfur bath, and carrier frame 2 is freely movable into and out of the bath tub in a manner to be described hereinafter, the carrier frame being made of a material resistive to corrosion by the bath liquid.

As best shown in FIGS. 2 and 5, carrier frame 2 comprises a pair of elongated beams and a plurality of pairs of carrier elements 4 pivoted at 3 to a respective one of the carrier frame beams, two such pairs of carrier elements being shown in the illustrated embodiment. The carrier elements are levers pivotal in substantially vertical planes extending parallel to the elongated carrier frame beams inside the carrier frame, pivots 3 extending perpendicularly to the vertical planes and mounting the levers on the elongated beams intermediate their ends. In a preferred embodiment, the arms of levers 4 are of unequal lengths.

Hangers 6 are freely pivotally mounted on each of the lever ends for swinging about their pivots 5 in substantially vertical planes parallel to, and inwardly spaced from, the planes wherein levers 4 are pivotal. Cross bars 7 interconnect respective pairs of the hangers for common pendulum movement of each pair of hangers, the length of the cross bars corresponding to the width of flexible, wide-meshed support 8 for the patient. The flexible support is sub-divided into a plurality of elongated portions forming an integral support surface for the patient, each elongated support portion corresponding to a body part of the patient for support thereof. The longitudinal edges of the support are detachably mounted on hangers 6 for longitudinal movement of the support edges in respect of the hangers, and the hangers keep the flexible support under transverse tension when the longitudinal support edges are mounted on the hangers.

FIG. 12 illustrates a specific embodiment of means for mounting the longitudinal edges of support 8 on hangers 6, this means comprising bearings 29 affixed to the upper edges of the hangers and guide rods 28

mounted in the bearings and extending along the longitudinal support edges. A plurality of connecting members, such as rings 30, are mounted on guide means 28 for free movement therealong, these rings engaging the reinforced longitudinal edges of flexible support 8 for detachably mounting the edges on the hangers under transverse tension, as shown in the end view of FIG. 9.

The flexible, wide-meshed support is constituted essentially by a net capable of supporting a patient and made, for instance, of polyester cords or a polyester sheet having a multiplicity of holes. Any other material resistive to the bath liquid may be used for the flexible support.

For comfort, foot rest 9 is mounted on one of the hangers adjacent one end of the carrier frame (see FIG. 3).

A pair of connecting plates 10 are affixed to the elongated carrier frame beams at one of their ends, for instance by means of illustrated pivot pin 11. The upper ends of the connecting plates may simply be bent over for suspension on the upper edge of the bath tub or, as shown in the illustrated embodiment, the upper edges of the connecting plates may have a bore receiving a clamping screw 12 for detachably mounting one end of the carrier frame in the bath tub. This carrier frame end supports the head part of the patient's body and its height is adjusted suitably to hold the head above the bath liquid. The cross beam of carrier frame 2 adjacent the foot part of the patient has a pair of laterally projecting support pins 13 for adjustable engagement in slots defined by a pair of support plates 14. The lower ends of the support plates stand freely on the bottom of the bath tub while their upper ends are bent over to engage the upper rim of the tub, being detachably affixed thereto by clamping screws 16. A series of vertically spaced slots in the support plates enable the foot end of the carrier frame to be suitably adjusted in height so as to determine a desired degree of inclination of the carrier frame.

It is, of course, possible to provide a winch and cable at the ends of the carrier frame for lowering and lifting it.

A plurality of nozzles 17 for producing jets of liquid are spaced from each other and below the support, the jets being impinged upon the patient through the mesh openings in support 8. As particularly shown in FIGS. 7 and 8, the flexible connecting means for suspending the nozzles from the support comprises a multi-armed carrier 18, such as the illustrated cruciform carrier holding each nozzle and attached to the cords of net 8. In this manner, each nozzle will follow any movement of the net support without a change in the spacing between the nozzle and the support.

Another flexible connecting means for suspending nozzles 17 from support 8 is shown in FIG. 9 wherein flexible carrier mat 31 defining a multiplicity of openings replaceably receives respective ones of nozzles 17 in the openings in a selected array. The carrier mat is suspended from flexible support 8 by means of carrier members 18 at a distance therefrom and consists of a corrosion-resistant synthetic resin. The openings are distributed over the entire mat and are designed to receive and hold the nozzles in the selected array. Each nozzle comprises two parts which are screwed together on assembly, the edges of each mat opening being clamped between the two nozzle parts when they are assembled. The carrier mat automatically moves with

the flexible support without changing its distance therefrom.

The plan view of FIG. 2 illustrates one selected array of nozzles by way of example, the nozzles being arranged in groups for the massage treatment of separate body parts of the patient to be treated by each group of nozzles. As indicated in the schematic showing of FIG. 3, group *a* of nozzles 17 serves to massage the spine, group *b* for the shoulders, group *c* for the left arm, and group *d* for the right arm. Groups *e*, *f*, *g*, *h* and *j* are used, respectively, for the massage of the hip, the left and right thighs, and the left and right lower legs of the patient.

As shown in FIGS. 9 and 11, each group of nozzles has a main connected to the control valve and pumping means, and a corresponding group of branch hoses connecting the main to the nozzles of the group. In the embodiment of FIG. 9, main 20 is affixed to cross bar 7, with branch hoses 21 leading from the main to the nozzles. In the embodiment of FIG. 11, the cross bar is tubular and sub-divided into liquid distributing chambers 33, branch hoses 21 leading from each chamber to the nozzles. A main hose 22 connects each main 20 or 33 to a respective control valve 23 (see FIG. 10). Pumping means 27 for circulating the bath liquid from the bath tub to the nozzles is stationarily mounted outside the tub and comprises an intake chamber and an output connected to each control valve 23 for a respective group of nozzles to control the flow of liquid thereto. Pressure reducing valve 25 is mounted in the connecting conduit between the output of the pump and the control valves to adjust the liquid pressure to that desired for the massage treatment, the liquid being delivered from the pressure reducing valve to pressure chamber 24 whence it flows to control valves 23. A suction intake pipe 26 extends from the bath tub into the intake chamber of the pumping means for delivering bath liquid thereto. The pump may be a radial flow pump.

In the embodiment shown in FIG. 10, a source of gas 36, for instance an oxygen source, is connected by a second intake conduit 35 to the intake chamber of a pump and a closable check valve 34 is mounted in conduit 35. If desired, conduit 35 may open simply to the surrounding atmosphere to deliver air into the intake chamber of the pump when valve 34 is opened so as to produce a gas and bath liquid mixture in the intake chamber for delivery to the massage nozzles 17.

The massage treatment with the above-described apparatus proceeds as follows:

Carrier frame is vertically adjusted to its uppermost position so that the patient may lie down on the flexible support net outside the bath liquid. The levers 4 and hangers 6 are now pivoted until flexible support 8 has assumed a position most comfortable for the patient, such as indicated in FIG. 1, so that the patient reclines fully relaxed on the support, whereupon pivot pins 5 are affixed to carrier frame 2 so that the flexible support remains in its adjusted position. It is also possible, as shown in FIG. 12, to provide a locking device 32 for locking lever 4 in the adjusted position.

After the patient has thus been placed on flexible support 8 and the same has been suitably adjusted, carrier frame 2, support 8 and nozzles 17 are immersed as a unit into the bath liquid to the extent required or desired for the treatment, at least those parts of the body of the patient which are to be massaged being sub-

merged in the bath liquid. Control valves 23 controlling the flow of liquid to the respective groups of nozzles 17 are now operated to circulate the bath liquid from the tub to the selected groups of nozzles, the liquid pressure being suitable adjusted by valve 25 to produce jets of liquid for the massage of the selected points with the same intensity and thus produce an absolutely even and controlled massage. It is, of course, also possible to open all valves 23 so as to produce a strong bubble bath of considerably greater intensity than those produced by apparatus heretofore available. If the bath liquid contains iodine or sulfure, it will be useful for the patient to wear a gas mask to prevent him from inhaling noxious fumes.

Clearly, the adjustability of the flexible support is considerable, some positions being indicated on FIG. 6.

What is claimed is:

1. An apparatus for massage treatment of a patient immersed in bath liquid, comprising the combination of
  1. a bath tub containing the bath liquid,
  2. a carrier frame freely movable into and out of the bath tub,
  3. a flexible, wide-meshed support for the patient mounted on the carrier frame,
  4. a plurality of nozzles for producing jets of liquid spaced from each other and below the support,
    - a. the jets being impinged upon the patient through openings in the support,
  5. flexible connecting means for suspending the nozzles from the support,
    - a. the carrier frame, support and nozzles constituting an immersible unit for free movement into and out of the bath tub,
  6. a pumping means for circulating the bath liquid from the bath tub to the nozzles, the pumping means being stationarily mounted outside the bath tub,
  7. flexible hoses connecting respective ones of the nozzles to the pumping means for delivering the bath liquid thereto and producing the jets of liquid, the flexible hoses being arranged to permit the free movement of the immersible unit, and
  8. control valve means arranged between the nozzles and the pumping means to control the flow of the liquid to the nozzles.
2. The apparatus of claim 1, wherein groups of the nozzles are arranged for the massage treatment of separate body parts of the patient to be treated by said groups, and further comprising a main for each of said groups, the main being connected to the control valve and pumping means, and a corresponding group of branch hoses connecting the main to the nozzles of the group.
3. The apparatus of claim 1, wherein the flexible support is sub-divided into a plurality of elongated portions forming an integral support surface for the patient, each elongated support portion corresponding to a body part of the patient for the support thereof, and the carrier frame comprises a pair of elongated beams and further comprising a plurality of pairs of carrier elements pivoted to a respective one of the carrier frame beams and each pair of carrier elements mounting a respective one of the elongated support portions for angular adjustment of the support portions in respect of each other.
4. The apparatus of claim 3, wherein the carrier elements are levers pivotal in substantially vertical planes

extending parallel to the elongated carrier frame beams inside the carrier frame, pivots extending perpendicularly to the vertical planes and mounting the levers on the elongated beams intermediate their ends, and further comprising hangers freely pivotally mounted on each of the lever ends for swinging in substantially vertical planes parallel to, and inwardly spaced from, the planes wherein the levers are pivotal, cross bars interconnecting respective pairs of the hangers for common pivotal movement of each pair of hangers, the length of the cross bars corresponding to the width of the flexible support, the longitudinal edges of the support being detachably mounted on the hangers for longitudinal movement of the support edges in respect of the hangers and the hangers keeping the flexible support under transverse tension when the longitudinal support edges are mounted on the hangers.

5. The apparatus of claim 4, further comprising guide means arranged on the hangers and extending along the longitudinal support edges, and a plurality of connecting members mounted on the guide means for movement therealong, the connecting members detachably mounting the longitudinal support edges on the hangers under transverse tension.

6. The apparatus of claim 4, further comprising an adjustable foot rest mounted on one of the hangers adjacent one end of the carrier frame.

7. The apparatus of claim 1, wherein the flexible support is sub-divided into a plurality of elongated portions forming an integral support surface for the patient, each elongated support portion corresponding to a body part of the patient for the support thereof, the carrier frame comprises a pair of elongated beams, and further comprising a plurality of pairs of levers pivoted to a respective one of the carrier frame beams intermediate their ends for pivoting in substantially vertical planes extending parallel to the elongated carrier frame beams inside the carrier frame, hangers freely pivotally mounted on each of the lever ends for swinging in substantially vertical planes parallel to, and inwardly

spaced from, the planes wherein the levers pivot, tubular cross bars interconnecting respective pairs of the hangers for common pivotal movements of each pair of hangers, the length of the cross bars corresponding to the width of the flexible support, the longitudinal edges of the support being detachably mounted on the hangers for longitudinal movement of the support edges in respect of the hangers and the hangers keeping the flexible support under transverse tension when the longitudinal support edges are mounted on the hangers, pivoting of the levers and hangers angularly adjusting the elongated support portions in respect of each other, and groups of the nozzles being arranged for massage treatment of separate body parts of the patient to be treated by said groups of nozzles, the tubular cross bars being sub-divided into liquid distributing chambers, a main hose connecting the control valve and pumping means to each of the distributing chambers, and branch hoses connecting each distributing chamber to a respective group of nozzles.

8. The apparatus of claim 1, wherein the flexible connecting means for suspending the nozzles from the support comprises a flexible carrier mat defining a multiplicity of openings for replaceably receiving respective ones of the nozzles in a selected array, the carrier mat being suspended from the flexible support at a distance therefrom and being of a corrosion-resistant synthetic resin.

9. The apparatus of claim 1, wherein the pumping means comprises an intake chamber and an output, and further comprising a first intake conduit extending from the bath tub into the intake chamber for delivering bath liquid thereto, a source of a gas, a second intake conduit connecting the gas source to the intake chamber, a closable check valve in the second intake, a gas and bath liquid mixture being produced in the intake chamber upon opening of the check valve, and the output of the pumping means being connected to the control valve means.

\* \* \* \* \*

45

50

55

60

65