



US00D728133S

(12) **United States Design Patent**
Bieling et al.

(10) **Patent No.:** **US D728,133 S**

(45) **Date of Patent:** **** Apr. 28, 2015**

(54) **HEADLIGHT FOR A VEHICLE**

D679,430 S 4/2013 Frenzel et al.
D679,844 S 4/2013 Frenzel et al.
D691,298 S * 10/2013 Binder et al. D26/28

(71) Applicant: **Daimler AG**, Stuttgart (DE)

* cited by examiner

(72) Inventors: **Matthias Bieling**, Gaertringen (DE);
Hans-Dieter Futschik, Gechingen (DE);
Stefan Handt, Stuttgart (DE); **Frank Pfisterer**, Weil der Stadt (DE); **Gorden Wagener**, Gaeufelden (DE)

Primary Examiner — Marcus Jackson
(74) *Attorney, Agent, or Firm* — Crowell & Moring LLP

(73) Assignee: **Daimler AG**, Stuttgart (DE)

(57) **CLAIM**
The ornamental design for a headlight for a vehicle, as shown and described.

(**) Term: **14 Years**

(21) Appl. No.: **29/455,773**

DESCRIPTION

(22) Filed: **May 24, 2013**

This application contains subject matter related to the following co-pending U.S. design patent applications: Application Ser. No. 29/455,774, filed herewith and entitled "Headlight for a Vehicle"; Application Ser. No. 29/446,299, filed Feb. 22, 2013 and entitled "Vehicle, Toy, and/or Replicas Thereof;" and Application Ser. No. 29/446,300, filed Feb. 22, 2013 and entitled "Front Portion of a Vehicle, Toy, and/or Replicas Thereof."

(30) **Foreign Application Priority Data**

Nov. 28, 2012 (DE) 40 2012 005 357

(51) **LOC (10) Cl.** **26-06**

(52) **U.S. Cl.**
USPC **D26/28**

(58) **Field of Classification Search**
USPC D26/28-36; 362/459-468, 475-478,
362/485-487

See application file for complete search history.

FIG. 1 is a right perspective view of a first embodiment of a headlight for a vehicle according to the design;
FIG. 2 is a front view thereof.
FIG. 3 is a right side view thereof; and
FIG. 4 is a top view thereof.
FIG. 5 is a left perspective view of a second embodiment of the headlight for a vehicle thereof, with the headlight for a vehicle from the opposite side of the vehicle being depicted in the first embodiment;
FIG. 6 is a front view thereof.
FIG. 7 is a left side view thereof; and,
FIG. 8 is a top view thereof.

The broken lines are for illustrative purposes only and form no part of the claimed design. Also enclosed is a set of photographs of an embodiment of the design.

(56) **References Cited**

U.S. PATENT DOCUMENTS

D538,956 S	*	3/2007	Ishii	D26/28
D544,614 S	*	6/2007	Markelka	D26/28
D561,358 S	*	2/2008	Tachibana	D26/28
D570,007 S	*	5/2008	Hsu	D26/28
D582,587 S	*	12/2008	Yang	D26/28
D593,232 S	*	5/2009	Koman et al.	D26/28
D635,694 S	*	4/2011	Yang et al.	D26/28
D671,033 S		11/2012	Fetherston et al.		
D671,044 S		11/2012	Fetherston et al.		
D679,429 S		4/2013	Frenzel et al.		

1 Claim, 4 Drawing Sheets

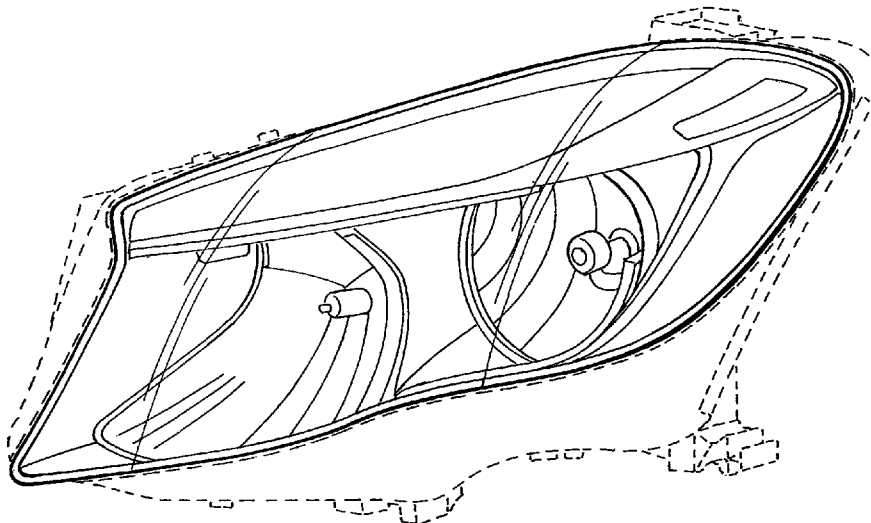

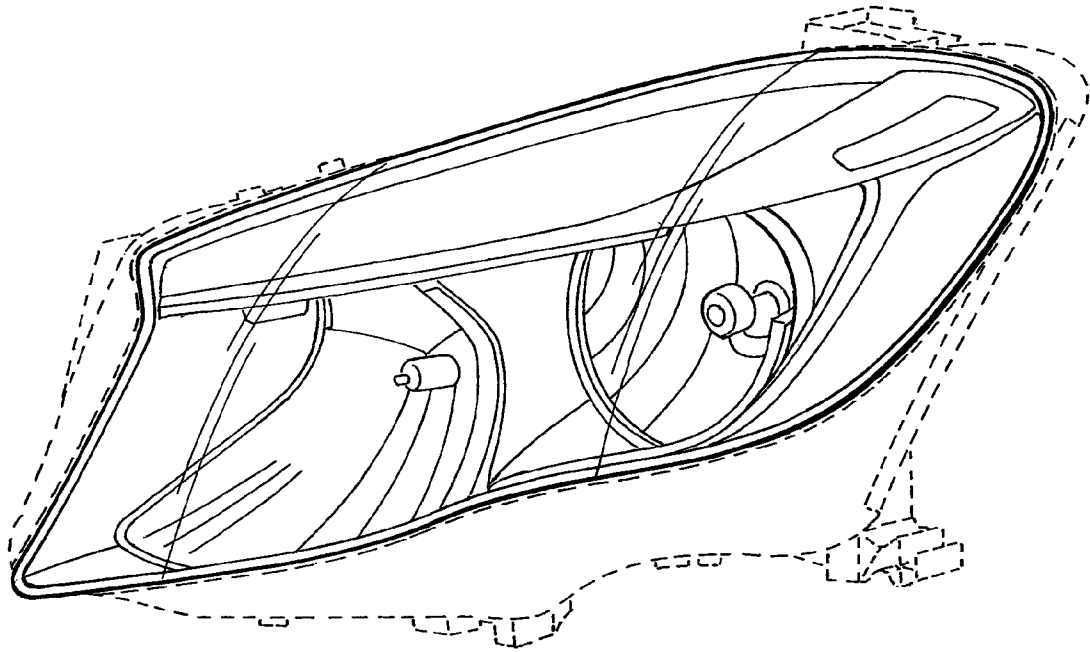

FIG. 1

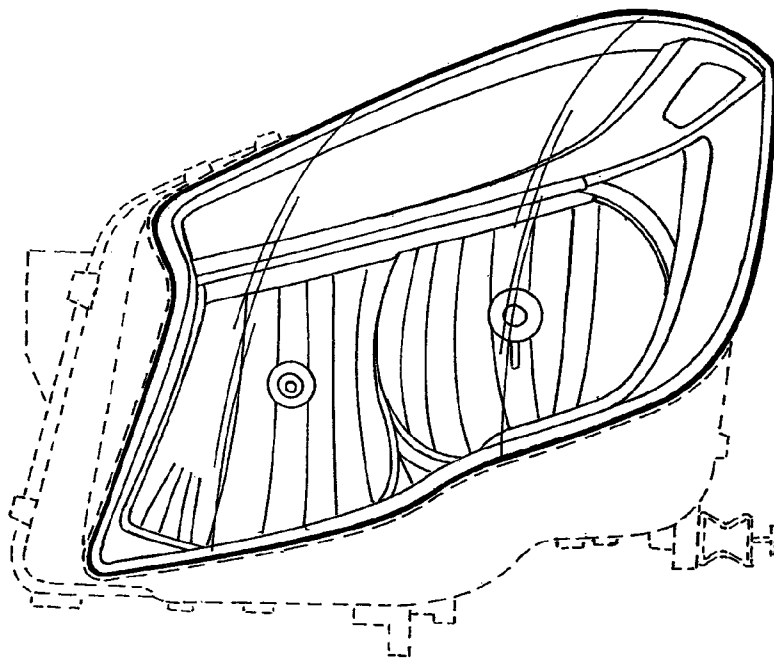

FIG. 2

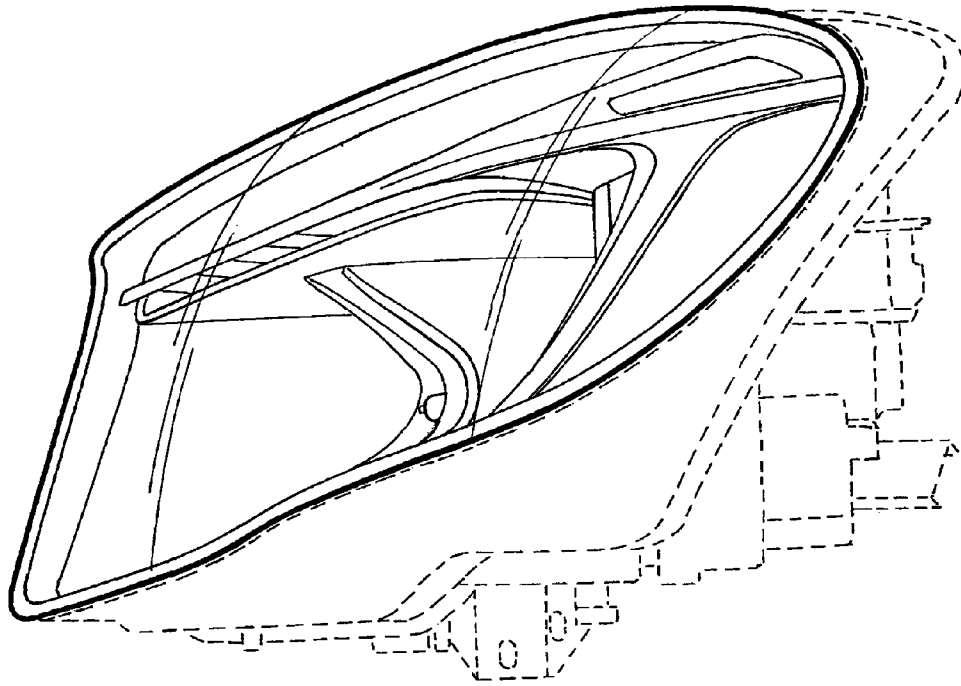

FIG. 3

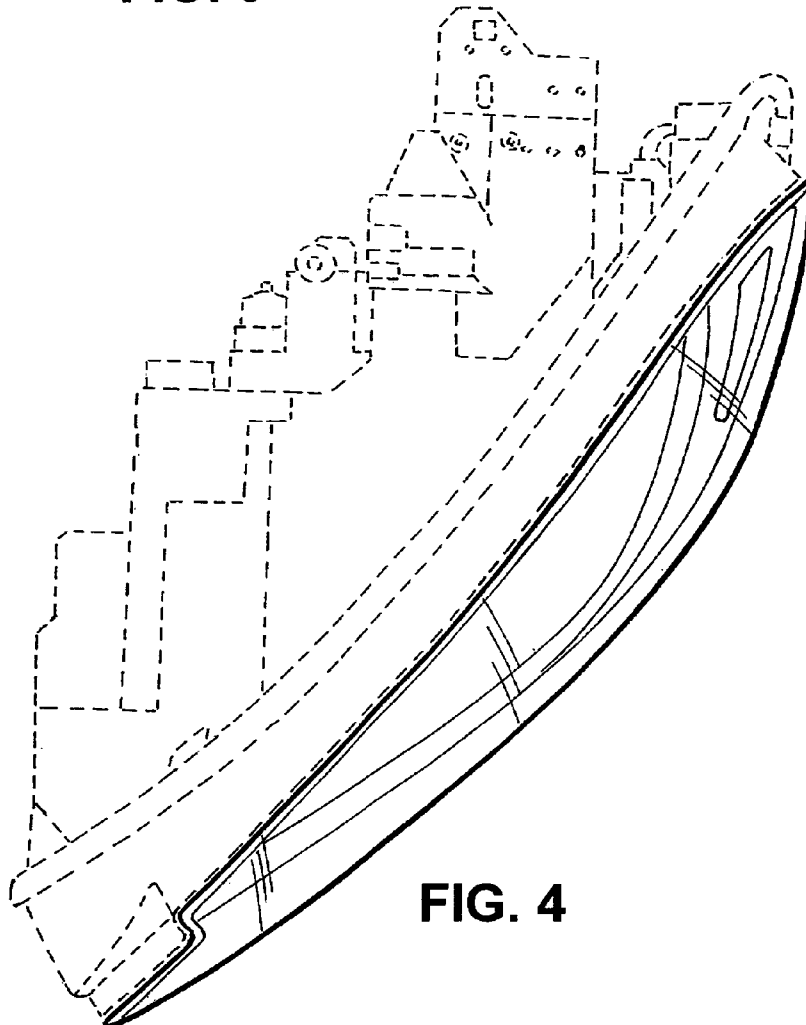

FIG. 4

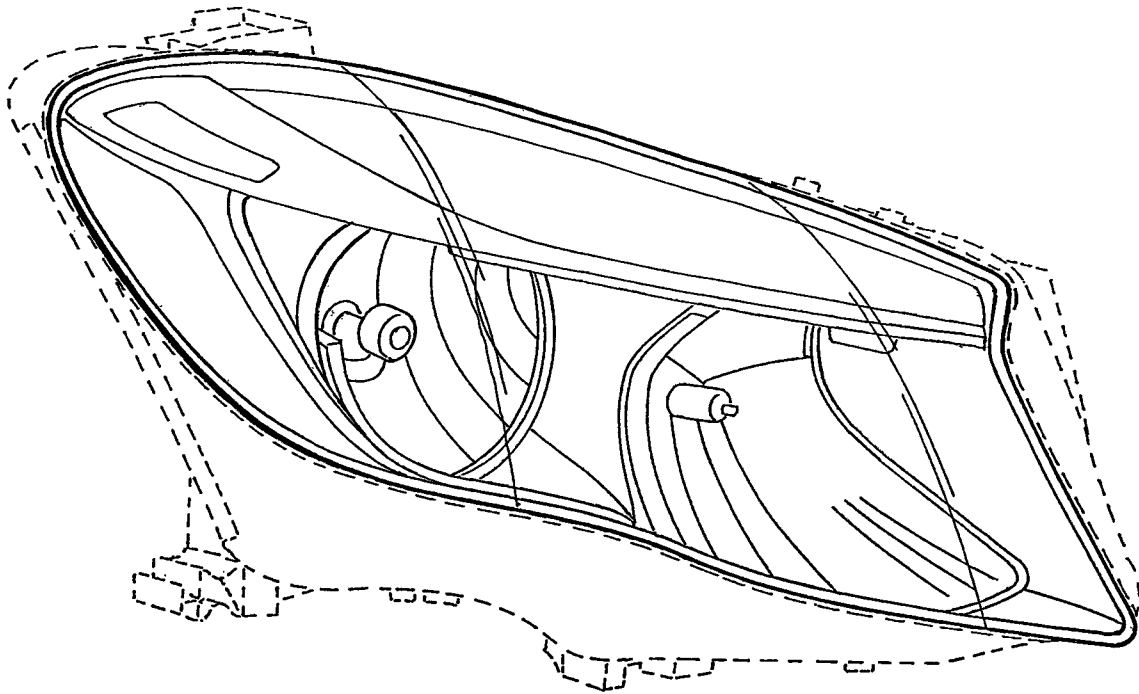

FIG. 5

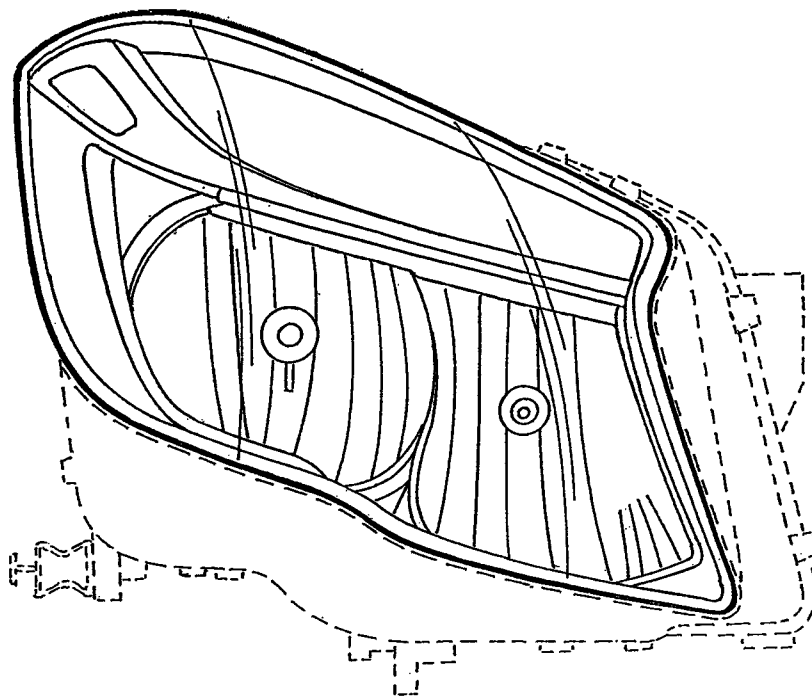

FIG. 6

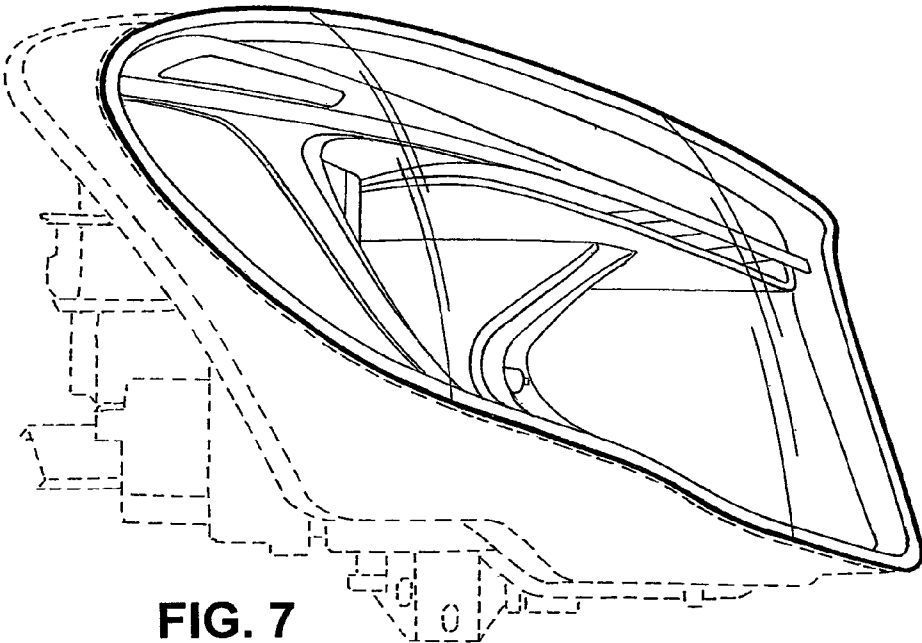

FIG. 7

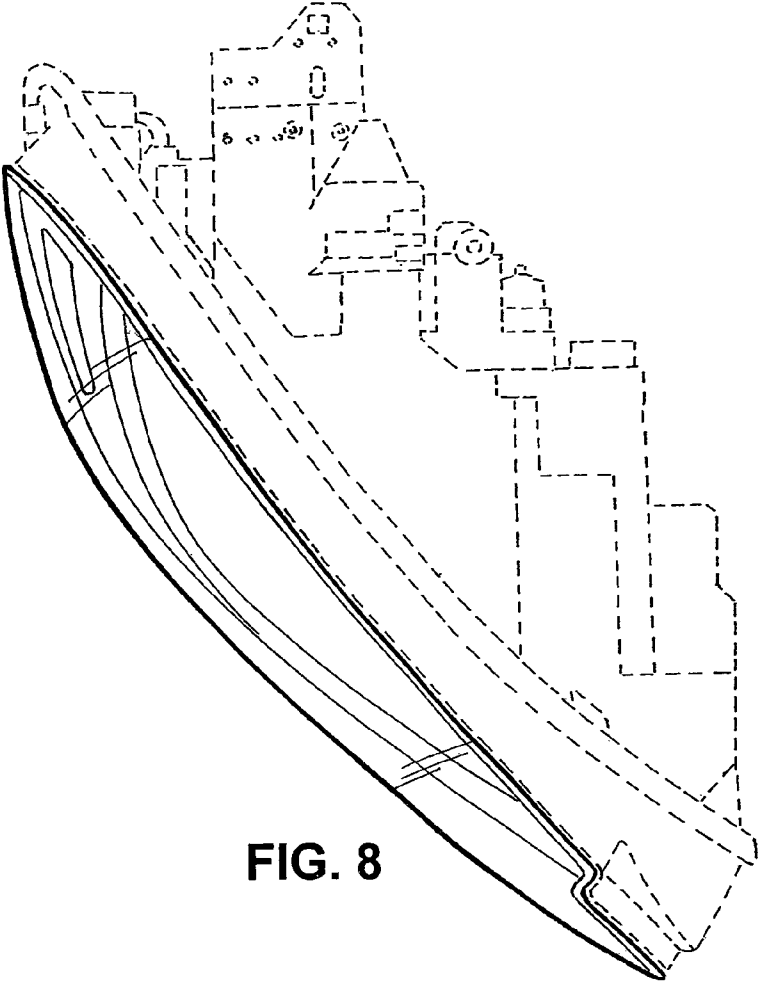

FIG. 8