

H. G. ANTHONY.
 STOOL AND TABLE JACK.
 APPLICATION FILED AUG. 8, 1917.

1,246,837.

Patented Nov. 20, 1917.

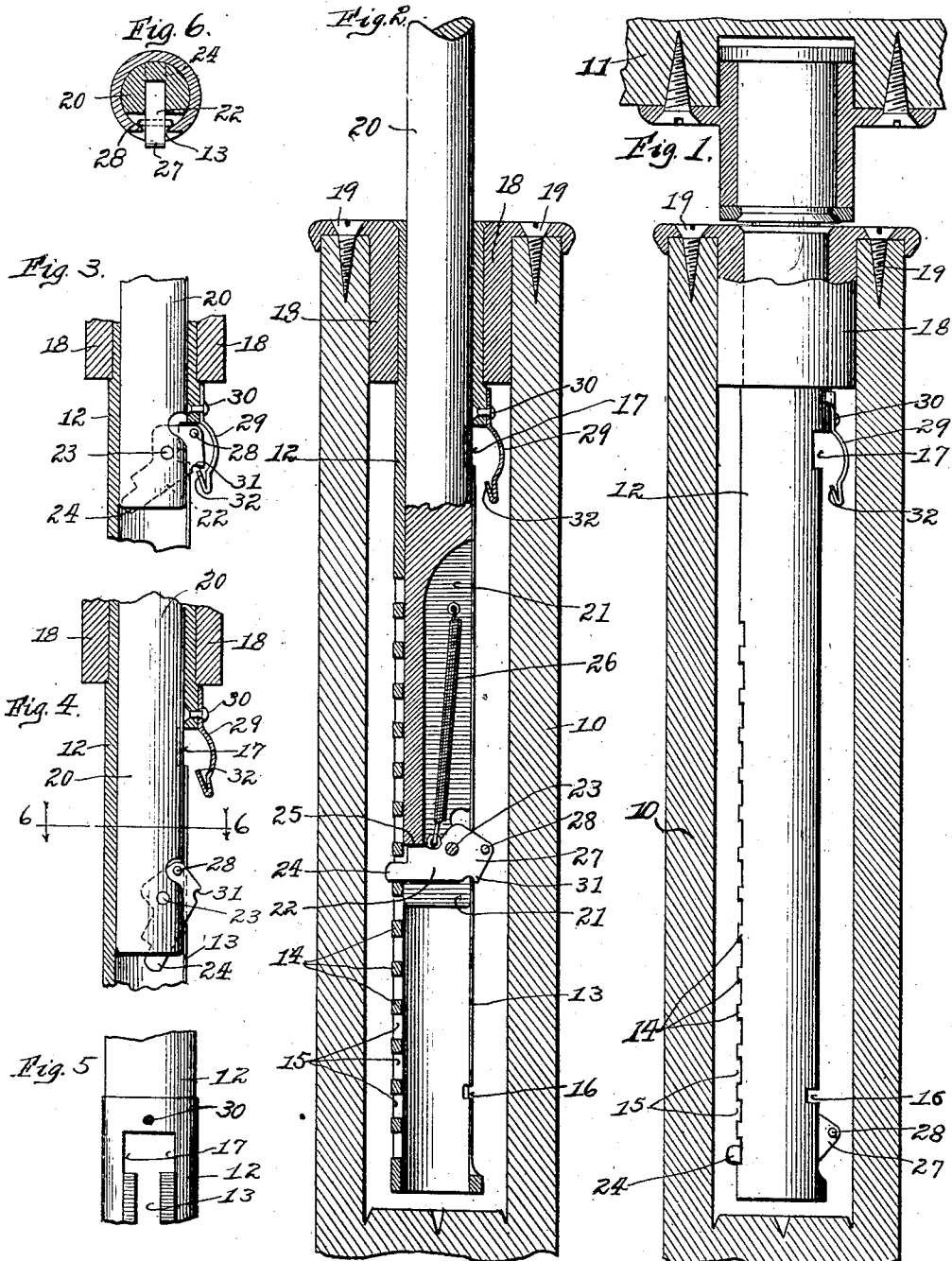

Witness:
 L. B. Cleam

Inventor:
 Harold G. Anthony,
 By *Proven Macken Spruick*
 His Attys.

UNITED STATES PATENT OFFICE.

HAROLD G. ANTHONY, OF CHICAGO, ILLINOIS.

STOOL AND TABLE JACK.

1,246,837.

Specification of Letters Patent. Patented Nov. 20, 1917.

Application filed August 8, 1917. Serial No. 185,032.

To all whom it may concern:

Be it known that I, HAROLD G. ANTHONY, a citizen of the United States, residing at Chicago, in the county of Cook and State of Illinois, have invented certain new and useful Improvements in Stool and Table Jacks, of which the following is a specification.

My invention relates to stool and table jacks, and has for its object the provision of a simple and efficient jack or adjustable support adapted to be incorporated in stool, chair, bench, table, and the like, constructions.

A further object is the provision of a jack or adjustable support as mentioned capable of quick and easy adjustments.

Other objects will appear hereinafter.

An embodiment of my invention is shown in the accompanying drawing, forming a part of this specification, and in which—

Figure 1 is a view of a jack or adjustable support embodying my invention shown as being mounted in the pedestal of a stool, or the like.

Fig. 2 is a similar view showing my improvement in section and with the upper end broken away.

Figs. 3, 4 and 5 are fragmental details of different parts of the construction; and

Fig. 6 is a section taken on line 6—6 of Fig. 4.

My improved jack or adjustable support is particularly adaptable for embodiment in the construction of piano stools, piano benches, tables, chairs, stools, and wherever it is desired to have an adjustable seat, table, or the like.

Referring more particularly to the drawing, I have shown the pedestal 10 of a stool, or the like, and a seat part 11 of such stool with my improved device mounted therein. My improvement consists essentially of two telescoping members, or two members mounted to slide adjacent each other, and one longitudinally of the other. It will be understood that many shapes of these two members may be employed, and I have shown one form as being two cylindrical members telescoped together. The outer member 12 is preferably tubular with a longitudinal slot 13 formed in one side. In the side of the member 12, opposite the slot 13, I provide a plurality of ratchet teeth 14 which are adapted for engagement from the inside of the member 12. In the form shown these teeth comprise portions of the tube 12 be-

tween perforations 15 made therein, but any other form of teeth may be provided as desired. At the lower end of the slot 13 I provide notches 16, and at the upper end of the slot 13 I provide notches 17, the purpose of which will be explained later.

The tubular member 12 may be mounted in the pedestal 10 in any desired manner. I have shown a bushing 18 extending into the hollow part of the pedestal 10 and secured to the latter by means of screws 19. Any form of securing the tubular member 12 in the pedestal 10 may be used as desired.

Slidably mounted in the tubular member 12 is a cylindrical member 20, having a slot 21 formed in its lower end. In said slot is a pawl 22, pivoted as at 23 in said slot 21. The pawl 22 has a point 24 adapted to engage the ratchet teeth 14. The pawl 22 is adapted to swing against a shoulder 25 formed in the member 20 so that when the point 24 engages the teeth 14, the pawl will engage the shoulder 25 and prevent downward movement of the member 20. The pawl 22 and its parts are so formed that it can swing on its pivotal point 23 to let the point 24 pass from one tooth 14 to the next above tooth 14 in the movement of the member 20 upwardly so as to be able to lock the member 20 on any one of the teeth 14 against downward movement. A spring 26 is connected with the pawl 22 and tends to normally press the latter against the shoulder 25.

The pawl 22 is provided with an extension 27 which extends outwardly through the slot 13 of member 12 and prevents rotary movement of the member 20 in the member 12. This part 27 is provided with an enlargement or pin 28 which is adapted to ride on the outside of the member 12 when the point 24 of the pawl is in engagement with the teeth 14.

When the member 20 has reached its upward terminal movement, the end 27 of the pawl rides under a curved spring 29, which is secured as at 30 to the member 12. As soon as the member 20 is moved downwardly from its upward terminal movement, a shoulder 31 on the pawl 22 engages a shoulder 32 on the spring 29 and moves the pawl on its pivotal point 23 so that the pin 28 passes through the notches 17 which swings the point 24 out of engagement with the teeth 14. As soon as the member 20 passes downwardly so that the shoulder 31

disengages the shoulder 32, the pin 28 will engage the inner side of the member 12 adjacent the sides of slot 13 and hold the point 24 of the pawl out of engagement with the teeth 14. When the member 20 has reached its lower terminal of movement, the pin 28 engages the notches 16 in the slot 13 and permits the spring 26 to swing the pawl and move the end 27 out of slot 13 and point 24 into engagement with the teeth 14 again. With this arrangement is it only necessary to raise the member 20 to the desired height where the point 24 will engage a proper tooth 14 and hold said member at such height. If the member 20 has been raised higher than is desired, it is only necessary to raise it on to its upper terminal of movement, where the point 24 will be moved out of engagement with the teeth 14, then lower it to its lower terminal of movement, where the point 24 will again be brought into engagement with the teeth 14, and then again raised to the desired height.

The seat part 11 may be mounted on the upper end of member 20, such as is indicated in Fig. 1, or in any other desired manner. It will also be apparent that various forms of pedestals and members mounted on the top of member 20 may be accommodated by my improvement. Also, that two or more or my jacks or adjustable supports may be fitted in the same construction to work together.

While I have illustrated and described the preferred form of my invention, I do not desire to be limited to the precise details set forth, but desire to avail myself of such variations and changes as come within the scope of the appended claims.

I claim:—

1. In combination, two telescoping members, the outer of said members having ratchet teeth and a slot extending longitudinally thereof; a pawl pivoted in the inner of said members with one end thereof adapted to engage said ratchet teeth and the other end thereof adapted to extend through said slot; a spring catch secured to the outer member at one end of said slot and adapted to engage the end of said pawl extending through said slot and swing said pawl out of engagement with said ratchet teeth; and means on the pawl adapted to engage the inner side of the outer member and hold the pawl out of engagement with the ratchet teeth.

2. In combination, two telescoping members, the outer of said members having

ratchet teeth and a slot extending longitudinally thereof; a pawl pivoted in the inner of said members with one end engaging said slot and the other end adapted to engage said ratchet teeth; a pin in the pawl; a spring connected with the pawl tending to hold the pawl in engagement with the ratchet teeth; and a catch at one end of said slot adapted to engage the pawl and move said pin through said slot into the outer of said members, said pin when in the latter being adapted to engage said outer member at the edges of said slot and hold the pawl out of engagement with the ratchet teeth.

3. In combination, two telescoping members, the outer member having a longitudinal slot in one side and ratchet teeth opposite the slot; a pawl pivoted on the inner member with one end adapted to engage the ratchet teeth and its other end engaging said slot; means on the pawl adapted to engage the inner side of the outer member adjacent said slot and hold the pawl out of engagement with the ratchet teeth.

4. In combination, two telescoping members, the outer member having a longitudinal slot in one side and ratchet teeth in its side opposite said slot; a pawl pivoted on the inner member and having one end adapted to engage the ratchet teeth and limit relative longitudinal movements of the members in one direction; and means on the pawl adapted to engage the inner side of the outer member adjacent said slot and hold the pawl out of engagement with the ratchet teeth and pass through said slot at predetermined positions to free the pawl for engagement with said ratchet teeth.

5. In combination, two telescoping members, the outer of said members having a slot in one side thereof and ratchet teeth opposite the slot, said slot having enlargements at its ends; a pawl pivoted in the inner of said members with one end adapted to engage the ratchet teeth and its other end engaging said slot; a pin on the pawl adapted to pass through the enlargements at the ends of said slot; a spring connected with said pawl for moving the pin through the enlargement at one end of the slot; and a member at the other end of said slot for moving said pin back through said slot into the outer member.

In testimony whereof I have signed my name to this specification, on this 20th day of July A. D. 1917.

HAROLD G. ANTHONY.