

(12) STANDARD PATENT
(19) AUSTRALIAN PATENT OFFICE

(11) Application No. **AU 2013277497 B2**

(54) Title
Helmet cover assembly having at least one mounting device

(51) International Patent Classification(s)
A42B 3/00 (2006.01)

(21) Application No: **2013277497** (22) Date of Filing: **2013.06.17**

(87) WIPO No: **WO13/192070**

(30) Priority Data

(31) Number	(32) Date	(33) Country
61/660,926	2012.06.18	US

(43) Publication Date: **2013.12.27**

(44) Accepted Journal Date: **2016.01.21**

(71) Applicant(s)
Gentex Corporation

(72) Inventor(s)
Long, Richard J.

(74) Agent / Attorney
Freehills Patent Attorneys, Level 43 101 Collins Street, Melbourne, VIC, 3000

(56) Related Art
US 5052054



- (51) International Patent Classification:
A42B 3/00 (2006.01)
- (21) International Application Number:
PCT/US2013/046081
- (22) International Filing Date:
17 June 2013 (17.06.2013)
- (25) Filing Language: English
- (26) Publication Language: English
- (30) Priority Data:
61/660,926 18 June 2012 (18.06.2012) US
- (71) Applicant: GENTEX CORPORATION [US/US]; 324
Main Street, Carbondale, PA 18704 (US).
- (72) Inventor: LONG, Richard, J.; 198 The Hideout, Lake Ariel,
PA 19436 (US).
- (74) Agents: HEMMER, John, L. et al.; Morgan, Lewis &
Bockius, LLP, 1701 Market Street, Philadelphia, PA
19103 (US).
- (81) Designated States (unless otherwise indicated, for every
kind of national protection available): AE, AG, AL, AM,
AO, AT, AU, AZ, BA, BB, BG, BH, BN, BR, BW, BY,

BZ, CA, CH, CL, CN, CO, CR, CU, CZ, DE, DK, DM, DO, DZ, EC, EE, EG, ES, FI, GB, GD, GE, GH, GM, GT, HN, HR, HU, ID, IL, IN, IS, JP, KE, KG, KN, KP, KR, KZ, LA, LC, LK, LR, LS, LT, LU, LY, MA, MD, ME, MG, MK, MN, MW, MX, MY, MZ, NA, NG, NI, NO, NZ, OM, PA, PE, PG, PH, PL, PT, QA, RO, RS, RU, RW, SC, SD, SE, SG, SK, SL, SM, ST, SV, SY, TH, TJ, TM, TN, TR, TT, TZ, UA, UG, US, UZ, VC, VN, ZA, ZM, ZW.

(84) Designated States (unless otherwise indicated, for every kind of regional protection available): ARIPO (BW, GH, GM, KE, LR, LS, MW, MZ, NA, RW, SD, SL, SZ, TZ, UG, ZM, ZW), Eurasian (AM, AZ, BY, KG, KZ, RU, TJ, TM), European (AL, AT, BE, BG, CH, CY, CZ, DE, DK, EE, ES, FI, FR, GB, GR, HR, HU, IE, IS, IT, LT, LU, LV, MC, MK, MT, NL, NO, PL, PT, RO, RS, SE, SI, SK, SM, TR), OAPI (BF, BJ, CF, CG, CI, CM, GA, GN, GQ, GW, KM, ML, MR, NE, SN, TD, TG).

Published:
— with international search report (Art. 21(3))
— before the expiration of the time limit for amending the claims and to be republished in the event of receipt of amendments (Rule 48.2(h))

(54) Title: HELMET COVER ASSEMBLY HAVING AT LEAST ONE MOUNTING DEVICE

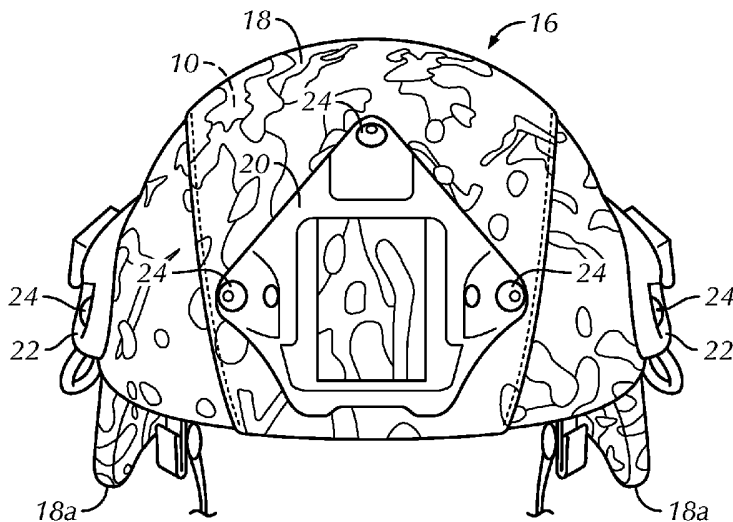

FIG. 2

(57) Abstract: A helmet cover includes a cover configured to extend over a helmet and at least one mount attached to the cover. In one embodiment, a backing plate is coupled to the at least one mount and the cover is sandwiched between the backing plate and the at least one mount.



TITLE OF THE INVENTION

[0001] Helmet Cover Assembly Having at Least One Mounting Device

CROSS-REFERENCE TO RELATED APPLICATIONS

[0002] This application claims the benefit of U.S. Provisional Patent Application No. 61/660,926 filed June 18, 2012 entitled "Helmet Cover Assembly Having At Least One Mounting Device", incorporated by reference herein in its entirety.

BACKGROUND OF THE INVENTION

[0003] The present invention generally relates to a helmet cover assembly having at least one mounting device.

BRIEF SUMMARY OF THE INVENTION

[0004] In a first aspect of the invention there is a helmet cover assembly for covering a helmet having an exterior surface, an inside surface that is opposite the exterior surface, and a bottom edge, the helmet cover assembly comprising a cover comprised of a flexible material and configured to extend over the exterior surface of the helmet, wrap around the bottom edge of the helmet, and releasably couple to the inside surface of the helmet to fit the cover to a contour of the exterior surface of the helmet; and at least one mounting device attached to the cover.

[0004a] In a second aspect, there is provided a helmet cover assembly comprising a cover comprised of a flexible material, the cover configured to extend over an entire exterior surface of a helmet, correspond to the entire contour of the exterior surface of the helmet and extend over a bottom edge of the helmet; one or more hook and pile fasteners attached to the cover and configured to releasably couple the cover to an inside surface of the helmet; and a night vision goggle mount and two side rail mounts attached to the cover.

[0004b] In a third aspect, there is provided a helmet assembly comprising a ballistics helmet having a bottom edge, an exterior surface and an interior surface; a cover comprised of a flexible material and configured to extend over the exterior surface of the helmet, extend over the bottom edge of the helmet, and releasably couple to an inside surface of the helmet; and at least one

mounting device attached to the cover, the at least one mounting device including one or more of a rail and a shroud.

[0004c] In an embodiment, the helmet cover includes a backing plate coupled to the at least one mounting device. In one embodiment, the cover is sandwiched between the backing plate and the at least one mounting device. In one embodiment, the backing plate is coupled to two or more of the at least one mounting device. In one embodiment, an outer periphery of the backing plate extends past an outer periphery of at least one of the at least one mounting device. In one embodiment, the backing plate has a contour that matches a corresponding contour of the helmet. In one embodiment, the cover couples the backing plate and at least one mounting device to the helmet. In one embodiment, the backing plate extends at least half way around a periphery of the helmet.

[0005] In one embodiment, the cover is coupled to the helmet by one or more fasteners. In one embodiment, the one or more fasteners includes one or more hook and pile fasteners configured to attach to an inside surface of the helmet. In one embodiment, the at least one mount includes a night vision goggle mount. In one embodiment, the at least one mount includes at least one side rail mount. In one embodiment, the at least one mount includes a night vision goggle mount and two side rail mounts. In one embodiment, the cover extends over an entire outer surface of the helmet. In one embodiment, the cover extends over a bottom edge of the helmet and is releasably coupled to an inside surface of the helmet. In one embodiment, the cover is attachable to the helmet using only hook and pile fasteners. In one embodiment, the cover is comprised of a non-elastic material.

BRIEF DESCRIPTION OF THE SEVERAL VIEWS OF THE DRAWINGS

[0006] The following detailed description of embodiments of the helmet cover assembly, will be better understood when read in conjunction with the appended drawings of an exemplary embodiment. It should be understood, however, that the invention is not limited to the precise arrangements and instrumentalities shown.

[0007] In the drawings:

[0008] Fig. 1 is a side perspective view of a prior art helmet;

[0009] Fig. 2 is a front view of a helmet cover assembly in accordance with an exemplary embodiment of the present invention shown on a helmet;

[0010] Fig. 3 is a side view of the helmet cover shown in Fig. 2;

[0011] Fig. 4 is a bottom view of the helmet cover shown in Fig. 2;

[0012] Fig. 5 is a perspective view of the helmet cover shown in Fig. 2 removed from the helmet and without the cover; and

[0013] Fig. 6 is a partial bottom view of the helmet cover shown in Fig. 2 removed from the helmet.

DETAILED DESCRIPTION OF THE INVENTION

[0014] Referring to the drawings in detail, wherein like reference numerals indicate like elements throughout, there is shown in Figs. 2-8 a helmet cover assembly, generally designated 16, in accordance with an exemplary embodiment of the present invention.

[0015] Helmets for head protection are worn in a variety of environments and for various purposes including adventure, sporting, police and military purposes. An exemplary ballistic helmet used in the military is shown in Fig. 1. Accessories may be added or attached to the helmet according to the needs of the wearer and the demands of the environment in which the helmet is to be used. Accessories may include night vision goggles, lights, strobe lights, face shields, neck protection, headsets, video cameras, sunglasses, goggles, oxygen masks and other devices. The method of attaching accessories may include attaching a mount to the helmet shell. The accessory may be releaseably coupled to the mount so the accessory can be removed from the helmet when not in use. Mounts are typically attached to helmet shell 10 by using screws or snaps requiring holes to be drilled in the shell or straps that are clamped or clipped to an edge 10b of helmet shell 10.

[0016] Referring to Figs. 2 and 3, in one embodiment, helmet cover assembly 16 includes one or more mounting devices 20, 22 that are secured to a cover 18 for attachment of accessory

components 26. Referring to Fig. 5 and 6, in some embodiments, one or more mounting devices 20, 22 are attached to cover 18 through the use of fasteners 24 and one or more backing plates 30 with cover 18 sandwiched in between mounting devices 20, 22 and backing plates 30. Referring to Figs. 2 and 4, in some embodiments, cover 18 extends over an exterior 10a (see Fig. 1) of a helmet shell 10 and attaches via one or more fasteners 28 on the inside surface of helmet shell 10. Cover 18 may be sized and shaped to be snug or otherwise secured to exterior 10a of helmet shell 10 to minimize the movement of mounting devices 20, 22 relative to helmet shell 10 during use.

[0017] In some embodiments, attaching mounting devices 20, 22 to helmet cover assembly 16 rather than directly to helmet shell 10 eliminates or at least reduces the need to drill mounting holes in helmet shell 10 that may affect the performance properties of helmet shell 10. In some embodiments, attaching mounting devices 20, 22 to helmet cover assembly 16 rather than directly to helmet shell 10 allows a user to more quickly mount and remove mounting devices 20, 22 to and from helmet shell 10. In some embodiments, attaching mounting devices 20, 22 to helmet cover assembly 16 rather than directly to helmet shell 10 allows a user to more quickly exchange a mounting configuration for a different mounting configuration. In some embodiments, attaching mounting devices 20, 22 to helmet cover assembly 16 rather than directly to helmet shell 10 allows a user to quickly install all of the necessary mounting device 20, 22 at once rather than attach each mounting device 20, 22 individually. In some embodiments, attaching mounting devices 20, 22 to helmet cover assembly 16 rather than directly to helmet shell 10 allows a user to attach one or more mounting devices to helmet shell 10 without the use of tools. In some embodiments, attaching mounting devices 20, 22 to helmet cover assembly 16 rather than directly to helmet shell 10 allows a user to incorporate the appropriate camouflage pattern or color to helmet shell 10.

[0018] Referring to Figs. 2 and 3, in one embodiment, the material used for cover 18 is configured to provide a stable base for attaching mounting devices 20, 22 to helmet shell 10. Cover 18 may extend over the entire exterior surface 10a of helmet shell 10. In one embodiment, cover 18 extends substantially over the entire exterior surface 10a of helmet shell 10. In other embodiments, cover 18 includes one or more openings to expose one or more portions of exterior surface 10a of helmet shell 10. Cover 18 may be resistant to tearing, ripping and stretching. In one embodiment, cover 18 is non-elastic. In one embodiment, cover 18 is flexible. In one embodiment, cover 18 is comprised of a textile. In one embodiment, cover 18 is comprised of a fabric. In one embodiment, cover 18 is comprised of canvas. In one embodiment, cover 18 is comprised of ripstop. In one embodiment, cover 18 is comprised of twill. Cover 18 may include a pattern or image. In one embodiment, cover 18 is camouflage patterned.

[0019] Referring to Figs. 5 and 6, in some embodiments, one or more backing plates 30 are used to attach the mounting devices 20, 22 to cover 18. Cover 18 may be sandwiched between backing plate 30 and mounting devices 20, 22. In one such embodiment, outer surface 30b of backing plate 30 contacts mounting devices 20, 22 and inner surface 30a of backing plate 30 contacts exterior surface 10a of helmet shell 10. Alternatively, backing plate 30 may be positioned in between layers of cover 18 such that the entire thickness of cover 18 is only partially sandwiched between backing plate 30 and mounting devices 20, 22. In one such embodiment, only cover 18 contacts exterior surface 10a of helmet shell 10. Backing plate 30 may be provided to help secure mounting devices 20, 22 to cover 18. Backing plate 30 may be provided to stabilize mounting devices 20, 22 relative to helmet shell 10. In one embodiment, backing plate 30 is stiffer than cover 18. In one embodiment, backing plate 30 is flexible enough to generally conform to the shape of helmet shell 10 while strong enough to prevent mounting devices 20, 22 from detaching from cover 18. In some embodiments, backing plate 30 is substantially rigid. In some embodiments, backing plate 30 is pre-shaped to match the contour of helmet shell 10.

[0020] In one embodiment, backing plate 30 is comprised of a thermoset plastic. In one embodiment, backing plate 30 is comprised of acrylonitrile butadiene styrene. In one embodiment, backing plate 30 is comprised of polyethylene. In one embodiment, backing plate 30 is comprised of KYDEX®, or acrylic-polyvinyl chloride materials. In one embodiment, backing plate 30 is comprised of 0.030 inch thick, grade 1, class M polyethylene. In one embodiment, backing plate 30 is comprised of 0.040 inch thick, grade 1, class L polyethylene. In one embodiment, backing plate 30 is comprised of 0.032 inch thick virgin acrylonitrile butadiene styrene, spectrum #250, type B210 B33420 such as ROYALITE®. In some embodiments, backing plate 30 is comprised of metal. In some embodiments, backing plate 30 is comprised of aluminum. In one embodiment, backing plate 30 is approximately .060 inches thick.

[0021] Backing plate 30 may be a single component that is secured to two or more mounting devices 20, 22. The footprint of backing plate 30 may be larger than the footprint of mounting devices 20, 22. In one embodiment, backing plate 30 extends more than half way around the periphery of helmet shell 10. In one embodiment, backing plate 30 extends around the entire periphery of helmet shell 10. In one embodiment, backing plate 30 extends approximately three quarters of the way around the periphery of helmet shell 10. In one embodiment, backing plate 30 generally matches the outer perimeter of mounting devices 20, 22. In one embodiment, backing plate 30 generally matches the outer contour of mounting devices 20, 22 and extends between mounting devices 20, 22 in order to connect mounting devices 20, 22 to one another. In one

embodiment, mounting devices 20, 22 are attached to backing plate 30 and then the backing plate 30 is trimmed to generally match the outer contour of mounting devices 20, 22. Attaching mounting devices 20, 22 relative to one another through backing plate 30 may help to minimize movement of cover 18 and make the backing plate 30 stronger.

5 [0022] In other embodiments, each mounting device 20, 22 has a separate backing plate 30. In some embodiments, separate backing plates 30 are attached to one another to form a single base. In one embodiment, adjacent backing plates 30 are coupled to one another at an adjustable length. Providing an adjustable length between backing plates 30 may allow for use with different sized helmet shells 10. In one embodiment, adjacent backing plates 30 are coupled to one another using
10 overlapping hook and pile portions. In one embodiment, adjacent backing plates 30 are coupled to one another using a strap having one or more adjustment slides.

[0023] Referring to Figs. 2, 5 and 6, in one embodiment, mounting devices 20, 22 are attached to backing plate 30 using one or more fasteners 24. In one embodiment, backing plate 30 includes one or more holes for accepting fasteners 24. In one embodiment, at least a portion of cover 18 is
15 positioned between backing plate 18 and mounting device 20, 22 and one or more fasteners is added to secure the assembly together. In one embodiment, fasteners 24 include a nut or plate 24a configured to secure fastener 24 to backing plate 30. In one embodiment, plate 24a is generally flush with backing plate 30. In one embodiment, plate 24a is at least twice as wide as the diameter of hole through which fastener 24 extends through. Plate 24a may be configured to prevent fastener
20 24 from being pulled through backing plate 30. In one embodiment, fasteners 24 are rivets. In one embodiment, fasteners 24 include a screw. In one embodiment, fasteners 24 are grommets. In one embodiment, fasteners 24 include a fastener used to secure a mounting device 20, 22 directly to helmet shell 10. In one embodiment, fasteners 24 include a projection from backing plate 30 or mounting device 20, 22 that is heat welded to fasten backing plate 30 and mounting device 20, 22
25 together.

[0024] Referring to Fig. 2, in some embodiments, cover 18 may include one or more prefabricated slots or holes for receiving fasteners 24. Such openings may have a sewn edge or are seared to prevent fraying of cover 18 around the periphery of the opening. In other embodiments, no pre-existing holes are provided in cover 18 and fasteners 24 are forced through cover 18. In some
30 embodiments, backing plate 30 is secured to cover 18. In one embodiment, backing plate 30 is sewn to cover 18. In one embodiment, backing plate 30 is glued to cover 18. In one embodiment, fasteners in addition to fasteners 24 are used to secure backing plate 30 to cover 18. Cover 18 may include one or more pockets for retraining at least a portion of backing plate 30.

[0025] Referring to Fig. 4, in one embodiment, cover 18 attaches helmet cover assembly 16 to helmet shell 10. In one embodiment, only cover 18 couples mounting devices 20, 22 to helmet shell 10. In one embodiment, cover 18 wraps around bottom edge 10b of helmet shell 10. In one embodiment, cover 18 wraps around the entire bottom edge 10b of helmet shell 10. In one
5 embodiment, helmet cover assembly 16 includes one or more fasteners 28 to secure cover 18 to helmet shell 10. In one embodiment, cover 18 and fasteners 28 are configured to substantially prevent movement of cover 18 relative to helmet shell 10. In one embodiment, cover 18 is pulled into a snug relationship with helmet shell 10 before attaching cover 18 to helmet shell 10 with fasteners 28. In one embodiment, cover 18 is shaped such that once cover 18 is in place on helmet
10 shell 10, cover 18 snugly fits onto helmet shell 10.

[0026] In one embodiment, fasteners 28 include one or more hook and pile strips attached proximate to edge 18a of cover 18. In one embodiment, cover 18 includes a plurality of fasteners 28 spaced around edge 18a. In one embodiment, fasteners 28 include corresponding fasteners mounted to the inside surface of helmet shell 10 proximate a bottom edge 10b. The corresponding fasteners
15 mounted to the inside surface of helmet shell 10 may include preexisting fasteners such as those used to retain padding 32. In other embodiments, additional corresponding fasteners are provided. In other embodiments, cover 18 may include a strap or elastic band to retain cover 18 to helmet shell 10. In one embodiment, cover 18 includes one or more clips to secure cover 18 to edge 10b of the helmet shell 10.

[0027] In one embodiment, cover 18 retains helmet cover assembly 16 to helmet shell 10 without any fasteners extending into helmet shell 10. In one embodiment, cover assembly 16 is mountable onto helmet shell 10 without the use of tools. In one embodiment, cover 18 retains helmet cover assembly 16 to helmet shell 10 without having to modify the original helmet. In one
20 embodiment, cover 18 retains helmet cover assembly 16 to helmet shell 10 without having to drill additional holes into helmet shell 10. In one embodiment, one or more pre-existing fasteners 12 (See Fig. 1) or a fastener configured to use the pre-existing helmet holes, may be configured to extend through backing plate 30 to further secure helmet cover assembly 16 to helmet shell 10. For
25 example, pre-existing fasteners 12 used to secure chinstrap 14 to helmet shell 10 may be replaced with longer fasteners configured to extend through mounting device 22, cover 18, and backing plate 30 to further secure helmet cover assembly 16 to helmet shell 10.
30

[0028] Helmet cover assembly 16 may be configured such that it can substantially support the weight of and forces exerted on the accessories as if mounting devices 20, 22 were attached directly to helmet shell 10.

[0029] Referring to Figs. 2 and 3, in some embodiments, mounting devices 20, 22 may include but are not limited to one or more mounting devices such as rails (e.g., an ARC or Picatinny rail) and/or night vision goggle (“NVG”) mounts. Fig. 2 shows an exemplary embodiment having one NVG mount and two side ARC rails. In one embodiment, one or more additional helmet cover assemblies 16 may be provided in order to attach different mounting mechanisms 20, 22 and/or a different color or patterned cover 18 and/or mounting devices 20, 22. Since mounting devices 20, 22 are typically attached directly to helmet shell 10 or other platform surface, they may be contoured to match exterior surface 10a of helmet shell 10. In some embodiments, matching the contour of helmet shell 10 is not necessary as backing plate 30 can be configured to match exterior surface 10a of helmet shell 10 while attaching to whatever contour the mounting device may have.

[0030] In one embodiment, cover 18 is configured to make mounting devices 20, 22 more flush with the helmet as compared to attaching the same mounting devices 20, 22 directly to helmet shell 10. In one embodiment, cover 18 is configured to cover or reduce the distance that an edge or projection on mounting devices 20, 22 extend from helmet shell 10 and could catch on something such as a parachute shroud line when mounting device 20, 22 is not attached with an accessory.

[0031] In addition to mounting devices 20, 22, in some embodiments, cover 18 also includes pile tape, goggle retaining straps, IR patches, battery pouch or other items to support user requirements.

[0032] It will be appreciated by those skilled in the art that changes could be made to the exemplary embodiments shown and described above without departing from the broad inventive concept thereof. It is understood, therefore, that this invention is not limited to the exemplary embodiments shown and described, but it is intended to cover modifications within the spirit and scope of the present invention as defined by the claims. For example, specific features of the exemplary embodiments may or may not be part of the claimed invention and features of the disclosed embodiments may be combined. Unless specifically set forth herein, the terms “a”, “an” and “the” are not limited to one element but instead should be read as meaning “at least one”.

[0033] It is to be understood that at least some of the figures and descriptions of the invention have been simplified to focus on elements that are relevant for a clear understanding of the invention, while eliminating, for purposes of clarity, other elements that those of ordinary skill in the art will appreciate may also comprise a portion of the invention. However, because such elements are well known in the art, and because they do not necessarily facilitate a better understanding of the invention, a description of such elements is not provided herein.

CLAIMS

1. A helmet cover assembly for covering a helmet having an exterior surface, an inside surface that is opposite the exterior surface, and a bottom edge, the helmet cover assembly comprising:

a cover comprised of a flexible material and configured to extend over the exterior surface of the helmet, wrap around the bottom edge of the helmet, and releasably couple to the inside surface of the helmet to fit the cover to a contour of the exterior surface of the helmet; and

at least one mounting device attached to the cover.

2. The helmet cover assembly of claim 1, further comprising:

a backing plate coupled to the at least one mounting device.

3. The helmet cover assembly of claim 2, wherein the cover is sandwiched between the backing plate and the at least one mounting device.

4. The helmet cover assembly of claim 2, wherein the at least one mounting device is comprised of two or more mounting devices, wherein the two or more mounting devices are each coupled to the backing plate.

5. The helmet cover assembly of claim 2, wherein an outer periphery of the backing plate extends past an outer periphery of at least one of the at least one mounting device.

6. The helmet cover assembly of claim 2, wherein the backing plate is configured to correspond to a contour of the exterior surface of the helmet.

7. The helmet cover assembly of claim 2, wherein the cover is configured to couple the backing plate and at least one mounting device to the helmet.
8. The helmet cover assembly of claim 2, wherein the backing plate is configured to extend at least half way around a periphery of the helmet.
9. The helmet cover assembly of claim 1, wherein the cover is configured to directly couple to the inside surface of the helmet by one or more fasteners.
10. The helmet cover assembly of claim 9, wherein the one or more fasteners includes one or more hook and pile fasteners configured to attach to the inside surface of the helmet.
11. The helmet cover assembly of claim 1, wherein the at least one mounting device includes a night vision goggle mount.
12. The helmet cover assembly of claim 1, wherein the at least one mounting device includes at least one side rail mount.
13. The helmet cover assembly of claim 1, wherein the at least one mounting device is comprised of three or more mounting devices and wherein the three or more mounting devices includes a night vision goggle mount and two side rail mounts.
14. The helmet cover assembly of claim 1, wherein the cover is configured to extend over the entire exterior surface of the helmet.
15. The helmet cover assembly of claim 1, wherein the cover is configured to be attachable to the helmet using only hook and pile fasteners.

16. The helmet cover assembly of claim 1, wherein the flexible material is comprised of a non-elastic material.

17. The helmet cover assembly of claim 1, wherein the flexible material is comprised of a fabric.

18. The helmet cover assembly of claim 1, wherein the flexible material is comprised of canvas.

19. The helmet cover assembly of claim 1, wherein the cover is configured to extend substantially over the entire exterior surface of the helmet.

20. The helmet cover assembly of claim 1, wherein the cover is configured to fit snug to an exterior surface of at least two different sized or shaped helmets.

21. The helmet cover assembly of claim 1, wherein the at least one mounting device is positioned entirely above the bottom edge of the helmet.

22. A helmet cover assembly comprising:

a cover comprised of a flexible material, the cover configured to extend over an entire exterior surface of a helmet, correspond to the entire contour of the exterior surface of the helmet and extend over a bottom edge of the helmet;

one or more hook and pile fasteners attached to the cover and configured to releasably couple the cover to an inside surface of the helmet; and

a night vision goggle mount and two side rail mounts attached to the cover.

23. A helmet assembly comprising:

a ballistics helmet having a bottom edge, an exterior surface and an interior surface;

a cover comprised of a flexible material and configured to extend over the exterior surface of the helmet, extend over the bottom edge of the helmet, and releasably couple to an inside surface of the helmet; and

at least one mounting device attached to the cover, the at least one mounting device including one or more of a rail and a shroud.

1/3

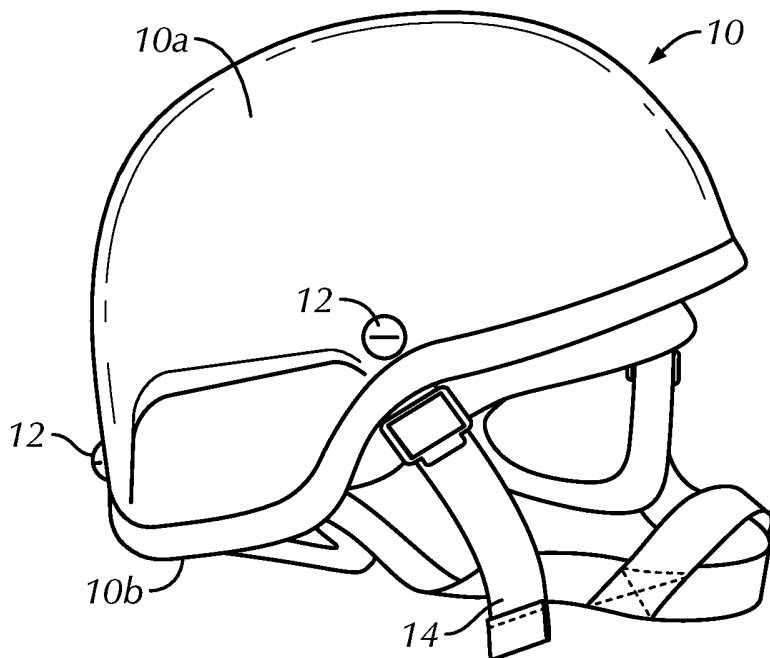

FIG. 1
(Prior Art)

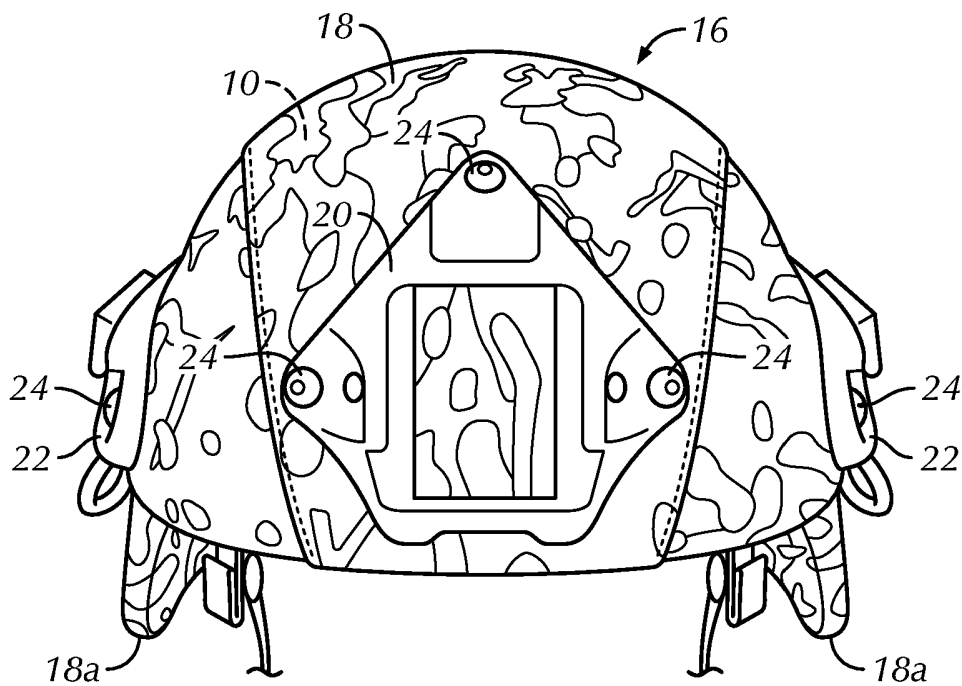

FIG. 2

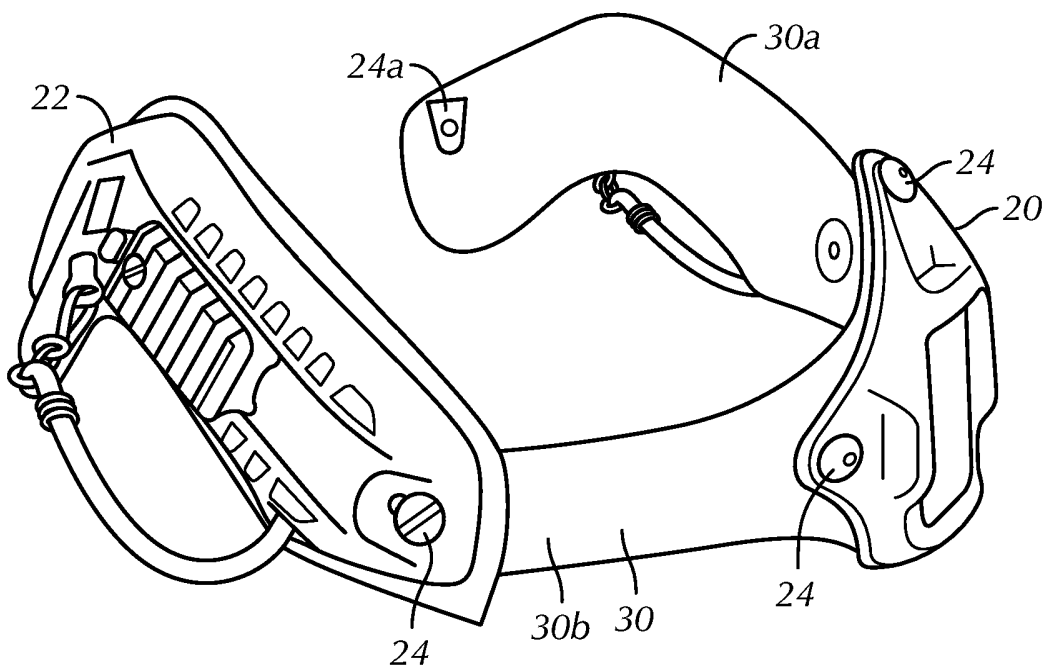

FIG. 5

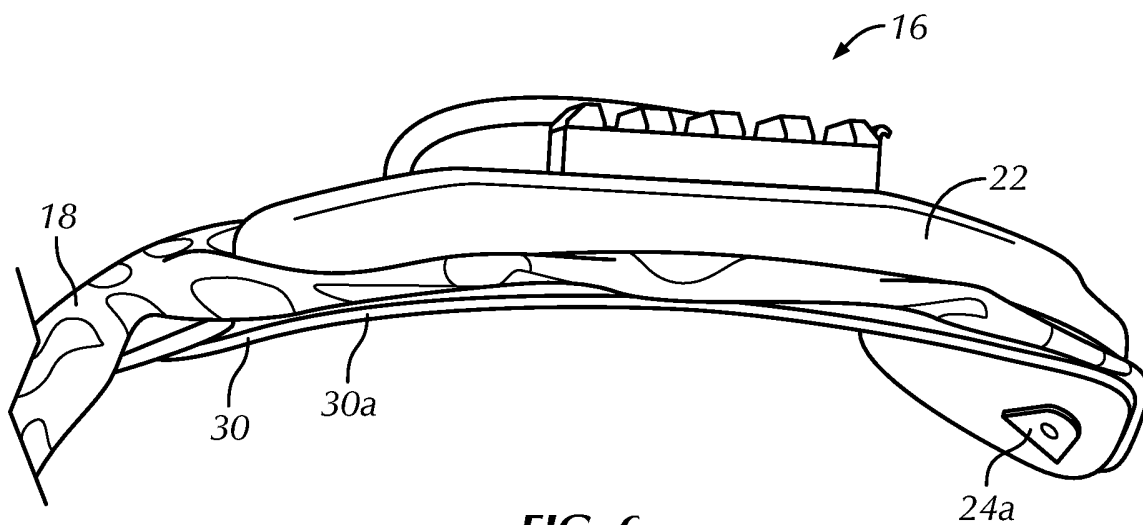

FIG. 6