



US00D739840S

(12) **United States Design Patent**
Park et al.

(10) **Patent No.:** **US D739,840 S**

(45) **Date of Patent:** **** Sep. 29, 2015**

(54) **TELEVISION RECEIVER**

FOREIGN PATENT DOCUMENTS

(71) Applicant: **LG Electronics Inc.**, Seoul (KR)

KR 30-0672766 12/2012
KR 30-0673553 12/2012

(72) Inventors: **Sunha Park**, Seoul (KR); **Junki Kim**,
Seoul (KR); **Youngyoung Kim**, Seoul
(KR); **Minji Seo**, Gyeonggi-do (KR)

(Continued)

(73) Assignee: **LG Electronics Inc.**, Seoul (KR)

OTHER PUBLICATIONS

(**) Term: **14 Years**

Publication Date: Jan. 8, 2008, <http://crave.cnet.co.uk/desktops/crave-tv-alienwares-bad-boy-alx-pc-and-curved-display-49294958/>.

(Continued)

(21) Appl. No.: **29/461,385**

Primary Examiner — Raphael Barkai
(74) *Attorney, Agent, or Firm* — Morgan, Lewis & Bockius
LLP

(22) Filed: **Jul. 23, 2013**

(57) **CLAIM**

(30) **Foreign Application Priority Data**

The ornamental design for a television receiver, as shown and described.

Jan. 24, 2013 (KR) 30-2013-0004248

DESCRIPTION

(51) **LOC (10) Cl.** **14-03**

(52) **U.S. Cl.**
USPC **D14/126**

(58) **Field of Classification Search**

USPC D14/125–134, 239, 371, 136, 374–377,
D14/440, 450, 448, 336, 342, 159; 312/7.2;
348/836, 838, 180, 184, 325, 739;
248/917–924, 465; 345/104, 133, 156,
345/168, 87, 173; D21/329, 515, 577, 622,
D21/333, 433, 448, 452, 450, 331, 505;
D10/15, 26; 446/484, 175, 356;
D6/477, 479, 300; D24/185; D34/14
CPC ... G06F 1/1601; G06F 1/1643; H05K 5/0004;
H05K 5/0017; H05K 5/02; H05K 5/0217

See application file for complete search history.

FIG. 1 is a perspective view of a television receiver showing our new design;
FIG. 2 is a front view thereof;
FIG. 3 is a rear view thereof;
FIG. 4 is a left side view thereof where the right side view is a mirror image;
FIG. 5 is a top plan view thereof;
FIG. 6 is a bottom plan view thereof;
FIG. 7 is a rear perspective view thereof;
FIG. 8 is a perspective view thereof in the middle of the TV display being curved;
FIG. 9 is a left side view thereof of FIG. 8;
FIG. 10 is a top plan view thereof of FIG. 8;
FIG. 11 is a bottom plan view thereof of FIG. 8;
FIG. 12 is a rear perspective view thereof of FIG. 8;
FIG. 13 is a side perspective view thereof of FIG. 8;
FIG. 14 is a perspective view thereof when the TV display is completely curved;
FIG. 15 is a left side view thereof of FIG. 14;
FIG. 16 is a top plan view thereof of FIG. 14;
FIG. 17 is a bottom plan view thereof of FIG. 14;
FIG. 18 is a rear perspective view thereof of FIG. 14; and
FIG. 19 is a side perspective view thereof of FIG. 14.
The broken lines are for illustrative purposes only and form no part of the claimed design.

(56) **References Cited**

U.S. PATENT DOCUMENTS

D541,772 S * 5/2007 Kita D14/126
D545,779 S * 7/2007 Kita D14/126

(Continued)

1 Claim, 16 Drawing Sheets

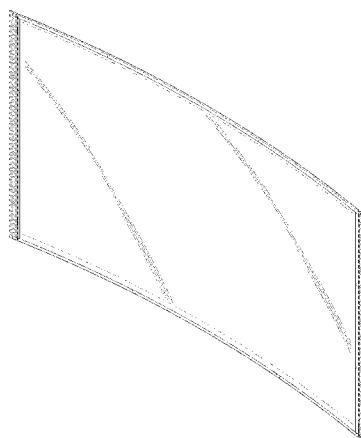
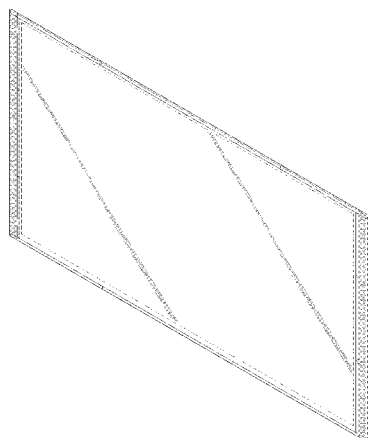

(56)

References Cited

OTHER PUBLICATIONS

U.S. PATENT DOCUMENTS

D584,257 S * 1/2009 Kita D14/126
 D585,396 S * 1/2009 Kita D14/126
 D633,881 S * 3/2011 Yokota et al. D14/126
 D680,509 S * 4/2013 Hwangbo et al. D14/126
 D682,799 S * 5/2013 Hwang Bo et al. D14/126
 D689,033 S * 9/2013 Hwangbo et al. D14/126
 D709,468 S * 7/2014 Seo et al. D14/126
 D709,469 S * 7/2014 Ryu et al. D14/126
 D713,808 S * 9/2014 Ryu et al. D14/126
 D719,116 S * 12/2014 Bang et al. D14/126
 D719,117 S * 12/2014 Huh et al. D14/126
 D720,316 S * 12/2014 Huh et al. D14/126
 D721,666 S * 1/2015 Son et al. D14/126
 D722,989 S * 2/2015 Park et al. D14/126
 D723,487 S * 3/2015 Lee et al. D14/126
 D723,488 S * 3/2015 Seo et al. D14/126
 D724,042 S * 3/2015 Chang D14/126
 D724,555 S * 3/2015 Cha et al. D14/126

FOREIGN PATENT DOCUMENTS

KR 30-0673555 12/2012
 KR 30-0675774 1/2013

Publication Date: May 19, 2008—<http://www.trustedreviews.com/news/Shinoda-Shows-Off-12.5in-Wide-1mm-Thick-Plasma>.
 Publication Date: Nov. 6, 2009—<http://technology.nicefun.net/145-inch-curved-plasma-tv/>.
 Publication Date: Nov. 24, 2009—<http://forum.xcitefun.net/huge-curved-tv-for-gamers-ostendo-crvd-t39928.html>.
 Publication Date: Jul. 29, 2009—<http://www.paddomeng.com/forums/viewtopic.php?f=36&t=221>.
 Publication Date: Jul. 13, 2012 <http://www.bornrich.com/benny-drives-160-inch-curved-rear-screen-racing-simulator-big-daddy.html>.
 Publication Date: Jan. 8, 2009—http://www.homotron.net/2009/01/macworld_2009_nec_42_curved_ul.html.
 Publication Date: May 20, 2008—<http://gizmodo.com/392248/auo-curved-displays-ultra-thin-lcds-on-the-way>.
 Publication Date: Mar. 3, 2008—<http://www.techshout.com/hardware/2008/03/view-curved-display-imac-concept-showcased-by-nuno-teixeira/>.
 Publication Date: Jan. 9, 2013—<http://jongamk.tistory.com/2099>.

* cited by examiner

FIG. 1

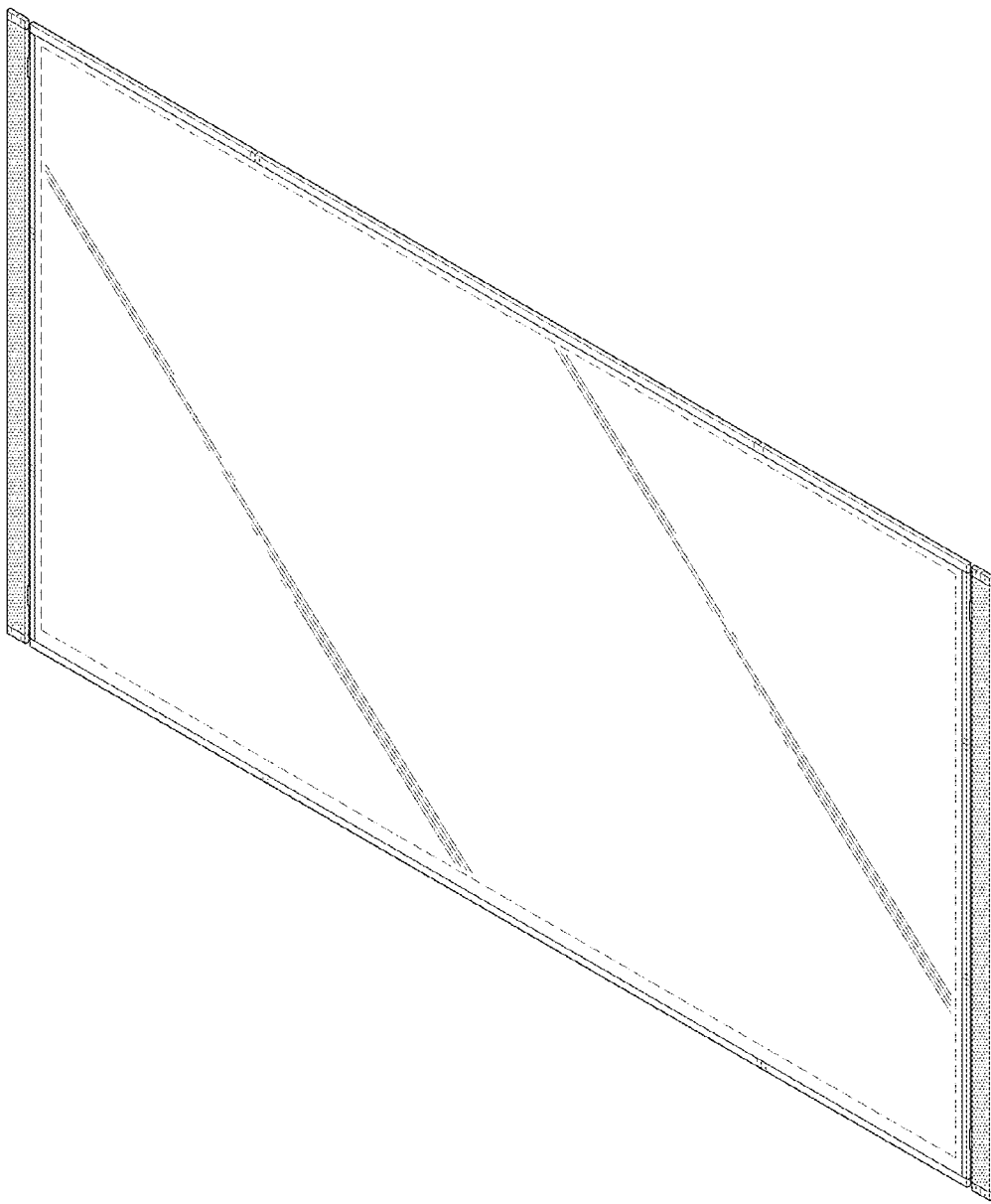

FIG. 2

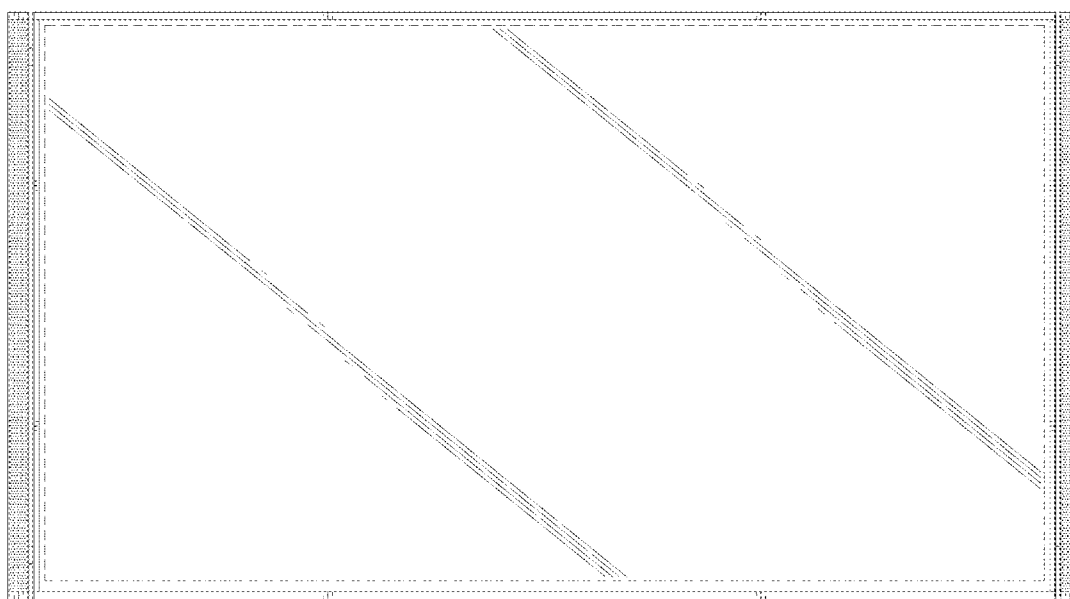

FIG. 3

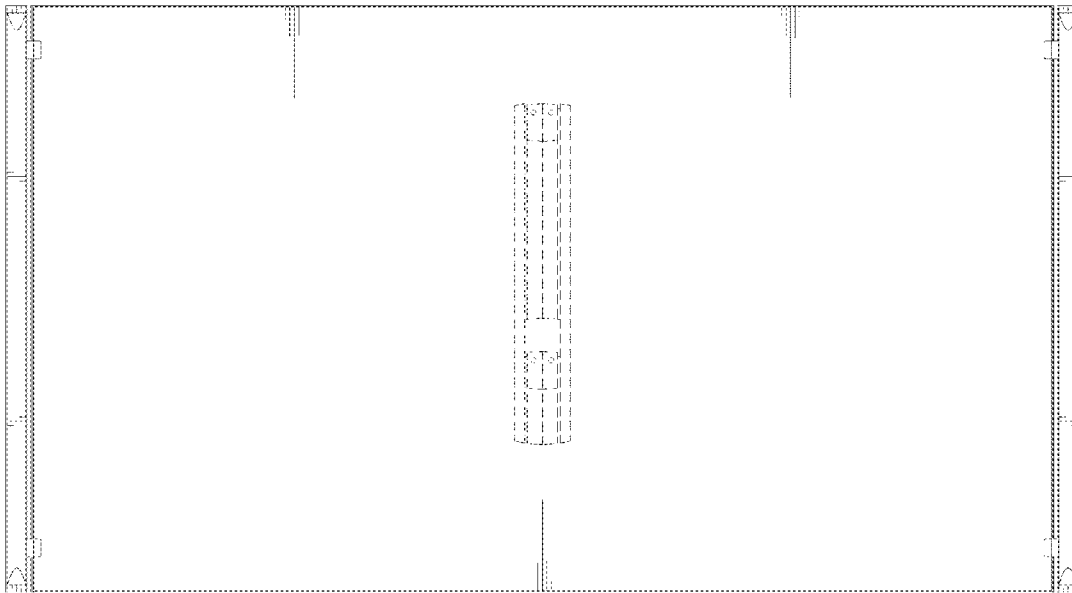

FIG. 4



FIG. 5

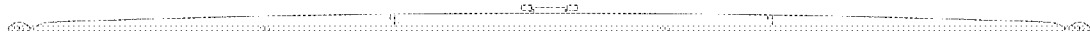

FIG. 6



FIG. 7

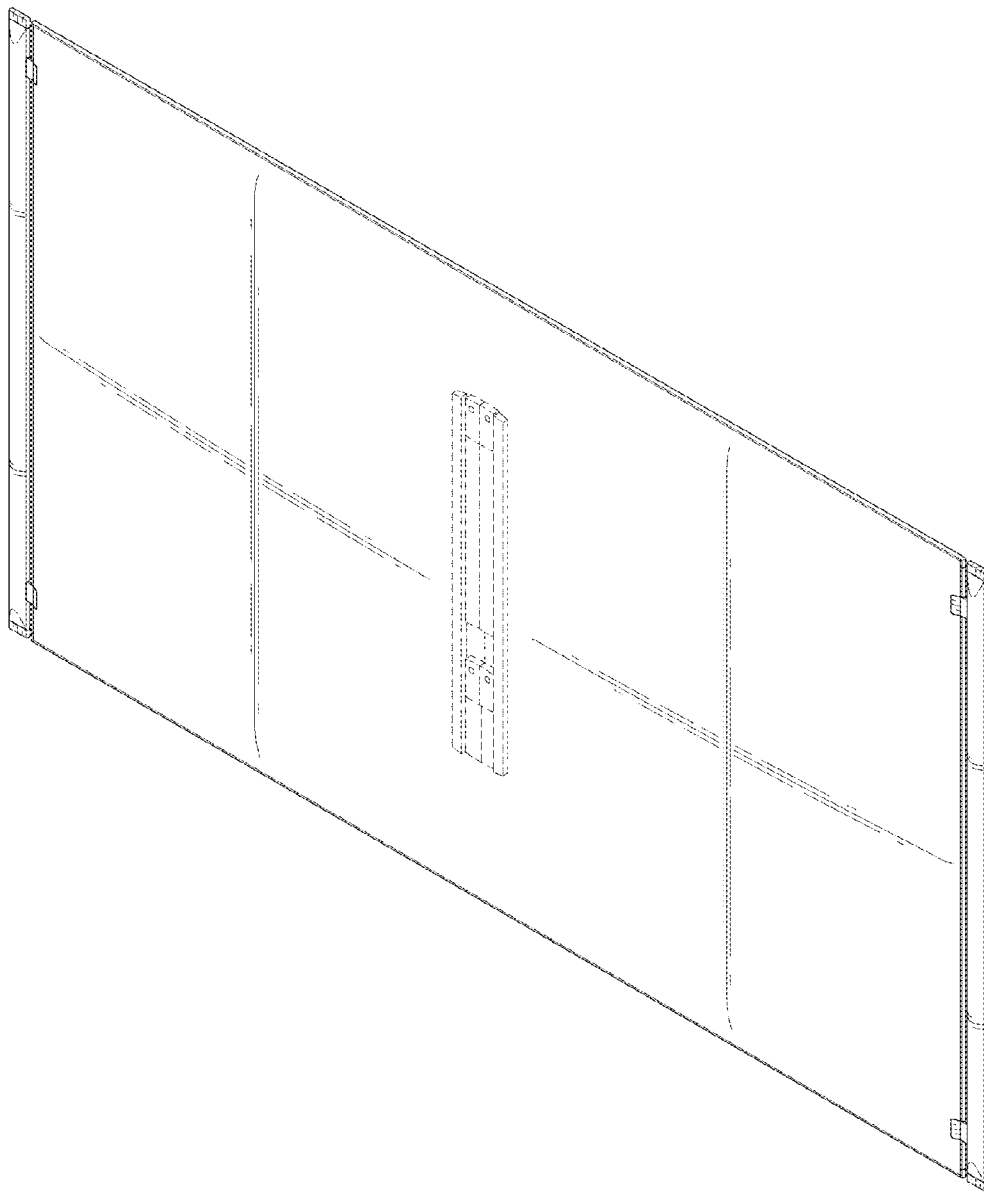

FIG. 8

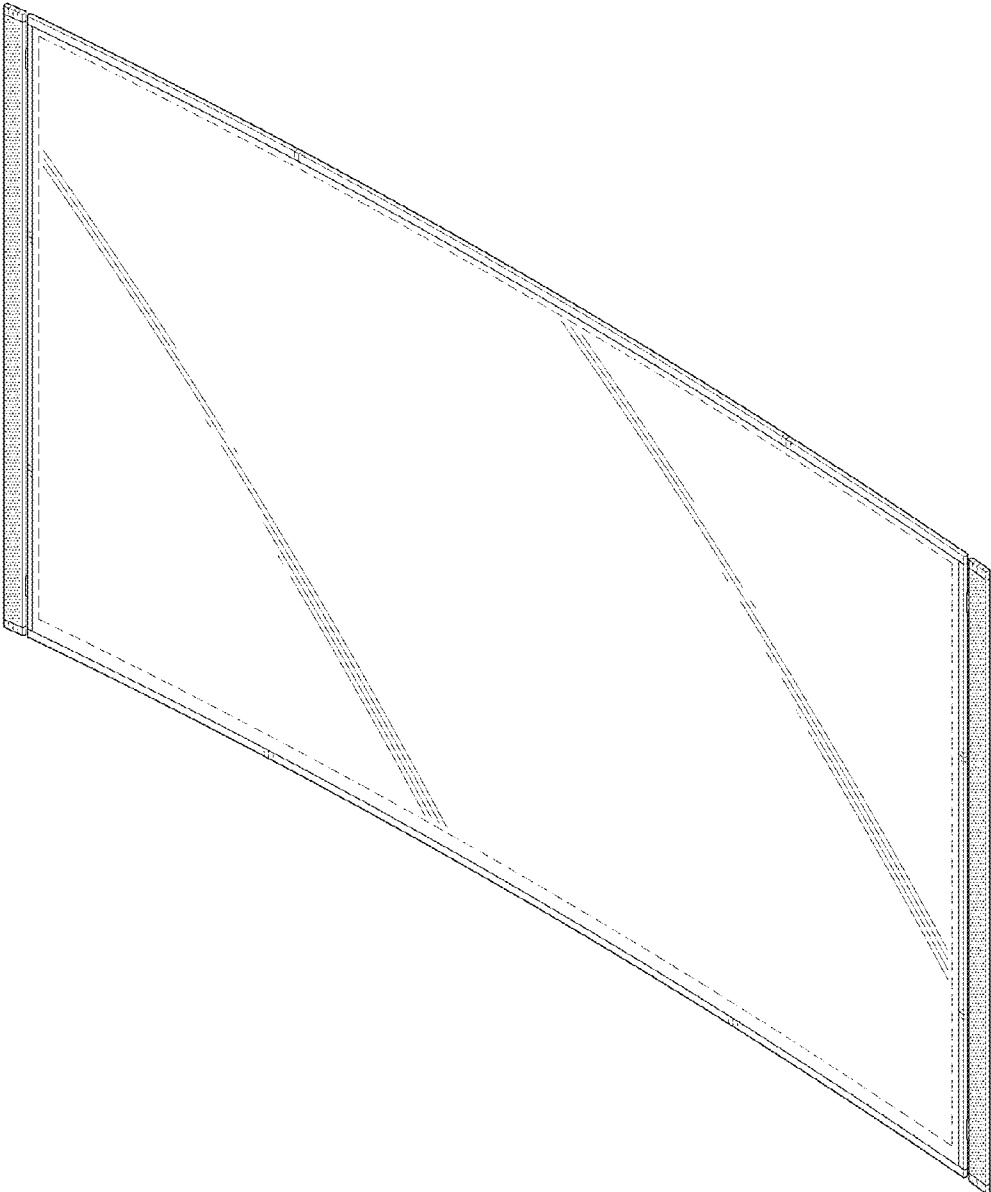

FIG. 9

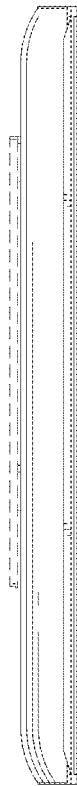

FIG. 10

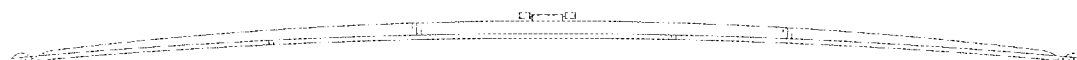

FIG. 11



FIG. 12

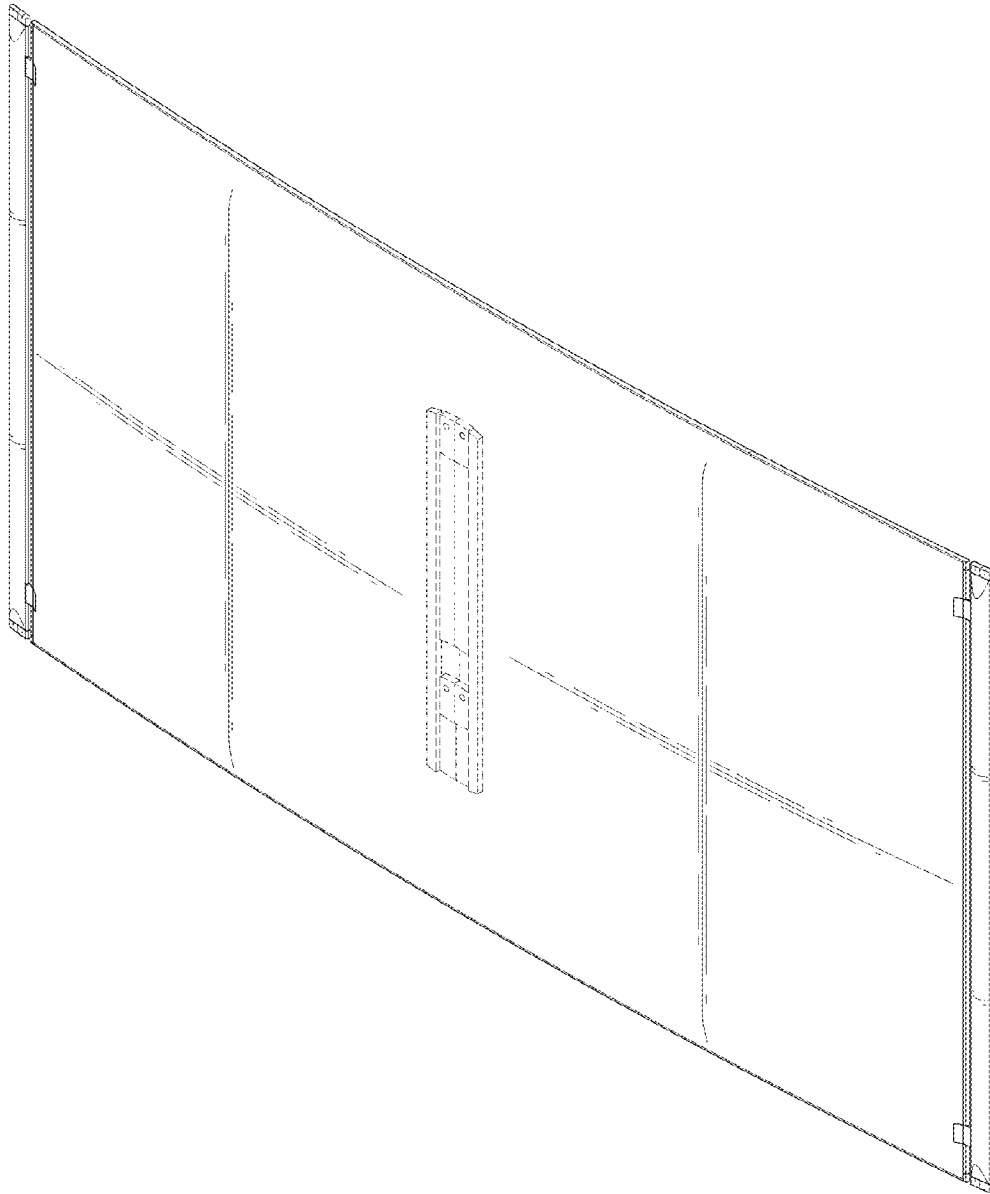

FIG. 13

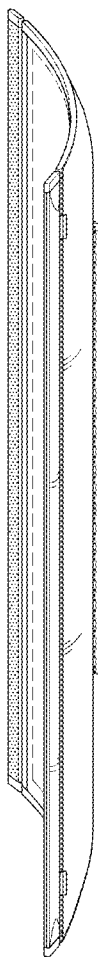

FIG. 14

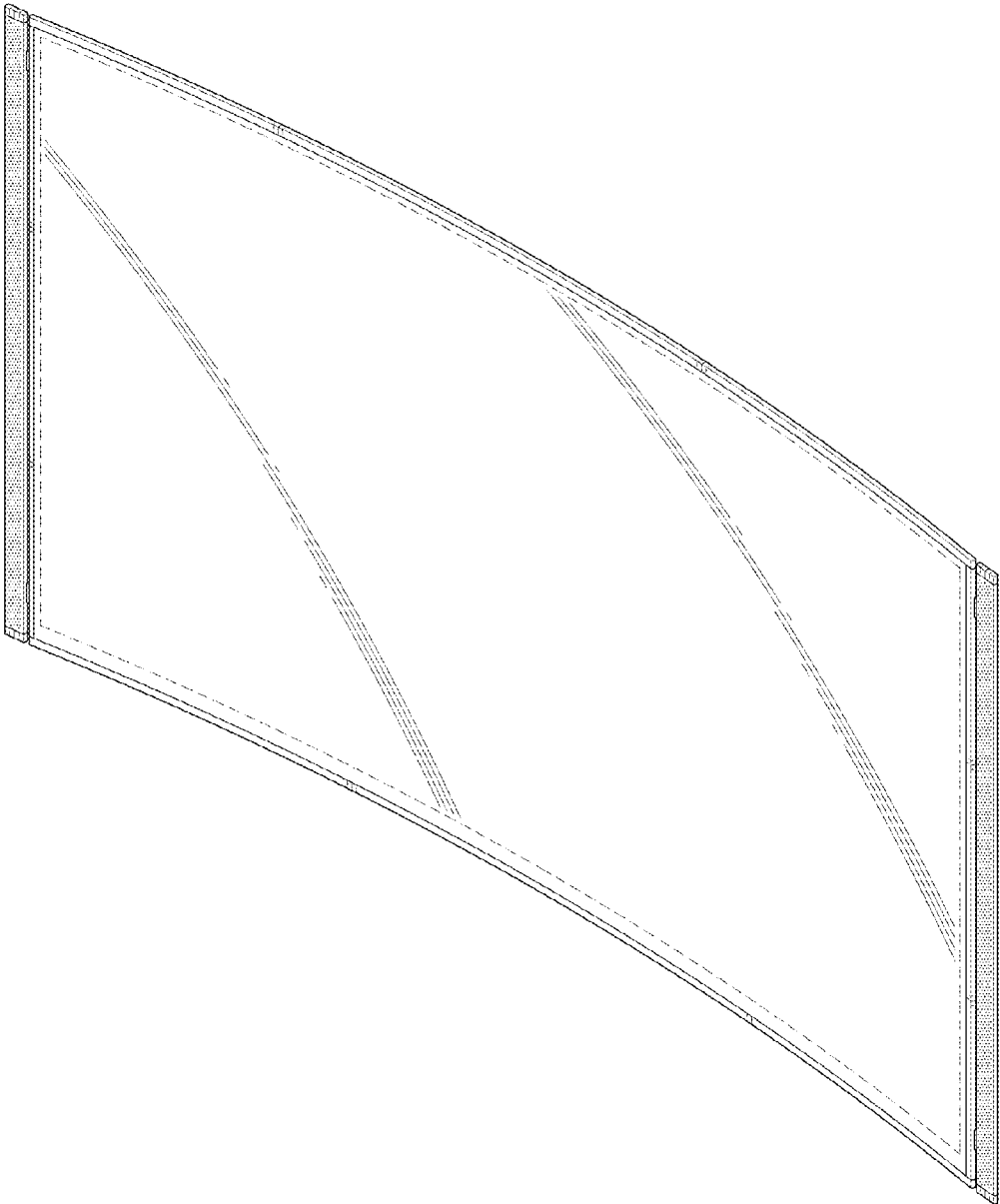

FIG. 15



FIG. 16

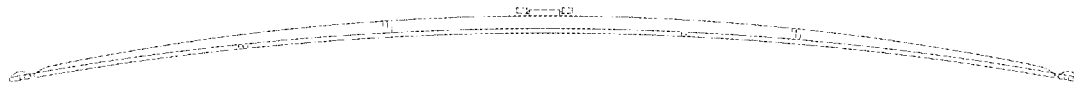

FIG. 17

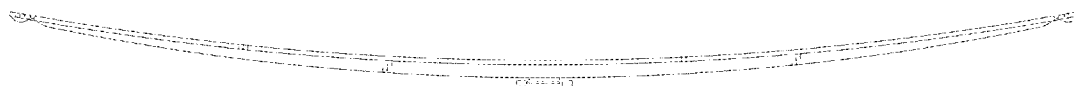

FIG. 18

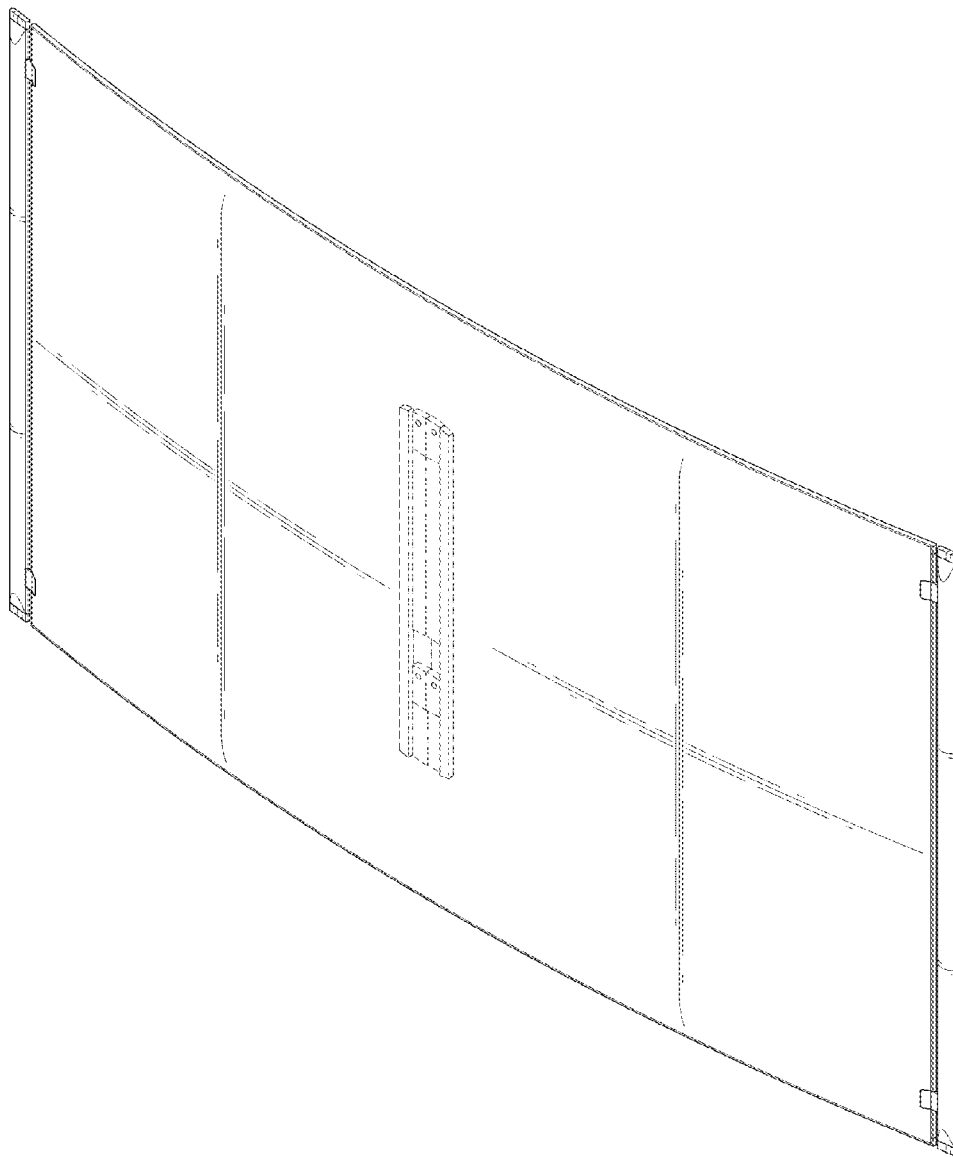

FIG. 19

