

(21) Application No: 2303511.6
 (22) Date of Filing: 12.10.2021
 Date Lodged: 10.03.2023
 (30) Priority Data:
 (31) 202004960 (32) 12.08.2020 (33) ZA
 (86) International Application Data:
 PCT/NZ2021/050176 En 12.10.2021
 (87) International Publication Data:
 WO2022/035329 En 17.02.2022

(51) INT CL:
 A61M 16/08 (2006.01) A61M 16/12 (2006.01)
 A61M 16/20 (2006.01)
 (56) Documents Cited:
 WO 2018/097469 A2 WO 2015/110098 A1
 US 20190091425 A1 US 20170095631 A1
 US 20160339202 A1
 (58) Field of Search:
 INT CL A61M
 Other: Google Patents, Espacenet

(71) Applicant(s):
Fisher & Paykel Healthcare Limited
15 Maurice Paykel Place, East Tamaki, 2013 Auckland,
New Zealand (including the Cook Islands,
Niue and Tokelau)
 (72) Inventor(s):
David John Love
 (74) Agent and/or Address for Service:
Forresters IP LLP
Port of Liverpool Building, Pier Head, LIVERPOOL,
L3 1AF, United Kingdom

(54) Title of the Invention: **Positive pressure breathing circuit**
 Abstract Title: **Positive pressure breathing circuit**

(57) The disclosure relates to a positive pressure breathing circuit and a method for ventilating a patient. The breathing circuit can be used in any type of pressurized breathing therapy including, for example, continuous positive air(way) pressure (CPAP) therapy and bilevel positive air pressure therapy where the inspiratory and expiratory pressures differ. The positive pressure breathing circuit comprises an inspiratory member including a distal portion connectable to a first gas and a proximal portion connectable to second gas wherein the inspiratory member is configured to store a volume of second gas. The inspiratory member further comprises a first non-return valve located proximally to the second gas entering the inspiratory member to inhibit the exhaled gases from entering the inspiratory member. The breathing circuit also comprises an expiratory member and second non-return valve to inhibit exhaled gases from re-entering the patient interface.

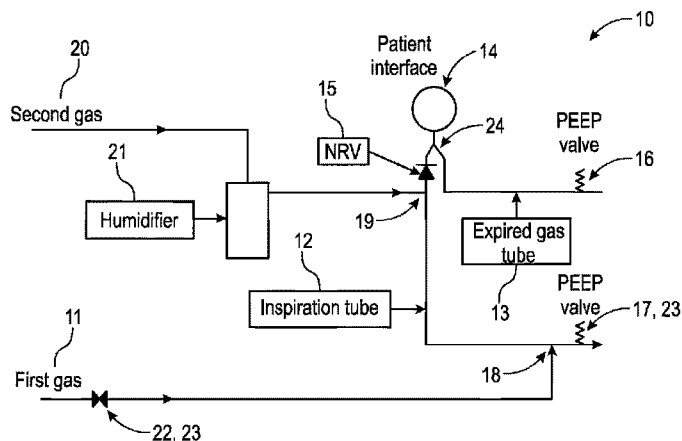

FIG. 1