

A. L. DEWEY.
Steam Engines.

No. 116,031.

Patented June 20, 1871.

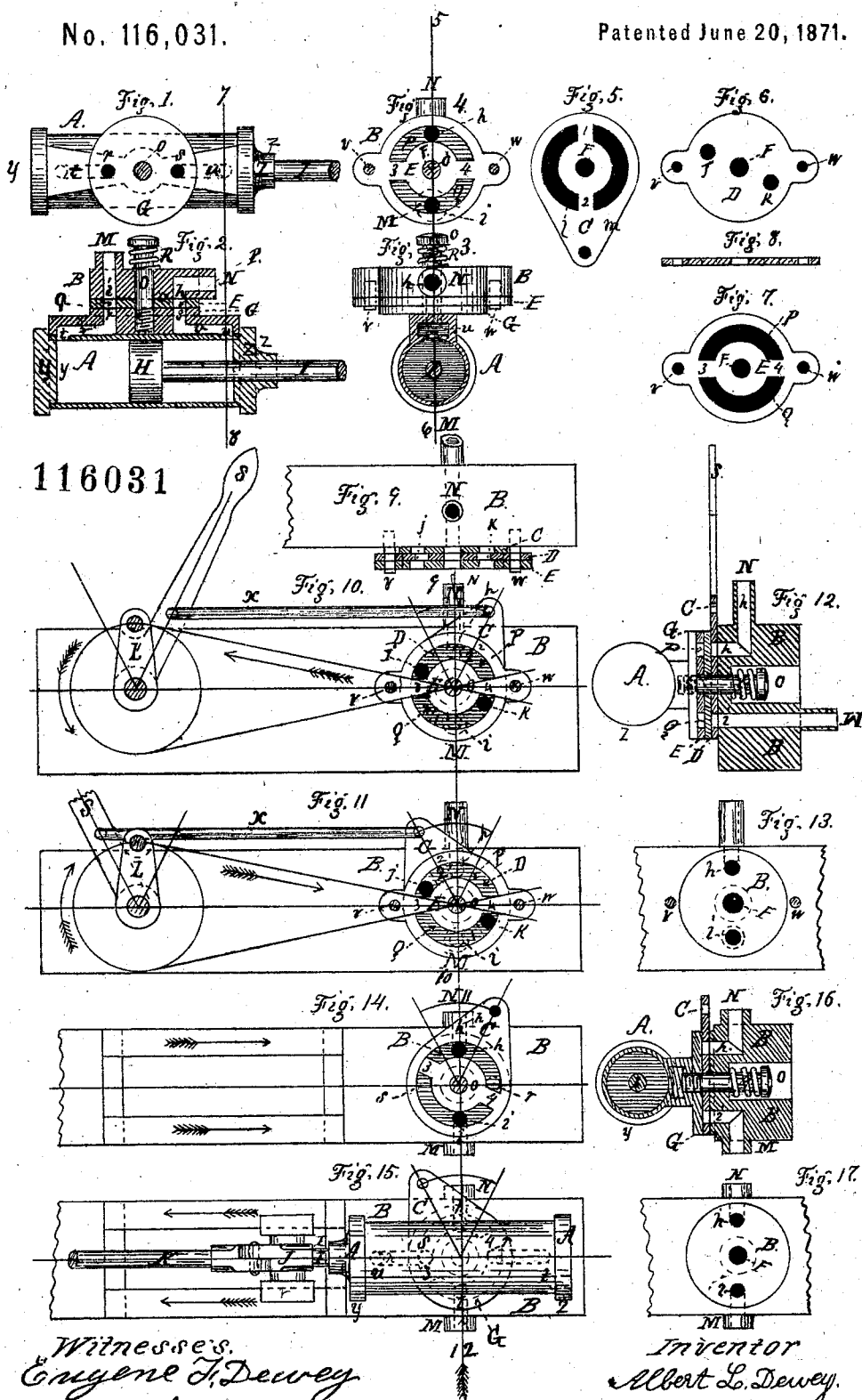

116031

Witnesses:
Eugene J. Dewey
Deputy Agent

Inventor
Albert L. Dewey.

UNITED STATES PATENT OFFICE.

ALBERT L. DEWEY, OF WESTFIELD, MASSACHUSETTS.

IMPROVEMENT IN STEAM-ENGINES.

Specification forming part of Letters Patent No. 116,031, dated June 20, 1871.

To all whom it may concern:

Be it known that I, ALBERT L. DEWEY, of Westfield, in the county of Hampden and State of Massachusetts, have invented certain Improvements in Steam-Engines, of which the following is a specification:

Nature and Objects of the Invention.

The first part of my invention relates to peculiar details of construction and arrangement of the parts composing the steam-chest, and a series of steam-passages, ports, valves, and valve-faces of a steam-engine cylinder; the object of this part of my invention being to cheapen and simplify its details and construction and also to extend its range of action. The second part of my invention relates to the combination, with the steam-chest and its valve-face, of a duplicate port-face and steam-valve with its connections; the object of this part of my invention being to reverse the direction of the steam in the cylinder, and thereby reversing the revolutions of the engine-shaft while running, and also to simplify the mechanism for actuating the reverse-valve.

The novel details of construction and arrangement will be described in connection with the accompanying drawing, which represents a steam-cylinder embodying my improvements.

Description of the Accompanying Drawing.

Figure 1 is a plan view of a cylinder with the steam-chest and valves removed, showing the port-face and steam-ports to the same. Fig. 2 is a vertical section of the cylinder, showing the steam-chest and valve-face replaced, taken in the line 5 6, Fig. 3. Fig. 3 is a transverse section of the same taken in the line 7 8, Fig. 2. Fig. 4 is a detached view of the steam-chest, showing the induction and eduction ports to the same, together with its valve-face. Fig. 5 is a detached view of the valve, showing its peculiar construction. Fig. 6 is a detached view of a duplicate port-face, showing the circular steam-ports to the same. Fig. 7 is a detached view of the valve-face E, (to the steam-chest B,) showing its two semicircular steam-passages to the same. Fig. 8 is a sectional elevation of Figs. 5, 6, and 7. Fig. 9 is a plan view of my invention with the steam-cylinder removed, showing the arrangement of the

valves, seats, ports, steam-passages, and steam-chest. Figs. 10 and 11 are side elevations of the same, showing the application of my improvements to an oscillating-cylinder engine, in connection with mechanism for reversing steam in the same. Fig. 12 is a transverse section of the same taken in the line 9 10, Figs. 10 and 11. Fig. 13 is a detached face view of the steam-chest to the same. Fig. 14 is a plan view, showing a modification of my invention when used as a stationary-cylinder engine, with the cylinder A removed. Fig. 15 is also a plan view of the same with the cylinder A replaced, and showing the valve C in a reverse position to that in Fig. 14. Fig. 16 is a transverse section of the same taken in the line 11 and 12 of Figs. 14 and 15. Fig. 17 is a detached face view of its steam-chest.

Similar letters and figures of reference indicate corresponding parts.

General Description.

A represents a steam-cylinder. B is a steam-chest to the same. C represents a valve to the same. D is the port-face to valve C, Fig. 5. E represents the valve-face of the steam-chest B. F represents circular openings in the steam-chest B, and pieces C, D, and E for the passage of the trunnion O of the steam-cylinder A. G is the port-face of the steam-cylinder A. H is the piston-head. I is the piston-rod. J is the cross-head. K is the connecting-rod. L is the crank. M is the induction-pipe. N is the eduction-pipe. O is the solid trunnion of the steam-cylinder A. P is the upper semicircular exhaust steam-chamber. Q is the lower semicircular live-steam chamber of face E. S is the hand or reverse-lever. *v* and *w* are two dowel-pins projecting from the steam-chest for the purpose of holding the valve-faces stationary. *h* is the exhaust-steam port of the steam-chest B. *i* is the live-steam port of the same. *j k* are the steam-ports to port-face D. *r s* are the steam-ports of the steam-cylinder A. *t u* are the ordinary steam-passages to the same. *x* is the valve-rod. *y* and *z* are the cylinder-heads. 1 2 3 4 represent the partitions which separate the two semicircular steam-chambers *l m*, Fig. 5, and P Q, Fig. 7.

This invention may be used upon a stationary, oscillating, or revolving cylinder,

The construction of my invention is as follows: The cylinder A has a solid trunnion, represented by the screw O in the drawing, and passing through the valves, valve-faces, and steam-chest. It is also provided with a circular projection or disk, G, cast upon and forming one piece with the casting containing the ordinary steam-passages *r s t u* of the cylinder A, and having its center in common with the screw or trunnion O, and having a diameter somewhat less than the length of the cylinder, but of sufficient width to allow of ports *r s* through it of a proper size for the admission and exit of steam, and with a sufficient surface in addition to prevent the escape of steam between it and its valve and steam-chest B, with which it forms one or more movable steam-tight joints. The valve-face E, valve C, together with the port-face D, with their steam-passages and ports, are made separate from the cylinder A. They are formed in cast-iron, or, in certain cases, they are punched out of thin sheet metal. The pieces C and E each contain two semicircular steam-passages or chambers, *l m*, Fig. 5, and P Q, Fig. 7, said passages being separated by narrow partitions, marked 1 2 3 4 in the drawing. The piece D contains only two small circular steam-ports, *j k*, said piece D being a duplicate of the port-face G of the cylinder A and of the steam-chest B. Said piece D is placed between the valve C and valve-face E, and serves to separate and cover the open semicircular steam-passages *l m* and P Q of Figs. 5 and 7, and at the same time allowing of steam communication between them through its steam-ports *j k*, as shown at Figs. 10 and 11, for purposes hereafter to be described. The steam-chest B has two circular steam-ports, *h i*, upon its face similar to and corresponding with the ports *r s* of the steam-cylinder A, said ports *h* and *i* being placed, in certain cases, at right angles with the cylinder-ports *r s*, and communicating with the same through the steam-passages and ports contained in the valve C and faces D E. The three pieces E D C being placed between the steam-chest B and cylinder A, are all held together steam-tight by means of a single screw (representing the solid trunnion O) in connection with a spring, R, Figs. 2, 3, 12, and 16. The steam-chest is provided with two hubs or bosses, M N. The one marked M is for the live steam supplied to it from the boiler, and having an opening, *i*, from it through the face of the steam-chest directly into one of the semicircular steam-passages, marked Q, in the valve-face E, Figs. 4 and 7; the other one, N, is for the exhaust steam, and opens directly from the opposite semicircular steam-passages, marked P, of the valve-face E, through the steam-chest at N, and has the exhaust-pipe attached at this point. In certain cases the steam-chest B and valve-face E may be cast together in one piece, as at B E, Figs. 2, 3, and 4; also, in certain cases, where the cylinder is large, the valve-face E and port-face D may be cast in one and the same piece, as at D E, Figs.

9 and 12. The steam-chest B, together with its valve-faces E and D, may be fastened stationary with either the engine-frame or the steam-cylinder, or both, by means of the two dowel-pins *v w*, as circumstances may require it.

I will now describe the operation of my invention as applied in its simplest form to a direct-acting oscillating steam-engine, particular attention being had to Figs. 1, 2, 4, and 10 of the drawing. The action of the engine is as follows: Steam being admitted into the pipe M of the steam-chest, Figs. 1, 4, and 10, and the crank-pin L being turned up past the center, (the piston-head H being on its back stroke,) it will be seen that the oscillation of the cylinder will bring the port *r* in communication with the semicircular steam-passage Q in the steam-chest B E and admit steam to the cylinder between its back head *y* and the piston H, forcing the piston to the front end of the cylinder and bringing the crank-pin L to its back dead-center and the cylinder again to its horizontal position, the piston having completed its outward stroke. The momentum of the balance-wheel then carries the crank-pin downward past the center and causes the cylinder to oscillate in the opposite direction, bringing the port *s* in communication with the semicircular steam-chamber Q, and admitting steam to the cylinder between the front head Z and the piston H, and forcing it backward again to its first position, and completing a revolution in the direction of the arrow in Fig. 10. While the port *r* is in communication with the lower steam-passage Q, admitting live steam to the front end of the cylinder, the port *s* is in communication with the upper opening or exhaust-passage P, allowing the exhaust steam to escape freely into it from before the piston.

When the port *s* is in communication with the lower steam-passage Q, admitting the live steam to the front end of the cylinder, the port *r* is in communication with the upper opening P of the exhaust-chamber, allowing the exhaust steam to escape freely from the back side of the piston.

It may be seen, by reference to Figs. 1, 2, 3, and 4, that the same construction of the steam-cylinder A, steam-chest B, and valve-face E will allow the cylinder to make a complete revolution, and take and exhaust its steam as before (at each revolution of the cylinder) by having its piston-rod attached to suitable connections for causing the cylinder A to revolve while its steam-chest B remains stationary, and thus apply equally as well for a rotary cylinder as for an oscillating one. It may also be seen that by causing the cylinder A, Fig. 15, to remain in a fixed position, and attaching an arm, C, to the valve-face E, (at right angles with its partitions 3 and 4, Fig. 14,) and causing the same to oscillate by means of suitable connections, it will act as a valve, and transpose the live and exhaust steam passages from one end, *r*, to the other end, *s*, of the cylinder A, and enable it to take and exhaust its steam as before, and cause the reciprocating motion

of the piston of a stationary-cylinder engine, as shown in Figs. 1, 2, 14, 15, 16, and 17.

The above description constitutes one of the features of my invention.

Should the engine be required to run in the opposite direction, it is only necessary to transpose the steam and exhaust-passages, making the upper one, marked P, the steam, and the lower one, Q, the exhaust-passage, which, of course, may be done by making the pipe N the induction and the pipe M the eduction. But when the engine is required to be reversed when running this mode of transposing the eduction and induction pipes is not practical; therefore, to accomplish the desired result, I allow the steam-pipes M and N to remain undisturbed, and reverse the steam between the steam-chest B and cylinder A by means of a valve, C, Fig. 5, and port-face D, Fig. 7, placed between the steam-chest B and valve-face E. The valve C is a duplicate of the valve-face E, with an arm, C, attached, as shown in the detached view, Fig. 5. The port-face D is also a duplicate of the port-face of either the steam-chest B or steam-cylinder A, said port-face D having the line of its steam-ports *j k* somewhat inclined from a horizontal line, as shown at Figs. 6, 10, and 11, one of the ports, *k*, opening into the lower semicircular steam-passage Q of the valve-face E, while the other port, *j*, opens into the upper chamber P of the same. The port-face D and valve-face E are held stationary with the steam-chest B by means of dowel-pins *v w*, Figs. 9, 10, and 11, while the valve C is left at liberty to oscillate upon trunnion O of the cylinder A by means of the connection *x* and reverse or hand-lever *s*, Figs. 10 and 11.

The valve C, Fig. 5, has its partitions 1 and 2, which separate the semicircular steam-passages *l m*, placed at right angles to those marked 3 and 4 of valve-face E, in which position they correspond with the line of the induction and eduction ports *h i* of the steam-chest B and cover the same, thereby entirely shutting off the steam communication between the steam-chest B and cylinder A. The order and arrangement of valves and faces are shown in section at Figs. 9 and 12, the valves and faces encircling the trunnion O like washers between the steam-chest and cylinder. The office of valve C, Fig. 5, is to direct the live steam into either the upper or lower semicircular steam-passages P and Q, thereby transposing the same into either the induction or eduction chamber, as occasion may require, and by this means reversing the revolutions of the engine. The revolutions of the engine are reversed when running by throwing the hand-lever 3 with its attached valve C over upon their opposite angles, as shown in Fig. 11.

I claim—

1. The construction and arrangement of the steam-chest B with its steam-passage P Q, in combination with the steam-cylinder A, substantially as and for the purpose hereinbefore set forth.

2. The combination, with the steam-chest B and valve-face E, of the port-face D and steam-valve C, with its connections *s x*, substantially as and for the purpose hereinbefore set forth.

ALBERT L. DEWEY.

Witnesses:

EUGENE F. DEWEY,
DEXTER AVERY.