

- [54] **COMBINED DOOR OPENER AND ESCUTCHEON UNIT**
- [75] Inventor: **Leo F. Wildgen**, Minneapolis, Minn.
- [73] Assignee: **Ideal Security Hardware Corporation**, St. Paul, Minn.
- [**] Term: **14 Years**
- [21] Appl. No.: **456,516**
- [22] Filed: **Jan. 7, 1983**
- [52] U.S. Cl. **D8/301; D8/302; D8/308; D8/310; D8/311; D8/353**
- [58] **Field of Search** **D8/300, 301, 302, 310, D8/307, 308, 311, 353; 16/110 R, 111 R, 118, 121, 127; 292/148, 336.3, 347, DIG. 68**

[56] **References Cited**

U.S. PATENT DOCUMENTS

D. 48,362	1/1916	Bosworth	D8/310
D. 80,619	3/1930	Graff	D8/308
D. 199,922	12/1964	Schlage	D8/310
D. 204,089	3/1966	Adler	D8/308
D. 225,204	11/1972	Kendrick	D8/311
D. 261,856	11/1981	Meisner	D8/300
3,107,113	10/1963	Sconzo	D8/302

OTHER PUBLICATIONS

Barrows Locks and Hardware Cat. 38; ©1939, p. 78; Oxford Lockset, D150024 ×15103.

Primary Examiner—B. J. Bullock
Attorney, Agent, or Firm—Merchant, Gould, Smith, Edell, Welter & Schmidt

[57] **CLAIM**

The ornamental design for a combined door opener and escutcheon unit, as shown and described.

DESCRIPTION

FIG. 1 is a reduced front perspective view of the outer elements of the combined door opener and escutcheon unit showing my new design, shown separately for clarity of illustration and the broken line showing of a portion of a door being for illustrative purposes only; FIG. 2 is a front elevational view thereof; FIG. 3 is a top plan view thereof; FIG. 4 is a bottom plan view thereof; FIG. 5 is a right side elevational view thereof; FIG. 6 is a left side elevational view thereof; and FIG. 7 is a front elevational view of the inner elements, again shown separately for clarity of illustration. The rear surfaces of the individual elements are unornamented.

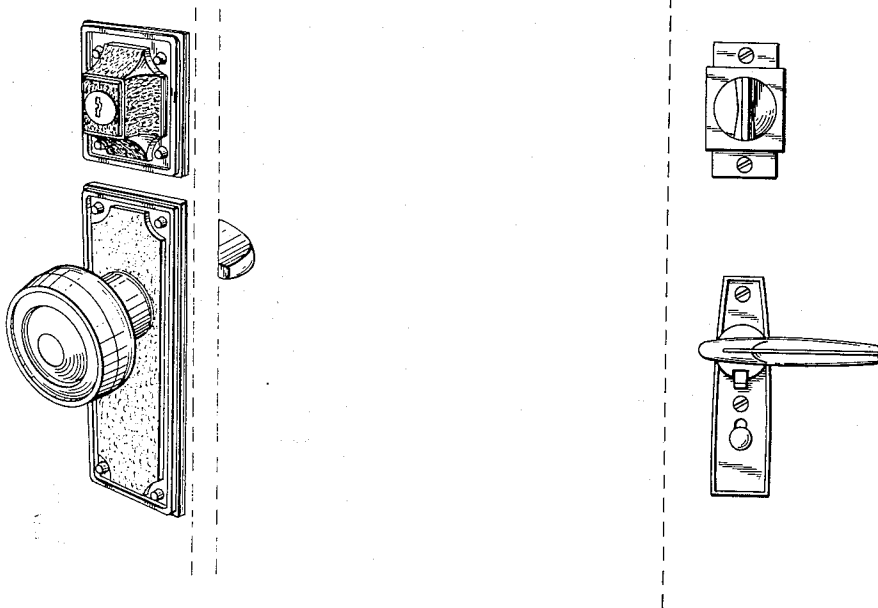

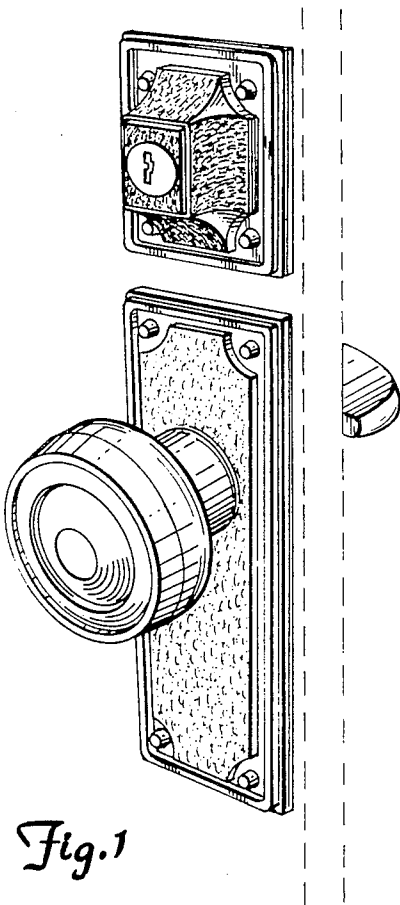

Fig. 1

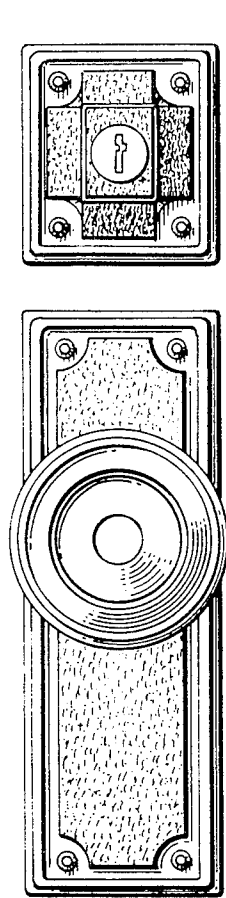

Fig. 2

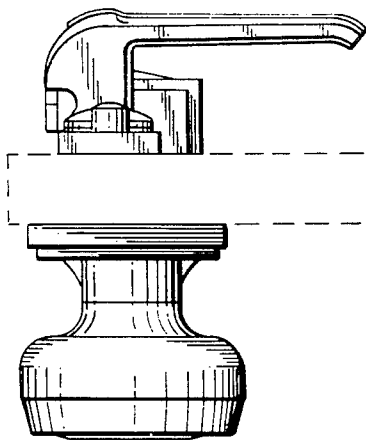

Fig. 4

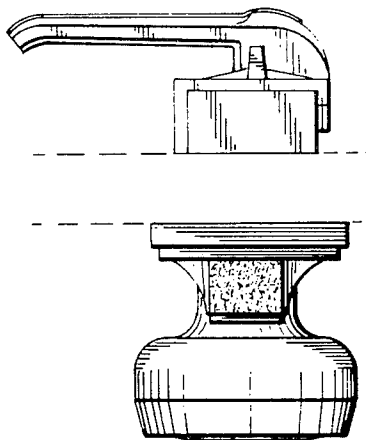

Fig. 3

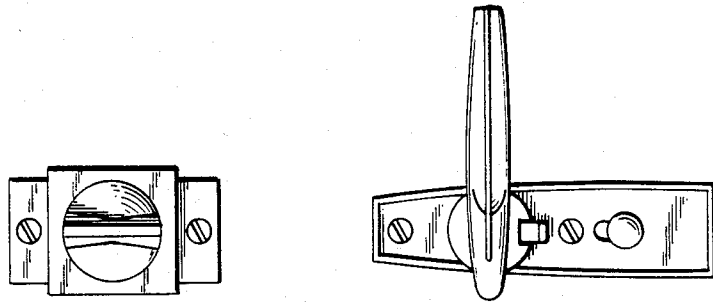

Fig. 7

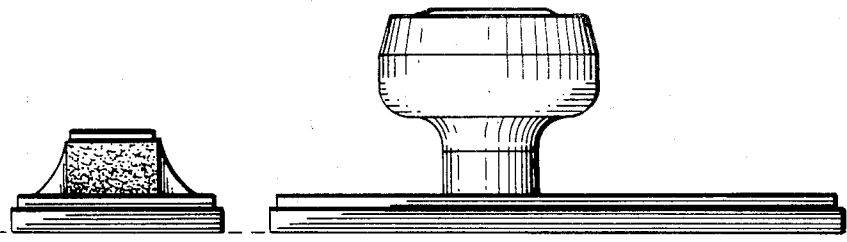

Fig. 6

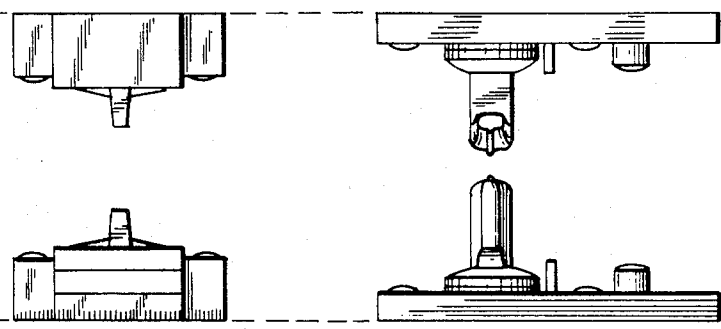

Fig. 5

