



## INTERNATIONAL APPLICATION PUBLISHED UNDER THE PATENT COOPERATION TREATY (PCT)

(51) International Patent Classification <sup>5</sup> : <b>A61B 17/00</b>	<b>A1</b>	(11) International Publication Number: <b>WO 95/09567</b> (43) International Publication Date: 13 April 1995 (13.04.95)
<p>(21) International Application Number: PCT/US94/11208</p> <p>(22) International Filing Date: 3 October 1994 (03.10.94)</p> <p>(30) Priority Data: 08/131,203 1 October 1993 (01.10.93) US</p> <p>(71) Applicant: BOSTON SCIENTIFIC CORPORATION [US/US]; 480 Pleasant Street, Watertown, MA 02172 (US).</p> <p>(72) Inventors: KIM, Hannah, S.; 128 Brattle Lane, No. 1, Arlington, MA 02174 (US). SANDOCK, David, L.; 1 Foss Place, Littleton, MA 01460 (US). NOTT, Sepideh, H.; 1170 Wilson Road, No. 17, Fall River, MA 02720 (US).</p> <p>(74) Agent: WILLIAMS, John, N.; Fish &amp; Richardson, 225 Franklin Street, Boston, MA 02110 (US).</p>	<p>(81) Designated States: CA, JP, European patent (AT, BE, CH, DE, DK, ES, FR, GB, GR, IE, IT, LU, MC, NL, PT, SE).</p> <p><b>Published</b> <i>With international search report. Before the expiration of the time limit for amending the claims and to be republished in the event of the receipt of amendments.</i></p>	

(54) Title: IMPROVED VENA CAVA FILTER

## (57) Abstract

A vascular filter (10) comprises an emboli-capturing portion having a set of helical filter-wires (30) joined at a central region and extending in a given direction along the blood vessels (42) in a diverging relationship to the axis constructed to engage the walls of said vessel. A major mid-portion of the length of the free ended wires are of generally helical form, cooperatively related to form an effective emboli capturing array (26). Anchoring is accomplished by a separate assembly formed of struts (40) and anchoring devices (38). A parallelogram supporting strut assembly and other means for providing linear engagement with the wall of the vena cava are shown. The parallelogram structure is shown to have filter capability by itself as well.

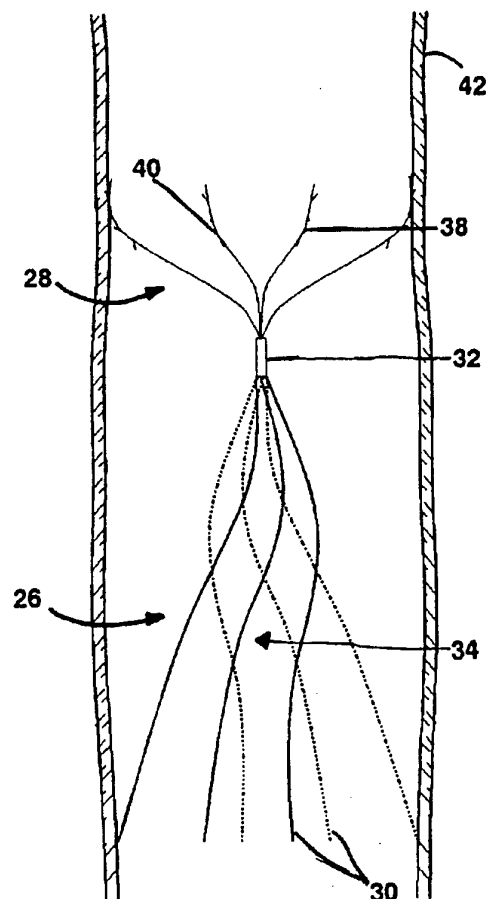

**FOR THE PURPOSES OF INFORMATION ONLY**

Codes used to identify States party to the PCT on the front pages of pamphlets publishing international applications under the PCT.

AT	Austria	GB	United Kingdom	MR	Mauritania
AU	Australia	GE	Georgia	MW	Malawi
BB	Barbados	GN	Guinea	NE	Niger
BE	Belgium	GR	Greece	NL	Netherlands
BF	Burkina Faso	HU	Hungary	NO	Norway
BG	Bulgaria	IE	Ireland	NZ	New Zealand
BJ	Benin	IT	Italy	PL	Poland
BR	Brazil	JP	Japan	PT	Portugal
BY	Belarus	KE	Kenya	RO	Romania
CA	Canada	KG	Kyrgyzstan	RU	Russian Federation
CF	Central African Republic	KP	Democratic People's Republic of Korea	SD	Sudan
CG	Congo	KR	Republic of Korea	SE	Sweden
CH	Switzerland	KZ	Kazakhstan	SI	Slovenia
CI	Côte d'Ivoire	LI	Liechtenstein	SK	Slovakia
CM	Cameroon	LV	Latvia	SN	Senegal
CN	China	LU	Luxembourg	TD	Chad
CS	Czechoslovakia	LV	Latvia	TG	Togo
CZ	Czech Republic	MC	Monaco	TJ	Tajikistan
DE	Germany	MD	Republic of Moldova	TT	Trinidad and Tobago
DK	Denmark	MG	Madagascar	UA	Ukraine
ES	Spain	ML	Mali	US	United States of America
FI	Finland	MN	Mongolia	UZ	Uzbekistan
FR	France			VN	Viet Nam
GA	Gabon				

- 1 -

IMPROVED VENA CAVA FILTER

This invention relates to blood filters, and more particularly to filters designed to be implanted in a human vena cava and the like.

Background of the Invention

Vena cava filters are designed to capture emboli and prevent them from migrating via the blood stream into the pulmonary arteries. A vena cava filter is typically placed via a catheter inserted through a puncture in a vein. For insertion, the filter is collapsed within the catheter and is released after the catheter has accessed the vena cava.

Known vena cava filters in collapsed form have required relatively large diameter catheters and correspondingly large puncture openings which has limited the access point generally to the largest veins, i.e. the femoral and jugular veins. The relatively large puncture wound has at times produced complications.

Summary of the Invention

The present invention provides filters of small collapsed construction that are self-centering in the human vena cava over the considerable range of diameters of vena cava that exist. The invention also provides a high degree of consistency and repeatability in placement of the filter and secure anchoring of the filter to the vein wall to ensure no movement, particularly during the acute phase, until tissue growth over the anchors occurs to make the filter more secure.

The invention has various aspects which individually contribute improvement, and which, in select combinations, enable a smaller collapsed form and improved performance to be achieved.

- 2 -

Specifically, in one important respect, a vena cava filter is provided which, by separation of the filtering and anchoring functions into two or more sets of legs or struts, enables small diameter collapse of each set, in a construction which is desirably short and in which the axially spaced wall contact of the sets achieves self-centering over a wide range of vena cava sizes. Secure anchoring is also achieved at a precise location against movement in either direction as a result of firm engagement of the anchoring devices.

According to one principle of the invention a set of filter-wires is provided, which is to achieve the clot capturing function, capable of deploying over a wide range of cone angles dependent upon the size of the vena cava. These filter-wires extend generally upstream from a central region of connection, to wall-engaging free ends. The filter-wires of the set desirably have a general helical matching configuration that presents an effective clot-capturing aspect, in a construction that is readily collapsible into a small compass. From the axis also extends a collapsible strut structure which supports wall-engaging anchors or projections that securely engage the vessel wall at a location or locations spaced axially from the region of contact of the free ends of the filter-wires. Because nearly all of the filtering action is accomplished by the set of helical filter-wires, the design of the strut structure need not deal with its filtering aspect. While other cross-sections are operable in certain circumstances, the struts are preferably of rectangular transverse cross-section, i.e. of strip form, the long dimension of this cross-section arranged circumferentially, and the struts extend at, effectively, a steeper angle relative to the longitudinal axis than do filter-wires. This steepness favorably affects their force-applying capability at the

- 3 -

vena cava wall. Other strut cross-sections including oval and even circular can, however, be employed under certain circumstances.

The strut structures in certain preferred  
5 embodiments diverge to their wall-contacting points in the opposite axial direction to that of the filter-wires in order to achieve the self-centering effect. Because of the strip-form construction they can readily support multiple anchors or projections along their respective  
10 lengths in the outer regions to provide firm anchoring capability in both small and large vena cava. In another preferred form, the strut structure extends in the same axial direction as does the filter wire structure, but at a steeper effective angle to achieve firm anchoring at a  
15 location spaced axially from the wall contact region of the filter-wires. Again this structure achieves a secure self-centering function over a wide range of vena cava sizes. The self-centering performance of preferred embodiments is assisted by employment of linear axially  
20 parallel wall-engaging elements supported by the strut structure. These are particularly beneficial in embodiments in which the strut structure diverges in the same direction as the filter-wires, but also have applications in a "ski-like" single support point  
25 configuration in which the strut structure diverges in the opposite direction from that of the set of filter-wires.

A parallelogram-like strut support of opposite ends of linear wall-engaging elements is an important  
30 feature in certain preferred embodiments. It enables the linear wall elements to maintain their parallel relationship to the axis of the filter, thus centering the filter over a range of sizes. This novel parallelogram support, while contributing significantly  
35 to the performance capability in combination with one of

- 4 -

more sets of helical filter-wires, also has merit in its own right in which the support struts are constructed and arranged themselves to have a filtering function, or in which such strut structure is combined with other  
5 filtering arrays.

While presently preferred to be constructed of elastic metals such as nickel titanium alloy operating in the linear portion of the stress/strain curve, other materials can be used to advantage. Other materials of  
10 metallic or polymeric nature, including super-elastic metal, shape memory metal, and newly developing materials, may be used to advantage. Surface treatments of the filter-wires and supports can contribute to their effectiveness. Following the concepts provided herein,  
15 it becomes possible to form vena cava filters sufficiently small that in certain cases they may be introduced less invasively through smaller veins when access to the femoral or jugular vein is not possible.

These and other objects and features of the  
20 invention will be understood from the following summary of certain specific features of the invention and from the detailed description of presently preferred embodiments in connection with the drawings.

According to one aspect of the invention, there is  
25 provided a vascular filter for placement in a blood vessel for preventing the movement of emboli in the blood stream of a human. The filter includes a set of filter-wires that diverge from a central region in a given direction along the blood vessel forming an emboli-  
30 capturing array, the filter-wires having portions that engage the vessel wall, and an anchoring assembly defined by at least one set of struts joined centrally with said set of filter-wires. Portions of the anchoring assembly are constructed and arranged to engage the wall of the  
35 blood vessel in a manner anchoring the filter in

- 5 -

position, the region of the anchoring being spaced from the region of contact of the set of filter wires with said vessel wall.

In preferred embodiments, the anchoring assembly includes anchoring formations supported by the struts and disposed for engagement with the walls of the blood vessel, each of the formations comprising at least one pointed projection to engage wall tissue and anchor the strut thereto.

10 In certain preferred embodiments each anchoring formation comprises at least a pair of pointed projections, the projections of the pair being oriented in opposite directions along the blood vessel, each being angled to penetrate wall tissue, the pair being effective  
15 in resisting dislodgement of the strut in either direction along the vessel. Also, in preferred embodiments the wall-engaging formations supported by the struts are constructed and arranged to maintain generally linear contact with the vessel walls.

20 In preferred embodiments of this aspect of the invention the filter-wires of the set are helically configured and arranged to form an effective clot-capturing array that can be radially expanded and contracted to adapt to vessels of different sizes.

25 According to another aspect of the invention, there is provided a vascular filter for placement in blood vessels for preventing the movement of emboli in the blood stream of a human, the filter comprising an emboli-capturing portion having a set of filter-wires  
30 joined at a central region and extending in a given direction along the blood vessel, and terminating in free ends constructed to engage the wall of the vessel, the wires having a diverging relationship to the axis of the filter. The filter features at least a major mid-portion  
35 of the length of the free ended wires of the set being of

- 6 -

generally helical form, cooperatively related to form an effective emboli-capturing array.

Preferred embodiments of these aspects of the invention have one or more of the following features.

5           The filter-wires have substantially less transverse cross-section and are collapsible into a small size bundle. The filter wires are comprised of elastic metal of round cross-section, their helical extent being curved at a radius of the order of 1/4 inch to 1/2 inch  
10 and the struts are comprised of flat strip-form material arranged with the direction of thickness of the strip oriented radially.

          The filter wires are comprised of elastic material, the wires being cooperatively related, upon  
15 compaction, to elastically straighten and to meet closely with each other, enabling into a small size, and enabling radial compaction of the set into an introducer catheter of about 9 French or less outer diameter for insertion into a blood vessel. The wires when released from the  
20 catheter into the blood vessel are constructed to expand to form the effective emboli-capturing array.

          The filter is constructed for placement in blood vessels over a range of sizes, portions of the filter-wires adjacent the free ends being relatively straight,  
25 enabling, substantially end-contact of the wires with the walls of the blood vessel over the range of vessel sizes.

          Preferably, all of the filter-wires are curved in the same general helical direction. Alternatively, the wires of the set of filter-wires may comprise multiple  
30 subsets, the wires of one set being curved in the opposite helical direction from the helical direction of curvature of wires of another subset.

          For anchoring the filter, an anchoring assembly provides anchoring formations distributed about the  
35 filter. The anchoring formations are provided with



- 7 -

parallelogram-like supports arranged to adapt to the walls of vessels over a range of sizes while maintaining substantially the same attitude with respect to the walls of the vessel. Preferably the parallelogram-like supports  
5 are constructed and arranged to expand from a collapsed condition without change in the overall length of the filter.

In certain preferred embodiments of above mentioned aspects of the invention the struts diverge  
10 from the central region in a direction opposite to the direction of divergence of the filter-wires, the struts terminating in portions that engage the wall of the blood vessel, with the spacing of the regions of contact of the filter-wires and struts with the vascular wall being  
15 selected to stabilize the filter in the vessel in a generally centered relationship. In such embodiments, preferably the wall-engaging formations supported by the struts are constructed and arranged to maintain generally linear contact with the vessel walls, preferably the  
20 wall-engaging formations being linear elements each supported in its mid-region by a strut of the set.

In other preferred embodiments, the struts are short relative to the filter-wires and diverge in the same direction as the filter-wires, but at a greater  
25 angle relative to the longitudinal axis of the filter. The spacing of the regions of contact of the filter-wires and struts with the vascular wall are selected to stabilize the filter in the vessel in a generally centered relationship.

30 In such embodiments, preferably the outer, wall-engaging formations supported by the struts are constructed and arranged to maintain generally linear contact with the vessel walls, the wall-engaging formations being linear elements each supported in its  
35 mid-region by a strut of the set.

- 8 -

In preferred embodiments, wall-engaging formations are linear elements, the linear elements being supported at one end by a strut of the set, and the other end of each of the linear elements is joined to and supported by a respective strut of a second set of struts of the assembly, each of the linear elements comprising an integral extension of at least one of the respective supporting struts. Preferably, the struts of the second set are centrally joined to each other at a location spaced axially from the region at which the struts of first set are joined, providing effectively parallelogram-like support to the linear wall-engaging elements to assure substantially linear contact with the vessel wall over a range of sizes of the vessel.

In other preferred embodiments, the struts have free end portions constructed to engage the wall of the vessel, there being a plurality of anchoring formations on the strut. The formations are arranged so that one formation is relatively more effective for anchoring in walls of blood vessels of relatively large size and the other formation is relatively more effective for anchoring in walls of smaller size vessels.

Preferably, the anchoring formations comprise at least one pointed projection. In certain preferred embodiments, each anchoring formation comprises at least a pair of pointed projections, the projections of the pair being oriented in opposite directions along the blood vessel, each being angled to penetrate wall tissue and effective in resisting dislodgement of the strut in either direction along the vessel.

In certain embodiments, preferably the filter wires are of round cross-section and the struts are of rectangular transverse cross-section, the thin dimension of the strut cross-section being arranged in the radial direction.

- 9 -

In certain embodiments, preferably a surface treatment is included on the struts and/or wires that enhances their effectiveness. In certain embodiments the treatment is a biocompatible polymeric coating and in  
5 other embodiments it is a metal coating.

In one particular aspect of the invention there is provided a vascular filter for placement in blood vessels for preventing the movement of emboli in the blood stream of a human, the filter including an anchoring assembly  
10 comprising anchoring formations distributed about the filter and mounted on parallelogram-like supports arranged to adapt to the walls of vessels over a range of sizes.

Preferred embodiments of this aspect of the  
15 invention may have the following features.

The parallelogram supports themselves form at least part of an emboli-capturing array. The outer wall-engaging elements are constructed and arranged to make generally linear contact with the vessel wall, one end of  
20 each of the wall-engaging elements being joined to and supported by a strut of a first set of struts, and the other end of each of the wall-engaging elements being joined to and supported by a respective strut of a second set of struts. The second set of struts are centrally  
25 joined to each other at a location spaced axially from the region at which the first set of struts are joined, providing effectively parallelogram-like support to the outer, linear wall-engaging elements. Preferably each of the linear wall-engaging elements comprises an integral  
30 extension of at least one on the respective supporting struts.

#### Brief Description of Drawings

Fig. 1 is a front view, partially cut away, of a human with a preferred embodiment of the invention in  
35 place. Figs. 2 - 8 are side views of respective

- 10 -

preferred embodiments of the invention implanted in vena  
cavae.

Figs. 2a - 8a are transverse views, respectively,  
looking in the direction of the longitudinal axis of the  
5 embodiments of Figs. 2 - 8.

Figs. 2b - 8b are side views, respectively of the  
embodiments of Figs. 2 - 8 implanted in vena cavae having  
smaller diameters than those shown in Figs. 2 - 8.

Figs. 2c - 8c are transverse views respectively  
10 looking in the direction of the longitudinal axis of the  
embodiments of Figs. 2b - 8b.

Figs. 9 and 9a show, for comparison, transverse  
views in the direction of flow of filters having helical  
and straight wires interacting with emboli 16 travelling  
15 in vena cavae.

Fig. 10 is a two-dimensional side view of a filter  
wire which has a straight end-portion and a curved  
portion.

Fig. 10a is an end view of the filter wire shown  
20 in Fig. 10.

Fig. 11 is a, front view of an end portion of a  
strut showing a preferred pointed projection design.

Fig. 12 is a side view of the pointed projection  
design of Fig. 11.

25 Figs. 13 and 14, 15 and 16, 17 and 18, 19 and 20,  
21 and 22, and 23 and 24 are pairs of views similar to  
Figs. 11 and 12, respectively illustrating alternative  
pointed projection embodiments.

#### Description of Presently Preferred Embodiments

30 As shown in Fig. 1, vena cava filter 10 is  
implanted in the inferior vena cava 12 of human 14, and  
is designed to capture emboli 16 formed in the leg veins  
18. If vena cava filter 10 is not implanted, emboli 16  
may be transported by blood flowing through the veins,

- 11 -

(arrows represent direction of blood flow) through heart 20, and into the pulmonary arteries 22. Because pulmonary arteries 22 have smaller diameters than vena cava 12, an embolus 16 may become lodged and restrict the blood flow to one of lungs 24. This may result in the body's oxygen supply being partially or wholly cut off and may possibly result in death.

Referring now generally to Figs. 2 - 7, vena cava filter 10 is comprised of emboli capturing portion 26 and anchoring portion 28. Emboli capturing portion 26 is comprised of a set of filter-wires 30 which are joined at common apex 32 and extend in a diverging manner in a given direction to conform to an imaginary cone surface 36 (shown as the dashed lines in figure 10).

Emboli capturing portion 26 is comprised of filter-wires 30 extending in a helical fashion to form spirals when viewed axially. This shape will cause an embolism to be channeled into central apex region 34 of the filter. Because the filter is placed concentrically in the vena cava, the filter will hold the trapped embolism near the center of the vena cava where the blood flows fastest. It is important to trap the embolism in a current of fast moving blood to allow the body's natural lysing process to efficiently dissolve the embolism.

Cross-sectional views of filters employed in different size vena cavae are shown in Figs. 2a - 8a and Figs. 2c - 8c. The apparent curvature of the filter-wires is greater in the smaller diameter case (Figs. 2c - 8c) because of compaction of the emboli capturing array.

Figs. 9 and 9a show that a helical filter-wire pattern (Fig. 9) provides a greater capturing aspect for emboli 16 travelling in the vena cava than does a straight wire arrangement (Fig. 9a). Thus, the spiral shape of the wires allows favorable interaction between

- 12 -

emboli and filter-wires, resulting in favorable emboli capture without significant impedance of blood flow.

At the same time, the helical shape of filter-wires 30 further facilitates implantation with small catheters because the curvature of the wires may be straightened to a great extent without causing the wire to undergo permanent deformation, thus enabling collapse of the structure into a small package for insertion.

It is presently preferred that filter-wires 30 all spiral in a single direction, as shown in Figs. 2, 4, 5, 6 and 7. Effective emboli-capturing array can be achieved with relatively few wires and the structures made of fine wires can be collapsed to fit inside a small introducer catheter, e.g. of 9 French outer diameter. Filters shown in Fig. 3, with filter-wires 30 spiraling in opposite directions may, however, be employed in certain circumstances.

In preferred embodiments the mid-portions of the individual filter-wires are helically curved while outer portions are less curved or even completely straight. The straight and curved portions of such an individual filter-wire 30 extending from apex 32 are shown in Figs. 10 and 10a. In the preferred embodiment, the initial portion of the filter-wire near the apex (shown as the initial segment of L1 in Fig. 10a) is also approximately straight. The mid-portion (the middle segment of L1) is curved with an approximate angle of 30 degs. relative to the longitudinal axis of the cone 36, and the outer end-portion (L2) is again straight. The straight outer end-portion prevents the outer tip of filter-wires 30 of an inserted device from bending inward toward the center of the vena cava and potentially impeding blood flow when the filter is inserted in very small lumens.

Adequate emboli capturability is achievable in single direction helical filters by using six filter-

- 13 -

wires, and in double spiral filters by using eight filter-wires. Filter-wires 30 are preferably formed from nickel titanium alloy, although titanium, titanium alloy, stainless steel, or any other biocompatible material with  
5 elasticity may in certain circumstances be employed to advantage. In the preferred cases of use of nickel titanium alloy, the wires are operating in the linear portion of the stress/strain curve of the alloy, though it is possible to employ wires operating in the super-  
10 elastic region while obtaining benefits of the invention. Likewise, thermally responsive shape-memory metal can be employed with the geometric and spatial constraints provided by the invention. It is also anticipated that new materials, as they are developed, will be useful.  
15 Coatings, such as biocompatible polymeric coatings, and surface treatments, such as metallization with a noble metal can be applied to the wires and struts to advantage.

We have found that the diameter of the helical  
20 wires can be determined by two considerations: the wires must be stiff enough to retain the generally, helical and conical shape, and must be small enough to collapse to fit within the desirably small introduction catheter. The presently preferred filter-wire diameter is between  
25 .008 and .020 inch, and preferably between .012 and .016 inch. While in presently preferred embodiments the wires are of round cross-section, other shapes are also functional.

Anchoring portion 28 is comprised of a set of  
30 struts 38 which are joined at common apex 32 and extend in a diverging manner in a given direction. In Figs. 2, 3 and 6 the anchoring portion extends in a direction opposite to the filter-wires extension, while in Figs. 4, 5 and 7 the anchoring assembly and filter-wires extend  
35 in the same direction, each construction having certain

- 14 -

important advantages. As will be discussed more fully below with reference to Figs. 11 - 24, pointed projections 40 are preferably disposed on struts 38 to engage the vena cava wall 42 and hold the filter in  
5 place.

The struts or devices to engage them to the lumen wall form a ring of contact points or regions which is of generally the same diameter as, and spaced axially from, the ring of contact points between the filter-wires and  
10 the tissue.

The struts 38 thus act to resist tilting and center the vena cava filter and also to hold it in place so that it will not migrate toward the heart or legs. The ability of the vena cava filter to self-center upon  
15 insertion enables highly effective filter performance over a wide range of lumen configurations and placement techniques.

To adequately hold the filter in place, struts 38 exert a radial force normal to the vena cava walls.  
20 Struts 38 are also sufficiently resilient to be compressed into the introducer catheter and to regain their original shape after being released. In presently preferred embodiments, wire having a rectangular or strip cross-section is employed, though oval-shaped or round  
25 cross-sections can also be employed. In the case of rectangular or oval cross-section, the wire is preferably oriented so that the long dimension is parallel with and adjacent to the vena cava wall, with the narrow direction arranged radially. The thickness of the strut wire  
30 preferably is between .003 and .015 inch and more preferably between .005 and .009 inch. The width of the strut wire preferably is between .020 and .045 inch and more preferably between .025 and .035 inch.

Strut wire may be made of the same material as the  
35 filter-wires, such as nickel titanium alloy, titanium,



- 15 -

titanium alloy or stainless steel, or any other biocompatible material having appropriate physical properties.

Strut wires 38 in the embodiments shown in  
5 Figs. 2 -4 preferably are shorter than filter-wires 30 because there is a limited amount of space inside inferior vena cava 12 to implant the filter 10. Additionally, the use of short strut wires provides greater stability to the filter because a greater radial  
10 force may be delivered to the vena cava wall.

The length of contact between the strut wire 38 and the vena cava wall 42 may depend on the vena cava diameter. Figs. 2 and 2b illustrate how multiple pointed projections can be utilized to maintain contact with the  
15 vena cava wall in various diameter vessels.

As shown in Fig. 5, in a preferred embodiment, anchoring portion 28 is comprised of two sets of struts 38a and 38b which are joined at anchoring apex 44. A first set of struts 46 are joined to each other along the  
20 axis for part of their length to form central stem 48 which extends from anchoring apex 44 to common joint 32 with diverging filter-wires. From this region struts 46 diverge in a parallel relation to struts 50. The divergence of the struts from the central axis is much  
25 steeper than the divergence of the filter-wires and the struts are much shorter. Both struts 46 and 50 have generally "s" shaped curved portions. An outer integral extension of struts 50 then turns and straightens to run parallel to the axis to joint 52 with the outer ends of  
30 respective struts 46. The straight portions of struts 50 are parallel to the vena cava wall, exposed for linear engagement with the wall with the ends of struts 46 and 50 pointing in the same direction as the ends of filter-wires 30. The struts overlap the filter-wires to a  
35 limited extent. Pointed projections 40 are disposed on

- 16 -

the linear portions of strut 50 for engagement with the vena cava wall. Struts 46 and 50 thus form a stable "parallelogram" shape in the anchoring assembly. Filter-wires 30 joined to first set of struts 46 at common apex 5 32 are of helical form similar to the other described embodiments.

In Fig. 5 the parallel extension 50a of strut 50 is shown to be in linear contact with the vena cava wall. The contact between vena cava wall 42 and the parallel 10 extension 50a of strut 50 is preserved in the case of smaller diameter vena cava shown in Fig. 5b, due to the action of the parallelogram supports when the assembly is compressed. Although the anchoring portion 28 is compressed in the small diameter case, it merely 15 increases the overlap with the filter-wires and the overall length of the filter unit remains basically unchanged.

In alternative embodiments, shown in Figs. 6 and 7, wall-engaging bars 54 are disposed on the ends of 20 struts 38. The linear contact of bars 54 with the vessel wall provides stability to the filter unit 10 and assures that the filter will be self-centered once placed within vena cava 12. Preferable cross-sectional dimensions for bars 54 fall within the ranges given for struts 38.

25 Preferably, strut 38 and pointed projection 40 are attached to the bar 54 on opposite sides in the same vicinity so that the radial force from the strut is imparted directly on the pointed projection, causing it to securely lodge in vena cava wall 42. Preferably these 30 points of attachment are in the mid-region of bar 54.

As shown in Figs. 8 and 8b, the anchoring portion of Fig. 5 may be used alone as a vena cava filter. Because struts 46 and 50 are not helical, the number of struts in each set can be increased from what is shown to 35 ensure adequate clot capturability. The view of the

- 17 -

anchoring portion in the direction of the longitudinal axis of the vena cava is shown for the large (Fig. 8a) and small (Fig. 8c) diameter cases. As can be seen, the struts of the two sets are circumferentially offset from one another in this embodiment to increase the clot capture aspect presented to the blood stream.

Referring now to Figs. 11 - 24, pointed projections are preferably placed on anchoring portion 28 to engage vena cava wall 42. For the filters shown in Figs. 2 - 4, the vena cava wall contacting region is the end of the strut 38. In filters employing the "parallelogram" shaped double attached strut construction (Figs. 5 and 8), or the bar-type strut construction (Figs. 6 and 7), the pointed projection is preferably centrally located on the parallel strut extension 50a or bar 54. Various types of pointed projections may be used to anchor the vena cava filter, however, the pointed projection should be of limited length to avoid complete penetration of the vena cava walls.

Figs. 11 - 24 show pairs of front and side views of the wall contacting region of anchoring portion 28 which are of magnified scale to illustrate the position of the hooks. As shown in Figs. 11 - 14, 19 - 22, a pointed projection is formed by cutting a strip of metal (or other suitable material) partially from the edge of the wall contacting element while allowing it to remain integral at one end, and permanently bending it upward and inward. Pointed projections made in this fashion, pointing in either direction, are formed in either edge of the wall contacting element.

Alternatively, as shown in Figs. 15 and 16, the wall contacting element may be slit in two places and a separate piece woven into the slits to form hook 40.

Another method of forming a pointed projection is by sharpening the end of strut 38 or bar 54 and bending

- 18 -

it back upon itself, as shown in Figs. 17 and 18. If the tip is bent slightly outward, a stable and reliable hook may be formed. Still another method is to bond a parallel portion of separate hook form member face-wise  
5 to a wall contacting element as shown in Figs. 23 and 24.

It is preferable for the projections to point in both directions, as shown in Figs. 11 - 16, 23 and 24. Vena cava filters should offer resistance to migration in either direction within the vena cava. Projections  
10 pointing in both directions may provide better protection against migration for this effect. Individual projections on adjacent struts may be oriented to point in opposite directions, or pairs of projections extending in opposite directions may be employed.

15 Still other embodiments are within the following claims.

What is claimed is:

- 19 -

1. A vascular filter for placement in a blood vessel for preventing the movement of emboli in the blood stream of a human, the filter including a set of filter-wires that diverge from a central region in a given  
5 direction along the blood vessel forming an emboli-capturing array, the filter wires having portions that engage the vessel wall, and an anchoring assembly defined by at least one set of struts joined centrally with said set of filter-wires, portions of said anchoring assembly  
10 constructed and arranged to engage the wall of said blood vessel in a manner anchoring said filter in position, the region of said anchoring being spaced from the region of contact of said set of filter wires with said vessel wall.

15 2. The vascular filter of claim 1 wherein said anchoring assembly includes anchoring formations each of which is supported and disposed for engagement with the wall of said blood vessel and comprises at least one pointed projection constructed to engage wall tissue and  
20 anchor the strut thereto.

3. The filter of claim 2 wherein each of said anchoring formations comprises at least a pair of pointed projections, the projections of said pair being oriented in opposite directions along the blood vessel, each being  
25 angled to penetrate into wall tissue, said pair of projections being effective to resist dislodgement of said strut in either direction along said vessel.

4. The filter of claim 1 wherein wall-engaging formations supported by said struts are constructed and  
30 arranged to maintain generally linear contact with the vessel walls.

- 20 -

5. The filter of claim 1 wherein said filter-wires of said set are helically configured and arranged, conforming generally to an imaginary cone, to form an effective clot capturing array that can radially expand  
5 and contract to adapt to vessels of different sizes.

6. A vascular filter for placement in a blood vessel for preventing the movement of emboli in the blood stream of a human, the filter comprising an emboli-capturing portion having a set of filter-wires that  
10 diverge from a central region in a given direction along the blood vessel, the wires terminating in free ends constructed to contact the wall of said vessel, at least a major mid-portion of the length of said free ended wires being of generally helical form conforming  
15 generally to an imaginary cone, cooperatively related to form an effective emboli-capturing array.

7. The filter of claim 5 or 6 wherein said filter wires are comprised of elastic metal of round cross-section, and said struts are comprised of flat strip-form  
20 material arranged with the direction of thickness of the strip oriented radially.

8. The filter of claim 5 or 6 wherein said filter-wires are comprised of elastic material, said helical wires being cooperatively related, upon  
25 compaction, to elastically straighten and to meet closely with each other, enabling collapse into a small size, and enabling radial compaction of said set of filter wires into an introducer catheter of about 9 French or less outer diameter for insertion into a blood vessel, said  
30 wires, when released from said catheter into the blood vessel, constructed to expand to form said effective emboli-capturing array.

- 21 -

9. The filter of claim 5 or 6 constructed for placement in blood vessels over a range of sizes, wherein portions of said wires adjacent to said free ends are relatively straight, enabling, substantially, end-contact  
5 of said wires with the walls of said blood vessel over said range of vessel sizes.

10. The filter of claim 5 or 6 wherein all of said wires in said set are curved in the same general helical direction.

10 11. The filter of claim 5 or 6 wherein the wires of said set comprise multiple subsets, the wires of one subset being curved in the opposite helical direction from the helical direction of curvature of another subset.

15 12. The filter of claim 1, 4 or 5 wherein said anchoring assembly comprises anchoring formations distributed about said filter, said anchoring formations being mounted on parallelogram-like supports arranged to adapt to the walls of vessels over a range of sizes while  
20 maintaining substantially the same attitude with respect to the wall of the vessel.

13. The filter of claim 12 wherein said parallelogram-like supports are constructed and arranged to move between expanded and collapsed condition without  
25 change in the overall length of the filter.

14. The filter of claim 1 or 5 wherein the struts of said set diverge from said central region in a direction opposite to the direction of divergence of said set of filter-wires, said struts terminating in portions  
30 that engage the wall of said blood vessel, the spacing of

- 22 -

the regions of contact of said sets of filter-wires and said struts with the vascular wall being selected to stabilize said filter in said vessel in a generally centered relationship.

5           15. The filter of claim 14 wherein wall-engaging formations supported by said struts are constructed and arranged to maintain generally linear contact with the vessel walls.

10           16. The filter of claim 15 wherein said wall-engaging formations are linear elements each supported in its mid-region by a strut of said set.

15           17. The filter of claim 1 or 5 wherein the struts are short relative to said filter-wires and diverge in the same direction as said filter-wires but at a greater angle relative to the longitudinal axis of the filter, the spacing of the regions of contact of said filter-wires and said struts with the vascular wall being selected to stabilize said filter in said vessel in a generally centered relationship.

20           18. The filter of claim 17 wherein outer, wall-engaging formations supported by said struts are constructed and arranged to maintain generally linear contact with the vessel wall.

25           19. The filter of claim 18 wherein said wall-engaging formations are linear elements each supported in its mid-region by a strut of said set.

            20. The filter of claim 18 wherein said wall-engaging formations are linear elements, each of said linear elements being supported at one end by a



- 23 -

respective strut of said set, and the other end of each of said linear elements being joined to and supported by a respective strut of a second set of struts of said assembly.

5           21. The filter of claim 20 wherein each of said linear elements comprises an integral extension of at least one of the respective supporting struts.

          22. The filter of claim 20 wherein said struts in said second set are centrally joined at a location spaced  
10 axially from the region at which said first set of struts are joined, and are arranged to provide effectively parallelogram-like support to said linear wall-engaging elements to assure substantially linear contact thereof with the vessel wall over a range of sizes of the vessel.

15           23. The filter of claim 1 or 5 wherein said struts have free end portions constructed to engage the wall of said vessel, there being a plurality of anchoring formations on a said strut, said formations arranged so that one said formation is relatively more effective for  
20 anchoring in walls of blood vessels of relatively large size and the other formation is relatively more effective for anchoring in walls of smaller size vessels.

          24. The filter of claim 23 wherein each said anchoring formation comprises at least one pointed  
25 projection.

          25. The filter of claim 23 wherein each said anchoring formation comprises at least one pair of pointed projections, the projections of said pair being oriented in opposite directions along the blood vessel,  
30 each being angled to penetrate into wall tissue, said

- 24 -

pair of projections effective to resist dislodgement of said strut in either direction along said vessel.

26. The filter of claim 5 wherein said filter wires are of round cross-section.

5           27. The filter of claim 1, 5 or 26 wherein said struts are of rectangular transverse cross-section, the thin dimension of said strut cross-section being arranged in the radial direction.

28. The filter of claims 1 or 5 wherein a surface  
10 treatment is included on said struts or wires that enhances their effectiveness.

29. The filter of claim 28 wherein said surface treatment comprises a biocompatible polymeric coating.

30. The filter of claim 28 wherein said surface  
15 treatment comprises a metal coating.

31. A vascular filter for placement in blood vessels for preventing the movement of emboli in the blood stream of a human, said filter including an anchoring assembly wherein said anchoring assembly  
20 comprises anchoring formations distributed about said filter, said anchoring formations mounted on parallelogram-like supports arranged to adapt to the walls of vessels over a range of sizes.

32. The vascular filter of claim 31 wherein said  
25 supports themselves form at least part of an emboli-capturing array.

- 25 -

33. The vascular filter of claim 31 or 32 wherein outer wall-engaging elements are constructed and arranged to make generally linear contact with the vessel wall, one end of each of said wall-engaging elements being  
5 joined to and supported by a strut of a first set of struts, and the other end of each of said wall-engaging elements being joined to and supported by a respective strut of a second set of struts wherein said second set of struts are centrally joined at a location spaced  
10 axially from the region at which said first set of struts are joined, and are arranged to provide effectively parallelogram-like support to said outer, linear wall-engaging elements.

34. The vascular filter of claim 33 wherein each  
15 said linear wall-engaging element comprises an integral extension of at least one of the respective supporting struts.

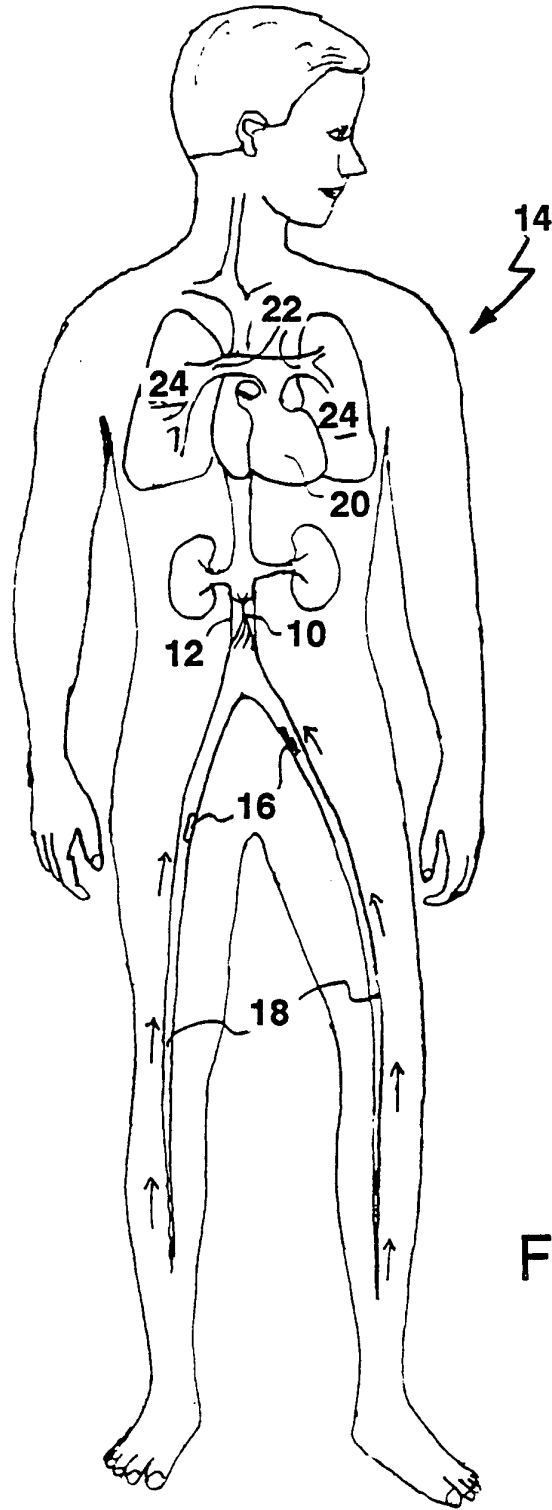

FIG. 1

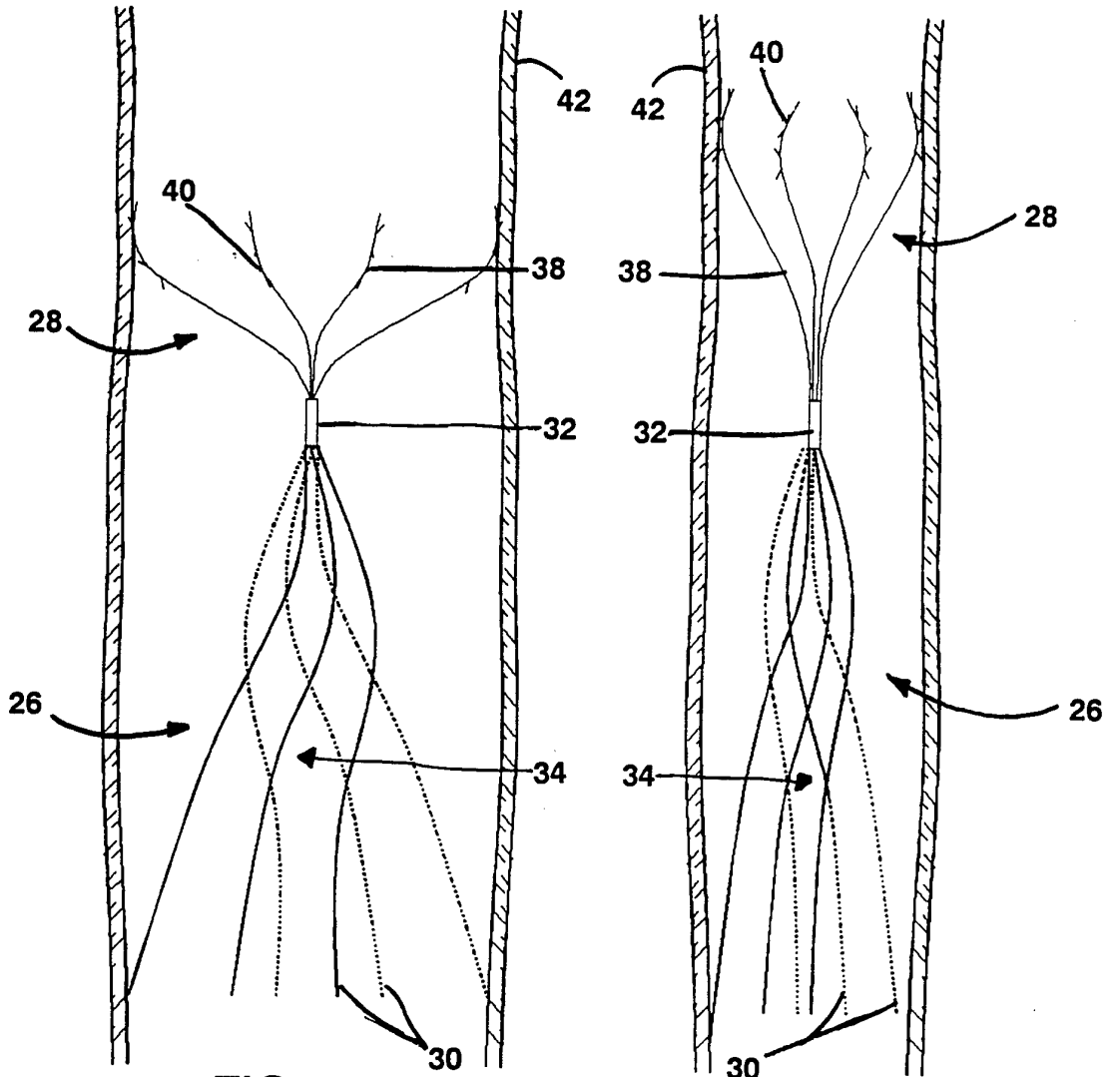

FIG. 2

FIG. 2b

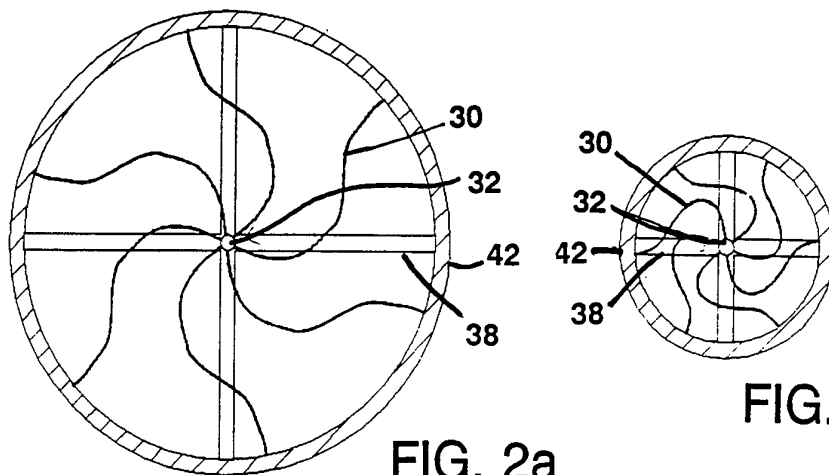

FIG. 2a

FIG. 2c

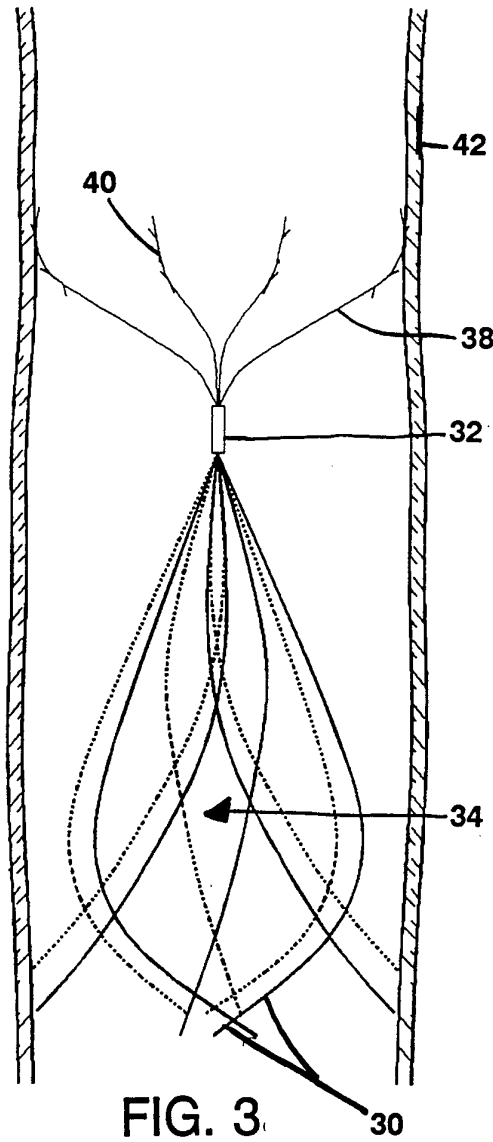

FIG. 3

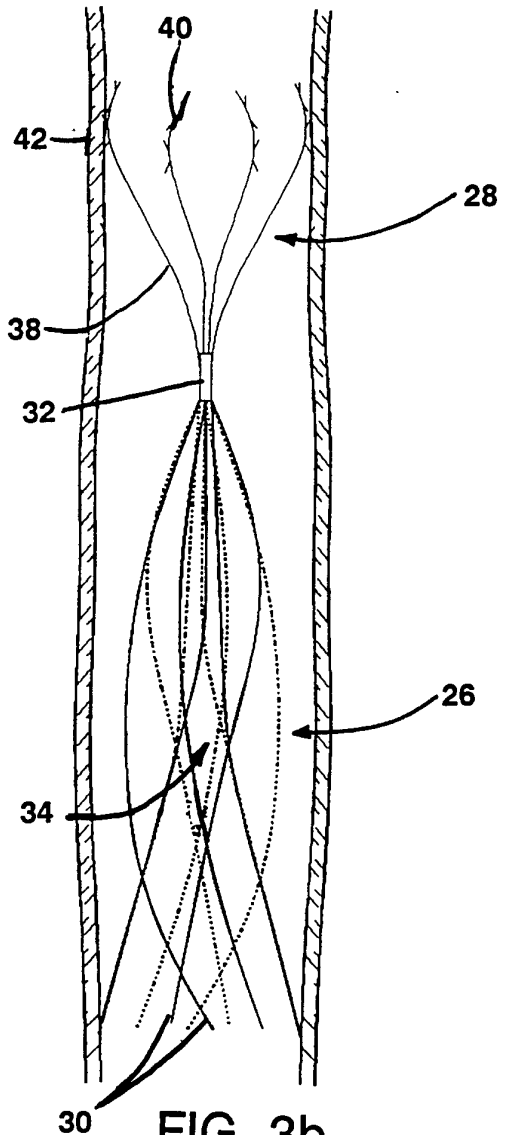

FIG. 3b

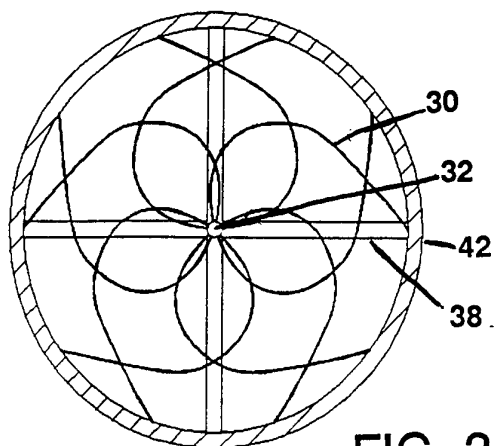

FIG. 3a

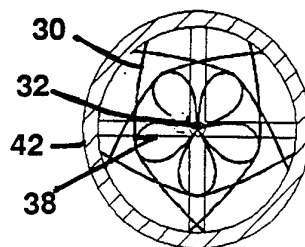

FIG. 3c

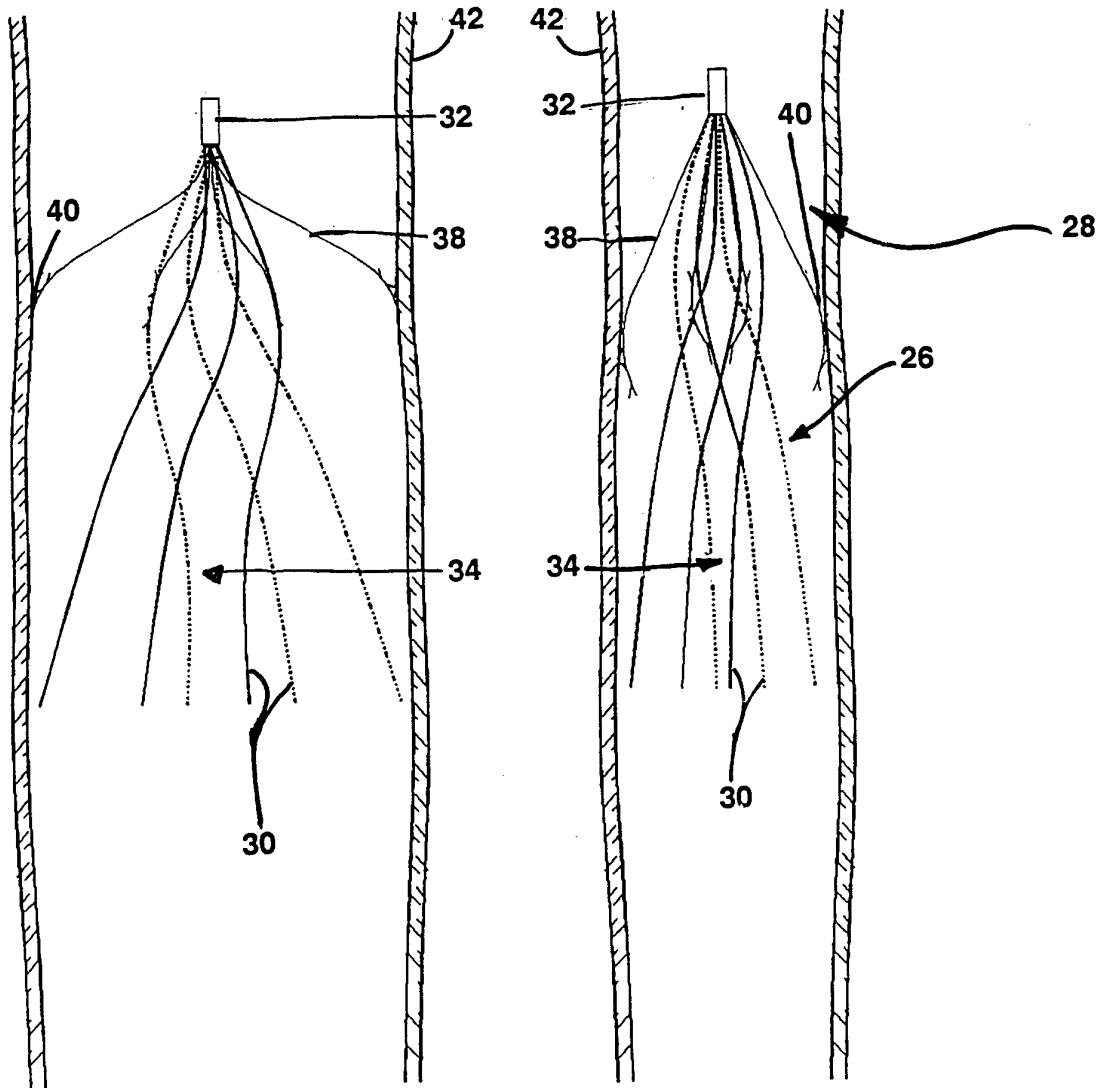

FIG. 4

FIG. 4b

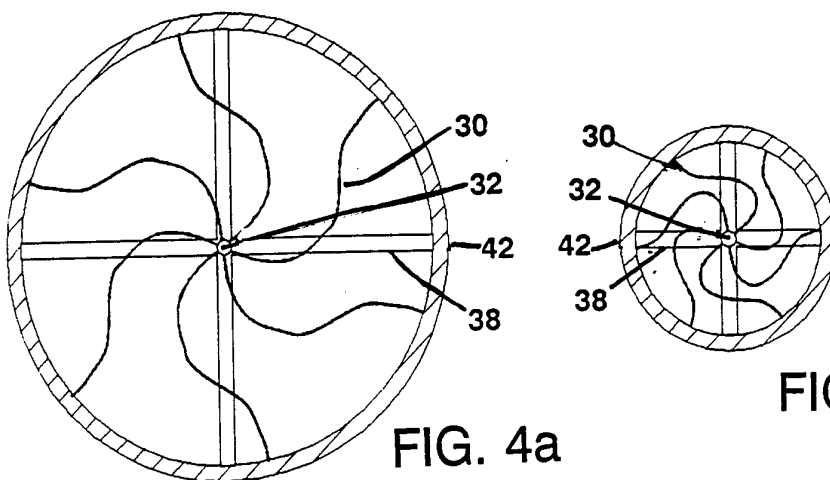

FIG. 4a

FIG. 4c

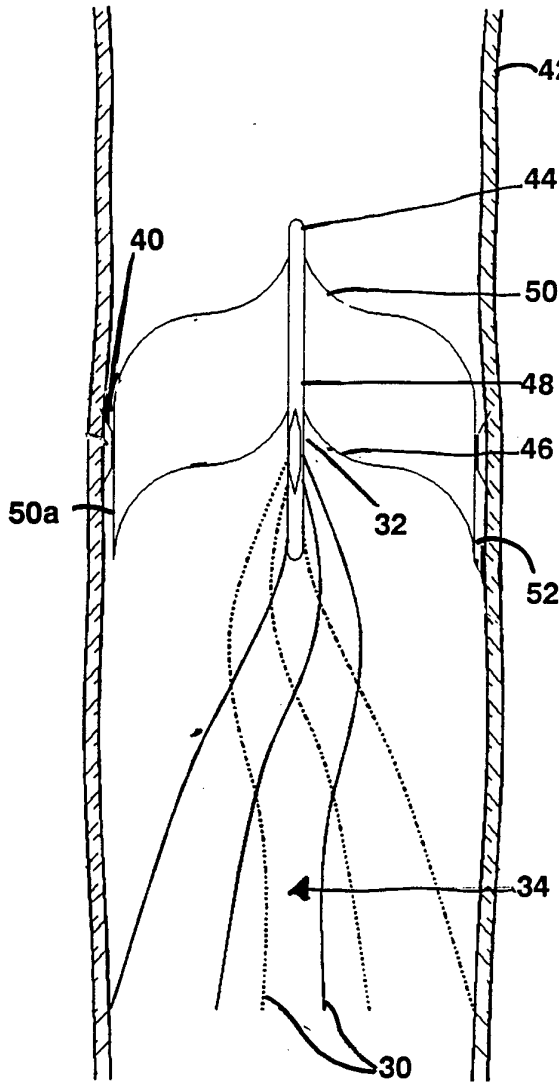

FIG. 5

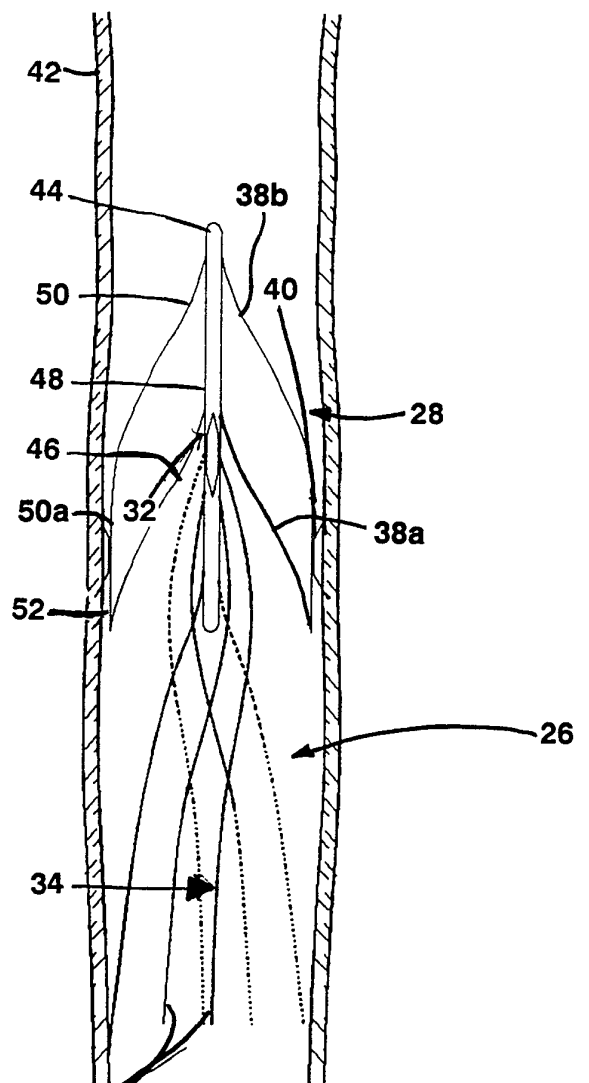

FIG. 5b

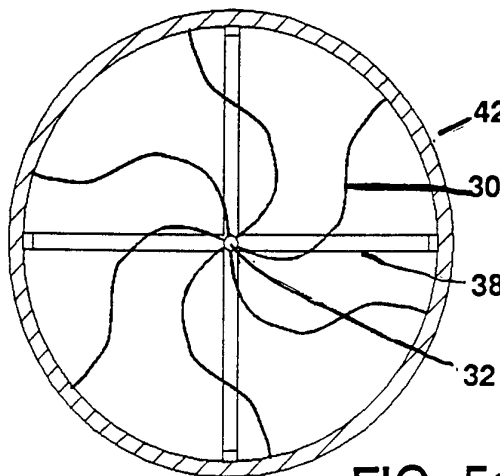

FIG. 5a

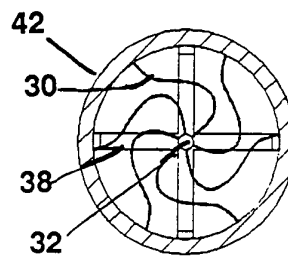

FIG. 5c



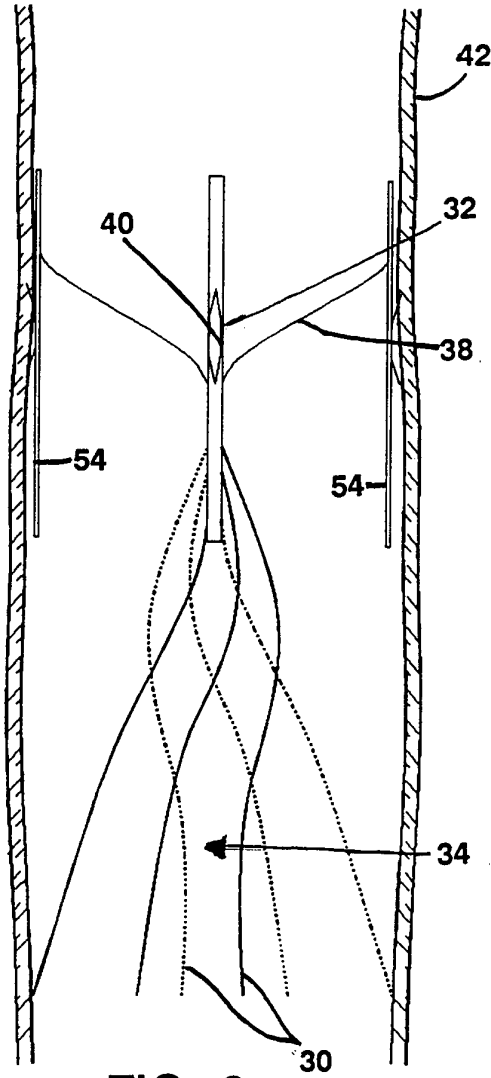

FIG. 6

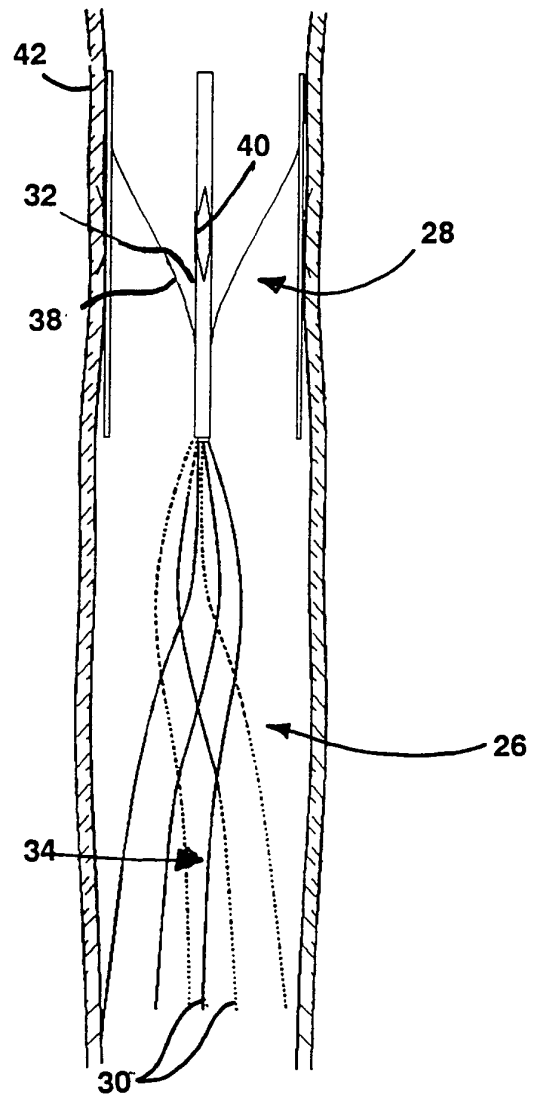

FIG. 6b

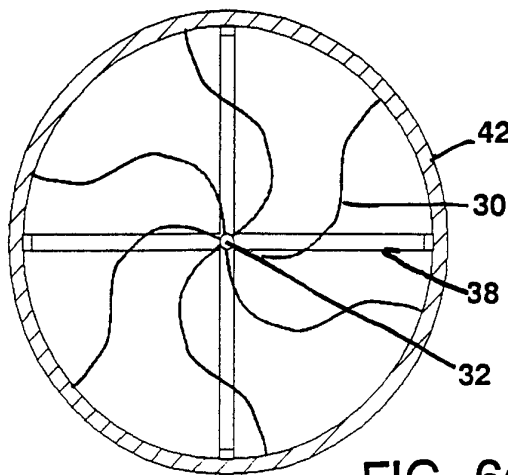

FIG. 6a

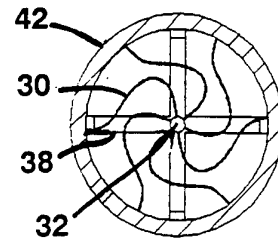

FIG. 6c

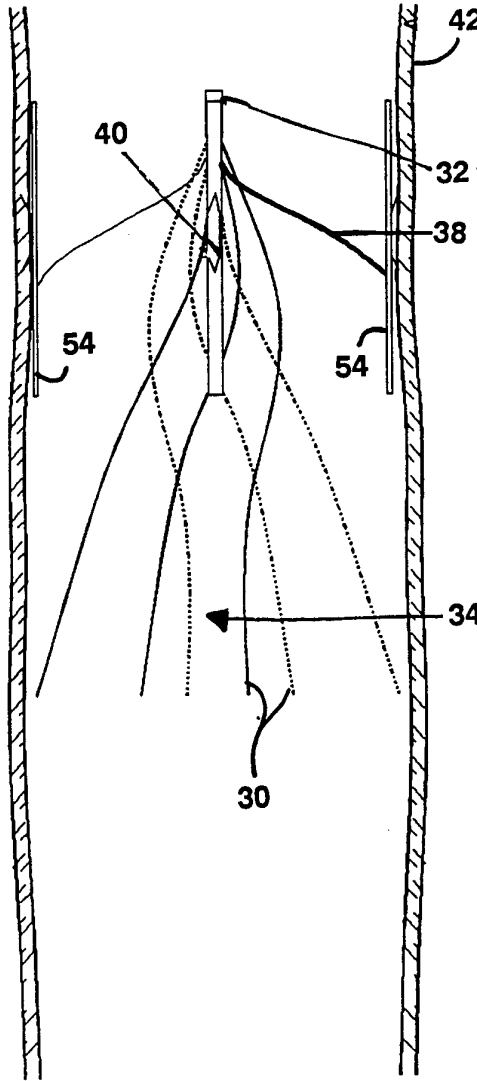

FIG. 7

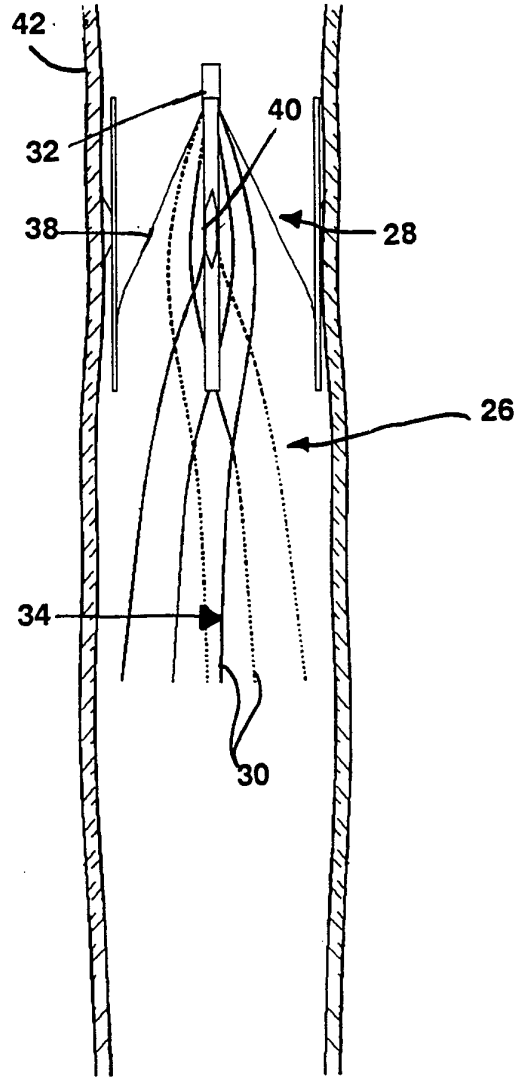

FIG. 7b

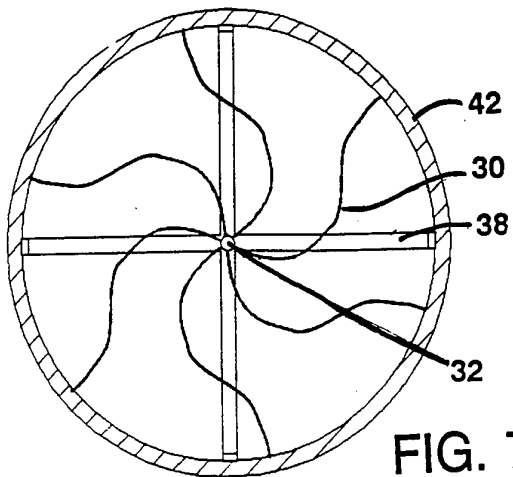

FIG. 7a

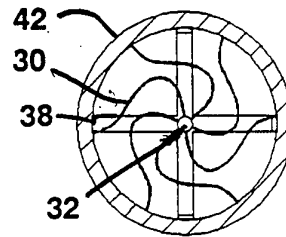

FIG. 7c

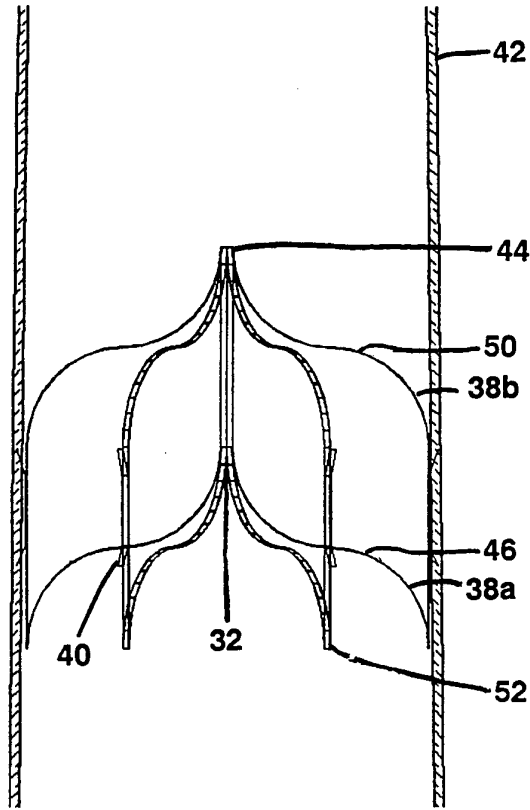

FIG. 8

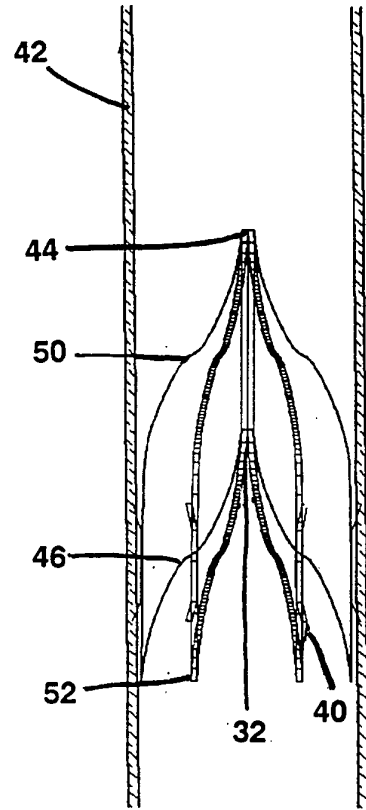

FIG. 8b

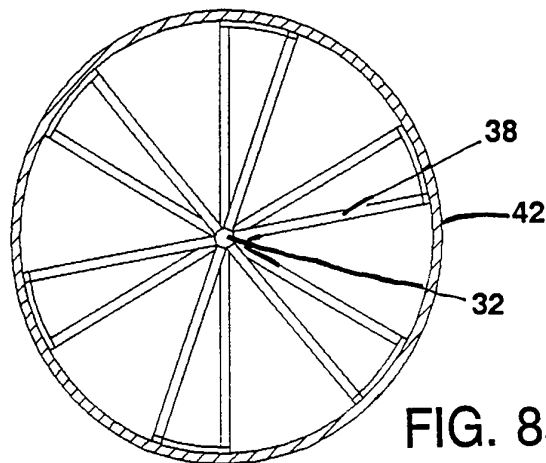

FIG. 8a

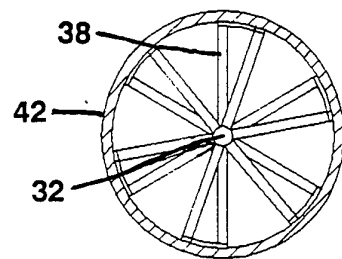

FIG. 8c

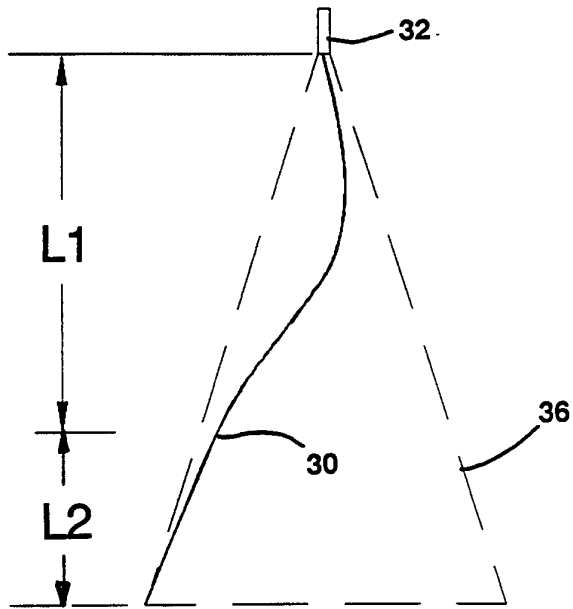

FIG. 10

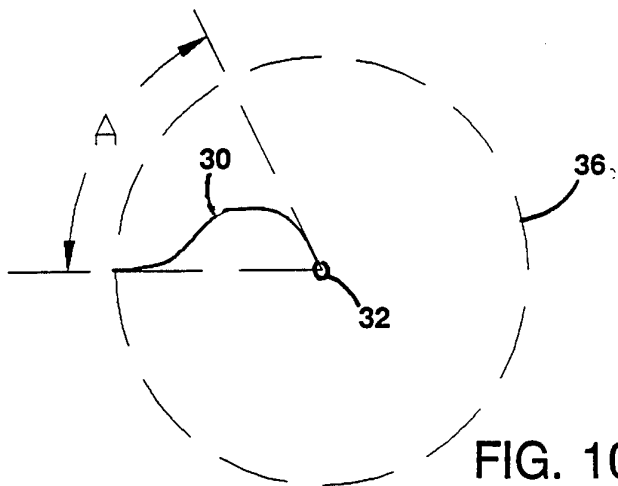

FIG. 10a

FIG. 9a

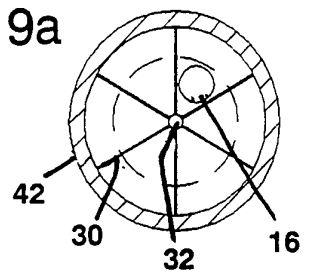

FIG. 9

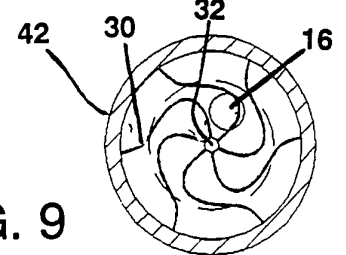

FIG. 11

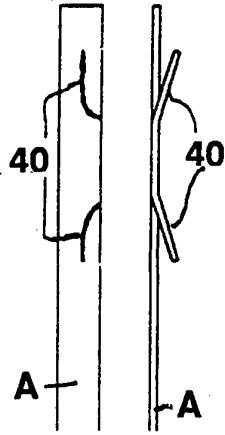

FIG. 13

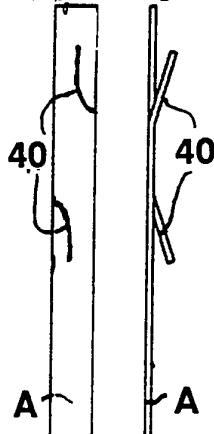

FIG. 15

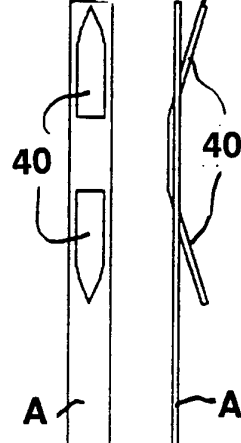

FIG. 12

FIG. 14

FIG. 16

FIG. 17

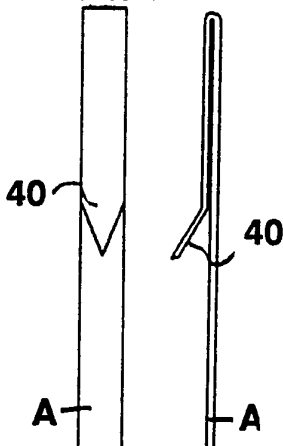

FIG. 19

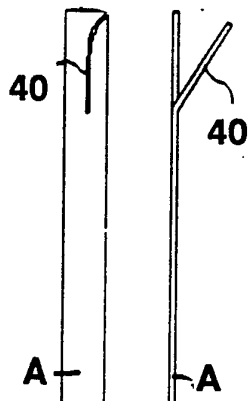

FIG. 21

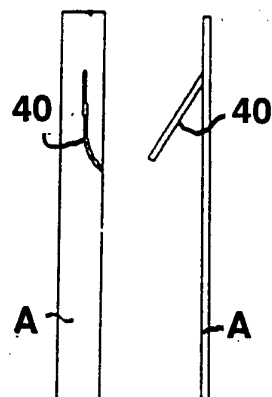

FIG. 18

FIG. 20

FIG. 22

FIG. 23

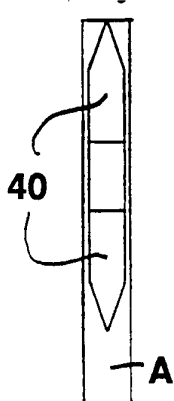
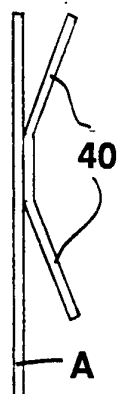

FIG. 24



**INTERNATIONAL SEARCH REPORT**

International application No.  
PCT/US94/11208

**A. CLASSIFICATION OF SUBJECT MATTER**  
 IPC(5) :A61B 17/00  
 US CL :606/200  
 According to International Patent Classification (IPC) or to both national classification and IPC

**B. FIELDS SEARCHED**  
 Minimum documentation searched (classification system followed by classification symbols)  
 U.S. : 606/191, 194, 198, 200; 128/899

Documentation searched other than minimum documentation to the extent that such documents are included in the fields searched

Electronic data base consulted during the international search (name of data base and, where practicable, search terms used)

**C. DOCUMENTS CONSIDERED TO BE RELEVANT**

Category*	Citation of document, with indication, where appropriate, of the relevant passages	Relevant to claim No.
X	US, A, 4,781,177 (Lebigot) 01 November 1988, see entire.	1, 2, 4, 31-34
X	US, A, 4,832,055 (Palestrant) 23 May 1989, see entire document.	1, 2, 4

Further documents are listed in the continuation of Box C.       See patent family annex.

- |   |  |
|---|--|
| * Special categories of cited documents:  | "T" later document published after the international filing date or priority date and not in conflict with the application but cited to understand the principle or theory underlying the invention  |
| "A" document defining the general state of the art which is not considered to be part of particular relevance   | "X" document of particular relevance; the claimed invention cannot be considered novel or cannot be considered to involve an inventive step when the document is taken alone   |
| "E" earlier document published on or after the international filing date  | "Y" document of particular relevance; the claimed invention cannot be considered to involve an inventive step when the document is combined with one or more other such documents, such combination being obvious to a person skilled in the art |
| "L" document which may throw doubts on priority claim(s) or which is cited to establish the publication date of another citation or other special reason (as specified) | "&" document member of the same patent family  |
| "O" document referring to an oral disclosure, use, exhibition or other means  |  |
| "P" document published prior to the international filing date but later than the priority date claimed  |  |

Date of the actual completion of the international search 05 February 1995	Date of mailing of the international search report <b>27 FEB 1995</b>
---	--

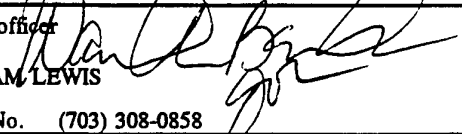
Name and mailing address of the ISA/US Commissioner of Patents and Trademarks Box PCT Washington, D.C. 20231 Facsimile No. (703) 305-3230	Authorized officer  WILLIAM LEWIS Telephone No. (703) 308-0858
---	---