

[54] FANCY STITCH ZIGZAG SEWING MACHINES

[75] Inventors: Walter H. W. Marsh, Fanwood; Lionel J. Coulombe, Matawan, both of N.J.

[73] Assignee: The Singer Company, New York, N.Y.

[22] Filed: Jan. 4, 1971

[21] Appl. No.: 38,596

Related U.S. Application Data

[62] Division of Ser. No. 827,867, May 26, 1969, Pat. No. 3,585,876.

[52] U.S. Cl.112/158 B

[51] Int. Cl.D05b 3/02

[58] Field of Search.....112/158 R, 158 A, 158 B, 112/158 D, 112/77; 74/567

[56] References Cited

UNITED STATES PATENTS

3,083,657	4/1963	Theenhausen et al.....	112/158
3,113,537	12/1963	Bono.....	112/158

Primary Examiner—Werner H. Schroeder
Attorney—Marshall J. Breen et al.

[57] ABSTRACT

A zigzag sewing machine is disclosed which can exchangeably accommodate any one of a variety of differently organized special cam units for producing special patterns of zigzag stitches, zigzag stitch patterns combined with patterned work feed control, or closed stitch groups such as buttonholes.

1 Claim, 19 Drawing Figures

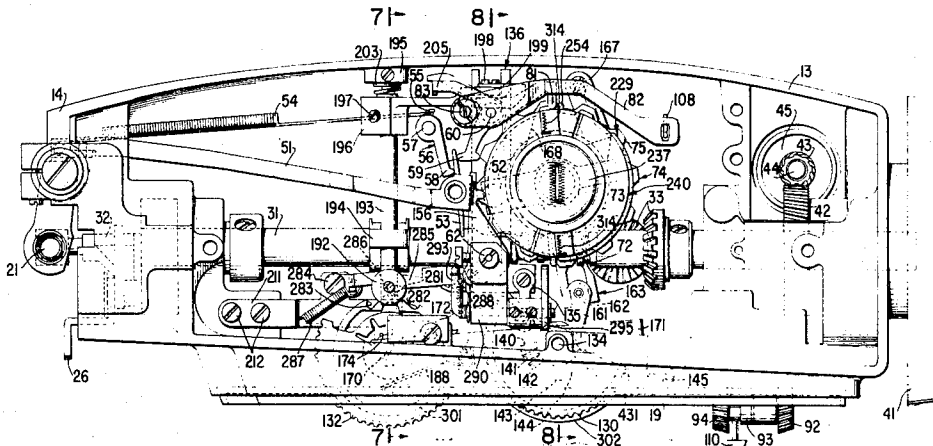

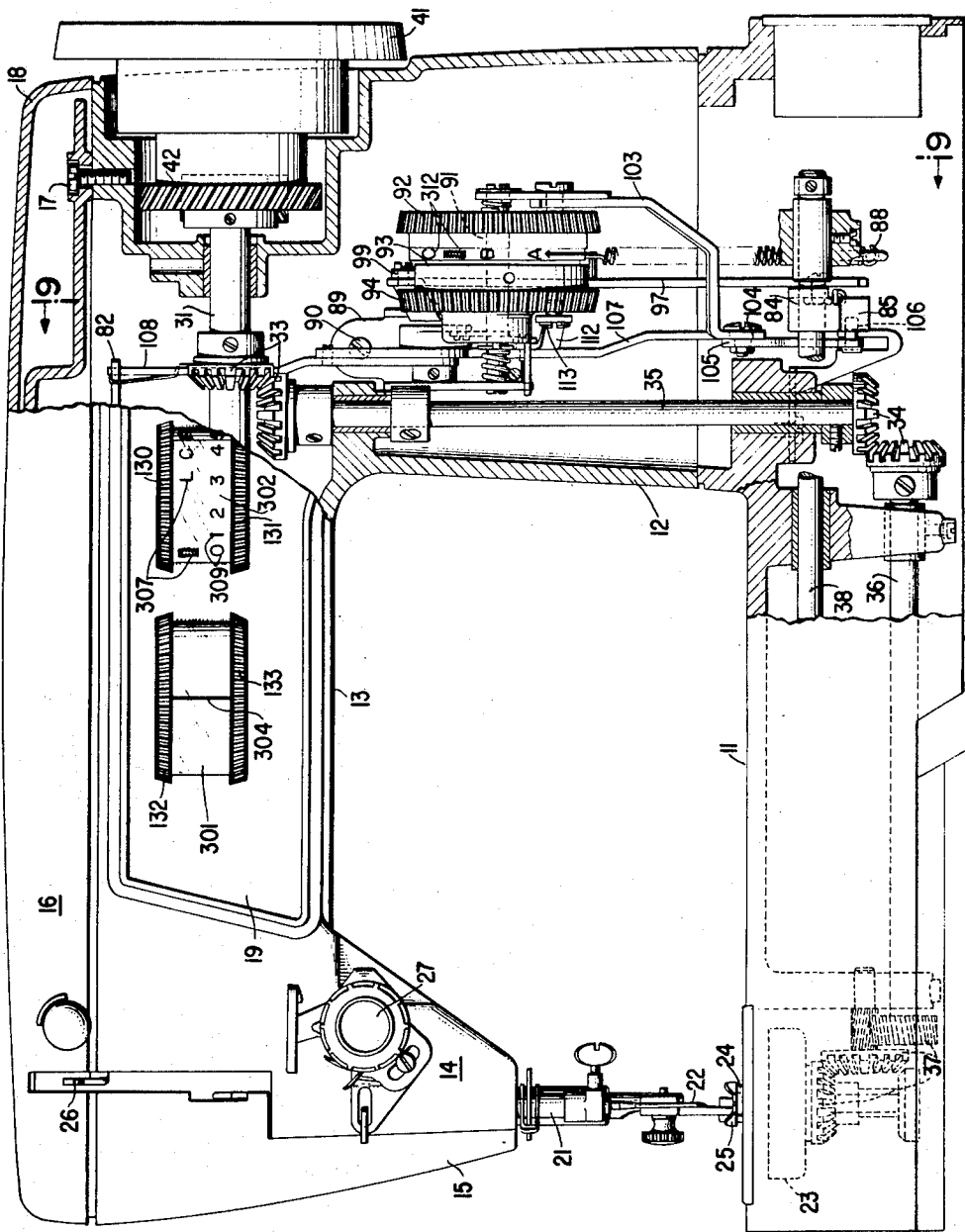

Fig. 1

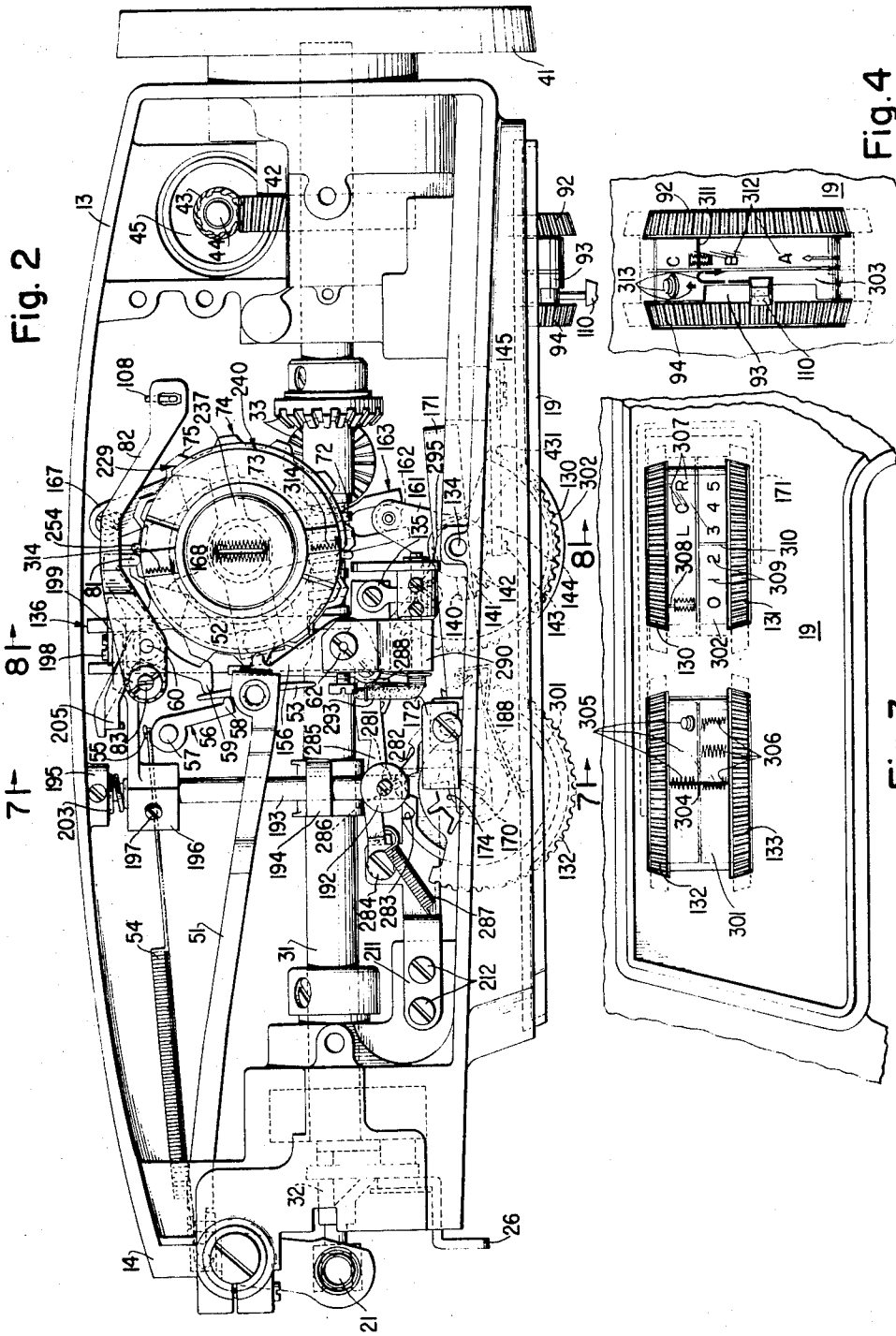

Fig. 2

Fig. 4

Fig. 3

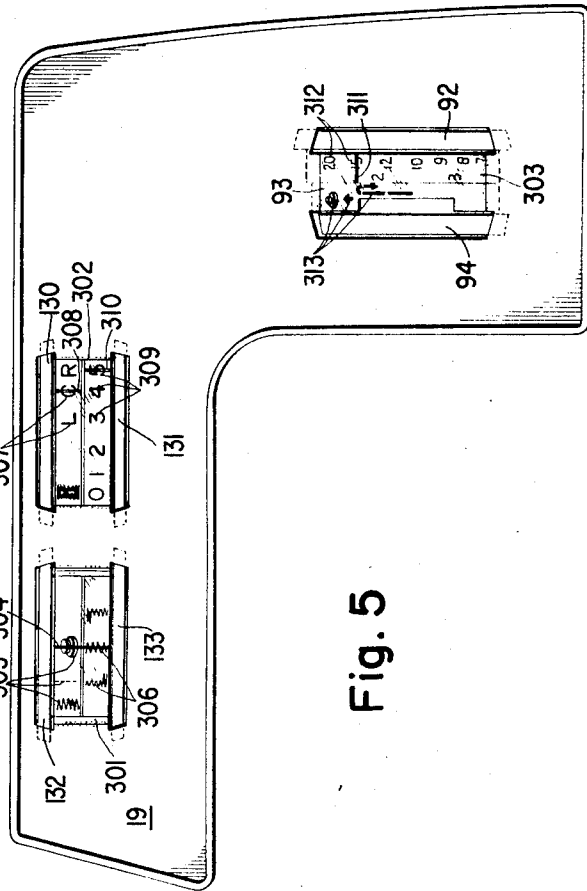
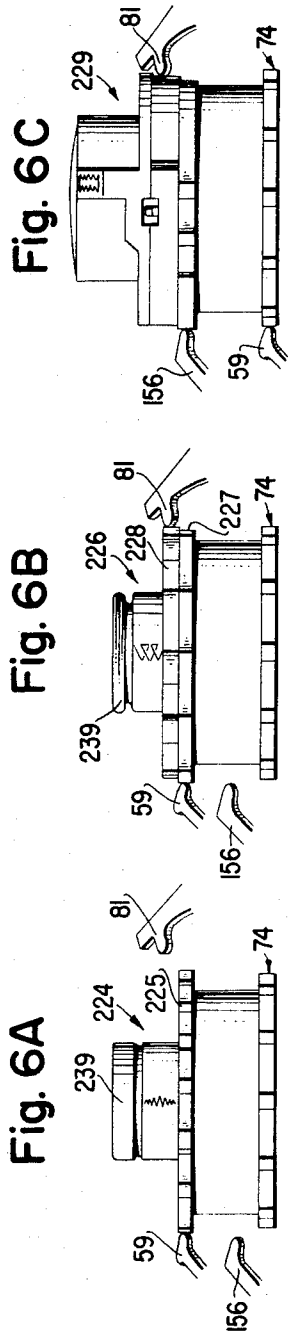

Fig. 5

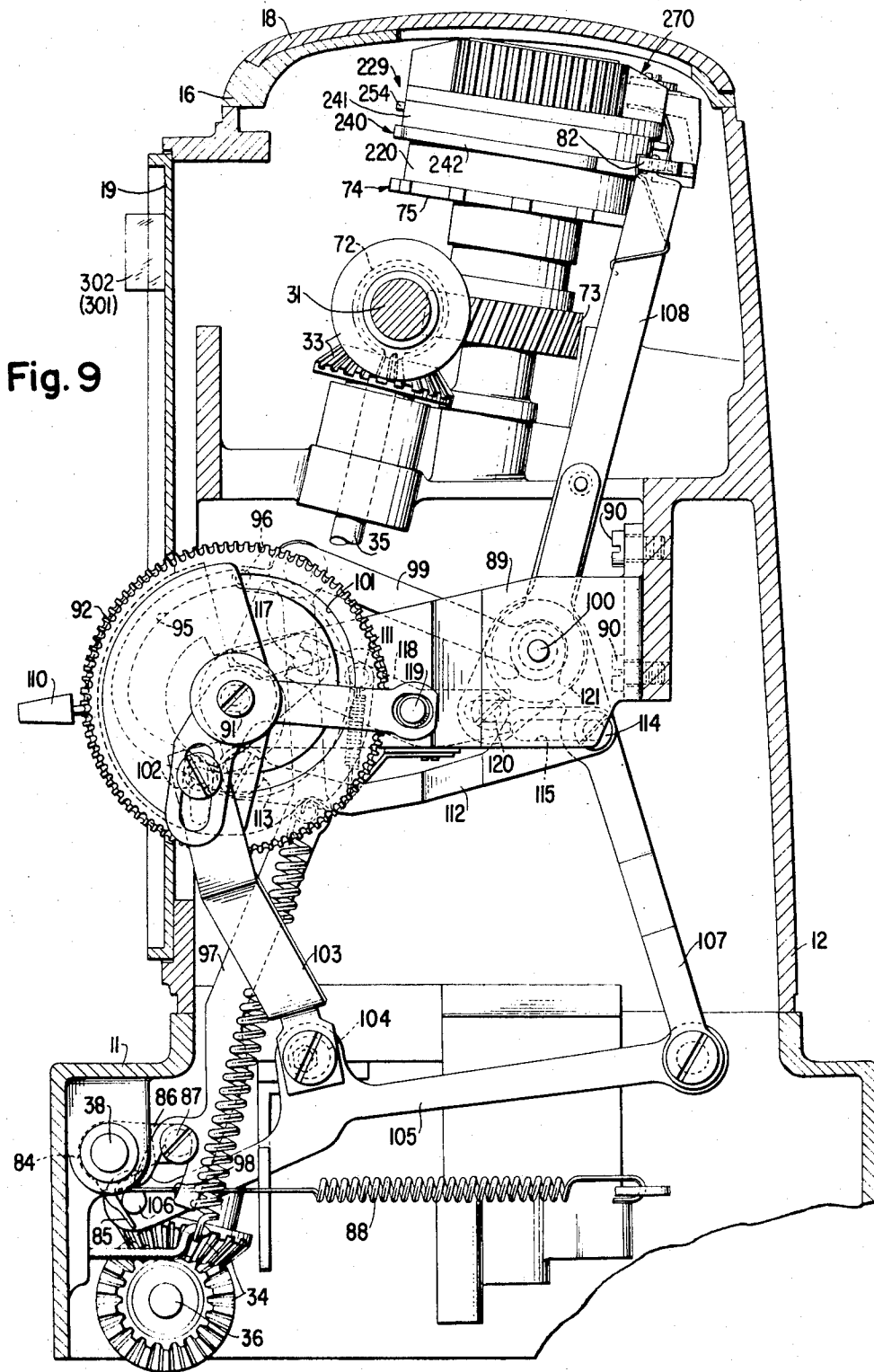

Fig. 10

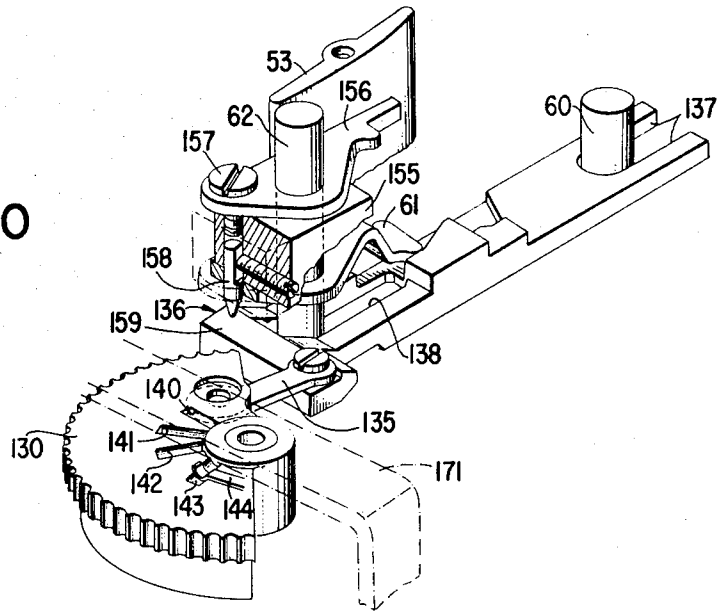

Fig. 11

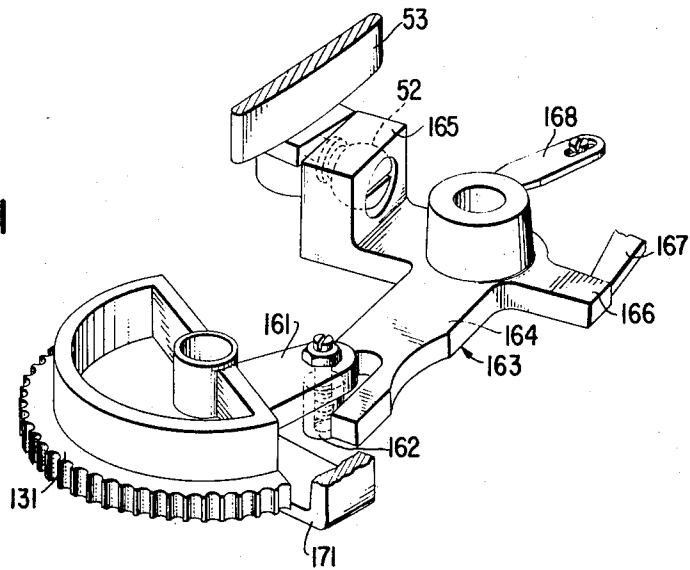

Fig. 12

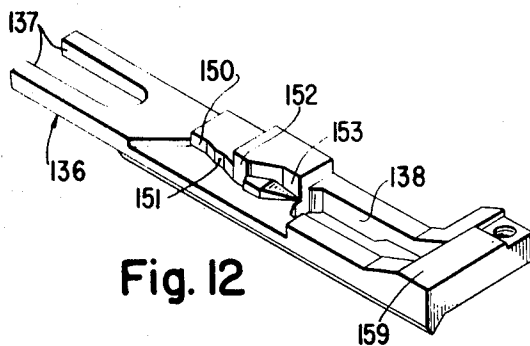

Fig. 13

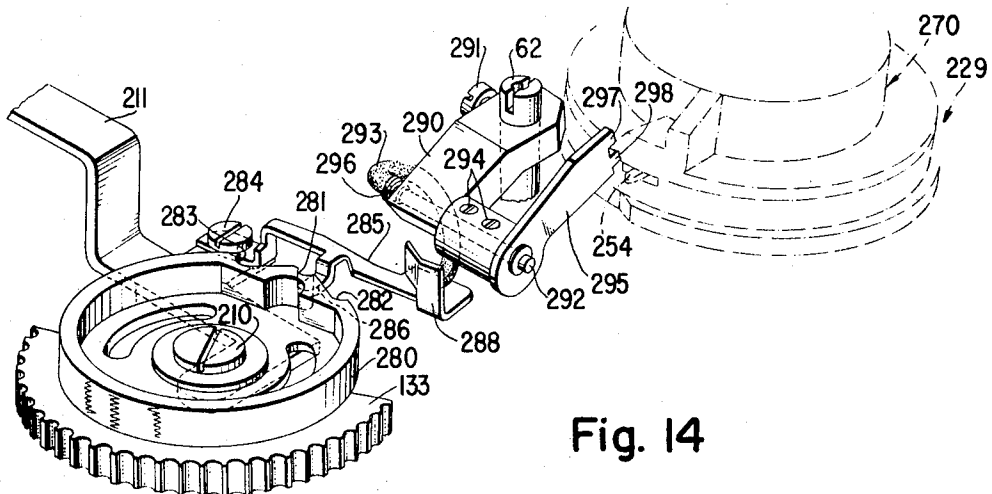
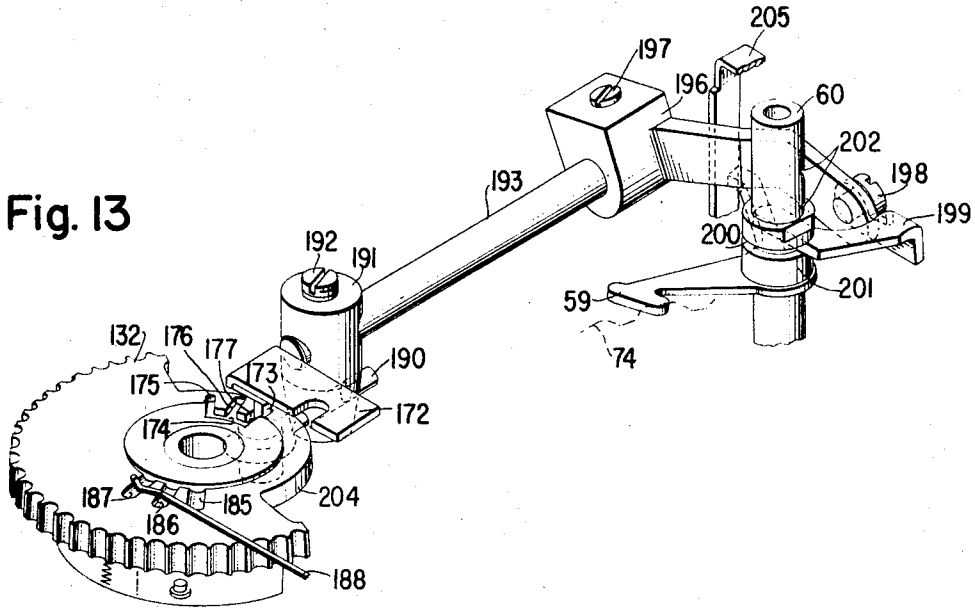

Fig. 14

FANCY STITCH ZIGZAG SEWING MACHINES

This is a division of United States patent application Ser. No. 827,867, filed May 26, 1969, now U.S. Pat. No. 3,585,876.

BACKGROUND OF THE INVENTION

This invention relates to zigzag sewing machines in which control of the lateral jogging movements of the needle, of the neutral position of needle vibration, and of the direction and magnitude of work feed may be accomplished by pattern cam means.

It is an object of this invention to provide a zigzag sewing machine with a novel drive and novel control instrumentalities for the needle jogging and work feed mechanisms which can exchangeably accept cam units which are differently organized and differently driven to influence different ones or combinations of the control instrumentalities in order that a wide variety of fancy stitching may be accomplished.

It is known in the prior art to provide for insertion or exchange in a sewing machine of cam units which are all of one predetermined organization. The U.S. Pat. of R.E. Johnson No. 2,986,016 dated June 20, 1961, for example, discloses a construction in which exchangeable cams are provided for influencing only the lateral jogging movements of the needle. The U.S. Pat. of Casas-Robert et al. No. 2,682,845 dated July 6, 1954 discloses a sewing machine in which an exchangeable cam unit is provided having three cams, one for lateral needle jogging, one for needle position, and one for work feed control. The U.S. Pat. of W. Engel, No. 2,983,240, May 9, 1961, discloses a sewing machine in which a cam unit for influencing the needle position and the work feed control may be intermittently driven so as to provide for the sewing of closed stitch groups such as buttonholes. The buttonholing cam of the Engel patent is shifted lengthwise of the cam shaft when it is clutched to or disengaged therefrom. In each of these prior art disclosures, although the cam units with differing cam profiles might be substituted, the organization thereof is such that the selected cam unit must always influence the same mechanisms or controls in the sewing machine.

SUMMARY OF THE INVENTION

The present invention augments these prior art disclosures by the provision in a zigzag machine of an exchangeable cam unit reception means which is common to a variety of differently organized and differently driven cam units together with novel and effective operator influenced means for orienting the needle jogging and work feed controls to accommodate any selected one of the differently organized exchangeable cam units.

It is an object of this invention to provide in a zigzag sewing machine, an exchangeable cam unit reception means which can accommodate cam units adapted to be continuously driven for controlling zigzag motion of the needle or combined needle jogging and work feed controls, and can also accommodate cam units adapted to be driven periodically and used to control the formation of stitch groups such as buttonholes and the like.

DESCRIPTION OF THE DRAWINGS

With the above and additional objects and advantages in view as will hereinafter appear this invention comprises the devices, combinations, and arrangements of parts hereinafter described and illustrated in the accompanying drawings of a preferred embodiment in which:

FIG. 1 is a front elevational view of a sewing machine, partly in vertical section having this invention applied thereto,

FIG. 2 is a top plan view of the sewing machine in FIG. 1 with the top and end cover plates removed,

FIG. 3 is a fragment of the sewing machine escutcheon plate in front elevation including the control dials for the needle jogging controls shown in the positions illustrated in FIG. 2,

FIG. 4 is a fragment of the sewing machine escutcheon plate in front elevation including the control dials for the work feeding mechanism,

FIG. 5 is a front elevational view of the entire escutcheon plate showing the dials set for the beginning of buttonhole sewing operation,

FIG. 6A is a semi-diagrammatic elevational view of the cam stack with a plain needle jogging cam placed thereon and indicating the cam follower arrangement for cooperation therewith,

FIG. 6B is a semi-diagrammatic elevational view similar to FIG. 6A but illustrating a set of needle jogging and work feed controlling cams placed on the cam stack and indicating the cam follower arrangement for cooperation therewith,

FIG. 6C is a semi-diagrammatic elevational view of the cam stack with the cam unit for buttonholing placed thereon and indicating the cam follower arrangement for cooperation therewith,

FIG. 7 is a cross sectional view taken transversely through the bracket arm substantially along line 7-7 of FIG. 2,

FIG. 8 is a cross sectional view taken substantially through the bracket arm substantially along line 8-8 of FIG. 2,

FIG. 9 is a vertical cross sectional view taken through the standard substantially along line 9-9 of FIG. 1,

FIG. 10 is a detached perspective view of the control arrangement for the neutral position of needle vibration for the zigzag mechanism of this invention,

FIG. 11 is a detached perspective view of the bight control arrangement for the zigzag mechanism of this invention,

FIG. 12 is a detached perspective view of the slider which forms a part of the vertical position control arrangement illustrated in FIG. 10,

FIG. 13 is a detached perspective view of the cam selection arrangement of the zigzag mechanism of this invention,

FIG. 14 is a detached perspective view of the buttonhole cam unit clutch control arrangement of this invention,

FIG. 15 is an enlarged cross sectional view of the cam shaft of the sewing machine of FIGS. 1 and 2 with the buttonhole cam unit thereon,

FIG. 16 is an exploded perspective view of the buttonhole cam unit, and

FIG. 17 is a bottom view of the buttonhole cam unit of this invention.

Referring to FIGS. 1, 2, and 9, this invention is illustrated in the accompanying drawings as embodied in a sewing machine having a frame including a work supporting bed 11, a hollow standard 12 rising from the bed and supporting a bracket arm 13 terminating in a sewing head 14 overhanging the bed. A hinged end cover plate 15 serves to close the sewing head 14, and a top cover plate 16 is secured over the bracket arm 13 as by fastening screw 17. The top cover plate is formed with a hinged lid 18 which provides access to an exchangeable pattern cam unit in the bracket arm as will be described hereinbelow.

The front portion of the bracket arm and standard of the sewing machine frame is closed by a detachable escutcheon plate 19 which is illustrated in FIG. 5 and through which the various controls for the instrumentalities within the sewing machine frame project.

Carried in the sewing head 14 for endwise reciprocation and lateral jogging movement is a needle bar 21 to which an eye-pointed thread carrying needle 22 is secured. The needle cooperates in the formation of stitches with a loop taker indicated generally at 23 carried in the work supporting bed. Also carried in the work supporting bed is a work feeding mechanism including work engaging feed dog 24 which engages work fabric on the work supporting bed in opposition to a presser foot 25 supported in the sewing head 14. Also carried in the sewing head is a needle take-up device 26 and a needle thread tensioning device 27. The stitch forming instrumentalities thus far described may be of any conventional construction.

Indicated at 31 is a main shaft which is journaled lengthwise in the bracket arm and which by means of a crank 32 as illustrated in FIG. 2 serves to impart endwise reciprocation to the needle bar and to actuate the needle thread take-up. By means of gear sets 33 and 34 and a vertical shaft 35 in the standard, the main shaft 31 imparts rotary movement to a bed shaft 36. By means of gearing indicated at 37 in the work supporting bed the bed shaft imparts rotation to the loop taker 23 in timed relation with reciprocation of the needle for the formation of stitches. While the work feeding mechanism may be of any conventional construction and the feed mechanism is not illustrated in detail in the accompanying drawings, a feed mechanism as disclosed in U.S. Pat. No. 3,527,183, issued on Sept. 8, 1970, is particularly well suited for use in the sewing machine illustrated herein and this patent application may be referred to for a more detailed description thereof. A stitch length regulating shaft 38 journaled lengthwise in the work supporting bed serves to set the work feeding mechanism for the desired stitch length and direction of feed. The means for influencing the position of the stitch length regulating shaft 38 either manually or by the influence of a pattern cam device will be described hereinbelow.

As illustrated in FIGS. 1 and 2, a hand wheel is carried by the sewing machine main shaft and is associated with a worm wheel 42 meshing with a worm 43 carried on a drive shaft 44 of an electric motor 45 arranged in the hollow standard 12. Referring to FIG. 2, a pivoted control link 51 is illustrated for imparting lateral jogging movement to the needle bar. The extremity of the control link remote from the needle bar is formed with a spherical stud 52 by which the position of the

control link may be influenced as will be described hereinbelow. Adjacent to the spherical stud a wobble plate 53 is pivoted to the control link. A spring 54 is secured at one extremity to the control link adjacent to the needle bar and is secured at the other extremity to one arm 55 of a biasing lever 56 fulcrumed on a stud 57 in the bracket arm. The other arm 58 of the biasing lever bears against the wobble plate 53 serving to bias the control link 51 toward the right as viewed in FIG. 2. The wobble plate is influenced by two cam follower elements; a first cam follower element 59 which is pivoted on a vertical stud 60 arranged rearwardly in the bracket arm and a second cam follower 61 element which is pivotally mounted on a vertical stud 62 arranged forwardly within the bracket arm. The above described needle jogging linkage is contrived so that the movements of the first and second cam followers are integrated by the wobble plate into a composite needle jogging motion which is imparted by the control link to the needle bar. This needle jogging mechanism may be of the type described in greater detail in the United States Pat. No. 2,862,468 to which reference may be had.

For imparting pattern information to the cam followers 59 and 61, a cam shaft 71 is journaled in the bracket arm and driven by a worm 72 formed on the main shaft which meshes with a worm wheel 73 fast on the cam shaft. The cam shaft has fast thereon a single cam disk 74 having peripheral cam lobes 75 which may be tracked by the first cam follower 59. The second cam follower 61 is designed, as will be described in detail hereinbelow to be influenced not by the cam disk 74 but by either a manually controlled arrangement or by a special exchangeable pattern cam unit which may be selectively positioned above the cam disk 74. As will also be described in detail hereinbelow, the first cam follower 59 may also be positioned as to track an exchangeable pattern cam element selectively positioned on the cam shaft above the cam disk 74.

A pattern cam exchangeably accommodated on the cam shaft above the cam disk 74 may also be tracked by a work feed controlling cam follower 81 which preferably takes the form of a lever fulcrumed on the vertical stud 60. Also fulcrumed on the stud 60 is a transmission lever 82 fastened by a screw 83 to the work feed controlling follower. FIGS. 1 and 9 best illustrate the work feed control arrangement by which the angular position of the stitch length regulating shaft 38 in the bed may be influenced either manually or in accordance with the cam influenced movement of the work feed controlling follower 81. Only a general description of the feed controlling mechanism will be given here sufficient for an understanding of the present invention; a more detailed description can be had by reference to the copending United States application No.

With reference to FIG. 9 the stitch length regulator shaft 38 has a bell crank 84 secured thereto beneath the sewing machine standard 12. One arm 85 of the bell crank is blade shaped and is utilized when the controls are set for pattern cam control of the stitch length. The other arm 86 of the bell crank carries a crank pin 87 which is utilized to transmit manual control of the stitch length. A coil spring 88 attached to the bell crank 84 and anchored in the sewing machine bed serves to

bias the stitch length regulator shaft 38 in a counter-clockwise direction as viewed in FIG. 9.

For controlling the stitch length regulating shaft 38 a U-shaped bracket 89 is secured within the sewing machine standard by screws 90. The bracket 89 supports a pivot shaft 91 on which three dials or dial segments 92, 93, 94 are journaled. The dial 92, which is peripherally serrated, is formed at one side with an annular cam groove 95 which is tracked by a follower pin 96 carried on a link 97 which is bifurcated as at 98 and embraces the crank pin 87 on the stitch length regulating shaft. An anchor link 99 pivoted to the link 97 and constrained on a transverse pivot pin 100 in the bracket 89 stabilizes the link 97 so that as the dial 92 is turned the link 97 will control the stitch length regulating shaft manually for one segment of the possible positions of the dial 92, while for another segment of positions of the dial 92 the bifurcated portion of the link 97 will move out of engagement with the crank pin 87 and relinquish control over the stitch length setting. At the opposite side the dial 92 is formed a cam groove 101 which is tracked by a follower pin 102 carried on a link 103 which is pivoted by the eccentric fastening 104 to a connecting link 105. The connecting link 105 carries at one extremity an abutment pin 106 shiftable into and out of engagement with blade shaped bell crank arm 85 on the stitch length regulating shaft 38. At the other extremity the connecting link 105 is pivoted to a compound lever 107, 108 fulcrumed on the pivot pin 100 in the bracket 89. The compound lever 107, 108 is engageable at the other extremity of the limb 108 with the transmission lever 82 of the work feed controlling pattern cam follower 81. The cam grooves 95 and 101 on opposite sides of the dial 92 are related so that as the dial 92 is turned, the abutment pin 106 on the connecting link will be raised into engagement with the blade 85 as the bifurcated portion 98 of the link 97 is raised out of cooperative relation with the crank pin 87. One portion of the range of turning movement of the dial 92 thus provides for manual control of the stitch length while another portion of the range of turning movement of the dial 92 serves to render the pattern cam control of the stitch length effective.

The second dial 93 is preferably formed as a dial segment and has projecting therefrom a handle 110. The dial segment 93 is formed with a crank pin 111 arranged such that when the dial is turned in one direction, i.e., by depression of the handle 110, the crank pin will engage the anchor link 99 and provide for a quick shift of the manual stitch length regulating linkage into position for the reverse direction of work feed to the extent that the cam groove 95 in the dial 92 will allow. By virtue of a connecting link 112 pivoted at 113 to the dial segment 93 and pivoted by means of the pivot screw 114 and a clearance slot 115 to the arm 107 of the compound lever, turning movement of the dial segment 93 in a clockwise direction as viewed in FIG. 9 will serve to shift the work feed controlling pattern cam follower 81 out of engagement with any pattern cam on the cam shaft so as to facilitate exchange of cam units on the cam shaft.

The control dial 94 which is preferably serrated peripherally and which may also take the form of a dial segment, carries a crank pin 117 which is embraced by one extremity of a connecting lever 118 fulcrumed on a

pin 119 in the bracket 89. The other extremity of the connecting lever 118 embraces a crank pin 120 of an eccentric bushing 121 on the pivot pin 100. The eccentric bushing 121 provides for a micrometric adjustment of the angular relation between the arms 107 and 108 of the compound lever which transmits pattern cam information to the stitch length regulating shaft. This adjustment provides for balancing the cam influenced forward and reverse directions of feed.

With reference to FIGS. 2 and 3, the controls for the needle jogging mechanism will now be described. There is arranged in the forward portion of the bracket arm 13 four control dial segments in two spaced coaxial pairs arranged to project through the escutcheon plate 19. Of the right hand pair of dials as viewed in FIG. 3, the uppermost dial 130 influences the needle position while the lower dial 131 regulates the bight of zigzag stitching. Of the left hand pair of dials the uppermost dial 132 provides for selection of the position which the rearward pattern cam follower 59 occupies axially along the cam shaft; while the lowermost dial 133 is utilized to influence operation of the group stitch or buttonholing cam unit which may be exchangeably accommodated on the cam shaft 71 as will be described herein below.

The needle position control dial 130 and the associated control instrumentalities are illustrated in FIGS. 2, 10 and 12. The needle positioning control dial 130 is pivoted on a vertical pivot shaft 134 in the bracket arm and has pivotally connected thereto a link 135 which is pivoted in turn to a slide block 136 which is bifurcated as at 137 to embrace the vertical stud 60 and is formed with a slot 138 embracing the vertical stud 62 thus constraining this slide block to rectilinear movement transversely of the sewing machine bracket arm. The needle position controlling dial 130 is formed with four radial notches 140, 141, 142, 143, which cooperate with a spring detent 144 secured by a screw 145 to the sewing machine bracket arm thereby to designate four discrete positions of the dial 130. Corresponding to the dial positions dictated by the notches 140, 141, 142, respectively, are cam steps 150, 151, 152 on the slide block 136 which are engageable with the second cam follower 61 and serve to dictate the left, center, and right hand needle positions, respectively. When the needle position control dial 130 is shifted to the fourth discrete position as dictated by the radial notch 143, the cam follower 61 is shifted opposite a recess 153 on the slide block which recess is sufficiently deep so that it exerts no influence on the cam follower 61. The cam follower 61 is secured to a block 155 on the vertical stud 62 and an upper follower lever 156 is secured to the block 155 as by a screw 157 so that the followers 61 and 156 are journaled for turning movement and axial shifting as a unit on the vertical stud 62. A pin 158 secured in the block 155 and depending beneath the cam follower 61 is engaged by a cam surface 159 on the slide block 136 in the position of the control dial 130 as dictated by the notch 143 so as to elevate the followers 61 and 156 thus placing the follower lever 156 in this one position of the control dial 130 at an elevation in which the follower lever 156 can track a pattern cam exchangeable on the cam shaft 71. The dial 130 thus provides for one position in which the cam shaft follower 156 may track a pattern cam

and for three positions in which the needle position will be influenced by one of three predetermined positions left, center, or right as dictated by the cam surfaces 150, 151, 152, of the slide block 136.

The control dial 131 for regulating the bight of zigzag stitching is illustrated in detail in FIG. 11. The control dial 131 is also journaled on the pivot shaft 134 in the bracket arm and is formed with a projecting arm 161 carrying a depending crank pin 162. A bell crank 163 which is journaled on the cam shaft 71 is formed with a bifurcated arm 164 embracing the crank pin 162 and is formed with a second arm 165 having a spherical socket embracing the spherical stud 52 on the needle jogging control link 51. The bell crank 163 may also be formed with a third arm 166 cooperating with a stop abutment 167 on the frame to determine one extreme setting of the bight, a second stop abutment 168 may be secured to the sewing machine frame for engagement with the second arm 165 of the bell crank to limit the bight regulating motion of the bell crank 163 in the opposite direction.

The control dial 132 for selecting the position of the cam follower 59 axially along the vertical stud 60 is illustrated in FIGS. 2, 7, and 13. Threaded into the control dial 132 is a shouldered screw 170 journaled in a bracket 171 which is pivoted on the pivot shaft 134 for the dials 134 and 131. The dial 132 thus may be turned about the shouldered screw 170 or it may be shifted bodily with the bracket 171 about the pivot shaft 134. Secured on the bracket arm adjacent to the control dial 132 is an abutment bracket 172 formed with a depending tang 173 which is embraced by a system of guide slots 174 formed in the control dial 132. The guide slots 174 include three radial branches 175, 176, 177 corresponding to each of which are three notches 185, 186, and 187 in the dial 132 which cooperate with a spring detent 188 carried by the bracket 171. The tang 173 thus permits the control dial to be shifted about the axis of the pivot shaft 134 only in one of the three discrete positions determined by the notches 185, 186, and 187. The control dial 132 has pivoted thereto a cylindrical pin 190 which is slideably constrained in all block 191, made fast by a set screw 192 to a shaft 193 slideably journaled in bosses 194, 195 formed in the sewing machine bracket arm. A crank arm 196 is secured by means of a set screw to the shaft 193 and is connected by a pivot screw 198 to a blade 199 which is accommodated with a slot 200 formed in a hub portion 201 of the first pattern cam follower 59. The vertical stud 60 is formed with a series of three transverse notches 202 into which the blade 199 can enter selectively to lock the cam follower 59 in three different planes. A coil spring 203 on the shaft 193 between the boss 195 and the crank 196 biases the shaft 193 and with it the block 191 forwardly and into engagement with an annular segment 204 on the control dial 132. The spring 203 will thus bias the control dial 132 toward the left as viewed in FIG. 13 with the tang 173 locked in one of the radial branches 175, 176, 177 of the guide slot 174 and the spring 203 will also bias the blade 199 into one of the notches 202 in the vertical stud 60. To select a different position for the cam follower 59 the operator pushes in the control dial 132 shifting the tang 173 out of the radial notches 175, 176, 177 and in so doing the annular segment 204 of the

control dial acts against the block 191 to shift the shaft 193, the crank 196, and the blade 199 so as to free the blade from the notches 202. The cam follower 59 is formed with an offset and up-turned arm 205 disposed rearwardly of the crank arm 196 and depression of the control 132 simultaneously effects withdrawal of the cam follower 59 from the periphery of a cam by way of engagement of the crank arm 196 with the arm 205 of the cam follower. With the control dial 132 depressed to free the cam follower from the cam and to unlock the blade 199 from the notches 202, the control dial may be rotated about the shoulder screw 170 to turn the shaft 193 by way of the cylindrical pin 190. The rotation of the shaft 193 will turn the crank 196 to change the elevation of the blade 199 and to carry the cam follower 59 to a changed elevation along the vertical stud 60. The control dial 132 may be returned outwardly only in those positions permitted by the radial branches 175, 176, 177 of the guide slots 174 which correspond to three discrete elevations of the cam follower 59. The location of the three discrete positions for the follower 59 will be discussed in greater detail hereinbelow, and in general these positions correspond 1) one to a tracking relation with the pattern cam disk 74 fixed on the cam shaft, 2) to a position remote from any pattern cam, 3) to a position in tracking relation with a cam disk exchangeably accommodated on the cam shaft above the cam disk 74.

The fourth control dial 133, which serves to control the operation of a group stitch cam unit when such a unit is applied to the cam shaft, is rotatably supported on a pivot screw 210 threaded into a bracket 211 secured by screws 212 in the bracket arm. Since the mechanism influenced by the control dial 133 is related to the exchangeable group stitch or buttonholing cam unit, a description of this mechanism will be given following the description hereinbelow of the aforesaid group stitch pattern cam unit

Referring particularly to FIGS. 15, 16, and 17, there is fast on the cam shaft 71 above the pattern cam disk 74 an annular collar 220 upwardly from which extends a drive pin 221 arranged on an axis parallel to the axis of the cam shaft. A three armed spring 222 is constrained on the exposed upper extremity of the cam shaft above the annular collar 220 by a shouldered fastening 223 which may take the form of a shouldered screw.

The top surface of the annular collar 220 provides a reference plane for location of any one of a plurality of differently organized exchangeable pattern cam units. The drive pin 221 provides a locking means for imparting turning movement of the cam shaft 71 to the exchangeable pattern cam units, and the spring 222 serves as a retaining means holding the exchangeable pattern cam units, on the cam shaft. FIGS. 6A, 6B, and 6C illustrate three differently organized pattern cam units. The unit 224 shown in FIG. 6A includes a single pattern cam disk 225 substantially equal in outer diameter to the pattern cam disk 74. The unit 226 shown in FIG. 6B includes two pattern pattern cam disks 227 and 228 each substantially of the same overall peripheral size as the pattern cam disk 74. The pattern cam unit 229 illustrated in FIG. 6C is a group stitch forming cam unit, for instance for making buttonholes and is shown in detail in FIGS. 15, 16, and 17.

The pattern cam unit 229 includes a base portion 230 by which the pattern cam unit is secured on the cam shaft. The base portion 230 includes a flange 231 of peripheral dimension considerably smaller than that of the pattern cam disk 74 and formed with a radial notch 232 which embraces the drive pin 221 to lock the base portion rotationally with the cam shaft 71. The base portion flange extends from a hub 233 formed externally with an annular bank 234 having regularly spaced rectangular ratchet teeth 235 formed thereon. The hub is formed internally with a course thread 236 for accommodating a cap 237 and also has an annular rib 238 which cooperates with the three-armed spring 222 to retain the base portion 230 in place upon the cam shaft.

The pattern cam units 224 and 226 of FIGS. 6A and 6B are also formed each with a hub which may be constructed internally in a manner similar to that of the base portion 230 of the pattern cam unit 229 for accommodation on the cam shaft.

An annulus 240 formed externally with two pattern cam disks 241 and 242 of substantially the same outer diameter as the pattern cam 74 is formed with an axial circular aperture 243 providing a journal for the annular hub bank 234. The annulus 240 is also formed with a counterbore 244 embracing the hub flange 231. The upper face of the annulus 240 is recessed as at 245, and at diametrically opposed points, the recess 245 is formed with radial portions 246 and 247 extending to the periphery of the annulus. Projecting upwardly from the annulus in the recess 245 each radially opposite one of recess portions 246 and 247 are a pair of pivot studs 248 and 249, each pivot stud providing a fulcrum for a separate bell crank lever 250 and 251, respectively.

The bell crank lever 250 includes four radial arms, first a pawl arm 252 terminating in a rectangularly shaped pawl 253 which cooperates with the rectangular ratchet teeth 235 on the base portion 230; second, a radial arm 254 extending outwardly through the radial recess portion 246 for outside influence of the pawl 253; third, an outwardly extending radial arm 255 for manual release of the pawl as will be described hereinbelow; and fourth, an arm 256 pivotally connected to a link 257 for coupling together of the bell crank levers 250 and 251.

The bell crank lever 251 has only two arms, first a radial arm 258 pivotally connected to the link 257, and second, a radial arm 259 extending outwardly through the radial recess portion 247 for outside influence of the pawl 253.

A spring 260 is constrained in a cavity 261 in the recess 245 so as to bear against the bell crank lever 250 and to urge the pawl 253 toward the ratchet wheel teeth 235. As illustrated in FIG. 15, the outwardly extending radial arms 254 and 259 occupy different positions axially of the cam shaft 71.

Journalled on the hub 233 of the base portion 230 above the annulus 240 is a serrated knob 270 having a flange 271 which overlies the recess 245 in the annulus 240. In the underside of the flange 271 are formed elongate cavities 272 and 273 accommodating the pivot pins 248 and 249 respectively, with limited clearance for slight turning movement of the knob 270 with respect to the annulus 240. The flange 271 is also formed with a clearance slot 274 for the radial arm 259

of the bell crank 251. A pin 275 projects from the flange 271 inwardly of the cavity 272 and in a position to cooperate with the inward radial arm 255 of the bell crank 250. With this arrangement of rectangular pawl 253 and rectangular ratchet teeth 235, an advantageous result is that the pressure of the follower lever 156 on the pattern cam disk 242 cannot cause relative movement between the annulus 240 and the base portion 230 regardless of whether the follower lever is tracking an ascending or descending slope along the pattern cam disk 242. Such relative motion would be possible if pointed ratchet teeth were to be employed. By the same token, however, backward torque applied to the ratchet pawl will not cause retrogression of the pawl relatively to the ratchet wheel as is possible with pointed ratchet teeth. In order to be able to turn the annular member 240 at will, therefore, the elongated cavities 272 and 273 provide sufficient lost motion of the knob 270 that the pin 275 can engage the inward radial arm 255 of the bell crank lever 250 and shift the pawl 253 out of engagement with ratchet teeth 235 thereby freeing the annulus 240 for rotation manually by the machine operator.

Referring to FIGS. 2 and 14, the construction and operation of the control instrumentalities for the group stitch cam unit 229 as influenced by the dial 133 will now be described. The dial 133 is formed with a generally circular flange 280 having at the rear a shallow notch 281 flanked at each side by notches 282 and 283 of different depths, each however being of greater depth than the shallow notch 281. Fulcrumed on a screw 284 on the bracket 211 is a follower lever 285 having a finger 286 biased by a spring 287 to track the notches 281, 282, and 283 in the flange 280. The follower lever 258 at the extremity opposite the fulcrum screw 284 is formed with an upstanding blade 288.

Journalled in a bearing block 290 secured as by a fastening screw 291 to the vertical stud 62 is a rock shaft 292 having at one side of the block 290 a bent rock arm portion 293 engaging the blade 288, and at the other side of the block 290 having a rock arm 295 secured thereto by screws 294. A spring 296 engaging the block 290 and the bent rock arm portion 293 serves to bias the rock arm 295 in a clockwise direction as viewed in FIG. 14 thus urging the bent rock arm portion 293 into engagement with the blade 288.

The free extremity of the rock arm 295 is preferably formed with a notch 297 wider than either of the radial bell crank arms 254 or 259. Adjacent to the notch 297 the rock arm extremity is formed with a finger 298 slightly narrower than either of the radial bell crank arms 254 or 259. As shown in FIG. 14, when the dial 133 is turned so as to position the follower finger 286 in the shallow notch 281, the rock arm 295 will be elevated to a position in which the finger 298 will be disposed above both of the radial bell crank arms 254 and 259. The pawl 253 will thus be urged by the spring 260 into engagement with one of the ratchet teeth 235 and all of the parts of the cam unit 229 will be locked for rotation together. When the dial 133 is turned counterclockwise as viewed in FIGS. 2 and 14, the follower finger will shift into the notch 282 and lower the rock arms 295 to position the finger 298 into the path of the upwardly offset radial arm 259 which is the highest in elevation of the two radial arms 254, 259.

When the cam unit rotates sufficiently to bring the radial arm 259 into engagement with the finger 298, the pawl 253 will be drawn out of engagement with the ratchet teeth 235 and the pattern cam surfaces 241 and 242 of the cam unit 229 will thus be arrested. When the dial 133 is turned clockwise as viewed in FIGS. 2 and 14, the follower finger will shift first upwardly out of engagement with the radial arm 259 so as to reengage the pawl 253 in the ratchet teeth 235 and then downwardly so as to position the finger 298 on the path of the radial arm 254. The cam unit 229 will, therefore, turn one-half revolution with the cam shaft and then again be arrested. The rock arm 295 is formed with the finger 298 and with the notch 297 so that turning of the dial 133 to each side of the center position will influence the arrest of the cam unit 229 in a different predetermined position. The pattern cam disks 241 and 242 on the cam unit are formed so that each half revolution will permit the formation of a particular half of a buttonhole and it is essential for the machine operator to predict which half will be formed first in order that the buttonhole can be located accurately on the work.

OPERATION

As illustrated in FIGS. 1, 3, 4, and 5, the escutcheon plate 19 includes arched transparent covers 301, 302, which span the dial pairs 132, 133, and 130, 131 respectively on the bracket arm, and an arched transparent cover 303 which spans the feed regulating dials 92, 93 and 94 on the bracket arm. Marked on the arched transparent cover 301 is a reference line 304 which can be brought into registry with indicia 305 on the dial 132 to indicate the position of the cam follower 59. Similarly, the dial 133 carries indicia 306 which may be moved into registry with the reference line 304 to indicate the position of the rock arm 295 for controlling the clutching and declutching of the cam unit 229 to the cam shaft. The arched transparent cover 302 is formed with indicia 207 which in cooperation with a reference line 308 formed on the dial 130 serves to indicate the needle position setting. The transparent arched cover 302 is also formed with indicia 309 cooperating with a reference line 310 formed on the dial 131 to indicate the bight setting. The arched transparent cover 303 spanning the feed regulating control dials 92, 93, and 94 is formed with a reference line 311 cooperating with indicia 312 on the dial 92 to indicate the stitch length setting when the control is in the manual range and to indicate the ratio of cam movement to the stitch length which will occur in the various settings of the dial 92 in the cam control feed range. The arched transparent cover 303 is also formed with indicia 313 for the purpose of indicating that as a result of elevation of the handle 110 the cam follower 81 is removed from the exchangeable cam for facilitating exchange of cams, and as a result depression of the handle 110, the direction of feed will be reversed.

In FIG. 1 the indicia on the dials 130, 131, 132, 133 and 92 are illustrated. In FIG. 5, the dials are illustrated in a setting suitable for response of the mechanism to single pattern cam disk 224 as illustrated in FIG. 6A. The cam selection dial 132 is set so as to position the indicia depicting the replaceable pattern cam opposite the reference line 304 thus placing the pattern cam fol-

lower 59 opposite the pattern cam 225 of the single cam unit 224. The reference line 208 of the dial 130 is preferably set opposite either the left, center or right position indicia 307, and the bight control dial 131 maybe set at any desired bight setting. Then said control dial 92 is set at any desired position within the manual stitch length control range, for instance at a small length as indicated in FIG. 5.

In FIGS. 3 and 4 the dial controls of the sewing machine are indicated in settings appropriate for the start of a sewing operation for the formation of a buttonhole utilizing a buttonhole cam unit 229 of FIG. 6C. The dial 132 is adjusted to a position in which the cam follower 59 will track the plain zigzag cam 74 on the cam shaft which is indicated by the plain zigzag indicia 305 being set opposite the reference line 304. The buttonhole cam unit control dial 133 is shifted to one side preferably placing the reference line 304 opposite an indicia 307 which corresponds to indicia 314 which is imprinted on the buttonhole control unit 229 and faces the machine operator. The indicia 314 on the buttonhole control cam unit 229 and on the dial 133 correspond to discrete half revolution increments of turning movement of the buttonhole control unit 229 during which discrete halves of the buttonhole will be produced. It is only if the operator can predict which half of a buttonhole will be made that the operator can be assured of locating the resulting buttonhole accurately on a garment. When the dial 133 is shifted to the right into the position illustrated in FIG. 3, the indicium 306 having the appearance of a letter L will register with the reference line 304 and that half of a buttonhole having the appearance of the letter L will be formed i.e., barring stitches across the end of the button hole will be formed and then the side stitches at the left hand side will be made. The operator can predict, therefore, that the garment will be shifted toward the operator and the left hand side stitching will be accomplished. When the side stitching on the left hand side has been made for the desired length, the operator will turn the dial 133 in a direction to the left as viewed in FIG. 3 placing the inverted L indicium 306 opposite the reference line 304 and releasing the buttonholing cam unit 229 for another one-half revolution. In this second half revolution of the cam unit 229 the stitching as depicted on the dial 133 in the form of an inverted L will be accomplished, i.e., the barring stitches will be made at the opposite end of the buttonhole and the right hand side stitches will be made toward the operator. The right hand side stitching process is continued until these side stitches reach the previously formed barring stitches at the beginning end of the buttonhole at which time the buttonholing operation is completed.

In buttonholing operation utilizing the pattern cam unit 229, the dial 130 is turned to the position illustrated in FIG. 3, bringing the reference line 308 opposite the indicium 307 depicting a plain zigzag operation. This will position the cam follower 156 in tracking relation with the pattern cam 242 of the cam unit 229. In buttonholing operations reference line 310 of the bight dial 131 is preferably set between the numbers 2 and 3 of the indicia 309 i.e., to produce a width of side stitching slightly less than a half of the total possible width of stitching on the machine. As shown in FIG. 4, when using the buttonhole cam 229 the feed control

dial 92 is set within the cam control range, and more particularly, opposite the indicium 312 having the appearance of a stitched buttonhole is positioned opposite the reference line 311.

During the stitching of a buttonhole as described above the stitch length of the right hand side stitches as compared with the stitching length of the left hand stitches will be the result of the influence of the cam disk 241 on the feed regulating cam follower 81. Should there be any difference in the stitch length of the side stitches, this difference may be overcome by adjustment of the dial 94 which by way of the eccentric 121 will modify the transmitting linkage 107 108 of the cam controlling feed mechanism as to render the stitch length alike on both sides of the buttonhole.

Having set forth the nature of this invention, what is claimed herein is:

1. A sewing machine having a zigzag needle and a work feeding mechanism, pattern cam controllable zigzag mechanism for said needle comprising a means for controlling the bight of zigzag stitching and including a bight influencing pattern cam follower, and a means for controlling the field of zigzag stitching and including a field controlling pattern cam follower, means for controlling the stitch length and direction of feed of said work feeding mechanism and including a feed con-

trolling pattern cam follower, a cam shaft carried in said sewing machine, means for rotating said cam shaft in timed relation with the operation of said sewing machine, said cam shaft being provided with a reception seat accommodating in rotationally interlocked relation therewith, the hub portion of any selected one of a plurality of differently organized cam units including cam units having a hub and a pattern cam disk fixed on said hub, and cam units having a hub, a pattern cam disk rotatable on said hub, and a selectively operable clutch means between said cam means and said hub, certain of said cam units including one pattern cam disk disposed in a first predetermined plane perpendicular to the axis of the respective hub thereof, certain of said cam units including a second cam disposed in a second predetermined plane perpendicular to the axis of the respective hub thereof, means for positioning the bight and field influencing pattern cam followers of said zigzag mechanism selectively in tracking relation with a pattern cam disk in said first predetermined plane of a cam unit accommodated on the reception seat, and means for positioning the feed controlling pattern cam follower in tracking relation with a pattern cam disk in said second predetermined plane of a cam unit accommodated on said reception seat.

* * * * *

30

35

40

45

50

55

60

65