

FORM 1

620300 SPRUSON & FERGUSON

COMMONWEALTH OF AUSTRALIA

PATENTS ACT 1952

APPLICATION FOR A STANDARD PATENT

Pittway Corporation, incorporated in Pennsylvania, of 333 Commerce Drive, Crystal Lake, Illinois, 60014, UNITED STATES OF AMERICA, hereby apply for the grant of a standard patent for an invention entitled:

Multiple Chamber Dispensing Container and Closure System

which is described in the accompanying complete specification.

Details of basic application(s):-

<u>Basic Applic. No:</u>	<u>Country:</u>	<u>Application Date:</u>
334,071	US	6 April 1989

The address for service is:-

Spruson & Ferguson
Patent Attorneys
Level 33 St Martins Tower
31 Market Street
Sydney New South Wales Australia

DATED this THIRD day of APRIL 1990

Pittway Corporation

By:



Registered Patent Attorney

TO: THE COMMISSIONER OF PATENTS
OUR REF: 123994
S&F CODE: 53520

REPRINT OF RECEIPT
S014074 04/04/90
5845/3

COMMONWEALTH OF AUSTRALIA

PATENTS ACT 1952-66

DECLARATION IN SUPPORT OF A CONVENTION APPLICATION FOR A PATENT OR PATENT OF ADDITION

In support of the Convention Application made for a patent ~~patent of addition~~ for an invention entitled

Multiple Chamber Dispensing Container And Closure System

Full name and address of Declarant.

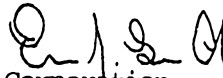
I,  (Erv J. LeCoque)
 Pittway Corporation
 of 333 Commerce Drive, Crystal Lake, Illinois 60012
 United States of America

do solemnly and sincerely declare as follows.—

1. ~~I am the applicant for the~~ patent.
~~patent of addition.~~
(or, in the case of an application by a body corporate)

1. I am authorised by Pittway Corporation the applicant for the patent ~~patent of addition~~ to make this declaration on its behalf.

Insert country and date of basic application and name of foreign applicant.

2. The basic application as defined by Section 141 of the Act was made in the United States of America on the sixth day of April 19 89 by Bruce M. Mueller.

3. ~~I am the actual inventor of the invention referred to in the basic application.~~
(or where a person other than the inventor is the applicant)

Full name and address of Inventor(s).

3. Bruce M. Mueller

of 4308 Fox Creek Drive
 Crystal Lake, Illinois 60012
 United States of America

is the actual inventor of the invention and the facts upon which the the applicant is entitled to make the application are as follows:

The said applicant is the assignee of the actual inventor.

4. The basic application referred to in paragraph 2 of this Declaration was the first application made in a Convention country in respect of the invention the subject of the application.

Declared at Crystal Lake this 10th day of April 1990.

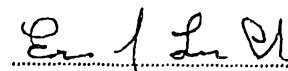
 Signature of Declarant

(12) PATENT ABRIDGMENT (11) Document No. AU-B-52913/90
(19) AUSTRALIAN PATENT OFFICE (10) Acceptance No. 620300

(Modified Examination)

- (54) Title
MULTIPLE CHAMBER DISPENSING CONTAINER AND CLOSURE SYSTEM
- International Patent Classification(s)
(51)⁵ B65D 081/32 B65D 035/22 B65D 035/38 B65D 035/44
B65D 043/16
- (21) Application No. : 52913/90 (22) Application Date : 04.04.90
- (30) Priority Data
- (31) Number (32) Date (33) Country
334071 06.04.89 US UNITED STATES OF AMERICA
- (43) Publication Date : 11.10.90
- (44) Publication Date of Accepted Application : 13.02.92
- (71) Applicant(s)
PITWAY CORPORATION
- (72) Inventor(s)
BRUCE M. MUELLER
- (74) Attorney or Agent
SPRUSON & FERGUSON , GPO Box 3898, SYDNEY NSW 2001
- (56) Prior Art Documents
US 4884703
US 4844273
DE 3514134
- (57) Claim

1. A package for dispensing at least two substances simultaneously in an adjacent relationship, said package comprising:

a container;

divider means for internally dividing the interior volume of said container into a plurality of separated storage compartments;

said container having an outlet end with a peripheral annular outlet wall defining a discharge aperture communicating with said compartments, said outlet wall having a cylindrical exterior peripheral sealing surface, and said outlet wall having interior peripheral sealing surfaces;

said divider means including at least one divider wall projecting within said discharge aperture, each said divider wall extending to said peripheral annular outlet wall to define, in cooperation with said outlet wall interior peripheral sealing surfaces, a plurality of discharge passages each communicating with a respective one of said compartments, each said divider wall having generally oppositely facing sealing surfaces that each define a portion of the inner periphery of a respective one of said discharge passages, the cooperative arrangement of each said divider wall and said outlet wall providing each said discharge passage with (1) one of said interior peripheral sealing surfaces in the form of a partially

.../2

cylindrical surface and (2) at least one planar sealing surface defined by said divider wall whereby said discharge passage has a transverse cross-sectional flow area in the form of a sector of a circle; and

a cover for securement to said container over said outlet end, said cover including (1) a downwardly projecting peripheral seal member having an interior cylindrical sealing surface for sealing against said exterior peripheral sealing surface of said container outlet wall, and (2) a plurality of downwardly projecting interior seal members, each said interior seal member including a planar seal wall and a partially cylindrical seal wall which together have a perimeter with a transverse cross-sectional shape in the form of a sector of a circle generally congruent to the flow area of the sector of one of said discharge passages, said interior seal members being arranged with the partially cylindrical seal walls located on the locus of a circle and with each said planar wall of one of said seal members being parallel to, but spaced from, a planar wall of another of said seal members whereby, when said cover is secured to said container over said outlet end, said seal members project into a respective one of said discharge passages to seal against the sealing surfaces of the outlet wall and each divider wall that define the inner periphery of said respective one discharge passage.

FORM 10

620300

Ref 123994

COMMONWEALTH OF AUSTRALIA

PATENTS ACT 1952

COMPLETE SPECIFICATION

(ORIGINAL)

FOR OFFICE USE:

Class Int Class

Complete Specification Lodged:
Accepted:
Published:

Priority:

Related Art:

Name and Address
of Applicant:

Pittway Corporation
333 Commerce Drive
Crystal Lake Illinois 60014
UNITED STATES OF AMERICA

Address for Service: Spruson & Ferguson, Patent Attorneys
Level 33 St Martins Tower, 31 Market Street
Sydney, New South Wales, 2000, Australia

Complete Specification for the invention entitled:

Multiple Chamber Dispensing Container and Closure System

The following statement is a full description of this invention, including the best method of performing it known to me/us

MULTIPLE CHAMBER DISPENSING
CONTAINER AND CLOSURE SYSTEM

TECHNICAL FIELD

5 This invention relates to a package, such as
a container and cover, from which at least two
substances can be dispensed substantially
simultaneously in an adjacent relationship.

BACKGROUND OF THE INVENTION

AND

10 TECHNICAL PROBLEMS POSED BY THE PRIOR ART

Dispensing packages, containers,
receptacles, and the like have been proposed for
dispensing two or more different substances or
materials substantially simultaneously. For example,
15 with conventional two-component epoxy adhesives, it
is necessary to keep both components separated until
used. However, it is desirable to be able to
dispense both components simultaneously from the same
receptacle in proportionally established amounts so
20 that they can be subsequently used.

With some types of materials, it is
important to seal the supply of materials within the
receptacle when the materials are not being
dispensed. For example, with some materials it may
25 be necessary to avoid prolonged exposure to air, and
with other materials it may be necessary to store the
materials in the receptacle in a sanitary manner that
prevents the ingress of contaminants.

Thus, it would be desirable to provide an
30 improved package of the above-described type which
would have an improved sealing capability.

Further, it would be beneficial if such an
improved package could be provided with an easily
operated cover or closure mechanism that could be
35 mounted to, or otherwise integrated with, the

container in which the substances are stored.

5 Additionally, it would be advantageous if the design of such an improved package would permit relatively easy fabrication from relatively low cost materials.

SUMMARY OF THE INVENTION

10 A package is provided for dispensing at least two substances simultaneously in an adjacent relationship. The package includes a container having a plurality of separated storage chambers or compartments. The container has an outlet end with a peripheral outlet wall and at least one interior divider wall cooperating to define a plurality of discharge passages which each communicate with a
15 respective one of the compartments.

The container outlet wall has interior peripheral sealing surfaces that each define a portion of the inner periphery of a respective one of the discharge passages. Each divider wall has
20 generally oppositely facing sealing surfaces that each define a portion of the inner periphery of a respective one of the discharge passages.

The package also includes a cover for securement to the container over the outlet end. The
25 cover includes at least a plurality of downwardly projecting interior seal members for each projecting into a respective one of the discharge passages to seal against the sealing surfaces of the divider wall and outlet wall that together define the inner
30 periphery of the respective one discharge passage.

Numerous other advantages and features of the present invention will become readily apparent from the following detailed description of the invention, from the claims, and from the accompanying
35 drawings.

BRIEF DESCRIPTION OF THE DRAWINGS

In the accompanying drawings forming a part of the specification, in which like numerals are employed to designate like parts throughout the same,

5 FIG. 1 is a perspective view of a first embodiment of the package of the present invention shown with the cover in the full open position;

 FIG. 2 is a greatly enlarged, fragmentary, top plan view of the package illustrated in FIG. 1;

10 FIG. 3 is a fragmentary, cross-sectional view taken generally along the plane 3-3 in FIG. 2;

 FIG. 4 is a cross-sectional view taken generally along the plane 4-4 in FIG. 3;

15 FIG. 5 is a view similar to FIG. 3, but showing the cover in the closed position;

 FIG. 6 is a cross-sectional view taken generally along the plane 6-6 in FIG. 5;

20 FIG. 7 is a top plan view of an open closure which may be mounted on a receptacle as a second embodiment of the present invention; and

 FIG. 8 is a top plan view of an open closure which may be mounted on a receptacle as a third embodiment of the present invention.

DESCRIPTION OF THE PREFERRED EMBODIMENTS

25 While this invention is susceptible of embodiment in many different forms, this specification and the accompanying drawings disclose only some specific forms as examples of the use of the invention. The invention is not intended to be limited to the embodiment so described, and the scope of the invention will be pointed out in the appended claims.

35 For ease of description, the article of this invention is described in upright position, and terms such as upper, lower, horizontal, etc. are used with

reference to this position. It will be understood, however, that the article of this invention may be manufactured, stored, transported, used, and sold in an orientation other than the position described.

5 A first embodiment of a package in accordance with the teachings of the present invention is designated generally in FIG. 1 by the reference numeral 10. The package 10 includes a container 12. The container 12 is preferably of the
10 type that is easily squeezable, compressible, and/or collapsible.

 The container 12 is preferably fabricated from a suitable material that permits the container to be at least temporarily squeezed or compressed.
15 For example, the container 12 may have the form of a tube as illustrated and may be readily extruded from an appropriate synthetic plastic material, such as polyvinyl or polyethylene. On the other hand, the container 12 may be fabricated from other materials,
20 such as thin metal, for example, aluminum, tin, lead, or the like. Container 12 could also be a blow-molded container.

 The container 12 is divided into separated storage compartments by a divider wall 16 (FIGS. 1, 3, 5, and 6). Depending upon the construction of the container 12, the divider wall 16 may be integrally formed as a unitary part of the container 12.
25 Alternatively, the divider wall 16 may be a separately formed, plate-like member appropriately retained in the container 12.
30

 In the embodiment illustrated, the container 12 comprises two identical halves which are appropriately joined together in conjunction with the divider wall 16. In particular, when the container
35 12 and divider wall 16 are fabricated from a

thermoplastic material, heat sealing may be used to join the two halves of the container 12 together with the divider wall 16 along the peripheral margins of the divider wall 16. To this end, each half of the container 12 can be provided with an inner recess 20 set back from the mating plane. The peripheral edges of the divider wall 16 are held in the recesses 20 of each half of the container 12, and this construction is permanently maintained by a suitable thermal fusion bond or adhesive bond.

The bottom of the container 12 may have any suitable configuration. In the embodiment illustrated in FIG. 1, the bottom of the container 12 is crimped or squeezed together with the walls of the container 12 being adhesively or thermally bonded together and to the internal divider wall 16. The bottom margin of the divider wall 16 is received in appropriate recesses at the bottoms of the container walls in a manner analogous to the use of the recesses 20 illustrated in FIG. 3 for accommodating the peripheral side margins of the divider wall 16.

With reference to FIG. 3, the container 12 has a generally cylindrical neck 26 defining an open end 28. The container 12 is adapted to be closed by a cover 64. In the preferred embodiment illustrated in FIGS. 1-6, the cover 64 is attached to a cover base 30 which in turn is mounted on the container neck 26 and which defines a peripheral outlet wall 32.

The cover base 30 includes a generally cylindrical skirt 34 which may be either releasably or permanently retained on the exterior of the container tube neck 26. To this end, the exterior surface of the neck 26 may be provided with an annular concave groove 38, and the inner surface of



the skirt 34 may be provided with an inwardly projecting, annular protuberance, bead, or ring 40 for being engaged in the groove 38. This provides a conventional groove and bead snap-fit engagement.

5 The cover base 30 could also be permanently attached with adhesive, ultrasonic or radiofrequency welding, or the like, by bonding the skirt 34 to the neck 26.

The cover base 34 can be mounted on the container neck 26 by pushing the cover base 30
10 downwardly so that the skirt 34 slides over the container neck 26 until the skirt bead 40 snaps into the container neck groove 38.

In the embodiment illustrated in FIG. 3, a reduced-width portion of the divider wall 16 extends
15 upwardly beyond the top of the container neck 26. The cover base peripheral outlet wall 32 has a reduced diameter annular configuration extending upwardly from the skirt 34 and has a diameter that is somewhat less than the width of the projecting
20 portion of the divider wall 16. The cover base outlet wall 32 defines vertical grooves 44 (FIGS. 2 and 3) for receiving the peripheral margins of the divider wall 16. Within the cover base outlet wall 32, the divider wall 16 has oppositely facing sealing
25 surfaces 56 as best illustrated in FIGS. 2 and 6.

The cover base outlet wall 32 has interior peripheral sealing surfaces 48 (FIGS. 2 and 6) and has an exterior peripheral sealing surface 50 (FIGS. 2 and 6). The outlet wall 32 terminates in a distal
30 end surface 52 above the sealing surfaces 48 and 50 (FIG. 6).

It will be appreciated, with reference to FIG. 2, that the peripheral outlet wall 32 and the divider wall 16 cooperate to define a plurality of
35 discharge passages each communicating with a

respective one of the storage compartments in the container 12. A portion of the inner periphery of each discharge passage is defined by the sealing surface 56 at the upper end of the divider wall 16.

5 Also, the interior peripheral sealing surface 48 of the outlet wall 32 defines a portion of the inner periphery of the discharge passage.

Although the cover base 30 is illustrated as a separate component in the preferred embodiments
10 illustrated in the Figures, it is to be realized that the container 12 may include a unitary cover base at its upper end with a configuration similar to that shown for the separate cover base 34. That is, a unitary upper end of the container 12 would be
15 configured to directly receive the cover 64. Alternatively, other suitable configurations may be provided at the upper end of the container 12, with or without a separate closure base component.

In the preferred embodiment illustrated in
20 FIG. 1-6, the cover 64 is connected to the cover base 30 via a snap-action hinge that may be of a conventional molded plastic design which includes two spaced-apart main bend film hinges 66 (FIGS. 2 and 3) and an offset connecting spring link 68. One end of
25 the link 68 is connected to the cover 64 via a film hinge 70 and the other end is connected to the cover base skirt 34 via a film hinge 72.

The above-described snap-action hinge structure permits the cover 64 to be moved between
30 the open and closed positions because the link 68 deforms elastically through a dead center position at which the link 68 is maximally deformed. On either side of the dead center position, the deformation of the link 68 is at least partly reduced, and the cover
35 64 is thus urged to a stable position at the end of

its travel range on that side of the dead center position. In this manner, when the cover 64 is closed (FIG. 5), it is self-maintained in the closed position. On the other hand, when the cover 64 is open (FIG. 3), it is self-maintained in that position to accommodate ^{dispensing} ~~dispensing~~ of the contents without having to use one's fingers to hold the cover out of the way.

Although the preferred embodiment is illustrated in FIGS. 1-6 with the cover 64 attached to the cover base 30, it will be appreciated that the cover 64 may be connected directly to the top of the container 12. In that case, the top of the container 12 would have an appropriate configuration which may be similar to the configuration of the illustrated cover base 30.

Further, in another form of the invention, the cover 64 need not be connected to the cover base 30 or to the container 12, and would be completely removable from the container 12. However, in the preferred form of the invention, the cover 64 is connected, preferably with the illustrated snap-hinge, to the container 12 (or to the cover base 34 mounted on the container 12 as illustrated) so as to provide a convenient, complete package 10 in which the cover 64 is always associated with the package 10, even when the package 10 is open.

The cover 64 includes a plurality of downwardly projecting interior seal members 80 (FIG. 2) which are adapted to project into a respective one of the container discharge passages when the cover 64 is closed (as illustrated in FIGS. 5 and 6) so as to seal against the divider wall 16 and against the interior peripheral sealing surfaces 48 that define the inner periphery of the discharge passages.



As can be seen in the plan view in FIG. 2, each cover seal member 80 is a generally hollow member having an open end with an axial cross-sectional shape in the form of a sector of a circle which is generally congruent to the sector defined by the discharge passage of the container outlet.

The two seal members 80 are spaced apart by an amount sufficient to receive the upper peripheral edge of the divider wall 16 in sealing engagement as best illustrated in FIG. 6. The exterior, semi-circular arc surface of each seal member 80 seals against the interior peripheral sealing surface 48 of the associated discharge passage of the container 12. To facilitate insertion of each seal member 80 into the associated discharge passage, each seal member 80 is defined by flexible, projecting seal walls which have curved distal ends 84 as best illustrated in FIGS. 3 and 4.

In the preferred form of the invention illustrated in FIGS. 1-6, the cover 64 further includes a projecting peripheral seal member 90. The seal member 90 has the configuration of an axially projecting annular wall which is adapted to circumferentially engage the exterior peripheral sealing surface 50 of the cover base peripheral wall 32 when the cover 64 is closed as best illustrated in FIGS. 5 and 6.

The container 12 of the package 10 may be continuously extruded in a tube configuration and then end-sealed or may be individually molded. The outlet end of the tube may be a post-formed extrusion or may be molded. The container can be provided with a molded dispensing closure which includes the cover base and cover or lid.

The package 10 of the present invention permits separated substances to be simultaneously dispensed from a single container to give a generally precise, pre-established flow-mix ratio. Thus, the dispensing of the substances can be relatively easily and precisely controlled. This is especially useful for substances which must be separated until they are to be mixed and which are difficult to otherwise dispense and mix correctly.

An alternate embodiment of the present invention is illustrated in FIG. 7 wherein a cover base 30' is provided with a hingedly attached cover 64'. The base 30' may be mounted to a suitable container (not illustrated). Alternatively, the cover base 30' may be formed as an integral part of the upper end of the container.

In any case, the cover base 30' has a peripheral outlet wall 32'. A divider means is provided in the form of a plurality of divider walls 16' which extend to the outlet wall 32' radially from a central point to define the axial cross-sectional shape of each discharge passage as the sector of a circle. In the embodiment illustrated in FIG. 7, three such divider walls 16' are arranged uniformly to define three 120 degree angles.

The cover 64' includes three hollow seal members 80'. Each hollow member 80' has an open end and has an axial cross-sectional shape in the form of a sector generally congruent to the sector of a respective one of the discharge passages defined by a pair of the divider walls 16' and peripheral arc of the outlet wall 32'.

A third embodiment of the present invention is illustrated in FIG. 8 and is substantially similar to the second embodiment illustrated in FIG. 7 except

that a cover base 30'' has an outlet wall 32'' which cooperates with four divider walls 16'' arranged uniformly to define four 90 degree angles. A cover 64'' is provided with mating hollow seal members 80'' which each have a configuration of a sector of a circle. The sector shape of each seal member 80'' is generally congruent to the sector of an associated discharge passage defined by a pair of the divider walls 16'' and the circular arc of the outlet wall 32''.

In the embodiments illustrated in FIGS. 7 and 8, the divider walls 16' or 16'' may be characterized as extending radially from a central point to the peripheral outlet wall 32' or 32''. The first embodiment illustrated in FIGS. 1-6 may be analogously characterized. Specifically, with reference to the plan view of FIG. 2, the single divider wall 16 may be characterized as "two" divider walls each extending from a central point in opposite directions in a common vertical plane.

The divider walls in all of the embodiments, divider walls 16, 16' and 16'', may be integrally molded with the container or cover base or may be fabricated as separate components for being received between appropriately configured wall portions of the container. To this end, the particular arrangement of the grooves 44 in the outlet wall 32 and of the recesses 20 in the container wall sections for accommodating the divider wall 16 in the first embodiment illustrated in FIGS. 1-6 may be adapted for the three divider walls 16' or four divider walls 16'' of the second and third embodiments illustrated in FIGS. 7 and 8, respectively.

Of course, it will be understood that the use of the alternate embodiment structures

illustrated in FIGS. 7 and 8 contemplate use with a container having a plurality of separate storage compartments corresponding to the multiple discharge passages between the divider walls (16' or 16''). To
5 this end, the container for use with the embodiment illustrated in FIG. 7 would have three divider walls and three storage compartments while the container for use the embodiment illustrated in FIG. 8 would have four divider walls and four storage compartments.

10 With any of the embodiments of the present invention, it will be recognized that the cover sealing members (e.g., sealing members 80 in the first embodiment illustrated in FIGS. 1-6), seal inwardly of the distal end of the opening and seal
15 for some distance along the longitudinal (vertical) surfaces inwardly of the opening. This ensures that the substances within the container are properly sealed from the ambient atmosphere. This also ensures that the substances are kept separated within
20 the container and cannot come into contact with each other in the outlet area of the container adjacent the cover 64. This is especially important when the container is used for substances which might be different reactive components that, when combined,
25 chemically react.

It will also be appreciated that the present invention permits the container to be provided with a plurality of separate compartments and to be provided with an outlet end that readily accepts a fitment or
30 cover base which easily aligns with, and which is readily retained on, the container.

Further, when the cover is provided with a unitary attachment to the container or to the cover base mounted on the container, the cover is easily
35 aligned for closure of the container. This ensures

proper alignment of the cover sealing members (e.g., sealing members 80 and 90 in FIGS. 1, 5, and 6) with the associated discharge passages and peripheral outlet wall.

5 Further, the novel features of the present invention accommodate the use of a separate fitment or cover with base which may be mounted to the container with a snap-on engagement. Alternatively, a threaded engagement could also be accommodated.

10 Finally, the novel package of the present invention permits the container to be fabricated as a tube with a crimped or sealed, flat end. It also accommodates the use of a container having a flat bottom, such as a circular, flat bottom in a
15 cylindrical container or a square or rectangular flat bottom in a container with generally flat sides.

 It will be readily observed from the foregoing detailed description and from the illustrated embodiments thereof that numerous
20 variations and modifications may be effected without departing from the true spirit and scope of the novel concepts or principles of this invention.

25

30

35

The claims defining the invention are as follows:

1. A package for dispensing at least two substances simultaneously in an adjacent relationship, said package comprising:

a container;

divider means for internally dividing the interior volume of said container into a plurality of separated storage compartments;

said container having an outlet end with a peripheral annular outlet wall defining a discharge aperture communicating with said compartments, said outlet wall having a cylindrical exterior peripheral sealing surface, and said outlet wall having interior peripheral sealing surfaces;

said divide means including at least one divider wall projecting within said discharge aperture, each said divider wall extending to said peripheral annular outlet wall to define, in cooperation with said outlet wall interior peripheral sealing surfaces, a plurality of discharge passages each communicating with a respective one of said compartments, each said divider wall having generally oppositely facing sealing surfaces that each define a portion of the inner periphery of a respective one of said discharge passages, the cooperative arrangement of each said divider wall and said outlet wall providing each said discharge passage with (1) one of said interior peripheral sealing surfaces in the form of a partially cylindrical surface and (2) at least one planar sealing surface defined by said divide wall whereby said discharge passage has a transverse cross-sectional flow area in the form of a sector of a circle; and

a cover for securement to said container over said outlet end, said cover including (1) a downwardly projecting peripheral seal member having an interior cylindrical sealing surface for sealing against said exterior peripheral sealing surface of said container outlet wall, and (2) a plurality of downwardly projecting interior seal members, each said interior seal member including a planar seal wall and a partially cylindrical seal wall which together have a perimeter with a transverse cross-sectional shape in the form of a sector of a circle generally congruent to the flow area of the sector of one of said discharge passages, said interior seal members being arranged with the partially cylindrical seal walls located on the locus of a circle and with each said planar wall of one of said seal members being parallel to, but spaced from, a planar

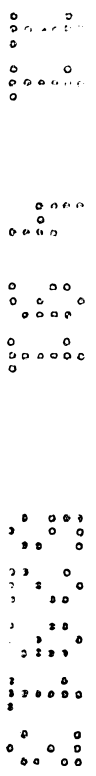

wall of another of said seal members whereby, when said cover is secured to said container over said outlet end, said seal members project into a respective one of said discharge passages to seal against the sealing surfaces of the outlet wall and each divider wall that define the inner periphery of said respective one discharge passage.

2. The package in accordance with claim 1 in which said outlet wall terminates in a distal end surface above said exterior and interior peripheral sealing surfaces; and

said package includes a plurality of said divider walls and each said divider wall terminates in a distal end surface above said oppositely facing sealing surfaces.

3. The package in accordance with claim 2 in which said distal end surfaces of said divider walls and outlet wall lie in a common plane.

4. The package in accordance with claim 1 in which said container includes an open ended tube;

said container outlet end includes a cover base mounted on said tube to define said container peripheral annular outlet wall; and

said package further includes a hinge means for hingedly connecting said cover to said cover base for movement between (1) a closed position in which said cover seal members are in sealing engagement with said container outlet end sealing surfaces, and (2) an open position sealingly disengaged from said container outlet end sealing surfaces to permit dispensing of said substances from said discharge apertures.

5. The package in accordance with claim 4 in which said tube includes a generally cylindrical neck defining an open end; and

said cover base includes (1) a generally cylindrical skirt for being releasably retained on the exterior of said tube neck, and (2) a reduced diameter annular wall extending upwardly from said skirt to define said container peripheral annular outlet wall, said annular wall defining interior axially oriented grooves for receiving margins of said divider walls.

6. The package in accordance with claim 1 in which said outlet end of said container is defined by a reduced diameter portion at the top of said container; and

said container includes a collapsible dispensing portion extending from said reduced diameter portion.



7. The package in accordance with claim 1 in which each said cover seal member is a hollow member having an open end.

8. The package in accordance with claim 1 in which said divider means includes three of said divider walls arranged uniformly to define three 120 degree angles.

9. The package in accordance with claim 1 in which said divider means includes four of said divider walls arranged uniformly to define four 90 degree angles.

10. The package in accordance with claim 1 in which said divider means includes two of said divider walls each extending from said central point in opposite directions in a common vertical plane to define a single, unitary, planar wall structure.

11. The package in accordance with claim 1 in which each said seal member is defined by projecting seal walls which have curved distal ends for facilitating insertion of each said seal member into a respective one of said discharge passages.

12. A package for dispensing at least two substances simultaneously in an adjacent relationship, said package comprising:

a container having a plurality of separated storage compartments, said container including a tube having a generally cylindrical neck defining an open outlet end and a cover base mounted on said tube neck, said cover base including (1) a generally cylindrical skirt for being retained on the exterior of said tube neck, and (2) a peripheral outlet wall extending upwardly from said skirt;

said container having at least one interior divider wall extending at least from said compartments into said cover base and cooperating to define a plurality of discharge passages which each communicate with a respective one of said compartments, said cover base outlet wall defining interior axially oriented grooves for each receiving a margin of one of said divider walls in sealing engagement, said cover base outlet wall further having interior peripheral sealing surfaces that are located between said grooves and that each define a portion of the inner periphery of a respective one of said discharge passages, each said divider wall having generally oppositely facing sealing surfaces that each define a portion of the inner periphery of a respective one of said discharge passages; and

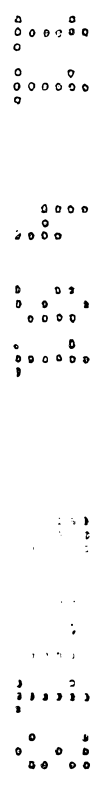

a cover for being releasably secured to said cover base at said tube outlet end, said cover including at least a plurality of downwardly projecting interior seal members or each projecting into a respective one of said discharge passages to seal against the sealing surfaces of the divider wall and cover base outlet wall that define the inner periphery of said respective one discharge passage.

13. The package in accordance with claim 12 in which each said divider wall extends to said peripheral outlet wall to define the axial cross-sectional shape of each said discharge passage as a sector of a circle; and

each said cover seal member is a hollow member having an open end and having an axial cross-sectional shape in the form of a sector generally congruent to the sector defined by a respective one of said discharge passages.

14. The package in accordance with claim 13 in which said package includes three of said divider walls arranged uniformly to define three 120 degree angles.

15. The package in accordance with claim 13 in which said package includes four of said divider walls arranged uniformly to define four 90 degree angles.

16. The package in accordance with claim 13 in which said package includes two of said divider walls each extending from said central point in opposite directions in a common vertical plane to define a single, unitary, planar wall structure.

17. The package in accordance with claim 13 in which each said hollow seal member is defined by flexible projecting seal walls which have curved distal ends for facilitating insertion of each said seal member into a respective one of said discharge passages.

18. The package in accordance with claim 12 in which said tube and cover base include means for releasably retaining said cover base on said tube;

said cover base outlet wall has an exterior peripheral sealing surface; and

said cover further includes downwardly projecting peripheral seal member for sealing against said exterior peripheral sealing surface of said cover base outlet wall.



19. The package in accordance with claim 12 in which said package includes a plurality of said divider walls; said divider walls extend throughout the length of said container interior to define said plurality of separated compartments; said cover base outlet wall is annular and terminates in a distal end surface above said interior peripheral sealing surfaces; and said oppositely facing sealing surface of each said divider wall are generally planar and each said divider wall terminates in a distal end surface above said oppositely facing sealing surfaces.

20. The package in accordance with claim 12 in which said container includes a tube having a generally cylindrical neck defining an open end; and said container outlet end includes a cover base mounted on said tube neck to define said peripheral outlet wall, said cover base including (1) a generally cylindrical skirt for being releasably retained on the exterior of said tube neck, and (2) a reduced diameter annular wall extending upwardly from said skirt to define said container peripheral outlet wall, said annular wall defining interior axially oriented grooves for receiving margins of said divider wall.

DATED this TENTH day of APRIL 1991

Pittway Corporation

Patent Attorneys for the Applicant
SPRUSON & FERGUSON



RLF/0327p

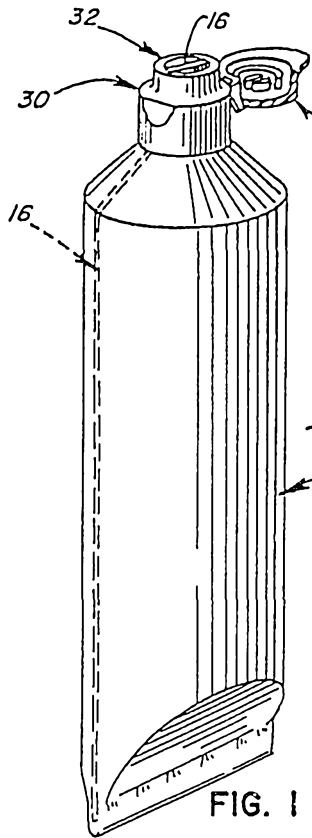

FIG. 1

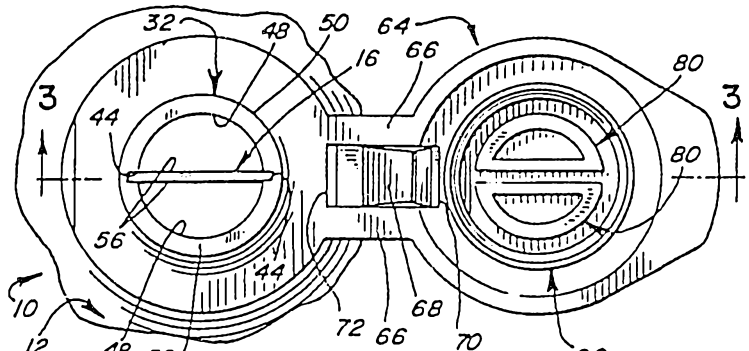

FIG. 2

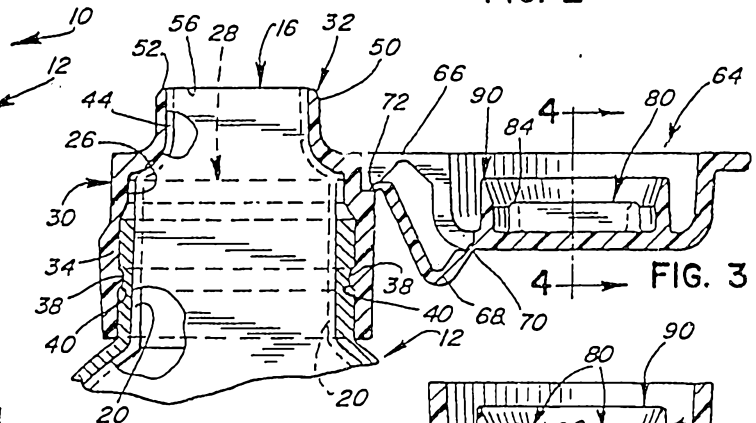

FIG. 3

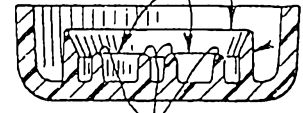

FIG. 4

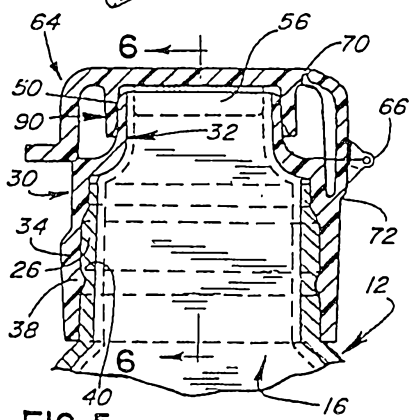

FIG. 5

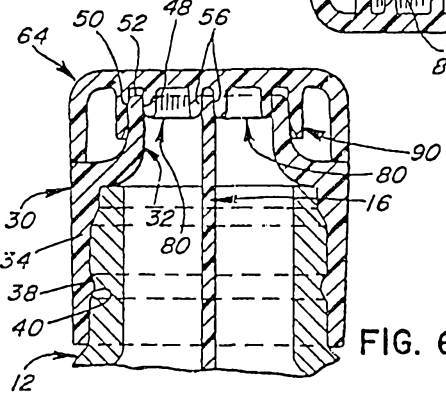

FIG. 6

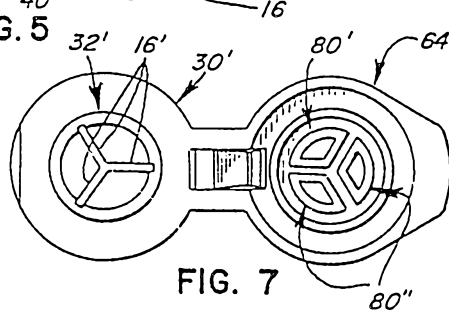

FIG. 7

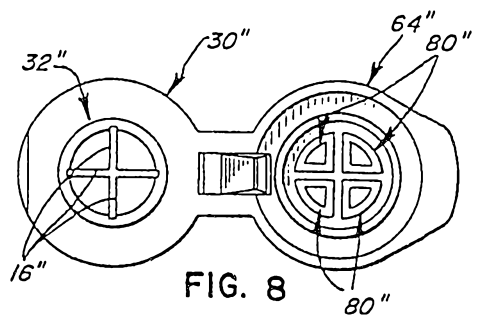

FIG. 8