

No. 846,958.

PATENTED MAR. 12, 1907.

S. B. SHELDON.
PROCESS OF COKING COAL.
APPLICATION FILED JAN. 2, 1907.

5 SHEETS—SHEET 1.

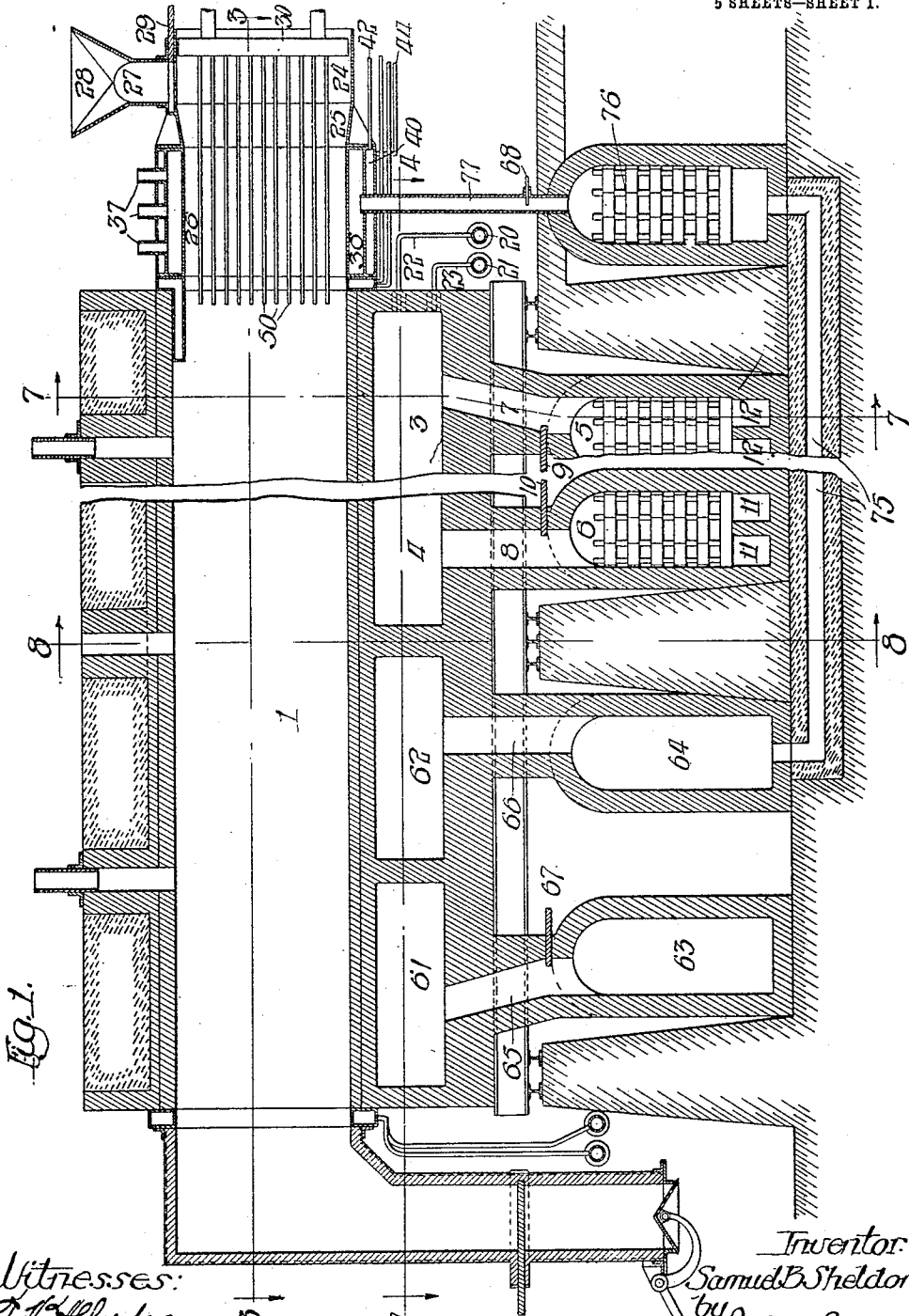

Witnesses:
J. H. Glude
S. D. Hirschl.

Inventor:
Samuel B. Sheldon
by
Wooler & Brown
Attys.

S. B. SHELDON.
PROCESS OF COKING COAL.
APPLICATION FILED JAN. 2, 1907.

5 SHEETS—SHEET 2.

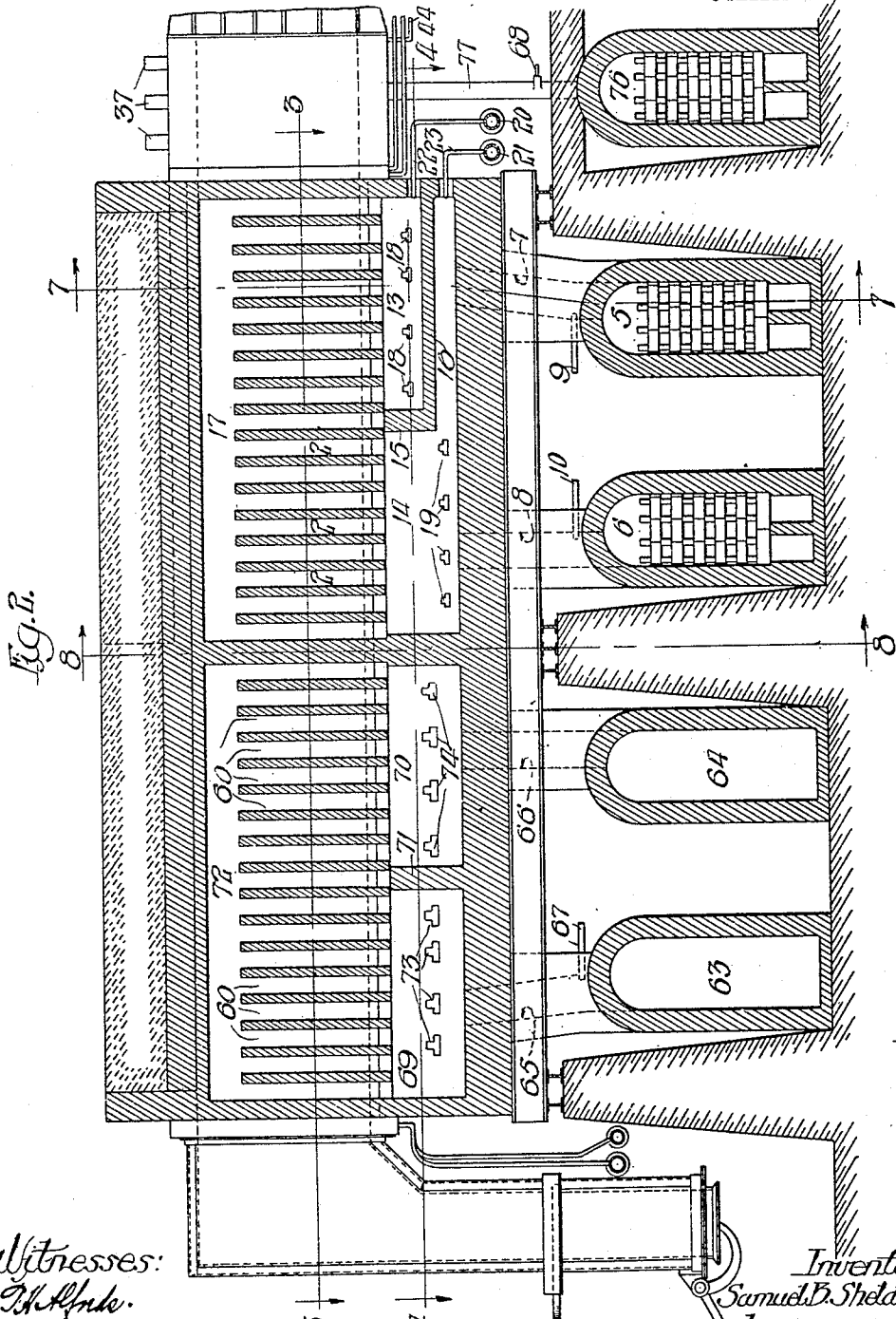

Witnesses:
S. D. Hirschl.

Inventor
Samuel B. Sheldon
By *Pooler & Moore*
Attys.

No. 846,958.

PATENTED MAR. 12, 1907.

S. B. SHELDON.
PROCESS OF COKING COAL.

APPLICATION FILED JAN. 2, 1907.

5 SHEETS—SHEET 3.

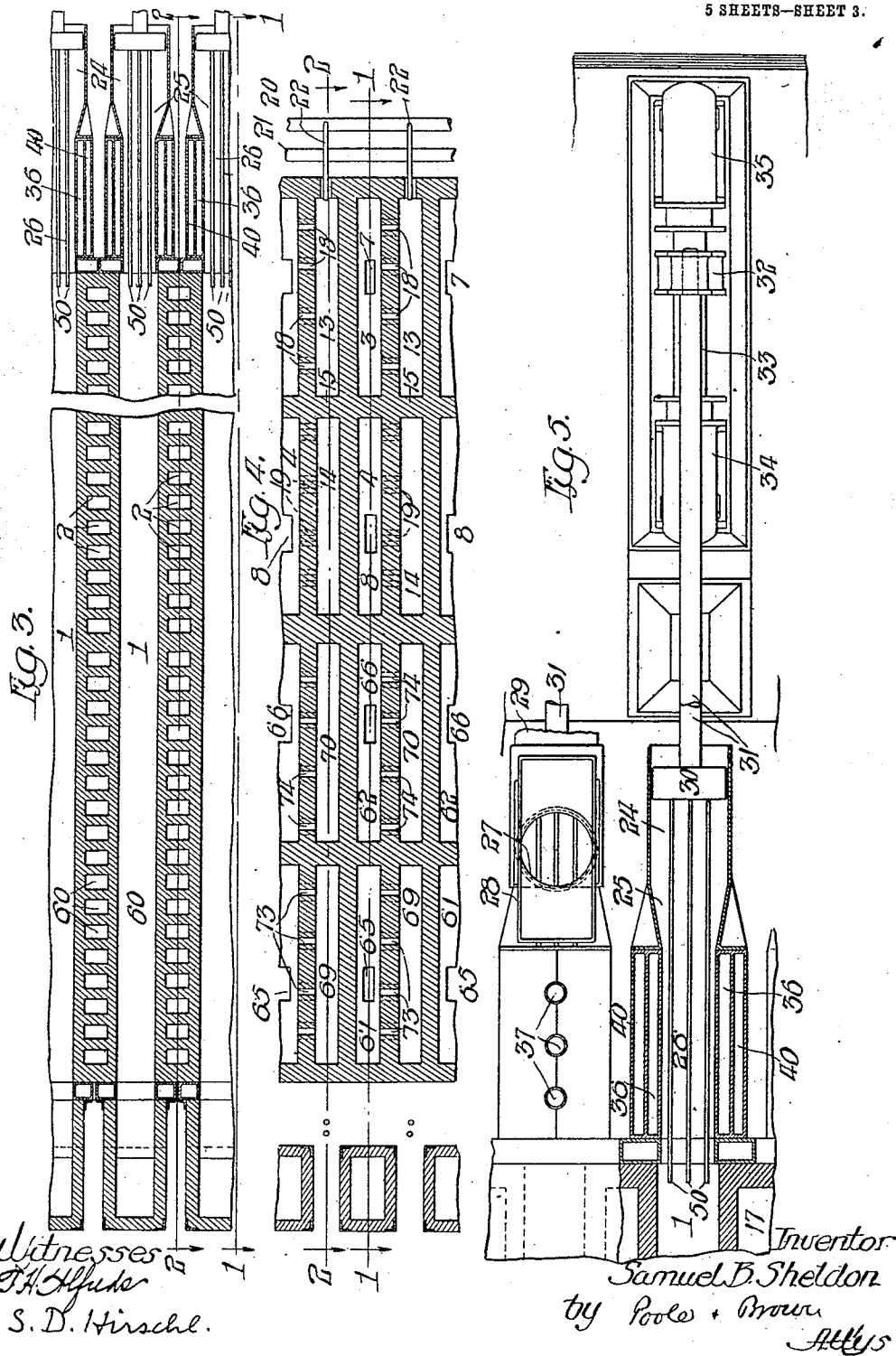

No. 846,958.

PATENTED MAR. 12, 1907.

S. B. SHELDON.
PROCESS OF COKING COAL.
APPLICATION FILED JAN. 2, 1907.

5 SHEETS—SHEET 4.

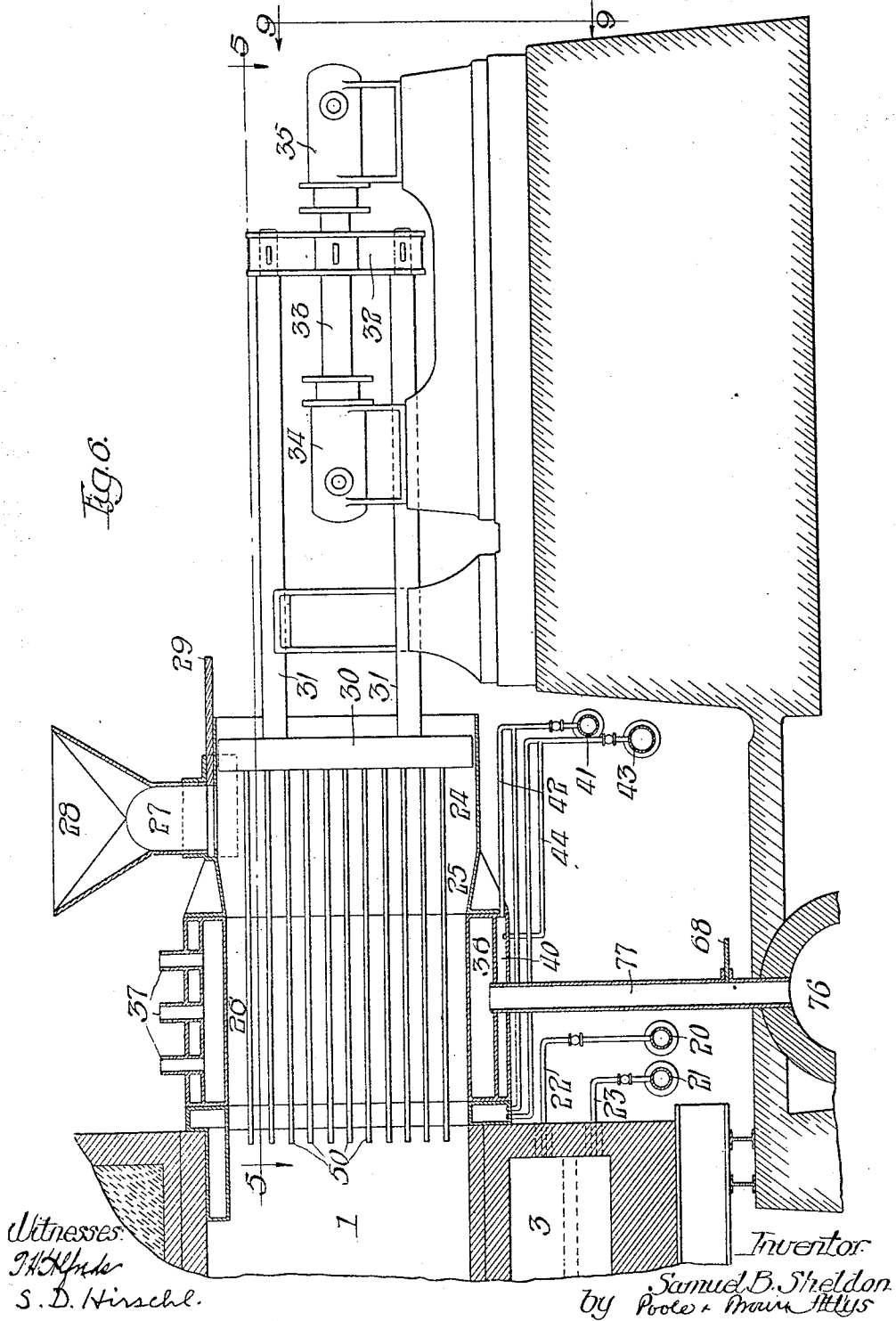

No. 846,958.

PATENTED MAR. 12, 1907.

S. B. SHELDON.
PROCESS OF COKING COAL.
APPLICATION FILED JAN. 2, 1907.

5 SHEETS—SHEET 5.

Fig. 9.

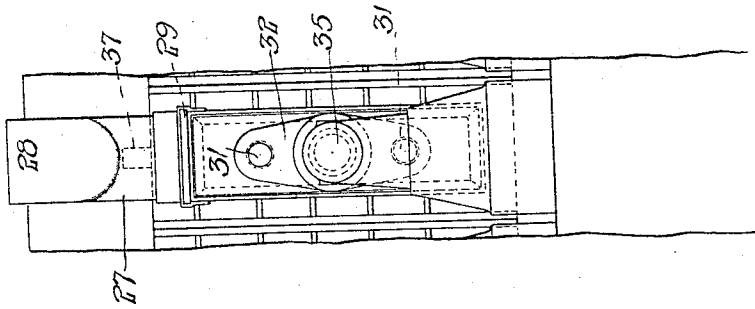

Fig. 8.

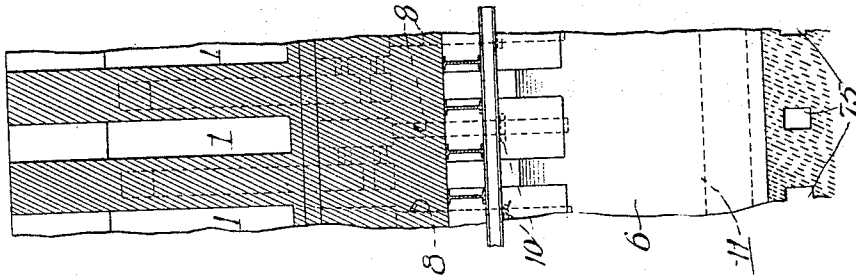
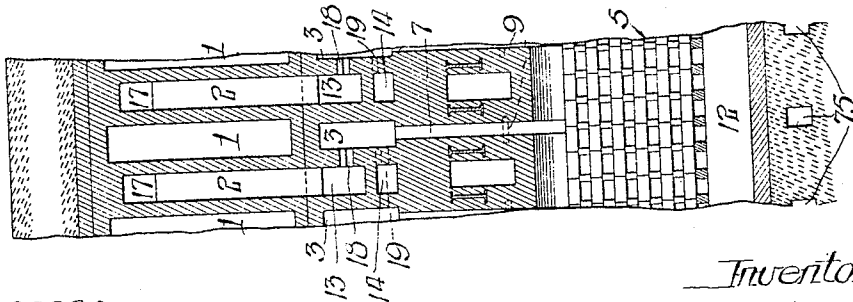

Fig. 7.



Witnesses:
G. H. Hedges
S. D. Hirschel.

Inventor:
Samuel B. Sheldon
by *Pooler & Brown*
Attys.

UNITED STATES PATENT OFFICE.

SAMUEL B. SHELDON, OF BUFFALO, NEW YORK.

PROCESS OF COKING COAL.

No. 846,958.

Specification of Letters Patent.

Patented March 12, 1907.

Application filed January 2, 1907. Serial No. 350,409.

To all whom it may concern:

Be it known that I, SAMUEL B. SHELDON, a citizen of the United States, and a resident of Buffalo, in the county of Erie and State of New York, have invented certain new and useful Improvements in Processes of Coking Coal; and I do hereby declare that the following is a full, clear, and exact description thereof, reference being had to the accompanying drawings, and to the letters of reference marked thereon, which form a part of this specification.

This invention relates to improvements in the art of coking or distilling coal for the manufacture of coke and the production of gas, and more especially to a process by which is saved or utilized the heat which remains in the coke at the end of the coking operation and which is ordinarily wasted.

An apparatus is illustrated in the accompanying drawings for carrying out the novel process constituting my invention. Said apparatus embraces general features of construction as follows: For effecting the coking or distillation of the coal a coking-oven is employed of the kind described in my prior application for United States Letters Patent, filed April 21, 1906, Serial No. 313,072; but my invention may be carried out by the use of furnaces of other types. I have shown in the drawings and prefer to use the type of oven commonly known as the "Otto Hoffman" oven, in which the coking-chamber is arranged horizontally or is horizontally elongated and is adapted for the introduction of coal at one end thereof and the discharge of coke from the opposite end thereof, the coal during the coking operation being advanced along or through the oven and said oven being closed against access of outside air and provided with delivery ducts or passages, through which pass the gases produced during the coking operation. The oven illustrated, moreover, consists of two parts or sections arranged end to end to form a continuous coking-chamber, the first of said sections, or the one adjacent to the receiving end of the oven, being provided with heating means and the section adjacent to the discharge end of said oven being provided with cooling means, embracing air-flues in the walls of the oven, through which air is circulated to absorb or abstract the heat from the coke, as will be hereinafter more specifically described. In connection with said oven at the receiving end thereof

are located means for forcing the coal into and through the oven, means for compressing the coal preparatory to its introduction into the oven, and means for preheating the coal after it is compressed and before it enters the oven. The coal feeding, compressing, and preheating means embrace generally a receiving-chamber, a preheating-chamber, and a tapered passage connecting said receiving and preheating-chambers, which is larger at its receiving than at its delivery end. The said receiving-chamber, the tapered passage, and the preheating-chamber are connected with each other, so as to constitute a continuous passage, which at the delivery end of the preheating-chamber opens into the receiving end of the oven. The receiving-chamber is provided at its top with an opening through which the coal, preferably in pulverized form, may be introduced into said chamber, and in said receiving-chamber is located a horizontally-reciprocating plunger operating in its advance movements to force the charges of coal introduced into the chamber at the front of said plunger through said tapered passage and the preheating-chamber into the coking-chamber. The tapered sides of the said passage constitute, in connection with said plunger, the means for compressing the coal, the inclined or tapered sides of said passage serving to effect compression of the coal laterally or from the outside toward the center of the mass of coal as the latter is forced through said passage by the action of the plunger. The walls of the preheating-chamber are preferably made of relatively thin metal and are surrounded by a circulating-chamber adapted to receive heated air, said heated air being that which has been heated by circulation through the air-flues of the above-mentioned cooling-section of the oven, the heat derived from the coke in cooling the latter being transmitted through the said metal walls to the mass of coal within the preheating-chamber. The compacted mass of coal which enters the preheating-chamber from the said tapered passage in which it is compressed is subjected in its passage through the preheating-chamber to any desired degree of heat. Within said passage formed by the receiving-chamber, the tapered passage, and the preheating-chamber are located a series of metal rods arranged parallel with the path of the coal and projecting from the inner face of said plunger. Said rods serve to form con-

tinuous perforations or channels extending longitudinally through the compressed mass of coal as said mass is advanced toward and into the oven, the coal being compressed between or around the said rods in the advance movements of the plunger and the rods extending such distance toward or into the oven that the longitudinal passages or perforations formed by the action of said rods will not be closed by lateral pressure on the mass after the latter passes the free or advance ends of the rods. The passages or perforations so formed in the mass of coal by the rods referred to serve to facilitate the escape of gases and volatile matters from the coal and to thereby aid in the coking operation, while giving more uniform results in the coking of the mass, and especially the central part thereof. At the discharge or delivery end of the coking-chamber means are provided for permitting the discharge of coke without the admission of air, the same preferably consisting of a depending delivery pipe or passage provided with two valves, only one of which is opened at a time during the discharge of the coke.

The operation of the apparatus described in carrying out the process is practically continuous and the coking or distilling operation takes place without the admission of external air to the oven. The entrance of air to the receiving end of the oven is prevented by the solid mass of compressed coal which fills the tapered compressing-passage and the preheating-chamber, and access of air into the delivery end of the oven is prevented by the double valves in the discharge-duct, as hereinbefore described. The compressed and preheated mass of coal is advanced from the preheating-chamber into the oven by an intermittent or step-by-step movement produced by the reciprocation of the feeding and compressing plunger, and such mass is advanced along or through the oven as the coking operation takes place, the gases generated being withdrawn continuously from the coking-chamber.

It is intended that the coking operation shall take place mainly in that section of the coking-chamber which is adjacent to the receiving end of the oven, the section adjacent to the delivery end of said oven being maintained at a lower temperature, so that the mass of coke will be to a greater or less degree cooled before being discharged from the oven.

My invention may be more readily understood by reference to the accompanying drawings, in which—

Figure 1 is a view of an apparatus embodying my invention in longitudinal vertical section taken on a plane passing through the center of the coking-chamber of the oven on the line 1 1 of Fig. 3. Fig. 2 is a like section taken on a plane passing through the heat-

ing-flues of the oven on the line 2 2 of Fig. 3. Fig. 3 is a horizontal section taken on the line 3 3 of Figs. 1 and 2. Fig. 4 is a horizontal section taken upon line 4 4 of Figs. 1 and 2. Fig. 5 is a plan view of the parts located at the receiving ends of two of the ovens shown in Figs. 3 and 4, the parts for feeding, compressing, and preheating the coal employed in connection with one of the ovens being shown in horizontal section, taken on line 5 5 of Fig. 6. Fig. 6 is a view of the parts at the receiving end of one of the ovens, showing said parts partially in side elevation and partially in central vertical section on the line 1 1 of Fig. 3. Fig. 7 is a cross-section taken on line 7 7 of Figs. 1 and 2. Fig. 8 is a cross-section taken on line 8 8 of Figs. 1 and 2. Fig. 9 is an end view of the parts associated with one of the ovens, taken upon line 9 9 of Fig. 6.

The coking-oven illustrated in the accompanying drawings is provided with a series of coking-chambers 1 1 1, which are arranged side by side as common in the construction of Otto Hoffman ovens. Each of the said coking-chambers is equipped with coal feeding, compressing, and preheating devices at the receiving end thereof and with a delivery device at its exit or discharge end, the drawing illustrating in full only one of said coking-chambers and its associated parts. In the walls of the oven which separate from each other the sections of the coking-chambers adjacent to the receiving ends thereof are formed vertical flues or heating-passages 2 2 2, and in the sections adjacent to the discharge ends of the oven are like flues 60 60, serving, however, as cooling-passages. The coking-chambers 1 1 1 are continuous and of uniform internal dimensions from their receiving to their discharge ends, but the oven as a whole consists, in effect, of two sections arranged end to end, one of said sections, which is adjacent to the receiving end of the oven, being provided with heating means and the other section being provided with cooling means.

The means for heating the sections of the coking-chambers adjacent to the receiving ends thereof, which will hereinafter be referred to as the "heating-section," consist of the following parts: Beneath the heating-section of each coking-chamber 1 are located two longitudinally-arranged passages 3 and 4, separated from each other by a vertical transverse partition. Connected with said chambers 3 and 4 are two regenerators 5 and 6 by means of passages 8 and 8, provided with gates or valves 9 and 10. Said regenerators 5 and 6 are located below and extend transversely of the coking-chambers and contain the usual checker-work. Connected with the lower parts of the regenerators are passages or flues 11 11 and 12 12, which are adapted to be connected either with a stack

or chimney or with an air-inlet passage, as common in coking-ovens having two regenerators, as heretofore constructed. Between the longitudinal chambers or passages 3 and 4, associated with two adjacent coking-chambers, are located two longitudinal passages 13 and 14, which communicate with the lower ends of the vertical flues or passages 2 in the walls separating said chambers. Said passages 13 and 14 are separated from each other by a vertical partition-wall 15 and by a horizontal partition 16, extending from the bottom of said wall 15 to the external end wall of the oven, so that the lower part of said chamber 14 extends the full length of the oven-section. The chamber 3 is connected with the chamber 13 by holes or apertures 18 18 formed in the longitudinal wall between said chambers, and the chamber 4 is connected with the chamber 14 by like holes or apertures 19 19. Said chambers 13 and 14 constitute combustion-chambers in which gaseous fuel is burned, air for supporting combustion being supplied from the chambers 3 and 4 through the passages 18 or 19. As shown in the drawings, 20 and 21 indicate gas-supply mains provided with branch pipes 22 and 23, which deliver gas to the outer ends of the chambers or passages 13 and 14 through the end wall of the oven structure.

The operation of the regenerators and associated passages is similar in all respects to the operation of like parts described in my said prior application, and no further description of said parts is necessary here.

The means for cooling the sections of the coking-chambers adjacent to the discharge ends thereof, which will hereinafter be referred to as the "cooling-section," consists of the following parts: Beneath each cooling-section are located two longitudinally-arranged passages 61 and 62, separated from each other by a vertical transverse partition. Connected with the passage 61 by means of the passage 65, provided with a gate-valve 67, is a main air-duct 63. Said air-duct is located below and extends transversely of all the coking-chambers. Said air-duct is connected with an air-inlet and receives air under pressure from a blower. Connected with the chamber 62 by means of the passage 66 is a main air-duct 64. Said air-duct is located below and extends transversely of all the coking-chambers. Said air-duct 64 is connected with a passage 75, which extends longitudinally beneath the ovens and opens into an air-chamber 76, extending transversely of the several preheating-chambers below the latter and forming a temperature-equalizer. From the air-chamber 76 pipes 77, provided with gate-valves 68, lead upwardly to the circulating-chambers surrounding the several preheating-chambers. Said hot-air chamber 76 contains the usual

brick or tile checker-work, such as is used in a regenerator, and its purpose is to keep the air passing therefrom at a uniform temperature, notwithstanding such variations as may from time to time take place in the temperature of the heated air delivered to said chamber. Between the longitudinal chambers or passages 61 and 62, associated with two adjacent coking-chambers in the cooling-section of the oven, are located two longitudinal passages 69 and 70, which communicate with the lower ends of vertical flues or passages 60 60 in the walls separating said chambers. Said passages 69 and 70 are separated from each other by a vertical partition-wall 71. The chamber 61 is connected with the chamber 69 by holes or apertures 73, formed in the longitudinal wall between said chambers, and the chamber 62 is connected with the chamber 70 by like holes or apertures 74. The vertical flues 60 60 are connected at their upper ends with a horizontal passage 72 in the wall separating two adjacent coking-chambers.

In operation cold air from the air-duct 63 enters the chamber 61 through the passage 65 and passes through the aperture 73 into the chamber 69. From the chamber 69 the air rises through the flues 60 60 above the chamber 69, passes horizontally along the passage 72, and descends through the flues 60 60 above the chamber 70 into said chamber 70. The air during its travel through said flues and passages absorbs heat from the walls of the coking-chamber, and thereby acts to cool the said walls and the coke within the coking-chamber. From said chamber 70 the heated air passes through the apertures 74 into the duct 62, thence downward through the passage 66 into the connecting-flue 64 and through the passage 75 into the hot-air chamber 76, located beneath the preheating-chambers.

Now referring to the parts at the receiving end of the oven, these include, in addition to the coal feeding, compressing, and perforating devices, which are like those set forth in my said prior application, a preheating device constructed as follows: 26 indicates a preheating-chamber, such as is described in my said prior application, into which compressed coal is forced by the feeding devices and from which the same is delivered to the receiving end of the coking-chamber. Surrounding the preheating-chamber 26 is a circulating-chamber 36, through which passes the heated air taken from the above-described cooling-passages in the cooling-section of the oven through the passages 75, the hot-air chamber 76, and the passage 77. Said passage 77 enters the circulating-chamber 36 through the bottom wall thereof. The circulating-chamber is provided at its top with exit tubes or pipes 37 37 for the exit of the air from said circulating-chamber.

The heat derived from said heated air passes through the walls of the preheating-chamber and heats the coal therein. The walls of the preheating and circulating chambers preferably consist of two hollow metal shells or sections joined to each other along the longitudinal centers of the said chambers. The said circulating-chamber 36 is shown as water-jacketed, being surrounded by an exterior shell forming a water-chamber 40. Water is supplied to said chamber by means of a water-supply main 41, connected with the chamber by means of branch pipes 42 42, a waste-pipe 43, connected with the water-jacket 40 by branch pipes 44, serving to carry away the water after it has circulated through said water-jacket.

Now referring to the coal-feeding, compressing, and perforating devices at the receiving end of the oven, these parts, as shown in the drawings, are like those illustrated in said prior application and are constructed as follows: 24 indicates a coal-receiving chamber, and 25 a tapered coal-compressing passage located between and connecting the receiving-chamber 24 and the preheating-chamber 26. Said receiving-chamber, the tapered compressing-passage, and the preheating-chamber 26 are connected with each other to form a continuous passage, through which the coal is advanced from the receiving-chamber to the oven. At the top of the receiving-chamber 24 is located an inlet or feed passage 27, provided with a hopper 28 and with a horizontal sliding valve or gate 29. In the said receiving-chamber is located a horizontally-reciprocating plunger 30. Power-actuated means for giving reciprocatory motion to the plunger 30 (shown in the drawings) consist of two horizontal rods 31, which are attached to an upright cross-head 32, secured to the center of a double-ended piston or plunger 33, the opposite ends of which slide in oppositely-arranged hydraulic cylinders 34 and 35, to which fluid under pressure is admitted for advancing and retracting the plunger 30.

The side, top, and bottom walls of the tapered passage 25 join the corresponding walls of the receiving-chamber 24 and the preheating-chamber 26, and the inclination of said walls of the tapered passage is such as to give a desired degree of compression to the mass of coal forced therethrough from the receiving-chamber by the action of the plunger 30. Such mass of coal in the advance movement of the plunger 30 is forced by said plunger from the receiving-chamber through said passage 25 into the preheating-chamber 26.

Extending from the inner face of the plunger 30 are a plurality of rods 50 50, arranged parallel with each other and parallel with the sides of the receiving and preheating chambers. Said rods 50 50 extend from the face of said plunger forwardly through the receiv-

ing-chamber 24, the tapered passage 25, and the preheating-chamber 26. The coal, which is introduced in pulverized form into the receiving-chamber in advance of the plunger, surrounds said rods, and in the advance movement of the plunger the coal is packed solidly around the rods, so that said rods form in the mass of coal a plurality of longitudinal passages, openings, or perforations. The mass of coal is forced through the tapered passage 25, in which it is compressed or solidified, and the effect of the heat to which the said mass is subjected in the preheating-chamber is to produce coherence between the particles of coal in the mass, so that it retains its solid form when it enters the coking-chamber and the longitudinal passages or perforations formed by said rods remain in the mass after the same has been advanced beyond the free ends of said rods.

In carrying out my novel process by the use of the apparatus described the coal will be advanced by the action of the feeding and compressing devices in a solid or continuous mass through the preheating-chamber into the receiving end of the coking-chamber. The coking operation will take place mainly in the part or section of the coking-chamber adjacent to its receiving end, which is heated to the required extent by the heating means associated therewith, as hereinbefore described. As the mass of material which has thus been converted into coke passes through the part or section of the oven adjacent to its discharge end, as described, the mass of coke is deprived of the greater part of its heat through the circulation about the walls of that part of the oven of the air, which acts as a heat absorbing and transmitting medium. The coke is therefore discharged from the oven in a substantially cooled condition. The heat absorbed or abstracted from the coke in the cooling operation by the air or heat transmitting medium, which is circulated in the flues surrounding the cooling section of the oven, is transferred to the preheater and there utilized for preheating the coal preparatory to its entrance into the coking-chamber. In other words, in my process the waste heat from the coking operation is transmitted to the coal and utilized for preheating, so that it is made available in the coking process, with consequent saving in expense for fuel and economy in the operation as a whole.

While I have shown my novel process as carried out by the use of a coke-oven of the Otto Hoffman type, yet the specific form of the heating means for effecting the coking of the coal and the heat-absorbing means for cooling the coke are not essential, and other types of coking ovens, such as the "Rothberg," the "Koppers," and the "Semet-Solvay," may be employed with the same general effect. Moreover, so far as the heat-

ing or coking operation is concerned, an oven for carrying out my process may be of the regenerative type, as in the case of the Otto Hoffman oven, or of the recuperative type, such as the Rothberg and Semet-Solvay ovens.

I claim as my invention—

1. The process of coking coal which consists in applying heat to the coal for the purpose of coking the same, cooling the coke and transmitting to the coal, prior to the coking operation, heat abstracted from the coke in cooling the same.

2. The process of coking coal which consists in advancing the coal in a continuous mass into a coking-oven, applying heat to the part of said oven adjacent to its receiving end to coke the coal and circulating a heat-transmitting medium in contact with the walls of the part of said oven adjacent to its discharge end to abstract heat from the coke.

3. The process of coking coal which consists in advancing coal in a continuous mass into an elongated coking-chamber, applying heat to the coal in the part of said chamber adjacent to its receiving end, abstracting heat from the coke in the part of said coking-chamber adjacent to its discharge end and transmitting to the coal, prior to its entrance into the coking-chamber, heat so abstracted from the coke.

4. The process of coking coal which consists in advancing coal in a continuous mass through a preheating-chamber into an elongated coking-chamber, applying heat to coke the coal in the part of said coking-chamber adjacent to its receiving end, abstracting

heat from the coke in the part of said coking-chamber adjacent to its discharge end, and transmitting heat so derived from the coke to the walls of said preheating-chamber to preheat the coal passing therethrough prior to its introduction into the coking-chamber.

5. The process of coking coal in a coking-oven having a preheating-chamber at the receiving end thereof from which the coal is advanced into the oven, which consists in circulating a heat-transmitting medium in contact with the walls of the oven in the part thereof adjacent to its discharge end, to abstract heat therefrom, and conducting the heat-transmitting medium into contact with the walls of said preheating-chamber.

6. The process of coking coal in a coking-oven provided with a coking-chamber and with a preheating-chamber at the receiving end thereof, which consists in circulating a heating medium in contact with the walls of the coking-chamber in the part thereof adjacent to its receiving end, circulating a heat-transmitting medium in contact with the walls of said coking-chamber in the part thereof adjacent to its delivery end, and conducting said heating medium into contact with the walls of said preheating-chamber.

In testimony that I claim the foregoing as my invention I affix my signature, in the presence of two witnesses, this 24th day of December, A. D. 1906.

SAMUEL B. SHELDON.

Witnesses:

A. V. BYAM,
A. H. VOGEL.