

J. M. MASON.  
 Breech-Loading Fire-Arm.

No. 112,523.

Patented March 7, 1871.

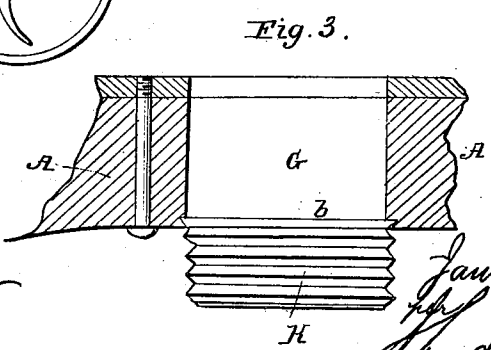
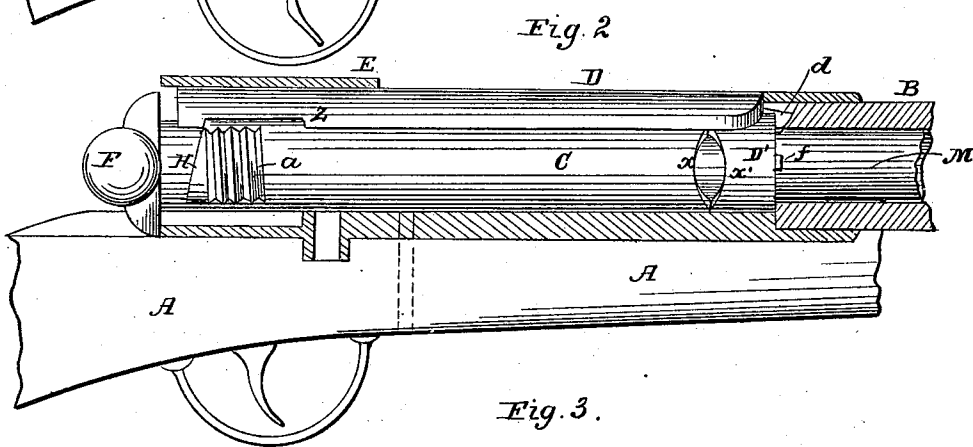
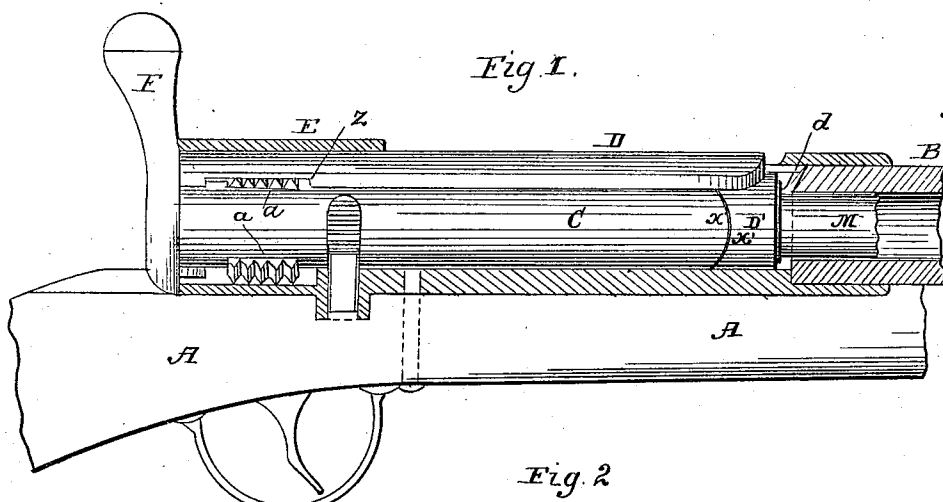

Witnesses:  
*C. L. Overly*  
*A. T. Marr*

Inventor:  
*James M. Mason*  
*Charles V. Mason*  
*attys*

# UNITED STATES PATENT OFFICE.

JAMES M. MASON, OF WASHINGTON, DISTRICT OF COLUMBIA.

## IMPROVEMENT IN BREECH-LOADING FIRE-ARMS.

Specification forming part of Letters Patent No. 112,523, dated March 7, 1871.

*To all whom it may concern:*

Be it known that I, JAMES M. MASON, of Washington, in the District of Columbia, have invented certain new and useful Improvements in Fire-Arms; and do hereby declare that the following is a full, clear, and exact description thereof, reference being had to the accompanying drawing, and to the letters of reference marked thereon, making a part of this specification.

My invention relates to that class of breech-loading fire-arms known as "bolt-guns," and has for its object, first, to cause the cartridge to be forced tightly into the end of the barrel when the cartridge is a little larger than the bore of the gun; second, to cause the cartridge-shell to be partially withdrawn from the barrel after it has been fired and just before the breech-bolt and extractor are withdrawn; third, in the combination, with a breech-loading gun, of a flexible cartridge-shell holder that can be removed from the gun at will, all as more fully hereinafter set forth.

In order to enable others skilled in the art to which my invention appertains to make and use the same, I will now proceed to describe its construction and operation, referring to the annexed drawing, in which—

Figure 1 is a side elevation of the breech-bolt and a longitudinal section of the gun, showing the position of the bolt before the handle is turned over to lock the bolt in the gun, and at the same time cause the cartridge to be pressed into the barrel of the gun. Fig. 2 is a view of the breech-bolt, showing the handle turned to the right into a horizontal position and the cartridge pressed into the gun. Fig. 3 is a view, showing part of a gun-stock with my flexible cartridge-shell holder attached.

In the accompanying drawing, A represents the gun-stock; B, the barrel, and E the receiver, in which the bolt C, which carries the firing-pin, is operated to open and close the breech of the barrel.

F represents the handle, at the rear end, and firmly secured to the bolt. Upon the top of this bolt, and extending from one end to the other thereof, is a metallic strap or bar, D, to the forward end of which, and secured underneath the same, is a small cylinder or recoil-

block, D', which is made the same diameter as the bolt C, and moves with and rests against the forward end of the same. The front end of this recoil-block D' is closed, and provided with a circumferential flange to inclose the flange of the cartridge.

The cartridge-extractor is connected to the inner part of the strap D, and extends forward so that its end *d* passes through the flange in the front of the recoil-block D'.

The firing-pin may be of any suitable construction, and is placed within the breech-bolt C, and extends through an opening in the center of the closed end of recoil-block D', as seen at *f*, Fig. 2.

The rear end of the bolt C is provided with two sectional screws, *a a*, placed opposite to each other a short distance in front of the handle F.

Being aware that the devices above described are not new, I do not wish to be understood as claiming them as any part of my invention.

Difficulties have been experienced in using guns embodying substantially the above devices whenever the cartridges happen to be a little larger than the bore of the gun, or the flange of the cartridge is a little too thick, or when the gun-barrel gets corroded or clogged around the cartridge-entrance, and the cartridge cannot readily be forced fully into its seat; and if forced into its seat the causes above stated prevent the easy and ready extraction of the same.

Difficulties have also arisen in the starting of the cartridge from its seat, even though there be no unusual corrosion or fouling, especially after firing a large charge.

The main part of my invention is intended to obviate these difficulties, and to accomplish the result desired I make the forward end or main portion of the bolt C in the form of a double cam or eccentric, *x*, and make the rear end of the recoil-block of a corresponding form, *x'*, so that by turning the arm F to the right the cam *x*, acting against the cam *x'*, will cause the strap D, recoil-block D', and the extractor to be forced forward a short distance, and the bolt as a whole made longer, as shown in Fig. 2, and press the cartridge close within the gun-barrel.

It will be seen that the rear end of the strap D is provided with a groove, *z*, on its under side, to allow the sectional screw *a* to move with the bolt under the strap; and this groove *z* must be a little longer than the screw, so that the strap may be allowed to slide on the bolt.

Upon the rear part of the upper screw-section, *a*, I make a wedge-shaped cam or incline, H, so that when the arm F is thrown up as seen in Fig. 1, the strap D, together with the recoil-block and extractor, is carried to its normal position. The extractor *d*, being caught over the rim of the cartridge M in the position seen in Fig. 2, is partially withdrawn or started from the barrel of the gun, and can then be easily drawn from the gun upon the withdrawal of the bolt in opening the breech.

In Fig. 3 of the drawing I have represented my improved cartridge-shell receiver or holder, which may be applied to any breech-loading fire-arm known as "bolt-guns."

The stock of the gun is provided with a suitable recess or vertical mortise, G. In the bottom of this recess is applied the receiver or pannier K, which is constructed in the following manner: *b* represents a rectangular metal frame, each end of which is beveled, as shown, to correspond with a bevel made for it to fit in the gun-stock under the recess. Connected to this plate is a sack made of leather or other suitable material, somewhat like a bellows, so that it can be folded up against the gun-stock or allowed to extend below the same, as seen in Fig. 3 of the drawing. This sack, when empty, is supposed to be compressed and lie close up against the lower part of the gun-stock, and may in this position be secured by a button or any suitable catching device; or it may be removed and packed in the bottom of the cartridge-box. The object of this receiver is to catch and save the exploded cartridge-shells, so that they can be refilled and reused. The device being in rear of the barrel of the gun, the extractor or ejector will cause the shells to be brought to the rear and dropped into the sack. Whenever the sack becomes filled the entire device can be easily withdrawn from the gun-stock by sliding the plate *b* side-wise out of the dovetailed groove in the bottom of the stock. The receiver can then be emptied and replaced for use again.

I do not wish to be understood as confining the receiver with my bolt or any particular gun, as it, as well as the bolt, as described, may be used with any breech-loading bolt fire-arm, or one having a rectilinear reciprocating breech-closer.

Having thus fully described my improvements in breech-loading fire-arms, what I claim as new, and desire to secure by Letters Patent, is—

1. A bolt for breech-loading fire-arms provided with a cam upon it, which causes the cartridge to be forced tightly into the gun when the same is rotated, substantially as set forth.

2. In combination with a breech-bolt provided with a single or double cam on its forward end, a short cylinder or recoil-block having a single or double cam, substantially as set forth.

3. In combination with a breech-bolt provided with a single or double cam or similar device, and the recoil-block resting against the front end of said bolt, with a corresponding single or double cam or similar device, an extractor for the cartridge-shell, as set forth.

4. In combination with a breech-bolt and recoil-block, both provided with corresponding cams on their front and rear ends, respectively, an elongated metal strap, D, connected with the recoil-block lying on top of the breech-bolt, and provided with a recess on its under side, which acts over a cam placed at the rear end of the bolt and causes the two to be drawn together, or their adjacent ends kept in contact, substantially as and for the purposes set forth.

5. The combination of the bolt C, provided with cam H, with the recoil-block D', connected with the strap D, having a recess, *z*, substantially as and for the purposes set forth.

6. The combination of the strap D, extractor *d*, recoil-block D', cam *x'*, bolt C, provided with arm F, and cams H and *x*, all constructed and operated substantially as and for the purposes set forth.

7. In combination with a breech-loading gun provided with a mortise through the stock in the rear of the gun-barrel, a cartridge-shell receiver, substantially as set forth.

8. The combination of the beveled metal frame *b* and the extensible sack K with the gun-stock A, all substantially as and for the purposes set forth.

In testimony that I claim the foregoing I have hereunto set my hand this 25th day of February, 1871.

J. M. MASON.

Witnesses:

C. L. EVERT,  
A. N. MARR.