

(12) PATENT
(19) AUSTRALIAN PATENT OFFICE

(11) Application No. AU 199734179 B2
(10) Patent No. 717552

(54) Title
Method and apparatus for osteochondral autograft transplantation

(51)⁶ International Patent Classification(s)
A61B 017/16 A61B 017/56

(21) Application No: 199734179 (22) Application Date: 1997.08.14

(30) Priority Data

(31) Number	(32) Date	(33) Country
60/024045	1996.08.16	US
08/885752	1997.06.03	US

(43) Publication Date : 1998.03.12
(43) Publication Journal Date : 1998.03.12
(44) Accepted Journal Date : 2000.03.30

(71) Applicant(s)
Arthrex, Inc.

(72) Inventor(s)
Vladimir Bobic; Craig D Morgan; Reinhold Schmieding; Stephen S Burkhardt

(74) Agent/Attorney
GRIFFITH HACK, GPO Box 3125, BRISBANE QLD 4001

(56) Related Art
US 5603716
US 5496326
US 5423823

METHOD AND APPARATUS FOR
OSTEOCHONDRAL AUTOGRAFT TRANSPLANTATION

ABSTRACT OF THE DISCLOSURE

A method and apparatus for autogenous transplantation of articular cartilage with bone from one site, such as in the knee, to another to treat chondral defects. Graft harvesters and recipient site harvesters create identically-sized donor graft osteochondral cores and recipient sockets. Collared pins disposed within the harvesters facilitate removal of the harvested cores. Windows formed in the side of the harvester tubes allow visualization of the graft, such as when being inserted into the recipient socket. A removable three-piece driver/extractor is provided to allow for impact-driving and depth control of the harvesters at the selected sites.



METHOD AND APPARATUS FOR
OSTEOCHONDRAL AUTOGRAFT TRANSPLANTATION

BACKGROUND OF THE INVENTION

1. Field of the Invention:

15 The present invention relates to the surgical treatment of chondral defects and, more specifically, to a method and apparatus for autogenous transplantation of articular cartilage/bone cores in knees having chronic anterior cruciate ligament (ACL) deficiency, or isolated articular defects.

2. Description of the Related Art:

20 Chronic ACL deficiency can result in a wide range of chondral damage, varying from superficial blemishes and fissures, to large, full-thickness defects. These lesions may also occur as isolated pathology in cruciate normal knees.

25 Chondral defects of the femoral condyles are widely recognized indications which comprise approximately 5% of all knees undergoing arthroscopy. Treatment, however, is difficult and controversial. In

SP5C\DC19570



earlier known methods, meniscal pathology was treated, and the ACL was reconstructed, but the chondral lesion usually was left untreated. This approach leads to lesion enlargement and ultimately an advancing arthritic condition.

5 A protocol of arthroscopic osteochondral autograft transplantation for repairing chondral defects has been developed and tested in knees having chronic ACL deficiency by Vladimir Bobić, as reported in Arthroscopic Osteochondral Autograft Transplantation In ACL Reconstruction: A preliminary clinical study; Knee Surgery, Sports Traumatology Arthroscopy (1996), incorporated herein by reference.

10 The transplantation procedure, which is intended to prevent further joint degeneration and possible development of osteoarthritis, involves selecting donor sites for osteochondral cores, capped with intact cartilage, prior to notchplasty. Donor sites are selected along the anterolateral and superior aspect of the notchplasty area, or on the superolateral and anterolateral aspect of the lateral femoral condyle in the non-weightbearing area above the sulcus terminalis. At the donor sites, multiple osteochondral cores 5 mm to 9 mm in diameter and 10 to 15 mm long, are harvested using tubular cutting instruments.

15 20 25 30 Recipient repair sites typically are located on the weightbearing area of the medial and lateral femoral condyles. Full-thickness chondral defects, typically larger than 10 mm in diameter, and up to 20 mm, are selected for treatment. Recipient sockets at the repair

sites are prepared, and the donor cores are transferred and press-fitted into the recipient sockets.

5 The transplantation procedure described above has various difficulties associated with it. For example, removing the osteochondral cores from the tubular cutting instruments is difficult. In addition, improvements are needed in the formation of the donor cores and recipient sockets, especially to facilitate depth control during harvest as well as transplant
10 insertion. In general, improvements are required in the instrumentation and techniques available to perform the transfer procedure.

SUMMARY OF THE INVENTION

15 The present invention overcomes the deficiencies in the prior art by providing surgical instruments and protocols for performing osteochondral transplant procedures using a series of thin-walled (0.5 mm) cutting tubes. Osteochondral cores, made up of hyaline cartilage capping subchondral bone, are
20 harvested, preferably autogenously. The osteochondral cores, preferably 10 to 15 mm in length, are transplanted into sockets created in the defect to accept the transplanted core, or multiple cores, in a press-fit manner. The technique of the present invention may be
25 carried out as either an open procedure or arthroscopically. Determinations regarding the protocol used will be based, for example, on the location, geometry, and extent of the chondral defect and the harvest sites.

The instrumentation of the present invention includes a series of core harvesters. The harvester of the present invention preferably includes a hollow tube having a distal cutting edge and a cannulated handle attached proximally. Within each core harvester, a collared pin is disposed slidably to facilitate removal of the harvested osteochondral core. The collared pin acts as a plunger to urge the harvested core from the lumen of the core harvester tube, and preferably has a concave face for enhanced biomechanical contact with the curved surface of the harvested core.

Preferably, two types of harvesters are provided: a donor harvester for obtaining donor osteochondral cores, and a recipient site harvester for forming recipient sockets at repair sites. Advantageously, the inner diameter of the donor harvester is equal to the outer diameter of the recipient site harvester. The outer diameters differ by 1 mm to accommodate the 0.5 mm wall thickness. The thin walls minimize bone and tissue damage.

The harvesters are provided in a range of sizes. To assist in harvesting to the proper depth, markings are provided on the instruments. The markings preferably are located on the outer surface of the harvester tubes for direct visual alignment with the surface of the tissue being harvested. Slotted windows are provided through the side walls of the tube to allow visualization of the harvested osteochondral core within the lumen of the harvester tube, allowing for visual confirmation of core length and surface geometry, for

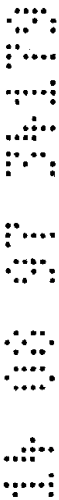

example, and for visual confirmation of depth during insertion.

5 The two types of bone harvesters can be distinguished by the formation of the sharp, distal cutting edge. On the donor graft harvesters, the distal cutting edge preferably is formed as an inward bevel, such that the cutting edge is formed by a slanted surface that slopes distally and inward, toward the central axis, from the outer surface to the inner surface of the
10 harvester tube wall. Accordingly, the acutely-angled cutting edge is formed at the junction between the outer, beveled surface and the inner surface of the harvester tube wall.

15 On the recipient site harvesters, the distal cutting edge preferably is formed with a bevel opposite to that of the donor graft harvester. That is, the cutting edge is formed by a slanted surface that slopes distally and outward from the central axis, from the inner surface to the outer surface of the harvester tube
20 wall. Accordingly, the acutely-angled cutting edge is formed between the inner, beveled surface and the outer surface of the harvester tube wall.

25 The two harvesters cooperate for precise correspondence in size between the donor graft and the recipient site. Correct sizing avoids problems associated with an improper fit of the graft in the recipient site, including compression or insufficiency of the repair.

30 According to a preferred method, the donor harvester is inserted into a tube harvester driver/extractor and placed over the selected hyaline

cartilage harvest site. The donor harvester is placed flush with the articular cartilage surface and impacted, using a mallet for example, to a selected depth of approximately 10 to 15 mm. After complete insertion to the selected depth, the driver/extractor is twisted and gently rocked to fracture the cancellous base for removal of the osteochondral core.

A recipient site is prepared with a recipient site harvester using a similar method. Alternatively, recipient sockets can be formed using various techniques, such as by drilling. The donor core preferably is pressed into the recipient site directly from the donor harvester.

Prior to insertion, size correlation between the donor core and the recipient site is provided by using a graft sizer and an alignment stick. The depth of the recipient site is determined using the alignment stick. If the graft osteochondral core is too long, adjustment of the core length or the length of the recipient site can be effected accordingly.

Using the driver/extractor, the donor osteochondral core is advanced with the collared pin so that the distal end of the core is flush with the end of the cutting edge of the harvester tube. As a manual aid to insertion depth control, the collared pin is sized so that the proximal end comes flush with the proximal end of the harvester handle, when the distal end of the collared pin is 1 mm recessed from the cutting edge of the cutting end of the bone harvester. Accordingly, nearly-flush, anatomical insertion of the cartilage/bone

core can be obtained without direct visual observation, and over-insertion is avoided.

5 After insertion, the osteochondral core insert is brought flush anatomically using a sizer/tamp. The graft is pressed with the sizer/tamp such that the surface of the graft comes into flush alignment with the normal articular cartilage surrounding the recipient repair site.

10 Although the instruments and techniques are described herein in connection with a specific autograft application in the ACL-deficient knee, they can be applied to ACL-normal knees, for treatment of joints other than the knee, and for xenogenous procedures. In addition, indications for the instrumentation and techniques of the invention can be extended to include
15 other treatments, such as, for example, osteochondritis dissecans, allograft transplantation, bone grafting, graft fixation, and focused bone core biopsy.

20 Other features and advantages of the present invention will become apparent when the following description is read in conjunction with the accompanying drawings.

BRIEF DESCRIPTION OF THE DRAWINGS

25 Fig. 1 is a partial side view of a donor graft harvester according to the present invention.

Fig. 2 is a cut-away side view of the donor graft harvester of Fig. 1.

Fig. 3 is a partial side view of a recipient site harvester according to the present invention.

Fig. 4 is a cut-away side view of the recipient site harvester of Fig. 3.

Fig. 5 is a side view of a collared pin according to the present invention.

5 Fig. 6 is a cut-away side view of a driver/extractor handle according to the present invention.

Fig. 7 is a side view of a graft sizer/tamp according to the present invention.

10 Fig. 8 illustrates chondral defect size determination and surgical planning according to the present invention.

Fig. 9 illustrates donor harvester tube impaction according to the present invention.

15 Fig. 10 illustrates proper alignment of the donor harvester tube according to the present invention.

Fig. 11 illustrates donor core harvesting according to the present invention.

20 Figs. 12 illustrates bone core sizing according to the present invention.

Fig. 13 illustrates recipient socket harvester impaction according to the present invention.

Fig. 14 illustrates recipient socket depth control according to the present invention.

25 Fig. 15 illustrates recipient socket core extraction according to the present invention.

Fig. 16 illustrates recipient socket sizing and preparation according to the present invention.

30 Fig. 17 illustrates assembly preparation of the driver/extractor of the present invention.

Fig. 18 illustrates preparation of the driver/extractor and donor core harvester for insertion in the recipient site according to the present invention.

5 Fig. 19 illustrates donor core insertion according to the present invention.

Fig. 20 illustrates insertion of the donor core according to the present invention.

Fig. 21 illustrates final donor core seating according to the present invention.

10 Fig. 22 is a detailed closeup of the donor core seating step of Fig. 21.

Fig. 23 illustrates a completed transplantation according to the present invention.

15 Fig. 24 illustrates multiple transfers according to the present invention.

Fig. 25 illustrates multiple transfers according to the present invention.

DETAILED DESCRIPTION OF THE PREFERRED EMBODIMENTS

20 Referring to Figs. 1 and 2, a donor graft harvester 2 is shown. The donor graft harvester includes a hollow tube 4 attached to a cannulated handle 6.

25 The graft harvester tube has a sharp cutting edge 8 formed on the distal end thereof. The sharp edge is formed by a beveled surface 10 sloping inward distally from the outer surface to the inner surface of tube 4.

The donor harvester preferably is provided in a range of sizes. Accordingly, the inner diameters of hollow tubes 4 are, for example, 5, 6, 7, 8, and 9 millimeters. The walls of the harvester tubes are

typically 0.5 millimeter thick. The thin walls minimize bone and tissue damage.

As shown in Fig. 1, windows 11 and depth markings 12 are provided on the tube of the donor site harvester to assist the surgeon during insertion of the
5 harvester into the bone at the donor site. A longitudinal marking line (not shown) provided at the tip of each harvester facilitates core alignment in the recipient socket.

10 Windows 11 allow for arthroscopic confirmation of donor bone plug extraction prior to complete removal of the donor harvester, as discussed below. In addition, windows 11 allow a comparison of overall core length between donor and recipient cores. Windows 11 also allow
15 visual control of core insertion depth by calibrating the collar and tube laser marks. Also, windows 11 provide increased surface friction between the tube and the osteochondral core to ensure core extraction, especially at lengths over 10 mm.

20 Referring to Figs. 3 and 4, a recipient site harvester 14 according to the present invention is shown. The recipient site harvester includes a hollow tube 16 attached to a cannulated handle 18. The harvester has a sharp cutting edge 20 formed on the distal end of tube
25 16. The sharp edge is formed by a beveled surface 22 sloping outward distally from the inner surface to the outer surface of tube 16. See Fig. 4.

The recipient site harvester also is provided in a range of sizes. Accordingly, the outer diameters of
30 hollow tubes 16 are, for example, 5, 6, 7, 8, and 9 millimeters, in correspondence with the inner diameter of

the associated donor graft harvester described above. As with the donor harvester, the walls of the recipient harvester tubes are thin, and windows 23 and depth markings 24 are provided on the tube, in a manner and for reasons similar to those described above with respect to donor harvester 2.

Referring to Fig. 5, a collared pin 26 according to the present invention is shown. Pin 26 is made up of a collar 28 disposed on a distal end of a handle 30. The surface 32 at the distal end of collar 28 is smooth and concave for enhanced biomechanics and to prevent damage to the cartilaginous surface of the graft core, similar to that of the sizer/tamp, described below. The preferred spherical radii of the concavity for the distal end surfaces for various instrument sizes are set forth in the following Table I:

Table I

	Size	Diameter	Radius [metric]
20	5 mm	.151 [3.84]	.109 [2.74]
	6	.191 [4.85]	.229 [5.82]
	7	.230 [5.84]	.385 [9.78]
	8	.269 [6.83]	.580 [14.73]
	9	.309 [7.85]	.831 [21.11]
	10	.348 [8.84]	1.090 [27.69]
25	11	.387 [9.83]	1.410 [35.81]
	12	.427 [10.85]	1.754 [44.55]
	13	.466 [11.84]	2.144 [54.46]
	14	.506 [12.85]	2.578 [65.48]
	15	.545 [13.85]	3.046 [77.37]

Pin 26, having a collar 28 of appropriate size approximating the inner diameter of the harvester, is received within handle 6 of the donor graft harvester, or handle 18 of the recipient site harvester, prior to

insertion of the respective harvester into the selected
harvesting or donation site. Accordingly, the proximal
end of pin 28 is inserted through hollow tube 4, 16,
respectively, such that the collar is disposed within the
5 tube prior to harvesting cores at the donor graft or
recipient sites.

The proximal end of the pin extends beyond the
proximal end of the harvester to an extent at least equal
to the length of the tube, such that the harvested core
10 can be removed easily from the lumen of the harvester
tube by urging the handle of the collared pin distally to
advance the harvested core. In this respect, the
harvesters of the present invention are similar to the
coring reamer of co-owned U.S. Patent No. 5,423,823, the
15 disclosure of which is incorporated herein by reference,
and the bone harvester disclosed in co-owned U.S. Patent
No. 5,603,716.

Referring to Fig. 6, a tube harvester
driver/extractor 34 according to the present invention is
20 shown. Cannulated tube harvester driver/extractor 34
preferably is assembled of three sections including a
chuck end 36, a handle 37 and an impact end 38. Chuck 35
at the distal end of driver/extractor 34 secures onto the
proximal end of harvesters 2, 14, and is cannulated to
25 receive the proximal end of pin 26. Removable handle 37
is used to manipulate the driver/extractor assembly.

According to the inventive procedure, as
described more fully below, impact end 38 is struck with
a mallet to drive the harvester/driver assembly into the
30 selected harvesting site. Upon removal of end 38 and
handle 37, the proximal end of pin 28 of collared pin 26

is exposed for removal of the harvested cores from the harvester tubes, also set forth more fully below. Alternatively, the entire driver/extractor can be removed from the harvester prior to transfer.

5 Referring to Fig. 7, a graft sizer/tamp 40 is shown. Sizer/tamp 40 has a tamp head 42 disposed on a shaft 44. Three flats 46 are formed on the proximal end so that sizer/tamp 40 can be chucked into driver/extractor 34. The core-contacting surface at the distal
10 end of the sizer/tamp is smooth and has a spherical concavity, similar to that of the collared pin discussed above. The spherical concavity of the sizer/tamp differs from that of the collared pin in that the outer edge of the concavity extends to and coincides with the outer
15 diameter of the sizer/tamp. In contrast, the outer diameter of the collared pin is radiused, and the outer edge of its spherical concavity is set in slightly from the radiused edge. Table II sets out the preferred spherical radii of the concave surface for various sizes
20 of the sizer/tamps, as follows:

Table II

Size	Diameter	Radius [metric]
5mm	.197 [5.0]	.29 [7.4]
6	.236 [6.0]	.46 [11.7]
7	.276 [7.0]	.68 [17.3]
8	.315 [8.0]	.94 [23.9]
9	.354 [9.0]	1.22 [31.0]
10	.394 [10.0]	1.55 [39.4]

25
30 The method according to a preferred embodiment of the present invention will be described with reference to Figs. 8 through 18.

Referring to Fig. 8, an anterior aspect of a right knee 50 is shown diagrammatically. A chondral defect 52 in femoral condyle 54 is inspected arthroscopically and the extent of the lesion assessed with sizer/tamp 40. Tamp 40 has the appropriate 5, 6, 7, 8, or 9 mm diameter Delrin head, which correlates with the diameter of the cutting tube harvesters.

A tamp 40 of appropriate size also can be used to evaluate potential harvest donor sites, such as site 55, in an area 56 along the outer edges of the non-articulating margin of the lateral femoral condyle above the sulcus terminalis or directly adjacent to the superolateral margin 57 of the intraarticular notch.

Surgical planning with respect to transferring single or multiple osteochondral cores, appropriate osteochondral core diameter, and whether to proceed with an arthroscopic versus an open procedure must be assessed prior to further surgical transplantation intervention. Selection and size of single or multiple core grafts should be based on harvest site accessibility and the convex/concave surface shape relationship of the available donor and recipient sites.

The appropriate, single-use tube harvester set of one-each donor harvester 2 and one-each recipient harvester 14 with respective collared pins 26 is selected based on defect and harvest site measurements. The donor tube harvester is selected to have an outer diameter 1 mm larger than the recipient tube harvester. The inner diameter of the donor tube is thus equal to the recipient outer tube diameter to assure a press fit fixation of the donor core in the recipient site. Tube harvester sets

consist of 5 and 6 mm, 6 and 7 mm, 7 and 8 mm, 8 and 9 mm, or 9 and 10 mm sizes.

Referring to Fig. 9, the donor tube harvester 2 of the appropriate diameter and labeled "DONOR" is inserted fully into the tube harvester driver/extractor 34 (see Fig. 6) and placed over the hyaline cartilage harvest site 55. Care must be taken to adjust the insertion and/or knee flexion angle so that the tube harvester end is flush with the articular cartilage prior to impaction. See Fig. 10. The tube harvester is driven into subchondral bone with a mallet 58 to a depth of approximately 15 mm. Care should be taken not to rotate the harvester during insertion so as to avoid damaging the core to be harvested.

During an arthroscopic procedure, a slotted cannula (not shown) may be used to facilitate larger diameter tube harvester insertion into the joint. After insertion, the slotted cannula is pulled back along the tube harvester shaft and removed sideways through the slot to increase intraarticular visualization, tube harvester mobility, and fluid distension.

Referring to Fig. 11, driver/extractor 34 is rotated, preferably about 90° clockwise, about 90° counter-clockwise, and then gently rocked, superior and inferior, to fracture the cancellous base for removal of the osteochondral core. Donor tube harvester 2 is then retrograded from the donor site with the harvested core captured within the tube.

The harvested core can be visualized through windows 11 to verify that the core has been captured successfully within the harvester. If rotation and



extraction of the tube harvester should fail to capture the core for removal, reinsertion and further impaction of the tube harvester up to 20 mm with subsequent rotation and extraction steps may be indicated.

5 Once the donor core is removed, its length and hyaline cartilage thickness can be seen through the windows 11 in the harvester, as shown in Fig. 12. Accurate measurements can be obtained using a calibrated alignment stick 59, discussed further below. After
10 extraction, the donor tube harvester 2 and the captured core are removed from the driver/extractor and placed in a secure, sterile holding area.

Referring to Fig. 13, the appropriately-sized tube harvester 14 labeled "RECIPIENT" and collared pin 26
15 from the tube harvester set are inserted fully into the tube harvester driver/extractor 34. If a single core transfer is indicated to replace the surface of the defect 52, recipient tube harvester 14 is placed over the defect and driven into the subchondral bone with mallet
20 58. Again, rotation of the recipient harvester is avoided during insertion of the harvester, as noted above with respect to insertion of the donor harvester. The preferred depth of about 13 mm. is determined with the tube harvester millimeter depth markings 24 on the outer
25 surface of tube 16, as shown in Fig. 14.

Care should be taken to select the proper
insertion angle and knee flexion to allow the tube
harvester to sit flush to the chondral surface prior to
impaction. If multiple core transplantation is desired,
30 the tube harvester is placed over the appropriate quadrant in the defect.



Also, during socket creation, attention to maintaining the harvester at a 90° angle to the articular surface, in both the sagittal and coronal planes, is very important to obtain a flush transfer. See Fig. 14.

5 If angled harvesting must be performed due to anatomical obstruction to 90° placement of tube harvester flush with hyaline cartilage, a longitudinal marking line (not shown) at the tip of each tube harvester should be rotated to align with the leading cutting edge into
10 cartilage during donor core harvesting. Recipient harvesting should be performed at an angle as close as possible to the angle used during donor core harvesting. This facilitates close approximation of the angled
15 hyaline cartilage donor surface with the surrounding cartilage of the angled recipient socket by aligning the longitudinal marking line and leading cutting edge of the donor tube against the recipient socket rim during donor core insertion.

Referring to Fig. 15, after sufficient tube harvester depth is determined, the tube harvester driver/extractor 34 is rotated and gently rocked, as with the donor harvester above, to fracture the cancellous bone at the distal end of the tube. Extraction of the tube harvester and core can be facilitated by simultaneous counter rotation and extraction of the tube driver so as to form recipient socket 60.

After extraction of the harvester and its captured osteochondral core, the lengths of the donor and recipient cores can be compared directly by placing the donor and recipient harvesters side by side. The harvested cores can be visualized through windows 11 and

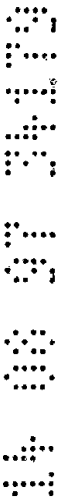

23 in the donor and recipient harvesters, respectively. Adjustments to the length of the harvester autograft donor core can be made accordingly. Preferably, the distal end of the donor core is smoothed prior to insertion into the recipient site.

Referring to Fig. 16, calibrated alignment stick 59 of an appropriate diameter can be used to measure the depth of recipient socket 60. The alignment stick also can align correctly the angle of the recipient socket with respect to the position of an insertion portal when an arthroscopic approach is used. Advantageously, the alignment stick also can be used to fine tune the recipient socket length as desired to match the length of the donor core. Accordingly, alignment stick 59 is impacted with mallet 58 until the desired depth is achieved.

For insertion of the autograft core, the recipient tube harvester 14 is replaced with the 1 mm diameter-larger donor tube harvester 2 and collared pin with the captured autograft core. The donor tube harvester is inserted fully into the tube harvester driver/extractor 34.

Referring to Figs. 17 and 18, after donor tube harvester 2 reinsertion into the driver/extractor 34, the driver/extractor impaction cap 38 is unscrewed and the T-handled midsection 37 is removed. Accordingly, the proximal end of collared pin 26 is exposed, which is used to advance the core into the recipient socket 60.

A stainless steel pin calibrator 62 is applied onto the open handle end for protection during further impaction, to maintain alignment of the collared pin, and

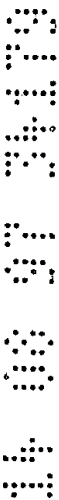

to provide mechanical control of the bone core insertion. The pin calibrator preferably has an O-ring that press fits into the handle, and a small hole in the center that is threaded, so that the calibrator can be pulled out of the handle with a threaded retriever.

As shown in Fig. 19, the distal end of donor harvester 2 is inserted into recipient site 60. The beveled surface 10 helps to guide the harvester at the recipient site and assists in providing a secure fit and alignment of the donor harvester. A mallet is used to tap lightly onto the proximal end of handle 28 of collared pin 26 to drive the core into the recipient socket 60 while maintaining stable positioning of the harvester tube and knee flexion angle.

The core is advanced so that 1 mm of core remains proud, as shown in Figs. 19 and 20. Accordingly, the collared pin 26 is advanced until the end of the pin is flush with the pin calibrator 62. The pre-determined length of the collared pin is designed to advance the bone core so that 1 mm of the graft will be exposed outside the recipient socket when the pin is driven flush with the end of the proximal face of the pin calibrator. Control of the core insertion also can be obtained by visualizing the core and collared pin advancement through windows 11 in the side of the harvester.

Advantageously, incomplete insertion of the core avoids driving the core too far, which could result in a counter-sunk cartilage surface, requiring further invasive steps to pull back the core so as to be flush to surrounding articular cartilage. Over-insertion also is

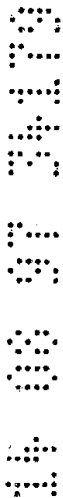

prevented by proper recipient socket preparation using the alignment stick, as set forth above.

Referring next to Fig. 21, sizer/tamp 40 is chucked into driver/harvester 34 for seating the core flush with the surrounding hyaline cartilage. According to one embodiment of the method of the present invention, the sizer/tamp diameter is at least 1 mm larger than the diameter of the core. As shown in Fig. 22, the larger diameter tamp provides complete control of proper core insertion depth flush to surrounding articular cartilage and eliminates any potential of overdriving.

According to another embodiment of the inventive method, sizer/tamp 40 is the same as that used to determine the core size required, and is the same size as the osteochondral core. The tamp is used in an off-center position with respect to the core, so that the overhanging edge of the sizer/tamp encounters the surrounding cartilage area and prevents overinsertion of the bone core. The face of the core is seated flush with the surrounding cartilage surface, which is achieved by light tapping with the mallet 58. The completed transfer is shown in Fig. 23.

When multiple cores of various diameters are to be harvested and transferred into specific quadrants of the defect, each core transfer should be completed prior to proceeding with further recipient socket creation. See Figs. 24 and 25. This prevents potential recipient tunnel wall fracture and allows subsequent cores to be placed directly adjacent to previously inserted cores when desired.



Donor sockets 64 are routinely left open after harvesting and fill in with cancellous bone and fibrocartilage within 8 to 12 weeks. Alternatively, cancellous bone harvested from the defect may be inserted into donor sites, and should be tamped firmly into the donor socket with a sizer/tamper or alignment stick to compress the cancellous bone for enhanced fixation.

Although the present invention has been described in relation to particular embodiments thereof, many other variations and modifications and other uses will become apparent to those skilled in the art. Therefore, the present invention is to be limited not by the specific disclosure herein, but only by the appended claims.



THE CLAIMS DEFINING THE INVENTION ARE AS FOLLOWS:

1. A method of transplanting osteochondral cores in a joint having articular cartilage and subchondral bone, using a cutting tube having a distal end and a pin, the method comprising the steps of:

- 5
- a. inserting the pin into the cutting tube to form a cutting tube and pin assembly;
 - b. introducing the cutting tube into the joint;
 - 10 c. placing the distal end of the cutting tube and pin assembly prior to introducing the pin into the joint over a selected site in the joint; and
 - d. driving the distal end of the cutting tube into the subchondral bone to a predetermined depth to form an osteochondral core.

15

2. The method of claim 1, further comprising the step of removing the cutting tube from the joint with the osteochondral core.

20

3. The method of claim 2, wherein the osteochondral core has a cancellous base, the method further comprising the step of rotating the cutting tube having been driven to the specified depth to fracture the cancellous base.

25

4. The method of claim 2, further comprising the steps of:

- forming a socket in the joint, the socket having an opening;
- 30 introducing the cutting tube with the osteochondral core into the joint;
- positioning the distal end of the cutting tube at the opening of the socket; and
- urging the pin distally so as to advance the
- 35 osteochondral core into the socket.



5. The method of claim 4, wherein the step of forming socket in the joint is performed by removing a bone core.

6. The method of claim 4, further comprising the step of
5 seating the osteochondral core so that a proximal surface of the osteochondral core is flush with the opening of the socket.

7. The method of claim 4, wherein the step of forming the
10 socket comprises performing steps a through d of claim 1 using a cutting tube having an outer diameter equal to an outer diameter of the osteochondral core.

8. The method of claim 4, further comprising the step of
15 measuring the socket with an alignment stick.

9. The method of claim 4, further comprising the step of shaping the socket with an alignment stick.

10. The method of claim 1, wherein the cutting tube is
20 driven without rotation.

11. The method of claim 1, wherein the step of driving the
25 cutting tube comprises impacting the cutting tube.

12. The method of claim 1, wherein the pin has a collar.

13. A method of transplanting osteochondral cores in a
30 joint having articular cartilage and subchondral bone, using a cutting tube having a distal end and slotted windows, and a pin slidably disposed within the tube, the method comprising the steps of:

- a. introducing the cutting tube into the joint;
- b. placing the distal end of the cutting tube over a
35 selected site in the joint;
- c. driving the cutting tube into the subchondral bone to form an osteochondral core;



d. removing the cutting tube with the osteochondral core from the selected site;

e. visualizing the osteochondral core within the cutting tube; and

5 f. advancing the pin with respect to the cutting tube so as to urge the osteochondral core from the cutting tube.

10 14. The method of claim 13, wherein the cutting tube has an inner diameter, and the method further comprises the step of:

forming a socket at a recipient site using a recipient tube having an outer diameter equal to the inner diameter of the cutting tube; and

15 wherein, in the step of advancing the pin with respect to the cutting tube, the osteochondral core is urged from the cutting tube into the socket formed at the recipient site.

20 15. A method of transplanting osteochondral cores in a joint having articular cartilage and subchondral bone, using a tube having means for visualizing an osteochondral core contained within the tube, the method comprising the steps of:

25 a. introducing an osteochondral core into the tube;

b. introducing the tube to a socket formed at a recipient site within the joint;

c. urging the osteochondral core from the tube into the socket;

30 d. visualizing the osteochondral core within the tube by way of the visualization means; and

e. orienting the osteochondral core with respect to the socket at the recipient site.

35 16. The method of claim 15, wherein the step of introducing the osteochondral core into the tube comprises the step of:



cutting the osteochondral core from a donor site using the tube, the tube comprising a donor tube having an inner diameter; and

5 wherein the socket formed at the recipient site within the joint is formed using a recipient tube having an outer diameter equal to the inner diameter of the donor tube.

17. A method of transplanting osteochondral cores in a joint having articular cartilage and subchondral bone, using a tube having a distal end and a pin, the method comprising the steps of:

inserting the pin into the tube;
placing the distal end of the tube over a selected site in the joint;

15 introducing an osteochondral bone core into the tube;
removing the tube from the selected site with the bone core remaining within the tube;

positioning the distal end of the tube at an opening of a bone socket; and

20 urging the pin distally so as to advance the bone core into the bone socket.

18. The method of claim 17, wherein the pin has a collar.

19. The method of claim 17, wherein the bone socket is formed by cutting with a tube having an outer diameter equal to an outer diameter of the osteochondral core.

20. The method of claim 17, wherein the step of inserting the pin into the tube is performed prior to the step of introducing the osteochondral bone core into the tube.

Dated this 2nd day of September 1999

35 ARTHREX, INC.
By Its Patent Attorneys
GRIFFITH HACK



14 08 97 34178

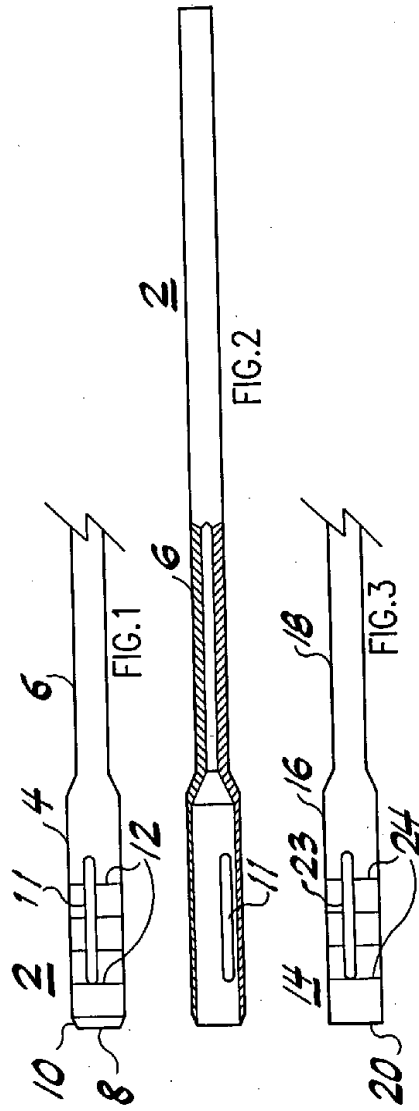

14 08 37 34179

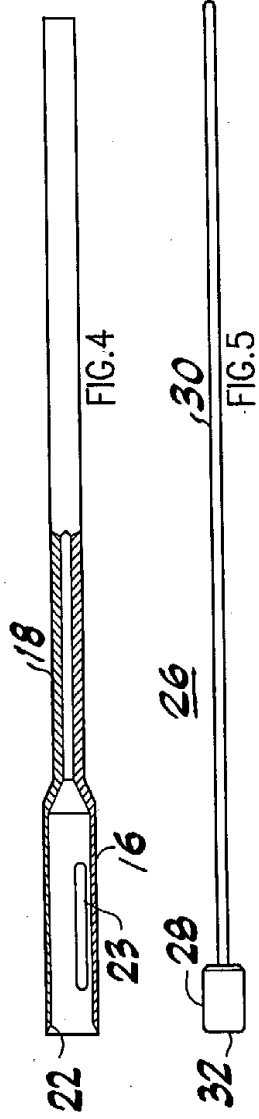

34179/97

3/19

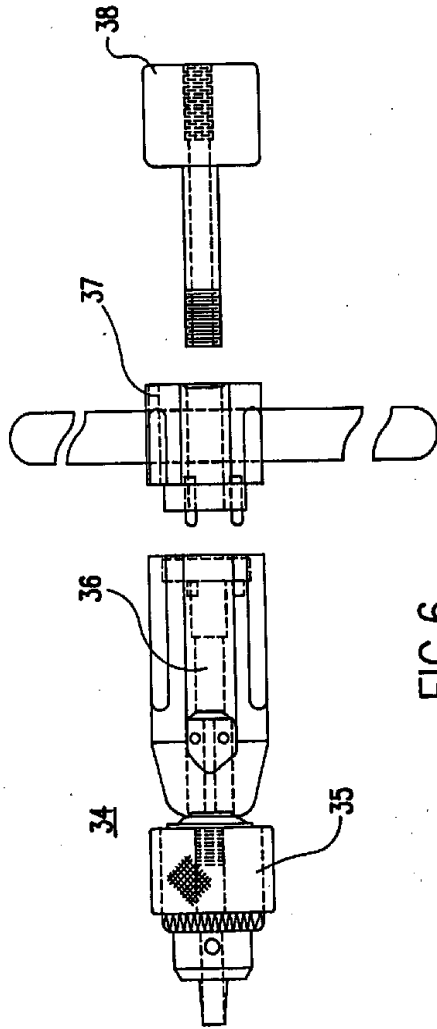

FIG. 6

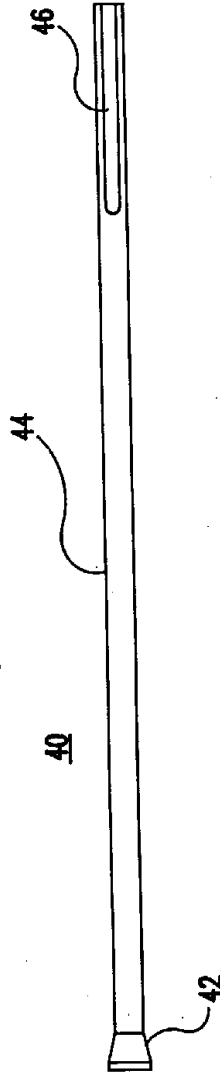

FIG. 7

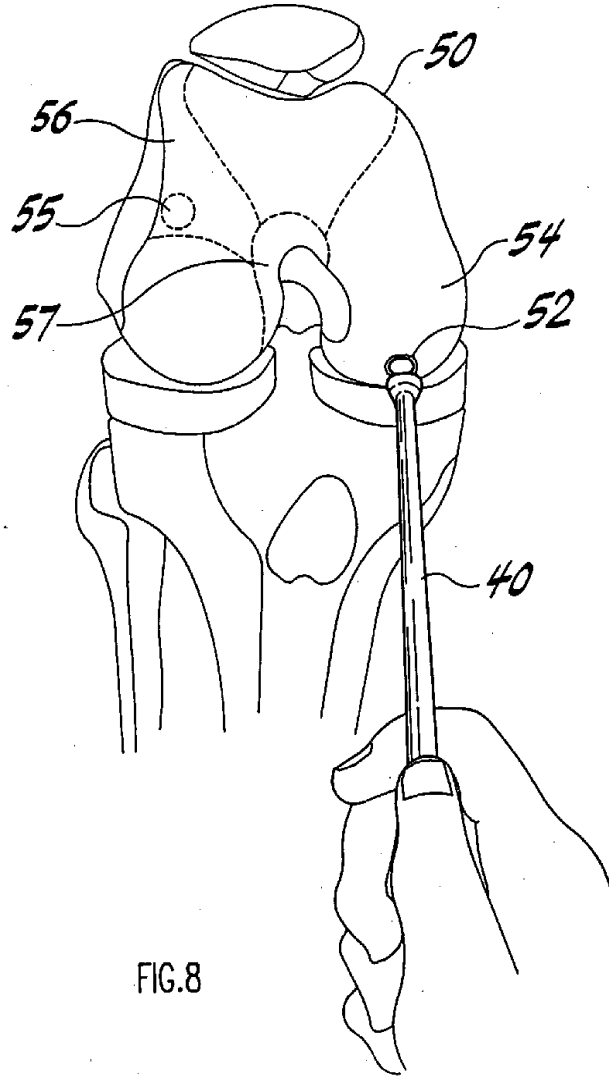

FIG.8



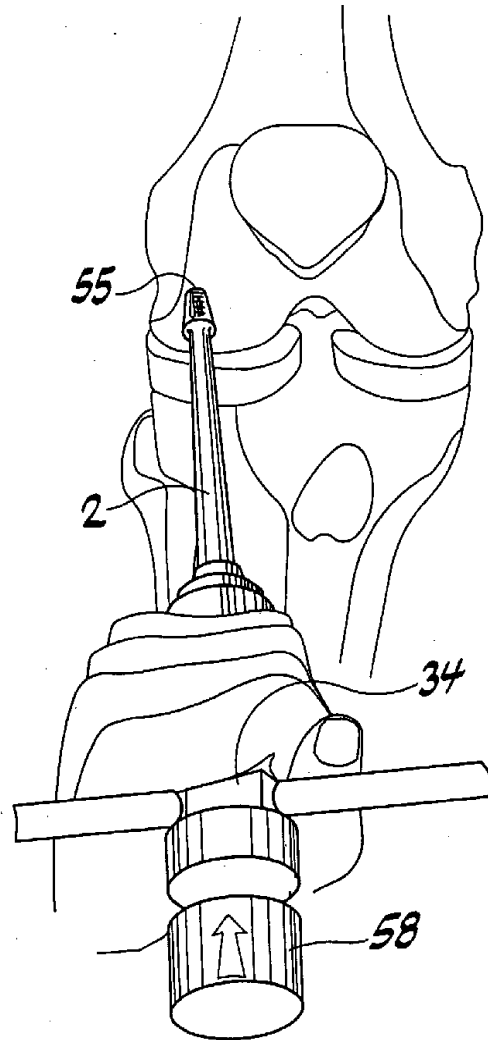

FIG.9



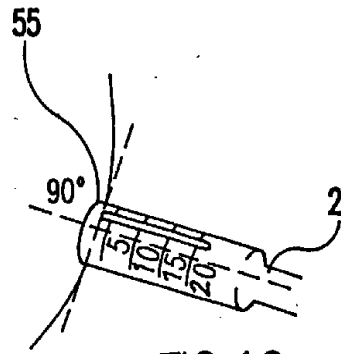

FIG.10

2
3
4
5
6
7

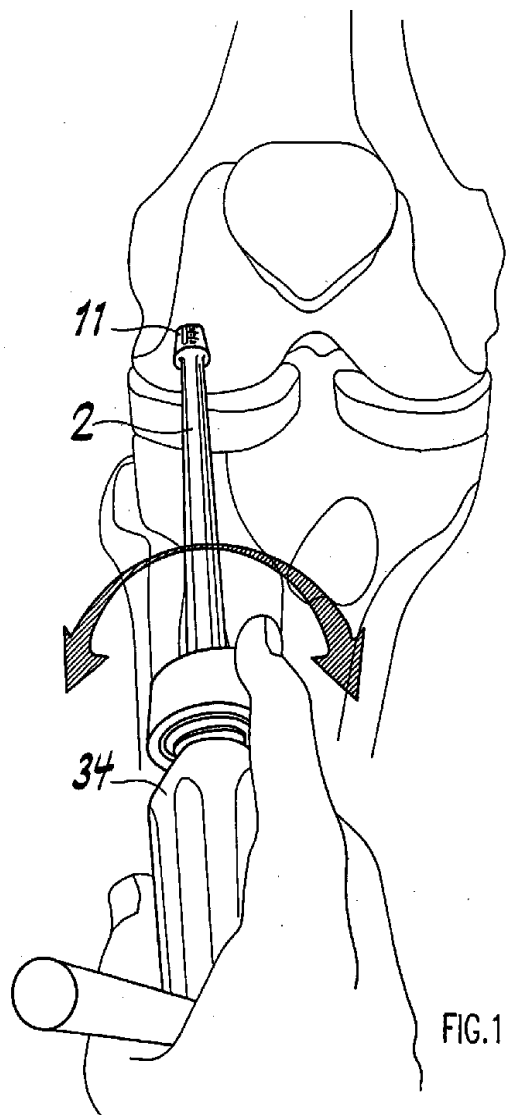

FIG.11

2025 RELEASE UNDER E.O. 14176

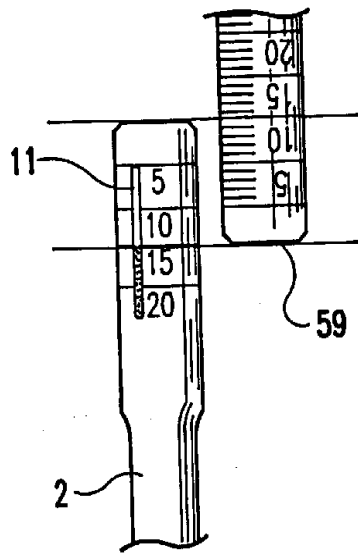

FIG.12

2
5
10
15
20

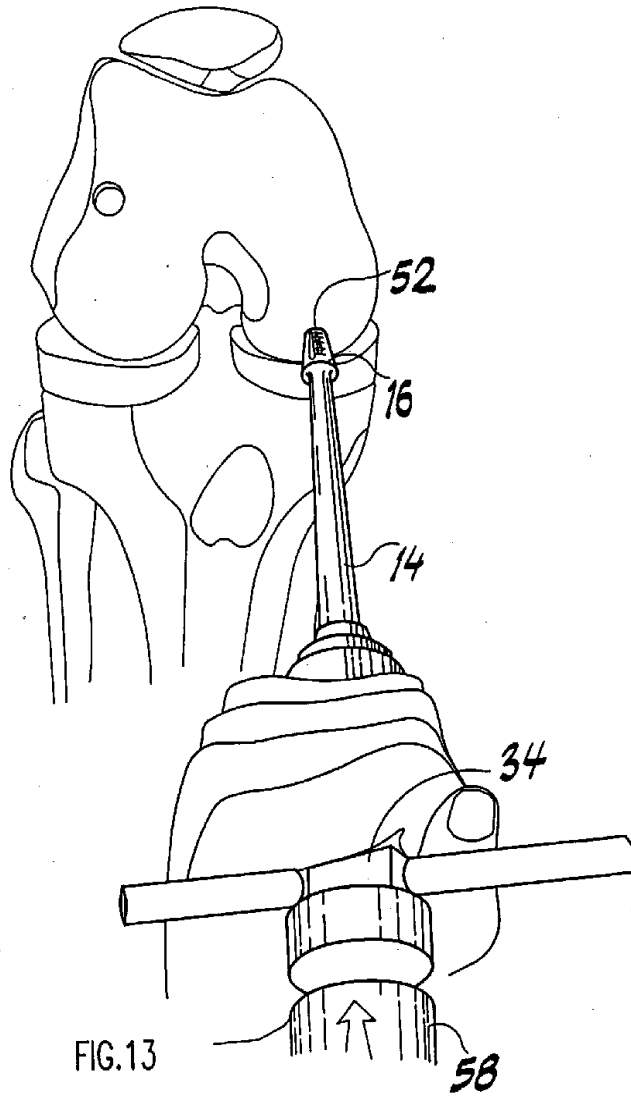

FIG. 13

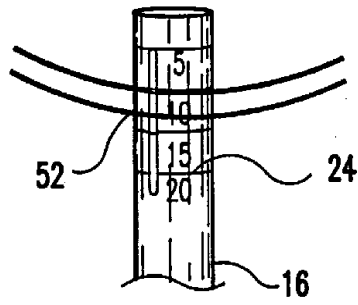

FIG.14

2
4
5
6
4

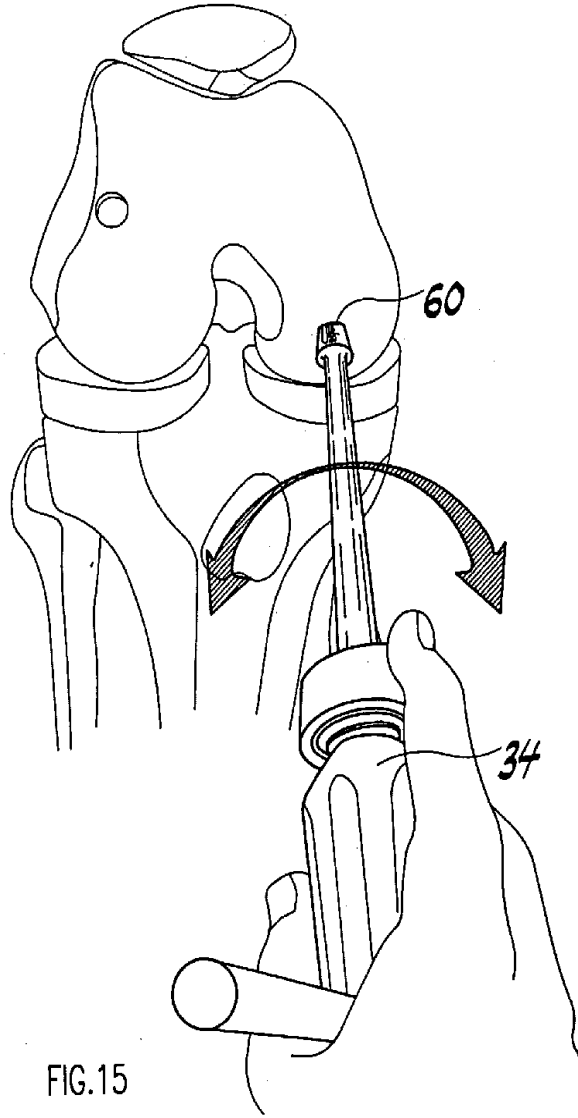

FIG.15

2
4
5
6
7

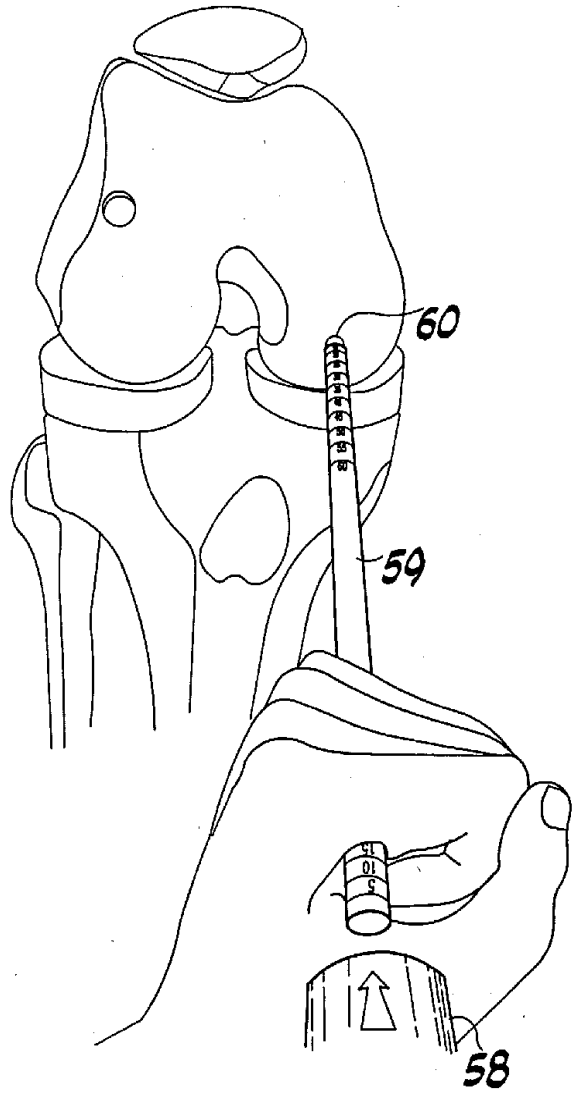

FIG.16

2025

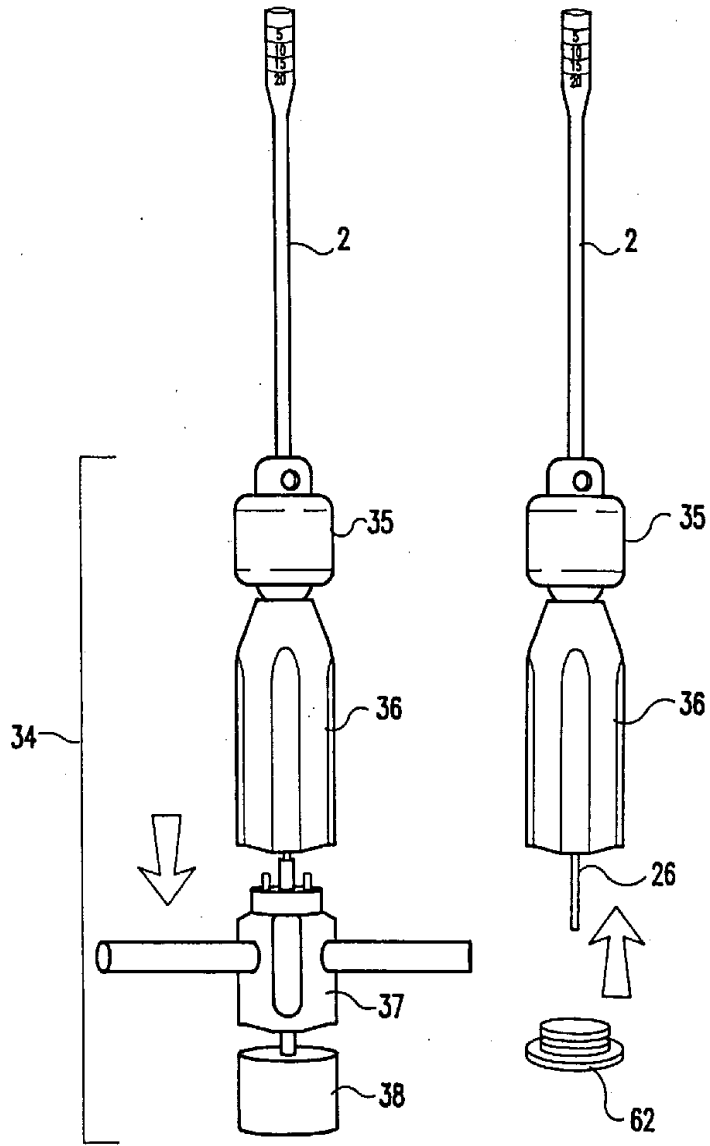

FIG.17

FIG.18



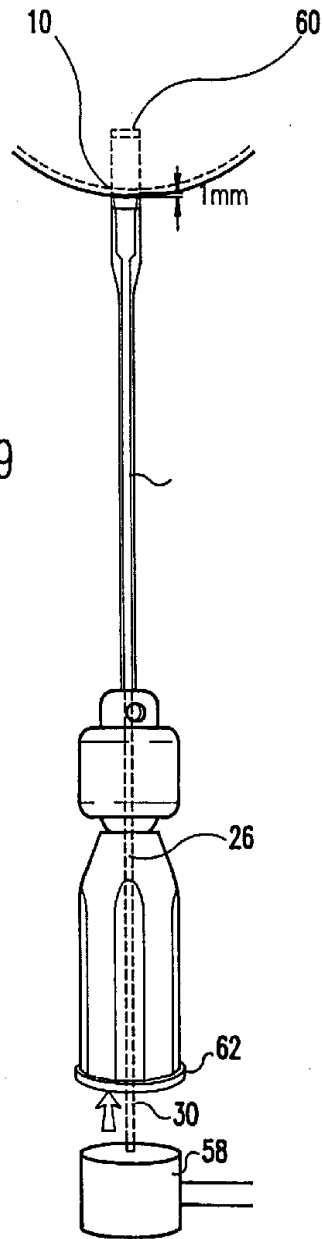
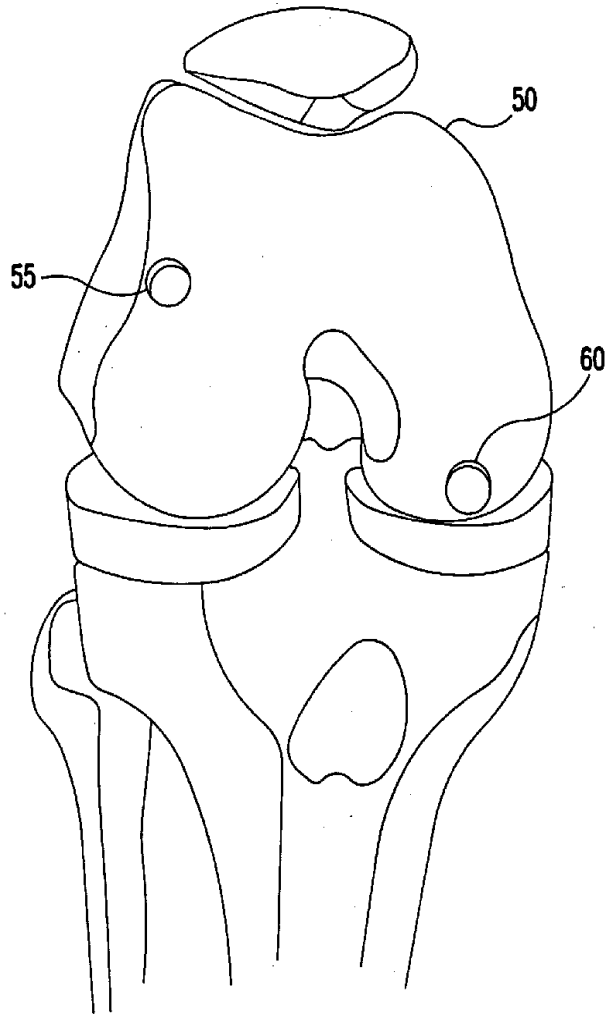

FIG.19

2
A
5
3
A



2
2
5
3
4

FIG.20

2
3
4
5
6
7

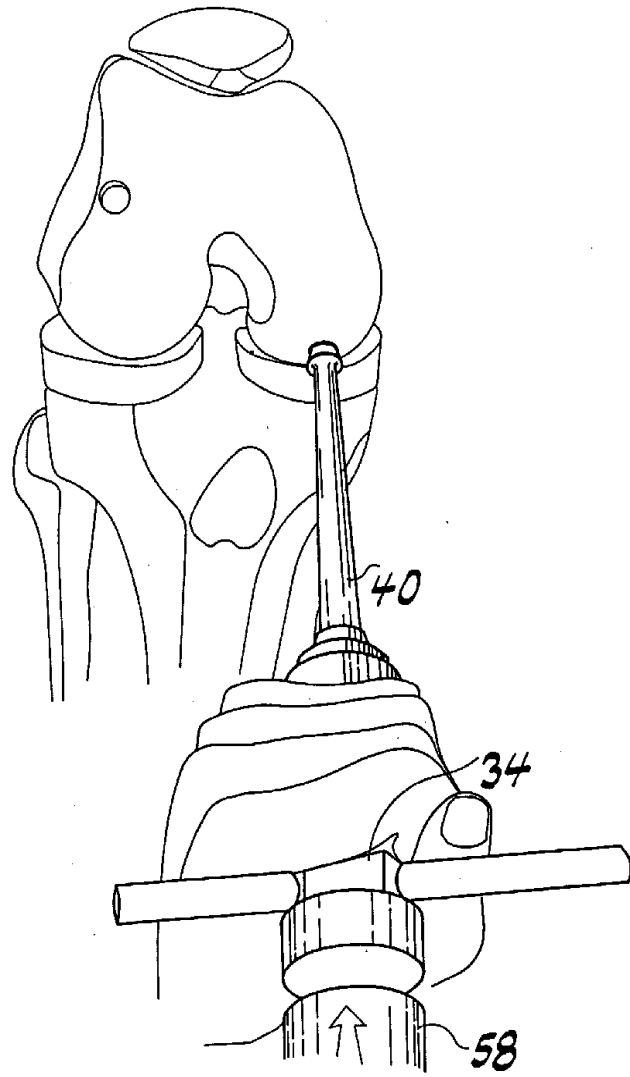

FIG.21

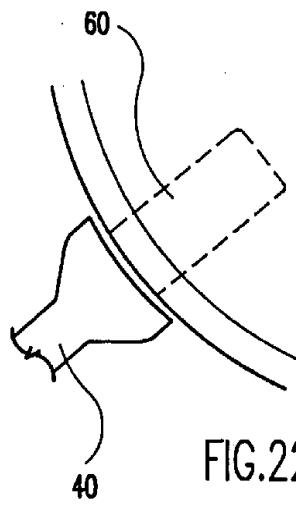

FIG.22

2
3
4
5
6
7
8

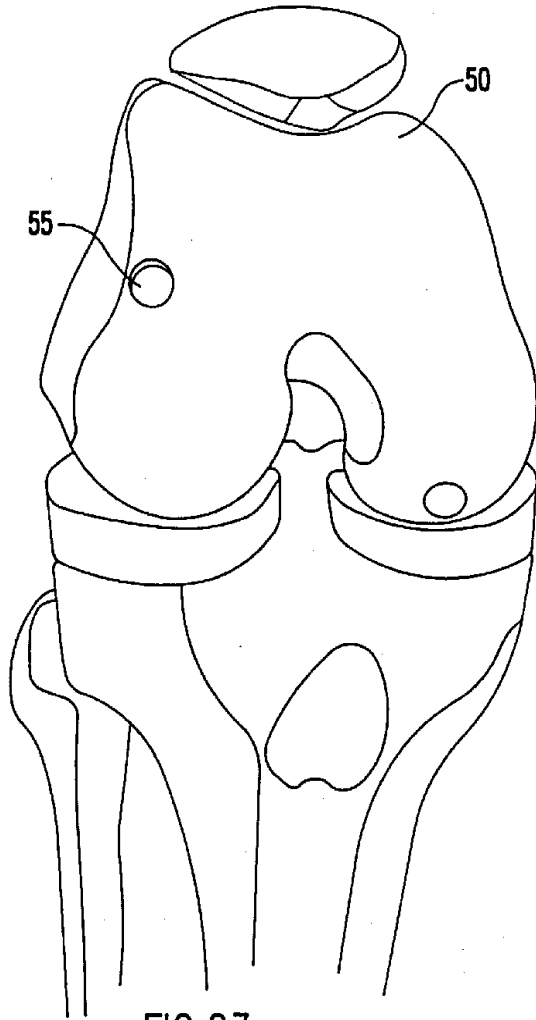

FIG.23

2
3
4
5
6
7

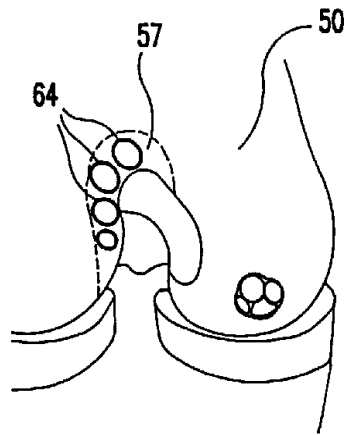

FIG. 24

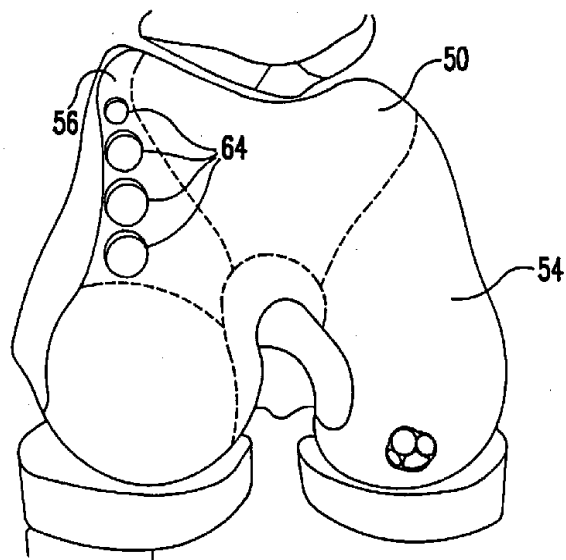

FIG. 25