

(19) (KR)  
(12) (B1)

(51) 。 Int. Cl.<sup>7</sup>  
B25J 19/04

(45)  
(11)  
(24)

2004 05 31  
10-0433272  
2004 05 18

(21) 10-2001-0039385  
(22) 2001 07 03

(65)  
(43)

10-2003-0003498  
2003 01 10

(73)

(72)

3 990 2 5/402

15 1304

2 213-103

7 1615-18(13/5)

881 137-304

(74)

:

(54) 3

Y 3 1, 2 (2,4) ; 1, 2 (2,4) X,  
(20) ; 1,2 (2,4) (3) ; 1, 2 (2,4) (3) Z 6  
1,32) ; 6 (20) 6 (40) ; 6 (3)  
(40) 1,2 (31,32) (50) 6  
, 가 . 3

2

, Pan-Tilting,

1  
2  
3  
4  
5  
6

3

3

3

< >

1 : 2,4 : 1, 2  
3 : 20 : 6  
31,32 : 1, 2 40 : 6  
50 :

가 3 , 3 , 가  
, , 가 2 , ,  
3 가 , , ,  
, 가 , 가

X, Y , Z , 6 가  
, Z 3 3 X, Y 가  
X, Y , 1, 2 (2,4) ; 3 1, 2 (2,4) (2,4) Z 6  
(31,32) (20) ; 1,2 (2,4) (3) ; 1, 2 (2,4) (3) 1,2 6  
(40) ; 6  
(40) 1,2 (20) (31,32) 6 (50)  
1 (2) 2 (4) 3 6 (20) 3 ; 1, 2 (2,4)  
(2,4) (3) Z (Rz), 1, 2 (2,4)

(Ry) 3 X (Rx) 2 ; Z (Rz) X (Rx) Y (Ry) ;  
 1 ( x ) 2 ( y ) 6 (20) 1 3 ( y ) , 1, 2 ;  
 (2,4) (3) Z (Rz) X (Rx) Y (Ry) 4 (2,4) 5 ;  
 , .  
 1 3 , (2,4)  
 (1) X, Y 1, 2 (2,4) , 1, 2 (2,4)  
 (3) Z (3) ,  
 (2,4) 1, 2 (2,4) (3) 6 (20) 3 , 1, 2  
 (2,4) 1, 2 (31,32) 6 (40) 6 (20) 1, 2 (2,4) (40) (50)  
 . 6 (40) 6 (40) (20) 1, 2 (31,32) (40) (50)  
 1, 2 (2,4) (50) 3 , 1, 2 (31,32)  
 (40) 6 (40) (20) (50) , 6  
 1, 2 (2,4) (1) 1, 2 (31,32)  
 2 3 , 6 (20) 3  
 2 (2,4) 1 (2) 2 (4) , 1, 2 (2,4)  
 (3) X (Rx) Z (Rz), (7) (8)  
 (9) Y (Ry) 3 (7) (8) (7) 1 ( x )  
 2 , (3) (8) (7) (9) 2 ( y )  
 , (8) (Pan · Tilting) Z (Rz) X (Rx) , 1 ( x )  
 (Rz), X (Rx) Y (Ry) , 2 ( y ) , (1) 1, 2 , Z ( )  
 3 1, 2 ,  
 3 Z (Rz), X (Rx) Y (Ry) , X (Rx)  $R_x = \frac{Imgx \times Rz}{LF}$   
 ,  
 LF Imgx X .  
 Y (Ry)  $R_y = \frac{Imgy \times Rz}{LF}$  ,  
 Imgy Y .  
 , Z (Rz)  $R_z = \frac{Lb \times LF}{Imgz}$  .  
 Imgz 1, 2 (2,4) X ,  
 Lb 1, 2 (2,4) 3 .  
 4 , X -15° .  
 ( 61), 1, 2 ,  
 62) 가 , X,Y,Z 3 ,  
 1 ( x ) 2 ( y ) ( 63),  
 (20) 1 3 , 1, 2 (2,4) (3) ,

( 64).  
 (3) Z (Rz) X (Rx) Y 1, 2 (Ry) (2,4)  
 ( 65) X (Rx), Y (Ry) Z (Rz) (20)  
 66 (20) 62 1,2  
 , +15° 가 5° (20)  
 5° (20) , 63,64,65 66  
 66 , Z , (20)  
 3 , Z 가 3 ,  
 5 1,2 (71,72) , X  
 Y (73,74)  
 6 가 , Z  
 가 3 , 가 가  
 가 , 가

(57)  
 1.  
 2.  
 3.  
 6 (20) 3 1 (2) 2 (4)  
 1, 2 (2,4) 1 ; 1, 2  
 Z Y (Ry) 3 X (Rx) 2 ; Z (Rz), 1, 2  
 , Z (Rz) X (Rx) 2 ; 1 ( x )  
 1 ( x ) 2 ( y ) 6 3 ; (20) 1 3 , 1, 2  
 (2,4) (3) Z (Rz) X (Rx) Y (Ry) 4 ; (2,4) 5  
 3  
 4.  
 3 2 5 X (Rx) Y (Ry) ,  

$$R_x = \frac{Img_x \times R_z}{LF}$$
 X (Rx) Imgx X ,  
 LF

Y	(Ry)	$Ry = \frac{Imgy \times Rz}{LF}$			
	Imgy		Y	Z	(Rz)
	2				
Z	(Rz)	$Rz = \frac{Lb \times LF}{Imgz}$			
	Imgz		1, 2	(2,4)	X
Lb			1, 2	(2,4)	
					3

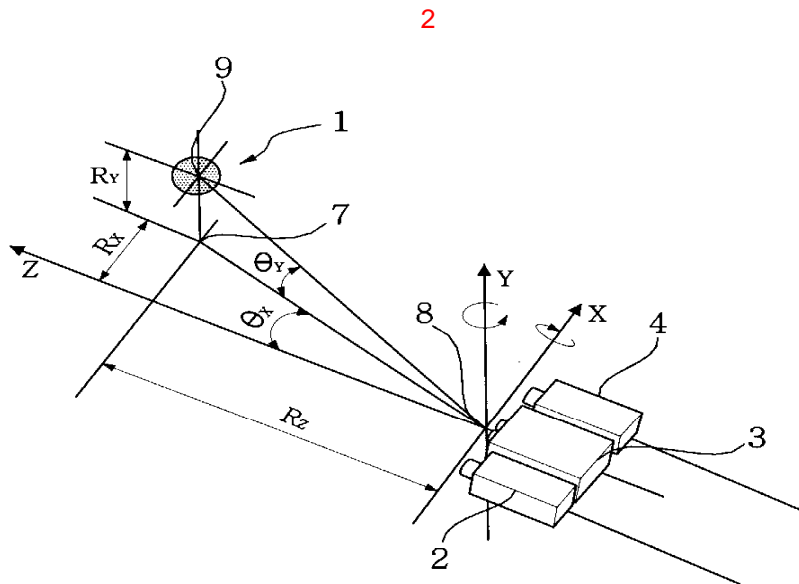
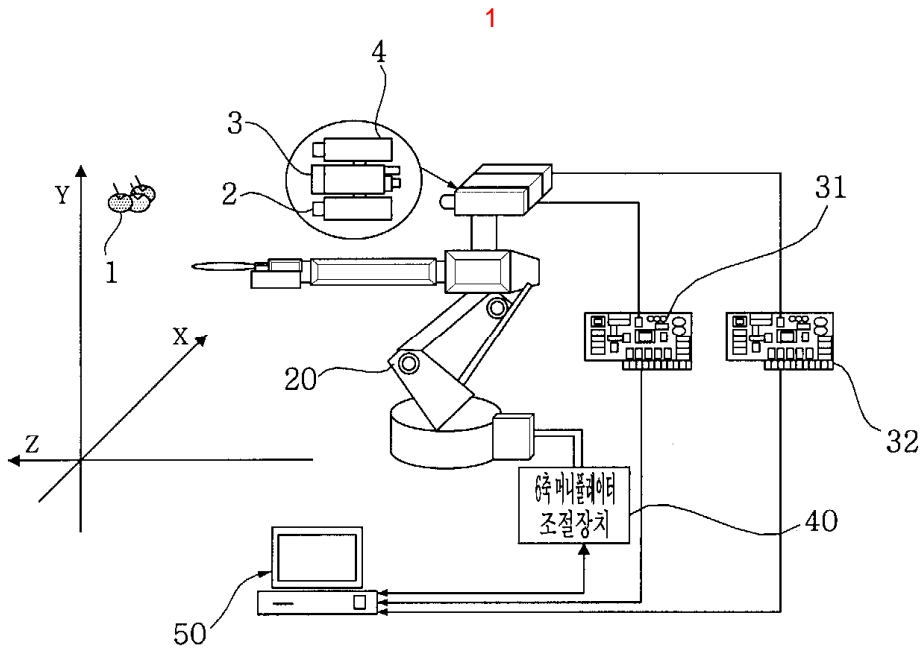

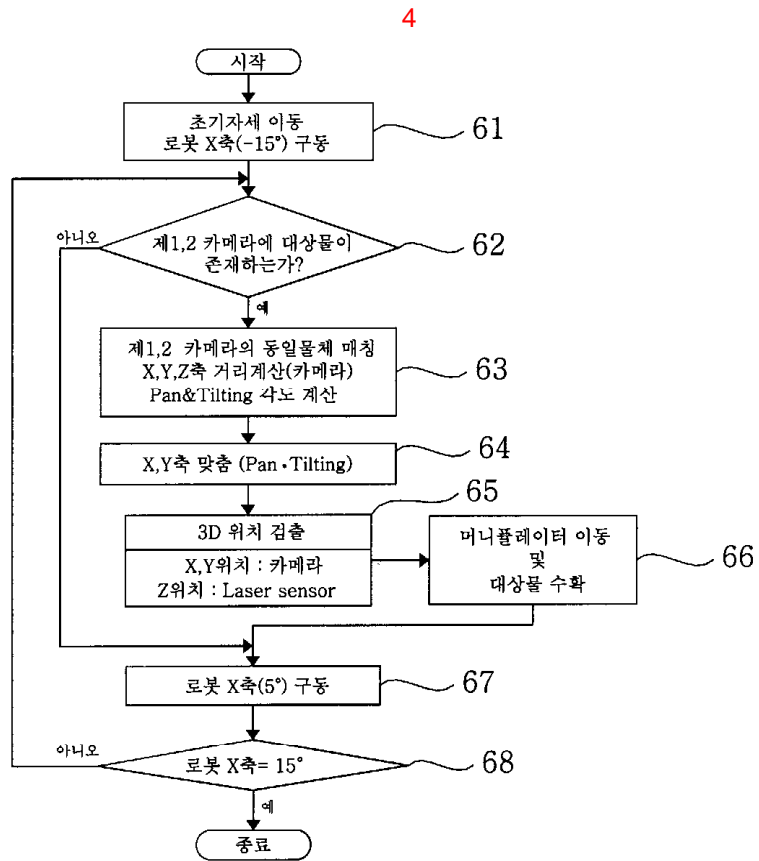
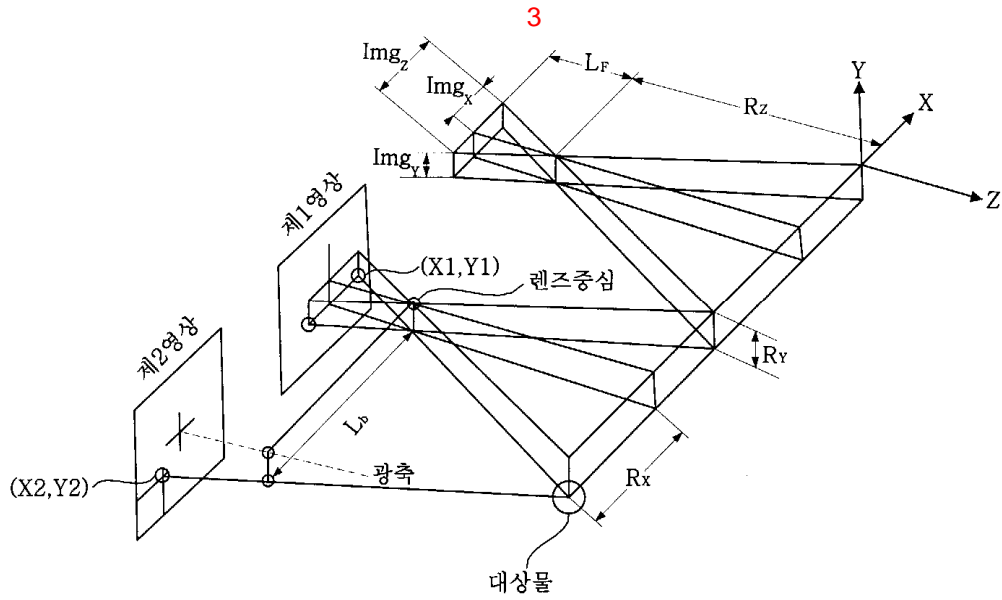

5

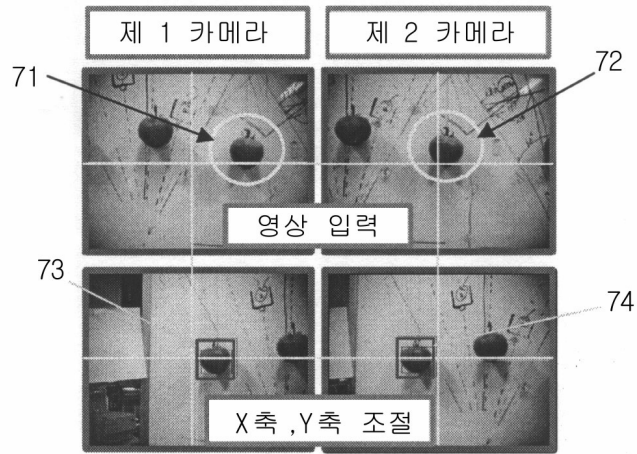

6

