

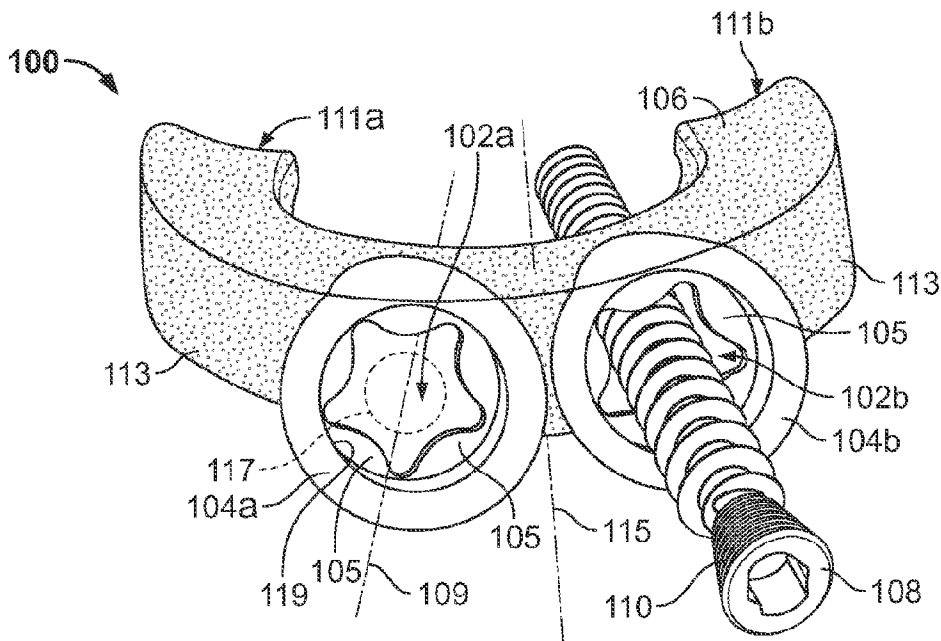

(86) Date de dépôt PCT/PCT Filing Date: 2012/12/06  
 (87) Date publication PCT/PCT Publication Date: 2013/06/13  
 (45) Date de délivrance/Issue Date: 2021/04/20  
 (85) Entrée phase nationale/National Entry: 2014/06/06  
 (86) N° demande PCT/PCT Application No.: US 2012/068219  
 (87) N° publication PCT/PCT Publication No.: 2013/086172  
 (30) Priorité/Priority: 2011/12/07 (US61/567,971)

(51) Cl.Int./Int.Cl. *A61F 2/30* (2006.01),  
*A61B 17/70* (2006.01), *A61F 2/28* (2006.01)  
 (72) Inventeurs/Inventors:  
SHEA, JEFFREY J., US;  
QUINN, NATHANIEL M., US;  
GOLDBERG, DANIEL R., US  
 (73) Propriétaire/Owner:  
SMITH & NEPHEW, INC., US  
 (74) Agent: BORDEN LADNER GERVAIS LLP

(54) Titre : ADJONCTIONS D'IMPLANT ORTHOPEDIQUE  
 (54) Title: ORTHOPEDIC IMPLANT AUGMENTS



(57) Abrégé/Abstract:

Systems, methods, and devices are described for providing orthopedic implant augments having fastener locking mechanisms. The augments include a surface for mating with an implant component and a surface for interfacing with a patient's bone. The fastener locking mechanisms are aligned such that the augment may be locked in a variety of orientations while maintaining close contact with both an implant and a patient's bone. The alignment of the locking mechanisms provides variability and adjustability to the augment to address a variety of bone anatomies and requirements.

(12) INTERNATIONAL APPLICATION PUBLISHED UNDER THE PATENT COOPERATION TREATY (PCT)

(19) World Intellectual Property  
Organization  
International Bureau(10) International Publication Number  
**WO 2013/086172 A1**(43) International Publication Date  
13 June 2013 (13.06.2013)

## (51) International Patent Classification:

A61F 2/30 (2006.01) A61B 17/70 (2006.01)  
A61F 2/28 (2006.01)

## (21) International Application Number:

PCT/US2012/068219

## (22) International Filing Date:

6 December 2012 (06.12.2012)

## (25) Filing Language:

English

## (26) Publication Language:

English

## (30) Priority Data:

61/567,971 7 December 2011 (07.12.2011) US

(71) Applicant: SMITH & NEPHEW, INC. [US/US]; 1450  
Brooks Road, Memphis, TN 38116 (US).(72) Inventors: SHEA, Jeffrey, J.; 2059 Shadowood Cove,  
Memphis, TN 38119 (US). QUINN, Nathaniel, M.; 5314  
Lamb Valley Cove, Arlington, TN 38002 (US). GOLD-  
BERG, Daniel, R.; 377 Meadvale Road, Memphis, TN  
38120 (US).(74) Agents: CHAMBERS, David et al.; Smith & Nephew,  
Inc., 1450 Brooks Road, Memphis, TN 38116 (US).(81) Designated States (unless otherwise indicated, for every  
kind of national protection available): AE, AG, AL, AM,  
AO, AT, AU, AZ, BA, BB, BG, BH, BN, BR, BW, BY,  
BZ, CA, CH, CL, CN, CO, CR, CU, CZ, DE, DK, DM,  
DO, DZ, EC, EE, EG, ES, FI, GB, GD, GE, GH, GM, GT,  
HN, HR, HU, ID, IL, IN, IS, JP, KE, KG, KM, KN, KP,  
KR, KZ, LA, LC, LK, LR, LS, LT, LU, LY, MA, MD,  
ME, MG, MK, MN, MW, MX, MY, MZ, NA, NG, NI,  
NO, NZ, OM, PA, PE, PG, PH, PL, PT, QA, RO, RS, RU,  
RW, SC, SD, SE, SG, SK, SL, SM, ST, SV, SY, TH, TJ,  
TM, TN, TR, TT, TZ, UA, UG, US, UZ, VC, VN, ZA,  
ZM, ZW.(84) Designated States (unless otherwise indicated, for every  
kind of regional protection available): ARIPO (BW, GH,  
GM, KE, LR, LS, MW, MZ, NA, RW, SD, SL, SZ, TZ,  
UG, ZM, ZW), Eurasian (AM, AZ, BY, KG, KZ, RU, TJ,  
TM), European (AL, AT, BE, BG, CH, CY, CZ, DE, DK,  
EE, ES, FI, FR, GB, GR, HR, HU, IE, IS, IT, LT, LU, LV,  
MC, MK, MT, NL, NO, PL, PT, RO, RS, SE, SI, SK, SM,  
TR), OAPI (BF, BJ, CF, CG, CI, CM, GA, GN, GQ, GW,  
ML, MR, NE, SN, TD, TG).

## Published:

— with international search report (Art. 21(3))

(54) Title: ORTHOPEDIC IMPLANT AUGMENTS

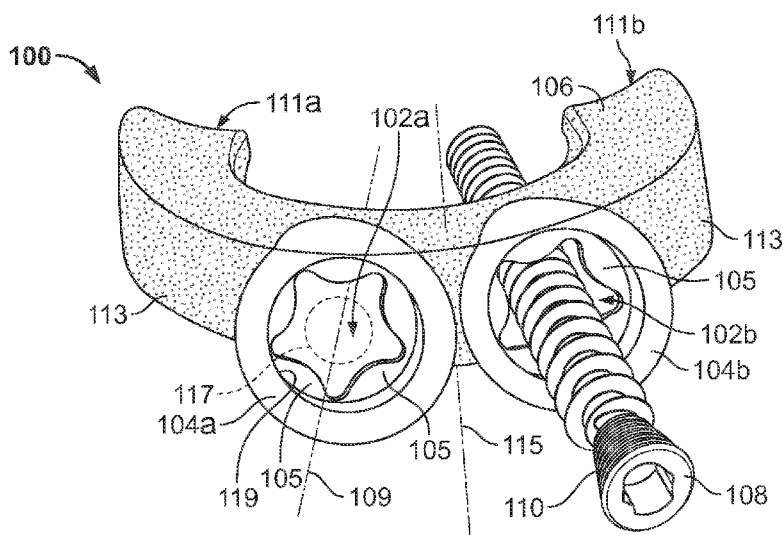

FIG. 1A

(57) Abstract: Systems, methods, and devices are described for providing orthopedic implant augments having fastener locking mechanisms. The augments include a surface for mating with an implant component and a surface for interfacing with a patient's bone. The fastener locking mechanisms are aligned such that the augment may be locked in a variety of orientations while maintaining close contact with both an implant and a patient's bone. The alignment of the locking mechanisms provides variability and adjustability to the augment to address a variety of bone anatomies and requirements.



WO 2013/086172 A1

## ORTHOPEDIC IMPLANT AUGMENTS

5

### Background

[0002] Joints often undergo degenerative changes due to a variety of reasons. When degeneration becomes advanced or irreversible it may become necessary to replace a native joint with a prosthetic joint. Degenerative disease or injury may require replacement of all or a portion of a patient's joint using synthetic material, typically metals, ceramics, or polymer materials. Artificial implants, including hip implants, shoulder implants and knee implants made from these materials, are widely used in orthopedic surgery to strengthen or replace degenerating joints.

15 [0003] In a primary replacement surgery, a patient's native joint is replaced with a prosthetic implant. The implant is designed to integrate with the patient's bone and provide the same function and motion as the native joint that is being replaced. After a primary replacement, it may become necessary to conduct a second or subsequent revision surgery in order to replace a prosthetic joint with a replacement joint which is often larger than the primary replacement. Such surgeries often become necessary due to further degeneration of bone or advancement of a degenerative disease requiring replacement of the implant and diseased bone with a larger, enhanced prosthetic joint, often referred to as a revision prosthesis. For example, bone is often lost around the rim of an acetabulum around a hip implant, and thus may provide less rim coverage to securely hold a press-fit acetabular shell.

20

25 A larger shell can be placed into the acetabulum in a revision surgery to make up for the lost bone.

[0004] In both primary and revision replacement surgeries, a patient's native bone may have defects or voids that a surgeon can fill with bone grafts before inserting an implant. This process may be time consuming and expensive and may subject the patient to health risks. In order to facilitate successful implants in a bone having defects or voids, a surgeon may use  
5 implant augments in conjunction with standard implant components to fill in the voids. Such augments can be coupled or otherwise attached to an outer surface of an implant in the area of a bone void or defect in the native bone. In addition to primary surgery, augments are often used in revision surgeries due to bone degeneration, bone loss or other defects in the degenerative area that necessitates the revision surgery.

10 [0005] A degree of variability in implant augments may be desired, as the location and nature of the native bone and the bone defects vary from patient to patient. Especially when defects or voids in the bone are present, it is preferable for a surgeon to have the ability to adjust the implant to fit the bone, rather than adjusting the bone to fit a rigid implant. Adjusting the implant or implant augments allows for conservation of native bone rather than  
15 requiring reaming or other removal of a patient's native bone in preparation for implant placement. Conserving bone supplements the support that the bone gives to the implant component. Especially in the cases of diseased bone or damaged bone in revision surgery, any bone that is removed to prepare for the implant may prove detrimental to the integrity of the bone and its ability to withstand significant forces following implantation.

20 [0006] To supplement fixation of orthopedic implants into native bone, implants can incorporate mechanical fasteners, such as screws, and locking mechanisms that engage the screws in a locked configuration relative to both the bone and the implant. Such fasteners and locking mechanisms can be used to hold the implant in place and reduce detrimental effects caused by implant movement. While the locking mechanisms provide a steady hold  
25 between the fastener and the implant, the nature of the locking mechanisms often limits the orientation in which the fastener can be locked. The locking mechanisms often require that the fastener be inserted in a certain direction along a given axis in order to engage the locking mechanism of the implant.

[0007] Implementing locking screws and locking mechanisms into implant augments may  
30 be desirable to increase the hold of the implants and augments into native bone. The locking mechanisms may also, however, cut down on variability of augments and the number of orientations in which an augment can be inserted into a bone, given the limited function of the locking mechanisms. Incorporating a locking mechanism into an augment may require a surgeon to choose between placing the augment in an orientation with a strong hold of the

locking mechanisms or placing the augment in an orientation that creates better contact with the native bone into which the augment is placed, but creates a weaker engagement of the locking mechanism. This can create problems and result in inadequate fixation of an augment or an undesirable positioning of the augment in native bone.

5 Summary

[0008] Disclosed herein are systems, devices and methods for providing implant augments that allow for intraoperative variability and supplemented fixation into native bone. In general, the systems, devices and methods provide augments that include one or more locking mechanisms that engage mechanical fasteners and fix the augments into bone. The locking mechanisms are configured such that the augment may be inserted in a wide variety of orientations, allowing the locking mechanism to engage a mechanical fastener in each of the possible orientations. These augments provide a combination of adequate bone fixation and locking engagement with mechanical fasteners while still maintaining close contact with both the patient's native bone and an implant placed into that bone.

10 [0009] In some embodiments, an orthopedic device, such as an augment, includes a first surface having a mating face that is configured to mate with an implant and an opening configured to receive a fastener. The opening includes a plurality of fins that are disposed in a plane that is not parallel to the mating face of the first surface.

15 [0010] In certain implementations, the opening in the device includes first and second ends, and the opening is configured to receive a fastener inserted into the first end when the device is in a first orientation and is configured to receive a fastener inserted into the second end when the device is in a second orientation. The fins are disposed between the first and second end of the opening and are configured to lock a fastener in a first locked configuration when the device is in the first orientation and are configured to lock a fastener in a second locked configuration when the device is in the second orientation.

20 [0011] The mating face is configured to mate with an implant when the device is in each of the first and second orientations. The orthopedic device also includes a second surface configured to mate with the patient's bone or tissue, and the second surface is configured to mate with patient's bone or tissue when the device is in each of the first and second orientations.

25 [0012] In certain implementations, the plane in which the fins are disposed is substantially perpendicular to the mating face. The fins are configured to engage a fastener inserted along

any one of a plurality of axes and lock the fastener in a plurality of locking configurations corresponding to the plurality of axes.

[0013] In some embodiments, an orthopedic device includes a means for mating with an implant, a means for receiving a fastener and a means for locking a fastener disposed in a plane that is not parallel to the means for mating with an implant.

#### Brief Description of the Drawings

[0014] The foregoing and other objects and advantages will be more appreciated fully from the following further description thereof with reference to the accompanying drawings.

These depicted embodiments are to be understood as illustrative, and not as limiting in any way:

[0015] FIGS. 1A and 1B show perspective views of an illustrative augment having a fastener locking mechanism;

[0016] FIG. 2 depicts one of the locking mechanisms of the augment shown in FIGS. 1A and 1B;

[0017] FIGS. 3A-3C show various illustrative orientations in which the augment of FIGS. 1A and 1B may be attached to an implant;

[0018] FIG. 4 shows a perspective view of an illustrative augment having a fastener locking mechanism.

#### Detailed Description

[0019] To provide an overall understanding of the systems, devices and methods described herein, certain illustrative embodiments will now be described. In general, the systems, devices and methods provide augments that include one or more locking mechanisms that engage mechanical fasteners and fix the augments into bone. For the purpose of clarity and illustration the systems, devices and methods are described with respect to orthopedic implant augments but it will be understood by one of ordinary skill in the art that the systems, devices and methods disclosed herein may be adapted and modified as appropriate, and that the systems, devices and methods described herein may be employed in other suitable applications such as where other types of implants or augments, or may utilize other types of locking mechanisms, and that such other additions and modifications will not depart from the scope hereof.

[0020] The augments described herein provide a surgeon with adjustability and variability to accommodate a wide variety of bone anatomies. The augments preferably maintain a close

interface with both an implant and a patient's surrounding bone while allowing the surgeon to place the augments in a wide variety of positions in order to suit different bone anatomies. In addition, the augments incorporate locking mechanisms that lock mechanical fasteners into the augment in a locking configuration. These locking mechanisms are disposed and aligned  
5 such that the movement of the augment from one orientation to a variety of other orientations does not materially interfere with the locking mechanism and also does not materially interfere with the close interfaces with the implant and surrounding bone.

[0021] FIGS. 1A and 1B show perspective views of an implant augment 100. The augment 100 has a generally horseshoe shape with two legs 111a and 111b extending below a top  
10 surface 113. The augment includes two openings 102a and 102b that extend from the top surface 113. The two openings 102a and 102b are configured to receive a mechanical fastener, such as screw 108, to fix the augment 100 to bone into which the augment is implanted.

[0022] The inner surface of the augment 100 has a mating face 106. The mating face 106 is  
15 designed to match the shape of an exterior surface of an implant, such as an acetabular shell or cage. The mating face 106 extends down both of the legs 111a and 111b and has an arcuate contour and smooth face to maintain a close contact with a given implant when the augment 100 is positioned in a variety of orientations and rotations.

[0023] Each of the openings 102a and 102b has a first end 104a and 104b, respectively, that  
20 extends above the top surface 113 of the augment. Each opening 102a and 102b includes a plurality of fins 105 disposed therein that create a locking mechanism within the openings. The openings 102a and 102b are shown in FIGS. 1A and 1B with five fins 105 extending inward from interior surfaces of the openings 102a and 102b, but any other suitable number of fins may be used. A longitudinal axis, for example axis 109 shown in FIG. 1A, runs  
25 through each of the openings 102a and 102b. The longitudinal axis 109 is substantially parallel to the flat surface of the mating face 106. In this orientation, the fins 105 and both openings 102a and 102b are disposed in a plane that is normal to the axis 109. Thus, the plane in which the fins 105 are disposed is also substantially perpendicular to the smooth mating face 106.

[0024] The fins 105 are configured to engage a mechanical fastener, such as the screw 108,  
30 to lock the fastener into the augment 100 when the fastener is inserted into either of the openings 102a or 102b. The fins 105 extend inward from the interior surface 119 of the opening 102a toward the longitudinal axis that runs through the center of the opening. When the screw 108 is inserted into the opening, the fins 105 engage the threading 110 on the head

of the screw 108. The engagement between the fins 105 and the threading 110 locks the screw 108 into either of the openings 102a or 102b. The interaction between the fins 105 and the threading 110 resists removal of the screw 108.

5 [0025] In addition to locking a fastener in place, the openings 102a and 102b allow for polyaxial alignment of fasteners inserted into one of the openings. The width of the openings and space between the fins 105 allows for movement of the screw 108 to align along an axis through the opening that is offset from the axis 109. The dotted outline 117 shown within opening 102a indicates the width of the screw 108, and shows the extra spacing between the fins 105 that allows the screw to move freely. With this extra space, a screw can be twisted  
10 to align with a variety of axes offset from the axis 109. Because the fins 105 are disposed around the inner perimeter of the opening 102a, the locking engagement between the fins 105 and the threading 110 is maintained at any of the varieties of axes along which the screw 108 may be inserted. Thus, the openings 102a and 102b and the locking fins 105 not only allow for the augment 100 to lock onto a fastener and connect the augment to the bone, but also  
15 may accommodate fasteners inserted at any of a variety of angles along any variety of axes in order to further enhance the variability and adjustability of the augment 100.

[0026] The orientation of the openings 102a and 102b relative to the mating face 106 allows for the augment 100 to be implanted in a variety of orientations while still maintaining adequate locking engagement between the screw 108 and one of the openings. When the  
20 augment is implanted in a certain chosen orientation, the alignment of the openings 102a and 102b also allows close contact to be maintained between the mating face 106 and an implant, as well as allowing for close contact to be maintained between an exterior surface of the augment 100 and the patient's native bone. For example, the augment 100 shown in FIG. 1A may be rotated about the axis 115, which runs perpendicular to the mating face 106. Such  
25 rotation produces a variety of orientations in which the augment can be placed with the mating face 106 facing substantially the same direction while the openings 102a and 102b are rotated. When the augment 100 is rotated around axis 115, maintaining the position of the mating face 106 in a single direction will allow the mating face 106 to continue to contact an implant next to which the augment 100 is placed.

30 [0027] To further facilitate the variability of the augment 100 while maintaining the orientation of the mating face 106, the openings 102a and 102b are able to receive and lock a fastener inserted into either end of the openings. FIG. 1B shows a second perspective view of the augment 100 with second ends 107a and 107b of the openings 102a and 102b, respectively, exposed. As shown in FIG. 1B, a fastener, such as the screw 108, can also be



inserted through the second ends 107a and 107b of the openings. The openings 102a and 102b and the fins 105 are designed such that the locking engagement between the fins 105 and threads 110 of the screw 108 is not unidirectional, and the locking interaction can occur regardless of the direction in which the screw 108 is inserted into one of the openings. As  
5 shown in FIG. 1B, the screw 108 passes through the opening 102b such that the threads 110 are able to engage the fins 105, similar to the orientation shown in FIG. 1A, in which the screw 108 is inserted into the first end 104 of the opening 102b.

[0028] The orientation of the openings 102a and 102b and the locking fins 105 relative to the mating face 106 allows for the augment 100 to maintain a close interface with an implant  
10 when the screw 108 is inserted to the second ends 107a or 107b of the opening. Because the fins 105 are not parallel to the mating face 106, the rotation around the axis 105 shown in FIG. 1A, and insertion of the screw 108 into the second end 107b of opening 102b, can be achieved without affecting the positioning of the mating face 106. Likewise, the bone interface surface 112 is maintained in a position to contact the patient's native bone when the  
15 augment 100 is rotated around axis 115. Like the mating faces 106, the bone interface surface 112 maintains close contact with the bone when the screw 108 is inserted through either the first ends 104a or 104b or second ends 107a or 107b of the openings. This alignment of the openings 102a and 102b allows a wide range of variability in the orientations in which a surgeon can insert the augment 100 while still maintaining the desired  
20 contact between the mating face 106 and an implant and the bone interface surface 112 and the patient's bone, and also maintaining the ability to lock the screw 108 into the opening. The polyaxial nature of the openings 102a and 102b and the locking fins 105 further supplements the wide variability of the augment 100.

[0029] The orientation of the fins 105 relative to the mating face 106 and the bone interface  
25 surface 112 provides variability in placing the augment while maintaining the desired positioning of the mating face 106 with an implant and the bone interface surface 112 with a patient's bone. FIG. 2 further illustrates the orientation of the fins 105 in a top view of the opening 102a of the augment 100. As shown in FIG. 2, the fins 105 are disposed on the interior of the opening 102a, extending inwardly from the interior surface 119 of the opening  
30 toward the center longitudinal axis 109 of the opening. The fins 105 extend substantially perpendicular to the interior surface 119, and thus each of the fins 105 is substantially disposed within a plane 114 shown in FIG. 2. The plane 114 is normal to the longitudinal axis 109 of the opening 102a and shows the alignment of the fins 105 relative to the mating face 106. As shown in FIG. 2, the plane 114 intersects the mating face 106 and is not parallel

to the mating face 106. In the embodiment shown in FIG. 2, the plane 114 is perpendicular to the mating face 106, but in other embodiments, the plane may be skewed slightly so as not to be completely perpendicular to the mating face.

[0030] In general, the orientation of the fins 105 relative to the mating face 106 allows the opening 102a to receive a fastener at a variety of angles, positions and directions. In particular, because the fins 105 are disposed in the plane 114 substantially perpendicular to the mating face 106, a screw may be received by the opening 102a either through the first end 104a of the opening, shown in FIG. 2, or through the second end 107a of the opening, not shown in FIG. 2, that is from the back or the front of the opening. This allows the surgeon to more flexibly select the location and direction of screw insertion. It also allows the mating face 106 to remain in close contact with an implant regardless of the end of the opening 102a into which the screw is inserted. This close contact would not be possible if, for example, the opening 102a and fins 105 were aligned parallel with the mating face 106, as opposed to the perpendicular alignment shown in FIG. 2. If the opening and fins were parallel to the mating face, the screw would break the plane of the mating face. This would prevent a close contact between the mating face and an implant, as a screw could not be inserted in the direction shown by arrow A in FIG. 2 with the mating face 106 placed in close contact with an implant. This complication is avoided by the orientation of the fins 105 and opening 102a, as the screw can be inserted from either end of the opening when the mating face 106 is maintained in close contact with an implant.

[0031] The variability afforded by the augment 100 provides a surgeon with the ability to adjust the augment to fit specific needs or bone anatomy of a particular surgery. This variability allows the surgeon to make decisions intraoperatively and determine the orientation that best fills the need for the surrounding bone anatomy. For example, the surgeon may view the surgical field with an implant placed in the patient's bone and determine the optimal orientation of the augment to fill a defect or void in the patient's bone. The surgeon is then able to position the augment in the desired orientation and insert a screw into whichever end of the opening to the augment will better engage the patient's bone and lock the screw in a locked configuration. Alternatively, the variability of the augment gives a surgeon the ability to decide pre-operatively the orientation of the augment that best fits the needs of the patient's bone. In some approaches, this may require multiple different augments that allow the surgeon to achieve one of the selected orientations. However, the variability of the augment 100 allows the surgeon to use just the single augment to achieve whichever orientation he or she desires. Whether the decision is made pre-operatively or intra-

operatively, the surgeon is able to position the augment in the orientation that best fits the needs of the native bone while maintaining a close contact between a mating face of the augment and the implant, as well as a close contact between a bone interface surface of the augment and the patient's surrounding bone. All of these interactions are maintained while at  
5 the same time allowing a screw to be inserted and locked into the augment in whichever orientation is selected. The polyaxial nature of the openings and locking mechanisms of the augment further contribute to the ability of the surgeon to locate the augment and screws as desired.

[0032] FIGS. 3A-3C show three configurations that highlight variability of the augment  
10 100. FIG. 3A shows a first configuration 150 in which the augment 100 is implanted with an acetabular shell. The augment 100 is shown in FIG. 3A abutting a rim 116 of the implanted shell, with the rim 116 having an exterior surface 118 and an interior surface 120. In the configuration shown in FIG. 3A, the augment 100 is placed against an exterior surface of the rim 116. In this orientation, the two legs 111a and 111b, not shown in FIG. 3A, extend  
15 downward away from the top surface 113. This orientation may be desired, for example, if there is a screw implanted with the shell and holding the shell into a patient's bone. By inserting the augment 100 in the orientation shown in FIG. 3A, the two legs 111a and 111b are able to pass on either side of the screw and allow the augment 100 to be implanted without interfering with the screw.

[0033] Rather than the augment orientation shown in FIG. 3A, a surgeon may desire to place the augment 100 in alternate configurations. The variability of the augment 100 allows the surgeon to rotate the augment 100 about the axis 115, shown in FIG. 3A in order to achieve other augment orientations while maintaining the contact between the mating face  
20 106 of the augment and the exterior surface 118 of the implant. FIG. 3B shows one alternate orientation in which the augment 100 is rotated 180 degrees about axis 115 from the orientation shown in FIG. 3A. In the orientation 160, shown in FIG. 3B, the augment is placed such that the top surface 113 of the augment is positioned down into the bone, and the two legs 111a and 111b are facing up toward the top rim 116 of the implant. In this  
25 orientation, the close contact is maintained between the mating surface 106 of the augment and the exterior surface 118 of the implant. Additionally, the location of the bone interfacing surface 112 is maintained facing away from the native implant such that it is able to contact a  
30 patient's native bone. The orientation 160 may be desired if, for example, the surgeon determines that there is a bone void or a need for more support in lower portions of the implanted shell. By positioning the augment 100 in the orientation 160, the surgeon can

position the top portion of the augment 100, which has more material and more support, down toward the bottom of the native implant, where that support is needed.

[0034] To facilitate the placement of the augment 100 in the orientation 160, the screws 161a and 161b are inserted into the second ends 107a and 107b of the openings 102a and 102b. The polyaxial and multidirectional nature of these openings allows for the screws to be locked into the openings in this alternate orientation. Because the openings and the locking mechanisms work in multiple directions, the orientation 160 may be achieved while keeping the desired contact with both the patient's bone and the native implant, and still taking advantage of the available locking mechanism of the augment 100.

[0035] In addition to the two orientations shown in FIGS. 3A and 3B, any intermediate rotation that may be desired can be achieved with the augment 100. FIG. 3C shows a third orientation 170 of the augment 100 placed against the native implant. As shown in FIG. 3C, the augment 100 is rotated 90 degrees about the axis 115 from the orientation shown in FIG. 3B. This rotation positions the implant such that leg 111a faces toward the top of the implant rim 116. In the orientation 170, the close contact between the mating face 106 of the augment and the exterior surface 118 of the rim 116 is again maintained. Also, the positioning of the bone interface surface 112 is maintained facing away from the rim 116 so that it may contact the patient's native bone. The screw 171 is inserted into the second end 107a of the opening 102a and extends through the opening beyond the top surface 113 of the augment. Because the center axis 109 of the opening 102a does not extend away from the patient's native bone as it does in FIGS. 3A and 3B, placement of the screw may be more difficult than screw placement in the orientation 150 and 160. The polyaxial nature of the opening 102a and the locking fins that maintain the screw in the opening 102a can facilitate the placement of the screw off-axis from the center axis 109 to still allow the surgeon to secure the screw into the patient's bone and lock the screw in its orientation with the augment 100.

[0036] While the augment 100 is shown having a horseshoe shape to highlight certain advantages and applications of the augment, alternative embodiments of the augment may take any form or shape that is suitable for a particular application. FIG. 4 shows an augment 200 which has an alternate shape. The augment has a full mating face 206 that does not have a gap, as the mating face 106 of augment 100 has between the legs 111a and 111b. This shape augment may be desirable for applications in which there is a large bone void to fill, or when there are no screws in a native implant to be avoided. The augment 200 includes a top surface 213 into which two openings 202a and 202b pass. Each of the openings 202a and

202b include locking fins 205 disposed from an interior surface of the opening. Similar to the openings and locking fins discussed above with respect to augment 100, the openings 202a and 202b can receive a fastener through either of the first ends 204a or 204b of the opening or second ends, which are not shown in FIG. 4. The fins 205 are disposed in a plane  
5 that is not parallel to the mating face 206. Thus, the multidirectional, polyaxial nature of the openings 202a and 202b and the fins 205 allow the augment 200 to be placed in a variety of orientations that maintain close contact between the mating face 206 and an implant, and also allow a surgeon to utilize the locking mechanism of the openings 202a and 202b.

[0037] It is to be understood that the foregoing description is merely illustrative, and is not  
10 to be limited to the details given herein. While several embodiments have been provided in the present disclosure, it should be understood that the disclosed systems, devices and methods and their components may be embodied in many other specific forms without departing from the scope of the disclosure.

[0038] Variations and modifications will occur to those of skill in the art after revealing this  
15 disclosure, where disclosed features may be implemented in any combination and subcombinations (including multiple dependent combinations and subcombinations), with one or more other features described herein. The various features described are illustrated above, including any components thereof, may be combined or integrated in other systems, moreover, certain features may be omitted or not implemented.

[0039] Examples of changes, substitutions and alterations are ascertainable by one skilled  
20 in the art and to be made without departing from the scope of the information disclosed herein.

## CLAIMS:

1. An orthopedic device comprising:
  - a first surface having a mating face configured to mate with an implant, the mating face having an arcuate contoured shape that mates with an exterior surface of an implant;
  - a second surface adjacent to the first surface and intersecting the first surface at an edge, the second surface comprising an opening extending through the second surface to an opposite surface, wherein the opening is configured to receive a fastener, said opening comprising a plurality of fins disposed in a plane that is not parallel to the mating face; and
  - a bone interface surface, the bone interface surface and the mating face positioned on opposite sides of the second surface, and the plane in which the plurality of fins are disposed is not arranged parallel to the bone interface surface; and
  - wherein at least a portion of the first surface is formed from a porous material; and
  - wherein the arcuate contoured shape of the mating face extends inwardly in a direction generally toward the bone interface surface.
2. The device of claim 1, wherein the opening is configured as a through hole and the opening comprises a first end in the second surface and a second end in a surface opposite the second surface.
3. The device of claim 2, wherein the opening is configured to receive a fastener inserted into the first end in the second surface when the device is in a first orientation and is configured to receive a fastener inserted into the second end opposite the second surface when the device is in a second orientation.
4. The device of claim 3, wherein the fins are disposed between the first and second ends of the opening.
5. The device of claim 3, wherein the fins are configured to lock a fastener in a first locked configuration when the device is in the first orientation and are configured to lock a fastener in a second locked configuration when the device is in the second orientation.

6. The device of claim 3, wherein the mating face is configured to mate with an implant when the device is in each of the first and second orientations.
7. The device of claim 1, wherein, relative to a direction of the longitudinal axis of the opening, the bone interface surface has a shape that is different than the contoured shape of the mating face.
8. The device of claim 1, wherein the plane is substantially perpendicular to the mating face.
9. The device of claim 1, wherein the fins are configured to engage a fastener inserted along any one of a plurality of axes and lock the fastener in a plurality of locking configurations corresponding to the plurality of axes.
10. An augment device comprising:
  - an inner surface with a mating face, at least a portion of the inner surface comprising a porous material, the mating face having a first contoured shape that mates with an exterior surface of an implant;
  - a bone interface surface opposite the mating face, the bone interface surface having a second contoured shape that mates with a patient's bone or tissue, the first contoured shape being different than the second contoured shape;
  - a top surface connected to the inner surface and the bone interface surface, wherein the inner surface, the bone interface surface, and the top surface form two legs having a generally horseshoe shape; and
  - at least one opening extending from the top surface, the at least one opening including a locking mechanism comprising a plurality of fins, the first contoured shape having an arcuate contour that extends inwardly in a direction generally toward the bone interface surface.
11. The augment device of claim 10, wherein the bone interface surface is not arranged parallel to a plane about which the plurality of fins are disposed.
12. The augment device of claim 10, wherein the orientation of the at least one opening is relative to the mating face.

13. The device of claim 10, wherein the mating face is configured to mate with an implant when the device is in each of the first and second orientations.
14. The device of claim 10, wherein at least one of the bone interface surface and the top surface comprise a porous material portion.
15. The device of claim 10, wherein the plurality of fins are disposed in a plane arranged substantially perpendicular to the mating face.
16. The device of claim 10, wherein the plurality of fins is configured to engage a fastener inserted along any one of a plurality of axes and lock the fastener in a plurality of locking configurations corresponding to the plurality of axes.
17. The device of claim 10, wherein the at least one opening is configured as a through hole and the opening comprises a first end in the top surface and a second end in a surface opposite the top surface.
18. The device of claim 17, wherein the opening is configured to receive a fastener inserted into the first end in the top surface when the device is in a first orientation and is configured to receive a fastener inserted into the second end opposite the top surface when the device is in a second orientation.
19. The device of claim 17, wherein the plurality of fins is disposed between the first and second ends of the opening.
20. The device of claim 17, wherein the plurality of fins is configured to lock a fastener in a first locked configuration when the device is in the first orientation and is configured to lock a fastener in a second locked configuration when the device is in the second orientation.
21. An augment device comprising:
  - an inner surface with a mating face, at least a portion of the inner surface comprising a porous material, the mating face having a first contoured shape that mates with an exterior surface of an implant;



a bone interface surface opposite the mating face, the bone interface surface having a second contoured shape that mates with a patient's bone or tissue, the first contoured shape being different than the second contoured shape;

a top surface connected to the inner surface and the bone interface surface, wherein the inner surface, the bone interface surface, and the top surface form two legs having a generally horseshoe shape; and

at least two openings extending along a longitudinal axis from the top surface, the at least two openings each include a locking mechanism comprising a plurality of fins, the plurality of fins being disposed around an inner perimeter of each opening, the plurality of fins with respect to each opening being disposed within a plane, the plane of each opening having an orientation relative to the mating face, and wherein the first contoured shape having an arcuate contour that extends inwardly into a portion of the second surface in a direction generally toward the bone interface surface.

22. The augment device of claim 21, wherein each of the at least two openings has an orientation relative to the mating face.

23. An orthopedic device, comprising:

a first surface having a mating face configured to mate with an implant; and  
a second surface adjacent to the first surface and intersecting the first surface at an edge, the second surface comprising an opening extending along a central axis and through the second surface to an opposite surface, wherein the opening is configured to receive a fastener, said opening including a plurality of fins disposed in a plane that is not parallel to the mating face, and wherein the mating face is shaped such that a distance that the mating face is offset from the central axis in a direction perpendicular to the central axis varies as the mating face extends downwardly away from the edge;

wherein at least a portion of the first surface is formed from a porous material.

24. The orthopedic device of claim 23, wherein the opening is configured as a through hole and the opening comprises a first end in the second surface and a second end in a surface opposite the second surface.

25. The orthopedic device of claim 24, wherein the opening is configured to receive a fastener inserted into the first end in the second surface when the device is in a first orientation and is configured to receive a fastener inserted into the second end opposite the second surface when the device is in a second orientation.
26. The orthopedic device of claim 25, wherein the fins are disposed between the first and second ends of the opening.
27. The orthopedic device of claim 25, wherein the fins are configured to lock a fastener in a first locked configuration when the device is in the first orientation and are configured to lock a fastener in a second locked configuration when the device is in the second orientation.
28. The orthopedic device of claim 25, wherein the mating face is configured to mate with an implant when the device is in each of the first and second orientations.
29. The orthopedic device of claim 23, further comprising a bone interface surface configured to mate with a patient's bone or tissue.
30. The orthopedic device of claim 23, wherein the plane is arranged substantially perpendicular to the mating face.
31. The orthopedic device of claim 23, wherein the fins are configured to engage a fastener inserted along any one of a plurality of axes and lock the fastener in a plurality of locking configurations corresponding to the plurality of axes.
32. An augment device, comprising:
  - an inner surface with mating face, at least a portion of the inner surface comprising a porous material, the mating face having an arcuate shape across the mating face in at least two directions;
  - a bone interface surface opposite the mating face;
  - a top surface connected to the inner surface and the bone interface surface,

wherein the inner surface, the bone interface surface, and the top surface form two legs having a generally horseshoe shape; and

at least one opening extending from the top surface, the at least one opening including a locking mechanism comprising a plurality of fins.

33. The augment device of claim 32, wherein the mating face is configured to match the shape of an exterior surface of an orthopaedic implant.

34. The augment device of claim 32, wherein the orientation of the at least one opening is relative to the mating face.

35. The augment device of claim 32, wherein the mating face is configured to mate with an implant when the device is in each of the first and second orientations.

36. The augment device of claim 32, wherein at least one of the bone interface surface and the top surface comprise a porous material portion.

37. The augment device of claim 32, wherein the plane is arranged substantially perpendicular to the mating face.

38. The augment device of claim 32, wherein the plurality of fins is configured to engage a fastener inserted along any one of a plurality of axes and lock the fastener in a plurality of locking configurations corresponding to the plurality of axes.

39. The augment device of claim 32, wherein the at least one opening is configured as a through hole and the opening comprises a first end in the top surface and a second end in a surface opposite the top surface.

40. The augment device of claim 39, wherein the opening is configured to receive a fastener inserted into the first end in the top surface when the device is in a first orientation and is configured to receive a fastener inserted into the second end opposite the top surface when the device is in a second orientation.

41. The augment device of claim 39, wherein the plurality of fins is disposed between the first and second ends of the opening.

42. The augment device of claim 39, wherein the plurality of fins is configured to lock a fastener in a first locked configuration when the device is in the first orientation and is configured to lock a fastener in a second locked configuration when the device is in the second orientation.

43. An augment device, comprising:

an inner surface with a mating face, at least a portion of the inner surface comprising a porous material;

a bone interface surface opposite the mating face;

a top surface connected to the inner surface and the bone interface surface, wherein the inner surface, the bone interface surface, and the top surface form two legs having a generally horseshoe shape; and

at least two openings extending from the top surface, the at least two openings each include a locking mechanism comprising a plurality of fins, the plurality of fins are disposed around an inner perimeter of each opening, and the plurality of fins with respect to each opening is disposed within a plane, and the plane of each opening has an orientation relative that is not parallel to the mating face, and wherein each of the at least two openings is positioned approximately adjacent to both the mating face and the bone interface surface.

44. The augment device of claim 43, wherein each of the at least two openings has an orientation relative to the mating face.

45. An acetabular system comprising:

an implant including an exterior surface; and

an augment including:

a mating surface adapted and configured to contact the exterior surface of the implant during use;

a first surface intersecting the mating surface along a first edge;

a second surface intersecting the mating surface along a second edge; and

a plurality of openings extending from the first surface to the second surface, at least one of the openings including a plurality of fins extending inwardly from an inner surface of the opening, the plurality of fins being adapted and configured to

selectively secure a position of a fastener inserted therein along any one of a variety of angles for securing the augment to a patient's bone during use; wherein the plurality of fins are arranged and configured in a plane, the plane being non-parallel to the mating surface.

46. The system of claim 45, wherein the plane of the fins is substantially perpendicular to the mating face.

47. The system of claim 45, wherein the augment includes a generally horseshoe shape including a body portion and first and second legs extending from opposite ends of the body portion.

48. The system of claim 45, wherein the implant is selected from one of an acetabular shell or an acetabular cage.

49. The system of claim 45, wherein each of the plurality of openings includes a first end associated with the first surface of the augment and a second end associated with the second surface of the augment, the plurality of openings being adapted and configured to selectively receive a fastener inserted into either of the first end or the second end.

50. The system of claim 49, wherein the fastener is inserted into the first end when the augment is positioned in a first orientation relative to the implant, and the fastener is inserted into the second end when the augment is positioned in a second orientation.

51. The system of claim 50, wherein the mating face of the augment is configured to mate with the implant in each of the first and second orientations.

52. The system of claim 51, wherein the augment further comprises a bone contacting surface, the bone contacting surface configured to mate with the patient's bone or tissue in each of the first and second orientations.

53. The system of claim 45, wherein the plurality of fins and the opening are adapted and configured to enable longitudinal movement of a fastener within the opening.

54. The system of claim 45, wherein the opening includes a width, the width of the opening and a space between the plurality of fins being adapted and configured to allow for movement of the fastener so that an axis of the fastener is offset from the central axis of the opening. The system of claim 1, wherein the mating surface of the augment includes an arcuate, contoured shape and the exterior surface of the implant includes an outer curved surface.

55. The system of claim 54, wherein the augment further comprises a bone interface surface opposite the mating face, the bone interface surface having a second contoured shape that mates with a patient's bone or tissue, the arcuate, contoured shape being different than the second contoured shape.

56. The system of claim 55, wherein the bone interface surface is arranged and configured to be non-parallel to the plane of the plurality of fins.

57. The system of claim 45, wherein at least a portion of the mating face is formed from a porous material.

58. An orthopedic augment adapted and configured to contact with an exterior surface of an acetabular cage or system during use, the augment comprising:

a mating surface adapted and configured to contact the exterior surface of the acetabular cage or system;

a first surface intersecting the mating surface along a first edge;

a second surface intersecting the mating surface along a second edge; and

a plurality of openings extending from the first surface to the second surface, the openings including a plurality of fins extending inwardly from an inner surface of the opening, the plurality of fins being adapted and configured to selectively secure a position of a fastener inserted therein along any one of a variety of angles for securing the augment to a patient during use;

wherein the plurality of fins are arranged and configured in a plane, the plane being non-parallel to the mating surface.

59. The augment of claim 58, wherein the plane of the fins is substantially perpendicular to the mating face.

60. The augment of claim 58, wherein the augment includes a generally horseshoe shape including a body portion and first and second legs extending from opposite ends of the body portion.

61. The augment of claim 58, wherein each of the plurality of openings includes a first end associated with the first surface of the augment and a second end associated with the second surface of the augment, the plurality of openings being adapted and configured to selectively receive a fastener inserted into either of the first end or the second end.

62. The augment of claim 58, wherein the mating surface includes a first contoured shape and the augment further comprises a bone interface surface opposite the mating face, the bone interface surface having a second contoured shape that mates with a patient's bone or tissue, the first contoured shape being different than the second contoured shape.

63. The augment of claim 20, wherein the bone interface surface is arranged and configured to be non-parallel to the plane of the plurality of fins.

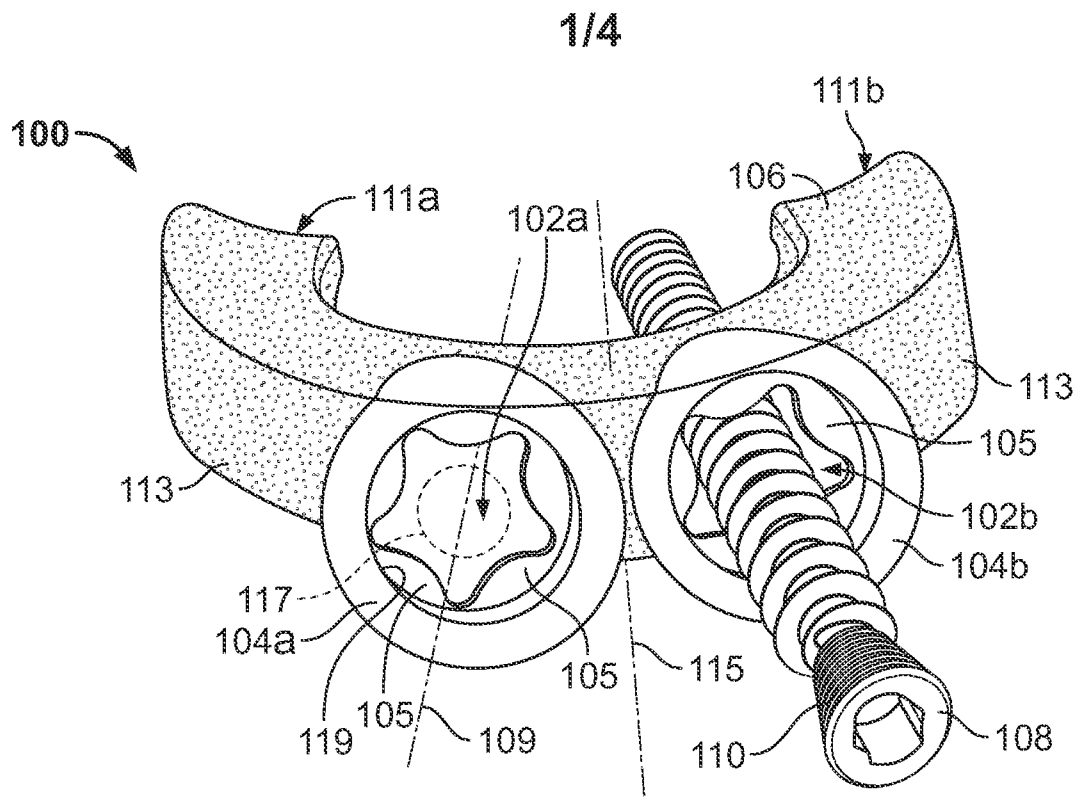

FIG. 1A

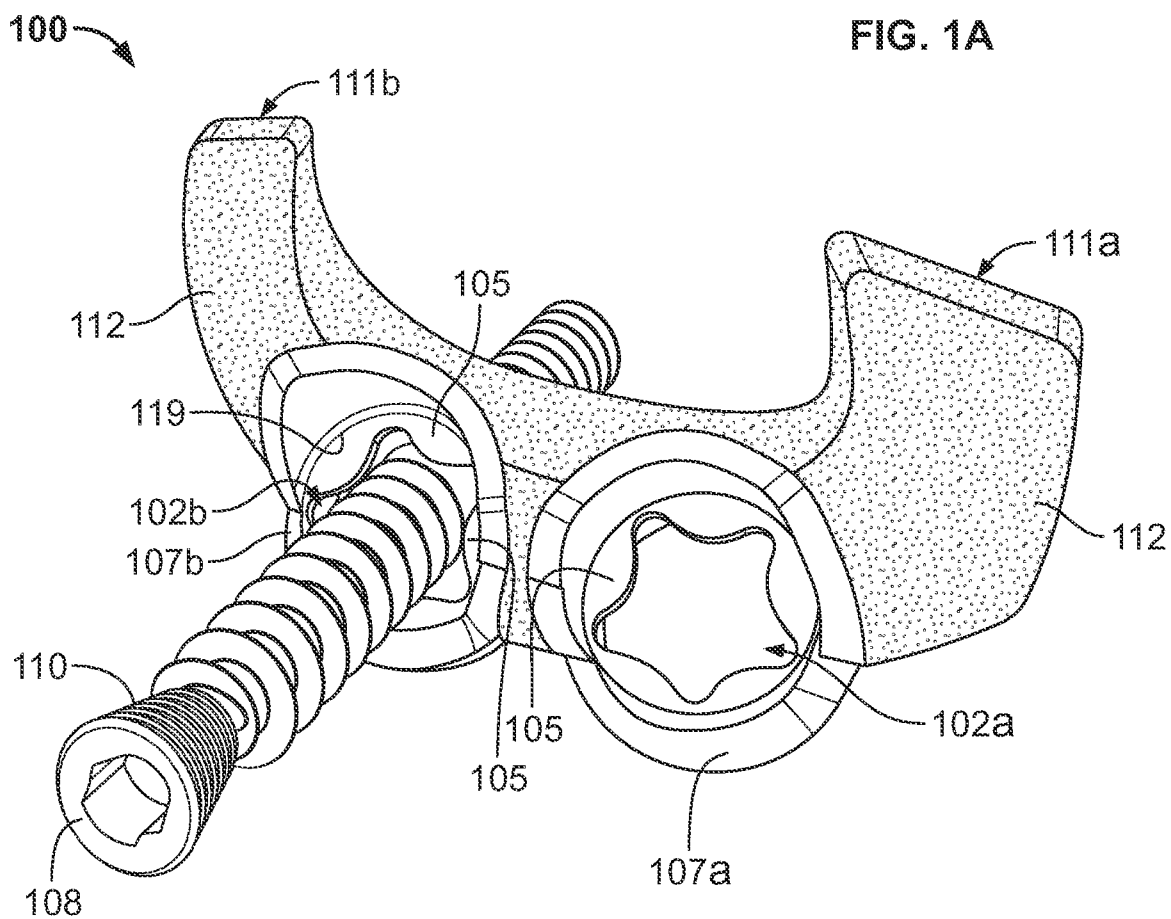
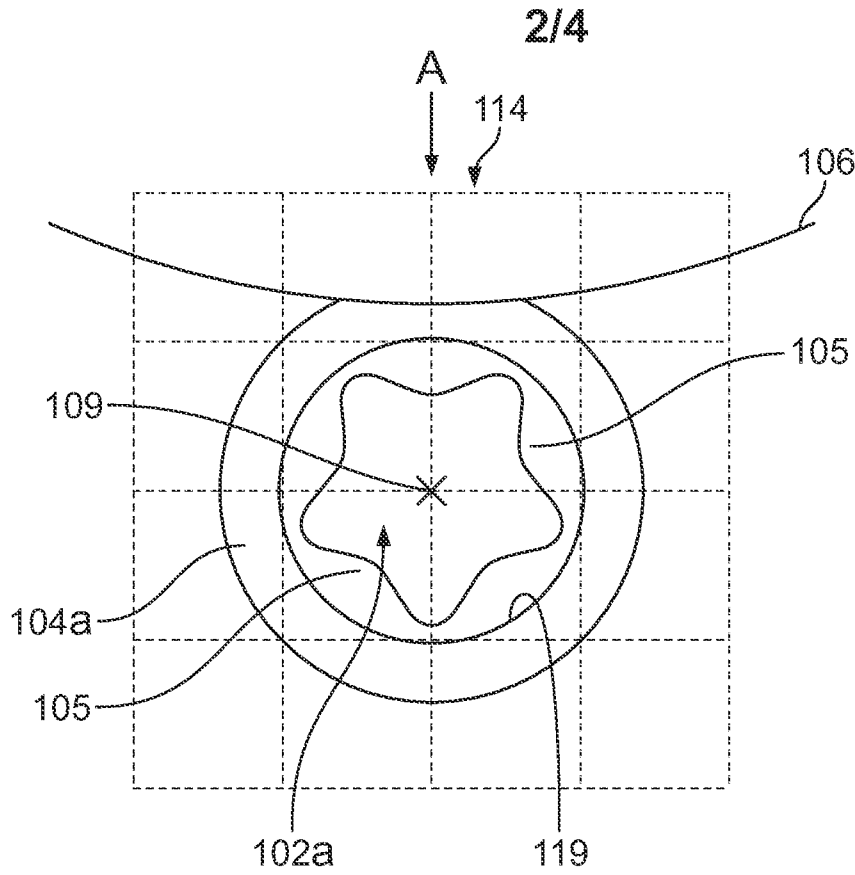
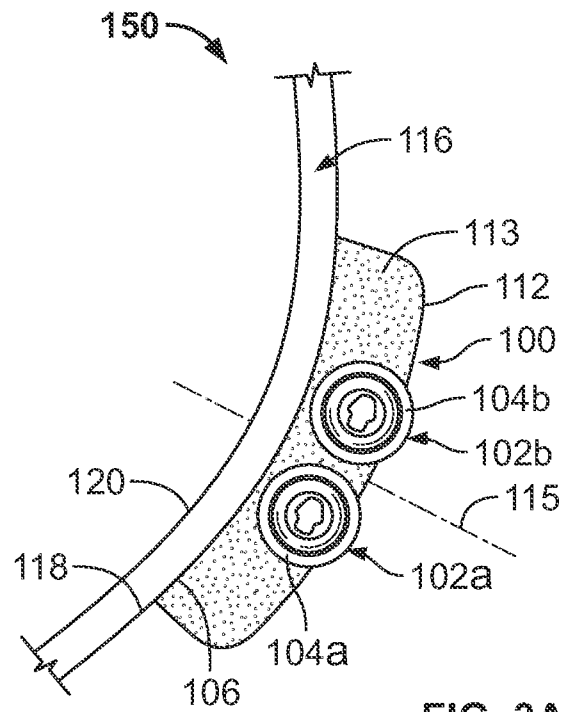

FIG. 1B

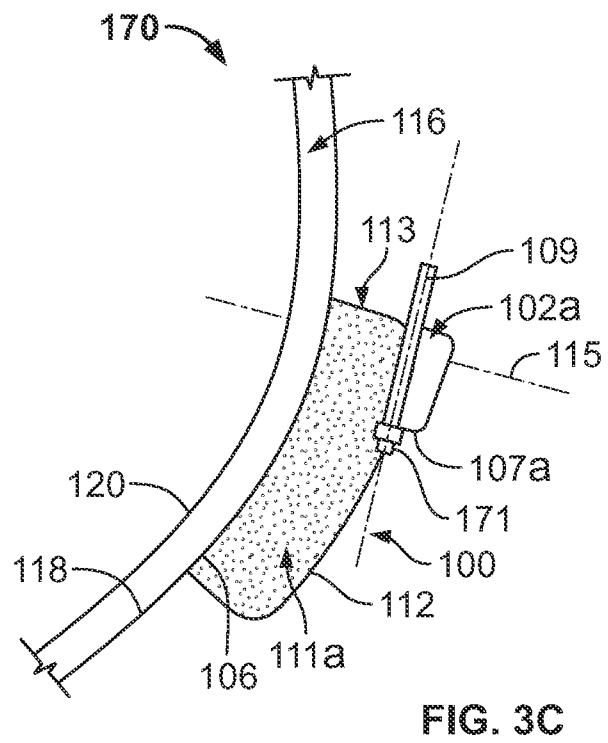
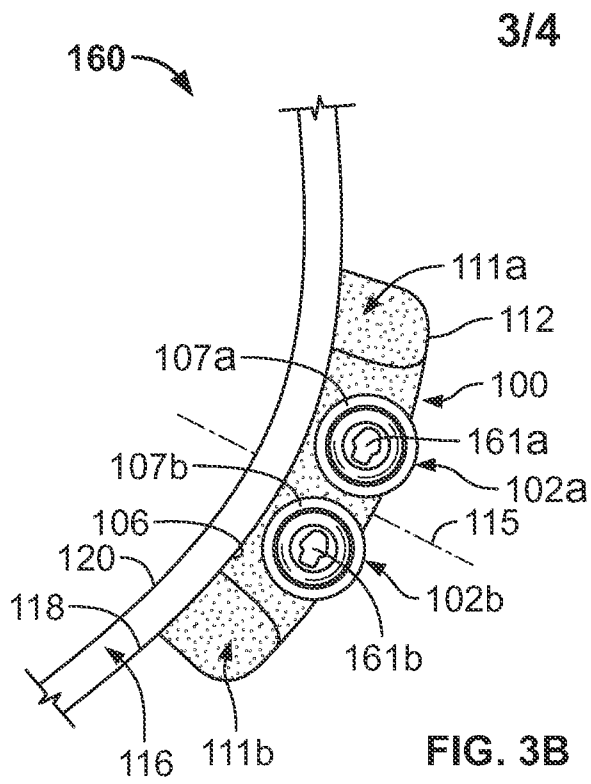



**FIG. 2**



**FIG. 3A**



4/4

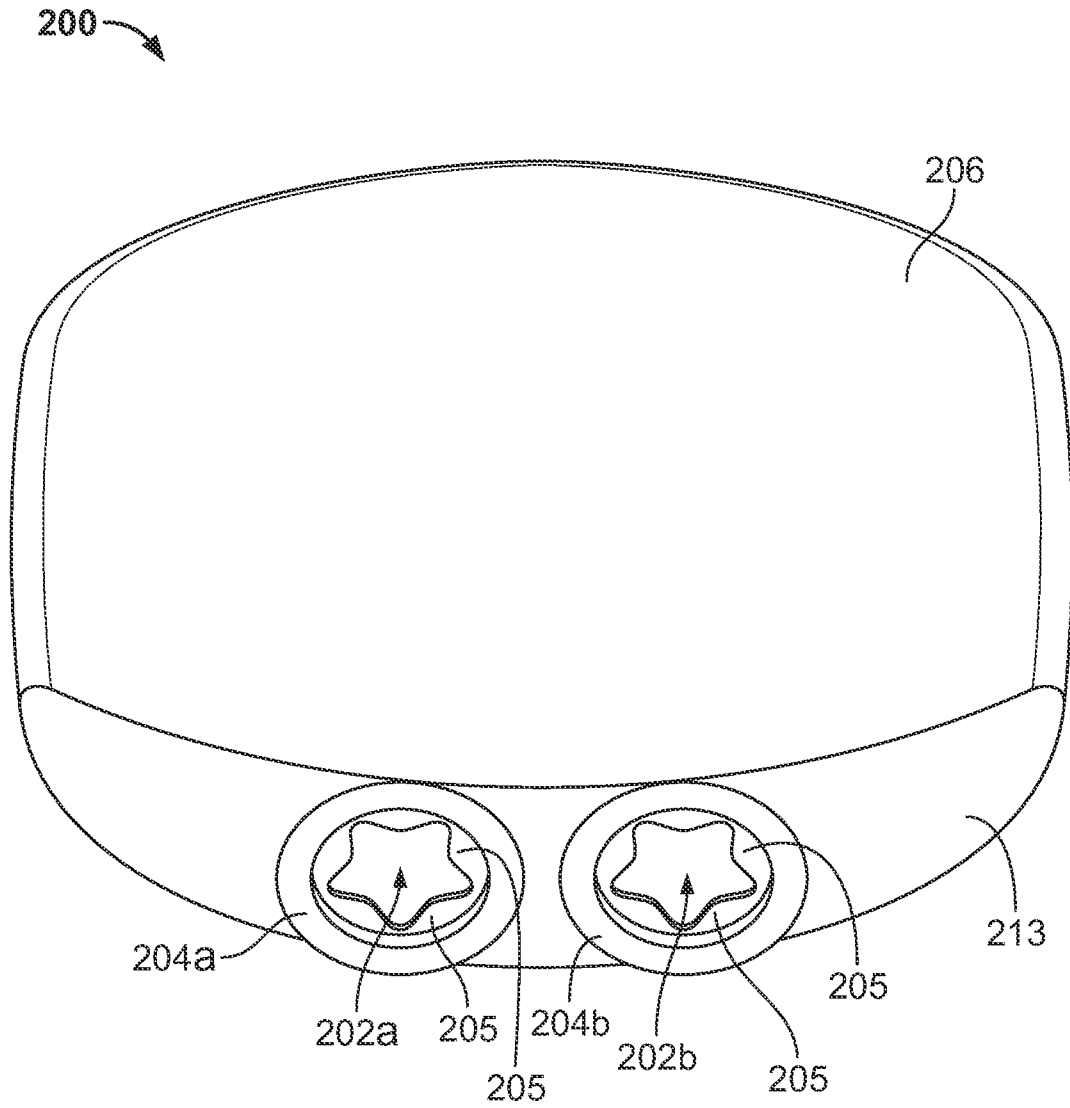

FIG. 4

