

Oct. 1, 1935.

H. S. FORSBERG

2,016,107

SAW HANDLE

Filed Jan. 3, 1935

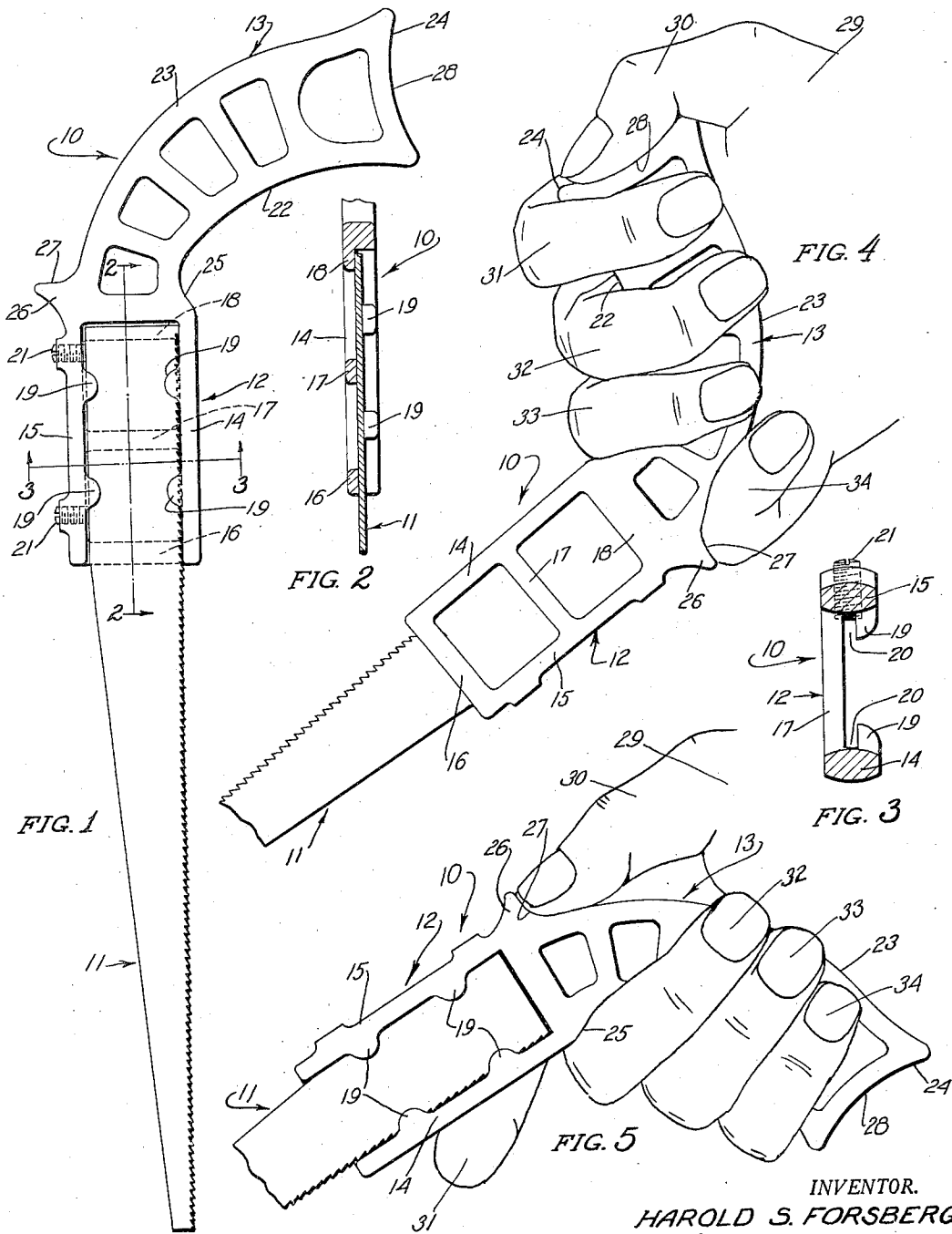

INVENTOR.  
HAROLD S. FORSBERG.  
BY *John M. Hawahan*  
ATTORNEY.

# UNITED STATES PATENT OFFICE

2,016,107

## SAW HANDLE

Harold S. Forsberg, Stratford, Conn.

Application January 3, 1935, Serial No. 229

2 Claims. (Cl. 145—108)

This invention relates to new and useful improvements in hand saws and has particular relation to the handles of such saws.

An object of the invention is to provide a saw handle so constructed and arranged as to enable a user to obtain a firm grip on the handle.

Another object is to provide a saw handle so constructed that a user may obtain an excellent grip on the handle enabling him to both push and pull the saw irrespective of whether the user is sawing downwardly or upwardly.

Other objects and advantages will become apparent from a consideration of the following detailed description taken in connection with the accompanying drawing wherein a satisfactory embodiment of the invention is shown. However, it will be understood that the invention is not limited to the details disclosed but includes all such variations and modifications as fall within the spirit of the invention and the scope of the appended claims.

In the drawing:

Fig. 1 is a side elevational view showing the improved handle in association with a saw;

Fig. 2 is a detail sectional view taken substantially along the line 2—2 of Fig. 1;

Fig. 3 is an enlarged detail sectional view taken substantially along the line 3—3 of Fig. 1;

Fig. 4 is an elevational view showing the manner of gripping the handle when sawing upwardly; and

Fig. 5 is a similar view showing the manner of gripping the handle when sawing downwardly.

Referring in detail to the drawing, the improved handle generally designated 10 is shown as comprising a portion of a keyhole or compass saw including a blade 11 having teeth along one of its edges. As shown, the handle 10 is of one piece construction comprising a casting including a blade attaching portion 12 and a grip portion 13. The portion 12 includes inner and outer bars 14 and 15 connected along one side as by straps 16, 17 and 18 and along their other edges the bars are provided with lugs 19 arranged in pairs opposite and extending toward one another. The butt end of the blade is inserted into the portion 12 between the bars 14 and 15 and between the straps along one edge of said bars and the lugs 19 at the other edges of the bars, the butt portion of the blade being actually received in the groove-like recesses 20 of Fig. 3. Short screws 21 are threadable through the bar 15 of the attaching portion and on tightening of said screw the saw blade will be rigidly but removably secured to the handles as will be understood.

The grip portion 13 has its inner and outer edges or wall members 22 and 23 constantly curving upwardly and forwardly from its distal or outer end or web 24 to its junction with the rear end of the attaching portion 12. At this junction the inner edge of the gripping portion is inwardly of the inner edge of the attaching portion whereby to provide a shoulder 25 for abutment by a finger of the user as will later more fully appear. Extending outwardly from the outer edge of the handle substantially at the junction of the attaching and gripping portions thereof, is a lug 26 the rear surface portion 27 of which is slightly rearwardly of the shoulder 25. The grip portion 13 may be made up in the web or grid form as shown best in Fig. 1, but in any case the outer end of such portion is relatively wide and is depressed or concaved as at 28. This depression or concavity forms a thumb rest as will later more fully appear.

Assuming that the saw is being used to saw downwardly as in Fig. 5 then the grip 13 may be held in the hand 29 with the thumb 30 against the rear surface of the lug 26, with the index finger 31 at the side of the attaching portion 12 and with the fingers 32, 33 and 34 extending about the inner edge 22 of the grip. One side of the finger 32 at about the second joint thereof will be against the shoulder 25 and the inner portion or palm of the hand will be against the outer edge 23 of the grip. The curvature of the inner and outer edges of the grip being constant upwardly and forwardly and the lug 26 and shoulder 25 being properly located the hand may be readily disposed to have the thumb and the index finger 32 press against the lug 26 and the shoulder 25 respectively. If desired, the index finger 31 might be doubled under the grip and then such finger and not the finger 32 would press against the shoulder 25. With the described construction it will be apparent that a firm grip may be obtained on the handle so as to push and pull the same to impart the necessary motion to the blade 11.

When the saw is to be used to saw upwardly it is not necessary to reverse the position of the blade 11 with respect to the handle since the entire assembly may be turned over as suggested in Fig. 4. In that figure the rear side of the little finger 34 is pressing against the rear surface of the lug 26 while the fingers 31, 32 and 33 are wrapped about the inner edge 22 of the grip with the finger 33 against the shoulder 25. The thumb is resting in the concavity or depression 28 in the outer end of the handle and the palm of the hand

is against the outer edge 23 of the grip portion. With this grip it will be apparent that the handle may be pushed and pulled to impart the necessary motion to the blade 11 and that with the handle  
5 construction disclosed, when gripped as in Fig. 4, the saw may be used successfully to saw upwardly without changing the relationship between the blade and handle. Of course, on loosening of the screws 21 the blade may be removed and then re-  
10 placed in reverse position from that shown after which the screws would be tightened to secure the blade to the handle.

Having thus set forth the nature of my invention, what I claim is:

15 1. A saw handle comprising a cast metal body having a blade attaching portion and a gripping portion, said gripping portion having a rear arcuate wall member provided with a convex edge and a front arcuate wall member provided with a  
20 concave edge, said wall members extending rearwardly and downwardly from said blade attaching portion, spaced web members disposed between and connecting said wall members, said concave edge terminating at and higher than the  
25 lower edge of the attaching portion to provide a shoulder, a lug extending outwardly from the rear wall member substantially opposite to said

shoulder, whereby the handle may be held in either normal or inverted position with said gripping portion in the palm of the hand disposed between fingers engaged respectively with said  
5 shoulder and said lug.

2. A saw handle comprising a cast metal body having a blade attaching portion and a gripping portion, said gripping portion having a rear arcuate wall member provided with a convex edge and a front arcuate wall member provided with a  
10 concave edge, said wall members extending rearwardly and downwardly from said blade attaching portion, spaced web members disposed between and connecting said wall members, said concave edge terminating at and higher than the  
15 lower edge of the attaching portion to provide a shoulder, a lug extending outwardly from the rear wall member substantially opposite to said shoulder, whereby the handle may be held in  
20 either normal or inverted position with said gripping portion in the palm of the hand disposed between fingers engaged respectively with said shoulder and said lug, one of said web members connecting the distal ends of said wall members  
25 and being concave for engagement by a finger when the handle is inverted.

HAROLD S. FORSBERG.