

**(12) STANDARD PATENT**  
**(19) AUSTRALIAN PATENT OFFICE**

(11) Application No. **AU 2004266311 B2**

(54) Title  
**RNA interference mediated inhibition of gene expression using chemically modified short interfering nucleic acid (siNA)**

(51) International Patent Classification(s)  
**C12N 15/11** (2006.01)                      **C07H 21/02** (2006.01)  
**A01N 43/04** (2006.01)                      **C07H 21/04** (2006.01)  
**A61K 48/00** (2006.01)                      **C12P 19/34** (2006.01)

(21) Application No: **2004266311**                      (22) Date of Filing: **2004.05.24**

(87) WIPO No: **WO05/019453**

(30) Priority Data

(31) Number	(32) Date	(33) Country
<b>10/444,853</b>	<b>2003.05.23</b>	<b>US</b>
<b>10/757,803</b>	<b>2004.01.14</b>	<b>US</b>
<b>10/693,059</b>	<b>2003.10.23</b>	<b>US</b>
<b>10/720,448</b>	<b>2003.11.24</b>	<b>US</b>
<b>10/780,447</b>	<b>2004.02.13</b>	<b>US</b>
<b>60/543,480</b>	<b>2004.02.10</b>	<b>US</b>
<b>10/727,780</b>	<b>2003.12.03</b>	<b>US</b>
<b>10/652,791</b>	<b>2003.08.29</b>	<b>US</b>
<b>10/826,966</b>	<b>2004.04.16</b>	<b>US</b>

(43) Publication Date: **2005.03.03**

(44) Accepted Journal Date: **2009.07.23**

(71) Applicant(s)  
**Sirna Therapeutics, Inc.**

(72) Inventor(s)  
**Morrissey, David;Jadhav, Vasant;Mcswiggen, James;Zinnen, Shawn;Vaish, Narendra**

(74) Agent / Attorney  
**Spruson & Ferguson, Level 35 St Martins Tower 31 Market Street, Sydney, NSW, 2000**

(56) Related Art  
**Leirdal & Sioud, 2002, Biochemcial and Biophysical Research Communications, Vol 295, pages 744-748**

(19) World Intellectual Property  
Organization  
International Bureau



(43) International Publication Date  
3 March 2005 (03.03.2005)

PCT

(10) International Publication Number  
WO 2005/019453 A3

(51) International Patent Classification<sup>7</sup>: C12N 15/11,  
C12P 19/34, C07H 21/02, 21/04, A01N 43/04

[IN/US]; 1313 Williams Street, #503, Denver, CO 80218  
(US).

(21) International Application Number:  
PCT/US2004/016390

(74) Agent: GREENFIELD, Michael, S.; McDonnell  
Boehnen Hulbert and Berghoff, 300 South Wacker Drive,  
Chicago, IL 60606 (US).

(22) International Filing Date: 24 May 2004 (24.05.2004)

(81) Designated States (unless otherwise indicated, for every  
kind of national protection available): AE, AG, AL, AM,  
AT, AU, AZ, BA, BB, BG, BR, BW, BY, BZ, CA, CH, CN,  
CO, CR, CU, CZ, DE, DK, DM, DZ, EC, EE, EG, ES, FI,  
GB, GD, GE, GH, GM, HR, HU, ID, IL, IN, IS, JP, KE,  
KG, KP, KR, KZ, LC, LK, LR, LS, LT, LU, LV, MA, MD,  
MG, MK, MN, MW, MX, MZ, NA, NI, NO, NZ, OM, PG,  
PH, PL, PT, RO, RU, SC, SD, SE, SG, SK, SL, SY, TJ, TM,  
TN, TR, TT, TZ, UA, UG, US, UZ, VC, VN, YU, ZA, ZM,  
ZW.

(25) Filing Language: English

(26) Publication Language: English

(30) Priority Data:  
10/444,853 23 May 2003 (23.05.2003) US  
10/652,791 29 August 2003 (29.08.2003) US  
10/693,059 23 October 2003 (23.10.2003) US  
10/720,448 24 November 2003 (24.11.2003) US  
10/727,780 3 December 2003 (03.12.2003) US  
10/757,803 14 January 2004 (14.01.2004) US  
60/543,480 10 February 2004 (10.02.2004) US  
10/780,447 13 February 2004 (13.02.2004) US  
10/826,966 16 April 2004 (16.04.2004) US

(84) Designated States (unless otherwise indicated, for every  
kind of regional protection available): ARIPO (BW, GH,  
GM, KE, LS, MW, MZ, NA, SD, SL, SZ, TZ, UG, ZM,  
ZW), Eurasian (AM, AZ, BY, KG, KZ, MD, RU, TJ, TM),  
European (AT, BE, BG, CH, CY, CZ, DE, DK, EE, ES, FI,  
FR, GB, GR, HU, IE, IT, LU, MC, NL, PL, PT, RO, SE, SI,  
SK, TR), OAPI (BF, BJ, CF, CG, CI, CM, GA, GN, GQ,  
GW, ML, MR, NE, SN, TD, TG).

(71) Applicant (for all designated States except US): SIRNA  
THERAPEUTICS, INC. [US/US]; 2950 Wilderness  
Place, Boulder, CO 80301 (US).

Published:  
— with international search report

(72) Inventors; and  
(75) Inventors/Applicants (for US only): MCSWIGGEN,  
James [US/US]; 4866 Franklin Drive, Boulder, CO 80301  
(US). MORRISSEY, David [US/US]; 4769 Tangle-  
wood Trail, Boulder, CO 80301 (US). ZINNEN, Shawn  
[US/US]; 2378 Birch Street, Denver, CO 80207 (US).  
JADHAV, Vasant [IN/US]; 1951 Grandview Avenue,  
Apt. #A4-B, Boulder, CO 80302 (US). VAISH, Narendra

(88) Date of publication of the international search report:  
23 June 2005

For two-letter codes and other abbreviations, refer to the "Guidance Notes on Codes and Abbreviations" appearing at the beginning of each regular issue of the PCT Gazette.



WO 2005/019453 A3

(54) Title: RNA INTERFERENCE MEDIATED INHIBITION OF GENE EXPRESSION USING CHEMICALLY MODIFIED SHORT INTERFERING NUCLEIC ACID (siNA)

(57) Abstract: The present invention concerns methods and reagents useful in modulating gene expression in a variety of applications, including use in therapeutic, cosmetic, cosmeceutical, prophylactic, diagnostic, target validation, and genomic discovery applications. Specifically, the invention relates to synthetic chemically modified small nucleic acid molecules, such as short interfering nucleic acid (siNA), short interfering RNA (siRNA), double-stranded RNA (dsRNA), micro-RNA (miRNA), and short hairpin RNA (shRNA) molecules capable of mediating RNA interference (RNAi) against target nucleic acid sequences. The small nucleic acid molecules are useful in the treatment of any disease (e.g., cancer, proliferative, inflammatory, metabolic, autoimmune, neurologic, ocular diseases), condition, trait (e.g., hair growth and removal), genotype or phenotype that responds to modulation of gene expression or activity in a cell, tissue, or organism. Such small nucleic acid molecules can be administered systemically, locally, or topically.

**RNA INTERFERENCE MEDIATED INHIBITION OF GENE EXPRESSION  
USING CHEMICALLY MODIFIED SHORT INTERFERING NUCLEIC ACID  
(siNA)**

This application is a continuation-in-part of U.S. Patent Application No. 10/826,966,  
5 filed April 16, 2004, which is a continuation-in-part of U.S. Patent Application No.  
10/757,803, filed January 14, 2004, which is a continuation-in-part of U.S. Patent  
Application No. 10/720,448, filed November 24, 2003, which is a continuation-in-part of  
U.S. Patent Application No. 10/693,059, filed October 23, 2003, which is a  
continuation-in-part of U.S. Patent Application No. 10/444,853, filed May 23, 2003 and a  
10 continuation-in-part of 10/652,791, filed August 29, 2003, which is a continuation of  
10/422,704, filed April 24, 2003, which is a continuation of U.S. Patent Application No.  
10/417,012, filed April 16, 2003. This application is also a continuation-in-part of  
International Patent Application No. PCT/US03/05346, filed February 20, 2003, and a  
continuation-in-part of International Patent Application No. PCT/US03/05028, filed  
15 February 20, 2003, both of which claim the benefit of U.S. Provisional Application No.  
60/358,580 filed February 20, 2002, U.S. Provisional Application No. 60/363,124 filed  
March 11, 2002, U.S. Provisional Application No. 60/386,782 filed June 6, 2002, U.S.  
Provisional Application No. 60/406,784 filed August 29, 2002, U.S. Provisional  
Application No. 60/408,378 filed September 5, 2002, U.S. Provisional Application No.  
20 60/409,293 filed September 9, 2002, and U.S. Provisional Application No. 60/440,129  
filed January 15, 2003. This application is also a continuation-in-part of US Patent  
Application No. 10/427,160, filed April 30, 2003 and International Patent Application No.  
PCT/US02/15876 filed May 17, 2002. This application is also a continuation-in-part of  
U.S. Patent Application No. 10/727,780 filed December 3, 2003. This application also  
25 claims the benefit of U.S. Provisional Application No. 60/543,480 filed February 10, 2004.  
The instant application claims the benefit of all the listed applications, which are hereby  
incorporated by reference in their entireties, including the drawings.

Field Of The Invention

The present invention comprises methods and reagents useful in modulating gene  
30 expression in a variety of applications, including use in therapeutic, cosmetic,  
cosmeceutical, prophylactic, diagnostic, target validation, and genomic discovery

applications. Specifically, the invention comprises synthetic small nucleic acid molecules, such as short interfering nucleic acid (siNA), short interfering RNA (siRNA), double-stranded RNA (dsRNA), micro-RNA (miRNA), and short hairpin RNA (shRNA) molecules capable of mediating RNA interference (RNAi).

5

#### Background Of The Invention

The following is a discussion of relevant art pertaining to RNAi. The discussion is provided only for understanding of the invention that follows. The summary is not an admission that any of the work described below is prior art to the claimed invention. Applicant demonstrates herein that chemically modified short interfering nucleic acids  
10 possess the same capacity to mediate RNAi as do siRNA molecules and are expected to possess improved stability and activity in vivo; therefore, this discussion is not meant to be limiting only to siRNA and can be applied to siNA as a whole.

RNA interference refers to the process of sequence-specific post-transcriptional gene silencing in animals mediated by short interfering RNAs (siRNAs) (Zamore *et al.*, 2000,  
15 *Cell*, 101, 25-33; Fire *et al.*, 1998, *Nature*, 391, 806; Hamilton *et al.*, 1999, *Science*, 286, 950-951; Lin *et al.*, 1999, *Nature*, 402, 128-129; and Strauss, 1999, *Science*, 286, 886). The corresponding process in plants (Heifetz *et al.*, International PCT Publication No. WO 99/61631) is commonly referred to as post-transcriptional gene silencing or RNA silencing and is also referred to as quelling in fungi. The process of post-transcriptional gene  
20 silencing is thought to be an evolutionarily-conserved cellular defense mechanism used to prevent the expression of foreign genes and is commonly shared by diverse flora and phyla (Fire *et al.*, 1999, *Trends Genet.*, 15, 358). Such protection from foreign gene expression may have evolved in response to the production of double-stranded RNAs (dsRNAs) derived from viral infection or from the random integration of transposon elements into a  
25 host genome via a cellular response that specifically destroys homologous single-stranded RNA or viral genomic RNA. The presence of dsRNA in cells triggers the RNAi response through a mechanism that has yet to be fully characterized. This mechanism appears to be different from other known mechanisms involving double stranded RNA-specific ribonucleases, such as the interferon response that results from dsRNA-mediated activation  
30 of protein kinase PKR and 2',5'-oligoadenylate synthetase resulting in non-specific cleavage of mRNA by ribonuclease L (see for example US Patent Nos. 6,107,094;



5,898,031; Clemens *et al.*, 1997, *J. Interferon & Cytokine Res.*, 17, 503-524; Adah *et al.*, 2001, *Curr. Med. Chem.*, 8, 1189).

The presence of long dsRNAs in cells stimulates the activity of a ribonuclease III enzyme referred to as dicer (Bass, 2000, *Cell*, 101, 235; Zamore *et al.*, 2000, *Cell*, 101, 25-33; Hammond *et al.*, 2000, *Nature*, 404, 293). Dicer is involved in the processing of the dsRNA into short pieces of dsRNA known as short interfering RNAs (siRNAs) (Zamore *et al.*, 2000, *Cell*, 101, 25-33; Bass, 2000, *Cell*, 101, 235; Bernstein *et al.*, 2001, *Nature*, 409, 363). Short interfering RNAs derived from dicer activity are typically about 21 to about 23 nucleotides in length and comprise about 19 base pair duplexes (Zamore *et al.*, 2000, *Cell*, 101, 25-33; Elbashir *et al.*, 2001, *Genes Dev.*, 15, 188). Dicer has also been implicated in the excision of 21- and 22-nucleotide small temporal RNAs (stRNAs) from precursor RNA of conserved structure that are implicated in translational control (Hutvagner *et al.*, 2001, *Science*, 293, 834). The RNAi response also features an endonuclease complex, commonly referred to as an RNA-induced silencing complex (RISC), which mediates cleavage of single-stranded RNA having sequence complementary to the antisense strand of the siRNA duplex. Cleavage of the target RNA takes place in the middle of the region complementary to the antisense strand of the siRNA duplex (Elbashir *et al.*, 2001, *Genes Dev.*, 15, 188).

RNAi has been studied in a variety of systems. Fire *et al.*, 1998, *Nature*, 391, 806, were the first to observe RNAi in *C. elegans*. Bahramian and Zarbl, 1999, *Molecular and Cellular Biology*, 19, 274-283 and Wianny and Goetz, 1999, *Nature Cell Biol.*, 2, 70, describe RNAi mediated by dsRNA in mammalian systems. Hammond *et al.*, 2000, *Nature*, 404, 293, describe RNAi in *Drosophila* cells transfected with dsRNA. Elbashir *et al.*, 2001, *Nature*, 411, 494 and Tuschl *et al.*, International PCT Publication No. WO 01/75164, describe RNAi induced by introduction of duplexes of synthetic 21-nucleotide RNAs in cultured mammalian cells including human embryonic kidney and HeLa cells. Recent work in *Drosophila* embryonic lysates (Elbashir *et al.*, 2001, *EMBO J.*, 20, 6877 and Tuschl *et al.*, International PCT Publication No. WO 01/75164) has revealed certain requirements for siRNA length, structure, chemical composition, and sequence that are essential to mediate efficient RNAi activity. These studies have shown that 21-nucleotide siRNA duplexes are most active when containing 3'-terminal dinucleotide overhangs. Furthermore, complete substitution of one or both siRNA strands with 2'-deoxy (2'-H) or 2'-O-methyl nucleotides abolishes RNAi activity, whereas substitution of the 3'-terminal

siRNA overhang nucleotides with 2'-deoxy nucleotides (2'-H) was shown to be tolerated. Single mismatch sequences in the center of the siRNA duplex were also shown to abolish RNAi activity. In addition, these studies also indicate that the position of the cleavage site in the target RNA is defined by the 5'-end of the siRNA guide sequence rather than the  
5 3'-end of the guide sequence (Elbashir *et al.*, 2001, *EMBO J.*, 20, 6877). Other studies have indicated that a 5'-phosphate on the target-complementary strand of a siRNA duplex is required for siRNA activity and that ATP is utilized to maintain the 5'-phosphate moiety on the siRNA (Nykanen *et al.*, 2001, *Cell*, 107, 309).

Studies have shown that replacing the 3'-terminal nucleotide overhanging segments  
10 of a 21-mer siRNA duplex having two-nucleotide 3'-overhangs with deoxyribonucleotides does not have an adverse effect on RNAi activity. Replacing up to four nucleotides on each end of the siRNA with deoxyribonucleotides has been reported to be well tolerated, whereas complete substitution with deoxyribonucleotides results in no RNAi activity (Elbashir *et al.*, 2001, *EMBO J.*, 20, 6877 and Tuschl *et al.*, International PCT Publication  
15 No. WO 01/75164). In addition, Elbashir *et al.*, *supra*, also report that substitution of siRNA with 2'-O-methyl nucleotides completely abolishes RNAi activity. Li *et al.*, International PCT Publication No. WO 00/44914, and Beach *et al.*, International PCT Publication No. WO 01/68836 preliminarily suggest that siRNA may include modifications to either the phosphate-sugar backbone or the nucleoside to include at least  
20 one of a nitrogen or sulfur heteroatom, however, neither application postulates to what extent such modifications would be tolerated in siRNA molecules, nor provides any further guidance or examples of such modified siRNA. Kreutzer *et al.*, Canadian Patent Application No. 2,359,180, also describe certain chemical modifications for use in dsRNA constructs in order to counteract activation of double-stranded RNA-dependent protein  
25 kinase PKR, specifically 2'-amino or 2'-O-methyl nucleotides, and nucleotides containing a 2'-O or 4'-C methylene bridge. However, Kreutzer *et al.* similarly fails to provide examples or guidance as to what extent these modifications would be tolerated in dsRNA molecules.

Parrish *et al.*, 2000, *Molecular Cell*, 6, 1077-1087, tested certain chemical modifications targeting the *unc-22* gene in *C. elegans* using long (>25 nt) siRNA  
30 transcripts. The authors describe the introduction of thiophosphate residues into these siRNA transcripts by incorporating thiophosphate nucleotide analogs with T7 and T3 RNA polymerase and observed that RNAs with two phosphorothioate modified bases also had

substantial decreases in effectiveness as RNAi. Further, Parrish *et al.* reported that phosphorothioate modification of more than two residues greatly destabilized the RNAs *in vitro* such that interference activities could not be assayed. *Id.* at 1081. The authors also tested certain modifications at the 2'-position of the nucleotide sugar in the long siRNA transcripts and found that substituting deoxynucleotides for ribonucleotides produced a substantial decrease in interference activity, especially in the case of Uridine to Thymidine and/or Cytidine to deoxy-Cytidine substitutions. *Id.* In addition, the authors tested certain base modifications, including substituting, in sense and antisense strands of the siRNA, 4-thiouracil, 5-bromouracil, 5-iodouracil, and 3-(aminoallyl)uracil for uracil, and inosine for guanosine. Whereas 4-thiouracil and 5-bromouracil substitution appeared to be tolerated, Parrish reported that inosine produced a substantial decrease in interference activity when incorporated in either strand. Parrish also reported that incorporation of 5-iodouracil and 3-(aminoallyl)uracil in the antisense strand resulted in a substantial decrease in RNAi activity as well.

The use of longer dsRNA has been described. For example, Beach *et al.*, International PCT Publication No. WO 01/68836, describes specific methods for attenuating gene expression using endogenously-derived dsRNA. Tuschl *et al.*, International PCT Publication No. WO 01/75164, describe a *Drosophila in vitro* RNAi system and the use of specific siRNA molecules for certain functional genomic and certain therapeutic applications; although Tuschl, 2001, *Chem. Biochem.*, 2, 239-245, doubts that RNAi can be used to cure genetic diseases or viral infection due to the danger of activating interferon response. Li *et al.*, International PCT Publication No. WO 00/44914, describe the use of specific long (141 bp-488 bp) enzymatically synthesized or vector expressed dsRNAs for attenuating the expression of certain target genes. Zernicka-Goetz *et al.*, International PCT Publication No. WO 01/36646, describe certain methods for inhibiting the expression of particular genes in mammalian cells using certain long (550 bp-714 bp), enzymatically synthesized or vector expressed dsRNA molecules. Fire *et al.*, International PCT Publication No. WO 99/32619, describe particular methods for introducing certain long dsRNA molecules into cells for use in inhibiting gene expression in nematodes. Plaetinck *et al.*, International PCT Publication No. WO 00/01846, describe certain methods for identifying specific genes responsible for conferring a particular phenotype in a cell using specific long dsRNA molecules. Mello *et al.*, International PCT Publication No. WO

01/29058, describe the identification of specific genes involved in dsRNA-mediated RNAi. Pachuck *et al.*, International PCT Publication No. WO 00/63364, describe certain long (at least 200 nucleotide) dsRNA constructs. Deschamps Depaillette *et al.*, International PCT Publication No. WO 99/07409, describe specific compositions consisting of particular  
5 dsRNA molecules combined with certain anti-viral agents. Waterhouse *et al.*, International PCT Publication No. 99/53050 and 1998, *PNAS*, 95, 13959-13964, describe certain methods for decreasing the phenotypic expression of a nucleic acid in plant cells using certain dsRNAs. Driscoll *et al.*, International PCT Publication No. WO 01/49844, describe specific DNA expression constructs for use in facilitating gene silencing in targeted  
10 organisms.

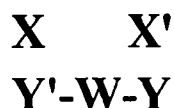
Others have reported on various RNAi and gene-silencing systems. For example, Parrish *et al.*, 2000, *Molecular Cell*, 6, 1077-1087, describe specific chemically-modified dsRNA constructs targeting the *unc-22* gene of *C. elegans*. Grossniklaus, International PCT Publication No. WO 01/38551, describes certain methods for regulating polycomb  
15 gene expression in plants using certain dsRNAs. Churikov *et al.*, International PCT Publication No. WO 01/42443, describe certain methods for modifying genetic characteristics of an organism using certain dsRNAs. Cogoni *et al.*, International PCT Publication No. WO 01/53475, describe certain methods for isolating a *Neurospora* silencing gene and uses thereof. Reed *et al.*, International PCT Publication No. WO  
20 01/68836, describe certain methods for gene silencing in plants. Honer *et al.*, International PCT Publication No. WO 01/70944, describe certain methods of drug screening using transgenic nematodes as Parkinson's Disease models using certain dsRNAs. Deak *et al.*, International PCT Publication No. WO 01/72774, describe certain *Drosophila*-derived gene products that may be related to RNAi in *Drosophila*. Arndt *et al.*, International PCT  
25 Publication No. WO 01/92513 describe certain methods for mediating gene suppression by using factors that enhance RNAi. Tuschl *et al.*, International PCT Publication No. WO 02/44321, describe certain synthetic siRNA constructs. Pachuk *et al.*, International PCT Publication No. WO 00/63364, and Satishchandran *et al.*, International PCT Publication No. WO 01/04313, describe certain methods and compositions for inhibiting the function  
30 of certain polynucleotide sequences using certain long (over 250 bp), vector expressed dsRNAs. Echeverri *et al.*, International PCT Publication No. WO 02/38805, describe certain *C. elegans* genes identified via RNAi. Kreutzer *et al.*, International PCT

Publication Nos. WO 02/055692, WO 02/055693, and EP 1144623 B1 describe certain methods for inhibiting gene expression using dsRNA. Graham *et al.*, International PCT Publication Nos. WO 99/49029 and WO 01/70949, and AU 4037501 describe certain vector expressed siRNA molecules. Fire *et al.*, US 6,506,559, describe certain methods for  
5 inhibiting gene expression in vitro using certain long dsRNA (299 bp-1033 bp) constructs that mediate RNAi. Martinez *et al.*, 2002, *Cell*, 110, 563-574, describe certain single stranded siRNA constructs, including certain 5'-phosphorylated single stranded siRNAs that mediate RNA interference in Hela cells. Harborth *et al.*, 2003, *Antisense & Nucleic Acid Drug Development*, 13, 83-105, describe certain chemically and structurally modified  
10 siRNA molecules. Chiu and Rana, 2003, *RNA*, 9, 1034-1048, describe certain chemically and structurally modified siRNA molecules. Woolf *et al.*, International PCT Publication Nos. WO 03/064626 and WO 03/064625 describe certain chemically modified dsRNA constructs.

#### SUMMARY OF THE INVENTION

15 This invention comprises compounds, compositions, and methods useful for modulating RNA function and/or gene expression in a cell. Specifically, the instant invention features synthetic small nucleic acid molecules, such as short interfering nucleic acid (siNA), short interfering RNA (siRNA), double-stranded RNA (dsRNA), micro-RNA (miRNA), and short hairpin RNA (shRNA) molecules capable of modulating gene  
20 expression in cells by RNA inference (RNAi). The siNA molecules of the invention can be chemically modified. The use of chemically modified siNA can improve various properties of native siRNA molecules through increased resistance to nuclease degradation *in vivo* and/or improved cellular uptake. The chemically modified siNA molecules of the instant invention provide useful reagents and methods for a variety of therapeutic, cosmetic,  
25 cosmeceutical, prophylactic, diagnostic, agricultural, target validation, genomic discovery, genetic engineering and pharmacogenomic applications.

According to an aspect of the invention, there is provided a multifunctional siNA molecule comprising a structure having Formula MF-III:



wherein

- 5 (a) each X, X', Y, and Y' is independently an oligonucleotide of length between 15 nucleotides and 50 nucleotides;
- (b) X comprises nucleotide sequence that is complementary to nucleotide sequence present in region Y';
- 10 (c) X' comprises nucleotide sequence that is complementary to nucleotide sequence present in region Y;
- (d) each X and X' is independently of length sufficient to stably interact with a first and a second target nucleic acid sequence, respectively, or a portion thereof;
- 15 (e) W represents a nucleotide or non-nucleotide linker that connects sequences Y' and Y; and
- (f) said multifunctional siNA directs cleavage of the first and second target sequence via RNA interference.

Pharmaceutical compositions comprising the multifunctional siNA molecule defined above, in an acceptable carrier or diluent, are also provided.

20 In one embodiment, the invention features compounds, compositions, and methods useful for modulating the expression of genes associated with the maintenance or development of a disease, condition, or trait in a cell, organism, or subject, for example genes and variants thereof, including polymorphic variants such as single nucleotide polymorphism (SNP) variants associated with one or more diseases, conditions, or traits

using short interfering nucleic acid (siNA) molecules. This invention also relates to compounds, compositions, and methods useful for modulating the expression and activity of genes associated with the maintenance or development of a disease, condition, or trait in a cell, organism, or subject by RNA interference (RNAi) using small nucleic acid  
5 molecules. In particular, the instant invention features small nucleic acid molecules, such as short interfering nucleic acid (siNA), short interfering RNA (siRNA), double-stranded RNA (dsRNA), micro-RNA (miRNA), and short hairpin RNA (shRNA) molecules and methods used to modulate the expression of genes and/or gene alleles associated with the development or maintenance of a disease, condition, or trait in a cell, organism, or subject.

10 In a non-limiting example, the introduction of chemically modified nucleotides into nucleic acid molecules provides a powerful tool in overcoming potential limitations of *in vivo* stability and bioavailability inherent to native RNA molecules that are delivered exogenously. For example, the use of chemically modified nucleic acid molecules can enable a lower dose of a particular nucleic acid molecule for a given therapeutic effect since  
15 chemically modified nucleic acid molecules tend to have a longer half-life in serum. Furthermore, certain chemical modifications can improve the bioavailability of nucleic acid molecules by targeting particular cells or tissues and/or improving cellular uptake of the nucleic acid molecule. Therefore, even if the activity of a chemically modified nucleic acid molecule is reduced as compared to a native nucleic acid molecule, for example when  
20 compared to an all RNA nucleic acid molecule, the overall activity of the modified nucleic acid molecule can be greater than the native molecule due to improved stability and/or delivery of the molecule. Unlike native unmodified siRNA, chemically modified siNA can also minimize the possibility of activating interferon activity in humans.

In one embodiment, the invention features one or more siNA molecules and methods  
25 that independently or in combination modulate the expression of genes encoding proteins that are associated with the maintenance and/or development of a disease, condition, or trait in a cell, organism, or subject, Such genes include those encoding sequences comprising those sequences referred to by GenBank Accession Nos. described herein and in Table V of PCT/US03/05028 (International PCT Publication No. WO 03/74654), all of which genes  
30 are included within in the definition of gene(s) herein. The description below of the various aspects and embodiments of the invention is provided with reference to such exemplary genes. However, the various aspects and embodiments are also directed to other genes,

such as gene mutations, alternative splice variants, allelic variants and polymorphisms such as single nucleotide polymorphisms (SNPs) associated with the development or maintenance of a disease, condition, or trait in a cell, organism, or subject. These additional genes can be analyzed for target sites using the methods generally described for  
5 genes herein. Thus, the modulation of other genes and the effects of such modulation of the other genes can be performed, determined, and measured as described herein.

In one embodiment, the invention features a double-stranded short interfering nucleic acid (siNA) molecule that down-regulates expression of a gene, wherein said siNA molecule comprises about 19 to about 21 base pairs.

10 In one embodiment, the invention features a siNA molecule that down-regulates expression of a gene, for example, wherein the gene comprises a protein encoding sequence. In one embodiment, the invention features a siNA molecule that down-regulates expression of a gene, for example, wherein the gene comprises non-coding sequence or regulatory elements involved in gene expression.

15 In one embodiment, the invention features a siNA molecule having RNAi activity against a RNA, wherein the siNA molecule comprises a sequence complementary to any RNA having coding or non-encoding sequence, such as those sequences having GenBank Accession Nos. shown in **Table I** or sequences referred to by GenBank Accession Nos. described herein and in Table V of PCT/US03/05028 (International PCT Publication No.  
20 WO 03/74654) or otherwise known in the art. In another embodiment, the invention features a siNA molecule having RNAi activity against a RNA, wherein the siNA molecule comprises a sequence complementary to an RNA having variant (e.g., mutant, polymorphism, alternative splice variant) encoding sequence, for example other mutant genes not shown in **Table I** but known in the art to be associated with the maintenance  
25 and/or development of a disease, condition, or trait. Chemical modifications as shown in **Tables III and IV** or otherwise described herein can be applied to any siNA construct of the invention. In another embodiment, a siNA molecule of the invention includes a nucleotide sequence that can interact with nucleotide sequence of a gene and thereby mediate silencing of gene expression, for example, wherein the siNA mediates regulation  
30 of gene expression by cellular processes that modulate the chromatin structure or methylation patterns of the gene and prevent transcription of the gene.



In one embodiment, the nucleic acid molecules of the invention that act as mediators of the RNA interference gene silencing response are chemically modified double stranded nucleic acid molecules. As in their native double stranded RNA counterparts, these siNA molecules typically consist of duplexes containing about 19 base pairs between  
5 oligonucleotides comprising about 19 to about 25 nucleotides. The most active siRNA molecules are thought to have such duplexes with overhanging ends of 1-3 nucleotides, for example 21 nucleotide duplexes with 19 base pairs and 2 nucleotide 3'-overhangs. These overhanging segments are readily hydrolyzed by endonucleases *in vivo*. Studies have shown that replacing the 3'-overhanging segments of a 21-mer siRNA duplex having 2  
10 nucleotide 3' overhangs with deoxyribonucleotides does not have an adverse effect on RNAi activity. Replacing up to 4 nucleotides on each end of the siRNA with deoxyribonucleotides has been reported to be well tolerated whereas complete substitution with deoxyribonucleotides results in no RNAi activity (Elbashir et al., 2001, EMBO J., 20, 6877). In addition, Elbashir *et al, supra*, also report that substitution of siRNA with  
15 2'-O-methyl nucleotides completely abolishes RNAi activity. Li *et al.*, International PCT Publication No. WO 00/44914, and Beach *et al.*, International PCT Publication No. WO 01/68836 both suggest that siRNA may include modifications to either the phosphate-sugar back bone or the nucleoside to include at least one of a nitrogen or sulfur heteroatom, however neither application teaches to what extent these modifications are tolerated in  
20 siRNA molecules nor provide any examples of such modified siRNA. Kreutzer and Limmer, Canadian Patent Application No. 2,359,180, also describe certain chemical modifications for use in dsRNA constructs in order to counteract activation of double stranded-RNA-dependent protein kinase PKR, specifically 2'-amino or 2'-O-methyl nucleotides, and nucleotides containing a 2'-O or 4'-C methylene bridge. However,  
25 Kreutzer and Limmer similarly fail to show to what extent these modifications are tolerated in siRNA molecules nor provide any examples of such modified siRNA.

In one embodiment, the invention features chemically modified siNA constructs having specificity for target nucleic acid molecules in a cell. Non-limiting examples of such chemical modifications include without limitation phosphorothioate internucleotide  
30 linkages, 2'-O-methyl ribonucleotides, 2'-deoxy-2'-fluoro ribonucleotides, 2'-deoxy ribonucleotides, "universal base" nucleotides, 5-C-methyl nucleotides, and inverted deoxyabasic residue incorporation. These chemical modifications, when used in various

siNA constructs, are shown to preserve RNAi activity in cells while at the same time, dramatically increasing the serum stability of these compounds. Furthermore, contrary to the data published by Parrish *et al.*, *supra*, applicant demonstrates that multiple (greater than one) phosphorothioate substitutions are well-tolerated and confer substantial increases  
5 in serum stability for modified siNA constructs.

In one embodiment, the chemically-modified siNA molecules of the invention comprise a duplex having two strands, one or both of which can be chemically-modified, wherein each strand is about 19 to about 29 (e.g., about 18, 19, 20, 21, 22, 23, 24, 25, 26, 27, 28, 29 or 30) nucleotides. In one embodiment, the chemically-modified siNA molecules of  
10 the invention comprise a duplex having two strands, one or both of which can be chemically-modified, wherein each strand is about 19 to about 23 (e.g., about 18, 19, 20, 21, 22, 23 or 24) nucleotides. In one embodiment, a siNA molecule of the invention comprises modified nucleotides while maintaining the ability to mediate RNAi. The modified nucleotides can be used to improve *in vitro* or *in vivo* characteristics such as stability,  
15 activity, and/or bioavailability. For example, a siNA molecule of the invention can comprise modified nucleotides as a percentage of the total number of nucleotides present in the siNA molecule. As such, a siNA molecule of the invention can generally comprise modified nucleotides from about 5 to about 100% of the nucleotide positions (e.g., 5%, 10%, 15%, 20%, 25%, 30%, 35%, 40%, 45%, 50%, 55%, 60%, 65%, 70%, 75%, 80%, 85%,  
20 90%, 95% or 100% of the nucleotide positions). The actual percentage of modified nucleotides present in a given siNA molecule depends on the total number of nucleotides present in the siNA. If the siNA molecule is single stranded, the percent modification can be based upon the total number of nucleotides present in the single stranded siNA molecules. Likewise, if the siNA molecule is double stranded, the percent modification  
25 can be based upon the total number of nucleotides present in the sense strand, antisense strand, or both the sense and antisense strands. In addition, the actual percentage of modified nucleotides present in a given siNA molecule can also depend on the total number of purine and pyrimidine nucleotides present in the siNA, for example, wherein all pyrimidine nucleotides and/or all purine nucleotides present in the siNA molecule are  
30 modified.

The antisense region of a siNA molecule of the invention can comprise a phosphorothioate internucleotide linkage at the 3'-end of said antisense region. The

antisense region can comprise about one to about five phosphorothioate internucleotide linkages at the 5'-end of said antisense region. The 3'-terminal nucleotide overhangs of a siNA molecule of the invention can comprise ribonucleotides or deoxyribonucleotides that are chemically-modified at a nucleic acid sugar, base, or backbone. The 3'-terminal  
5 nucleotide overhangs can comprise one or more universal base ribonucleotides. The 3'-terminal nucleotide overhangs can comprise one or more acyclic nucleotides. The 3'-terminal nucleotide overhangs can comprise one or more cap moieties, such as cap moieties shown in **Figure 22**.

In one embodiment, a siNA molecule of the invention comprises blunt ends, i.e., the  
10 ends do not include any overhanging nucleotides. For example, a siNA molecule of the invention comprising modifications described herein (e.g., comprising nucleotides having Formulae I-VII or siNA constructs comprising "Stab00"- "Stab25" (**Table IV**) or any combination thereof) and/or any length described herein can comprise blunt ends or ends with no overhanging nucleotides.

15 In one embodiment, any siNA molecule of the invention can comprise one or more blunt ends, i.e. where a blunt end does not have any overhanging nucleotides. In a non-limiting example, a blunt ended siNA molecule has a number of base pairs equal to the number of nucleotides present in each strand of the siNA molecule. In another example, a siNA molecule comprises one blunt end, for example wherein the 5'-end of the antisense  
20 strand and the 3'-end of the sense strand do not have any overhanging nucleotides. In another example, a siNA molecule comprises one blunt end, for example wherein the 3'-end of the antisense strand and the 5'-end of the sense strand do not have any overhanging nucleotides. In another example, a siNA molecule comprises two blunt ends, for example wherein the 3'-end of the antisense strand and the 5'-end of the sense strand as  
25 well as the 5'-end of the antisense strand and 3'-end of the sense strand do not have any overhanging nucleotides. A blunt ended siNA molecule can comprise, for example, from about 18 to about 30 nucleotides (e.g., about 18, 18, 19, 20, 21, 22, 23, 24, 25, 26, 27, 28, 29, or 30 nucleotides). Other nucleotides present in a blunt ended siNA molecule can comprise mismatches, bulges, loops, or wobble base pairs, for example, to modulate the activity of  
30 the siNA molecule to mediate RNA interference.

By "blunt ends" is meant symmetric termini or termini of a double stranded siNA molecule having no overhanging nucleotides. The two strands of a double stranded siNA molecule align with each other without over-hanging nucleotides at the termini. For example, a blunt ended siNA construct comprises terminal nucleotides that are  
5 complimentary between the sense and antisense regions of the siNA molecule.

In one embodiment, the invention features the use of a double-stranded short interfering nucleic acid (siNA) molecule to down-regulate expression of a target gene, wherein the siNA molecule comprises one or more chemical modifications and each strand of the double-stranded siNA is about 19 to about 23 nucleotides (e.g., about 19, 20, 21, 22,  
10 or 23 nucleotides) long.

In one embodiment, the invention features a double-stranded short interfering nucleic acid (siNA) molecule that down-regulates expression of a target gene, wherein the siNA molecule comprises no ribonucleotides and each strand of the double-stranded siNA comprises about 19 to about 23 nucleotides (e.g., about 19, 20, 21, 22, or 23 nucleotides).

15 In one embodiment, one of the strands of a double-stranded siNA molecule of the invention comprises a nucleotide sequence that is complementary to a nucleotide sequence or a portion thereof of a target gene, and wherein the second strand of a double-stranded siNA molecule comprises a nucleotide sequence substantially similar to the nucleotide sequence or a portion thereof of the target gene.

20 In one embodiment, a siNA molecule of the invention comprises about 19 to about 23 nucleotides (e.g., about 19, 20, 21, 22, or 23 nucleotides), and each strand comprises at least about 19 nucleotides that are complementary to the nucleotides of the other strand.

In one embodiment, a siNA molecule of the invention comprises an antisense region comprising a nucleotide sequence that is complementary to a nucleotide sequence or a  
25 portion thereof of a target gene, and the siNA further comprises a sense region, wherein the sense region comprises a nucleotide sequence substantially similar to the nucleotide sequence or a portion thereof of the target gene. The antisense region and the sense region each comprise about 19 to about 23 nucleotides (e.g., about 19, 20, 21, 22, or 23 nucleotides), and the antisense region comprises at least about 19 nucleotides that are  
30 complementary to nucleotides of the sense region.

In one embodiment, a siNA molecule of the invention comprises a sense region and an antisense region, wherein the antisense region comprises a nucleotide sequence that is complementary to a nucleotide sequence or a portion thereof of RNA encoded by a target gene and the sense region comprises a nucleotide sequence that is complementary to the  
5 antisense region.

In one embodiment, a siNA molecule of the invention is assembled from two separate oligonucleotide fragments wherein one fragment comprises the sense region and the second fragment comprises the antisense region of the siNA molecule. In another embodiment, the sense region is connected to the antisense region via a linker molecule,  
10 which can be a polynucleotide linker or a non-nucleotide linker.

In one embodiment, a siNA molecule of the invention comprises a sense region and antisense region, wherein pyrimidine nucleotides in the sense region comprises 2'-O-methyl pyrimidine nucleotides and purine nucleotides in the sense region comprise 2'-deoxy purine nucleotides. In one embodiment, a siNA molecule of the invention comprises a sense  
15 region and antisense region, wherein pyrimidine nucleotides present in the sense region comprise 2'-deoxy-2'-fluoro pyrimidine nucleotides and wherein purine nucleotides present in the sense region comprise 2'-deoxy purine nucleotides.

In one embodiment, a siNA molecule of the invention comprises a sense region and antisense region, wherein the pyrimidine nucleotides when present in said antisense region  
20 are 2'-deoxy-2'-fluoro pyrimidine nucleotides and the purine nucleotides when present in said antisense region are 2'-O-methyl purine nucleotides.

In one embodiment, a siNA molecule of the invention comprises a sense region and antisense region, wherein the pyrimidine nucleotides when present in said antisense region  
25 are 2'-deoxy-2'-fluoro pyrimidine nucleotides and wherein the purine nucleotides when present in said antisense region comprise 2'-deoxy- purine nucleotides.

In one embodiment, a siNA molecule of the invention comprises a sense region and antisense region, wherein the sense region includes a terminal cap moiety at the 5'-end, the 3'-end, or both of the 5' and 3' ends of the sense region. In another embodiment, the terminal cap moiety is an inverted deoxy abasic moiety or any other cap moiety such as  
30 those shown in **Figure 22**.

In one embodiment, a siNA molecule of the invention has RNAi activity that modulates expression of RNA encoded by a gene. Because many genes can share some degree of sequence homology with each other, siNA molecules can be designed to target a class of genes (and associated receptor or ligand genes) or alternately specific genes by selecting sequences that are either shared amongst different gene targets or alternatively that are unique for a specific gene target. Therefore, in one embodiment, the siNA molecule can be designed to target conserved regions of a RNA sequence having sequence homology between several genes so as to target several genes or gene families (e.g., different gene isoforms, splice variants, mutant genes etc.) with one siNA molecule. In another embodiment, the siNA molecule can be designed to target a sequence that is unique to a specific RNA sequence of a specific gene due to the high degree of specificity that the siNA molecule requires to mediate RNAi activity.

In one embodiment, a siNA of the invention is used to inhibit the expression of genes or a gene family, wherein the genes or gene family sequences share sequence homology. Such homologous sequences can be identified as is known in the art, for example using sequence alignments. siNA molecules can be designed to target such homologous sequences, for example using perfectly complementary sequences or by incorporating non-canonical base pairs (e.g., mismatches and/or wobble base pairs, that can provide additional target sequences. In instances where mismatches are identified, non-canonical base pairs (e.g., mismatches and/or wobble bases) can be used to generate siNA molecules that target more than one gene sequence. In a non-limiting example, non-canonical base pairs such as UU and CC base pairs are used to generate siNA molecules that are capable of targeting differing VEGF and/or VEGFR sequences (e.g., VEGFR1 and VEGFR2). As such, one advantage of using siNAs of the invention is that a single siNA can be designed to include a nucleic acid sequence that is complementary to the nucleotide sequence that is conserved between the VEGF receptors (i.e., VEGFR1, VEGFR2, and/or VEGFR3) such that the siNA can interact with RNAs of the receptors and mediate RNAi to achieve inhibition of expression of the VEGF receptors. In this approach, a single siNA can be used to inhibit expression of more than one VEGF receptor instead of using more than one siNA molecule to target the different receptors.

In one embodiment, the invention features a siNA molecule having RNAi activity against a target RNA, wherein the siNA molecule comprises a sequence complementary to

any RNA having target gene encoding sequence, such as those sequences having GenBank Accession Nos. referred to herein. In another embodiment, the invention features a siNA molecule having RNAi activity against a target RNA, wherein the siNA molecule comprises a sequence complementary to an RNA having other sequences, for example  
5 mutant genes as are known in the art to be associated with a disease, condition, trait, genotype or phenotype. Chemical modifications as shown in **Tables I and IV** or otherwise described herein can be applied to any siNA construct of the invention. In another embodiment, a siNA molecule of the invention includes nucleotide sequence that can interact with nucleotide sequence of a target gene and thereby mediate silencing of target  
10 gene expression, for example, wherein the siNA mediates regulation of target gene expression by cellular processes that modulate the chromatin structure or methylation patterns of the target gene and prevent transcription of the target gene.

In one embodiment, siNA molecules of the invention are used to down regulate or inhibit the expression of target proteins arising from haplotype polymorphisms that are  
15 associated with a disease, condition, trait, genotype or phenotype, (e.g., associated with a gain of function). Analysis of target genes, or target protein or RNA levels can be used to identify subjects with such polymorphisms or those subjects who are at risk of developing a disease, condition, trait, genotype or phenotype. These subjects are amenable to treatment, for example, treatment with siNA molecules of the invention and any other composition  
20 useful in treating a diseases, conditions, traits, genotypes or phenotypes related to target gene expression or expressed protein activity. As such, analysis of target protein or RNA levels can be used to determine treatment type and the course of therapy in treating a subject. Monitoring of protein or RNA levels can be used to predict treatment outcome and to determine the efficacy of compounds and compositions that modulate the level and/or  
25 activity of certain proteins associated with a disease, condition, trait, genotype or phenotype.

In one embodiment, the antisense region of a siNA molecule of the invention comprises sequence complementary to a portion of a gene transcript having sequence unique to a particular disease, condition, trait, genotype or phenotype related allele, such as  
30 sequence comprising a SNP associated with the disease, condition, trait, genotype or phenotype specific allele. As such, the antisense region of a siNA molecule of the invention can comprise sequence complementary to sequences that are unique to a

particular allele to provide specificity in mediating selective RNAi against the disease, condition, trait, genotype or phenotype related allele.

In another embodiment, the invention features a siNA molecule comprising nucleotide sequence, for example, nucleotide sequence in the antisense region of the siNA molecule that is complementary to a nucleotide sequence or portion of sequence of a target gene. In another embodiment, the invention features a siNA molecule comprising a region, for example, the antisense region of the siNA construct, complementary to a sequence comprising a target gene sequence or a portion thereof.

In one embodiment of the invention a siNA molecule comprises an antisense strand having about 19 to about 29 (e.g., about 19, 20, 21, 22, 23, 24, 25, 26, 27, 28, or 29) nucleotides, wherein the antisense strand is complementary to a RNA sequence encoding a target protein, and wherein said siNA further comprises a sense strand having about 19 to about 29 (e.g., about 19, 20, 21, 22, 23, 24, 25, 26, 27, 28, or 29) nucleotides, and wherein said sense strand and said antisense strand are distinct nucleotide sequences with at least about 19 complementary nucleotides.

In another embodiment of the invention a siNA molecule of the invention comprises an antisense region having about 19 to about 29 (e.g., about 19, 20, 21, 22, 23, 24, 25, 26, 27, 28, or 29) nucleotides, wherein the antisense region is complementary to a RNA sequence encoding a target protein, and wherein said siNA further comprises a sense region having about 19 to about 29 or more (e.g., about 19, 20, 21, 22, 23, 24, 25, 26, 27, 28, 29 or more) nucleotides, wherein said sense region and said antisense region comprise a linear molecule with at least about 19 complementary nucleotides.

In one embodiment of the invention a siNA molecule comprises an antisense strand comprising a nucleotide sequence that is complementary to a nucleotide sequence or a portion thereof encoding a target protein. The siNA further comprises a sense strand, wherein said sense strand comprises a nucleotide sequence of a target gene or a portion thereof.

In another embodiment, a siNA molecule comprises an antisense region comprising a nucleotide sequence that is complementary to a nucleotide sequence encoding a target



protein or a portion thereof. The siNA molecule further comprises a sense region, wherein said sense region comprises a nucleotide sequence of a target gene or a portion thereof.

In one embodiment, a siNA molecule of the invention has RNAi activity that modulates expression of RNA encoded by a target gene. Because certain genes can share  
5 some degree of sequence homology with each other, siNA molecules can be designed to target a class of genes or alternately specific genes (e.g., polymorphic variants) by selecting sequences that are either shared amongst different targets or alternatively that are unique for a specific target. Therefore, in one embodiment, the siNA molecule can be designed to target conserved regions of RNA sequence having homology between several gene variants  
10 so as to target a class of genes with one siNA molecule. Accordingly, in one embodiment, the siNA molecule of the invention modulates the expression of one or both alleles of a target gene in a subject. In another embodiment, the siNA molecule can be designed to target a sequence that is unique to a specific target RNA sequence (e.g., a single allele or associated SNP) due to the high degree of specificity that the siNA molecule requires to  
15 mediate RNAi activity.

In one embodiment, nucleic acid molecules of the invention that act as mediators of the RNA interference gene silencing response are double-stranded nucleic acid molecules. In another embodiment, the siNA molecules of the invention consist of duplexes containing about 19 base pairs between oligonucleotides comprising about 19 to about 25 (e.g., about  
20 19, 20, 21, 22, 23, 24, or 25) nucleotides. In yet another embodiment, siNA molecules of the invention comprise duplexes with overhanging ends of about about 1 to about 3 (e.g., about 1, 2, or 3) nucleotides, for example, about 21-nucleotide duplexes with about 19 base pairs and 3'-terminal mononucleotide, dinucleotide, or trinucleotide overhangs.

One aspect of the invention features a double-stranded short interfering nucleic acid  
25 (siNA) molecule that down-regulates expression of a target gene. In one embodiment, a double stranded siNA molecule comprises one or more chemical modifications and each strand of the double-stranded siNA is about 21 nucleotides long. In one embodiment, the double-stranded siNA molecule does not contain any ribonucleotides. In another embodiment, the double-stranded siNA molecule comprises one or more ribonucleotides.  
30 In one embodiment, each strand of the double-stranded siNA molecule comprises about 19 to about 29 (e.g., about 19, 20, 21, 22, 23, 24, 25, 26, 27, 28, or 29) nucleotides, wherein

each strand comprises about 19 nucleotides that are complementary to the nucleotides of the other strand. In one embodiment, one of the strands of the double-stranded siNA molecule comprises a nucleotide sequence that is complementary to a nucleotide sequence or a portion thereof of the target gene, and the second strand of the double-stranded siNA molecule comprises a nucleotide sequence substantially similar to the nucleotide sequence  
5 of the target gene or a portion thereof.

In another embodiment, the invention features a double-stranded short interfering nucleic acid (siNA) molecule that down-regulates expression of a target gene comprising an antisense region, wherein the antisense region comprises a nucleotide sequence that is  
10 complementary to a nucleotide sequence of the target gene or a portion thereof, and a sense region, wherein the sense region comprises a nucleotide sequence substantially similar to the nucleotide sequence of the target gene or a portion thereof. In one embodiment, the antisense region and the sense region each comprise about 19 to about 23 (e.g., about 19, 20,  
15 21, 22, or 23) nucleotides, wherein the antisense region comprises about 19 nucleotides that are complementary to nucleotides of the sense region.

In another embodiment, the invention features a double-stranded short interfering nucleic acid (siNA) molecule that down-regulates expression of a target gene comprising a sense region and an antisense region, wherein the antisense region comprises a nucleotide sequence that is complementary to a nucleotide sequence of RNA encoded by the target  
20 gene or a portion thereof and the sense region comprises a nucleotide sequence that is complementary to the antisense region.

In one embodiment, a siNA of the invention is used to inhibit the expression of more than one gene, wherein the genes share some degree of sequence homology. Such homologous sequences can be identified as is known in the art, for example using sequence  
25 alignments. siNA molecules can be designed to target such homologous sequences, for example using perfectly complementary sequences or by incorporating mismatches and/or wobble base pairs that can provide additional target sequences. One advantage of using siNAs of the invention is that a single siNA can be designed to include nucleic acid sequence that is complementary to a nucleotide sequence that is conserved between the  
30 genes such that the siNA can interact with RNA transcripts of the genes and mediate RNAi to achieve inhibition of expression of the genes. In this approach, a single siNA can be used

to inhibit expression of more than one gene, thereby obviating the need to use more than one siNA molecule to target the different genes. The different genes can comprise, for example, a cytokine and its corresponding receptor(s).

5 In one embodiment, the invention features a method of designing a single siNA to inhibit the expression of two or more genes comprising designing a siNA having nucleotide sequence that is complementary to nucleotide sequence encoded by or present in the genes or a portion thereof, wherein the siNA mediates RNAi to inhibit the expression of the genes. For example, a single siNA can inhibit the expression of two genes by binding to conserved or homologous sequence present in RNA encoded by both genes or a portion thereof.

10 In one embodiment, nucleic acid molecules of the invention that act as mediators of the RNA interference gene silencing response are double-stranded nucleic acid molecules. In another embodiment, the siNA molecules of the invention consist of duplexes containing about 19 base pairs between oligonucleotides comprising about 19 to about 25 (*e.g.*, about 19, 20, 21, 22, 23, 24, or 25) nucleotides. In yet another embodiment, siNA molecules of  
15 the invention comprise duplexes with overhanging ends of about 1 to about 3 (*e.g.*, about 1, 2, or 3) nucleotides, for example, about 21-nucleotide duplexes with about 19 base pairs and 3'-terminal mononucleotide, dinucleotide, or trinucleotide overhangs.

In one embodiment, the invention features one or more chemically-modified siNA constructs having specificity for nucleic acid molecules that express or encode a protein  
20 sequence, such as RNA or DNA encoding a protein sequence. Non-limiting examples of such chemical modifications include without limitation phosphorothioate internucleotide linkages, 2'-deoxyribonucleotides, 2'-O-methyl ribonucleotides, 2'-deoxy-2'-fluoro ribonucleotides, "universal base" nucleotides, "acyclic" nucleotides, 5-C-methyl nucleotides, and terminal glyceryl and/or inverted deoxy abasic residue incorporation.  
25 These chemical modifications, when used in various siNA constructs, are shown to preserve RNAi activity in cells while at the same time, dramatically increasing the serum stability of these compounds.

In one embodiment, a siNA molecule of the invention does not contain any ribonucleotides. In another embodiment, a siNA molecule of the invention comprises one  
30 or more ribonucleotides.

In one embodiment, the invention features the use of compounds or compositions that inhibit the activity of double stranded RNA binding proteins (dsRBPs, see for example Silhavy *et al.*, 2003, *Journal of General Virology*, 84, 975-980). Non-limiting examples of compounds and compositions that can be used to inhibit the activity of dsRBPs include but are not limited to small molecules and nucleic acid aptamers that bind to or interact with the dsRBPs and consequently reduce dsRBP activity and/or siNA molecules that target nucleic acid sequences encoding dsRBPs. The use of such compounds and compositions is expected to improve the activity of siNA molecules in biological systems in which dsRBPs can abrogate or suppress the efficacy of siNA mediated RNA interference, such as where dsRBPs are expressed during viral infection of a cell to escape RNAi surveillance. Therefore, the use of agents that inhibit dsRBP activity is preferred in those instances where RNA interference activity can be improved via the abrogation or suppression of dsRBP activity. Such anti-dsRBP agents can be administered alone or can be co-administered with siNA molecules of the invention, or can be used to pretreat cells or a subject before siNA administration. In another embodiment, anti-dsRBP agents are used to treat viral infection, such as HCV, HBV, or HIV infection with or without siNA molecules of the invention.

In one embodiment, the invention features a double-stranded short interfering nucleic acid (siNA) molecule that down-regulates expression of a gene, wherein one of the strands of the double-stranded siNA molecule comprises a nucleotide sequence that is complementary to a nucleotide sequence of the gene or RNA encoded by the gene or a portion thereof, and wherein the second strand of the double-stranded siNA molecule comprises a nucleotide sequence substantially similar to the nucleotide sequence of the gene or RNA encoded by the gene or a portion thereof.

In one embodiment, the invention features a double-stranded short interfering nucleic acid (siNA) molecule that down-regulates expression of a gene, wherein each strand of the siNA molecule comprises about 19 to about 23 nucleotides, and wherein each strand comprises at least about 19 nucleotides that are complementary to the nucleotides of the other strand.

In one embodiment, the invention features a double-stranded short interfering nucleic acid (siNA) molecule that down-regulates expression of a gene, wherein the siNA molecule

comprises an antisense region comprising a nucleotide sequence that is complementary to a nucleotide sequence of the gene or RNA encoded by the gene or a portion thereof, and wherein the siNA further comprises a sense region, wherein the sense region comprises a nucleotide sequence substantially similar to the nucleotide sequence of the gene or RNA  
5 encoded by the gene or a portion thereof.

In one embodiment, the invention features a double-stranded short interfering nucleic acid (siNA) molecule that inhibits the expression of a target gene by mediating RNA interference (RNAi) process, wherein the siNA molecule comprises no ribonucleotides and wherein each strand of the double-stranded siNA molecule comprises about 21 nucleotides.

10 In one embodiment, the invention features a double-stranded short interfering nucleic acid (siNA) molecule that inhibits the replication of a virus (e.g. as mammalian virus, plant virus, hepatitis C virus, human immunodeficiency virus, hepatitis B virus, herpes simplex virus, cytomegalovirus, human papilloma virus, respiratory syncytial virus, or influenza virus), wherein the siNA molecule does not require the presence of a ribonucleotide within  
15 the siNA molecule for the inhibition of replication of the virus and each strand of the double-stranded siNA molecule comprises about 21 nucleotides.

In one embodiment, the invention features a double-stranded short interfering nucleic acid (siNA) molecule that down-regulates expression of a gene, wherein the siNA molecule comprises a sense region and an antisense region and wherein the antisense region  
20 comprises a nucleotide sequence that is complementary to a nucleotide sequence or a portion thereof of RNA encoded by the gene and the sense region comprises a nucleotide sequence that is complementary to the antisense region or a portion thereof, and wherein the purine nucleotides present in the antisense region comprise 2'-deoxy- purine nucleotides. In another embodiment, the purine nucleotides present in the antisense region  
25 comprise 2'-O-methyl purine nucleotides. In either of the above embodiments, the antisense region comprises a phosphorothioate internucleotide linkage at the 3' end of the antisense region. In an alternative embodiment, the antisense region comprises a glyceryl modification at the 3' end of the antisense region. In another embodiment of any of the above described siNA molecules, any nucleotides present in a non-complementary region  
30 of the antisense strand (e.g., overhang region) are 2'-deoxy nucleotides.

In one embodiment, the invention features a double-stranded short interfering nucleic acid (siNA) molecule that down-regulates expression of a gene, wherein the siNA molecule is assembled from two separate oligonucleotide fragments each comprising 21 nucleotides, wherein one fragment comprises the sense region and the second fragment comprises the antisense region of the siNA molecule, and wherein about 19 nucleotides of each fragment of the siNA molecule are base-paired to the complementary nucleotides of the other fragment of the siNA molecule and wherein at least two 3' terminal nucleotides of each fragment of the siNA molecule are not base-paired to the nucleotides of the other fragment of the siNA molecule. In one embodiment, each of the two 3' terminal nucleotides of each fragment of the siNA molecule is a 2'-deoxy-pyrimidine nucleotide, such as 2'-deoxy-thymidine. In another embodiment, all 21 nucleotides of each fragment of the siNA molecule are base-paired to the complementary nucleotides of the other fragment of the siNA molecule. In another embodiment, about 19 nucleotides of the antisense region are base-paired to the nucleotide sequence or a portion thereof of the RNA encoded by the gene. In another embodiment, 21 nucleotides of the antisense region are base-paired to the nucleotide sequence or a portion thereof of the RNA encoded by the gene. In any of the above embodiments, the 5'-end of the fragment comprising said antisense region can optionally include a phosphate group.

In one embodiment, the invention features a double-stranded short interfering nucleic acid (siNA) molecule that inhibits the expression of a RNA sequence (e.g., wherein said target RNA sequence is encoded by a gene or a gene involved in a pathway of gene expression), wherein the siNA molecule does not contain any ribonucleotides and wherein each strand of the double-stranded siNA molecule is about 21 nucleotides long. Examples of non-ribonucleotide containing siNA constructs are combinations of stabilization chemistries shown in **Table IV** in any combination of Sense/Antisense chemistries, e.g., Stab 7/8, Stab 7/11, Stab 8/8, Stab 18/8, Stab 18/11, Stab 12/13, Stab 7/13, Stab 18/13, Stab 7/19, Stab 8/19, Stab 18/19, Stab 7/20, Stab 8/20, or Stab 18/20.

In one embodiment, the invention features a chemically synthesized double stranded RNA molecule that directs cleavage of a target RNA via RNA interference, wherein each strand of said RNA molecule is about 21 to about 23 nucleotides in length; one strand of the RNA molecule comprises nucleotide sequence having sufficient complementarity to the target RNA for the RNA molecule to direct cleavage of the target RNA via RNA

interference; and wherein at least one strand of the RNA molecule comprises one or more chemically modified nucleotides described herein, such as deoxynucleotides, 2'-O-methyl nucleotides, 2'-deoxy-2'-fluoro nucleotides, 2'-O-methoxyethyl nucleotides etc.

5 In one embodiment, the invention features a medicament comprising a siNA molecule of the invention.

In one embodiment, the invention features an active ingredient comprising a siNA molecule of the invention.

10 In one embodiment, the invention features the use of a double-stranded short interfering nucleic acid (siNA) molecule to down-regulate expression of a target gene, wherein the siNA molecule comprises one or more chemical modifications and each strand of the double-stranded siNA is about 21 nucleotides long.

15 In one embodiment, the invention features the use of a double-stranded short interfering nucleic acid (siNA) molecule to down-regulate expression of a target gene, wherein the siNA molecule comprises one or more chemical modifications and each strand of the double-stranded siNA is about 18 to about 28 or more (e.g., 17, 18, 19, 20, 21, 22, 23, 24, 25, 26, 27, 28 or more) nucleotides long.

20 The invention features a double-stranded short interfering nucleic acid (siNA) molecule that inhibits expression of a gene, wherein one of the strands of the double-stranded siNA molecule is an antisense strand which comprises nucleotide sequence that is complementary to nucleotide sequence of a RNA encoded by the gene or a portion thereof, the other strand is a sense strand which comprises nucleotide sequence that is complementary to a nucleotide sequence of the antisense strand and wherein a majority of the pyrimidine nucleotides present in the double-stranded siNA molecule comprises a sugar modification.

25 In one embodiment, the nucleotide sequence of the antisense strand of a siNA molecule of the invention is complementary to the nucleotide sequence of a RNA which encodes a protein or a portion thereof. In one embodiment, each strand of the siNA molecule comprises about 19 to about 29 (e.g., about 18, 19, 20, 21, 22, 23, 24, 25, 26, 27,

28, 29 or 30) nucleotides, and each strand comprises at least about 19 nucleotides that are complementary to the nucleotides of the other strand.

In one embodiment, a siNA molecule of the invention is assembled from two oligonucleotide fragments, wherein one fragment comprises the nucleotide sequence of the antisense strand of the siNA molecule and a second fragment comprises nucleotide sequence of the sense region of the siNA molecule. In another embodiment, the sense strand is connected to the antisense strand via a linker molecule, such as a polynucleotide linker or a non-nucleotide linker.

In one embodiment, of a siNA molecule of the invention, the pyrimidine nucleotides present in the sense strand are 2'-deoxy-2'-fluoro pyrimidine nucleotides and the purine nucleotides present in the sense region are 2'-deoxy purine nucleotides. In another embodiment, the pyrimidine nucleotides present in the sense strand are 2'-deoxy-2'-fluoro pyrimidine nucleotides and the purine nucleotides present in the sense region are 2'-O-methyl purine nucleotides. In one embodiment, the sense strand comprises a 3'-end and a 5'-end, wherein a terminal cap moiety (e.g., an inverted deoxy abasic moiety) is present at the 5'-end, the 3'-end, or both of the 5' and 3' ends of the sense strand. In one embodiment, the antisense strand comprises one or more 2'-deoxy-2'-fluoro pyrimidine nucleotides and one or more 2'-O-methyl purine nucleotides. In one embodiment, the pyrimidine nucleotides present in the antisense strand are 2'-deoxy-2'-fluoro pyrimidine nucleotides and any purine nucleotides present in the antisense strand are 2'-O-methyl purine nucleotides. In one embodiment, the antisense strand comprises a phosphorothioate internucleotide linkage at the 3' end of the antisense strand. In another embodiment, the antisense strand comprises a glyceryl modification at the 3' end. In another embodiment, the 5'-end of the antisense strand optionally includes a phosphate group.

In one embodiment, the invention features a double-stranded short interfering nucleic acid (siNA) molecule that down-regulates expression of a gene, wherein one of the strands of the double-stranded siNA molecule is an antisense strand which comprises nucleotide sequence that is complementary to nucleotide sequence of RNA encoded by a gene or a portion thereof, the other strand is a sense strand which comprises nucleotide sequence that is complementary to a nucleotide sequence of the antisense strand and wherein a majority of the pyrimidine nucleotides present in the double-stranded siNA molecule comprises a



sugar modification, and wherein the nucleotide sequence of the antisense strand is complementary to a nucleotide sequence of the 5'-untranslated region or a portion thereof of the RNA. In another embodiment, the nucleotide sequence of the antisense strand is complementary to a nucleotide sequence of the RNA or a portion thereof.

5           In one embodiment, the invention features a double-stranded short interfering nucleic acid (siNA) molecule that inhibits expression of a gene, wherein one of the strands of the double-stranded siNA molecule is an antisense strand which comprises nucleotide sequence that is complementary to nucleotide sequence of a RNA or a portion thereof, the other strand is a sense strand which comprises nucleotide sequence that is complementary  
10 to a nucleotide sequence of the antisense strand and wherein a majority of the pyrimidine nucleotides present in the double-stranded siNA molecule comprises a sugar modification, and wherein each of the two strands of the siNA molecule comprises 21 nucleotides. In one embodiment, about 19 nucleotides of each strand of the siNA molecule are base-paired to the complementary nucleotides of the other strand of the siNA molecule and at least two 3'  
15 terminal nucleotides of each strand of the siNA molecule are not base-paired to the nucleotides of the other strand of the siNA molecule. In one embodiment, each of the two 3' terminal nucleotides of each fragment of the siNA molecule are 2'-deoxy-pyrimidines, such as 2'-deoxy-thymidine. In another embodiment, each strand of the siNA molecule is base-paired to the complementary nucleotides of the other strand of the siNA molecule. In  
20 one embodiment, about 19 nucleotides of the antisense strand are base-paired to the nucleotide sequence of the RNA or a portion thereof. In another embodiment, 21 nucleotides of the antisense strand are base-paired to the nucleotide sequence of the RNA or a portion thereof.

25           In one embodiment, the invention features a composition comprising a siNA molecule of the invention and a pharmaceutically acceptable carrier or diluent.

          In one embodiment, the invention features a method of increasing the stability of a siNA molecule against cleavage by ribonucleases comprising introducing at least one modified nucleotide into the siNA molecule, wherein the modified nucleotide is a  
30 2'-deoxy-2'-fluoro nucleotide. In another embodiment, all pyrimidine nucleotides present in the siNA are 2'-deoxy-2'-fluoro pyrimidine nucleotides. In another embodiment, the modified nucleotides in the siNA include at least one 2'-deoxy-2'-fluoro cytidine or

2'-deoxy-2'-fluoro uridine nucleotide. In another embodiment, the modified nucleotides in the siNA include at least one 2'-fluoro cytidine and at least one 2'-deoxy-2'-fluoro uridine nucleotides. In another embodiment, all uridine nucleotides present in the siNA are 2'-deoxy-2'-fluoro uridine nucleotides. In another embodiment, all cytidine nucleotides present in the siNA are 2'-deoxy-2'-fluoro cytidine nucleotides. In another embodiment, all adenosine nucleotides present in the siNA are 2'-deoxy-2'-fluoro adenosine nucleotides. In another embodiment, all guanosine nucleotides present in the siNA are 2'-deoxy-2'-fluoro guanosine nucleotides. The siNA can further comprise at least one modified internucleotidic linkage, such as phosphorothioate linkage. In another embodiment, the 2'-deoxy-2'-fluoronucleotides are present at specifically selected locations in the siNA that are sensitive to cleavage by ribonucleases, such as locations having pyrimidine nucleotides.

In one embodiment, the invention features the use of a double-stranded short interfering nucleic acid (siNA) molecule that inhibits expression of a gene, wherein one of the strands of the double-stranded siNA molecule is an antisense strand which comprises nucleotide sequence that is complementary to nucleotide sequence of a RNA or a portion thereof, the other strand is a sense strand which comprises nucleotide sequence that is complementary to a nucleotide sequence of the antisense strand and wherein a majority of the pyrimidine nucleotides present in the double-stranded siNA molecule comprises a sugar modification.

In one embodiment, the invention features a short interfering nucleic acid (siNA) molecule comprising a double-stranded structure that down-regulates expression of a target nucleic acid, wherein the siNA molecule does not require a 2'-hydroxyl group containing ribonucleotide, each strand of the double-stranded structure of the siNA molecule comprises about 21 nucleotides and the siNA molecule comprises nucleotide sequence having complementarity to nucleotide sequence of the target nucleic acid or a portion thereof. The target nucleic acid can be an endogenous gene, an exogenous gene, a viral nucleic acid, or a RNA, such as a mammalian gene, plant gene, viral gene, fungal gene, bacterial gene, plant viral gene, or mammalian viral gene. Examples of mammalian viral gene include hepatitis C virus, human immunodeficiency virus, hepatitis B virus, herpes simplex virus, cytomegalovirus, human papilloma virus, respiratory syncytial virus, influenza virus, and severe acute respiratory syndrome virus (SARS).

In one embodiment, a siNA molecule of the invention comprises a sense region and an antisense region wherein the antisense region comprises the nucleotide sequence that is complementary to a nucleotide sequence or a portion thereof of the target nucleic acid and the sense region comprises a nucleotide sequence that is complementary to nucleotide  
5 sequence of the antisense region or a portion thereof.

In one embodiment, a siNA molecule of the invention is assembled from two separate oligonucleotide fragments wherein one fragment comprises the sense region and the second fragment comprises the antisense region of the siNA molecule. The sense region can be connected to the antisense region via a linker molecule, such as a  
10 polynucleotide linker or non-nucleotide linker. In another embodiment, each sense region and antisense region comprise about 21 nucleotides in length. In another embodiment, about 19 nucleotides of each fragment of the siNA molecule are base-paired to the complementary nucleotides of the other fragment of the siNA molecule and at least two 3' terminal nucleotides of each fragment of the siNA molecule are not base-paired to the  
15 nucleotides of the other fragment of the siNA molecule. In another embodiment, each of the two 3' terminal nucleotides of each fragment of the siNA molecule are 2'-deoxy-pyrimidines, such as the thymidine. In another embodiment, all 21 nucleotides of each fragment of the siNA molecule are base-paired to the complementary nucleotides of the other fragment of the siNA molecule. In another embodiment, about 19 nucleotides of  
20 the antisense region of the siNA molecule are base-paired to the nucleotide sequence or a portion thereof of the the target nucleic acid. In another embodiment, 21 nucleotides of the antisense region of the siNA molecule are base-paired to the nucleotide sequence or a portion thereof of the target nucleic acid. In another embodiment, the 5'-end of the fragment comprising the antisense region optionally includes a phosphate group.

25 In one embodiment, a siNA molecule of the invention comprises nucleotide sequence having complementarity to nucleotide sequence of RNA or a portion thereof encoded by the target nucleic acid or a portion thereof.

In one embodiment, a siNA molecule of the invention comprises a sense region and an antisense region, wherein the pyrimidine nucleotides when present in the sense region  
30 are 2'-O-methyl pyrimidine nucleotides and wherein the purine nucleotides when present in the sense region are 2'-deoxy purine nucleotides.

In one embodiment, a siNA molecule of the invention comprises a sense region and an antisense region, wherein the pyrimidine nucleotides when present in the sense region are 2'-deoxy-2'-fluoro pyrimidine nucleotides and wherein the purine nucleotides when present in the sense region are 2'-deoxy purine nucleotides.

5 In one embodiment, a siNA molecule of the invention comprises a sense region and an antisense region, wherein the sense region includes a terminal cap moiety at the 5'-end, the 3'-end, or both of the 5' and 3' ends. The cap moiety can be an inverted deoxy abasic moiety, an inverted deoxy thymidine moiety, or a thymidine moiety.

10 In one embodiment, a siNA molecule of the invention comprises a sense region and an antisense region, wherein the pyrimidine nucleotides when present in the antisense region are 2'-deoxy-2'-fluoro pyrimidine nucleotides and the purine nucleotides when present in the antisense region are 2'-O-methyl purine nucleotides.

15 In one embodiment, a siNA molecule of the invention comprises a sense region and an antisense region, wherein the pyrimidine nucleotides when present in the antisense region are 2'-deoxy-2'-fluoro pyrimidine nucleotides and wherein the purine nucleotides when present in the antisense region comprise 2'-deoxy- purine nucleotides.

20 In one embodiment, a siNA molecule of the invention comprises a sense region and an antisense region, wherein the antisense region comprises a phosphate backbone modification at the 3' end of the antisense region. The phosphate backbone modification can be a phosphorothioate.

In one embodiment, a siNA molecule of the invention comprises a sense region and an antisense region, wherein the antisense region comprises a glyceryl modification at the 3' end of the antisense region.

25 In one embodiment, a siNA molecule of the invention comprises a sense region and an antisense region, wherein each of sense and the antisense regions of the siNA molecule comprise about 21 nucleotides.

In a non-limiting example, the introduction of chemically-modified nucleotides into nucleic acid molecules provides a powerful tool in overcoming potential limitations of *in vivo* stability and bioavailability inherent to native RNA molecules that are delivered

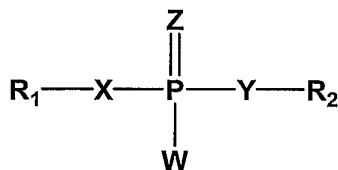
exogenously. For example, the use of chemically-modified nucleic acid molecules can enable a lower dose of a particular nucleic acid molecule for a given therapeutic effect since chemically-modified nucleic acid molecules tend to have a longer half-life in serum. Furthermore, certain chemical modifications can improve the bioavailability of nucleic acid molecules by targeting particular cells or tissues and/or improving cellular uptake of the nucleic acid molecule. Therefore, even if the activity of a chemically-modified nucleic acid molecule is reduced as compared to a native nucleic acid molecule, for example, when compared to an all-RNA nucleic acid molecule, the overall activity of the modified nucleic acid molecule can be greater than that of the native molecule due to improved stability and/or delivery of the molecule. Unlike native unmodified siNA, chemically-modified siNA can also minimize the possibility of activating interferon activity in humans.

In any of the embodiments of siNA molecules described herein, the antisense region of a siNA molecule of the invention can comprise a phosphorothioate internucleotide linkage at the 3'-end of said antisense region. In any of the embodiments of siNA molecules described herein, the antisense region can comprise about one to about five phosphorothioate internucleotide linkages at the 5'-end of said antisense region. In any of the embodiments of siNA molecules described herein, the 3'-terminal nucleotide overhangs of a siNA molecule of the invention can comprise ribonucleotides or deoxyribonucleotides that are chemically-modified at a nucleic acid sugar, base, or backbone. In any of the embodiments of siNA molecules described herein, the 3'-terminal nucleotide overhangs can comprise one or more universal base ribonucleotides. In any of the embodiments of siNA molecules described herein, the 3'-terminal nucleotide overhangs can comprise one or more acyclic nucleotides.

One embodiment of the invention provides an expression vector comprising a nucleic acid sequence encoding at least one siNA molecule of the invention in a manner that allows expression of the nucleic acid molecule. Another embodiment of the invention provides a mammalian cell comprising such an expression vector. The mammalian cell can be a human cell. The siNA molecule of the expression vector can comprise a sense region and an antisense region. The antisense region can comprise sequence complementary to an RNA or DNA sequence encoding a protein or polypeptide and the sense region can comprise sequence complementary to the antisense region. The siNA molecule can comprise two distinct strands having complementary sense and antisense regions. The

siNA molecule can comprise a single strand having complementary sense and antisense regions.

In one embodiment, the invention features a chemically-modified short interfering nucleic acid (siNA) molecule capable of mediating RNA interference (RNAi) inside a cell or reconstituted *in vitro* system, wherein the chemical modification comprises one or more  
 5 (e.g., about 1, 2, 3, 4, 5, 6, 7, 8, 9, 10, or more) nucleotides comprising a backbone modified internucleotide linkage having Formula I:

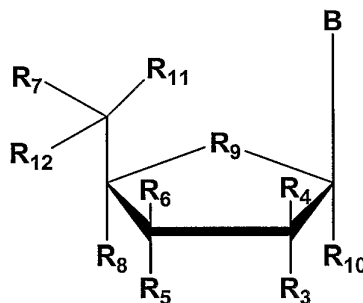


wherein each R<sub>1</sub> and R<sub>2</sub> is independently any nucleotide, non-nucleotide, or  
 10 polynucleotide which can be naturally-occurring or chemically-modified, each X and Y is independently O, S, N, alkyl, or substituted alkyl, each Z and W is independently O, S, N, alkyl, substituted alkyl, O-alkyl, S-alkyl, alkaryl, or aralkyl, and wherein W, X, Y, and Z are optionally not all O. In another embodiment, a backbone modification of the invention comprises a phosphonoacetate and/or thiophosphonoacetate internucleotide linkage (see  
 15 for example Sheehan et al., 2003, *Nucleic Acids Research*, 31, 4109-4118).

The chemically-modified internucleotide linkages having Formula I, for example, wherein any Z, W, X, and/or Y independently comprises a sulphur atom, can be present in one or both oligonucleotide strands of the siNA duplex, for example, in the sense strand, the antisense strand, or both strands. The siNA molecules of the invention can comprise  
 20 one or more (e.g., about 1, 2, 3, 4, 5, 6, 7, 8, 9, 10, or more) chemically-modified internucleotide linkages having Formula I at the 3'-end, the 5'-end, or both of the 3' and 5'-ends of the sense strand, the antisense strand, or both strands. For example, an exemplary siNA molecule of the invention can comprise about 1 to about 5 or more (e.g., about 1, 2, 3, 4, 5, or more) chemically-modified internucleotide linkages having Formula I  
 25 at the 5'-end of the sense strand, the antisense strand, or both strands. In another non-limiting example, an exemplary siNA molecule of the invention can comprise one or more (e.g., about 1, 2, 3, 4, 5, 6, 7, 8, 9, 10, or more) pyrimidine nucleotides with chemically-modified internucleotide linkages having Formula I in the sense strand, the

antisense strand, or both strands. In yet another non-limiting example, an exemplary siNA molecule of the invention can comprise one or more (*e.g.*, about 1, 2, 3, 4, 5, 6, 7, 8, 9, 10, or more) purine nucleotides with chemically-modified internucleotide linkages having Formula I in the sense strand, the antisense strand, or both strands. In another embodiment, a siNA molecule of the invention having internucleotide linkage(s) of Formula I also comprises a chemically-modified nucleotide or non-nucleotide having any of Formulae I-VII.

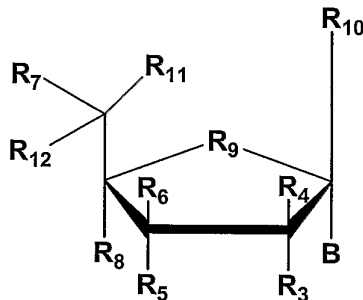
In one embodiment, the invention features a chemically-modified short interfering nucleic acid (siNA) molecule capable of mediating RNA interference (RNAi) inside a cell or reconstituted *in vitro* system, wherein the chemical modification comprises one or more (*e.g.*, about 1, 2, 3, 4, 5, 6, 7, 8, 9, 10, or more) nucleotides or non-nucleotides having Formula II:



wherein each R<sub>3</sub>, R<sub>4</sub>, R<sub>5</sub>, R<sub>6</sub>, R<sub>7</sub>, R<sub>8</sub>, R<sub>10</sub>, R<sub>11</sub> and R<sub>12</sub> is independently H, OH, alkyl, substituted alkyl, alkaryl or aralkyl, F, Cl, Br, CN, CF<sub>3</sub>, OCF<sub>3</sub>, OCN, O-alkyl, S-alkyl, N-alkyl, O-alkenyl, S-alkenyl, N-alkenyl, SO-alkyl, alkyl-OSH, alkyl-OH, O-alkyl-OH, O-alkyl-SH, S-alkyl-OH, S-alkyl-SH, alkyl-S-alkyl, alkyl-O-alkyl, ONO<sub>2</sub>, NO<sub>2</sub>, N<sub>3</sub>, NH<sub>2</sub>, aminoalkyl, aminoacid, aminoacyl, ONH<sub>2</sub>, O-aminoalkyl, O-aminoacid, O-aminoacyl, heterocycloalkyl, heterocycloalkaryl, aminoalkylamino, polyalkylamino, substituted silyl, or group having Formula I or II; R<sub>9</sub> is O, S, CH<sub>2</sub>, S=O, CHF, or CF<sub>2</sub>, and B is a nucleosidic base such as adenine, guanine, uracil, cytosine, thymine, 2-aminoadenosine, 5-methylcytosine, 2,6-diaminopurine, or any other non-naturally occurring base that can be complementary or non-complementary to target RNA or a non-nucleosidic base such as phenyl, naphthyl, 3-nitropyrrole, 5-nitroindole, nebularine, pyridone, pyridinone, or any other non-naturally occurring universal base that can be complementary or non-complementary to target RNA.

The chemically-modified nucleotide or non-nucleotide of Formula II can be present in one or both oligonucleotide strands of the siNA duplex, for example in the sense strand, the antisense strand, or both strands. The siNA molecules of the invention can comprise one or more chemically-modified nucleotide or non-nucleotide of Formula II at the 3'-end, the 5'-end, or both of the 3' and 5'-ends of the sense strand, the antisense strand, or both strands. For example, an exemplary siNA molecule of the invention can comprise about 1 to about 5 or more (*e.g.*, about 1, 2, 3, 4, 5, or more) chemically-modified nucleotides or non-nucleotides of Formula II at the 5'-end of the sense strand, the antisense strand, or both strands. In another non-limiting example, an exemplary siNA molecule of the invention can comprise about 1 to about 5 or more (*e.g.*, about 1, 2, 3, 4, 5, or more) chemically-modified nucleotides or non-nucleotides of Formula II at the 3'-end of the sense strand, the antisense strand, or both strands.

In one embodiment, the invention features a chemically-modified short interfering nucleic acid (siNA) molecule capable of mediating RNA interference (RNAi) inside a cell or reconstituted *in vitro* system, wherein the chemical modification comprises one or more (*e.g.*, about 1, 2, 3, 4, 5, 6, 7, 8, 9, 10, or more) nucleotides or non-nucleotides having Formula III:



wherein each R<sub>3</sub>, R<sub>4</sub>, R<sub>5</sub>, R<sub>6</sub>, R<sub>7</sub>, R<sub>8</sub>, R<sub>10</sub>, R<sub>11</sub> and R<sub>12</sub> is independently H, OH, alkyl, substituted alkyl, alkaryl or aralkyl, F, Cl, Br, CN, CF<sub>3</sub>, OCF<sub>3</sub>, OCN, O-alkyl, S-alkyl, N-alkyl, O-alkenyl, S-alkenyl, N-alkenyl, SO-alkyl, alkyl-OSH, alkyl-OH, O-alkyl-OH, O-alkyl-SH, S-alkyl-OH, S-alkyl-SH, alkyl-S-alkyl, alkyl-O-alkyl, ONO<sub>2</sub>, NO<sub>2</sub>, N<sub>3</sub>, NH<sub>2</sub>, aminoalkyl, aminoacid, aminoacyl, ONH<sub>2</sub>, O-aminoalkyl, O-aminoacid, O-aminoacyl, heterocycloalkyl, heterocycloalkaryl, aminoalkylamino, polyalkylamino, substituted silyl, or group having Formula I or II; R<sub>9</sub> is O, S, CH<sub>2</sub>, S=O, CHF, or CF<sub>2</sub>, and B is a nucleosidic base such as adenine, guanine, uracil, cytosine, thymine, 2-aminoadenosine,

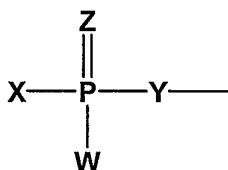


5-methylcytosine, 2,6-diaminopurine, or any other non-naturally occurring base that can be employed to be complementary or non-complementary to target RNA or a non-nucleosidic base such as phenyl, naphthyl, 3-nitropyrrole, 5-nitroindole, nebularine, pyridone, pyridinone, or any other non-naturally occurring universal base that can be complementary  
 5 or non-complementary to target RNA.

The chemically-modified nucleotide or non-nucleotide of Formula III can be present in one or both oligonucleotide strands of the siNA duplex, for example, in the sense strand, the antisense strand, or both strands. The siNA molecules of the invention can comprise one or more chemically-modified nucleotide or non-nucleotide of Formula III at the 3'-end,  
 10 the 5'-end, or both of the 3' and 5'-ends of the sense strand, the antisense strand, or both strands. For example, an exemplary siNA molecule of the invention can comprise about 1 to about 5 or more (*e.g.*, about 1, 2, 3, 4, 5, or more) chemically-modified nucleotide(s) or non-nucleotide(s) of Formula III at the 5'-end of the sense strand, the antisense strand, or both strands. In another non-limiting example, an exemplary siNA molecule of the  
 15 invention can comprise about 1 to about 5 or more (*e.g.*, about 1, 2, 3, 4, 5, or more) chemically-modified nucleotide or non-nucleotide of Formula III at the 3'-end of the sense strand, the antisense strand, or both strands.

In another embodiment, a siNA molecule of the invention comprises a nucleotide having Formula II or III, wherein the nucleotide having Formula II or III is in an inverted  
 20 configuration. For example, the nucleotide having Formula II or III is connected to the siNA construct in a 3'-3', 3'-2', 2'-3', or 5'-5' configuration, such as at the 3'-end, the 5'-end, or both of the 3' and 5'-ends of one or both siNA strands.

In one embodiment, the invention features a chemically-modified short interfering nucleic acid (siNA) molecule capable of mediating RNA interference (RNAi) inside a cell  
 25 or reconstituted *in vitro* system, wherein the chemical modification comprises a 5'-terminal phosphate group having Formula IV:



wherein each X and Y is independently O, S, N, alkyl, substituted alkyl, or alkylhalo; wherein each Z and W is independently O, S, N, alkyl, substituted alkyl, O-alkyl, S-alkyl, alkaryl, aralkyl, or alkylhalo or acetyl; and/or wherein W, X, Y and Z are not all O.

5 In one embodiment, the invention features a siNA molecule having a 5'-terminal phosphate group having Formula IV on the target-complementary strand, for example, a strand complementary to a target RNA, wherein the siNA molecule comprises an all RNA siNA molecule. In another embodiment, the invention features a siNA molecule having a 5'-terminal phosphate group having Formula IV on the target-complementary strand wherein the siNA molecule also comprises about 1 to about 3 (*e.g.*, about 1, 2, or 3) 10 nucleotide 3'-terminal nucleotide overhangs having about 1 to about 4 (*e.g.*, about 1, 2, 3, or 4) deoxyribonucleotides on the 3'-end of one or both strands. In another embodiment, a 5'-terminal phosphate group having Formula IV is present on the target-complementary strand of a siNA molecule of the invention, for example a siNA molecule having chemical modifications having any of Formulae I-VII.

15 In one embodiment, the invention features a chemically-modified short interfering nucleic acid (siNA) molecule capable of mediating RNA interference (RNAi) inside a cell or reconstituted *in vitro* system, wherein the chemical modification comprises one or more phosphorothioate, phosphonoacetate, and/or thiophosphonoacetate internucleotide linkages. For example, in a non-limiting example, the invention features a 20 chemically-modified short interfering nucleic acid (siNA) having about 1, 2, 3, 4, 5, 6, 7, 8 or more phosphorothioate internucleotide linkages in one siNA strand. In yet another embodiment, the invention features a chemically-modified short interfering nucleic acid (siNA) individually having about 1, 2, 3, 4, 5, 6, 7, 8 or more phosphorothioate internucleotide linkages in both siNA strands. The phosphorothioate internucleotide 25 linkages can be present in one or both oligonucleotide strands of the siNA duplex, for example in the sense strand, the antisense strand, or both strands. The siNA molecules of the invention can comprise one or more phosphorothioate, phosphonoacetate, and/or thiophosphonoacetate internucleotide linkages at the 3'-end, the 5'-end, or both of the 3'- and 5'-ends of the sense strand, the antisense strand, or both strands. For example, an 30 exemplary siNA molecule of the invention can comprise about 1 to about 5 or more (*e.g.*, about 1, 2, 3, 4, 5, or more) consecutive phosphorothioate internucleotide linkages at the 5'-end of the sense strand, the antisense strand, or both strands. In another non-limiting

example, an exemplary siNA molecule of the invention can comprise one or more (*e.g.*, about 1, 2, 3, 4, 5, 6, 7, 8, 9, 10, or more) pyrimidine phosphorothioate internucleotide linkages in the sense strand, the antisense strand, or both strands. In yet another non-limiting example, an exemplary siNA molecule of the invention can comprise one or more (*e.g.*, about 1, 2, 3, 4, 5, 6, 7, 8, 9, 10, or more) purine phosphorothioate internucleotide linkages in the sense strand, the antisense strand, or both strands.

In one embodiment, the invention features a siNA molecule, wherein the sense strand comprises one or more, for example, about 1, 2, 3, 4, 5, 6, 7, 8, 9, 10, or more phosphorothioate internucleotide linkages, and/or one or more (*e.g.*, about 1, 2, 3, 4, 5, 6, 7, 8, 9, 10 or more) 2'-deoxy, 2'-O-methyl, 2'-deoxy-2'-fluoro, and/or about one or more (*e.g.*, about 1, 2, 3, 4, 5, 6, 7, 8, 9, 10 or more) universal base modified nucleotides, and optionally a terminal cap molecule at the 3'-end, the 5'-end, or both of the 3'- and 5'-ends of the sense strand; and wherein the antisense strand comprises about 1 to about 10 or more, specifically about 1, 2, 3, 4, 5, 6, 7, 8, 9, 10, or more phosphorothioate internucleotide linkages, and/or one or more (*e.g.*, about 1, 2, 3, 4, 5, 6, 7, 8, 9, 10 or more) 2'-deoxy, 2'-O-methyl, 2'-deoxy-2'-fluoro, and/or one or more (*e.g.*, about 1, 2, 3, 4, 5, 6, 7, 8, 9, 10 or more) universal base modified nucleotides, and optionally a terminal cap molecule at the 3'-end, the 5'-end, or both of the 3'- and 5'-ends of the antisense strand. In another embodiment, one or more, for example about 1, 2, 3, 4, 5, 6, 7, 8, 9, 10, or more, pyrimidine nucleotides of the sense and/or antisense siNA strand are chemically-modified with 2'-deoxy, 2'-O-methyl and/or 2'-deoxy-2'-fluoro nucleotides, with or without one or more, for example about 1, 2, 3, 4, 5, 6, 7, 8, 9, 10, or more, phosphorothioate internucleotide linkages and/or a terminal cap molecule at the 3'-end, the 5'-end, or both of the 3'- and 5'-ends, being present in the same or different strand.

In another embodiment, the invention features a siNA molecule, wherein the sense strand comprises about 1 to about 5, specifically about 1, 2, 3, 4, or 5 phosphorothioate internucleotide linkages, and/or one or more (*e.g.*, about 1, 2, 3, 4, 5, or more) 2'-deoxy, 2'-O-methyl, 2'-deoxy-2'-fluoro, and/or one or more (*e.g.*, about 1, 2, 3, 4, 5, or more) universal base modified nucleotides, and optionally a terminal cap molecule at the 3'-end, the 5'-end, or both of the 3'- and 5'-ends of the sense strand; and wherein the antisense strand comprises about 1 to about 5 or more, specifically about 1, 2, 3, 4, 5, or more phosphorothioate internucleotide linkages, and/or one or more (*e.g.*, about 1, 2, 3, 4, 5, 6, 7,

8, 9, 10 or more) 2'-deoxy, 2'-O-methyl, 2'-deoxy-2'-fluoro, and/or one or more (*e.g.*, about 1, 2, 3, 4, 5, 6, 7, 8, 9, 10 or more) universal base modified nucleotides, and optionally a terminal cap molecule at the 3'-end, the 5'-end, or both of the 3'- and 5'-ends of the antisense strand. In another embodiment, one or more, for example about 1, 2, 3, 4, 5, 6, 7, 8, 9, 10, 5 or more, pyrimidine nucleotides of the sense and/or antisense siNA strand are chemically-modified with 2'-deoxy, 2'-O-methyl and/or 2'-deoxy-2'-fluoro nucleotides, with or without about 1 to about 5 or more, for example about 1, 2, 3, 4, 5, or more phosphorothioate internucleotide linkages and/or a terminal cap molecule at the 3'-end, the 5'-end, or both of the 3'- and 5'-ends, being present in the same or different strand.

10 In one embodiment, the invention features a siNA molecule, wherein the antisense strand comprises one or more, for example, about 1, 2, 3, 4, 5, 6, 7, 8, 9, 10, or more phosphorothioate internucleotide linkages, and/or about one or more (*e.g.*, about 1, 2, 3, 4, 5, 6, 7, 8, 9, 10 or more) 2'-deoxy, 2'-O-methyl, 2'-deoxy-2'-fluoro, and/or one or more (*e.g.*, about 1, 2, 3, 4, 5, 6, 7, 8, 9, 10 or more) universal base modified nucleotides, and optionally a terminal cap molecule at the 3'-end, the 5'-end, or both of the 3'- and 5'-ends of the sense strand; and wherein the antisense strand comprises about 1 to about 10 or more, specifically about 1, 2, 3, 4, 5, 6, 7, 8, 9, 10 or more phosphorothioate internucleotide linkages, and/or one or more (*e.g.*, about 1, 2, 3, 4, 5, 6, 7, 8, 9, 10 or more) 2'-deoxy, 2'-O-methyl, 2'-deoxy-2'-fluoro, and/or one or more (*e.g.*, about 1, 2, 3, 4, 5, 6, 7, 8, 9, 10 or more) universal base modified nucleotides, and optionally a terminal cap molecule at the 3'-end, the 5'-end, or both of the 3'- and 5'-ends of the antisense strand. In another embodiment, one or more, for example about 1, 2, 3, 4, 5, 6, 7, 8, 9, 10 or more pyrimidine nucleotides of the sense and/or antisense siNA strand are chemically-modified with 2'-deoxy, 2'-O-methyl and/or 2'-deoxy-2'-fluoro nucleotides, with or without one or more, 20 for example, about 1, 2, 3, 4, 5, 6, 7, 8, 9, 10 or more phosphorothioate internucleotide linkages and/or a terminal cap molecule at the 3'-end, the 5'-end, or both of the 3' and 5'-ends, being present in the same or different strand.

In another embodiment, the invention features a siNA molecule, wherein the antisense strand comprises about 1 to about 5 or more, specifically about 1, 2, 3, 4, 5 or 30 more phosphorothioate internucleotide linkages, and/or one or more (*e.g.*, about 1, 2, 3, 4, 5, 6, 7, 8, 9, 10 or more) 2'-deoxy, 2'-O-methyl, 2'-deoxy-2'-fluoro, and/or one or more (*e.g.*, about 1, 2, 3, 4, 5, 6, 7, 8, 9, 10 or more) universal base modified nucleotides, and

optionally a terminal cap molecule at the 3'-end, the 5'-end, or both of the 3'- and 5'-ends of the sense strand; and wherein the antisense strand comprises about 1 to about 5 or more, specifically about 1, 2, 3, 4, 5 or more phosphorothioate internucleotide linkages, and/or one or more (*e.g.*, about 1, 2, 3, 4, 5, 6, 7, 8, 9, 10 or more) 2'-deoxy, 2'-O-methyl, 5 2'-deoxy-2'-fluoro, and/or one or more (*e.g.*, about 1, 2, 3, 4, 5, 6, 7, 8, 9, 10 or more) universal base modified nucleotides, and optionally a terminal cap molecule at the 3'-end, the 5'-end, or both of the 3'- and 5'-ends of the antisense strand. In another embodiment, one or more, for example about 1, 2, 3, 4, 5, 6, 7, 8, 9, 10 or more pyrimidine nucleotides of the sense and/or antisense siNA strand are chemically-modified with 2'-deoxy, 2'-O-methyl 10 and/or 2'-deoxy-2'-fluoro nucleotides, with or without about 1 to about 5, for example about 1, 2, 3, 4, 5 or more phosphorothioate internucleotide linkages and/or a terminal cap molecule at the 3'-end, the 5'-end, or both of the 3'- and 5'-ends, being present in the same or different strand.

In one embodiment, the invention features a chemically-modified short interfering 15 nucleic acid (siNA) molecule having about 1 to about 5, specifically about 1, 2, 3, 4, 5 or more phosphorothioate internucleotide linkages in each strand of the siNA molecule.

In another embodiment, the invention features a siNA molecule comprising 2'-5' 20 internucleotide linkages. The 2'-5' internucleotide linkage(s) can be at the 3'-end, the 5'-end, or both of the 3'- and 5'-ends of one or both siNA sequence strands. In addition, the 2'-5' internucleotide linkage(s) can be present at various other positions within one or both siNA sequence strands, for example, about 1, 2, 3, 4, 5, 6, 7, 8, 9, 10, or more including every internucleotide linkage of a pyrimidine nucleotide in one or both strands of the siNA molecule can comprise a 2'-5' internucleotide linkage, or about 1, 2, 3, 4, 5, 6, 7, 8, 9, 10, or 25 more including every internucleotide linkage of a purine nucleotide in one or both strands of the siNA molecule can comprise a 2'-5' internucleotide linkage.

In another embodiment, a chemically-modified siNA molecule of the invention 30 comprises a duplex having two strands, one or both of which can be chemically-modified, wherein each strand is about 18 to about 27 (*e.g.*, about 18, 19, 20, 21, 22, 23, 24, 25, 26, or 27) nucleotides in length, wherein the duplex has about 18 to about 23 (*e.g.*, about 18, 19, 20, 21, 22, or 23) base pairs, and wherein the chemical modification comprises a structure having any of Formulae I-VII. For example, an exemplary chemically-modified siNA

molecule of the invention comprises a duplex having two strands, one or both of which can be chemically-modified with a chemical modification having any of Formulae I-VII or any combination thereof, wherein each strand consists of about 21 nucleotides, each having a 2-nucleotide 3'-terminal nucleotide overhang, and wherein the duplex has about 19 base pairs. In another embodiment, a siNA molecule of the invention comprises a single stranded hairpin structure, wherein the siNA is about 36 to about 70 (*e.g.*, about 36, 40, 45, 50, 55, 60, 65, or 70) nucleotides in length having about 18 to about 23 (*e.g.*, about 18, 19, 20, 21, 22, or 23) base pairs, and wherein the siNA can include a chemical modification comprising a structure having any of Formulae I-VII or any combination thereof. For example, an exemplary chemically-modified siNA molecule of the invention comprises a linear oligonucleotide having about 42 to about 50 (*e.g.*, about 42, 43, 44, 45, 46, 47, 48, 49, or 50) nucleotides that is chemically-modified with a chemical modification having any of Formulae I-VII or any combination thereof, wherein the linear oligonucleotide forms a hairpin structure having about 19 base pairs and a 2-nucleotide 3'-terminal nucleotide overhang. In another embodiment, a linear hairpin siNA molecule of the invention contains a stem loop motif, wherein the loop portion of the siNA molecule is biodegradable. For example, a linear hairpin siNA molecule of the invention is designed such that degradation of the loop portion of the siNA molecule *in vivo* can generate a double-stranded siNA molecule with 3'-terminal overhangs, such as 3'-terminal nucleotide overhangs comprising about 2 nucleotides.

In another embodiment, a siNA molecule of the invention comprises a hairpin structure, wherein the siNA is about 25 to about 50 (*e.g.*, about 25, 26, 27, 28, 29, 30, 31, 32, 33, 34, 35, 36, 37, 38, 39, 40, 41, 42, 43, 44, 45, 46, 47, 48, 49, or 50) nucleotides in length having about 3 to about 25 (*e.g.*, about 3, 4, 5, 6, 7, 8, 9, 10, 11, 12, 13, 14, 15, 16, 17, 18, 19, 20, 21, 22, 23, 24, or 25) base pairs, and wherein the siNA can include one or more chemical modifications comprising a structure having any of Formulae I-VII or any combination thereof. For example, an exemplary chemically-modified siNA molecule of the invention comprises a linear oligonucleotide having about 25 to about 35 (*e.g.*, about 25, 26, 27, 28, 29, 30, 31, 32, 33, 34, or 35) nucleotides that is chemically-modified with one or more chemical modifications having any of Formulae I-VII or any combination thereof, wherein the linear oligonucleotide forms a hairpin structure having about 3 to about 23 (*e.g.*, about 3, 4, 5, 6, 7, 8, 9, 10, 11, 12, 13, 14, 15, 16, 17, 18, 19, 20, 21, 22, or 23) base pairs and

a 5'-terminal phosphate group that can be chemically modified as described herein (for example a 5'-terminal phosphate group having Formula IV). In another embodiment, a linear hairpin siNA molecule of the invention contains a stem loop motif, wherein the loop portion of the siNA molecule is biodegradable. In another embodiment, a linear hairpin  
5 siNA molecule of the invention comprises a loop portion comprising a non-nucleotide linker.

In another embodiment, a siNA molecule of the invention comprises an asymmetric hairpin structure, wherein the siNA is about 25 to about 50 (*e.g.*, about 25, 26, 27, 28, 29, 30, 31, 32, 33, 34, 35, 36, 37, 38, 39, 40, 41, 42, 43, 44, 45, 46, 47, 48, 49, or 50)  
10 nucleotides in length having about 3 to about 20 (*e.g.*, about 3, 4, 5, 6, 7, 8, 9, 10, 11, 12, 13, 14, 15, 16, 17, 18, 19, or 20) base pairs, and wherein the siNA can include one or more chemical modifications comprising a structure having any of Formulae I-VII or any combination thereof. For example, an exemplary chemically-modified siNA molecule of the invention comprises a linear oligonucleotide having about 25 to about 35 (*e.g.*, about 25,  
15 26, 27, 28, 29, 30, 31, 32, 33, 34, or 35) nucleotides that is chemically-modified with one or more chemical modifications having any of Formulae I-VII or any combination thereof, wherein the linear oligonucleotide forms an asymmetric hairpin structure having about 3 to about 18 (*e.g.*, about 3, 4, 5, 6, 7, 8, 9, 10, 11, 12, 13, 14, 15, 16, 17, or 18) base pairs and a  
20 5'-terminal phosphate group that can be chemically modified as described herein (for example a 5'-terminal phosphate group having Formula IV). In another embodiment, an asymmetric hairpin siNA molecule of the invention contains a stem loop motif, wherein the loop portion of the siNA molecule is biodegradable. In another embodiment, an asymmetric hairpin siNA molecule of the invention comprises a loop portion comprising a non-nucleotide linker.

25 In another embodiment, a siNA molecule of the invention comprises an asymmetric double stranded structure having separate polynucleotide strands comprising sense and antisense regions, wherein the antisense region is about 16 to about 25 (*e.g.*, about 16, 17, 18, 19, 20, 21, 22, 23, 24, or 25) nucleotides in length, wherein the sense region is about 3 to about 18 (*e.g.*, about 3, 4, 5, 6, 7, 8, 9, 10, 11, 12, 13, 14, 15, 16, 17, or 18) nucleotides in  
30 length, wherein the sense region the antisense region have at least 3 complementary nucleotides, and wherein the siNA can include one or more chemical modifications comprising a structure having any of Formulae I-VII or any combination thereof. For

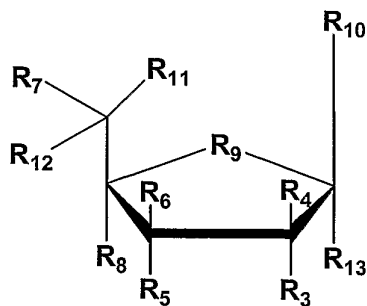
example, an exemplary chemically-modified siNA molecule of the invention comprises an asymmetric double stranded structure having separate polynucleotide strands comprising sense and antisense regions, wherein the antisense region is about 18 to about 22 (*e.g.*, about 18, 19, 20, 21, or 22) nucleotides in length and wherein the sense region is about 3 to  
5 about 15 (*e.g.*, about 3, 4, 5, 6, 7, 8, 9, 10, 11, 12, 13, 14, or 15) nucleotides in length, wherein the sense region the antisense region have at least 3 complementary nucleotides, and wherein the siNA can include one or more chemical modifications comprising a structure having any of Formulae I-VII or any combination thereof. In another embodiment, the asymmetric double stranded siNA molecule can also have a 5'-terminal  
10 phosphate group that can be chemically modified as described herein (for example a 5'-terminal phosphate group having Formula IV).

In another embodiment, a siNA molecule of the invention comprises a circular nucleic acid molecule, wherein the siNA is about 38 to about 70 (*e.g.*, about 38, 40, 45, 50, 55, 60, 65, or 70) nucleotides in length having about 18 to about 23 (*e.g.*, about 17, 18, 19,  
15 20, 21, 22, 23 or 24) base pairs, and wherein the siNA can include a chemical modification, which comprises a structure having any of Formulae I-VII or any combination thereof. For example, an exemplary chemically-modified siNA molecule of the invention comprises a circular oligonucleotide having about 42 to about 50 (*e.g.*, about 42, 43, 44, 45, 46, 47, 48, 49, or 50) nucleotides that is chemically-modified with a chemical modification having any  
20 of Formulae I-VII or any combination thereof, wherein the circular oligonucleotide forms a dumbbell shaped structure having about 19 base pairs and 2 loops.

In another embodiment, a circular siNA molecule of the invention contains two loop motifs, wherein one or both loop portions of the siNA molecule is biodegradable. For example, a circular siNA molecule of the invention is designed such that degradation of the  
25 loop portions of the siNA molecule *in vivo* can generate a double-stranded siNA molecule with 3'-terminal overhangs, such as 3'-terminal nucleotide overhangs comprising about 2 nucleotides.

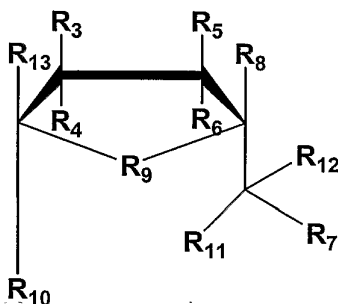
In one embodiment, a siNA molecule of the invention comprises at least one (*e.g.*, about 1, 2, 3, 4, 5, 6, 7, 8, 9, 10, or more) abasic moiety, for example a compound having  
30 Formula V:





wherein each R<sub>3</sub>, R<sub>4</sub>, R<sub>5</sub>, R<sub>6</sub>, R<sub>7</sub>, R<sub>8</sub>, R<sub>10</sub>, R<sub>11</sub>, R<sub>12</sub>, and R<sub>13</sub> is independently H, OH, alkyl, substituted alkyl, alkaryl or aralkyl, F, Cl, Br, CN, CF<sub>3</sub>, OCF<sub>3</sub>, OCN, O-alkyl, S-alkyl, N-alkyl, O-alkenyl, S-alkenyl, N-alkenyl, SO-alkyl, alkyl-OSH, alkyl-OH, O-alkyl-OH, O-alkyl-SH, S-alkyl-OH, S-alkyl-SH, alkyl-S-alkyl, alkyl-O-alkyl, ONO<sub>2</sub>, NO<sub>2</sub>, N<sub>3</sub>, NH<sub>2</sub>, aminoalkyl, aminoacid, aminoacyl, ONH<sub>2</sub>, O-aminoalkyl, O-aminoacid, O-aminoacyl, heterocycloalkyl, heterocycloalkaryl, aminoalkylamino, polyalkylamino, substituted silyl, or group having Formula I or II; R<sub>9</sub> is O, S, CH<sub>2</sub>, S=O, CHF, or CF<sub>2</sub>.

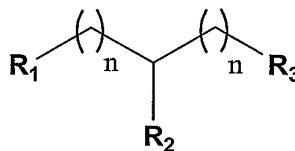
In one embodiment, a siNA molecule of the invention comprises at least one (*e.g.*, about 1, 2, 3, 4, 5, 6, 7, 8, 9, 10, or more) inverted abasic moiety, for example a compound having Formula VI:



wherein each R<sub>3</sub>, R<sub>4</sub>, R<sub>5</sub>, R<sub>6</sub>, R<sub>7</sub>, R<sub>8</sub>, R<sub>10</sub>, R<sub>11</sub>, R<sub>12</sub>, and R<sub>13</sub> is independently H, OH, alkyl, substituted alkyl, alkaryl or aralkyl, F, Cl, Br, CN, CF<sub>3</sub>, OCF<sub>3</sub>, OCN, O-alkyl, S-alkyl, N-alkyl, O-alkenyl, S-alkenyl, N-alkenyl, SO-alkyl, alkyl-OSH, alkyl-OH, O-alkyl-OH, O-alkyl-SH, S-alkyl-OH, S-alkyl-SH, alkyl-S-alkyl, alkyl-O-alkyl, ONO<sub>2</sub>, NO<sub>2</sub>, N<sub>3</sub>, NH<sub>2</sub>, aminoalkyl, aminoacid, aminoacyl, ONH<sub>2</sub>, O-aminoalkyl, O-aminoacid, O-aminoacyl, heterocycloalkyl, heterocycloalkaryl, aminoalkylamino, polyalkylamino, substituted silyl,

or group having Formula I or II; R<sub>9</sub> is O, S, CH<sub>2</sub>, S=O, CHF, or CF<sub>2</sub>, and either R<sub>3</sub>, R<sub>5</sub>, R<sub>8</sub> or R<sub>13</sub> serve as points of attachment to the siNA molecule of the invention.

In another embodiment, a siNA molecule of the invention comprises at least one (e.g., about 1, 2, 3, 4, 5, 6, 7, 8, 9, 10, or more) substituted polyalkyl moieties, for example a  
5 compound having Formula VII:



wherein each n is independently an integer from 1 to 12, each R<sub>1</sub>, R<sub>2</sub> and R<sub>3</sub> is independently H, OH, alkyl, substituted alkyl, alkaryl or aralkyl, F, Cl, Br, CN, CF<sub>3</sub>, OCF<sub>3</sub>, OCN, O-alkyl, S-alkyl, N-alkyl, O-alkenyl, S-alkenyl, N-alkenyl, SO-alkyl, alkyl-OSH,  
10 alkyl-OH, O-alkyl-OH, O-alkyl-SH, S-alkyl-OH, S-alkyl-SH, alkyl-S-alkyl, alkyl-O-alkyl, ONO<sub>2</sub>, NO<sub>2</sub>, N<sub>3</sub>, NH<sub>2</sub>, aminoalkyl, aminoacid, aminoacyl, ONH<sub>2</sub>, O-aminoalkyl, O-aminoacid, O-aminoacyl, heterocycloalkyl, heterocycloalkaryl, aminoalkylamino, polyalkylamino, substituted silyl, or a group having Formula I, and R<sub>1</sub>, R<sub>2</sub> or R<sub>3</sub> serves as points of attachment to the siNA molecule of the invention.

In another embodiment, the invention features a compound having Formula VII,  
15 wherein R<sub>1</sub> and R<sub>2</sub> are hydroxyl (OH) groups, n = 1, and R<sub>3</sub> comprises O and is the point of attachment to the 3'-end, the 5'-end, or both of the 3' and 5'-ends of one or both strands of a double-stranded siNA molecule of the invention or to a single-stranded siNA molecule of the invention. This modification is referred to herein as "glyceryl" (for example  
20 modification 6 in **Figure 22**).

In another embodiment, a moiety having any of Formula V, VI or VII of the invention is at the 3'-end, the 5'-end, or both of the 3' and 5'-ends of a siNA molecule of the invention. For example, a moiety having Formula V, VI or VII can be present at the 3'-end, the 5'-end, or both of the 3' and 5'-ends of the antisense strand, the sense strand, or both  
25 antisense and sense strands of the siNA molecule. In addition, a moiety having Formula VII can be present at the 3'-end or the 5'-end of a hairpin siNA molecule as described herein.

In another embodiment, a siNA molecule of the invention comprises an abasic residue having Formula V or VI, wherein the abasic residue having Formula V or VI is connected to the siNA construct in a 3-3', 3-2', 2-3', or 5-5' configuration, such as at the 3'-end, the 5'-end, or both of the 3' and 5'-ends of one or both siNA strands.

5 In one embodiment, a siNA molecule of the invention comprises one or more (*e.g.*, about 1, 2, 3, 4, 5, 6, 7, 8, 9, 10, or more) locked nucleic acid (LNA) nucleotides, for example at the 5'-end, the 3'-end, both of the 5' and 3'-ends, or any combination thereof, of the siNA molecule.

10 In another embodiment, a siNA molecule of the invention comprises one or more (*e.g.*, about 1, 2, 3, 4, 5, 6, 7, 8, 9, 10, or more) acyclic nucleotides, for example at the 5'-end, the 3'-end, both of the 5' and 3'-ends, or any combination thereof, of the siNA molecule.

In one embodiment, the sense strand of a double stranded siNA molecule of the invention comprises a terminal cap moiety, (see for example **Figure 22**) such as an inverted deoxyabasic moiety or inverted nucleotide, at the 3'-end, 5'-end, or both 3' and 5'-ends of  
15 the sense strand.

In one embodiment, the invention features a chemically-modified short interfering nucleic acid (siNA) molecule of the invention, wherein the chemically-modified siNA comprises a sense region, where any (*e.g.*, one or more or all) pyrimidine nucleotides present in the sense region are 2'-deoxy-2'-fluoro pyrimidine nucleotides (*e.g.*, wherein all  
20 pyrimidine nucleotides are 2'-deoxy-2'-fluoro pyrimidine nucleotides or alternately a plurality of pyrimidine nucleotides are 2'-deoxy-2'-fluoro pyrimidine nucleotides), and where any (*e.g.*, one or more or all) purine nucleotides present in the sense region are 2'-deoxy purine nucleotides (*e.g.*, wherein all purine nucleotides are 2'-deoxy purine nucleotides or alternately a plurality of purine nucleotides are 2'-deoxy purine nucleotides).

25 In one embodiment, the invention features a chemically-modified short interfering nucleic acid (siNA) molecule of the invention, wherein the chemically-modified siNA comprises a sense region, where any (*e.g.*, one or more or all) pyrimidine nucleotides present in the sense region are 2'-deoxy-2'-fluoro pyrimidine nucleotides (*e.g.*, wherein all pyrimidine nucleotides are 2'-deoxy-2'-fluoro pyrimidine nucleotides or alternately a  
30 plurality of pyrimidine nucleotides are 2'-deoxy-2'-fluoro pyrimidine nucleotides), and

where any (*e.g.*, one or more or all) purine nucleotides present in the sense region are 2'-deoxy purine nucleotides (*e.g.*, wherein all purine nucleotides are 2'-deoxy purine nucleotides or alternately a plurality of purine nucleotides are 2'-deoxy purine nucleotides), wherein any nucleotides comprising a 3'-terminal nucleotide overhang that are present in  
5 said sense region are 2'-deoxy nucleotides.

In one embodiment, the invention features a chemically-modified short interfering nucleic acid (siNA) molecule of the invention, wherein the chemically-modified siNA comprises a sense region, where any (*e.g.*, one or more or all) pyrimidine nucleotides present in the sense region are 2'-deoxy-2'-fluoro pyrimidine nucleotides (*e.g.*, wherein all  
10 pyrimidine nucleotides are 2'-deoxy-2'-fluoro pyrimidine nucleotides or alternately a plurality of pyrimidine nucleotides are 2'-deoxy-2'-fluoro pyrimidine nucleotides), and where any (*e.g.*, one or more or all) purine nucleotides present in the sense region are 2'-O-methyl purine nucleotides (*e.g.*, wherein all purine nucleotides are 2'-O-methyl purine nucleotides or alternately a plurality of purine nucleotides are 2'-O-methyl purine  
15 nucleotides).

In one embodiment, the invention features a chemically-modified short interfering nucleic acid (siNA) molecule of the invention, wherein the chemically-modified siNA comprises a sense region, where any (*e.g.*, one or more or all) pyrimidine nucleotides present in the sense region are 2'-deoxy-2'-fluoro pyrimidine nucleotides (*e.g.*, wherein all  
20 pyrimidine nucleotides are 2'-deoxy-2'-fluoro pyrimidine nucleotides or alternately a plurality of pyrimidine nucleotides are 2'-deoxy-2'-fluoro pyrimidine nucleotides), and where any (*e.g.*, one or more or all) purine nucleotides present in the sense region are 2'-O-methyl purine nucleotides (*e.g.*, wherein all purine nucleotides are 2'-O-methyl purine nucleotides or alternately a plurality of purine nucleotides are 2'-O-methyl purine  
25 nucleotides), wherein any nucleotides comprising a 3'-terminal nucleotide overhang that are present in said sense region are 2'-deoxy nucleotides.

In one embodiment, the invention features a chemically-modified short interfering nucleic acid (siNA) molecule of the invention, wherein the chemically-modified siNA comprises an antisense region, where any (*e.g.*, one or more or all) pyrimidine nucleotides present in the antisense region are 2'-deoxy-2'-fluoro pyrimidine nucleotides (*e.g.*, wherein all  
30 pyrimidine nucleotides are 2'-deoxy-2'-fluoro pyrimidine nucleotides or alternately a

plurality of pyrimidine nucleotides are 2'-deoxy-2'-fluoro pyrimidine nucleotides), and wherein any (*e.g.*, one or more or all) purine nucleotides present in the antisense region are 2'-O-methyl purine nucleotides (*e.g.*, wherein all purine nucleotides are 2'-O-methyl purine nucleotides or alternately a plurality of purine nucleotides are 2'-O-methyl purine  
5 nucleotides).

In one embodiment, the invention features a chemically-modified short interfering nucleic acid (siNA) molecule of the invention, wherein the chemically-modified siNA comprises an antisense region, where any (*e.g.*, one or more or all) pyrimidine nucleotides present in the antisense region are 2'-deoxy-2'-fluoro pyrimidine nucleotides (*e.g.*, wherein  
10 all pyrimidine nucleotides are 2'-deoxy-2'-fluoro pyrimidine nucleotides or alternately a plurality of pyrimidine nucleotides are 2'-deoxy-2'-fluoro pyrimidine nucleotides), and wherein any (*e.g.*, one or more or all) purine nucleotides present in the antisense region are 2'-O-methyl purine nucleotides (*e.g.*, wherein all purine nucleotides are 2'-O-methyl purine nucleotides or alternately a plurality of purine nucleotides are 2'-O-methyl purine  
15 nucleotides), wherein any nucleotides comprising a 3'-terminal nucleotide overhang that are present in said antisense region are 2'-deoxy nucleotides.

In one embodiment, the invention features a chemically-modified short interfering nucleic acid (siNA) molecule of the invention, wherein the chemically-modified siNA comprises an antisense region, where any (*e.g.*, one or more or all) pyrimidine nucleotides present in the antisense region are 2'-deoxy-2'-fluoro pyrimidine nucleotides (*e.g.*, wherein  
20 all pyrimidine nucleotides are 2'-deoxy-2'-fluoro pyrimidine nucleotides or alternately a plurality of pyrimidine nucleotides are 2'-deoxy-2'-fluoro pyrimidine nucleotides), and where any (*e.g.*, one or more or all) purine nucleotides present in the antisense region are 2'-deoxy purine nucleotides (*e.g.*, wherein all purine nucleotides are 2'-deoxy purine nucleotides or alternately a plurality of purine nucleotides are 2'-deoxy purine nucleotides).  
25

In one embodiment, the invention features a chemically-modified short interfering nucleic acid (siNA) molecule of the invention capable of mediating RNA interference (RNAi) inside a cell or reconstituted *in vitro* system comprising a sense region and an antisense region. In one embodiment, the sense region comprises one or more  
30 2'-deoxy-2'-fluoro pyrimidine nucleotides (*e.g.*, wherein all pyrimidine nucleotides are 2'-deoxy-2'-fluoro pyrimidine nucleotides or alternately a plurality of pyrimidine

nucleotides are 2'-deoxy-2'-fluoro pyrimidine nucleotides), and one or more 2'-deoxy purine nucleotides (*e.g.*, wherein all purine nucleotides are 2'-deoxy purine nucleotides or alternately a plurality of purine nucleotides are 2'-deoxy purine nucleotides). The sense region can comprise inverted deoxy abasic modifications that are optionally present at the 3'-end, the 5'-end, or both of the 3' and 5'-ends of the sense region. The sense region can optionally further comprise a 3'-terminal overhang having about 1 to about 4 (*e.g.*, about 1, 2, 3, or 4) 2'-deoxyribonucleotides. The antisense region comprises one or more 2'-deoxy-2'-fluoro pyrimidine nucleotides (*e.g.*, wherein all pyrimidine nucleotides are 2'-deoxy-2'-fluoro pyrimidine nucleotides or alternately a plurality of pyrimidine nucleotides are 2'-deoxy-2'-fluoro pyrimidine nucleotides), and one or more 2'-O-methyl purine nucleotides (*e.g.*, wherein all purine nucleotides are 2'-O-methyl purine nucleotides or alternately a plurality of purine nucleotides are 2'-O-methyl purine nucleotides). The antisense region can comprise a terminal cap modification, such as any modification described herein or shown in **Figure 22**, that is optionally present at the 3'-end, the 5'-end, or both of the 3' and 5'-ends of the antisense sequence. The antisense region optionally further comprises a 3'-terminal nucleotide overhang having about 1 to about 4 (*e.g.*, about 1, 2, 3, or 4) 2'-deoxynucleotides, wherein the overhang nucleotides can further comprise one or more (*e.g.*, 1, 2, 3, or 4 ) phosphorothioate internucleotide linkages. Non-limiting examples of these chemically-modified siNAs are shown in **Figures 18 and 19** and **Table IV** herein.

In another embodiment of the chemically-modified short interfering nucleic acid comprising a sense region and an antisense region, the sense region comprises one or more 2'-deoxy-2'-fluoro pyrimidine nucleotides (*e.g.*, wherein all pyrimidine nucleotides are 2'-deoxy-2'-fluoro pyrimidine nucleotides or alternately a plurality of pyrimidine nucleotides are 2'-deoxy-2'-fluoro pyrimidine nucleotides), and one or more purine ribonucleotides (*e.g.*, wherein all purine nucleotides are purine ribonucleotides or alternately a plurality of purine nucleotides are purine ribonucleotides). The sense region can also comprise inverted deoxy abasic modifications that are optionally present at the 3'-end, the 5'-end, or both of the 3' and 5'-ends of the sense region. The sense region optionally further comprises a 3'-terminal overhang having about 1 to about 4 (*e.g.*, about 1, 2, 3, or 4) 2'-deoxyribonucleotides. The antisense region comprises one or more 2'-deoxy-2'-fluoro pyrimidine nucleotides (*e.g.*, wherein all pyrimidine nucleotides are

2'-deoxy-2'-fluoro pyrimidine nucleotides or alternately a plurality of pyrimidine nucleotides are 2'-deoxy-2'-fluoro pyrimidine nucleotides), and one or more 2'-O-methyl purine nucleotides (e.g., wherein all purine nucleotides are 2'-O-methyl purine nucleotides or alternately a plurality of purine nucleotides are 2'-O-methyl purine nucleotides). The antisense region can also comprise a terminal cap modification, such as any modification described herein or shown in **Figure 22**, that is optionally present at the 3'-end, the 5'-end, or both of the 3' and 5'-ends of the antisense sequence. The antisense region optionally further comprises a 3'-terminal nucleotide overhang having about 1 to about 4 (e.g., about 1, 2, 3, or 4) 2'-deoxynucleotides, wherein the overhang nucleotides can further comprise one or more (e.g., 1, 2, 3, or 4) phosphorothioate internucleotide linkages. Non-limiting examples of these chemically-modified siNAs are shown in **Figures 18 and 19** and **Table IV** herein.

In another embodiment of the chemically-modified short interfering nucleic acid comprising a sense region and an antisense region, the sense region comprises one or more 2'-deoxy-2'-fluoro pyrimidine nucleotides (e.g., wherein all pyrimidine nucleotides are 2'-deoxy-2'-fluoro pyrimidine nucleotides or alternately a plurality of pyrimidine nucleotides are 2'-deoxy-2'-fluoro pyrimidine nucleotides), and one or more purine nucleotides selected from the group consisting of 2'-deoxy nucleotides, locked nucleic acid (LNA) nucleotides, 2'-methoxyethyl nucleotides, 4'-thionucleotides, and 2'-O-methyl nucleotides (e.g., wherein all purine nucleotides are selected from the group consisting of 2'-deoxy nucleotides, locked nucleic acid (LNA) nucleotides, 2'-methoxyethyl nucleotides, 4'-thionucleotides, and 2'-O-methyl nucleotides or alternately a plurality of purine nucleotides are selected from the group consisting of 2'-deoxy nucleotides, locked nucleic acid (LNA) nucleotides, 2'-methoxyethyl nucleotides, 4'-thionucleotides, and 2'-O-methyl nucleotides). The sense region can comprise inverted deoxy abasic modifications that are optionally present at the 3'-end, the 5'-end, or both of the 3' and 5'-ends of the sense region. The sense region can optionally further comprise a 3'-terminal overhang having about 1 to about 4 (e.g., about 1, 2, 3, or 4) 2'-deoxyribonucleotides. The antisense region comprises one or more 2'-deoxy-2'-fluoro pyrimidine nucleotides (e.g., wherein all pyrimidine nucleotides are 2'-deoxy-2'-fluoro pyrimidine nucleotides or alternately a plurality of pyrimidine nucleotides are 2'-deoxy-2'-fluoro pyrimidine nucleotides), and one or more purine nucleotides selected from the group consisting of 2'-deoxy nucleotides, locked

nucleic acid (LNA) nucleotides, 2'-methoxyethyl nucleotides, 4'-thionucleotides, and 2'-O-methyl nucleotides (e.g., wherein all purine nucleotides are selected from the group consisting of 2'-deoxy nucleotides, locked nucleic acid (LNA) nucleotides, 2'-methoxyethyl nucleotides, 4'-thionucleotides, and 2'-O-methyl nucleotides or alternately a plurality of purine nucleotides are selected from the group consisting of 2'-deoxy nucleotides, locked nucleic acid (LNA) nucleotides, 2'-methoxyethyl nucleotides, 4'-thionucleotides, and 2'-O-methyl nucleotides). The antisense can also comprise a terminal cap modification, such as any modification described herein or shown in **Figure 22**, that is optionally present at the 3'-end, the 5'-end, or both of the 3' and 5'-ends of the antisense sequence. The antisense region optionally further comprises a 3'-terminal nucleotide overhang having about 1 to about 4 (e.g., about 1, 2, 3, or 4) 2'-deoxynucleotides, wherein the overhang nucleotides can further comprise one or more (e.g., 1, 2, 3, or 4) phosphorothioate internucleotide linkages.

In another embodiment, any modified nucleotides present in the siNA molecules of the invention, preferably in the antisense strand of the siNA molecules of the invention, but also optionally in the sense and/or both antisense and sense strands, comprise modified nucleotides having properties or characteristics similar to naturally occurring ribonucleotides. For example, the invention features siNA molecules including modified nucleotides having a Northern conformation (e.g., Northern pseudorotation cycle, see for example Saenger, *Principles of Nucleic Acid Structure*, Springer-Verlag ed., 1984). As such, chemically modified nucleotides present in the siNA molecules of the invention, preferably in the antisense strand of the siNA molecules of the invention, but also optionally in the sense and/or both antisense and sense strands, are resistant to nuclease degradation while at the same time maintaining the capacity to mediate RNAi. Non-limiting examples of nucleotides having a northern configuration include locked nucleic acid (LNA) nucleotides (e.g., 2'-O,4'-C-methylene-(D-ribofuranosyl) nucleotides); 2'-methoxyethoxy (MOE) nucleotides; 2'-methyl-thio-ethyl, 2'-deoxy-2'-fluoro nucleotides, 2'-deoxy-2'-chloro nucleotides, 2'-azido nucleotides, and 2'-O-methyl nucleotides.

In one embodiment, the invention features a chemically-modified short interfering nucleic acid molecule (siNA) capable of mediating RNA interference (RNAi) inside a cell or reconstituted *in vitro* system, wherein the chemical modification comprises a conjugate



attached to the chemically-modified siNA molecule. The conjugate can be attached to the chemically-modified siNA molecule via a covalent attachment. In one embodiment, the conjugate is attached to the chemically-modified siNA molecule via a biodegradable linker. In one embodiment, the conjugate molecule is attached at the 3'-end of either the sense strand, the antisense strand, or both strands of the chemically-modified siNA molecule. In another embodiment, the conjugate molecule is attached at the 5'-end of either the sense strand, the antisense strand, or both strands of the chemically-modified siNA molecule. In yet another embodiment, the conjugate molecule is attached both the 3'-end and 5'-end of either the sense strand, the antisense strand, or both strands of the chemically-modified siNA molecule, or any combination thereof. In one embodiment, the conjugate molecule of the invention comprises a molecule that facilitates delivery of a chemically-modified siNA molecule into a biological system, such as a cell. In another embodiment, the conjugate molecule attached to the chemically-modified siNA molecule is a poly ethylene glycol, human serum albumin, or a ligand for a cellular receptor that can mediate cellular uptake. Examples of specific conjugate molecules contemplated by the instant invention that can be attached to chemically-modified siNA molecules are described in Vargeese *et al.*, U.S. Serial No. 10/201,394, incorporated by reference herein. The type of conjugates used and the extent of conjugation of siNA molecules of the invention can be evaluated for improved pharmacokinetic profiles, bioavailability, and/or stability of siNA constructs while at the same time maintaining the ability of the siNA to mediate RNAi activity. As such, one skilled in the art can screen siNA constructs that are modified with various conjugates to determine whether the siNA conjugate complex possesses improved properties while maintaining the ability to mediate RNAi, for example in animal models as are generally known in the art.

In one embodiment, the invention features a chemically-modified short interfering nucleic acid (siNA) molecule of the invention capable of mediating RNA interference (RNAi) inside a cell or reconstituted *in vitro* system, wherein the chemically-modified siNA comprises a sense region, where one or more pyrimidine nucleotides present in the sense region are 2'-deoxy-2'-fluoro pyrimidine nucleotides (*e.g.*, wherein all pyrimidine nucleotides are 2'-deoxy-2'-fluoro pyrimidine nucleotides or alternately a plurality of pyrimidine nucleotides are 2'-deoxy-2'-fluoro pyrimidine nucleotides), and where one or more purine nucleotides present in the sense region are 2'-deoxy purine nucleotides (*e.g.*,

wherein all purine nucleotides are 2'-deoxy purine nucleotides or alternately a plurality of purine nucleotides are 2'-deoxy purine nucleotides), and inverted deoxy abasic modifications that are optionally present at the 3'-end, the 5'-end, or both of the 3' and 5'-ends of the sense region, the sense region optionally further comprising a 3'-terminal overhang having about 1 to about 4 (e.g., about 1, 2, 3, or 4) 2'-deoxyribonucleotides; and wherein the chemically-modified short interfering nucleic acid molecule comprises an antisense region, where one or more pyrimidine nucleotides present in the antisense region are 2'-deoxy-2'-fluoro pyrimidine nucleotides (e.g., wherein all pyrimidine nucleotides are 2'-deoxy-2'-fluoro pyrimidine nucleotides or alternately a plurality of pyrimidine nucleotides are 2'-deoxy-2'-fluoro pyrimidine nucleotides), and wherein one or more purine nucleotides present in the antisense region are 2'-O-methyl purine nucleotides (e.g., wherein all purine nucleotides are 2'-O-methyl purine nucleotides or alternately a plurality of purine nucleotides are 2'-O-methyl purine nucleotides), and a terminal cap modification, such as any modification described herein or shown in **Figure 22**, that is optionally present at the 3'-end, the 5'-end, or both of the 3' and 5'-ends of the antisense sequence, the antisense region optionally further comprising a 3'-terminal nucleotide overhang having about 1 to about 4 (e.g., about 1, 2, 3, or 4) 2'-deoxynucleotides, wherein the overhang nucleotides can further comprise one or more (e.g., 1, 2, 3, or 4) phosphorothioate internucleotide linkages. Non-limiting examples of these chemically-modified siNAs are shown in **Figures 18 and 19** and **Table IV** herein.

In one embodiment, the invention features a chemically-modified short interfering nucleic acid (siNA) molecule of the invention capable of mediating RNA interference (RNAi) inside a cell or reconstituted *in vitro* system, wherein the chemically-modified siNA comprises a sense region, where one or more pyrimidine nucleotides present in the sense region are 2'-deoxy-2'-fluoro pyrimidine nucleotides (e.g., wherein all pyrimidine nucleotides are 2'-deoxy-2'-fluoro pyrimidine nucleotides or alternately a plurality of pyrimidine nucleotides are 2'-deoxy-2'-fluoro pyrimidine nucleotides), and where one or more purine nucleotides present in the sense region are 2'-O-methyl purine nucleotides (e.g., wherein all purine nucleotides are 2'-O-methyl purine nucleotides or alternately a plurality of purine nucleotides are 2'-O-methyl purine nucleotides), and inverted deoxy abasic modifications that are optionally present at the 3'-end, the 5'-end, or both of the 3' and 5'-ends of the sense region, the sense region optionally further comprising a 3'-terminal

overhang having about 1 to about 4 (e.g., about 1, 2, 3, or 4) 2'-deoxyribonucleotides; and wherein the chemically-modified short interfering nucleic acid molecule comprises an antisense region, where one or more pyrimidine nucleotides present in the antisense region are 2'-deoxy-2'-fluoro pyrimidine nucleotides (e.g., wherein all pyrimidine nucleotides are 2'-deoxy-2'-fluoro pyrimidine nucleotides or alternately a plurality of pyrimidine nucleotides are 2'-deoxy-2'-fluoro pyrimidine nucleotides), and wherein one or more purine nucleotides present in the antisense region are 2'-O-methyl purine nucleotides (e.g., wherein all purine nucleotides are 2'-O-methyl purine nucleotides or alternately a plurality of purine nucleotides are 2'-O-methyl purine nucleotides), and a terminal cap modification, such as any modification described herein or shown in **Figure 22**, that is optionally present at the 3'-end, the 5'-end, or both of the 3' and 5'-ends of the antisense sequence, the antisense region optionally further comprising a 3'-terminal nucleotide overhang having about 1 to about 4 (e.g., about 1, 2, 3, or 4) 2'-deoxynucleotides, wherein the overhang nucleotides can further comprise one or more (e.g., 1, 2, 3, or 4 ) phosphorothioate internucleotide linkages. Non-limiting examples of these chemically-modified siNAs are shown in **Figures 18 and 19** and **Table IV** herein.

In one embodiment, the invention features a chemically-modified short interfering nucleic acid (siNA) molecule of the invention capable of mediating RNA interference (RNAi) inside a cell or reconstituted *in vitro* system, wherein the siNA comprises a sense region, where one or more pyrimidine nucleotides present in the sense region are 2'-deoxy-2'-fluoro pyrimidine nucleotides (e.g., wherein all pyrimidine nucleotides are 2'-deoxy-2'-fluoro pyrimidine nucleotides or alternately a plurality of pyrimidine nucleotides are 2'-deoxy-2'-fluoro pyrimidine nucleotides), and where one or more purine nucleotides present in the sense region are purine ribonucleotides (e.g., wherein all purine nucleotides are purine ribonucleotides or alternately a plurality of purine nucleotides are purine ribonucleotides), and inverted deoxy abasic modifications that are optionally present at the 3'-end, the 5'-end, or both of the 3' and 5'-ends of the sense region, the sense region optionally further comprising a 3'-terminal overhang having about 1 to about 4 (e.g., about 1, 2, 3, or 4) 2'-deoxyribonucleotides; and wherein the siNA comprises an antisense region, where one or more pyrimidine nucleotides present in the antisense region are 2'-deoxy-2'-fluoro pyrimidine nucleotides (e.g., wherein all pyrimidine nucleotides are 2'-deoxy-2'-fluoro pyrimidine nucleotides or alternately a plurality of pyrimidine

nucleotides are 2'-deoxy-2'-fluoro pyrimidine nucleotides), and wherein any purine nucleotides present in the antisense region are 2'-O-methyl purine nucleotides (e.g., wherein all purine nucleotides are 2'-O-methyl purine nucleotides or alternately a plurality of purine nucleotides are 2'-O-methyl purine nucleotides), and a terminal cap modification, such as any modification described herein or shown in **Figure 22**, that is optionally present at the 3'-end, the 5'-end, or both of the 3' and 5'-ends of the antisense sequence, the antisense region optionally further comprising a 3'-terminal nucleotide overhang having about 1 to about 4 (e.g., about 1, 2, 3, or 4) 2'-deoxynucleotides, wherein the overhang nucleotides can further comprise one or more (e.g., 1, 2, 3, or 4) phosphorothioate internucleotide linkages. Non-limiting examples of these chemically-modified siNAs are shown in **Figures 18 and 19** and **Table IV** herein.

In one embodiment, the invention features a chemically-modified short interfering nucleic acid (siNA) molecule of the invention capable of mediating RNA interference (RNAi) inside a cell or reconstituted *in vitro* system, wherein the chemically-modified siNA comprises a sense region, where one or more pyrimidine nucleotides present in the sense region are 2'-deoxy-2'-fluoro pyrimidine nucleotides (e.g., wherein all pyrimidine nucleotides are 2'-deoxy-2'-fluoro pyrimidine nucleotides or alternately a plurality of pyrimidine nucleotides are 2'-deoxy-2'-fluoro pyrimidine nucleotides), and for example where one or more purine nucleotides present in the sense region are selected from the group consisting of 2'-deoxy nucleotides, locked nucleic acid (LNA) nucleotides, 2'-methoxyethyl nucleotides, 4'-thionucleotides, and 2'-O-methyl nucleotides (e.g., wherein all purine nucleotides are selected from the group consisting of 2'-deoxy nucleotides, locked nucleic acid (LNA) nucleotides, 2'-methoxyethyl nucleotides, 4'-thionucleotides, and 2'-O-methyl nucleotides or alternately a plurality of purine nucleotides are selected from the group consisting of 2'-deoxy nucleotides, locked nucleic acid (LNA) nucleotides, 2'-methoxyethyl nucleotides, 4'-thionucleotides, and 2'-O-methyl nucleotides), and wherein inverted deoxy abasic modifications are optionally present at the 3'-end, the 5'-end, or both of the 3' and 5'-ends of the sense region, the sense region optionally further comprising a 3'-terminal overhang having about 1 to about 4 (e.g., about 1, 2, 3, or 4) 2'-deoxyribonucleotides; and wherein the chemically-modified short interfering nucleic acid molecule comprises an antisense region, where one or more pyrimidine nucleotides present in the antisense region are 2'-deoxy-2'-fluoro pyrimidine

nucleotides (e.g., wherein all pyrimidine nucleotides are 2'-deoxy-2'-fluoro pyrimidine nucleotides or alternately a plurality of pyrimidine nucleotides are 2'-deoxy-2'-fluoro pyrimidine nucleotides), and wherein one or more purine nucleotides present in the antisense region are selected from the group consisting of 2'-deoxy nucleotides, locked nucleic acid (LNA) nucleotides, 2'-methoxyethyl nucleotides, 4'-thionucleotides, and 2'-O-methyl nucleotides (e.g., wherein all purine nucleotides are selected from the group consisting of 2'-deoxy nucleotides, locked nucleic acid (LNA) nucleotides, 2'-methoxyethyl nucleotides, 4'-thionucleotides, and 2'-O-methyl nucleotides or alternately a plurality of purine nucleotides are selected from the group consisting of 2'-deoxy nucleotides, locked nucleic acid (LNA) nucleotides, 2'-methoxyethyl nucleotides, 4'-thionucleotides, and 2'-O-methyl nucleotides), and a terminal cap modification, such as any modification described herein or shown in **Figure 22**, that is optionally present at the 3'-end, the 5'-end, or both of the 3' and 5'-ends of the antisense sequence, the antisense region optionally further comprising a 3'-terminal nucleotide overhang having about 1 to about 4 (e.g., about 1, 2, 3, or 4) 2'-deoxynucleotides, wherein the overhang nucleotides can further comprise one or more (e.g., 1, 2, 3, or 4) phosphorothioate internucleotide linkages.

In one embodiment, the invention features a short interfering nucleic acid (siNA) molecule of the invention, wherein the siNA further comprises a nucleotide, non-nucleotide, or mixed nucleotide/non-nucleotide linker that joins the sense region of the siNA to the antisense region of the siNA. In one embodiment, a nucleotide linker of the invention can be a linker of  $\geq 2$  nucleotides in length, for example 3, 4, 5, 6, 7, 8, 9, or 10 nucleotides in length. In another embodiment, the nucleotide linker can be a nucleic acid aptamer. By "aptamer" or "nucleic acid aptamer" as used herein is meant a nucleic acid molecule that binds specifically to a target molecule wherein the nucleic acid molecule has sequence that comprises a sequence recognized by the target molecule in its natural setting. Alternately, an aptamer can be a nucleic acid molecule that binds to a target molecule where the target molecule does not naturally bind to a nucleic acid. The target molecule can be any molecule of interest. For example, the aptamer can be used to bind to a ligand-binding domain of a protein, thereby preventing interaction of the naturally occurring ligand with the protein. This is a non-limiting example and those in the art will recognize that other embodiments can be readily generated using techniques generally known in the art (see, for example, Gold *et al.*, 1995, *Annu. Rev. Biochem.*, 64,

763; Brody and Gold, 2000, *J. Biotechnol.*, 74, 5; Sun, 2000, *Curr. Opin. Mol. Ther.*, 2, 100; Kusser, 2000, *J. Biotechnol.*, 74, 27; Hermann and Patel, 2000, *Science*, 287, 820; and Jayasena, 1999, *Clinical Chemistry*, 45, 1628.)

In yet another embodiment, a non-nucleotide linker of the invention comprises abasic  
5 nucleotide, polyether, polyamine, polyamide, peptide, carbohydrate, lipid, polyhydrocarbon, or other polymeric compounds (e.g., polyethylene glycols such as those having between 2 and 100 ethylene glycol units). Specific examples include those described by Seela and Kaiser, *Nucleic Acids Res.* 1990, 18:6353 and *Nucleic Acids Res.* 1987, 15:3113; Cload and Schepartz, *J. Am. Chem. Soc.* 1991, 113:6324; Richardson and  
10 Schepartz, *J. Am. Chem. Soc.* 1991, 113:5109; Ma *et al.*, *Nucleic Acids Res.* 1993, 21:2585 and *Biochemistry* 1993, 32:1751; Durand *et al.*, *Nucleic Acids Res.* 1990, 18:6353; McCurdy *et al.*, *Nucleosides & Nucleotides* 1991, 10:287; Jschke *et al.*, *Tetrahedron Lett.* 1993, 34:301; Ono *et al.*, *Biochemistry* 1991, 30:9914; Arnold *et al.*, International Publication No. WO 89/02439; Usman *et al.*, International Publication No. WO 95/06731;  
15 Dudycz *et al.*, International Publication No. WO 95/11910 and Ferentz and Verdine, *J. Am. Chem. Soc.* 1991, 113:4000, all hereby incorporated by reference herein. A "non-nucleotide" further means any group or compound that can be incorporated into a nucleic acid chain in the place of one or more nucleotide units, including either sugar and/or phosphate substitutions, and allows the remaining bases to exhibit their enzymatic  
20 activity. The group or compound can be abasic in that it does not contain a commonly recognized nucleotide base, such as adenosine, guanine, cytosine, uracil or thymine, for example at the C1 position of the sugar.

In one embodiment, the invention features a chemically-modified short interfering nucleic acid molecule (siNA) capable of mediating RNA interference (RNAi) against a  
25 target gene inside a cell or reconstituted *in vitro* system, wherein the chemical modification comprises a conjugate covalently attached to the chemically-modified siNA molecule. Non-limiting examples of conjugates contemplated by the invention include conjugates and ligands described in Vargeese *et al.*, USSN 10/427,160, filed April 30, 2003, incorporated by reference herein in its entirety, including the drawings. In another  
30 embodiment, the conjugate is covalently attached to the chemically-modified siNA molecule via a biodegradable linker. In one embodiment, the conjugate molecule is attached at the 3'-end of either the sense strand, the antisense strand, or both strands of the

chemically-modified siNA molecule. In another embodiment, the conjugate molecule is attached at the 5'-end of either the sense strand, the antisense strand, or both strands of the chemically-modified siNA molecule. In yet another embodiment, the conjugate molecule is attached both the 3'-end and 5'-end of either the sense strand, the antisense strand, or both strands of the chemically-modified siNA molecule, or any combination thereof. In one embodiment, a conjugate molecule of the invention comprises a molecule that facilitates delivery of a chemically-modified siNA molecule into a biological system, such as a cell. In another embodiment, the conjugate molecule attached to the chemically-modified siNA molecule is a polyethylene glycol, human serum albumin, or a ligand for a cellular receptor that can mediate cellular uptake. Examples of specific conjugate molecules contemplated by the instant invention that can be attached to chemically-modified siNA molecules are described in Vargeese *et al.*, U.S. Serial No. 10/201,394, incorporated by reference herein. The type of conjugates used and the extent of conjugation of siNA molecules of the invention can be evaluated for improved pharmacokinetic profiles, bioavailability, and/or stability of siNA constructs while at the same time maintaining the ability of the siNA to mediate RNAi activity. As such, one skilled in the art can screen siNA constructs that are modified with various conjugates to determine whether the siNA conjugate complex possesses improved properties while maintaining the ability to mediate RNAi, for example in animal models as are generally known in the art.

20 In one embodiment, the invention features a short interfering nucleic acid (siNA) molecule capable of mediating RNA interference (RNAi) inside a cell or reconstituted in vitro system, wherein one or both strands of the siNA molecule that are assembled from two separate oligonucleotides do not comprise any ribonucleotides. For example, a siNA molecule can be assembled from a single oligonucleotide where the sense and antisense regions of the siNA comprise separate oligonucleotides that do not have any ribonucleotides (e.g., nucleotides having a 2'-OH group) present in the oligonucleotides. In another example, a siNA molecule can be assembled from a single oligonucleotide where the sense and antisense regions of the siNA are linked or circularized by a nucleotide or non-nucleotide linker as described herein, wherein the oligonucleotide does not have any ribonucleotides (e.g., nucleotides having a 2'-OH group) present in the oligonucleotide. Applicant has surprisingly found that the presense of ribonucleotides (e.g., nucleotides having a 2'-hydroxyl group) within the siNA molecule is not required or essential to

support RNAi activity. As such, in one embodiment, all positions within the siNA can include chemically modified nucleotides and/or non-nucleotides such as nucleotides and or non-nucleotides having Formula I, II, III, IV, V, VI, or VII or any combination thereof to the extent that the ability of the siNA molecule to support RNAi activity in a cell is maintained.

In one embodiment, the invention features a siNA molecule that does not require the presence of a 2'-OH group (ribonucleotide) to be present withing the siNA molecule to support RNA interference.

In one embodiment, a siNA molecule of the invention is a single stranded siNA molecule that mediates RNAi activity in a cell or reconstituted in vitro system, wherein the siNA molecule comprises a single stranded polynucleotide having complementarity to a target nucleic acid sequence. In another embodiment, the single stranded siNA molecule of the invention comprises a 5'-terminal phosphate group. In another embodiment, the single stranded siNA molecule of the invention comprises a 5'-terminal phosphate group and a 3'-terminal phosphate group (e.g., a 2',3'-cyclic phosphate). In another embodiment, the single stranded siNA molecule of the invention comprises about 19 to about 29 (e.g., about 19, 20, 21, 22, 23, 24, 25, 26, 27, 28, or 29) nucleotides. In yet another embodiment, the single stranded siNA molecule of the invention comprises one or more chemically modified nucleotides or non-nucleotides described herein. For example, all the positions within the siNA molecule can include chemically-modified nucleotides such as nucleotides having any of Formulae I-VII, or any combination thereof to the extent that the ability of the siNA molecule to support RNAi activity in a cell is maintained.

In one embodiment, the single stranded siNA molecule having complementarity to a target nucleic acid sequence comprises one or more 2'-deoxy-2'-fluoro pyrimidine nucleotides (e.g., wherein all pyrimidine nucleotides are 2'-deoxy-2'-fluoro pyrimidine nucleotides or alternately a plurality of pyrimidine nucleotides are 2'-deoxy-2'-fluoro pyrimidine nucleotides), and one or more 2'-O-methyl purine nucleotides (e.g., wherein all purine nucleotides are 2'-O-methyl purine nucleotides or alternately a plurality of purine nucleotides are 2'-O-methyl purine nucleotides). In another embodiment, the single stranded siNA molecule comprises one or more 2'-deoxy-2'-fluoro pyrimidine nucleotides (e.g., wherein all pyrimidine nucleotides are 2'-deoxy-2'-fluoro pyrimidine nucleotides or



alternately a plurality of pyrimidine nucleotides are 2'-deoxy-2'-fluoro pyrimidine nucleotides), and one or more 2'-deoxy purine nucleotides (e.g., wherein all purine nucleotides are 2'-deoxy purine nucleotides or alternately a plurality of purine nucleotides are 2'-deoxy purine nucleotides). In another embodiment, the single stranded siNA molecule comprises one or more 2'-deoxy-2'-fluoro pyrimidine nucleotides (e.g., wherein all pyrimidine nucleotides are 2'-deoxy-2'-fluoro pyrimidine nucleotides or alternately a plurality of pyrimidine nucleotides are 2'-deoxy-2'-fluoro pyrimidine nucleotides), wherein any purine nucleotides present in the antisense region are locked nucleic acid (LNA) nucleotides (e.g., wherein all purine nucleotides are LNA nucleotides or alternately a plurality of purine nucleotides are LNA nucleotides). In another embodiment, the single stranded siNA molecule comprises one or more 2'-deoxy-2'-fluoro pyrimidine nucleotides (e.g., wherein all pyrimidine nucleotides are 2'-deoxy-2'-fluoro pyrimidine nucleotides or alternately a plurality of pyrimidine nucleotides are 2'-deoxy-2'-fluoro pyrimidine nucleotides), and one or more 2'-methoxyethyl purine nucleotides (e.g., wherein all purine nucleotides are 2'-methoxyethyl purine nucleotides or alternately a plurality of purine nucleotides are 2'-methoxyethyl purine nucleotides), the single stranded siNA can comprise a terminal cap modification, such as any modification described herein or shown in **Figure 22**, that is optionally present at the 3'-end, the 5'-end, or both of the 3' and 5'-ends of the antisense sequence. The single stranded siNA optionally further comprises about 1 to about 4 (e.g., about 1, 2, 3, or 4) terminal 2'-deoxynucleotides at the 3'-end of the siNA molecule, wherein the terminal nucleotides can further comprise one or more (e.g., 1, 2, 3, or 4) phosphorothioate internucleotide linkages. The single stranded siNA optionally further comprises a terminal phosphate group, such as a 5'-terminal phosphate group.

In one embodiment, a siNA molecule of the invention is a single stranded siNA molecule that mediates RNAi activity in a cell or reconstituted in vitro system, wherein the siNA molecule comprises a single stranded polynucleotide having complementarity to a target nucleic acid sequence, and wherein one or more pyrimidine nucleotides present in the siNA are 2'-deoxy-2'-fluoro pyrimidine nucleotides (e.g., wherein all pyrimidine nucleotides are 2'-deoxy-2'-fluoro pyrimidine nucleotides or alternately a plurality of pyrimidine nucleotides are 2'-deoxy-2'-fluoro pyrimidine nucleotides), and wherein any purine nucleotides present in the antisense region are 2'-O-methyl purine nucleotides (e.g., wherein all purine nucleotides are 2'-O-methyl purine nucleotides or alternately a plurality

of purine nucleotides are 2'-O-methyl purine nucleotides), and a terminal cap modification, such as any modification described herein or shown in **Figure 22**, that is optionally present at the 3'-end, the 5'-end, or both of the 3' and 5'-ends of the antisense sequence. The siNA optionally further comprises about 1 to about 4 or more (e.g., about 1, 2, 3, 4 or more) terminal 2'-deoxynucleotides at the 3'-end of the siNA molecule, wherein the terminal nucleotides can further comprise one or more (e.g., 1, 2, 3, 4 or more) phosphorothioate, phosphonoacetate, and/or thiophosphonoacetate internucleotide linkages, and wherein the siNA optionally further comprises a terminal phosphate group, such as a 5'-terminal phosphate group. In any of these embodiments, any purine nucleotides present in the antisense region are alternatively 2'-deoxy purine nucleotides (e.g., wherein all purine nucleotides are 2'-deoxy purine nucleotides or alternately a plurality of purine nucleotides are 2'-deoxy purine nucleotides). Also, in any of these embodiments, any purine nucleotides present in the siNA (i.e., purine nucleotides present in the sense and/or antisense region) can alternatively be locked nucleic acid (LNA) nucleotides (e.g., wherein all purine nucleotides are LNA nucleotides or alternately a plurality of purine nucleotides are LNA nucleotides). Also, in any of these embodiments, any purine nucleotides present in the siNA are alternatively 2'-methoxyethyl purine nucleotides (e.g., wherein all purine nucleotides are 2'-methoxyethyl purine nucleotides or alternately a plurality of purine nucleotides are 2'-methoxyethyl purine nucleotides). In another embodiment, any modified nucleotides present in the single stranded siNA molecules of the invention comprise modified nucleotides having properties or characteristics similar to naturally occurring ribonucleotides. For example, the invention features siNA molecules including modified nucleotides having a Northern conformation (e.g., Northern pseudorotation cycle, see for example Saenger, *Principles of Nucleic Acid Structure*, Springer-Verlag ed., 1984). As such, chemically modified nucleotides present in the single stranded siNA molecules of the invention are preferably resistant to nuclease degradation while at the same time maintaining the capacity to mediate RNAi

In one embodiment, a siNA molecule of the invention is a single stranded siNA molecule that mediates RNAi activity in a cell or reconstituted in vitro system, wherein the siNA molecule comprises a single stranded polynucleotide having complementarity to a target nucleic acid sequence, and wherein one or more pyrimidine nucleotides present in the siNA are 2'-deoxy-2'-fluoro pyrimidine nucleotides (e.g., wherein all pyrimidine

nucleotides are 2'-deoxy-2'-fluoro pyrimidine nucleotides or alternately a plurality of pyrimidine nucleotides are 2'-deoxy-2'-fluoro pyrimidine nucleotides), and wherein any purine nucleotides present in the siNA are 2'-O-methyl purine nucleotides (e.g., wherein all purine nucleotides are 2'-O-methyl purine nucleotides or alternately a plurality of purine nucleotides are 2'-O-methyl purine nucleotides), and a terminal cap modification, such as any modification described herein or shown in **Figure 22**, that is optionally present at the 3'-end, the 5'-end, or both of the 3' and 5'-ends of the antisense sequence, the siNA optionally further comprising about 1 to about 4 (e.g., about 1, 2, 3, or 4) terminal 2'-deoxynucleotides at the 3'-end of the siNA molecule, wherein the terminal nucleotides can further comprise one or more (e.g., 1, 2, 3, or 4 ) phosphorothioate internucleotide linkages, and wherein the siNA optionally further comprises a terminal phosphate group, such as a 5'-terminal phosphate group.

In one embodiment, a siNA molecule of the invention is a single stranded siNA molecule that mediates RNAi activity in a cell or reconstituted in vitro system, wherein the siNA molecule comprises a single stranded polynucleotide having complementarity to a target nucleic acid sequence, and wherein one or more pyrimidine nucleotides present in the siNA are 2'-deoxy-2'-fluoro pyrimidine nucleotides (e.g., wherein all pyrimidine nucleotides are 2'-deoxy-2'-fluoro pyrimidine nucleotides or alternately a plurality of pyrimidine nucleotides are 2'-deoxy-2'-fluoro pyrimidine nucleotides), and wherein any purine nucleotides present in the siNA are 2'-deoxy purine nucleotides (e.g., wherein all purine nucleotides are 2'-deoxy purine nucleotides or alternately a plurality of purine nucleotides are 2'-deoxy purine nucleotides), and a terminal cap modification, such as any modification described herein or shown in **Figure 22**, that is optionally present at the 3'-end, the 5'-end, or both of the 3' and 5'-ends of the antisense sequence, the siNA optionally further comprising about 1 to about 4 (e.g., about 1, 2, 3, or 4) terminal 2'-deoxynucleotides at the 3'-end of the siNA molecule, wherein the terminal nucleotides can further comprise one or more (e.g., 1, 2, 3, or 4 ) phosphorothioate internucleotide linkages, and wherein the siNA optionally further comprises a terminal phosphate group, such as a 5'-terminal phosphate group.

In one embodiment, a siNA molecule of the invention is a single stranded siNA molecule that mediates RNAi activity in a cell or reconstituted in vitro system, wherein the siNA molecule comprises a single stranded polynucleotide having complementarity to a

target nucleic acid sequence, and wherein one or more pyrimidine nucleotides present in the siNA are 2'-deoxy-2'-fluoro pyrimidine nucleotides (e.g., wherein all pyrimidine nucleotides are 2'-deoxy-2'-fluoro pyrimidine nucleotides or alternately a plurality of pyrimidine nucleotides are 2'-deoxy-2'-fluoro pyrimidine nucleotides), and wherein any  
5 purine nucleotides present in the siNA are locked nucleic acid (LNA) nucleotides (e.g., wherein all purine nucleotides are LNA nucleotides or alternately a plurality of purine nucleotides are LNA nucleotides), and a terminal cap modification, such as any modification described herein or shown in **Figure 22**, that is optionally present at the 3'-end, the 5'-end, or both of the 3' and 5'-ends of the antisense sequence, the siNA optionally  
10 further comprising about 1 to about 4 (e.g., about 1, 2, 3, or 4) terminal 2'-deoxynucleotides at the 3'-end of the siNA molecule, wherein the terminal nucleotides can further comprise one or more (e.g., 1, 2, 3, or 4 ) phosphorothioate internucleotide linkages, and wherein the siNA optionally further comprises a terminal phosphate group, such as a 5'-terminal phosphate group.

15 In one embodiment, a siNA molecule of the invention is a single stranded siNA molecule that mediates RNAi activity in a cell or reconstituted in vitro system, wherein the siNA molecule comprises a single stranded polynucleotide having complementarity to a target nucleic acid sequence, and wherein one or more pyrimidine nucleotides present in the siNA are 2'-deoxy-2'-fluoro pyrimidine nucleotides (e.g., wherein all pyrimidine  
20 nucleotides are 2'-deoxy-2'-fluoro pyrimidine nucleotides or alternately a plurality of pyrimidine nucleotides are 2'-deoxy-2'-fluoro pyrimidine nucleotides), and wherein any purine nucleotides present in the siNA are 2'-methoxyethyl purine nucleotides (e.g., wherein all purine nucleotides are 2'-methoxyethyl purine nucleotides or alternately a plurality of purine nucleotides are 2'-methoxyethyl purine nucleotides), and a terminal cap  
25 modification, such as any modification described herein or shown in **Figure 22**, that is optionally present at the 3'-end, the 5'-end, or both of the 3' and 5'-ends of the antisense sequence, the siNA optionally further comprising about 1 to about 4 (e.g., about 1, 2, 3, or 4) terminal 2'-deoxynucleotides at the 3'-end of the siNA molecule, wherein the terminal nucleotides can further comprise one or more (e.g., 1, 2, 3, or 4 ) phosphorothioate  
30 internucleotide linkages, and wherein the siNA optionally further comprises a terminal phosphate group, such as a 5'-terminal phosphate group.

In another embodiment, any modified nucleotides present in the single stranded siNA molecules of the invention comprise modified nucleotides having properties or characteristics similar to naturally occurring ribonucleotides. For example, the invention features siNA molecules including modified nucleotides having a Northern conformation  
5 (e.g., Northern pseudorotation cycle, see for example Saenger, *Principles of Nucleic Acid Structure*, Springer-Verlag ed., 1984). As such, chemically modified nucleotides present in the single stranded siNA molecules of the invention are preferably resistant to nuclease degradation while at the same time maintaining the capacity to mediate RNAi.

In one embodiment, the invention features a method for modulating the expression of  
10 a gene within a cell comprising: (a) synthesizing a siNA molecule of the invention, which can be chemically-modified, wherein one of the siNA strands comprises a sequence complementary to RNA of the gene; and (b) introducing the siNA molecule into a cell under conditions suitable to modulate the expression of the gene in the cell.

In one embodiment, the invention features a method for modulating the expression of  
15 a gene within a cell comprising: (a) synthesizing a siNA molecule of the invention, which can be chemically-modified, wherein one of the siNA strands comprises a sequence complementary to RNA of the gene and wherein the sense strand sequence of the siNA comprises a sequence substantially similar to the sequence of the target RNA; and (b) introducing the siNA molecule into a cell under conditions suitable to modulate the  
20 expression of the gene in the cell.

In another embodiment, the invention features a method for modulating the expression of more than one gene within a cell comprising: (a) synthesizing siNA molecules of the invention, which can be chemically-modified, wherein one of the siNA  
25 strands comprises a sequence complementary to RNA of the genes; and (b) introducing the siNA molecules into a cell under conditions suitable to modulate the expression of the genes in the cell.

In another embodiment, the invention features a method for modulating the expression of more than one gene within a cell comprising: (a) synthesizing a siNA molecule of the invention, which can be chemically-modified, wherein one of the siNA  
30 strands comprises a sequence complementary to RNA of the gene and wherein the sense strand sequence of the siNA comprises a sequence substantially similar to the sequence of

the target RNA; and (b) introducing the siNA molecules into a cell under conditions suitable to modulate the expression of the genes in the cell.

In one embodiment, siNA molecules of the invention are used as reagents in ex vivo applications. For example, siNA reagents are introduced into tissue or cells that are transplanted into a subject for therapeutic effect. The cells and/or tissue can be derived from an organism or subject that later receives the explant, or can be derived from another organism or subject prior to transplantation. The siNA molecules can be used to modulate the expression of one or more genes in the cells or tissue, such that the cells or tissue obtain a desired phenotype or are able to perform a function when transplanted in vivo. In one embodiment, certain target cells from a patient are extracted. These extracted cells are contacted with siNAs targeting a specific nucleotide sequence within the cells under conditions suitable for uptake of the siNAs by these cells (e.g., using delivery reagents such as cationic lipids, liposomes and the like or using techniques such as electroporation to facilitate the delivery of siNAs into cells). The cells are then reintroduced back into the same patient or other patients. Non-limiting examples of ex vivo applications include use in organ/tissue transplant, tissue grafting, or treatment of pulmonary disease (e.g., restenosis) or prevent neointimal hyperplasia and atherosclerosis in vein grafts. Such ex vivo applications may also be used to treat conditions associated with coronary and peripheral bypass graft failure, for example, such methods can be used in conjunction with peripheral vascular bypass graft surgery and coronary artery bypass graft surgery. Additional applications include transplants to treat CNS lesions or injury, including use in treatment of neurodegenerative conditions such as Alzheimer's disease, Parkinson's Disease, Epilepsy, Dementia, Huntington's disease, or amyotrophic lateral sclerosis (ALS).

In one embodiment, the invention features a method of modulating the expression of a gene in a tissue explant comprising: (a) synthesizing a siNA molecule of the invention, which can be chemically-modified, wherein one of the siNA strands comprises a sequence complementary to RNA of the gene; and (b) introducing the siNA molecule into a cell of the tissue explant derived from a particular organism under conditions suitable to modulate the expression of the gene in the tissue explant. In another embodiment, the method further comprises introducing the tissue explant back into the organism the tissue was derived from or into another organism under conditions suitable to modulate the expression of the gene in that organism.

In one embodiment, the invention features a method of modulating the expression of a gene in a tissue explant comprising: (a) synthesizing a siNA molecule of the invention, which can be chemically-modified, wherein one of the siNA strands comprises a sequence complementary to RNA of the gene and wherein the sense strand sequence of the siNA  
5 comprises a sequence substantially similar to the sequence of the target RNA; and (b) introducing the siNA molecule into a cell of the tissue explant derived from a particular organism under conditions suitable to modulate the expression of the gene in the tissue explant. In another embodiment, the method further comprises introducing the tissue explant back into the organism the tissue was derived from or into another organism under  
10 conditions suitable to modulate the expression of the gene in that organism.

In another embodiment, the invention features a method of modulating the expression of more than one gene in a tissue explant comprising: (a) synthesizing siNA molecules of the invention, which can be chemically-modified, wherein one of the siNA strands comprises a sequence complementary to RNA of the genes; and (b) introducing the  
15 siNA molecules into a cell of the tissue explant derived from a particular organism under conditions suitable to modulate the expression of the genes in the tissue explant. In another embodiment, the method further comprises introducing the tissue explant back into the organism the tissue was derived from or into another organism under conditions suitable to modulate the expression of the genes in that organism.

20 In one embodiment, the invention features a method of modulating the expression of a gene in an organism comprising: (a) synthesizing a siNA molecule of the invention, which can be chemically-modified, wherein one of the siNA strands comprises a sequence complementary to RNA of the gene; and (b) introducing the siNA molecule into the organism under conditions suitable to modulate the expression of the gene in the organism.

25 In another embodiment, the invention features a method of modulating the expression of more than one gene in an organism comprising: (a) synthesizing siNA molecules of the invention, which can be chemically-modified, wherein one of the siNA strands comprises a sequence complementary to RNA of the genes; and (b) introducing the siNA molecules into the organism under conditions suitable to modulate the expression of  
30 the genes in the organism.

In one embodiment, the invention features a method for modulating the expression of a gene within a cell comprising: (a) synthesizing a siNA molecule of the invention, which can be chemically-modified, wherein the siNA comprises a single stranded sequence having complementarity to RNA of the gene; and (b) introducing the siNA molecule into a cell under conditions suitable to modulate the expression of the gene in the cell.

In one embodiment, the invention features a method of modulating the expression of a target gene in an tissue or organ comprising: (a) synthesizing a siNA molecule of the invention, which can be chemically-modified, wherein the siNA comprises a single stranded sequence having complementarity to RNA of the target gene; and (b) introducing the siNA molecule into the tissue or organ under conditions suitable to modulate the expression of the target gene in the organism. In another embodiment, the tissue is ocular tissue and the organ is the eye. In another embodiment, the tissue comprises hepatocytes and/or hepatic tissue and the organ is the liver.

In another embodiment, the invention features a method for modulating the expression of more than one gene within a cell comprising: (a) synthesizing siNA molecules of the invention, which can be chemically-modified, wherein the siNA comprises a single stranded sequence having complementarity to RNA of the gene; and (b) contacting the siNA molecule with a cell in vitro or in vivo under conditions suitable to modulate the expression of the genes in the cell.

In one embodiment, the invention features a method of modulating the expression of a gene in a tissue explant comprising: (a) synthesizing a siNA molecule of the invention, which can be chemically-modified, wherein the siNA comprises a single stranded sequence having complementarity to RNA of the gene; and (b) contacting the siNA molecule with a cell of the tissue explant derived from a particular organism under conditions suitable to modulate the expression of the gene in the tissue explant. In another embodiment, the method further comprises introducing the tissue explant back into the organism the tissue was derived from or into another organism under conditions suitable to modulate the expression of the gene in that organism.

In another embodiment, the invention features a method of modulating the expression of more than one gene in a tissue explant comprising: (a) synthesizing siNA molecules of the invention, which can be chemically-modified, wherein the siNA



comprises a single stranded sequence having complementarity to RNA of the gene; and (b) introducing the siNA molecules into a cell of the tissue explant derived from a particular organism under conditions suitable to modulate the expression of the genes in the tissue explant. In another embodiment, the method further comprises introducing the tissue  
5 explant back into the organism the tissue was derived from or into another organism under conditions suitable to modulate the expression of the genes in that organism.

In one embodiment, the invention features a method of modulating the expression of a gene in an organism comprising: (a) synthesizing a siNA molecule of the invention, which can be chemically-modified, wherein the siNA comprises a single stranded sequence  
10 having complementarity to RNA of the gene; and (b) introducing the siNA molecule into the organism under conditions suitable to modulate the expression of the gene in the organism.

In another embodiment, the invention features a method of modulating the expression of more than one gene in an organism comprising: (a) synthesizing siNA  
15 molecules of the invention, which can be chemically-modified, wherein the siNA comprises a single stranded sequence having complementarity to RNA of the gene; and (b) introducing the siNA molecules into the organism under conditions suitable to modulate the expression of the genes in the organism.

In one embodiment, the invention features a method of modulating the expression of  
20 a gene in an organism comprising contacting the organism with a siNA molecule of the invention under conditions suitable to modulate the expression of the gene in the organism.

In another embodiment, the invention features a method of modulating the expression of more than one gene in an organism comprising contacting the organism with one or more siNA molecules of the invention under conditions suitable to modulate the  
25 expression of the genes in the organism.

The siNA molecules of the invention can be designed to down regulate or inhibit target gene expression through RNAi targeting of a variety of RNA molecules. In one embodiment, the siNA molecules of the invention are used to target various RNAs corresponding to a target gene. Non-limiting examples of such RNAs include messenger  
30 RNA (mRNA), alternate RNA splice variants of target gene(s), post-transcriptionally

modified RNA of target gene(s), pre-mRNA of target gene(s), and/or RNA templates. If alternate splicing produces a family of transcripts that are distinguished by usage of appropriate exons, the instant invention can be used to inhibit gene expression through the appropriate exons to specifically inhibit or to distinguish among the functions of gene family members. For example, a protein that contains an alternatively spliced transmembrane domain can be expressed in both membrane bound and secreted forms. Use of the invention to target the exon containing the transmembrane domain can be used to determine the functional consequences of pharmaceutical targeting of membrane bound as opposed to the secreted form of the protein. Non-limiting examples of applications of the invention relating to targeting these RNA molecules include therapeutic pharmaceutical applications, pharmaceutical discovery applications, molecular diagnostic and gene function applications, and gene mapping, for example using single nucleotide polymorphism mapping with siNA molecules of the invention. Such applications can be implemented using known gene sequences or from partial sequences available from an expressed sequence tag (EST).

In another embodiment, the siNA molecules of the invention are used to target conserved sequences corresponding to a gene family or gene families. As such, siNA molecules targeting multiple gene targets can provide increased therapeutic effect. In addition, siNA can be used to characterize pathways of gene function in a variety of applications. For example, the present invention can be used to inhibit the activity of target gene(s) in a pathway to determine the function of uncharacterized gene(s) in gene function analysis, mRNA function analysis, or translational analysis. The invention can be used to determine potential target gene pathways involved in various diseases and conditions toward pharmaceutical development. The invention can be used to understand pathways of gene expression involved in, for example, in development, such as prenatal development and postnatal development, and/or the progression and/or maintenance of cancer, infectious disease, autoimmunity, inflammation, endocrine disorders, renal disease, pulmonary disease, cardiovascular disease, birth defects, ageing, hair growth, any other disease, condition, trait, genotype or phenotype related to gene expression.

In one embodiment, siNA molecule(s) and/or methods of the invention are used to down-regulate or inhibit the expression of gene(s) that encode RNA referred to by Genbank

Accession, for example genes encoding RNA sequence(s) referred to herein by Genbank Accession number.

In one embodiment, the invention features a method comprising: (a) generating a library of siNA constructs having a predetermined complexity; and (b) assaying the siNA  
5 constructs of (a) above, under conditions suitable to determine RNAi target sites within the target RNA sequence. In one embodiment, the siNA molecules of (a) have strands of a fixed length, for example, about 23 nucleotides in length. In another embodiment, the siNA molecules of (a) are of differing length, for example having strands of about 19 to about 25 (*e.g.*, about 19, 20, 21, 22, 23, 24, or 25) nucleotides in length. In one  
10 embodiment, the assay can comprise a reconstituted *in vitro* siNA assay as described herein. In another embodiment, the assay can comprise a cell culture system in which target RNA is expressed. In another embodiment, fragments of target RNA are analyzed for detectable levels of cleavage, for example by gel electrophoresis, northern blot analysis, or RNase protection assays, to determine the most suitable target site(s) within the target RNA  
15 sequence. The target RNA sequence can be obtained as is known in the art, for example, by cloning and/or transcription for *in vitro* systems, and by cellular expression in *in vivo* systems.

In one embodiment, the invention features a method comprising: (a) generating a randomized library of siNA constructs having a predetermined complexity, such as of  $4^N$ ,  
20 where N represents the number of base paired nucleotides in each of the siNA construct strands (*eg.* for a siNA construct having 21 nucleotide sense and antisense strands with 19 base pairs, the complexity would be  $4^{19}$ ); and (b) assaying the siNA constructs of (a) above, under conditions suitable to determine RNAi target sites within the target RNA sequence.  
... In another embodiment, the siNA molecules of (a) have strands of a fixed length, for  
25 example about 23 nucleotides in length. In yet another embodiment, the siNA molecules of (a) are of differing length, for example having strands of about 19 to about 25 (*e.g.*, about 19, 20, 21, 22, 23, 24, or 25) nucleotides in length. In one embodiment, the assay can comprise a reconstituted *in vitro* siNA assay as described in Example 7 herein. In another  
30 embodiment, the assay can comprise a cell culture system in which target RNA is expressed. In another embodiment, fragments of target RNA are analyzed for detectable levels of cleavage, for example by gel electrophoresis, northern blot analysis, or RNase protection assays, to determine the most suitable target site(s) within the target RNA

sequence. In another embodiment, the target RNA sequence can be obtained as is known in the art, for example, by cloning and/or transcription for *in vitro* systems, and by cellular expression in *in vivo* systems.

In another embodiment, the invention features a method comprising: (a) analyzing  
5 the sequence of a RNA target encoded by a target gene; (b) synthesizing one or more sets of  
siNA molecules having sequence complementary to one or more regions of the RNA of (a);  
and (c) assaying the siNA molecules of (b) under conditions suitable to determine RNAi  
targets within the target RNA sequence. In one embodiment, the siNA molecules of (b)  
have strands of a fixed length, for example about 23 nucleotides in length. In another  
10 embodiment, the siNA molecules of (b) are of differing length, for example having strands  
of about 19 to about 25 (*e.g.*, about 19, 20, 21, 22, 23, 24, or 25) nucleotides in length. In  
one embodiment, the assay can comprise a reconstituted *in vitro* siNA assay as described  
herein. In another embodiment, the assay can comprise a cell culture system in which  
target RNA is expressed. Fragments of target RNA are analyzed for detectable levels of  
15 cleavage, for example by gel electrophoresis, northern blot analysis, or RNase protection  
assays, to determine the most suitable target site(s) within the target RNA sequence. The  
target RNA sequence can be obtained as is known in the art, for example, by cloning and/or  
transcription for *in vitro* systems, and by expression in *in vivo* systems.

By "target site" is meant a sequence within a target RNA that is "targeted" for  
20 cleavage mediated by a siNA construct which contains sequences within its antisense  
region that are complementary to the target sequence.

By "detectable level of cleavage" is meant cleavage of target RNA (and formation of  
cleaved product RNAs) to an extent sufficient to discern cleavage products above the  
background of RNAs produced by random degradation of the target RNA. Production of  
25 cleavage products from 1-5% of the target RNA is sufficient to detect above the  
background for most methods of detection.

In one embodiment, the invention features a composition comprising a siNA  
molecule of the invention, which can be chemically-modified, in a pharmaceutically  
acceptable carrier or diluent. In another embodiment, the invention features a  
30 pharmaceutical composition comprising siNA molecules of the invention, which can be  
chemically-modified, targeting one or more genes in a pharmaceutically acceptable carrier

or diluent. In another embodiment, the invention features a method for diagnosing a disease, condition, trait, genotype or phenotype in a subject comprising administering to the subject a composition of the invention under conditions suitable for the diagnosis of the disease, condition, trait, genotype or phenotype in the subject.

5           In one embodiment, the invention features a method for treating or preventing a disease, condition, trait, genotype or phenotype in a subject, comprising administering to the subject a composition of the invention under conditions suitable for the treatment or prevention of the disease, condition, trait, genotype or phenotype in the subject, alone or in conjunction with one or more other therapeutic compounds. In yet another embodiment,  
10           the invention features a method for reducing or preventing tissue rejection in a subject comprising administering to the subject a composition of the invention under conditions suitable for the reduction or prevention of tissue rejection in the subject.

          In one embodiment, the invention features a method for alleviating the symptoms of a disease, condition, trait, genotype or phenotype in a subject, comprising administering to  
15           the subject a composition of the invention (alone or in combination (simultaneously or sequentially) with one or more other therapeutic compounds) under conditions suitable for alleviating the symptoms of the disease, condition, trait, genotype or phenotype in the subject.

          In another embodiment, the invention features a method for validating a gene target,  
20           comprising: (a) synthesizing a siRNA molecule of the invention, which can be chemically-modified, wherein one of the siRNA strands includes a sequence complementary to RNA of a target gene; (b) introducing the siRNA molecule into a cell, tissue, or organism under conditions suitable for modulating expression of the target gene in the cell, tissue, or organism; and (c) determining the function of the gene by assaying for any phenotypic  
25           change in the cell, tissue, or organism.

          In another embodiment, the invention features a method for validating a target gene comprising: (a) synthesizing a siRNA molecule of the invention, which can be chemically-modified, wherein one of the siRNA strands includes a sequence complementary to RNA of a target gene; (b) introducing the siRNA molecule into a biological system under  
30           conditions suitable for modulating expression of the target gene in the biological system;

and (c) determining the function of the gene by assaying for any phenotypic change in the biological system.

By "biological system" is meant, material, in a purified or unpurified form, from biological sources, including but not limited to human, animal, plant, insect, bacterial, viral  
5 or other sources, wherein the system comprises the components required for RNAi activity. The term "biological system" includes, for example, a cell, tissue, or organism, or extract thereof. The term biological system also includes reconstituted RNAi systems that can be used in an *in vitro* setting.

By "phenotypic change" is meant any detectable change to a cell that occurs in  
10 response to contact or treatment with a nucleic acid molecule of the invention (e.g., siNA). Such detectable changes include, but are not limited to, changes in shape, size, proliferation, motility, protein expression or RNA expression or other physical or chemical changes as can be assayed by methods known in the art. The detectable change can also include  
15 expression of reporter genes/molecules such as Green Florescent Protein (GFP) or various tags that are used to identify an expressed protein or any other cellular component that can be assayed.

In one embodiment, the invention features a kit containing a siNA molecule of the invention, which can be chemically-modified, that can be used to modulate the expression of a target gene in biological system, including, for example, in a cell, tissue, or organism.  
20 In another embodiment, the invention features a kit containing more than one siNA molecule of the invention, which can be chemically-modified, that can be used to modulate the expression of more than one target gene in a biological system, including, for example, in a cell, tissue, or organism.

In one embodiment, the invention features a kit containing a siNA molecule of the  
25 invention, which can be chemically-modified, that can be used to modulate the expression of a target gene in a biological system. In another embodiment, the invention features a kit containing more than one siNA molecule of the invention, which can be chemically-modified, that can be used to modulate the expression of more than one target gene in a biological system.

In one embodiment, the invention features a cell containing one or more siNA molecules of the invention, which can be chemically-modified. In another embodiment, the cell containing a siNA molecule of the invention is a mammalian cell. In yet another embodiment, the cell containing a siNA molecule of the invention is a human cell.

- 5 In one embodiment, the synthesis of a siNA molecule of the invention, which can be chemically-modified, comprises: (a) synthesis of two complementary strands of the siNA molecule; (b) annealing the two complementary strands together under conditions suitable to obtain a double-stranded siNA molecule. In another embodiment, synthesis of the two complementary strands of the siNA molecule is by solid phase oligonucleotide synthesis.
- 10 In yet another embodiment, synthesis of the two complementary strands of the siNA molecule is by solid phase tandem oligonucleotide synthesis.

- In one embodiment, the invention features a method for synthesizing a siNA duplex molecule comprising: (a) synthesizing a first oligonucleotide sequence strand of the siNA molecule, wherein the first oligonucleotide sequence strand comprises a cleavable linker molecule that can be used as a scaffold for the synthesis of the second oligonucleotide sequence strand of the siNA; (b) synthesizing the second oligonucleotide sequence strand of siNA on the scaffold of the first oligonucleotide sequence strand, wherein the second oligonucleotide sequence strand further comprises a chemical moiety than can be used to purify the siNA duplex; (c) cleaving the linker molecule of (a) under conditions suitable for the two siNA oligonucleotide strands to hybridize and form a stable duplex; and (d) purifying the siNA duplex utilizing the chemical moiety of the second oligonucleotide sequence strand. In one embodiment, cleavage of the linker molecule in (c) above takes place during deprotection of the oligonucleotide, for example, under hydrolysis conditions using an alkylamine base such as methylamine. In one embodiment, the method of synthesis comprises solid phase synthesis on a solid support such as controlled pore glass (CPG) or polystyrene, wherein the first sequence of (a) is synthesized on a cleavable linker, such as a succinyl linker, using the solid support as a scaffold. The cleavable linker in (a) used as a scaffold for synthesizing the second strand can comprise similar reactivity as the solid support derivatized linker, such that cleavage of the solid support derivatized linker and the cleavable linker of (a) takes place concomitantly. In another embodiment, the chemical moiety of (b) that can be used to isolate the attached oligonucleotide sequence comprises a trityl group, for example a dimethoxytrityl group, which can be employed in a
- 15
- 20
- 25
- 30

trityl-on synthesis strategy as described herein. In yet another embodiment, the chemical moiety, such as a dimethoxytrityl group, is removed during purification, for example, using acidic conditions.

5 In a further embodiment, the method for siNA synthesis is a solution phase synthesis or hybrid phase synthesis wherein both strands of the siNA duplex are synthesized in tandem using a cleavable linker attached to the first sequence which acts a scaffold for synthesis of the second sequence. Cleavage of the linker under conditions suitable for hybridization of the separate siNA sequence strands results in formation of the double-stranded siNA molecule.

10 In another embodiment, the invention features a method for synthesizing a siNA duplex molecule comprising: (a) synthesizing one oligonucleotide sequence strand of the siNA molecule, wherein the sequence comprises a cleavable linker molecule that can be used as a scaffold for the synthesis of another oligonucleotide sequence; (b) synthesizing a second oligonucleotide sequence having complementarity to the first sequence strand on  
15 the scaffold of (a), wherein the second sequence comprises the other strand of the double-stranded siNA molecule and wherein the second sequence further comprises a chemical moiety than can be used to isolate the attached oligonucleotide sequence; (c) purifying the product of (b) utilizing the chemical moiety of the second oligonucleotide sequence strand under conditions suitable for isolating the full-length sequence comprising  
20 both siNA oligonucleotide strands connected by the cleavable linker and under conditions suitable for the two siNA oligonucleotide strands to hybridize and form a stable duplex. In one embodiment, cleavage of the linker molecule in (c) above takes place during deprotection of the oligonucleotide, for example under hydrolysis conditions. In another embodiment, cleavage of the linker molecule in (c) above takes place after deprotection of  
25 the oligonucleotide. In another embodiment, the method of synthesis comprises solid phase synthesis on a solid support such as controlled pore glass (CPG) or polystyrene, wherein the first sequence of (a) is synthesized on a cleavable linker, such as a succinyl linker, using the solid support as a scaffold. The cleavable linker in (a) used as a scaffold for synthesizing the second strand can comprise similar reactivity or differing reactivity as  
30 the solid support derivatized linker, such that cleavage of the solid support derivatized linker and the cleavable linker of (a) takes place either concomitantly or sequentially. In



one embodiment, the chemical moiety of (b) that can be used to isolate the attached oligonucleotide sequence comprises a trityl group, for example a dimethoxytrityl group.

In another embodiment, the invention features a method for making a double-stranded siNA molecule in a single synthetic process comprising: (a) synthesizing an oligonucleotide having a first and a second sequence, wherein the first sequence is complementary to the second sequence, and the first oligonucleotide sequence is linked to the second sequence via a cleavable linker, and wherein a terminal 5'-protecting group, for example, a 5'-O-dimethoxytrityl group (5'-O-DMT) remains on the oligonucleotide having the second sequence; (b) deprotecting the oligonucleotide whereby the deprotection results in the cleavage of the linker joining the two oligonucleotide sequences; and (c) purifying the product of (b) under conditions suitable for isolating the double-stranded siNA molecule, for example using a trityl-on synthesis strategy as described herein.

In another embodiment, the method of synthesis of siNA molecules of the invention comprises the teachings of Scaringe *et al.*, US Patent Nos. 5,889,136; 6,008,400; and 6,111,086, incorporated by reference herein in their entirety.

In one embodiment, the invention features siNA constructs that mediate RNAi in a cell or reconstituted system, wherein the siNA construct comprises one or more chemical modifications, for example, one or more chemical modifications having any of Formulae I-VII or any combination thereof that increases the nuclease resistance of the siNA construct.

In another embodiment, the invention features a method for generating siNA molecules with increased nuclease resistance comprising (a) introducing nucleotides having any of Formula I-VII or any combination thereof into a siNA molecule, and (b) assaying the siNA molecule of step (a) under conditions suitable for isolating siNA molecules having increased nuclease resistance.

In one embodiment, the invention features siNA constructs that mediate RNAi against a target gene, wherein the siNA construct comprises one or more chemical modifications described herein that modulates the binding affinity between the sense and antisense strands of the siNA construct.

In one embodiment, the binding affinity between the sense and antisense strands of the siNA construct is modulated to increase the activity of the siNA molecule with regard to the ability of the siNA to mediate RNA interference. In another embodiment the binding affinity between the sense and antisense strands of the siNA construct is decreased. The binding affinity between the sense and antisense strands of the siNA construct can be decreased by introducing one or more chemically modified nucleotides in the siNA sequence that disrupts the duplex stability of the siNA (e.g., lowers the  $T_m$  of the duplex). The binding affinity between the sense and antisense strands of the siNA construct can be decreased by introducing one or more nucleotides in the siNA sequence that do not form Watson-Crick base pairs. The binding affinity between the sense and antisense strands of the siNA construct can be decreased by introducing one or more wobble base pairs in the siNA sequence. The binding affinity between the sense and antisense strands of the siNA construct can be decreased by modifying the nucleobase composition of the siNA, such as by altering the G-C content of the siNA sequence (e.g., decreasing the number of G-C base pairs in the siNA sequence). These modifications and alterations in sequence can be introduced selectively at pre-determined positions of the siNA sequence to increase siNA mediated RNAi activity. For example, such modifications and sequence alterations can be introduced to disrupt siNA duplex stability between the 5'-end of the antisense strand and the 3'-end of the sense strand, the 3'-end of the antisense strand and the 5'-end of the sense strand, or alternately the middle of the siNA duplex. In another embodiment, siNA molecules are screened for optimized RNAi activity by introducing such modifications and sequence alterations either by rational design based upon observed rules or trends in increasing siNA activity, or randomly via combinatorial selection processes that cover either partial or complete sequence space of the siNA construct.

In another embodiment, the invention features a method for generating siNA molecules with increased binding affinity between the sense and antisense strands of the siNA molecule comprising (a) introducing nucleotides having any of Formula I-VII or any combination thereof into a siNA molecule, and (b) assaying the siNA molecule of step (a) under conditions suitable for isolating siNA molecules having increased binding affinity between the sense and antisense strands of the siNA molecule.

In another embodiment, the invention features a method for generating siNA molecules with decreased binding affinity between the sense and antisense strands of the

siNA molecule comprising (a) introducing nucleotides having any of Formula I-VII or any combination thereof into a siNA molecule, and (b) assaying the siNA molecule of step (a) under conditions suitable for isolating siNA molecules having decreased binding affinity between the sense and antisense strands of the siNA molecule.

5           In one embodiment, the invention features siNA constructs that mediate RNAi in a cell or reconstituted system, wherein the siNA construct comprises one or more chemical modifications described herein that modulates the binding affinity between the antisense strand of the siNA construct and a complementary target RNA sequence within a cell.

10           In one embodiment, the invention features siNA constructs that mediate RNAi in a cell or reconstituted system, wherein the siNA construct comprises one or more chemical modifications described herein that modulates the binding affinity between the antisense strand of the siNA construct and a complementary target DNA sequence within a cell.

15           In another embodiment, the invention features a method for generating siNA molecules with increased binding affinity between the antisense strand of the siNA molecule and a complementary target RNA sequence comprising (a) introducing nucleotides having any of Formula I-VII or any combination thereof into a siNA molecule, and (b) assaying the siNA molecule of step (a) under conditions suitable for isolating siNA molecules having increased binding affinity between the antisense strand of the siNA molecule and a complementary target RNA sequence.

20           In another embodiment, the invention features a method for generating siNA molecules with increased binding affinity between the antisense strand of the siNA molecule and a complementary target DNA sequence comprising (a) introducing nucleotides having any of Formula I-VII or any combination thereof into a siNA molecule, and (b) assaying the siNA molecule of step (a) under conditions suitable for isolating siNA molecules having increased binding affinity between the antisense strand of the siNA molecule and a complementary target DNA sequence.

25           In another embodiment, the invention features a method for generating siNA molecules with decreased binding affinity between the antisense strand of the siNA molecule and a complementary target RNA sequence comprising (a) introducing nucleotides having any of Formula I-VII or any combination thereof into a siNA molecule,

and (b) assaying the siNA molecule of step (a) under conditions suitable for isolating siNA molecules having decreased binding affinity between the antisense strand of the siNA molecule and a complementary target RNA sequence.

In another embodiment, the invention features a method for generating siNA molecules with decreased binding affinity between the antisense strand of the siNA molecule and a complementary target DNA sequence comprising (a) introducing nucleotides having any of Formula I-VII or any combination thereof into a siNA molecule, and (b) assaying the siNA molecule of step (a) under conditions suitable for isolating siNA molecules having decreased binding affinity between the antisense strand of the siNA molecule and a complementary target DNA sequence.

In one embodiment, the invention features siNA constructs that mediate RNAi in a cell or reconstituted system, wherein the siNA construct comprises one or more chemical modifications described herein that modulate the polymerase activity of a cellular polymerase capable of generating additional endogenous siNA molecules having sequence homology to the chemically-modified siNA construct.

In another embodiment, the invention features a method for generating siNA molecules capable of mediating increased polymerase activity of a cellular polymerase capable of generating additional endogenous siNA molecules having sequence homology to a chemically-modified siNA molecule comprising (a) introducing nucleotides having any of Formula I-VII or any combination thereof into a siNA molecule, and (b) assaying the siNA molecule of step (a) under conditions suitable for isolating siNA molecules capable of mediating increased polymerase activity of a cellular polymerase capable of generating additional endogenous siNA molecules having sequence homology to the chemically-modified siNA molecule. In one embodiment, the invention features chemically-modified siNA constructs that mediate RNAi in a cell or reconstituted system, wherein the chemical modifications do not significantly effect the interaction of siNA with a target RNA molecule, DNA molecule and/or proteins or other factors that are essential for RNAi in a manner that would decrease the efficacy of RNAi mediated by such siNA constructs.

In another embodiment, the invention features a method for generating siNA molecules with improved RNAi activity comprising (a) introducing nucleotides having any

of Formula I-VII or any combination thereof into a siNA molecule, and (b) assaying the siNA molecule of step (a) under conditions suitable for isolating siNA molecules having improved RNAi activity.

5 In yet another embodiment, the invention features a method for generating siNA molecules with improved RNAi activity against a target RNA comprising (a) introducing nucleotides having any of Formula I-VII or any combination thereof into a siNA molecule, and (b) assaying the siNA molecule of step (a) under conditions suitable for isolating siNA molecules having improved RNAi activity against the target RNA.

10 In yet another embodiment, the invention features a method for generating siNA molecules with improved RNAi activity against a DNA target comprising (a) introducing nucleotides having any of Formula I-VII or any combination thereof into a siNA molecule, and (b) assaying the siNA molecule of step (a) under conditions suitable for isolating siNA molecules having improved RNAi activity against the DNA target, such as a gene, chromosome, or portion thereof.

15 In one embodiment, the invention features siNA constructs that mediate RNAi in a cell or reconstituted system, wherein the siNA construct comprises one or more chemical modifications described herein that modulates the cellular uptake of the siNA construct.

20 In another embodiment, the invention features a method for generating siNA molecules against a target gene with improved cellular uptake comprising (a) introducing nucleotides having any of Formula I-VII or any combination thereof into a siNA molecule, and (b) assaying the siNA molecule of step (a) under conditions suitable for isolating siNA molecules having improved cellular uptake.

25 In one embodiment, the invention features siNA constructs that mediate RNAi against a target gene, wherein the siNA construct comprises one or more chemical modifications described herein that increases the bioavailability of the siNA construct, for example, by attaching polymeric conjugates such as polyethyleneglycol or equivalent conjugates that improve the pharmacokinetics of the siNA construct, or by attaching conjugates that target specific tissue types or cell types *in vivo*. Non-limiting examples of such conjugates are described in Vargeese *et al.*, U.S. Serial No. 10/201,394 incorporated  
30 by reference herein.

In one embodiment, the invention features a method for generating siNA molecules of the invention with improved bioavailability comprising (a) introducing a conjugate into the structure of a siNA molecule, and (b) assaying the siNA molecule of step (a) under conditions suitable for isolating siNA molecules having improved bioavailability. Such  
5 conjugates can include ligands for cellular receptors, such as peptides derived from naturally occurring protein ligands; protein localization sequences, including cellular ZIP code sequences; antibodies; nucleic acid aptamers; vitamins and other co-factors, such as folate and N-acetylgalactosamine; polymers, such as polyethyleneglycol (PEG); phospholipids; cholesterol; polyamines, such as spermine or spermidine; and others.

10 In one embodiment, the invention features a double stranded short interfering nucleic acid (siNA) molecule that comprises a first nucleotide sequence complementary to a target RNA sequence or a portion thereof, and a second sequence having complementarity to said first sequence, wherein said second sequence is chemically modified in a manner that it can no longer act as a guide sequence for efficiently mediating RNA interference and/or is  
15 recognized by cellular proteins that facilitate RNAi.

In one embodiment, the invention features a double stranded short interfering nucleic acid (siNA) molecule that comprises a first nucleotide sequence complementary to a target RNA sequence or a portion thereof, and a second sequence having complementarity to said first sequence, wherein the second sequence is designed or modified in a manner that  
20 prevents its entry into the RNAi pathway as a guide sequence or as a sequence that is complementary to a target nucleic acid (e.g., RNA) sequence. Such design or modifications are expected to enhance the activity of siNA and/or improve the specificity of siNA molecules of the invention. These modifications are also expected to minimize any off-target effects and/or associated toxicity.

25 In one embodiment, the invention features a double stranded short interfering nucleic acid (siNA) molecule that comprises a first nucleotide sequence complementary to a target RNA sequence or a portion thereof, and a second sequence having complementarity to said first sequence, wherein said second sequence is incapable of acting as a guide sequence for mediating RNA interference.

30 In one embodiment, the invention features a double stranded short interfering nucleic acid (siNA) molecule that comprises a first nucleotide sequence complementary to a target

RNA sequence or a portion thereof, and a second sequence having complementarity to said first sequence, wherein said second sequence does not have a terminal 5'-hydroxyl (5'-OH) or 5'-phosphate group.

In one embodiment, the invention features a double stranded short interfering nucleic acid (siNA) molecule that comprises a first nucleotide sequence complementary to a target  
5 RNA sequence or a portion thereof, and a second sequence having complementarity to said first sequence, wherein said second sequence comprises a terminal cap moiety at the 5'-end of said second sequence. In another embodiment, the terminal cap moiety comprises an inverted abasic, inverted deoxy abasic, inverted nucleotide moiety, a group shown in  
10 **Figure 22**, an alkyl or cycloalkyl group, a heterocycle, or any other group that prevents RNAi activity in which the second sequence serves as a guide sequence or template for RNAi.

In one embodiment, the invention features a double stranded short interfering nucleic acid (siNA) molecule that comprises a first nucleotide sequence complementary to a target  
15 RNA sequence or a portion thereof, and a second sequence having complementarity to said first sequence, wherein said second sequence comprises a terminal cap moiety at the 5'-end and 3'-end of said second sequence. In another embodiment, each terminal cap moiety individually comprises an inverted abasic, inverted deoxy abasic, inverted nucleotide moiety, a group shown in **Figure 22**, an alkyl or cycloalkyl group, a heterocycle, or any  
20 other group that prevents RNAi activity in which the second sequence serves as a guide sequence or template for RNAi.

In one embodiment, the invention features a method for generating siNA molecules of the invention with improved specificity for down regulating or inhibiting the expression  
of a target nucleic acid (e.g., a DNA or RNA such as a gene or its corresponding RNA),  
25 comprising (a) introducing one or more chemical modifications into the structure of a siNA molecule, and (b) assaying the siNA molecule of step (a) under conditions suitable for isolating siNA molecules having improved specificity. In another embodiment, the chemical modification used to improve specificity comprises terminal cap modifications at the 5'-end, 3'-end, or both 5' and 3'-ends of the siNA molecule. The terminal cap  
30 modifications can comprise, for example, structures shown in **Figure 22** (e.g., inverted deoxyabasic moieties) or any other chemical modification that renders a portion of the

siNA molecule (e.g., the sense strand) incapable of mediating RNA interference against an off target nucleic acid sequence. In a non-limiting example, a siNA molecule is designed such that only the antisense sequence of the siNA molecule can serve as a guide sequence for RISC mediated degradation of a corresponding target RNA sequence. This can be accomplished by rendering the sense sequence of the siNA inactive by introducing chemical modifications to the sense strand that preclude recognition of the sense strand as a guide sequence by RNAi machinery. In one embodiment, such chemical modifications comprise any chemical group at the 5'-end of the sense strand of the siNA, or any other group that serves to render the sense strand inactive as a guide sequence for mediating RNA interference. These modifications, for example, can result in a molecule where the 5'-end of the sense strand no longer has a free 5'-hydroxyl (5'-OH) or a free 5'-phosphate group (e.g., phosphate, diphosphate, triphosphate, cyclic phosphate etc.). Non-limiting examples of such siNA constructs are described herein, such as "Stab 9/10", "Stab 7/8", "Stab 7/19", "Stab 17/22", "Stab 23/24", and "Stab 23/25" chemistries (**Table IV**) and variants thereof wherein the 5'-end and 3'-end of the sense strand of the siNA do not comprise a hydroxyl group or phosphate group.

In one embodiment, the invention features a method for generating siNA molecules of the invention with improved specificity for down regulating or inhibiting the expression of a target nucleic acid (e.g., a DNA or RNA such as a gene or its corresponding RNA), comprising introducing one or more chemical modifications into the structure of a siNA molecule that prevent a strand or portion of the siNA molecule from acting as a template or guide sequence for RNAi activity. In one embodiment, the inactive strand or sense region of the siNA molecule is the sense strand or sense region of the siNA molecule, i.e. the strand or region of the siNA that does not have complementarity to the target nucleic acid sequence. In one embodiment, such chemical modifications comprise any chemical group at the 5'-end of the sense strand or region of the siNA that does not comprise a 5'-hydroxyl (5'-OH) or 5'-phosphate group, or any other group that serves to render the sense strand or sense region inactive as a guide sequence for mediating RNA interference. Non-limiting examples of such siNA constructs are described herein, such as "Stab 9/10", "Stab 7/8", "Stab 7/19", "Stab 17/22", "Stab 23/24", and "Stab 23/25" chemistries (**Table IV**) and variants thereof wherein the 5'-end and 3'-end of the sense strand of the siNA do not comprise a hydroxyl group or phosphate group.



In one embodiment, the invention features a method for screening siNA molecules against a target nucleic acid sequence comprising, (a) generating a plurality of unmodified siNA molecules, (b) assaying the siNA molecules of step (a) under conditions suitable for isolating siNA molecules that are active in mediating RNA interference against the target  
5 nucleic acid sequence, (c) introducing chemical modifications (e.g., chemical modifications as described herein or as otherwise known in the art) into the active siNA molecules of (b), and (d) optionally re-screening the chemically modified siNA molecules of (c) under conditions suitable for isolating chemically modified siNA molecules that are active in mediating RNA interference against the target nucleic acid sequence.

10 In one embodiment, the invention features a method for screening siNA molecules against a target nucleic acid sequence comprising, (a) generating a plurality of chemically modified siNA molecules (e.g., siNA molecules as described herein or as otherwise known in the art), and (b) assaying the siNA molecules of step (a) under conditions suitable for isolating chemically modified siNA molecules that are active in mediating RNA  
15 interference against the target nucleic acid sequence.

In another embodiment, the invention features a method for generating siNA molecules of the invention with improved bioavailability comprising (a) introducing an excipient formulation to a siNA molecule, and (b) assaying the siNA molecule of step (a) under conditions suitable for isolating siNA molecules having improved bioavailability.  
20 Such excipients include polymers such as cyclodextrins, lipids, cationic lipids, polyamines, phospholipids, nanoparticles, receptors, ligands, and others.

In another embodiment, the invention features a method for generating siNA molecules of the invention with improved bioavailability comprising (a) introducing an excipient formulation to a siNA molecule, and (b) assaying the siNA molecule of step (a)  
25 under conditions suitable for isolating siNA molecules having improved bioavailability. Such excipients include polymers such as cyclodextrins, lipids, cationic lipids, polyamines, phospholipids, and others.

In another embodiment, the invention features a method for generating siNA molecules of the invention with improved bioavailability comprising (a) introducing  
30 nucleotides having any of Formulae I-VII or any combination thereof into a siNA molecule,

and (b) assaying the siNA molecule of step (a) under conditions suitable for isolating siNA molecules having improved bioavailability.

In another embodiment, polyethylene glycol (PEG) can be covalently attached to siNA compounds of the present invention. The attached PEG can be any molecular weight, preferably from about 2,000 to about 50,000 daltons (Da).

The present invention can be used alone or as a component of a kit having at least one of the reagents necessary to carry out the *in vitro* or *in vivo* introduction of RNA to test samples and/or subjects. For example, preferred components of the kit include a siNA molecule of the invention and a vehicle that promotes introduction of the siNA into cells of interest as described herein (e.g., using lipids and other methods of transfection known in the art, see for example Beigelman *et al.*, US 6,395,713). The kit can be used for target validation, such as in determining gene function and/or activity, or in drug optimization, and in drug discovery (see for example Usman *et al.*, USSN 60/402,996). Such a kit can also include instructions to allow a user of the kit to practice the invention.

The term "short interfering nucleic acid", "siNA", "short interfering RNA", "siRNA", "short interfering nucleic acid molecule", "short interfering oligonucleotide molecule", or "chemically-modified short interfering nucleic acid molecule" as used herein refers to any nucleic acid molecule capable of inhibiting or down regulating gene expression or viral replication, for example by mediating RNA interference "RNAi" or gene silencing in a sequence-specific manner; see for example Zamore *et al.*, 2000, *Cell*, 101, 25-33; Bass, 2001, *Nature*, 411, 428-429; Elbashir *et al.*, 2001, *Nature*, 411, 494-498; and Kreutzer *et al.*, International PCT Publication No. WO 00/44895; Zernicka-Goetz *et al.*, International PCT Publication No. WO 01/36646; Fire, International PCT Publication No. WO 99/32619; Plaetinck *et al.*, International PCT Publication No. WO 00/01846; Mello and Fire, International PCT Publication No. WO 01/29058; Deschamps-Depaillette, International PCT Publication No. WO 99/07409; and Li *et al.*, International PCT Publication No. WO 00/44914; Allshire, 2002, *Science*, 297, 1818-1819; Volpe *et al.*, 2002, *Science*, 297, 1833-1837; Jenuwein, 2002, *Science*, 297, 2215-2218; and Hall *et al.*, 2002, *Science*, 297, 2232-2237; Hutvagner and Zamore, 2002, *Science*, 297, 2056-60; McManus *et al.*, 2002, *RNA*, 8, 842-850; Reinhart *et al.*, 2002, *Gene & Dev.*, 16, 1616-1626; and Reinhart & Bartel, 2002, *Science*, 297, 1831). Non limiting examples of siNA molecules of the

invention are shown in **Figures 18-20**, and **Table I** herein. For example the siNA can be a double-stranded polynucleotide molecule comprising self-complementary sense and antisense regions, wherein the antisense region comprises nucleotide sequence that is complementary to nucleotide sequence in a target nucleic acid molecule or a portion thereof and the sense region having nucleotide sequence corresponding to the target nucleic acid sequence or a portion thereof. The siNA can be assembled from two separate oligonucleotides, where one strand is the sense strand and the other is the antisense strand, wherein the antisense and sense strands are self-complementary (i.e. each strand comprises nucleotide sequence that is complementary to nucleotide sequence in the other strand; such as where the antisense strand and sense strand form a duplex or double stranded structure, for example wherein the double stranded region is about 19 base pairs); the antisense strand comprises nucleotide sequence that is complementary to nucleotide sequence in a target nucleic acid molecule or a portion thereof and the sense strand comprises nucleotide sequence corresponding to the target nucleic acid sequence or a portion thereof. Alternatively, the siNA is assembled from a single oligonucleotide, where the self-complementary sense and antisense regions of the siNA are linked by means of a nucleic acid based or non-nucleic acid-based linker(s). The siNA can be a polynucleotide with a duplex, asymmetric duplex, hairpin or asymmetric hairpin secondary structure, having self-complementary sense and antisense regions, wherein the antisense region comprises nucleotide sequence that is complementary to nucleotide sequence in a separate target nucleic acid molecule or a portion thereof and the sense region having nucleotide sequence corresponding to the target nucleic acid sequence or a portion thereof. The siNA can be a circular single-stranded polynucleotide having two or more loop structures and a stem comprising self-complementary sense and antisense regions, wherein the antisense region comprises nucleotide sequence that is complementary to nucleotide sequence in a target nucleic acid molecule or a portion thereof and the sense region having nucleotide sequence corresponding to the target nucleic acid sequence or a portion thereof, and wherein the circular polynucleotide can be processed either *in vivo* or *in vitro* to generate an active siNA molecule capable of mediating RNAi. The siNA can also comprise a single stranded polynucleotide having nucleotide sequence complementary to nucleotide sequence in a target nucleic acid molecule or a portion thereof (for example, where such siNA molecule does not require the presence within the siNA molecule of nucleotide sequence corresponding to the target nucleic acid sequence or a portion thereof), wherein

the single stranded polynucleotide can further comprise a terminal phosphate group, such as a 5'-phosphate (see for example Martinez *et al.*, 2002, *Cell.*, 110, 563-574 and Schwarz *et al.*, 2002, *Molecular Cell*, 10, 537-568), or 5',3'-diphosphate. In certain embodiment, the siNA molecule of the invention comprises separate sense and antisense sequences or regions, wherein the sense and antisense regions are covalently linked by nucleotide or non-nucleotide linkers molecules as is known in the art, or are alternately non-covalently linked by ionic interactions, hydrogen bonding, van der waals interactions, hydrophobic intercatations, and/or stacking interactions. In certain embodiments, the siNA molecules of the invention comprise nucleotide sequence that is complementary to nucleotide sequence of a target gene. In another embodiment, the siNA molecule of the invention interacts with nucleotide sequence of a target gene in a manner that causes inhibition of expression of the target gene. As used herein, siNA molecules need not be limited to those molecules containing only RNA, but further encompasses chemically-modified nucleotides and non-nucleotides. In certain embodiments, the short interfering nucleic acid molecules of the invention lack 2'-hydroxy (2'-OH) containing nucleotides. Applicant describes in certain embodiments short interfering nucleic acids that do not require the presence of nucleotides having a 2'-hydroxy group for mediating RNAi and as such, short interfering nucleic acid molecules of the invention optionally do not include any ribonucleotides (e.g., nucleotides having a 2'-OH group). Such siNA molecules that do not require the presence of ribonucleotides within the siNA molecule to support RNAi can however have an attached linker or linkers or other attached or associated groups, moieties, or chains containing one or more nucleotides with 2'-OH groups. Optionally, siNA molecules can comprise ribonucleotides at about 5, 10, 20, 30, 40, or 50% of the nucleotide positions. The modified short interfering nucleic acid molecules of the invention can also be referred to as short interfering modified oligonucleotides "siMON." As used herein, the term siNA is meant to be equivalent to other terms used to describe nucleic acid molecules that are capable of mediating sequence specific RNAi, for example short interfering RNA (siRNA), double-stranded RNA (dsRNA), micro-RNA (miRNA), short hairpin RNA (shRNA), short interfering oligonucleotide, short interfering nucleic acid, short interfering modified oligonucleotide, chemically-modified siRNA, post-transcriptional gene silencing RNA (ptgsRNA), and others. In addition, as used herein, the term RNAi is meant to be equivalent to other terms used to describe sequence specific RNA interference, such as post transcriptional gene silencing, translational inhibition, or epigenetics. For example, siNA

molecules of the invention can be used to epigenetically silence genes at both the post-transcriptional level or the pre-transcriptional level. In a non-limiting example, epigenetic regulation of gene expression by siNA molecules of the invention can result from siNA mediated modification of chromatin structure to alter gene expression (see, for  
5 example, Verdel *et al.*, 2004, *Science*, 303, 672-676; Pal-Bhadra *et al.*, 2004, *Science*, 303, 669-672; Allshire, 2002, *Science*, 297, 1818-1819; Volpe *et al.*, 2002, *Science*, 297, 1833-1837; Jenuwein, 2002, *Science*, 297, 2215-2218; and Hall *et al.*, 2002, *Science*, 297, 2232-2237).

In one embodiment, a siNA molecule of the invention is a duplex forming  
10 oligonucleotide "DFO", (see for example **Figures 93-94** and Vaish *et al.*, USSN 10/727,780 filed December 3, 2003).

In one embodiment, a siNA molecule of the invention is a multifunctional siNA, or a multi-targeted (see for example **Figures 95-101** and Jadhavi *et al.*, USSN 60/543,480 filed February 10, 2004). The multifunctional siNA of the invention can comprise nucleotide  
15 sequence totargeting, for example, two regions of a target RNA or nucleotide sequences in two distinct target RNAs (see for example target sequences in **Table I**).

By "asymmetric hairpin" as used herein is meant a linear siNA molecule comprising an antisense region, a loop portion that can comprise nucleotides or non-nucleotides, and a sense region that comprises fewer nucleotides than the antisense region to the extent that  
20 the sense region has enough complimentary nucleotides to base pair with the antisense region and form a duplex with loop. For example, an asymmetric hairpin siNA molecule of the invention can comprise an antisense region having length sufficient to mediate RNAi in a cell or in vitro system (e.g., about 19 to about 22 nucleotides) and a loop region comprising about 4 to about 8 nucleotides, and a sense region having about 3 to about 18  
25 nucleotides that are complementary to the antisense region (see for example **Figure 74**). The asymmetric hairpin siNA molecule can also comprise a 5'-terminal phosphate group that can be chemically modified (for example as shown in **Figure 75**). The loop portion of the asymmetric hairpin siNA molecule can comprise nucleotides, non-nucleotides, linker molecules, or conjugate molecules as described herein.

30 By "asymmetric duplex" as used herein is meant a siNA molecule having two separate strands comprising a sense region and an antisense region, wherein the sense

region comprises fewer nucleotides than the antisense region to the extent that the sense region has enough complimentary nucleotides to base pair with the antisense region and form a duplex. For example, an asymmetric duplex siNA molecule of the invention can comprise an antisense region having length sufficient to mediate RNAi in a cell or in vitro system (e.g., about 19 to about 22 nucleotides) and a sense region having about 3 to about 18 nucleotides that are complementary to the antisense region (see for example **Figure 74**).

By "modulate" is meant that the expression of the gene, or level of RNA molecule or equivalent RNA molecules encoding one or more proteins or protein subunits, or activity of one or more proteins or protein subunits is up regulated or down regulated, such that expression, level, or activity is greater than or less than that observed in the absence of the modulator. For example, the term "modulate" can mean "inhibit," but the use of the word "modulate" is not limited to this definition.

By "inhibit", "down-regulate", or "reduce", it is meant that the expression of the gene, or level of RNA molecules or equivalent RNA molecules encoding one or more proteins or protein subunits, or activity of one or more proteins or protein subunits, is reduced below that observed in the absence of the nucleic acid molecules (e.g., siNA) of the invention. In one embodiment, inhibition, down-regulation or reduction with an siNA molecule is below that level observed in the presence of an inactive or attenuated molecule. In another embodiment, inhibition, down-regulation, or reduction with siNA molecules is below that level observed in the presence of, for example, an siNA molecule with scrambled sequence or with mismatches. In another embodiment, inhibition, down-regulation, or reduction of gene expression with a nucleic acid molecule of the instant invention is greater in the presence of the nucleic acid molecule than in its absence.

By "palindrome" or "repeat" nucleic acid sequence is meant a nucleic acid sequence whose 5'-to-3' sequence is identical to its complementary sequence in a duplex. For example, a palindrome sequence of the invention in a duplex can comprise sequence having the same sequence when one strand of the duplex is read in the 5'-to- 3' direction (left to right) and the sequence other strand based paired to it is read in the 3'- to- 5' direction (right to left). In another example, a repeat sequence of the invention can comprise a sequence having repeated nucleotides so arranged as to provide self complementarity when the sequence self-hybridizes (e.g., 5'-AUAU...-3'; 5'-AAUU...-3');

5'-UAUA...-3'; 5'-UUAA...-3'; 5'-CGCG...-3'; 5'-CCGG...-3', 5'-GGCC...-3';  
5'-CCGG...-3'; or any expanded repeat thereof etc.). The palindrome or repeat sequence  
can comprise about 2 to about 24 nucleotides in even numbers, (e.g., 2, 4, 6, 8, 10, 12, 14,  
16, 18, 20, 22, or 24 nucleotides). All that is required of the palindrome or repeat sequence  
5 is that it comprises nucleic acid sequence whose 5'-to-3' sequence is identical when present  
in a duplex, either alone or as part of a longer nucleic acid sequence. The palindrome or  
repeat sequence of the invention can comprise chemical modifications as described herein  
that can form, for example, Watson Crick or non-Watson Crick base pairs.

By "gene", or "target gene", is meant, a nucleic acid that encodes an RNA, for  
10 example, nucleic acid sequences including, but not limited to, structural genes encoding a  
polypeptide. A gene or target gene can also encode a functional RNA (fRNA) or  
non-coding RNA (ncRNA), such as small temporal RNA (stRNA), micro RNA (miRNA),  
small nuclear RNA (snRNA), short interfering RNA (siRNA), small nucleolar RNA  
(snoRNA), ribosomal RNA (rRNA), transfer RNA (tRNA) and precursor RNAs thereof.  
15 Such non-coding RNAs can serve as target nucleic acid molecules for siRNA mediated RNA  
interference in modulating the activity of fRNA or ncRNA involved in functional or  
regulatory cellular processes. Abberant fRNA or ncRNA activity leading to disease can  
therefore be modulated by siRNA molecules of the invention. siRNA molecules targeting  
fRNA and ncRNA can also be used to manipulate or alter the genotype or phenotype of an  
20 organism or cell, by intervening in cellular processes such as genetic imprinting,  
transcription, translation, or nucleic acid processing (e.g., transamination, methylation etc.).  
The target gene can be a gene derived from a cell, an endogenous gene, a transgene, or  
exogenous genes such as genes of a pathogen, for example a virus, which is present in the  
cell after infection thereof. The cell containing the target gene can be derived from or  
25 contained in any organism, for example a plant, animal, protozoan, virus, bacterium, or  
fungus. Non-limiting examples of plants include monocots, dicots, or gymnosperms.  
Non-limiting examples of animals include vertebrates or invertebrates. Non-limiting  
examples of fungi include molds or yeasts.

By "non-canonical base pair" is meant any non-Watson Crick base pair, such as  
30 mismatches and/or wobble base pairs, including flipped mismatches, single hydrogen bond  
mismatches, trans-type mismatches, triple base interactions, and quadruple base  
interactions. Non-limiting examples of such non-canonical base pairs include, but are not

limited to, AC reverse Hoogsteen, AC wobble, AU reverse Hoogsteen, GU wobble, AA N7 amino, CC 2-carbonyl-amino(H1)-N3-amino(H2), GA sheared, UC 4-carbonyl-amino, UU imino-carbonyl, AC reverse wobble, AU Hoogsteen, AU reverse Watson Crick, CG reverse Watson Crick, GC N3-amino-amino N3, AA N1-amino symmetric, AA N7-amino  
 5 symmetric, GA N7-N1 amino-carbonyl, GA+ carbonyl-amino N7-N1, GG N1-carbonyl symmetric, GG N3-amino symmetric, CC carbonyl-amino symmetric, CC N3-amino symmetric, UU 2-carbonyl-imino symmetric, UU 4-carbonyl-imino symmetric, AA amino-N3, AA N1-amino, AC amino 2-carbonyl, AC N3-amino, AC N7-amino, AU amino-4-carbonyl, AU N1-imino, AU N3-imino, AU N7-imino, CC carbonyl-amino, GA  
 10 amino-N1, GA amino-N7, GA carbonyl-amino, GA N3-amino, GC amino-N3, GC carbonyl-amino, GC N3-amino, GC N7-amino, GG amino-N7, GG carbonyl-imino, GG N7-amino, GU amino-2-carbonyl, GU carbonyl-imino, GU imino-2-carbonyl, GU N7-imino, psiU imino-2-carbonyl, UC 4-carbonyl-amino, UC imino-carbonyl, UU imino-4-carbonyl, AC C2-H-N3, GA carbonyl-C2-H, UU imino-4-carbonyl 2  
 15 carbonyl-C5-H, AC amino(A) N3(C)-carbonyl, GC imino amino-carbonyl, Gpsi imino-2-carbonyl amino-2- carbonyl, and GU imino amino-2-carbonyl base pairs.

By “homologous sequence” is meant, a nucleotide sequence that is shared by one or more polynucleotide sequences, such as genes, gene transcripts and/or non-coding polynucleotides. For example, a homologous sequence can be a nucleotide sequence that is  
 20 shared by two or more genes encoding related but different proteins, such as different members of a gene family (e.g., VEGF receptors such as VEGFr1, VEGFr2, and/or VEGFr3), different protein epitopes (e.g., different viral strains), different protein isoforms (e.g., VEGF A, B, C, and/or D) or completely divergent genes, such as a cytokine and its corresponding receptors (e.g., VEGF and VEGF receptors). A homologous sequence can  
 25 be a nucleotide sequence that is shared by two or more non-coding polynucleotides, such as noncoding DNA or RNA, regulatory sequences, introns, and sites of transcriptional control or regulation. Homologous sequences can also include conserved sequence regions shared by more than one polynucleotide sequence. The homology does not need to be perfect homology (e.g., 100%), as partially homologous sequences are also contemplated by the  
 30 instant invention (e.g., 99%, 98%, 97%, 96%, 95%, 94%, 93%, 92%, 91%, 90%, 89%, 88%, 87%, 86%, 85%, 84%, 83%, 82%, 81%, 80% etc.).



By "conserved sequence region" is meant, a nucleotide sequence of one or more regions in a polynucleotide that does not vary significantly between generations or from one biological system or organism to another biological system or organism. The polynucleotide can include both coding and non-coding DNA and RNA.

5 By "cancer" is meant a group of diseases characterized by uncontrolled growth and spread of abnormal cells.

By "sense region" is meant a nucleotide sequence of a siNA molecule having complementarity to an antisense region of the siNA molecule. In addition, the sense region of a siNA molecule can comprise a nucleic acid sequence having homology with a target  
10 nucleic acid sequence.

By "antisense region" is meant a nucleotide sequence of a siNA molecule having complementarity to a target nucleic acid sequence. In addition, the antisense region of a siNA molecule can optionally comprise a nucleic acid sequence having complementarity to a sense region of the siNA molecule.

15 By "target nucleic acid" is meant any nucleic acid sequence whose expression or activity is to be modulated. The target nucleic acid can be DNA "target DNA" or RNA "target RNA", such as endogenous DNA or RNA, viral DNA or viral RNA, or other RNA encoded by a gene, virus, bacteria, fungus, mammal, or plant.

By "complementarity" is meant that a nucleic acid can form hydrogen bond(s) with  
20 another nucleic acid sequence by either traditional Watson-Crick or other non-traditional types. In reference to the nucleic molecules of the present invention, the binding free energy for a nucleic acid molecule with its complementary sequence is sufficient to allow the relevant function of the nucleic acid to proceed, e.g., RNAi activity. Determination of binding free energies for nucleic acid molecules is well known in the art (see, e.g., Turner *et al.*, 1987, *CSH Symp. Quant. Biol.* LII pp.123-133; Frier *et al.*, 1986, *Proc. Nat. Acad. Sci.* USA 83:9373-9377; Turner *et al.*, 1987, *J. Am. Chem. Soc.* 109:3783-3785). A percent complementarity indicates the percentage of contiguous residues in a nucleic acid molecule that can form hydrogen bonds (e.g., Watson-Crick base pairing) with a second nucleic acid sequence (e.g., 5, 6, 7, 8, 9, or 10 nucleotides out of a total of 10 nucleotides in the first  
25 oligonucleotide being based paired to a second nucleic acid sequence having 10 nucleotides  
30

represents 50%, 60%, 70%, 80%, 90%, and 100% complementary respectively). "Perfectly complementary" means that all the contiguous residues of a nucleic acid sequence will hydrogen bond with the same number of contiguous residues in a second nucleic acid sequence.

5           The siNA molecules of the invention represent a novel therapeutic approach to a broad spectrum of diseases and conditions, including cancer or cancerous disease, infectious disease, cardiovascular disease, neurologic disease, ocular disease, prion disease, inflammatory disease, autoimmune disease, pulmonary disease, renal disease, liver disease, mitochondrial disease, endocrine disease, reproduction related diseases and conditions as  
10 are known in the art, and any other indications that can respond to the level of an expressed gene product in a cell or organism (see for example McSwiggen, International PCT Publication No. WO 03/74654).

By "proliferative disease" or "cancer" as used herein is meant, any disease, condition, trait, genotype or phenotype characterized by unregulated cell growth or replication as  
15 known in the art; including AIDS related cancers such as Kaposi's sarcoma; breast cancers; bone cancers such as Osteosarcoma, Chondrosarcomas, Ewing's sarcoma, Fibrosarcomas, Giant cell tumors, Adamantinomas, and Chordomas; Brain cancers such as Meningiomas, Glioblastomas, Lower-Grade Astrocytomas, Oligodendrocytomas, Pituitary Tumors, Schwannomas, and Metastatic brain cancers; cancers of the head and neck including  
20 various lymphomas such as mantle cell lymphoma, non-Hodgkins lymphoma, adenoma, squamous cell carcinoma, laryngeal carcinoma, gallbladder and bile duct cancers, cancers of the retina such as retinoblastoma, cancers of the esophagus, gastric cancers, multiple myeloma, ovarian cancer, uterine cancer, thyroid cancer, testicular cancer, endometrial cancer, melanoma, colorectal cancer, lung cancer, bladder cancer, prostate cancer, lung  
25 cancer (including non-small cell lung carcinoma), pancreatic cancer, sarcomas, Wilms' tumor, cervical cancer, head and neck cancer, skin cancers, nasopharyngeal carcinoma, liposarcoma, epithelial carcinoma, renal cell carcinoma, gallbladder adeno carcinoma, parotid adenocarcinoma, endometrial sarcoma, multidrug resistant cancers; and proliferative diseases and conditions, such as neovascularization associated with tumor  
30 angiogenesis, macular degeneration (e.g., wet/dry AMD), corneal neovascularization, diabetic retinopathy, neovascular glaucoma, myopic degeneration and other proliferative diseases and conditions such as restenosis and polycystic kidney disease, and any other

cancer or proliferative disease, condition, trait, genotype or phenotype that can respond to the modulation of disease related gene expression in a cell or tissue, alone or in combination with other therapies.

By “inflammatory disease” or “inflammatory condition” as used herein is meant any disease, condition, trait, genotype or phenotype characterized by an inflammatory or allergic process as is known in the art, such as inflammation, acute inflammation, chronic inflammation, atherosclerosis, restenosis, asthma, allergic rhinitis, atopic dermatitis, septic shock, rheumatoid arthritis, inflammatory bowel disease, inflammatory pelvic disease, pain, ocular inflammatory disease, celiac disease, Leigh Syndrome, Glycerol Kinase Deficiency, Familial eosinophilia (FE), autosomal recessive spastic ataxia, laryngeal inflammatory disease; Tuberculosis, Chronic cholecystitis, Bronchiectasis, Silicosis and other pneumoconioses, and any other inflammatory disease, condition, trait, genotype or phenotype that can respond to the modulation of disease related gene expression in a cell or tissue, alone or in combination with other therapies.

By “autoimmune disease” or “autoimmune condition” as used herein is meant, any disease, condition, trait, genotype or phenotype characterized by autoimmunity as is known in the art, such as multiple sclerosis, diabetes mellitus, lupus, celiac disease, Crohn’s disease, ulcerative colitis, Guillain-Barre syndrome, scleroderms, Goodpasture’s syndrome, Wegener’s granulomatosis, autoimmune epilepsy, Rasmussen’s encephalitis, Primary biliary sclerosis, Sclerosing cholangitis, Autoimmune hepatitis, Addison’s disease, Hashimoto’s thyroiditis, Fibromyalgia, Menier’s syndrome; transplantation rejection (e.g., prevention of allograft rejection) pernicious anemia, rheumatoid arthritis, systemic lupus erythematosus, dermatomyositis, Sjogren's syndrome, lupus erythematosus, multiple sclerosis, myasthenia gravis, Reiter's syndrome, Grave's disease, and any other autoimmune disease, condition, trait, genotype or phenotype that can respond to the modulation of disease related gene expression in a cell or tissue, alone or in combination with other therapies.

By “nuerologic disease” or “neurological disease” is meant any disease, disorder, or condition affecting the central or peripheral nervous system, including ADHD, AIDS - Neurological Complications, Absence of the Septum Pellucidum, Acquired Epileptiform Aphasia, Acute Disseminated Encephalomyelitis, Adrenoleukodystrophy, Agenesis of the

Corpus Callosum, Agnosia, Aicardi Syndrome, Alexander Disease, Alpers' Disease, Alternating Hemiplegia, Alzheimer's Disease, Amyotrophic Lateral Sclerosis, Anencephaly, Aneurysm, Angelman Syndrome, Angiomas, Anoxia, Aphasia, Apraxia, Arachnoid Cysts, Arachnoiditis, Arnold-Chiari Malformation, Arteriovenous  
5 Malformation, Aspartame, Asperger Syndrome, Ataxia Telangiectasia, Ataxia, Attention Deficit-Hyperactivity Disorder, Autism, Autonomic Dysfunction, Back Pain, Barth Syndrome, Batten Disease, Behcet's Disease, Bell's Palsy, Benign Essential Blepharospasm, Benign Focal Amyotrophy, Benign Intracranial Hypertension, Bernhardt-Roth Syndrome, Binswanger's Disease, Blepharospasm, Bloch-Sulzberger  
10 Syndrome, Brachial Plexus Birth Injuries, Brachial Plexus Injuries, Bradbury-Eggleston Syndrome, Brain Aneurysm, Brain Injury, Brain and Spinal Tumors, Brown-Sequard Syndrome, Bulbospinal Muscular Atrophy, Canavan Disease, Carpal Tunnel Syndrome, Causalgia, Cavemomas, Cavernous Angioma, Cavernous Malformation, Central Cervical Cord Syndrome, Central Cord Syndrome, Central Pain Syndrome, Cephalic Disorders,  
15 Cerebellar Degeneration, Cerebellar Hypoplasia, Cerebral Aneurysm, Cerebral Arteriosclerosis, Cerebral Atrophy, Cerebral Beriberi, Cerebral Gigantism, Cerebral Hypoxia, Cerebral Palsy, Cerebro-Oculo-Facio-Skeletal Syndrome, Charcot-Marie-Tooth Disorder, Chiari Malformation, Chorea, Choreoacanthocytosis, Chronic Inflammatory Demyelinating Polyneuropathy (CIDP), Chronic Orthostatic Intolerance, Chronic Pain,  
20 Cockayne Syndrome Type II, Coffin Lowry Syndrome, Coma, including Persistent Vegetative State, Complex Regional Pain Syndrome, Congenital Facial Diplegia, Congenital Myasthenia, Congenital Myopathy, Congenital Vascular Cavernous Malformations, Corticobasal Degeneration, Cranial Arteritis, Craniosynostosis, Creutzfeldt-Jakob Disease, Cumulative Trauma Disorders, Cushing's Syndrome,  
25 Cytomegalic Inclusion Body Disease (CIBD), Cytomegalovirus Infection, Dancing Eyes-Dancing Feet Syndrome, Dandy-Walker Syndrome, Dawson Disease, De Morsier's Syndrome, Dejerine-Klumpke Palsy, Dementia - Multi-Infarct, Dementia - Subcortical, Dementia With Lewy Bodies, Dermatomyositis, Developmental Dyspraxia, Devic's Syndrome, Diabetic Neuropathy, Diffuse Sclerosis, Dravet's Syndrome, Dysautonomia,  
30 Dysgraphia, Dyslexia, Dysphagia, Dyspraxia, Dystonias, Early Infantile Epileptic Encephalopathy, Empty Sella Syndrome, Encephalitis Lethargica, Encephalitis and Meningitis, Encephaloceles, Encephalopathy, Encephalotrigeminal Angiomas, Epilepsy, Erb's Palsy, Erb-Duchenne and Dejerine-Klumpke Palsies, Fabry's Disease,

Fahr's Syndrome, Fainting, Familial Dysautonomia, Familial Hemangioma, Familial  
 Idiopathic Basal Ganglia Calcification, Familial Spastic Paralysis, Febrile Seizures (e.g.,  
 GEFS and GEFS plus), Fisher Syndrome, Floppy Infant Syndrome, Friedreich's Ataxia,  
 Gaucher's Disease, Gerstmann's Syndrome, Gerstmann-Straussler-Scheinker Disease,  
 5 Giant Cell Arteritis, Giant Cell Inclusion Disease, Globoid Cell Leukodystrophy,  
 Glossopharyngeal Neuralgia, Guillain-Barre Syndrome, HTLV-1 Associated Myelopathy,  
 Hallervorden-Spatz Disease, Head Injury, Headache, Hemicrania Continua, Hemifacial  
 Spasm, Hemiplegia Alterans, Hereditary Neuropathies, Hereditary Spastic Paraplegia,  
 Heredopathia Atactica Polyneuritiformis, Herpes Zoster Oticus, Herpes Zoster, Hirayama  
 10 Syndrome, Holoprosencephaly, Huntington's Disease, Hydranencephaly, Hydrocephalus -  
 Normal Pressure, Hydrocephalus, Hydromyelia, Hypercortisolism, Hypersomnia,  
 Hypertonia, Hypotonia, Hypoxia, Immune-Mediated Encephalomyelitis, Inclusion Body  
 Myositis, Incontinentia Pigmenti, Infantile Hypotonia, Infantile Phytanic Acid Storage  
 Disease, Infantile Refsum Disease, Infantile Spasms, Inflammatory Myopathy, Intestinal  
 15 Lipodystrophy, Intracranial Cysts, Intracranial Hypertension, Isaac's Syndrome, Joubert  
 Syndrome, Kearns-Sayre Syndrome, Kennedy's Disease, Kinsbourne syndrome,  
 Kleine-Levin syndrome, Klippel Feil Syndrome, Klippel-Trenaunay Syndrome (KTS),  
 Klüver-Bucy Syndrome, Korsakoff's Amnesic Syndrome, Krabbe Disease,  
 Kugelberg-Welander Disease, Kuru, Lambert-Eaton Myasthenic Syndrome,  
 20 Landau-Kleffner Syndrome, Lateral Femoral Cutaneous Nerve Entrapment, Lateral  
 Medullary Syndrome, Learning Disabilities, Leigh's Disease, Lennox-Gastaut Syndrome,  
 Lesch-Nyhan Syndrome, Leukodystrophy, Levine-Critchley Syndrome, Lewy Body  
 Dementia, Lissencephaly, Locked-In Syndrome, Lou Gehrig's Disease, Lupus -  
 Neurological Sequelae, Lyme Disease - Neurological Complications, Machado-Joseph  
 25 Disease, Macrencephaly, Megalencephaly, Melkersson-Rosenthal Syndrome, Meningitis,  
 Menkes Disease, Meralgia Paresthetica, Metachromatic Leukodystrophy, Microcephaly,  
 Migraine, Miller Fisher Syndrome, Mini-Stroke, Mitochondrial Myopathies, Mobius  
 Syndrome, Monomelic Amyotrophy, Motor Neuron Diseases, Moyamoya Disease,  
 Mucopolysaccharidoses, Mucopolysaccharidoses, Multi-Infarct Dementia, Multifocal Motor  
 30 Neuropathy, Multiple Sclerosis, Multiple System Atrophy with Orthostatic Hypotension,  
 Multiple System Atrophy, Muscular Dystrophy, Myasthenia - Congenital, Myasthenia  
 Gravis, Myelinoclastic Diffuse Sclerosis, Myoclonic Encephalopathy of Infants,  
 Myoclonus, Myopathy - Congenital, Myopathy - Thyrotoxic, Myopathy, Myotonia

Congenita, Myotonia, Narcolepsy, Neuroacanthocytosis, Neurodegeneration with Brain Iron Accumulation, Neurofibromatosis, Neuroleptic Malignant Syndrome, Neurological Complications of AIDS, Neurological Manifestations of Pompe Disease, Neuromyelitis Optica, Neuromyotonia, Neuronal Ceroid Lipofuscinosis, Neuronal Migration Disorders, 5 Neuropathy - Hereditary, Neurosarcooidosis, Neurotoxicity, Nevus Cavemosus, Niemann-Pick Disease, O'Sullivan-McLeod Syndrome, Occipital Neuralgia, Occult Spinal Dysraphism Sequence, Ohtahara Syndrome, Olivopontocerebellar Atrophy, Opsoclonus Myoclonus, Orthostatic Hypotension, Overuse Syndrome, Pain - Chronic, Paraneoplastic Syndromes, Paresthesia, Parkinson's Disease, Paromyotonia Congenita, Paroxysmal 10 Choreoathetosis, Paroxysmal Hemicrania, Parry-Romberg, Pelizaeus-Merzbacher Disease, Pena Shokeir II Syndrome, Perineural Cysts, Periodic Paralyzes, Peripheral Neuropathy, Periventricular Leukomalacia, Persistent Vegetative State, Pervasive Developmental Disorders, Phytanic Acid Storage Disease, Pick's Disease, Piriformis Syndrome, Pituitary Tumors, Polymyositis, Pompe Disease, Porencephaly, Post-Polio Syndrome, Postherpetic 15 Neuralgia, Postinfectious Encephalomyelitis, Postural Hypotension, Postural Orthostatic Tachycardia Syndrome, Postural Tachycardia Syndrome, Primary Lateral Sclerosis, Prion Diseases, Progressive Hemifacial Atrophy, Progressive Locomotor Ataxia, Progressive Multifocal Leukoencephalopathy, Progressive Sclerosing Poliodystrophy, Progressive Supranuclear Palsy, Pseudotumor Cerebri, Pyridoxine Dependent and Pyridoxine 20 Responsive Siezure Disorders, Ramsay Hunt Syndrome Type I, Ramsay Hunt Syndrome Type II, Rasmussen's Encephalitis and other autoimmune epilepsies, Reflex Sympathetic Dystrophy Syndrome, Refsum Disease - Infantile, Refsum Disease, Repetitive Motion Disorders, Repetitive Stress Injuries, Restless Legs Syndrome, Retrovirus-Associated Myelopathy, Rett Syndrome, Reye's Syndrome, Riley-Day Syndrome, SUNCT Headache, 25 Sacral Nerve Root Cysts, Saint Vitus Dance, Salivary Gland Disease, Sandhoff Disease, Schilder's Disease, Schizencephaly, Seizure Disorders, Septo-Optic Dysplasia, Severe Myoclonic Epilepsy of Infancy (SMEI), Shaken Baby Syndrome, Shingles, Shy-Drager Syndrome, Sjogren's Syndrome, Sleep Apnea, Sleeping Sickness, Soto's Syndrome, Spasticity, Spina Bifida, Spinal Cord Infarction, Spinal Cord Injury, Spinal Cord Tumors, 30 Spinal Muscular Atrophy, Spinocerebellar Atrophy, Steele-Richardson-Olszewski Syndrome, Stiff-Person Syndrome, Striatonigral Degeneration, Stroke, Sturge-Weber Syndrome, Subacute Sclerosing Panencephalitis, Subcortical Arteriosclerotic Encephalopathy, Swallowing Disorders, Sydenham Chorea, Syncope, Syphilitic Spinal

Sclerosis, Syringohydromyelia, Syringomyelia, Systemic Lupus Erythematosus, Tabes Dorsalis, Tardive Dyskinesia, Tarlov Cysts, Tay-Sachs Disease, Temporal Arteritis, Tethered Spinal Cord Syndrome, Thomsen Disease, Thoracic Outlet Syndrome, Thyrotoxic Myopathy, Tic Douloureux, Todd's Paralysis, Tourette Syndrome, Transient  
5 Ischemic Attack, Transmissible Spongiform Encephalopathies, Transverse Myelitis, Traumatic Brain Injury, Tremor, Trigeminal Neuralgia, Tropical Spastic Paraparesis, Tuberos Sclerosis, Vascular Erectile Tumor, Vasculitis including Temporal Arteritis, Von Economo's Disease, Von Hippel-Lindau disease (VHL), Von Recklinghausen's Disease, Wallenberg's Syndrome, Werdnig-Hoffman Disease, Wernicke-Korsakoff Syndrome,  
10 West Syndrome, Whipple's Disease, Williams Syndrome, Wilson's Disease, X-Linked Spinal and Bulbar Muscular Atrophy, and Zellweger Syndrome.

By "infectious disease" as used herein is meant any disease, condition, trait, genotype or phenotype associated with an infectious agent, such as a virus, bacteria, fungus, prion, or parasite. Non-limiting examples of various viral genes that can be targeted using siNA  
15 molecules of the invention include Hepatitis C Virus (HCV, for example Genbank Accession Nos: D11168, D50483.1, L38318 and S82227), Hepatitis B Virus (HBV, for example GenBank Accession No. AF100308.1), Human Immunodeficiency Virus type 1 (HIV-1, for example GenBank Accession No. U51188), Human Immunodeficiency Virus type 2 (HIV-2, for example GenBank Accession No. X60667), West Nile Virus (WNV for  
20 example GenBank accession No. NC\_001563), cytomegalovirus (CMV for example GenBank Accession No. NC\_001347), respiratory syncytial virus (RSV for example GenBank Accession No. NC\_001781), influenza virus (for example example GenBank Accession No. AF037412, rhinovirus (for example, GenBank accession numbers: D00239, X02316, X01087, L24917, M16248, K02121, X01087), papillomavirus (for example  
25 GenBank Accession No. NC\_001353), Herpes Simplex Virus (HSV for example GenBank Accession No. NC\_001345), and other viruses such as HTLV (for example GenBank Accession No. AJ430458). Due to the high sequence variability of many viral genomes, selection of siRNA molecules for broad therapeutic applications would likely involve the conserved regions of the viral genome. Nonlimiting examples of conserved regions of the  
30 viral genomes include but are not limited to 5'-Non Coding Regions (NCR), 3'- Non Coding Regions (NCR) and/or internal ribosome entry sites (IRES). siRNA molecules designed against conserved regions of various viral genomes will enable efficient

inhibition of viral replication in diverse patient populations and may ensure the effectiveness of the siRNA molecules against viral quasi species which evolve due to mutations in the non-conserved regions of the viral genome. Non-limiting examples of bacterial infections include Actinomycosis, Anthrax, Aspergillosis, Bacteremia, Bacterial  
5 Infections and Mycoses, Bartonella Infections, Botulism, Brucellosis, Burkholderia Infections, Campylobacter Infections, Candidiasis, Cat-Scratch Disease, Chlamydia Infections, Cholera , Clostridium Infections, Coccidioidomycosis, Cross Infection, Cryptococcosis, Dermatormycoses, Dermatormycoses, Diphtheria, Ehrlichiosis, Escherichia coli Infections, Fasciitis, Necrotizing, Fusobacterium Infections, Gas Gangrene,  
10 Gram-Negative Bacterial Infections, Gram-Positive Bacterial Infections, Histoplasmosis, Impetigo, Klebsiella Infections, Legionellosis, Leprosy, Leptospirosis, Listeria Infections, Lyme Disease, Maduromycosis, Melioidosis, Mycobacterium Infections, Mycoplasma Infections, Mycoses, Nocardia Infections, Onychomycosis, Ornithosis, Plague, Pneumococcal Infections, Pseudomonas Infections, Q Fever, Rat-Bite Fever, Relapsing  
15 Fever, Rheumatic Fever, Rickettsia Infections, Rocky Mountain Spotted Fever, Salmonella Infections, Scarlet Fever, Scrub Typhus, Sepsis, Sexually Transmitted Diseases - Bacterial, Bacterial Skin Diseases, Staphylococcal Infections, Streptococcal Infections, Tetanus, Tick-Borne Diseases, Tuberculosis, Tularemia, Typhoid Fever, Typhus, Epidemic Louse-Borne, Vibrio Infections, Yaws, Yersinia Infections, Zoonoses, and Zygomycosis.  
20 Non-limiting examples of fungal infections include Aspergillosis, Blastomycosis, Coccidioidomycosis, Cryptococcosis, Fungal Infections of Fingernails and Toenails, Fungal Sinusitis, Histoplasmosis, Histoplasmosis, Mucormycosis, Nail Fungal Infection, Paracoccidioidomycosis, Sporotrichosis, Valley Fever (Coccidioidomycosis), and Mold Allergy.

25 By "ocular disease" as used herein is meant, any disease, condition, trait, genotype or phenotype of the eye and related structures, such as Cystoid Macular Edema, Asteroid Hyalosis, Pathological Myopia and Posterior Staphyloma, Toxocariasis (Ocular Larva Migrans), Retinal Vein Occlusion, Posterior Vitreous Detachment, Tractional Retinal Tears, Epiretinal Membrane, Diabetic Retinopathy, Lattice Degeneration, Retinal Vein  
30 Occlusion, Retinal Artery Occlusion, Macular Degeneration (e.g., age related macular degeneration such as wet AMD or dry AMD), Toxoplasmosis, Choroidal Melanoma, Acquired Retinoschisis, Hollenhorst Plaque, Idiopathic Central Serous Chorioretinopathy,



Macular Hole, Presumed Ocular Histoplasmosis Syndrome, Retinal Macroaneurysm, Retinitis Pigmentosa, Retinal Detachment, Hypertensive Retinopathy, Retinal Pigment Epithelium (RPE) Detachment, Papillophlebitis, Ocular Ischemic Syndrome, Coats' Disease, Leber's Miliary Aneurysm, Conjunctival Neoplasms, Allergic Conjunctivitis, 5 Vernal Conjunctivitis, Acute Bacterial Conjunctivitis, Allergic Conjunctivitis & Vernal Keratoconjunctivitis, Viral Conjunctivitis, Bacterial Conjunctivitis, Chlamydial & Gonococcal Conjunctivitis, Conjunctival Laceration, Episcleritis, Scleritis, Pingueculitis, Pterygium, Superior Limbic Keratoconjunctivitis (SLK of Theodore), Toxic Conjunctivitis, Conjunctivitis with Pseudomembrane, Giant Papillary Conjunctivitis, Terrien's Marginal 10 Degeneration, Acanthamoeba Keratitis, Fungal Keratitis, Filamentary Keratitis, Bacterial Keratitis, Keratitis Sicca/Dry Eye Syndrome, Bacterial Keratitis, Herpes Simplex Keratitis, Sterile Corneal Infiltrates, Phlyctenulosis, Corneal Abrasion & Recurrent Corneal Erosion, Corneal Foreign Body, Chemical Burs, Epithelial Basement Membrane Dystrophy (EBMD), Thygeson's Superficial Punctate Keratopathy, Corneal Laceration, Salzmann's 15 Nodular Degeneration, Fuchs' Endothelial Dystrophy, Crystalline Lens Subluxation, Ciliary-Block Glaucoma, Primary Open-Angle Glaucoma, Pigment Dispersion Syndrome and Pigmentary Glaucoma, Pseudoexfoliation Syndrome and Pseudoexfoliative Glaucoma, Anterior Uveitis, Primary Open Angle Glaucoma, Uveitic Glaucoma & Glaucomatocyclitic Crisis, Pigment Dispersion Syndrome & Pigmentary Glaucoma, Acute 20 Angle Closure Glaucoma, Anterior Uveitis, Hyphema, Angle Recession Glaucoma, Lens Induced Glaucoma, Pseudoexfoliation Syndrome and Pseudoexfoliative Glaucoma, Axenfeld-Rieger Syndrome, Neovascular Glaucoma, Pars Planitis, Choroidal Rupture, Duane's Retraction Syndrome, Toxic/Nutritional Optic Neuropathy, Aberrant Regeneration of Cranial Nerve III, Intracranial Mass Lesions, Carotid-Cavernous Sinus 25 Fistula, Anterior Ischemic Optic Neuropathy, Optic Disc Edema & Papilledema, Cranial Nerve III Palsy, Cranial Nerve IV Palsy, Cranial Nerve VI Palsy, Cranial Nerve VII (Facial Nerve) Palsy, Horner's Syndrome, Internuclear Ophthalmoplegia, Optic Nerve Head Hypoplasia, Optic Pit, Tonic Pupil, Optic Nerve Head Drusen, Demyelinating Optic Neuropathy (Optic Neuritis, Retrobulbar Optic Neuritis), Amaurosis Fugax and Transient 30 Ischemic Attack, Pseudotumor Cerebri, Pituitary Adenoma, Molluscum Contagiosum, Canaliculitis, Verruca and Papilloma, Pediculosis and Pthiriasis, Blepharitis, Hordeolum, Preseptal Cellulitis, Chalazion, Basal Cell Carcinoma, Herpes Zoster Ophthalmicus,

Pediculosis & Phthiriasis, Blow-out Fracture, Chronic Epiphora, Dacryocystitis, Herpes Simplex Blepharitis, Orbital Cellulitis, Senile Entropion, and Squamous Cell Carcinoma.

In one embodiment of the present invention, each sequence of a siNA molecule of the invention is independently about 18 to about 24 nucleotides in length, in specific  
5 embodiments about 18, 19, 20, 21, 22, 23, or 24 nucleotides in length. In another embodiment, the siNA duplexes of the invention independently comprise about 17 to about 23 base pairs (*e.g.*, about 17, 18, 19, 20, 21, 22 or 23). In yet another embodiment, siNA molecules of the invention comprising hairpin or circular structures are about 35 to about 55 (*e.g.*, about 35, 40, 45, 50 or 55) nucleotides in length, or about 38 to about 44 (*e.g.*, 38,  
10 39, 40, 41, 42, 43 or 44) nucleotides in length and comprising about 16 to about 22 (*e.g.*, about 16, 17, 18, 19, 20, 21 or 22) base pairs. Exemplary siNA molecules of the invention are shown in **Table I.** and/or **Figures 18-19.**

As used herein "cell" is used in its usual biological sense, and does not refer to an entire multicellular organism, *e.g.*, specifically does not refer to a human. The cell can be  
15 present in an organism, *e.g.*, birds, plants and mammals such as humans, cows, sheep, apes, monkeys, swine, dogs, and cats. The cell can be prokaryotic (*e.g.*, bacterial cell) or eukaryotic (*e.g.*, mammalian or plant cell). The cell can be of somatic or germ line origin, totipotent or pluripotent, dividing or non-dividing. The cell can also be derived from or can comprise a gamete or embryo, a stem cell, or a fully differentiated cell.

20 The siNA molecules of the invention are added directly, or can be complexed with cationic lipids, packaged within liposomes, or otherwise delivered to target cells or tissues. The nucleic acid or nucleic acid complexes can be locally administered to relevant tissues *ex vivo*, or *in vivo* through injection, infusion pump or stent, with or without their incorporation in biopolymers. In particular embodiments, the nucleic acid molecules of the  
25 invention comprise sequences shown in **Table I** and/or **Figures 18-19.** Examples of such nucleic acid molecules consist essentially of sequences defined in these tables and figures. Furthermore, the chemically modified constructs described in **Table IV** can be applied to any siNA sequence of the invention.

In another aspect, the invention provides mammalian cells containing one or more  
30 siNA molecules of this invention. The one or more siNA molecules can independently be targeted to the same or different sites.

By "RNA" is meant a molecule comprising at least one ribonucleotide residue. By "ribonucleotide" is meant a nucleotide with a hydroxyl group at the 2' position of a  $\beta$ -D-ribo-furanose moiety. The terms include double-stranded RNA, single-stranded RNA, isolated RNA such as partially purified RNA, essentially pure RNA, synthetic RNA, recombinantly produced RNA, as well as altered RNA that differs from naturally occurring RNA by the addition, deletion, substitution and/or alteration of one or more nucleotides. Such alterations can include addition of non-nucleotide material, such as to the end(s) of the siNA or internally, for example at one or more nucleotides of the RNA. Nucleotides in the RNA molecules of the instant invention can also comprise non-standard nucleotides, such as non-naturally occurring nucleotides or chemically synthesized nucleotides or deoxynucleotides. These altered RNAs can be referred to as analogs or analogs of naturally-occurring RNA.

By "subject" is meant an organism, which is a donor or recipient of explanted cells or the cells themselves. "Subject" also refers to an organism to which the nucleic acid molecules of the invention can be administered. A subject can be a mammal or mammalian cells, including a human or human cells.

The term "ligand" refers to any compound or molecule, such as a drug, peptide, hormone, or neurotransmitter, that is capable of interacting with another compound, such as a receptor, either directly or indirectly. The receptor that interacts with a ligand can be present on the surface of a cell or can alternately be an intercellular receptor. Interaction of the ligand with the receptor can result in a biochemical reaction, or can simply be a physical interaction or association.

The term "phosphorothioate" as used herein refers to an internucleotide linkage having Formula I, wherein Z and/or W comprise a sulfur atom. Hence, the term phosphorothioate refers to both phosphorothioate and phosphorodithioate internucleotide linkages.

The term "phosphonoacetate" as used herein refers to an internucleotide linkage having Formula I, wherein Z and/or W comprise an acetyl or protected acetyl group.

The term "thiophosphonoacetate" as used herein refers to an internucleotide linkage having Formula I, wherein Z comprises an acetyl or protected acetyl group and W

comprises a sulfur atom or alternately W comprises an acetyl or protected acetyl group and Z comprises a sulfur atom.

The term "universal base" as used herein refers to nucleotide base analogs that form base pairs with each of the natural DNA/RNA bases with little discrimination between  
5 them. Non-limiting examples of universal bases include C-phenyl, C-naphthyl and other aromatic derivatives, inosine, azole carboxamides, and nitroazole derivatives such as 3-nitropyrrrole, 4-nitroindole, 5-nitroindole, and 6-nitroindole as known in the art (see for example Loakes, 2001, *Nucleic Acids Research*, 29, 2437-2447).

The term "acyclic nucleotide" as used herein refers to any nucleotide having an  
10 acyclic ribose sugar, for example where any of the ribose carbons (C1, C2, C3, C4, or C5), are independently or in combination absent from the nucleotide.

The nucleic acid molecules of the instant invention, individually, or in combination or in conjunction with other drugs, can be used to treat diseases or conditions discussed herein (e.g., cancers and othe proliferative conditions, viral infection, inflammatory disease,  
15 autoimmunity, pulmonary disease, renal disease, ocular disease, etc.). For example, to treat a particular disease, condition, trait, genotype or phenotype, the siNA molecules can be administered to a subject or can be administered to other appropriate cells evident to those skilled in the art, individually or in combination with one or more drugs under conditions suitable for the treatment.

20 In one embodiment, the invention features a method for treating or preventing a disease, condition, trait, genotype or phenotype in a subject, wherein the disease, condition, trait, genotype or phenotype is related to angiogenesis or neovascularization, comprising administering to the subject a siNA molecule of the invention under conditions suitable for the treatment or prevention of the disease, condition, trait, genotype or phenotype in the  
25 subject, alone or in conjunction with one or more other therapeutic compounds. In another embodiment, the disease, condition, trait, genotype or phenotype comprises tumor angiogenesis and cancerous conditions herein, including but not limited to breast cancer, lung cancer (including non-small cell lung carcinoma), prostate cancer, colorectal cancer, brain cancer, esophageal cancer, bladder cancer, pancreatic cancer, cervical cancer, head  
30 and neck cancer, skin cancers, nasopharyngeal carcinoma, liposarcoma, epithelial carcinoma, renal cell carcinoma, gallbladder adeno carcinoma, parotid adenocarcinoma,

ovarian cancer, melanoma, lymphoma, glioma, endometrial sarcoma, multidrug resistant cancers, diabetic retinopathy, macular degeneration, age related macular degeneration, neovascular glaucoma, myopic degeneration, arthritis, psoriasis, endometriosis, female reproduction, verruca vulgaris, angiofibroma of tuberous sclerosis, pot-wine stains, Sturge  
5 Weber syndrome, Kippel-Trenaunay-Weber syndrome, Osler-Weber-Rendu syndrome, renal disease such as Autosomal dominant polycystic kidney disease (ADPKD), restenosis, arteriosclerosis, and any other diseases or conditions that are related to gene expression or will respond to RNA interference in a cell or tissue, alone or in combination with other therapies.

10 In one embodiment, the invention features a method for treating or preventing an ocular disease, condition, trait, genotype or phenotype in a subject, wherein the ocular disease, condition, trait, genotype or phenotype is related to angiogenesis or neovascularization, comprising administering to the subject a siNA molecule of the invention under conditions suitable for the treatment or prevention of the disease, condition,  
15 trait, genotype or phenotype in the subject, alone or in conjunction with one or more other therapeutic compounds. In another embodiment, the ocular disease, condition, trait, genotype or phenotype comprises macular degeneration, age related macular degeneration, diabetic retinopathy, neovascular glaucoma, myopic degeneration, trachoma, scarring of the eye, cataract, ocular inflammation and/or ocular infections.

20 In one embodiment, the invention features a method for treating or preventing tumor angiogenesis in a subject, comprising administering to the subject a siNA molecule of the invention under conditions suitable for the treatment or prevention of tumor angiogenesis in the subject, alone or in conjunction with one or more other therapeutic compounds.

25 In one embodiment, the invention features a method for treating or preventing viral infection or replication in a subject, comprising administering to the subject a siNA molecule of the invention under conditions suitable for the treatment or prevention of viral infection or replication in the subject, alone or in conjunction with one or more other therapeutic compounds.

30 In one embodiment, the invention features a method for treating or preventing autoimmune disease in a subject, comprising administering to the subject a siNA molecule of the invention under conditions suitable for the treatment or prevention of autoimmune

disease in the subject, alone or in conjunction with one or more other therapeutic compounds.

In one embodiment, the invention features a method for treating or preventing inflammation in a subject, comprising administering to the subject a siNA molecule of the invention under conditions suitable for the treatment or prevention of inflammation in the  
5 subject, alone or in conjunction with one or more other therapeutic compounds.

In a further embodiment, the siNA molecules can be used in combination with other known treatments to treat conditions or diseases discussed above. For example, the described molecules could be used in combination with one or more known therapeutic  
10 agents to treat a disease, condition, trait, genotype or phenotype. Non-limiting examples of other therapeutic agents that can be readily combined with a siNA molecule of the invention are enzymatic nucleic acid molecules, allosteric nucleic acid molecules, antisense, decoy, or aptamer nucleic acid molecules, antibodies such as monoclonal antibodies, small molecules, and other organic and/or inorganic compounds including  
15 metals, salts and ions.

In one embodiment, the invention features a method for treating or preventing a disease or condition in a subject, wherein the disease or condition is related to angiogenesis or neovascularization, comprising administering to the subject a siNA molecule of the invention under conditions suitable for the treatment or prevention of the disease or  
20 condition in the subject, alone or in conjunction with one or more other therapeutic compounds. In another embodiment, the disease or condition resulting from angiogenesis, such as tumor angiogenesis leading to cancer, such as without limitation to breast cancer, lung cancer (including non-small cell lung carcinoma), prostate cancer, colorectal cancer, brain cancer, esophageal cancer, bladder cancer, pancreatic cancer, cervical cancer, head  
25 and neck cancer, skin cancers, nasopharyngeal carcinoma, liposarcoma, epithelial carcinoma, renal cell carcinoma, gallbladder adeno carcinoma, parotid adenocarcinoma, ovarian cancer, melanoma, lymphoma, glioma, endometrial sarcoma, and multidrug resistant cancers, diabetic retinopathy, macular degeneration, age related macular degeneration, macular adema, neovascular glaucoma, myopic degeneration, arthritis,  
30 psoriasis, endometriosis, female reproduction, verruca vulgaris, angiofibroma of tuberous sclerosis, pot-wine stains, Sturge Weber syndrome, Kippel-Trenaunay-Weber syndrome,

Osler-Weber-Rendu syndrome, renal disease such as Autosomal dominant polycystic kidney disease (ADPKD), restenosis, arteriosclerosis, and any other diseases or conditions that are related to gene expression or will respond to RNA interference in a cell or tissue, alone or in combination with other therapies.

5           In one embodiment, the invention features a method for treating or preventing an ocular disease or condition in a subject, wherein the ocular disease or condition is related to angiogenesis or neovascularization (such as those involving genes in the vascular endothelial growth factor, VEGF pathway or TGF-beta pathway), comprising administering to the subject a siNA molecule of the invention under conditions suitable for  
10 the treatment or prevention of the disease or condition in the subject, alone or in conjunction with one or more other therapeutic compounds. In another embodiment, the ocular disease or condition comprises macular degeneration, age related macular degeneration, diabetic retinopathy, macular adema, neovascular glaucoma, myopic degeneration, trachoma, scarring of the eye, cataract, ocular inflammation and/or ocular  
15 infections.

          In one embodiment, the invention features a method of locally administering (e.g., by injection, such as intraocular, intratumoral, periocular, intracranial, etc., topical administration, catheter or the like) to a tissue or cell (e.g., ocular or retinal, brain, CNS) a siNA molecule or a vector expressing siNA molecule, comprising nucleotide sequence that  
20 is complementary to nucleotide sequence of target RNA, or a portion thereof, (e.g., target RNA encoding VEGF or a VEGF receptor) comprising contacting said tissue of cell with said double stranded RNA under conditions suitable for said local administration.

          In one embodiment, the invention features a method of topically administering (e.g., by dermal, transdermal, hair follicle administration etc.,) to a tissue, organ or cell (e.g., skin, hair follicle) a siNA molecule or a vector expressing siNA molecule, comprising nucleotide  
25 sequence that is complementary to nucleotide sequence of target RNA, or a portion thereof, expressed in such organ, cell or tissue (e.g., hairless gene, 5-alpha reductase, nude gene, desmoglein 4 gene, TGF-beta, PDGF, BCL-2 and the like) comprising contacting said tissue of cell with said double stranded RNA under conditions suitable for said topical  
30 administration. Such topical administration can be used to treat dermatological disease, indication, conditions, trait, genotype or phenotype, or for cosmetic applications such as

acne, psoriasis, melanoma, alopecia, hair removal etc. In one embodiment, the invention features a method of systemically administering (e.g., by injection, such as subcutaneous, intravenous, topical administration, or the like) to a tissue or cell in a subject, a double stranded RNA formed by a siNA molecule or a vector expressing siNA molecule  
5 comprising nucleotide sequence that is complementary to nucleotide sequence of target RNA, or a portion thereof, (e.g., target RNA encoding VEGF or a VEGF receptor) comprising contacting said subject with said double stranded RNA under conditions suitable for said systemic administration.

In one embodiment, the invention features a method for treating or preventing tumor  
10 angiogenesis in a subject comprising administering to the subject a siNA molecule of the invention under conditions suitable for the treatment or prevention of tumor angiogenesis in the subject, alone or in conjunction with one or more other therapeutic compounds.

In one embodiment, the invention features a method for treating or preventing viral  
15 infection or replication in a subject comprising administering to the subject a siNA molecule of the invention under conditions suitable for the treatment or prevention of viral infection or replication in the subject, alone or in conjunction with one or more other therapeutic compounds.

In one embodiment, the invention features a method for treating or preventing  
20 autoimmune disease in a subject comprising administering to the subject a siNA molecule of the invention under conditions suitable for the treatment or prevention of autoimmune disease in the subject, alone or in conjunction with one or more other therapeutic compounds.

In one embodiment, the invention features a method for treating or preventing  
25 neurologic disease (e.g., Alzheimer's disease, Huntington disease, Parkinson disease, ALS, multiple sclerosis, epilepsy, etc.) in a subject comprising administering to the subject a siNA molecule of the invention under conditions suitable for the treatment or prevention of neurologic disease in the subject, alone or in conjunction with one or more other therapeutic compounds.

In one embodiment, the invention features a method for treating or preventing  
30 inflammation in a subject comprising administering to the subject a siNA molecule of the



invention under conditions suitable for the treatment or prevention of inflammation in the subject, alone or in conjunction with one or more other therapeutic compounds.

Other features and advantages of the invention will be apparent from the following description of the preferred embodiments thereof, and from the claims.

5

### BRIEF DESCRIPTION OF THE DRAWINGS

**Figure 1** shows a non-limiting example of a scheme for the synthesis of siNA molecules. The complementary siNA sequence strands, strand 1 and strand 2, are synthesized in tandem and are connected by a cleavable linkage, such as a nucleotide succinate or abasic succinate, which can be the same or different from the cleavable linker used for solid phase synthesis on a solid support. The synthesis can be either solid phase or solution phase, in the example shown, the synthesis is a solid phase synthesis. The synthesis is performed such that a protecting group, such as a dimethoxytrityl group, remains intact on the terminal nucleotide of the tandem oligonucleotide. Upon cleavage and deprotection of the oligonucleotide, the two siNA strands spontaneously hybridize to form a siNA duplex, which allows the purification of the duplex by utilizing the properties of the terminal protecting group, for example by applying a trityl on purification method wherein only duplexes/oligonucleotides with the terminal protecting group are isolated.

**Figure 2** shows a MALDI-TOF mass spectrum of a purified siNA duplex synthesized by a method of the invention. The two peaks shown correspond to the predicted mass of the separate siNA sequence strands. This result demonstrates that the siNA duplex generated from tandem synthesis can be purified as a single entity using a simple trityl-on purification methodology.

**Figure 3** shows the results of a stability assay used to determine the serum stability of chemically modified siNA constructs compared to a siNA control consisting of all RNA with 3'-TT termini.  $T_{1/2}$  values are shown for duplex stability.

**Figure 4** shows the results of an RNAi activity screen of several phosphorothioate modified siNA constructs using a luciferase reporter system.

**Figure 5** shows the results of an RNAi activity screen of several phosphorothioate and universal base modified siNA constructs using a luciferase reporter system.

**Figure 6** shows the results of an RNAi activity screen of several 2'-O-methyl modified siNA constructs using a luciferase reporter system.

**Figure 7** shows the results of an RNAi activity screen of several 2'-O-methyl and 2'-deoxy-2'-fluoro modified siNA constructs using a luciferase reporter system.

5 **Figure 8** shows the results of an RNAi activity screen of a phosphorothioate modified siNA construct using a luciferase reporter system.

**Figure 9** shows the results of an RNAi activity screen of an inverted deoxybasic modified siNA construct generated via tandem synthesis using a luciferase reporter system.

**Figure 10** shows the results of an RNAi activity screen of chemically modified siNA  
10 constructs including 3'-glyceryl modified siNA constructs compared to an all RNA control  
siNA construct using a luciferase reporter system. These chemically modified siNAs were  
compared in the luciferase assay described herein at 1 nM and 10nM concentration using  
an all RNA siNA control (siGL2) having 3'-terminal dithymidine (TT) and its  
corresponding inverted control (Inv siGL2). The background level of luciferase expression  
15 in the HeLa cells is designated by the "cells" column. Sense and antisense strands of  
chemically modified siNA constructs are shown by Sirna/RPI number (sense  
strand/antisense strand). Sequences corresponding to these Sirna/RPI numbers are shown  
in Table I.

**Figure 11** shows the results of an RNAi activity screen of chemically modified siNA  
20 constructs. The screen compared various combinations of sense strand chemical  
modifications and antisense strand chemical modifications. These chemically modified  
siNAs were compared in the luciferase assay described herein at 1 nM and 10nM  
concentration using an all RNA siNA control (siGL2) having 3'-terminal dithymidine (TT)  
and its corresponding inverted control (Inv siGL2). The background level of luciferase  
25 expression in the HeLa cells is designated by the "cells" column. Sense and antisense  
strands of chemically modified siNA constructs are shown by Sirna/RPI number (sense  
strand/antisense strand). Sequences corresponding to these Sirna/RPI numbers are shown  
in Table I.

**Figure 12** shows the results of an RNAi activity screen of chemically modified siNA constructs. The screen compared various combinations of sense strand chemical modifications and antisense strand chemical modifications. These chemically modified siNAs were compared in the luciferase assay described herein at 1 nM and 10nM concentration using an all RNA siNA control (siGL2) having 3'-terminal dithymidine (TT) and its corresponding inverted control (Inv siGL2). The background level of luciferase expression in the HeLa cells is designated by the "cells" column. Sense and antisense strands of chemically modified siNA constructs are shown by Sirna/RPI number (sense strand/antisense strand). Sequences corresponding to these Sirna/RPI numbers are shown in Table I. In addition, the antisense strand alone (Sirna/RPI 30430) and an inverted control (Sirna/RPI 30227/30229, having matched chemistry to Sirna/RPI (30063/30224) was compared to the siNA duplexes described above.

**Figure 13** shows the results of an RNAi activity screen of chemically modified siNA constructs. The screen compared various combinations of sense strand chemical modifications and antisense strand chemical modifications. These chemically modified siNAs were compared in the luciferase assay described herein at 1 nM and 10nM concentration using an all RNA siNA control (siGL2) having 3'-terminal dithymidine (TT) and its corresponding inverted control (Inv siGL2). The background level of luciferase expression in the HeLa cells is designated by the "cells" column. Sense and antisense strands of chemically modified siNA constructs are shown by Sirna/RPI number (sense strand/antisense strand). Sequences corresponding to these Sirna/RPI numbers are shown in Table I. In addition, an inverted control (Sirna/RPI 30226/30229), having matched chemistry to Sirna/RPI (30222/30224) was compared to the siNA duplexes described above.

**Figure 14** shows the results of an RNAi activity screen of chemically modified siNA constructs including various 3'-terminal modified siNA constructs compared to an all RNA control siNA construct using a luciferase reporter system. These chemically modified siNAs were compared in the luciferase assay described herein at 1 nM and 10nM concentration using an all RNA siNA control (siGL2) having 3'-terminal dithymidine (TT) and its corresponding inverted control (Inv siGL2). The background level of luciferase expression in the HeLa cells is designated by the "cells" column. Sense and antisense strands of chemically modified siNA constructs are shown by Sirna/RPI number (sense

strand/antisense strand). Sequences corresponding to these Sirna/RPI numbers are shown in Table I.

**Figure 15** shows the results of an RNAi activity screen of chemically modified siNA constructs. The screen compared various combinations of sense strand chemistries compared to a fixed antisense strand chemistry. These chemically modified siNAs were compared in the luciferase assay described herein at 1 nM and 10nM concentration using an all RNA siNA control (siGL2) having 3'-terminal dithymidine (TT) and its corresponding inverted control (Inv siGL2). The background level of luciferase expression in the HeLa cells is designated by the "cells" column. Sense and antisense strands of chemically modified siNA constructs are shown by Sirna/RPI number (sense strand/antisense strand). Sequences corresponding to these Sirna/RPI numbers are shown in Table I.

**Figure 16** shows the results of a siNA titration study using a luciferase reporter system, wherein the RNAi activity of a phosphorothioate modified siNA construct is compared to that of a siNA construct consisting of all ribonucleotides except for two terminal thymidine residues.

**Figure 17** shows a non-limiting proposed mechanistic representation of target RNA degradation involved in RNAi. Double-stranded RNA (dsRNA), which is generated by RNA-dependent RNA polymerase (RdRP) from foreign single-stranded RNA, for example viral, transposon, or other exogenous RNA, activates the DICER enzyme that in turn generates siNA duplexes. Alternately, synthetic or expressed siNA can be introduced directly into a cell by appropriate means. An active siNA complex forms which recognizes a target RNA, resulting in degradation of the target RNA by the RISC endonuclease complex or in the synthesis of additional RNA by RNA-dependent RNA polymerase (RdRP), which can activate DICER and result in additional siNA molecules, thereby amplifying the RNAi response.

**Figure 18A-F** shows non-limiting examples of chemically-modified siNA constructs of the present invention. In the figure, N stands for any nucleotide (adenosine, guanosine, cytosine, uridine, or optionally thymidine, for example thymidine can be substituted in the overhanging regions designated by parenthesis (N N). Various modifications are shown for the sense and antisense strands of the siNA constructs.

**Figure 18A:** The sense strand comprises 21 nucleotides wherein the two terminal 3'-nucleotides are optionally base paired and wherein all nucleotides present are ribonucleotides except for (N N) nucleotides, which can comprise ribonucleotides, deoxynucleotides, universal bases, or other chemical modifications described herein. The antisense strand comprises 21 nucleotides, optionally having a 3'-terminal glyceryl moiety wherein the two terminal 3'-nucleotides are optionally complementary to the target RNA sequence, and wherein all nucleotides present are ribonucleotides except for (N N) nucleotides, which can comprise ribonucleotides, deoxynucleotides, universal bases, or other chemical modifications described herein. A modified internucleotide linkage, such as a phosphorothioate, phosphorodithioate or other modified internucleotide linkage as described herein, shown as "s", optionally connects the (N N) nucleotides in the antisense strand.

**Figure 18B:** The sense strand comprises 21 nucleotides wherein the two terminal 3'-nucleotides are optionally base paired and wherein all pyrimidine nucleotides that may be present are 2'-deoxy-2'-fluoro modified nucleotides and all purine nucleotides that may be present are 2'-O-methyl modified nucleotides except for (N N) nucleotides, which can comprise ribonucleotides, deoxynucleotides, universal bases, or other chemical modifications described herein. The antisense strand comprises 21 nucleotides, optionally having a 3'-terminal glyceryl moiety and wherein the two terminal 3'-nucleotides are optionally complementary to the target RNA sequence, and wherein all pyrimidine nucleotides that may be present are 2'-deoxy-2'-fluoro modified nucleotides and all purine nucleotides that may be present are 2'-O-methyl modified nucleotides except for (N N) nucleotides, which can comprise ribonucleotides, deoxynucleotides, universal bases, or other chemical modifications described herein. A modified internucleotide linkage, such as a phosphorothioate, phosphorodithioate or other modified internucleotide linkage as described herein, shown as "s", optionally connects the (N N) nucleotides in the sense and antisense strand.

**Figure 18C:** The sense strand comprises 21 nucleotides having 5'- and 3'- terminal cap moieties wherein the two terminal 3'-nucleotides are optionally base paired and wherein all pyrimidine nucleotides that may be present are 2'-O-methyl or 2'-deoxy-2'-fluoro modified nucleotides except for (N N) nucleotides, which can comprise ribonucleotides, deoxynucleotides, universal bases, or other chemical modifications

described herein. The antisense strand comprises 21 nucleotides, optionally having a 3'-terminal glyceryl moiety and wherein the two terminal 3'-nucleotides are optionally complementary to the target RNA sequence, and wherein all pyrimidine nucleotides that may be present are 2'-deoxy-2'-fluoro modified nucleotides except for (N N) nucleotides, which can comprise ribonucleotides, deoxynucleotides, universal bases, or other chemical modifications described herein. A modified internucleotide linkage, such as a phosphorothioate, phosphorodithioate or other modified internucleotide linkage as described herein, shown as "s", optionally connects the (N N) nucleotides in the antisense strand.

10 **Figure 18D:** The sense strand comprises 21 nucleotides having 5'- and 3'- terminal cap moieties wherein the two terminal 3'-nucleotides are optionally base paired and wherein all pyrimidine nucleotides that may be present are 2'-deoxy-2'-fluoro modified nucleotides except for (N N) nucleotides, which can comprise ribonucleotides, deoxynucleotides, universal bases, or other chemical modifications described herein and  
15 wherein and all purine nucleotides that may be present are 2'-deoxy nucleotides. The antisense strand comprises 21 nucleotides, optionally having a 3'-terminal glyceryl moiety and wherein the two terminal 3'-nucleotides are optionally complementary to the target RNA sequence, wherein all pyrimidine nucleotides that may be present are 2'-deoxy-2'-fluoro modified nucleotides and all purine nucleotides that may be present are  
20 2'-O-methyl modified nucleotides except for (N N) nucleotides, which can comprise ribonucleotides, deoxynucleotides, universal bases, or other chemical modifications described herein. A modified internucleotide linkage, such as a phosphorothioate, phosphorodithioate or other modified internucleotide linkage as described herein, shown as "s", optionally connects the (N N) nucleotides in the antisense strand.

25 **Figure 18E:** The sense strand comprises 21 nucleotides having 5'- and 3'- terminal cap moieties wherein the two terminal 3'-nucleotides are optionally base paired and wherein all pyrimidine nucleotides that may be present are 2'-deoxy-2'-fluoro modified nucleotides except for (N N) nucleotides, which can comprise ribonucleotides, deoxynucleotides, universal bases, or other chemical modifications described herein. The  
30 antisense strand comprises 21 nucleotides, optionally having a 3'-terminal glyceryl moiety and wherein the two terminal 3'-nucleotides are optionally complementary to the target RNA sequence, and wherein all pyrimidine nucleotides that may be present are

2'-deoxy-2'-fluoro modified nucleotides and all purine nucleotides that may be present are 2'-O-methyl modified nucleotides except for (N N) nucleotides, which can comprise ribonucleotides, deoxynucleotides, universal bases, or other chemical modifications described herein. A modified internucleotide linkage, such as a phosphorothioate, 5 phosphorodithioate or other modified internucleotide linkage as described herein, shown as "s", optionally connects the (N N) nucleotides in the antisense strand.

**Figure 18F:** The sense strand comprises 21 nucleotides having 5'- and 3'- terminal cap moieties wherein the two terminal 3'-nucleotides are optionally base paired and wherein all pyrimidine nucleotides that may be present are 2'-deoxy-2'-fluoro modified 10 nucleotides except for (N N) nucleotides, which can comprise ribonucleotides, deoxynucleotides, universal bases, or other chemical modifications described herein and wherein and all purine nucleotides that may be present are 2'-deoxy nucleotides. The antisense strand comprises 21 nucleotides, optionally having a 3'-terminal glyceryl moiety and wherein the two terminal 3'-nucleotides are optionally complementary to the target 15 RNA sequence, and having one 3'-terminal phosphorothioate internucleotide linkage and wherein all pyrimidine nucleotides that may be present are 2'-deoxy-2'-fluoro modified nucleotides and all purine nucleotides that may be present are 2'-deoxy nucleotides except for (N N) nucleotides, which can comprise ribonucleotides, deoxynucleotides, universal bases, or other chemical modifications described herein. A modified internucleotide 20 linkage, such as a phosphorothioate, phosphorodithioate or other modified internucleotide linkage as described herein, shown as "s", optionally connects the (N N) nucleotides in the antisense strand. The antisense strand of constructs A-F comprise sequence complementary to any target nucleic acid sequence of the invention. Furthermore, when a glyceryl moiety (L) is present at the 3'-end of the antisense strand for any construct shown 25 in Figure 4 A-F, the modified internucleotide linkage is optional.

**Figure 19** shows non-limiting examples of specific chemically modified siNA sequences of the invention. A-F applies the chemical modifications described in **Figure 18A-F** to a representative siNA sequence targeting the hepatitis C virus (HCV). However, such chemical modifications can be applied to any target sequence contemplated by the 30 instant invention (see for example target sequences referred to by accession number in McSwiggen et al., International PCT publication No. WO 03/74654).

**Figure 20** shows non-limiting examples of different siNA constructs of the invention. The examples shown (constructs 1, 2, and 3) have 19 representative base pairs; however, different embodiments of the invention include any number of base pairs described herein. Bracketed regions represent nucleotide overhangs, for example comprising about 1, 2, 3, or 4 nucleotides in length when present, preferably about 2 nucleotides. Such overhangs can be present or absent (i.e., blunt ends). Such blunt ends can be present on one end or both ends of the siNA molecule, for example where all nucleotides present in a siNA duplex are base paired. Constructs 1 and 2 can be used independently for RNAi activity. Construct 2 can comprise a polynucleotide or non-nucleotide linker, which can optionally be designed as a biodegradable linker. In one embodiment, the loop structure shown in construct 2 can comprise a biodegradable linker that results in the formation of construct 1 *in vivo* and/or *in vitro*. In another example, construct 3 can be used to generate construct 2 under the same principle wherein a linker is used to generate the active siNA construct 2 *in vivo* and/or *in vitro*, which can optionally utilize another biodegradable linker to generate the active siNA construct 1 *in vivo* and/or *in vitro*. As such, the stability and/or activity of the siNA constructs can be modulated based on the design of the siNA construct for use *in vivo* or *in vitro* and/or *in vitro*.

**Figure 21** is a diagrammatic representation of a method used to determine target sites for siNA mediated RNAi within a particular target nucleic acid sequence, such as messenger RNA. (A) A pool of siNA oligonucleotides are synthesized wherein the antisense region of the siNA constructs has complementarity to target sites across the target nucleic acid sequence, and wherein the sense region comprises sequence complementary to the antisense region of the siNA. (B) The sequences are transfected into cells. (C) Cells are selected based on phenotypic change that is associated with modulation of the target nucleic acid sequence. (D) The siNA is isolated from the selected cells and is sequenced to identify efficacious target sites within the target nucleic acid sequence.

**Figure 22** shows non-limiting examples of different stabilization chemistries (1-10) that can be used, for example, to stabilize the 3'-end of siNA sequences of the invention, including (1) [3'-3']-inverted deoxyribose; (2) deoxyribonucleotide; (3) [5'-3']-3'-deoxyribonucleotide; (4) [5'-3']-ribonucleotide; (5) [5'-3']-3'-O-methyl ribonucleotide; (6) 3'-glyceryl; (7) [3'-5']-3'-deoxyribonucleotide; (8) [3'-3']-deoxyribonucleotide; (9) [5'-2']-deoxyribonucleotide; and (10)



[5-3']-dideoxyribonucleotide. In addition to modified and unmodified backbone chemistries indicated in the figure, these chemistries can be combined with different backbone modifications as described herein, for example, backbone modifications having Formula I. In addition, the 2'-deoxy nucleotide shown 5' to the terminal modifications shown can be another modified or unmodified nucleotide or non-nucleotide described herein, for example modifications having any of Formulae I-VII or any combination thereof.

**Figure 23** shows a non-limiting example of siNA mediated inhibition of VEGF-induced angiogenesis using the rat corneal model of angiogenesis. siNA targeting site 2340 of VEGFR1 RNA (shown as Sirna/RPI No. 29695/29699) were compared to inverted controls (shown as Sirna/RPI No. 29983/29984) at three different concentrations and compared to a VEGF control in which no siNA was administered.

**Figure 24** is a non-limiting example of a HBsAg screen of stabilized siNA constructs ("stab 4/5", see **Table IV**) targeting HBV pregenomic RNA in HepG2 cells at 25 nM compared to untreated and matched chemistry inverted sequence controls. The siNA sense and antisense strands are shown by Sirna/RPI number (sense/antisense).

**Figure 25** is a non-limiting example of a dose response HBsAg screen of stabilized siNA constructs ("stab 4/5", see **Table IV**) targeting sites 262 and 1580 of the HBV pregenomic RNA in HepG2 cells at 0.5, 5, 10 and 25 nM compared to untreated and matched chemistry inverted sequence controls. The siNA sense and antisense strands are shown by Sirna/RPI number (sense/antisense).

**Figure 26** shows a dose response comparison of two different stabilization chemistries ("stab 7/8" and "stab 7/11", see **Table IV**) targeting site 1580 of the HBV pregenomic RNA in HepG2 cells at 5, 10, 25, 50 and 100 nM compared to untreated and matched chemistry inverted sequence controls. The siNA sense and antisense strands are shown by Sirna/RPI number (sense/antisense).

**Figure 27** shows a non-limiting example of a strategy used to identify chemically modified siNA constructs of the invention that are nuclease resistance while preserving the ability to mediate RNAi activity. Chemical modifications are introduced into the siNA construct based on educated design parameters (e.g., introducing 2'-modifications, base

modifications, backbone modifications, terminal cap modifications etc). The modified construct is tested in an appropriate system (e.g human serum for nuclease resistance, shown, or an animal model for PK/delivery parameters). In parallel, the siNA construct is tested for RNAi activity, for example in a cell culture system such as a luciferase reporter assay). Lead siNA constructs are then identified which possess a particular characteristic while maintaining RNAi activity, and can be further modified and assayed once again. This same approach can be used to identify siNA-conjugate molecules with improved pharmacokinetic profiles, delivery, and RNAi activity.

**Figure 28** shows representative data of a chemically modified siNA construct (Stab 4/5, **Table IV**) targeting HBV site 1580 RNA compared to an unstabilized siRNA construct in a dose response time course HBsAg assay. The constructs were compared at different concentrations (5nM, 10 nM, 25 nM, 50 nM, and 100 nM) over the course of nine days. Activity based on HBsAg levels was determined at day 3, day 6, and day 9.

**Figure 29** shows representative data of a chemically modified siNA construct (Stab 7/8, **Table IV**) targeting HBV site 1580 RNA compared to an unstabilized siRNA construct in a dose response time course HBsAg assay. The constructs were compared at different concentrations (5nM, 10 nM, 25 nM, 50 nM, and 100 nM) over the course of nine days. SiNA activity based on HBsAg levels was determined at day 3, day 6, and day 9.

**Figure 30** shows representative data of a chemically modified siNA construct (Stab 7/11, **Table IV**) targeting HBV site 1580 RNA compared to an unstabilized siRNA construct in a dose response time course HBsAg assay. The constructs were compared at different concentrations (5nM, 10 nM, 25 nM, 50 nM, and 100 nM) over the course of nine days. SiNA activity based on HBsAg levels was determined at day 3, day 6, and day 9.

**Figure 31** shows representative data of a chemically modified siNA construct (Stab 9/10, **Table IV**) targeting HBV site 1580 RNA compared to an unstabilized siRNA construct in a dose response time course HBsAg assay. The constructs were compared at different concentrations (5nM, 10 nM, 25 nM, 50 nM, and 100 nM) over the course of nine days. SiNA activity based on HBsAg levels was determined at day 3, day 6, and day 9.

**Figure 32** shows non-limiting examples of inhibition of viral replication of a HCV/poliovirus chimera by siNA constructs targeted to HCV chimera (29579/29586; 29578/29585) compared to control (29593/29600).

5 **Figure 33** shows a non-limiting example of a dose response study demonstrating the inhibition of viral replication of a HCV/poliovirus chimera by siNA construct (29579/29586) at various concentrations (1nM, 5nM, 10nM, and 25nM) compared to control (29593/29600).

10 **Figure 34** shows a non-limiting example demonstrating the inhibition of viral replication of a HCV/poliovirus chimera by a chemically modified siRNA construct (30051/30053) compared to control construct (30052/30054).

**Figure 35** shows a non-limiting example demonstrating the inhibition of viral replication of a HCV/poliovirus chimera by a chemically modified siRNA construct (30055/30057) compared to control construct (30056/30058).

15 **Figure 36** shows a non-limiting example of several chemically modified siRNA constructs targeting viral replication of an HCV/poliovirus chimera at 10 nM treatment in comparison to a lipid control and an inverse siNA control construct 29593/ 29600.

**Figure 37** shows a non-limiting example of several chemically modified siRNA constructs targeting viral replication of a HCV/poliovirus chimera at 25 nM treatment in comparison to a lipid control and an inverse siNA control construct 29593/ 29600.

20 **Figure 38** shows a non-limiting example of several chemically modified siRNA constructs targeting viral replication of a Huh7 HCV replicon system at 25 nM treatment in comparison to untreated cells ("cells"), cells transfected with lipofectamine ("LFA2K") and inverse siNA control constructs.

25 **Figure 39** shows a non-limiting example of a dose response study using chemically modified siNA molecules (Stab 4/5, see **Table IV**) targeting HCV RNA sites 291, 300, and 303 in a Huh7 HCV replicon system at 5, 10, 25, and 100 nM treatment comparison to untreated cells ("cells"), cells transfected with lipofectamine ("LFA") and inverse siNA control constructs.

**Figure 40** shows a non-limiting example of several chemically modified siNA constructs (Stab 7/8, see **Table IV**) targeting viral replication in a Huh7 HCV replicon system at 25 nM treatment in comparison to untreated cells ("cells"), cells transfected with lipofectamine ("Lipid") and inverse siNA control constructs.

5 **Figure 41** shows a non-limiting example of a dose response study using chemically modified siNA molecules (Stab 7/8, see **Table IV**) targeting HCV site 327 in a Huh7 HCV replicon system at 5, 10, 25, 50, and 100 nM treatment in comparison to inverse siNA control constructs.

**Figure 42** shows a synthetic scheme for post-synthetic modification of a nucleic acid molecule to produce a folate conjugate.

**Figure 43** shows a synthetic scheme for generating an oligonucleotide or nucleic acid-folate conjugate.

**Figure 44** shows an alternative synthetic scheme for generating an oligonucleotide or nucleic acid-folate conjugate.

15 **Figure 45** shows an alternative synthetic scheme for post-synthetic modification of a nucleic acid molecule to produce a folate conjugate.

**Figure 46** shows a non-limiting example of a synthetic scheme for the synthesis of a N-acetyl-D-galactosamine-2'-aminouridine phosphoramidite conjugate of the invention.

**Figure 47** shows a non-limiting example of a synthetic scheme for the synthesis of a N-acetyl-D-galactosamine-D-threoninol phosphoramidite conjugate of the invention.

**Figure 48** shows a non-limiting example of a N-acetyl-D-galactosamine siNA nucleic acid conjugate of the invention. **W** shown in the example refers to a biodegradable linker, for example a nucleic acid dimer, trimer, or tetramer comprising ribonucleotides and/or deoxyribonucleotides. The siNA can be conjugated at the 3', 5' or both 3' and 5' ends of the sense strand of a double stranded siNA and/or the 3'-end of the antisense strand of the siNA. A single stranded siNA molecule can be conjugated at the 3'-end of the siNA.

**Figure 49** shows a non-limiting example of a synthetic scheme for the synthesis of a dodecanoic acid derived conjugate linker of the invention.

**Figure 50** shows a non-limiting example of a synthetic scheme for the synthesis of an oxime linked nucleic acid/peptide conjugate of the invention.

**Figure 51** shows non-limiting examples of phospholipid derived siNA conjugates of the invention. CL shown in the examples refers to a biodegradable linker, for example a  
5 nucleic acid dimer, trimer, or tetramer comprising ribonucleotides and/or deoxyribonucleotides. The siNA can be conjugated at the 3', 5' or both 3' and 5' ends of the sense strand of a double stranded siNA and/or the 3'-end of the antisense strand of the siNA. A single stranded siNA molecule can be conjugated at the 3'-end of the siNA.

**Figure 52** shows a non-limiting example of a synthetic scheme for preparing a  
10 phospholipid derived siNA conjugates of the invention.

**Figure 53** shows a non-limiting example of a synthetic scheme for preparing a poly-N-acetyl-D-galactosamine nucleic acid conjugate of the invention.

**Figure 54** shows a non-limiting example of the synthesis of siNA cholesterol conjugates of the invention using a phosphoramidite approach.

**Figure 55** shows a non-limiting example of the synthesis of siNA PEG conjugates  
15 of the invention using NHS ester coupling.

**Figure 56** shows a non-limiting example of the synthesis of siNA cholesterol conjugates of the invention using NHS ester coupling.

**Figure 57** shows a non-limiting example of various siNA cholesterol conjugates of  
20 the invention.

**Figure 58** shows a non-limiting example of various siNA cholesterol conjugates of the invention in which various linker chemistries and/or cleavable linkers can be utilized at different positions of a double stranded siNA molecule.

**Figure 59** shows a non-limiting example of various siNA cholesterol conjugates of  
25 the invention in which various linker chemistries and/or cleavable linkers can be utilized at different positions of a double stranded siNA molecule.

**Figure 60** shows a non-limiting example of various siNA cholesterol conjugates of the invention in which various linker chemistries and/or cleavable linkers can be utilized at different positions of a single stranded siNA molecule.

**Figure 61** shows a non-limiting example of various siNA phospholipid conjugates of the invention in which various linker chemistries and/or cleavable linkers can be utilized at different positions of a double stranded siNA molecule.

5 **Figure 62** shows a non-limiting example of various siNA phospholipid conjugates of the invention in which various linker chemistries and/or cleavable linkers can be utilized at different positions of a single stranded siNA molecule.

**Figure 63** shows a non-limiting example of various siNA galactosamine conjugates of the invention in which various linker chemistries and/or cleavable linkers can be utilized at different positions of a double stranded siNA molecule.

10 **Figure 64** shows a non-limiting example of various siNA galactosamine conjugates of the invention in which various linker chemistries and/or cleavable linkers can be utilized at different positions of a single stranded siNA molecule.

**Figure 65** shows a non-limiting example of various generalized siNA conjugates of the invention in which various linker chemistries and/or cleavable linkers can be utilized at  
15 different positions of a double stranded siNA molecule. CONJ in the figure refers to any biologically active compound or any other conjugate compound as described herein and in the Formulae herein.

**Figure 66** shows a non-limiting example of various generalized siNA conjugates of the invention in which various linker chemistries and/or cleavable linkers can be utilized at  
20 different positions of a single stranded siNA molecule. CONJ in the figure refers to any biologically active compound or any other conjugate compound as described herein and in the Formulae herein.

**Figure 67** shows a non-limiting example of the pharmacokinetic distribution of  
25 intact siNA in liver after administration of conjugated or unconjugated siNA molecules in mice.

**Figure 68** shows a non-limiting example of the activity of conjugated siNA constructs compared to matched chemistry unconjugated siNA constructs in a HBV cell culture system without the use of transfection lipid. As shown in the Figure, siNA conjugates provide efficacy in cell culture without the need for transfection reagent.

**Figure 69** shows a non-limiting example of a scheme for the synthesis of a mono-galactosamine phosphoramidite of the invention that can be used to generate galactosamine conjugated nucleic acid molecules.

**Figure 70** shows a non-limiting example of a scheme for the synthesis of a tri-galactosamine phosphoramidite of the invention that can be used to generate tri-galactosamine conjugated nucleic acid molecules.

**Figure 71** shows a non-limiting example of a scheme for the synthesis of another tri-galactosamine phosphoramidite of the invention that can be used to generate tri-galactosamine conjugated nucleic acid molecules.

**Figure 72** shows a non-limiting example of an alternate scheme for the synthesis of a tri-galactosamine phosphoramidite of the invention that can be used to generate tri-galactosamine conjugated nucleic acid molecules.

**Figure 73** shows a non-limiting example of a scheme for the synthesis of a cholesterol NHS ester of the invention that can be used to generate cholesterol conjugated nucleic acid molecules.

**Figure 74** shows non-limiting examples of phosphorylated siNA molecules of the invention, including linear and duplex constructs and asymmetric derivatives thereof.

**Figure 75** shows non-limiting examples of a chemically modified terminal phosphate groups of the invention.

**Figure 76** shows a non-limiting example of inhibition of VEGF induced neovascularization in the rat corneal model. VEGFr1 site 349 active siNA having "Stab 9/10" chemistry (Sirna # 31270/31273) was tested for inhibition of VEGF-induced angiogenesis at three different concentrations (2.0 ug, 1.0 ug, and 0.1  $\mu$ g dose response) as compared to a matched chemistry inverted control siNA construct (Sirna # 31276/31279) at each concentration and a VEGF control in which no siNA was administered. As shown in the figure, the active siNA construct having "Stab 9/10" chemistry (Sirna # 31270/31273) is highly effective in inhibiting VEGF-induced angiogenesis in the rat corneal model compared to the matched chemistry inverted control siNA at concentrations from 0.1  $\mu$ g to 2.0 ug.

**Figure 77** shows activity of modified siNA constructs having stab 4/5 (Sirna 30355/30366), stab 7/8 (Sirna 30612/30620), and stab 7/11 (Sirna 30612/31175)

chemistries and an all ribo siNA construct (Sirna 30287/30298) in the reduction of HBsAg levels compared to matched inverted controls at **A.** 3 days, **B.** 9 days, and **C.** 21 days post transfection. Also shown is the corresponding percent inhibition as function of time at siNA concentrations of **D.** 100 nM, **E.** 50 nM, and **F.** 25 nM.

5 **Figure 78** shows non-limiting examples of phosphorylated siNA molecules of the invention, including linear and duplex constructs and asymmetric derivatives thereof.

**Figure 79** shows non-limiting examples of chemically modified terminal phosphate groups of the invention.

10 **Figure 80** shows a non-limiting example of reduction of serum HBV DNA in mice treated with hydrodynamically administered chemically modified siNA (Stab 7/8 and Stab 9/10) targeting HBV RNA compared to matched chemistry inverted controls and a saline control.

15 **Figure 81** shows a non-limiting example of reduction of serum HBV S antigen (HBsAg) in mice treated with hydrodynamically administered chemically modified siNA (Stab 7/8 and Stab 9/10) targeting HBV RNA compared to matched chemistry inverted controls and a saline control.

20 **Figure 82** shows a non-limiting example of reduction of serum HBV RNA in mice treated with hydrodynamically administered chemically modified siNA (Stab 7/8 and Stab 9/10) targeting HBV RNA compared to matched chemistry inverted controls and a saline control.

**Figure 83** shows a non-limiting example of reduction of serum HBV DNA in mice treated with hydrodynamically administered chemically modified siNA (Stab 7/8 and Stab 9/10) targeting HBV RNA at 5 days and 7 days post administration.

25 **Figure 84** shows a non-limiting example of an assay for dose dependent reduction of Luciferase expression utilizing Stab 7/8 chemically modified siNA constructs targeting luciferase RNA sites 80, 237, and 1478 that were selected from a screen using all Stab 7/8 chemically modified siNA constructs.

**Figure 85** shows a non-limiting example of an assay for dose dependent reduction of Luciferase expression utilizing Stab 7/8 chemically modified siNA constructs targeting



luciferase RNA sites 1544 and 1607 that were selected from a screen using all Stab 7/8 chemically modified siNA constructs.

**Figure 86** shows a non-limiting example of an assay screen of Stab 7/8 siNA constructs targeting various sites of HCV RNA in a replicon system compared to untreated, lipid, and an inverted control. As shown in the figure, several Stab 7/8 constructs were identified with potent anti-HCV activity as shown by reduction in HCV RNA levels.

**Figure 87** shows a non-limiting example of an assay screen of Stab 7/8 siNA constructs targeting various sites of HBV RNA in HEpG2 cells compared to untreated cells and an inverted control. As shown in the figure, several Stab 7/8 constructs were identified with potent anti-HBV activity as shown by reduction in HBV S antigen levels.

**Figure 88** shows a non-limiting example of an assay screen of various combinations of chemically modified siNA constructs (e.g., Stab 7/8, 7/10, 7/11, 9/8, and 9/10) targeting site 1580 of HBV RNA in HEpG2 cells compared to untreated cells and an matched chemistry inverted controls. As shown in the figure, the combination chemistries tested demonstrated potent anti-HBV activity as shown by reduction in HBV S antigen levels.

**Figure 89** shows a non-limiting example of an assay screen of various combinations of chemically modified siNA constructs (e.g., Stab 7/8, 9/10, 6/10, 16/8, 16/10, 18/8, and 18/10) targeting site 1580 of HBV RNA in HEpG2 cells compared to untreated cells and an matched chemistry inverted controls. As shown in the figure, the combination chemistries tested demonstrated potent anti-HBV activity as shown by reduction in HBV S antigen levels.

**Figure 90** shows a non-limiting example of an assay screen of various combinations of chemically modified siNA constructs (e.g., Stab 4/8, 4/10, 7/5, 7/10, 9/5, 9/8, and 9/11) targeting site 1580 of HBV RNA in HEpG2 cells compared to untreated cells and an matched chemistry inverted controls. As shown in the figure, the combination chemistries tested demonstrated potent anti-HBV activity as shown by reduction in HBV S antigen levels.

**Figure 91** shows a non-limiting example of reduction of serum HBV DNA in mice treated with hydrodynamically administered

polyethylimine-polyethyleneglycol-tri-N-acetylgalactosamine (PEI-PEG-triGAL) formulated Stab 9/10 siNA targeting HBV site 1580 RNA compared to a matched chemistry inverted control.

5 **Figure 92** shows a non-limiting example of reduction of serum HBsAg in mice treated with hydrodynamically administered polyethylimine-polyethyleneglycol-tri-N-acetylgalactosamine (PEI-PEG-triGAL) formulated Stab 9/10 siNA targeting HBV site 1580 RNA compared to a matched chemistry inverted control.

10 **Figure 93** shows a non-limiting example of the general structure of a polyethylimine-polyethyleneglycol-tri-N-acetylgalactosamine (PEI-PEG-triGAL) transfection agent.

**Figure 94A** shows a non-limiting example of methodology used to design self complementary DFO constructs utilizing palidrome and/or repeat nucleic acid sequences that are identified in a target nucleic acid sequence. (i) A palindrome or repeat sequence is identified in a nucleic acid target sequence. (ii) A sequence is designed that is complementary to the target nucleic acid sequence and the palidrome sequence. (iii) An inverse repeat sequence of the non-palidrome/repeat portion of the complementary sequence is appended to the 3'-end of the complementary sequence to generate a self complimentary DFO molecule comprising sequence complementary to the nucleic acid target. (iv) The DFO molecule can self-assemble to form a double stranded oligonucleotide. **Figure 94B** shows a non-limiting representative example of a duplex forming oligonucleotide sequence. **Figure 94C** shows a non-limiting example of the self assembly schematic of a representative duplex forming oligonucleotide sequence. **Figure 94D** shows a non-limiting example of the self assembly schematic of a representative duplex forming oligonucleotide sequence followed by interaction with a target nucleic acid sequence resulting in modulation of gene expression.

25 **Figure 95** shows a non-limiting example of the design of self complementary DFO constructs utilizing palidrome and/or repeat nucleic acid sequences that are incorporated into the DFO constructs that have sequence complementary to any target nucleic acid sequence of interest. Incorporation of these palidrome/repeat sequences allow the design of DFO constructs that form duplexes in which each strand is capable of mediating

modulation of target gene expression, for example by RNAi. First, the target sequence is identified. A complementary sequence is then generated in which nucleotide or non-nucleotide modifications (shown as X or Y) are introduced into the complementary sequence that generate an artificial palindrome (shown as XYXYXY in the Figure). An inverse repeat of the non-palindrome/repeat complementary sequence is appended to the 3'-end of the complementary sequence to generate a self complementary DFO comprising sequence complementary to the nucleic acid target. The DFO can self-assemble to form a double stranded oligonucleotide.

**Figure 96** shows non-limiting examples of multifunctional siNA molecules of the invention comprising two separate polynucleotide sequences that are each capable of mediating RNAi directed cleavage of differing target nucleic acid sequences. **Figure 96A** shows a non-limiting example of a multifunctional siNA molecule having a first region that is complementary to a first target nucleic acid sequence (complementary region 1) and a second region that is complementary to a second target nucleic acid sequence (complementary region 2), wherein the first and second complementary regions are situated at the 3'-ends of each polynucleotide sequence in the multifunctional siNA. The dashed portions of each polynucleotide sequence of the multifunctional siNA construct have complementarity with regard to corresponding portions of the siNA duplex, but do not have complementarity to the target nucleic acid sequences. **Figure 96B** shows a non-limiting example of a multifunctional siNA molecule having a first region that is complementary to a first target nucleic acid sequence (complementary region 1) and a second region that is complementary to a second target nucleic acid sequence (complementary region 2), wherein the first and second complementary regions are situated at the 5'-ends of each polynucleotide sequence in the multifunctional siNA. The dashed portions of each polynucleotide sequence of the multifunctional siNA construct have complementarity with regard to corresponding portions of the siNA duplex, but do not have complementarity to the target nucleic acid sequences.

**Figure 97** shows non-limiting examples of multifunctional siNA molecules of the invention comprising a single polynucleotide sequence comprising distinct regions that are each capable of mediating RNAi directed cleavage of differing target nucleic acid sequences. **Figure 97A** shows a non-limiting example of a multifunctional siNA molecule having a first region that is complementary to a first target nucleic acid sequence

(complementary region 1) and a second region that is complementary to a second target nucleic acid sequence (complementary region 2), wherein the second complementary region is situated at the 3'-end of the polynucleotide sequence in the multifunctional siNA. The dashed portions of each polynucleotide sequence of the multifunctional siNA construct

5 have complementarity with regard to corresponding portions of the siNA duplex, but do not have complementarity to the target nucleic acid sequences. **Figure 97B** shows a non-limiting example of a multifunctional siNA molecule having a first region that is complementary to a first target nucleic acid sequence (complementary region 1) and a second region that is complementary to a second target nucleic acid sequence

10 (complementary region 2), wherein the first complementary region is situated at the 5'-end of the polynucleotide sequence in the multifunctional siNA. The dashed portions of each polynucleotide sequence of the multifunctional siNA construct have complementarity with regard to corresponding portions of the siNA duplex, but do not have complementarity to the target nucleic acid sequences. In one embodiment, these multifunctional siNA

15 constructs are processed in vivo or in vitro to generate multifunctional siNA constructs as shown in **Figure 96**.

**Figure 98** shows non-limiting examples of multifunctional siNA molecules of the invention comprising two separate polynucleotide sequences that are each capable of mediating RNAi directed cleavage of differing target nucleic acid sequences and wherein

20 the multifunctional siNA construct further comprises a self complementary, palindrome, or repeat region, thus enabling shorter bifunctional siNA constructs that can mediate RNA interference against differing target nucleic acid sequences. **Figure 98A** shows a non-limiting example of a multifunctional siNA molecule having a first region that is complementary to a first target nucleic acid sequence (complementary region 1) and a second region that is complementary to a second target nucleic acid sequence

25 (complementary region 2), wherein the first and second complementary regions are situated at the 3'-ends of each polynucleotide sequence in the multifunctional siNA, and wherein the first and second complementary regions further comprise a self complementary, palindrome, or repeat region. The dashed portions of each polynucleotide

30 sequence of the multifunctional siNA construct have complementarity with regard to corresponding portions of the siNA duplex, but do not have complementarity to the target nucleic acid sequences. **Figure 98B** shows a non-limiting example of a multifunctional

siNA molecule having a first region that is complementary to a first target nucleic acid sequence (complementary region 1) and a second region that is complementary to a second target nucleic acid sequence (complementary region 2), wherein the first and second complementary regions are situated at the 5'-ends of each polynucleotide sequence in the multifunctional siNA, and wherein the first and second complementary regions further comprise a self complementary, palindrome, or repeat region. The dashed portions of each polynucleotide sequence of the multifunctional siNA construct have complementarity with regard to corresponding portions of the siNA duplex, but do not have complementarity to the target nucleic acid sequences.

10 **Figure 99** shows non-limiting examples of multifunctional siNA molecules of the invention comprising a single polynucleotide sequence comprising distinct regions that are each capable of mediating RNAi directed cleavage of differing target nucleic acid sequences and wherein the multifunctional siNA construct further comprises a self complementary, palindrome, or repeat region, thus enabling shorter bifunctional siNA  
15 constructs that can mediate RNA interference against differing target nucleic acid sequences. **Figure 99A** shows a non-limiting example of a multifunctional siNA molecule having a first region that is complementary to a first target nucleic acid sequence (complementary region 1) and a second region that is complementary to a second target nucleic acid sequence (complementary region 2), wherein the second complementary  
20 region is situated at the 3'-end of the polynucleotide sequence in the multifunctional siNA, and wherein the first and second complementary regions further comprise a self complementary, palindrome, or repeat region. The dashed portions of each polynucleotide sequence of the multifunctional siNA construct have complementarity with regard to corresponding portions of the siNA duplex, but do not have complementarity to the target  
25 nucleic acid sequences. **Figure 99B** shows a non-limiting example of a multifunctional siNA molecule having a first region that is complementary to a first target nucleic acid sequence (complementary region 1) and a second region that is complementary to a second target nucleic acid sequence (complementary region 2), wherein the first complementary  
30 region is situated at the 5'-end of the polynucleotide sequence in the multifunctional siNA, and wherein the first and second complementary regions further comprise a self complementary, palindrome, or repeat region. The dashed portions of each polynucleotide sequence of the multifunctional siNA construct have complementarity with regard to

corresponding portions of the siNA duplex, but do not have complementarity to the target nucleic acid sequences. In one embodiment, these multifunctional siNA constructs are processed in vivo or in vitro to generate multifunctional siNA constructs as shown in **Figure 98**.

5           **Figure 100** shows a non-limiting example of how multifunctional siNA molecules of the invention can target two separate target nucleic acid molecules, such as separate RNA molecules encoding differing proteins, for example a cytokine and its corresponding receptor, differing viral strains, a virus and a cellular protein involved in viral infection or replication, or differing proteins involved in a common or divergent biologic pathway that  
10 is implicated in the maintenance of progression of disease. Each strand of the multifunctional siNA construct comprises a region having complementarity to separate target nucleic acid molecules. The multifunctional siNA molecule is designed such that each strand of the siNA can be utilized by the RISC complex to initiate RNA interference mediated cleavage of its corresponding target. These design parameters can include  
15 destabilization of each end of the siNA construct (see for example Schwarz *et al.*, 2003, *Cell*, 115, 199-208). Such destabilization can be accomplished for example by using guanosine-cytidine base pairs, alternate base pairs (e.g., wobbles), or destabilizing chemically modified nucleotides at terminal nucleotide positions as is known in the art.

**Figure 101** shows a non-limiting example of how multifunctional siNA molecules of  
20 the invention can target two separate target nucleic acid sequences within the same target nucleic acid molecule, such as alternate coding regions of a RNA, coding and non-coding regions of a RNA, or alternate splice variant regions of a RNA. Each strand of the multifunctional siNA construct comprises a region having complementarity to the separate regions of the target nucleic acid molecule. The multifunctional siNA molecule is designed  
25 such that each strand of the siNA can be utilized by the RISC complex to initiate RNA interference mediated cleavage of its corresponding target region. These design parameters can include destabilization of each end of the siNA construct (see for example Schwarz *et al.*, 2003, *Cell*, 115, 199-208). Such destabilization can be accomplished for example by using guanosine-cytidine base pairs, alternate base pairs (e.g., wobbles), or destabilizing  
30 chemically modified nucleotides at terminal nucleotide positions as is known in the art.

**Figure 102** shows a non-limiting example of the dose dependent reduction in serum HBV DNA levels following systemic intravenous administration of a Stab 7/8 siNA construct targeting HBV RNA site 263 in mice pre-treated with a HBV expressing vector via hydrodynamic injection. siNA treated groups were compared to inverted control or saline groups. A statistically significant ( $P < 0.01$ ) reduction of 0.93 log was observed in the 30mg/kg group as compared to the saline group. This result demonstrates *in vivo* activity of a systemically administered siNA.

**Figure 103** shows activity of a fully stabilized siNA construct compared to a matched chemistry inverted control, an all RNA siNA construct having identical sequence (RNA active), and a corresponding all RNA inverted control (RNA Inv), in a HBV Co-HDI mouse model. A hydrodynamic tail vein injection (HDI) containing 1 ug of the pWTD HBV vector and 0, 0.03, 0.1, 0.3 or 1.0 ug of siNA was performed on C57BL/J6 mice. Active siNA duplexes and inverted sequence controls in both native RNA and stabilized chemistry were tested. The levels of serum HBV DNA and HBsAg were measured 72 hrs post injection. **Figure 103A** shows results for HBV serum DNA levels, **Figure 103B** shows results for serum HBsAg levels, and **Figure 103C** shows results for liver HBV RNA levels in this study.

**Figure 104** shows non-limiting examples of the design of self complementary DFO constructs utilizing palidrome and/or repeat nucleic acid sequences that are incorporated into the DFO constructs that have sequence complementary to any target nucleic acid sequence of interest as described in **Figure 95**. The palidrome/repeat sequence comprises chemically modified nucleotides that are able to interact with a portion of the target nucleic acid sequence (e.g., use of modified base analogs that can form Watson Crick base pairs or non-Watson Crick base pairs such as 2-aminopurine or 2-amino-1,6-dihydropurine nucleotides or universal nucleotides).

**Figure 105** shows non-limiting examples of inhibition of VEGFR1 RNA expression using DFO molecules of the invention. Duplex DFO constructs prepared from compound numbers 32808, 32809, 32810, 32811, and 32812 were assayed along with siNA molecules having known activity against VEGFR1 RNA (compound numbers 32748/32755, 33282/32289, 31270/31273), matched chemistry inverted controls (compound numbers 32772/32779, 32296/32303, 31276/31279), and a transfection agent control (LF2K). As

shown in the Figure, the self complementary DFO sequence 32812 shows potent inhibition of VEGFR1 RNA. Sequences for compound numbers are shown in **Table I**.

**Figure 106** shows non-limiting examples of inhibition of HBV RNA expression using DFO molecules of the invention as assayed by HBsAg levels. A duplex DFO  
5 construct prepared from compound 32221 and a hairpin formed with the same sequence (32221 fold) was assayed along with a siNA construct having known activity against HBV RNA (compound number 31335/31337), a matched chemistry inverted control (compound number 31336/31338), and untreated cells (Untreated). As shown in the Figure, the self complementary DFO sequence 32221 shows significant inhibition of HBV HBsAg as a  
10 duplex. Sequences for compound numbers are shown in **Table I**.

**Figure 107** shows a non-limiting example of the results obtained from using a method to determine the probability of the occurrence of various palindromes ranging from 6 nucleotides to 14 nucleotides in an artificially generated 200K-gene sequence. The simulation revealed that 6-mer palindromes typically occur once for every given  
15 64-nucleotide sequence. An 8-mer palindrome was found to occur once for every 250-nucleotide sequence. These calculated frequencies matched well with the observed frequencies of palindrome in defined taret sequences. This allowed the estimation that approximately 78 6-mer palindromes should exist on average in any givent 5K gene.

**Figure 108** shows a non-limiting example of a study used to determine the presence  
20 of 6-mer palindromes in various genes, including Luc2, TGB-beta receptor-1, VEGF, VEGFR1, VEGFR2, HIVNL23, vaccinia, and HCV, which resulted in a large number of palindromic sites identified in each gene sequence. This algorithm considered only the Watson-Crick base pairs and excluded the presence of any mismatched and wobble base pairs. The inclusion of mismatches, wobble pairs and non-Watson-Crick base pairs can  
25 result in a large number of semi-palindromic sites suitable for the design of additional minimal duplex forming oligonucleotides.

**Figure 109** shows a non-limiting example of DFO mediated reduction of TGF-beta receptor-1 target RNA expresssion. Self complementary DFO palindrome/repeat  
30 sequences shown in **Table I** (e.g., compound # 35038, 35041, 35044, and 35045) were designed against TGF-beta receptor-1 RNA targets and were screened in cell culture experiments and irrelevant controls (Control 1, Control 2) and untreated cells along with a



transfection control (LF2K). NMuMg cells were transfected with 0.5 uL/well of lipid complexed with 25 and 100 nM DFO. Cells were incubated at 37° for 24h in the continued presence of the DFO transfection mixture. At 24h, RNA was prepared from each well of treated cells. The supernatants with the transfection mixtures were first removed and discarded, then the cells were lysed and RNA prepared from each well. Target gene expression following treatment was evaluated by RT-PCR for the TGF-beta receptor mRNA and for a control gene (36B4, an RNA polymerase subunit) for normalization. As shown in the figure, the DFO constructs displayed potent inhibition of TGF-beta receptor-1 RNA expression in this system.

10 **Figure 110** shows a non-limiting example inhibition of HBV RNA using multifunctional siNA constructs targeting HBV and PKC-alpha RNA in HepG2 cells.

**Figure 111** shows a non-limiting example inhibition of PKC-alpha RNA using multifunctional siNA constructs targeting HBV and PKC-alpha RNA in HepG2 cells.

15 **Figure 112(A-H)** shows non-limiting examples of tethered multifunctional siNA constructs of the invention. In the examples shown, a linker (e.g., nucleotide or non-nucleotide linker) connects two siNA regions (e.g., two sense, two antisense, or alternately a sense and an antisense region together. Separate sense (or sense and antisense) sequences corresponding to a first target sequence and second target sequence are hybridized to their corresponding sense and/or antisense sequences in the multifunctional siNA. In addition, various conjugates, ligands, aptamers, polymers or reporter molecules can be attached to the linker region for selective or improved delivery and/or pharmacokinetic properties.

**Figure 113** shows a non-limiting example of various dendrimer based multifunctional siNA designs.

25 **Figure 114** shows a non-limiting example of various supramolecular multifunctional siNA designs.

**Figure 115** shows a non-limiting example of a dicer enabled multifunctional siNA design using a 30 nucleotide precursor siNA construct. A 30 base pair duplex is cleaved by Dicer into 22 and 8 base pair products from either end (8 b.p. fragments not shown). For

ease of presentation the overhangs generated by dicer are not shown – but can be compensated for. Three targeting sequences are shown. The required sequence identity overlapped is indicated by grey boxes. The N's of the parent 30 b.p. siNA are suggested sites of 2'-OH positions to enable Dicer cleavage if this is tested in stabilized chemistries.

- 5 Note that processing of a 30mer duplex by Dicer RNase III does not give a precise 22+8 cleavage, but rather produces a series of closely related products (with 22+8 being the primary site). Therefore, processing by Dicer will yield a series of active siNAs.

**Figure 116** shows a non-limiting example of a dicer enabled multifunctional siNA design using a 40 nucleotide precursor siNA construct. A 40 base pair duplex is cleaved by  
10 Dicer into 20 base pair products from either end. For ease of presentation the overhangs generated by dicer are not shown – but can be compensated for. Four targeting sequences are shown in four colors, blue, light-blue and red and orange. The required sequence identity overlapped is indicated by grey boxes. This design format can be extended to larger RNAs. If chemically stabilized siNAs are bound by Dicer, then strategically located  
15 ribonucleotide linkages can enable designer cleavage products that permit our more extensive repertoire of multifunctional designs. For example cleavage products not limited to the Dicer standard of approximately 22-nucleotides can allow multifunctional siNA constructs with a target sequence identity overlap ranging from, for example, about 3 to about 15 nucleotides.

20 **Figure 117** shows a non-limiting example of inhibition of HBV RNA by dicer enabled multifunctional siNA constructs targeting HBV site 263. When the first 17 nucleotides of a siNA antisense strand (e.g., 21 nucleotide strands in a duplex with 3'-TT overhangs) are complementary to a target RNA, robust silencing was observed at 25 nM. 80% silencing was observed with only 16 nucleotide complementarity in the same format.

25 **Figure 118** shows a non-limiting example of additional multifunctional siNA construct designs of the invention. In one example, a conjugate, ligand, aptamer, label, or other moiety is attached to a region of the multifunctional siNA to enable improved delivery or pharmacokinetic profiling.

30 **Figure 119** shows a non-limiting example of additional multifunctional siNA construct designs of the invention. In one example, a conjugate, ligand, aptamer, label, or

other moiety is attached to a region of the multifunctional siNA to enable improved delivery or pharmacokinetic profiling.

**Figure 120** shows a non-limiting example of an experiment designed to determine the effect of absolute based paired sequence length of siNA constructs on RNAi efficacy. A well characterized site for siNA mediated inhibition, HBV RNA site 263 was chosen and siNA molecules ranging in length from 19 to 39 ribonucleotide base pairs in length with 3'-terminal dinucleotide TT overhangs. Transfection of the human hepatocellular carcinoma cell line, Hep G2, with replication-competent HBV DNA results in the expression of HBV proteins and the production of virions. To test the efficacy of differencing length siNAs targeted against HBV RNA, several siNA duplexes targeting site 263 within HBV pregenomic RNA were co-transfected with HBV genomic DNA once at 25 nM with lipid at 12.5 ug/ml into Hep G2 cells, and the subsequent levels of HBV RNA analyzed by RT PCR compared to cells treated with an inverted siNA control to site 263 and untreated cells. As shown in the figure, the siNA constructs from 19 to 39 base pairs were all efficacious in inhibiting HBV RNA in this system.

## DETAILED DESCRIPTION OF THE INVENTION

### Mechanism of action of Nucleic Acid Molecules of the Invention

The discussion that follows discusses the proposed mechanism of RNA interference mediated by short interfering RNA as is presently known, and is not meant to be limiting and is not an admission of prior art. Applicant demonstrates herein that chemically-modified short interfering nucleic acids possess similar or improved capacity to mediate RNAi as do siRNA molecules and are expected to possess improved stability and activity *in vivo*; therefore, this discussion is not meant to be limited to siRNA only and can be applied to siNA as a whole. By "improved capacity to mediate RNAi" or "improved RNAi activity" is meant to include RNAi activity measured *in vitro* and/or *in vivo* where the RNAi activity is a reflection of both the ability of the siNA to mediate RNAi and the stability of the siNAs of the invention. In this invention, the product of these activities can be increased *in vitro* and/or *in vivo* compared to an all RNA siRNA or a siNA containing a plurality of ribonucleotides. In some cases, the activity or stability of the siNA molecule can be decreased (i.e., less than ten-fold), but the overall activity of the siNA molecule is enhanced *in vitro* and/or *in vivo*.

RNA interference refers to the process of sequence specific post-transcriptional gene silencing in animals mediated by short interfering RNAs (siRNAs) (Zamore *et al.*, 2000, Cell, 101, 25-33; Fire *et al.*, 1998, *Nature*, 391, 806). The corresponding process in plants is commonly referred to as post-transcriptional gene silencing or RNA silencing and is also referred to as quelling in fungi. The process of post-transcriptional gene silencing is thought to be an evolutionarily-conserved cellular defense mechanism used to prevent the expression of foreign genes which is commonly shared by diverse flora and phyla (Fire *et al.*, 1999, *Trends Genet.*, 15, 358). Such protection from foreign gene expression may have evolved in response to the production of double-stranded RNAs (dsRNAs) derived from viral infection or the random integration of transposon elements into a host genome via a cellular response that specifically destroys homologous single-stranded RNA or viral genomic RNA. The presence of dsRNA in cells triggers the RNAi response through a mechanism that has yet to be fully characterized. This mechanism appears to be different from the interferon response that results from dsRNA-mediated activation of protein kinase PKR and 2', 5'-oligoadenylate synthetase resulting in non-specific cleavage of mRNA by ribonuclease L.

The presence of long dsRNAs in cells stimulates the activity of a ribonuclease III enzyme referred to as Dicer. Dicer is involved in the processing of the dsRNA into short pieces of dsRNA known as short interfering RNAs (siRNAs) (Berstein *et al.*, 2001, *Nature*, 409, 363). Short interfering RNAs derived from Dicer activity are typically about 21 to about 23 nucleotides in length and comprise about 19 base pair duplexes. Dicer has also been implicated in the excision of 21- and 22-nucleotide small temporal RNAs (stRNAs) from precursor RNA of conserved structure that are implicated in translational control (Hutvagner *et al.*, 2001, *Science*, 293, 834). The RNAi response also features an endonuclease complex containing a siRNA, commonly referred to as an RNA-induced silencing complex (RISC), which mediates cleavage of single-stranded RNA having sequence homologous to the siRNA. Cleavage of the target RNA takes place in the middle of the region complementary to the guide sequence of the siRNA duplex (Elbashir *et al.*, 2001, *Genes Dev.*, 15, 188). In addition, RNA interference can also involve small RNA (e.g., micro-RNA or miRNA) mediated gene silencing, presumably through cellular mechanisms that regulate chromatin structure and thereby prevent transcription of target gene sequences (see for example Allshire, 2002, *Science*, 297, 1818-1819; Volpe *et al.*,

2002, *Science*, 297, 1833-1837; Jenuwein, 2002, *Science*, 297, 2215-2218; and Hall *et al.*, 2002, *Science*, 297, 2232-2237). As such, siNA molecules of the invention can be used to mediate gene silencing via interaction with RNA transcripts or alternately by interaction with particular gene sequences, wherein such interaction results in gene silencing either at  
5 the transcriptional level or post-transcriptional level.

RNAi has been studied in a variety of systems. Fire *et al.*, 1998, *Nature*, 391, 806, were the first to observe RNAi in *C. elegans*. Wianny and Goetz, 1999, *Nature Cell Biol.*, 2, 70, describe RNAi mediated by dsRNA in mouse embryos. Hammond *et al.*, 2000, *Nature*, 404, 293, describe RNAi in *Drosophila* cells transfected with dsRNA. Elbashir *et al.*, 2001, *Nature*, 411, 494, describe RNAi induced by introduction of duplexes of  
10 synthetic 21-nucleotide RNAs in cultured mammalian cells including human embryonic kidney and HeLa cells. Recent work in *Drosophila* embryonic lysates has revealed certain requirements for siRNA length, structure, chemical composition, and sequence that are essential to mediate efficient RNAi activity. These studies have shown that 21 nucleotide  
15 siRNA duplexes are most active when containing two 2-nucleotide 3'-terminal nucleotide overhangs. Furthermore, substitution of one or both siRNA strands with 2'-deoxy or 2'-O-methyl nucleotides abolishes RNAi activity, whereas substitution of 3'-terminal siRNA nucleotides with deoxy nucleotides was shown to be tolerated. Mismatch sequences in the center of the siRNA duplex were also shown to abolish RNAi activity. In  
20 addition, these studies also indicate that the position of the cleavage site in the target RNA is defined by the 5'-end of the siRNA guide sequence rather than the 3'-end (Elbashir *et al.*, 2001, *EMBO J.*, 20, 6877). Other studies have indicated that a 5'-phosphate on the target-complementary strand of a siRNA duplex is required for siRNA activity and that ATP is utilized to maintain the 5'-phosphate moiety on the siRNA (Nykanen *et al.*, 2001,  
25 *Cell*, 107, 309); however, siRNA molecules lacking a 5'-phosphate are active when introduced exogenously, suggesting that 5'-phosphorylation of siRNA constructs may occur *in vivo*.

#### Duplex Forming Oligonucleotides (DFO) of the Invention

In one embodiment, the invention features siNA molecules comprising duplex  
30 forming oligonucleotides (DFO) that can self-assemble into double stranded oligonucleotides. The duplex forming oligonucleotides of the invention can be chemically

synthesized or expressed from transcription units and/or vectors. The DFO molecules of the instant invention provide useful reagents and methods for a variety of therapeutic, diagnostic, agricultural, veterinary, target validation, genomic discovery, genetic engineering and pharmacogenomic applications.

5 Applicant demonstrates herein that certain oligonucleotides, referred to herein for convenience but not limitation as duplex forming oligonucleotides or DFO molecules, are potent mediators of sequence specific regulation of gene expression. The oligonucleotides of the invention are distinct from other nucleic acid sequences known in the art (e.g.,  
10 siRNA, miRNA, stRNA, shRNA, antisense oligonucleotides etc.) in that they represent a class of linear polynucleotide sequences that are designed to self-assemble into double stranded oligonucleotides, where each strand in the double stranded oligonucleotides comprises a nucleotide sequence that is complementary to a target nucleic acid molecule. Nucleic acid molecules of the invention can thus self assemble into functional duplexes in which each strand of the duplex comprises the same polynucleotide sequence and each  
15 strand comprises a nucleotide sequence that is complementary to a target nucleic acid molecule.

Generally, double stranded oligonucleotides are formed by the assembly of two distinct oligonucleotide sequences where the oligonucleotide sequence of one strand is complementary to the oligonucleotide sequence of the second strand; such double stranded  
20 oligonucleotides are assembled from two separate oligonucleotides, or from a single molecule that folds on itself to form a double stranded structure, often referred to in the field as hairpin stem-loop structure (e.g., shRNA or short hairpin RNA). These double stranded oligonucleotides known in the art all have a common feature in that each strand of the duplex has a distinct nucleotide sequence.

25 Distinct from the double stranded nucleic acid molecules known in the art, the applicants have developed a novel, potentially cost effective and simplified method of forming a double stranded nucleic acid molecule starting from a single stranded or linear oligonucleotide. The two strands of the double stranded oligonucleotide formed according to the instant invention have the same nucleotide sequence and are not covalently linked to  
30 each other. Such double-stranded oligonucleotides molecules can be readily linked post-synthetically by methods and reagents known in the art and are within the scope of the

invention. In one embodiment, the single stranded oligonucleotide of the invention (the duplex forming oligonucleotide) that forms a double stranded oligonucleotide comprises a first region and a second region, where the second region includes a nucleotide sequence that is an inverted repeat of the nucleotide sequence in the first region, or a portion thereof, such that the single stranded oligonucleotide self assembles to form a duplex oligonucleotide in which the nucleotide sequence of one strand of the duplex is the same as the nucleotide sequence of the second strand. Non-limiting examples of such duplex forming oligonucleotides (DFOs) can optionally include certain palindrome or repeat sequences where such palindrome or repeat sequences are present in between the first region and the second region of the DFO.

In one embodiment, the invention features a duplex forming oligonucleotide (DFO) molecule, wherein the DFO comprises a duplex forming self complementary nucleic acid sequence that has nucleotide sequence complementary to a target nucleic acid sequence. The DFO molecule can comprise a single self complementary sequence or a duplex resulting from assembly of such self complementary sequences.

In one embodiment, a duplex forming oligonucleotide (DFO) of the invention comprises a first region and a second region, wherein the second region comprises a nucleotide sequence comprising an inverted repeat of nucleotide sequence of the first region such that the DFO molecule can assemble into a double stranded oligonucleotide. Such double stranded oligonucleotides can act as a short interfering nucleic acid (siNA) to modulate gene expression. Each strand of the double stranded oligonucleotide duplex formed by DFO molecules of the invention can comprise a nucleotide sequence region that is complementary to the same nucleotide sequence in a target nucleic acid molecule (e.g., target RNA).

In one embodiment, the invention features a single stranded DFO that can assemble into a double stranded oligonucleotide. The applicant has surprisingly found that a single stranded oligonucleotide with nucleotide regions of self complementarity can readily assemble into duplex oligonucleotide constructs. Such DFOs can assemble into duplexes that can inhibit gene expression in a sequence specific manner. The DFO molecules of the invention comprise a first region with nucleotide sequence that is complementary to the

nucleotide sequence of a second region and where the sequence of the first region is complementary to a target nucleic acid (e.g., RNA). The DFO can form a double stranded oligonucleotide wherein a portion of each strand of the double stranded oligonucleotide comprises a sequence complementary to a target nucleic acid sequence.

5 In one embodiment, the invention features a double stranded oligonucleotide, wherein the two strands of the double stranded oligonucleotide are not covalently linked to each other, and wherein each strand of the double stranded oligonucleotide comprises a nucleotide sequence that is complementary to the same nucleotide sequence in a target nucleic acid molecule or a portion thereof. In another embodiment, the two strands of the  
10 double stranded oligonucleotide share an identical nucleotide sequence of at least about 15, preferably at least about 16, 17, 18, 19, 20, or 21 nucleotides.

In one embodiment, a DFO molecule of the invention comprises a structure having Formula DFO-I:



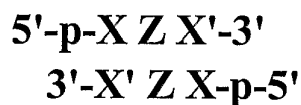
15 wherein Z comprises a palindromic or repeat nucleic acid sequence optionally with one or more modified nucleotides (e.g., nucleotide with a modified base, such as 2-amino purine, 2-amino-1,6-dihydro purine or a universal base), for example of length about 2 to about 24 nucleotides in even numbers (e.g., about 2, 4, 6, 8, 10, 12, 14, 16, 18, 20, or 22 or 24 nucleotides), X represents a nucleic acid sequence, for example of length between about 1  
20 to about 21 nucleotides (e.g., about 1, 2, 3, 4, 5, 6, 7, 8, 9, 10, 11, 12, 13, 14, 15, 16, 17, 18, 19, 20, or 21 nucleotides), X' comprises a nucleic acid sequence, for example of length about 1 and about 21 nucleotides (e.g., about 1, 2, 3, 4, 5, 6, 7, 8, 9, 10, 11, 12, 13, 14, 15, 16, 17, 18, 19, 20 or 21 nucleotides) having nucleotide sequence complementarity to sequence X or a portion thereof, p comprises a terminal phosphate group that can be present or absent,  
25 and wherein sequence X and Z, either independently or together, comprise nucleotide sequence that is complementary to a target nucleic acid sequence or a portion thereof and is of length sufficient to interact (e.g., base pair) with the target nucleic acid sequence or a portion thereof. For example, X independently can comprise a sequence from about 12 to about 21 or more (e.g., about 12, 13, 14, 15, 16, 17, 18, 19, 20, 21, or more) nucleotides in  
30 length that is complementary to nucleotide sequence in a target RNA or a portion thereof.



In another non-limiting example, the length of the nucleotide sequence of X and Z together, when X is present, that is complementary to the target RNA or a portion thereof is from about 12 to about 21 or more nucleotides (e.g., about 12, 13, 14, 15, 16, 17, 18, 19, 20, 21, or more). In yet another non-limiting example, when X is absent, the length of the nucleotide sequence of Z that is complementary to the target RNA or a portion thereof is from about 12 to about 24 or more nucleotides (e.g., about 12, 14, 16, 18, 20, 22, 24, or more). In one embodiment X, Z and X' are independently oligonucleotides, where X and/or Z comprises a nucleotide sequence of length sufficient to interact (e.g., base pair) with a nucleotide sequence in the target RNA or a portion thereof. In one embodiment, the lengths of oligonucleotides X and X' are identical. In another embodiment, the lengths of oligonucleotides X and X' are not identical. In another embodiment, the lengths of oligonucleotides X and Z, or Z and X', or X, Z and X' are either identical or different.

When a sequence is described in this specification as being of "sufficient" length to interact (*i.e.*, base pair) with another sequence, it is meant that the length is such that the number of bonds (*e.g.*, hydrogen bonds) formed between the two sequences is enough to enable the two sequence to form a duplex under the conditions of interest. Such conditions can be *in vitro* (*e.g.*, for diagnostic or assay purposes) or *in vivo* (*e.g.*, for therapeutic purposes). It is a simple and routine matter to determine such lengths.

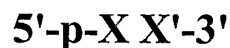
In one embodiment, the invention features a double stranded oligonucleotide construct having Formula DFO-I(a):



wherein Z comprises a palindromic or repeat nucleic acid sequence or palindromic or repeat-like nucleic acid sequence with one or more modified nucleotides (*e.g.*, nucleotides with a modified base, such as 2-amino purine, 2-amino-1,6-dihydro purine or a universal base), for example of length about 2 to about 24 nucleotides in even numbers (*e.g.*, about 2, 4, 6, 8, 10, 12, 14, 16, 18, 20, 22 or 24 nucleotides), X represents a nucleic acid sequence, for example of length about 1 to about 21 nucleotides (*e.g.*, about 1, 2, 3, 4, 5, 6, 7, 8, 9, 10, 11, 12, 13, 14, 15, 16, 17, 18, 19, 20, or 21 nucleotides), X' comprises a nucleic acid sequence, for example of length about 1 to about 21 nucleotides (*e.g.*, about 1, 2, 3, 4, 5, 6,

7, 8, 9, 10, 11, 12, 13, 14, 15, 16, 17, 18, 19, 20 or 21 nucleotides) having nucleotide sequence complementarity to sequence X or a portion thereof, p comprises a terminal phosphate group that can be present or absent, and wherein each X and Z independently comprises a nucleotide sequence that is complementary to a target nucleic acid sequence or a portion thereof and is of length sufficient to interact with the target nucleic acid sequence of a portion thereof. For example, sequence X independently can comprise a sequence from about 12 to about 21 or more nucleotides (e.g., about 12, 13, 14, 15, 16, 17, 18, 19, 20, 21, or more) in length that is complementary to a nucleotide sequence in a target RNA or a portion thereof. In another non-limiting example, the length of the nucleotide sequence of X and Z together (when X is present) that is complementary to the target RNA or a portion thereof is from about 12 to about 21 or more nucleotides (e.g., about 12, 13, 14, 15, 16, 17, 18, 19, 20, 21, or more). In yet another non-limiting example, when X is absent, the length of the nucleotide sequence of Z that is complementary to the target RNA or a portion thereof is from about 12 to about 24 or more nucleotides (e.g., about 12, 14, 16, 18, 20, 22, 24 or more). In one embodiment X, Z and X' are independently oligonucleotides, where X and/or Z comprises a nucleotide sequence of length sufficient to interact (e.g., base pair) with nucleotide sequence in the target RNA or a portion thereof. In one embodiment, the lengths of oligonucleotides X and X' are identical. In another embodiment, the lengths of oligonucleotides X and X' are not identical. In another embodiment, the lengths of oligonucleotides X and Z or Z and X' or X, Z and X' are either identical or different. In one embodiment, the double stranded oligonucleotide construct of Formula I(a) includes one or more, specifically 1, 2, 3 or 4, mismatches, to the extent such mismatches do not significantly diminish the ability of the double stranded oligonucleotide to inhibit target gene expression.

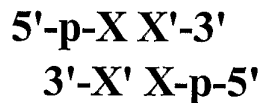
25 In one embodiment, a DFO molecule of the invention comprises structure having Formula DFO-II:



wherein each X and X' are independently oligonucleotides of length about 12 nucleotides to about 21 nucleotides, wherein X comprises, for example, a nucleic acid sequence of length about 12 to about 21 nucleotides (e.g., about 12, 13, 14, 15, 16, 17, 18, 19, 20 or 21 nucleotides), X' comprises a nucleic acid sequence, for example of length about 12 to about

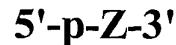
21 nucleotides (e.g., about 12, 13, 14, 15, 16, 17, 18, 19, 20, or 21 nucleotides) having nucleotide sequence complementarity to sequence X or a portion thereof, p comprises a terminal phosphate group that can be present or absent, and wherein X comprises a nucleotide sequence that is complementary to a target nucleic acid sequence (e.g., RNA) or a portion thereof and is of length sufficient to interact (e.g., base pair) with the target nucleic acid sequence of a portion thereof. In one embodiment, the length of oligonucleotides X and X' are identical. In another embodiment the length of oligonucleotides X and X' are not identical. In one embodiment, length of the oligonucleotides X and X' are sufficient to form a relatively stable double stranded oligonucleotide.

In one embodiment, the invention features a double stranded oligonucleotide construct having Formula DFO-II(a):



wherein each X and X' are independently oligonucleotides of length about 12 nucleotides to about 21 nucleotides, wherein X comprises a nucleic acid sequence, for example of length about 12 to about 21 nucleotides (e.g., about 12, 13, 14, 15, 16, 17, 18, 19, 20 or 21 nucleotides), X' comprises a nucleic acid sequence, for example of length about 12 to about 21 nucleotides (e.g., about 12, 13, 14, 15, 16, 17, 18, 19, 20 or 21 nucleotides) having nucleotide sequence complementarity to sequence X or a portion thereof, p comprises a terminal phosphate group that can be present or absent, and wherein X comprises nucleotide sequence that is complementary to a target nucleic acid sequence or a portion thereof and is of length sufficient to interact (e.g., base pair) with the target nucleic acid sequence (e.g., RNA) of a portion thereof. In one embodiment, the lengths of oligonucleotides X and X' are identical. In another embodiment, the lengths of oligonucleotides X and X' are not identical. In one embodiment, the lengths of the oligonucleotides X and X' are sufficient to form a relatively stable double stranded oligonucleotide. In one embodiment, the double stranded oligonucleotide construct of Formula II(a) includes one or more, specifically 1, 2, 3 or 4, mismatches, to the extent such mismatches do not significantly diminish the ability of the double stranded oligonucleotide to inhibit target gene expression.

In one embodiment, the invention features a DFO molecule having Formula DFO-I(b):



where Z comprises a palindromic or repeat nucleic acid sequence optionally including one  
5 or more non-standard or modified nucleotides (e.g., nucleotide with a modified base, such  
as 2-amino purine or a universal base) that can facilitate base-pairing with other nucleotides.  
Z can be, for example, of length sufficient to interact (e.g., base pair) with nucleotide  
sequence of a target nucleic acid (e.g., RNA) molecule, preferably of length of at least 12  
nucleotides, specifically about 12 to about 24 nucleotides (e.g., about 12, 14, 16, 18, 20, 22  
10 or 24 nucleotides). p represents a terminal phosphate group that can be present or absent.

In one embodiment, a DFO molecule having any of Formula DFO-I, DFO-I(a),  
DFO-I(b), DFO-II(a) or DFO-II can comprise chemical modifications as described herein  
without limitation, such as, for example, nucleotides having any of Formulae I-VII,  
stabilization chemistries as described in **Table IV**, or any other combination of modified  
15 nucleotides and non-nucleotides as described in the various embodiments herein.

In one embodiment, the palidrome or repeat sequence or modified nucleotide (e.g.,  
nucleotide with a modified base, such as 2-amino purine or a universal base) in Z of DFO  
constructs having Formula DFO-I, DFO-I(a) and DFO-I(b), comprises chemically  
modified nucleotides that are able to interact with a portion of the target nucleic acid  
20 sequence (e.g., modified base analogs that can form Watson Crick base pairs or  
non-Watson Crick base pairs).

In one embodiment, a DFO molecule of the invention, for example a DFO having  
Formula DFO-I or DFO-II, comprises about 15 to about 40 nucleotides (e.g., about 15, 16,  
17, 18, 19, 20, 21, 22, 23, 24, 25, 26, 27, 28, 29, 30, 31, 32, 33, 34, 35, 36, 37, 38, 39, or 40  
25 nucleotides). In one embodiment, a DFO molecule of the invention comprises one or more  
chemical modifications. In a non-limiting example, the introduction of chemically  
modified nucleotides and/or non-nucleotides into nucleic acid molecules of the invention  
provides a powerful tool in overcoming potential limitations of *in vivo* stability and  
bioavailability inherent to unmodified RNA molecules that are delivered exogenously. For

example, the use of chemically modified nucleic acid molecules can enable a lower dose of a particular nucleic acid molecule for a given therapeutic effect since chemically modified nucleic acid molecules tend to have a longer half-life in serum or in cells or tissues. Furthermore, certain chemical modifications can improve the bioavailability and/or potency of nucleic acid molecules by not only enhancing half-life but also facilitating the targeting of nucleic acid molecules to particular organs, cells or tissues and/or improving cellular uptake of the nucleic acid molecules. Therefore, even if the activity of a chemically modified nucleic acid molecule is reduced in vitro as compared to a native/unmodified nucleic acid molecule, for example when compared to an unmodified RNA molecule, the overall activity of the modified nucleic acid molecule can be greater than the native or unmodified nucleic acid molecule due to improved stability, potency, duration of effect, bioavailability and/or delivery of the molecule.

#### Multifunctional or Multi-targeted siNA molecules of the Invention

In one embodiment, the invention features siNA molecules comprising multifunctional short interfering nucleic acid (multifunctional siNA) molecules that modulate the expression of one or more genes in a biologic system, such as a cell, tissue, or organism. The multifunctional short interfering nucleic acid (multifunctional siNA) molecules of the invention can target more than one region of the target nucleic acid sequence or can target sequences of more than one distinct target nucleic acid molecules. The multifunctional siNA molecules of the invention can be chemically synthesized or expressed from transcription units and/or vectors. The multifunctional siNA molecules of the instant invention provide useful reagents and methods for a variety of human applications, therapeutic, diagnostic, agricultural, veterinary, target validation, genomic discovery, genetic engineering and pharmacogenomic applications.

Applicant demonstrates herein that certain oligonucleotides, referred to herein for convenience but not limitation as multifunctional short interfering nucleic acid or multifunctional siNA molecules, are potent mediators of sequence specific regulation of gene expression. The multifunctional siNA molecules of the invention are distinct from other nucleic acid sequences known in the art (e.g., siRNA, miRNA, stRNA, shRNA, antisense oligonucleotides, *etc.*) in that they represent a class of polynucleotide molecules that are designed such that each strand in the multifunctional siNA construct comprises a

nucleotide sequence that is complementary to a distinct nucleic acid sequence in one or more target nucleic acid molecules. A single multifunctional siNA molecule (generally a double-stranded molecule) of the invention can thus target more than one (e.g., 2, 3, 4, 5, or more) differing target nucleic acid target molecules. Nucleic acid molecules of the invention can also target more than one (e.g., 2, 3, 4, 5, or more) region of the same target nucleic acid sequence. As such multifunctional siNA molecules of the invention are useful in down regulating or inhibiting the expression of one or more target nucleic acid molecules. For example, a multifunctional siNA molecule of the invention can target nucleic acid molecules encoding a cytokine and its corresponding receptor(s), nucleic acid molecules encoding a virus or viral proteins and corresponding cellular proteins required for viral infection and/or replication, or differing strains of a particular virus. By reducing or inhibiting expression of more than one target nucleic acid molecule with one multifunctional siNA construct, multifunctional siNA molecules of the invention represent a class of potent therapeutic agents that can provide simultaneous inhibition of multiple targets within a disease related pathway. Such simultaneous inhibition can provide synergistic therapeutic treatment strategies without the need for separate preclinical and clinical development efforts or complex regulatory approval process.

Use of multifunctional siNA molecules that target more than one region of a target nucleic acid molecule (e.g., messenger RNA) is expected to provide potent inhibition of gene expression. For example, a single multifunctional siNA construct of the invention can target both conserved and variable regions of a target nucleic acid molecule, thereby allowing down regulation or inhibition of different splice variants encoded by a single gene, or allowing for targeting of both coding and non-coding regions of a target nucleic acid molecule.

Generally, double stranded oligonucleotides are formed by the assembly of two distinct oligonucleotides where the oligonucleotide sequence of one strand is complementary to the oligonucleotide sequence of the second strand; such double stranded oligonucleotides are generally assembled from two separate oligonucleotides (e.g., siRNA). Alternately, a duplex can be formed from a single molecule that folds on itself (e.g., shRNA or short hairpin RNA). These double stranded oligonucleotides are known in the art to mediate RNA interference and all have a common feature wherein only one nucleotide sequence region (guide sequence or the antisense sequence) has complementarity to a

target nucleic acid sequence and the other strand (sense sequence) comprises nucleotide sequence that is homologous to the target nucleic acid sequence. Generally, the antisense sequence is retained in the active RISC complex and guides the RISC to the target nucleotide sequence by means of complementary base-pairing of the antisense sequence  
5 with the target sequence for mediating sequence-specific RNA interference. It is known in the art that in some cell culture systems, certain types of unmodified siRNAs can exhibit “off target” effects. It is hypothesized that this off-target effect involves the participation of the sense sequence instead of the antisense sequence of the siRNA in the RISC complex (see for example Schwarz et al., 2003, Cell, 115, 199-208). In this instance the sense  
10 sequence is believed to direct the RISC complex to a sequence (off-target sequence) that is distinct from the intended target sequence, resulting in the inhibition of the off-target sequence. In these double stranded nucleic acid molecules, each strand is complementary to a distinct target nucleic acid sequence. However, the off-targets that are affected by these dsRNAs are not entirely predictable and are non-specific.

15 Distinct from the double stranded nucleic acid molecules known in the art, the applicants have developed a novel, potentially cost effective and simplified method of down regulating or inhibiting the expression of more than one target nucleic acid sequence using a single multifunctional siNA construct. The multifunctional siNA molecules of the invention are designed to be double-stranded or partially double stranded, such that a  
20 portion of each strand or region of the multifunctional siNA is complementary to a target nucleic acid sequence of choice. As such, the multifunctional siNA molecules of the invention are not limited to targeting sequences that are complementary to each other, but rather to any two differing target nucleic acid sequences. Multifunctional siNA molecules of the invention are designed such that each strand or region of the multifunctional siNA  
25 molecule, that is complementary to a given target nucleic acid sequence, is of suitable length (*e.g.*, from about 16 to about 28 nucleotides in length, preferably from about 18 to about 28 nucleotides in length) for mediating RNA interference against the target nucleic acid sequence. The complementarity between the target nucleic acid sequence and a strand or region of the multifunctional siNA must be sufficient (at least about 8 base pairs) for  
30 cleavage of the target nucleic acid sequence by RNA interference. multifunctional siNA of the invention is expected to minimize off-target effects seen with certain siRNA sequences, such as those described in (Schwarz *et al.*, supra).

It has been reported that dsRNAs of length between 29 base pairs and 36 base pairs (Tuschl *et al.*, International PCT Publication No. WO 02/44321) do not mediate RNAi. One reason these dsRNAs are inactive may be the lack of turnover or dissociation of the strand that interacts with the target RNA sequence, such that the RISC complex is not able to efficiently interact with multiple copies of the target RNA resulting in a significant decrease in the potency and efficiency of the RNAi process. Applicant has surprisingly found that the multifunctional siNAs of the invention can overcome this hurdle and are capable of enhancing the efficiency and potency of RNAi process. As such, in certain embodiments of the invention, multifunctional siNAs of length between about 29 to about 36 base pairs can be designed such that, a portion of each strand of the multifunctional siNA molecule comprises a nucleotide sequence region that is complementary to a target nucleic acid of length sufficient to mediate RNAi efficiently (e.g., about 15 to about 23 base pairs) and a nucleotide sequence region that is not complementary to the target nucleic acid. By having both complementary and non-complementary portions in each strand of the multifunctional siNA, the multifunctional siNA can mediate RNA interference against a target nucleic acid sequence without being prohibitive to turnover or dissociation (e.g., where the length of each strand is too long to mediate RNAi against the respective target nucleic acid sequence). Furthermore, design of multifunctional siNA molecules of the invention with internal overlapping regions allows the multifunctional siNA molecules to be of favorable (decreased) size for mediating RNA interference and of size that is well suited for use as a therapeutic agent (e.g., wherein each strand is independently from about 18 to about 28 nucleotides in length). Non-limiting examples are illustrated in the enclosed **Figures 96-101 and 112**.

In one embodiment, a multifunctional siNA molecule of the invention comprises a first region and a second region, where the first region of the multifunctional siNA comprises a nucleotide sequence complementary to a nucleic acid sequence of a first target nucleic acid molecule, and the second region of the multifunctional siNA comprises nucleic acid sequence complementary to a nucleic acid sequence of a second target nucleic acid molecule. In one embodiment, a multifunctional siNA molecule of the invention comprises a first region and a second region, where the first region of the multifunctional siNA comprises nucleotide sequence complementary to a nucleic acid sequence of the first region of a target nucleic acid molecule, and the second region of the multifunctional siNA



comprises nucleotide sequence complementary to a nucleic acid sequence of a second region of a the target nucleic acid molecule. In another embodiment, the first region and second region of the multifunctional siNA can comprise separate nucleic acid sequences that share some degree of complementarity (e.g., from about 1 to about 10 complementary nucleotides). In certain embodiments, multifunctional siNA constructs comprising separate nucleic acid sequences can be readily linked post-synthetically by methods and reagents known in the art and such linked constructs are within the scope of the invention. Alternately, the first region and second region of the multifunctional siNA can comprise a single nucleic acid sequence having some degree of self complementarity, such as in a hairpin or stem-loop structure. Non-limiting examples of such double stranded and hairpin multifunctional short interfering nucleic acids are illustrated in **Figures 96 and 97** respectively. These multifunctional short interfering nucleic acids (multifunctional siNAs) can optionally include certain overlapping nucleotide sequence where such overlapping nucleotide sequence is present in between the first region and the second region of the multifunctional siNA (see for example **Figures 98 and 99**).

In one embodiment, the invention features a multifunctional short interfering nucleic acid (multifunctional siNA) molecule, wherein each strand of the the multifunctional siNA independently comprises a first region of nucleic acid sequence that is complementary to a distinct target nucleic acid sequence and the second region of nucleotide sequence that is not complementary to the target sequence. The target nucleic acid sequence of each strand is in the same target nucleic acid molecule or different target nucleic acid molecules.

In another embodiment, the multifunctional siNA comprises two strands, where: (a) the first strand comprises a region having sequence complementarity to a target nucleic acid sequence (complementary region 1) and a region having no sequence complementarity to the target nucleotide sequence (non-complementary region 1); (b) the second strand of the multifunction siNA comprises a region having sequence complementarity to a target nucleic acid sequence that is distinct from the target nucleotide sequence complementary to the first strand nucleotide sequence (complementary region 2), and a region having no sequence complementarity to the target nucleotide sequence of complementary region 2 (non-complementary region 2); (c) the complementary region 1 of the first strand comprises a nucleotide sequence that is complementary to a nucleotide sequence in the non-complementary region 2 of the second strand and the complementary region 2 of the

second strand comprises a nucleotide sequence that is complementary to a nucleotide sequence in the non-complementary region 1 of the first strand. The target nucleic acid sequence of complementary region 1 and complementary region 2 is in the same target nucleic acid molecule or different target nucleic acid molecules.

5 In another embodiment, the multifunctional siNA comprises two strands, where: (a) the first strand comprises a region having sequence complementarity to a target nucleic acid sequence derived from a gene (e.g., mammalian gene, viral gene or genome, bacterial gene or a plant gene) (complementary region 1) and a region having no sequence complementarity to the target nucleotide sequence of complementary region 1  
10 (non-complementary region 1); (b) the second strand of the multifunction siNA comprises a region having sequence complementarity to a target nucleic acid sequence derived from a gene that is distinct from the gene of complementary region 1 (complementary region 2), and a region having no sequence complementarity to the target nucleotide sequence of complementary region 2 (non-complementary region 2); (c) the complementary region 1 of  
15 the first strand comprises a nucleotide sequence that is complementary to a nucleotide sequence in the non-complementary region 2 of the second strand and the complementary region 2 of the second strand comprises a nucleotide sequence that is complementary to a nucleotide sequence in the non-complementary region 1 of the first strand.

In another embodiment, the multifunctional siNA comprises two strands, where: (a)  
20 the first strand comprises a region having sequence complementarity to a target nucleic acid sequence derived from a gene (e.g., mammalian gene, viral gene or genome, bacterial gene or a plant gene) (complementary region 1) and a region having no sequence complementarity to the target nucleotide sequence of complementary region 1 (non-complementary region 1); (b) the second strand of the multifunction siNA comprises  
25 a region having sequence complementarity to a target nucleic acid sequence distinct from the target nucleic acid sequence of complementary region 1 (complementary region 2), provided, however, that the target nucleic acid sequence for complementary region 1 and target nucleic acid sequence for complementary region 2 are both derived from the same gene, and a region having no sequence complementarity to the target nucleotide sequence  
30 of complementary region 2 (non-complementary region 2); (c) the complementary region 1 of the first strand comprises a nucleotide sequence that is complementary to a nucleotide sequence in the non-complementary region 2 of the second strand and the complementary

region 2 of the second strand comprises a nucleotide sequence that is complementary to nucleotide sequence in the non-complementary region 1 of the first strand.

In one embodiment, the invention features a multifunctional short interfering nucleic acid (multifunctional siNA) molecule, wherein the multifunctional siNA comprises two  
5 complementary nucleic acid sequences in which the first sequence comprises a first region having nucleotide sequence complementary to nucleotide sequence within a target nucleic acid molecule, and in which the second sequence comprises a first region having nucleotide sequence complementary to a distinct nucleotide sequence within the same target nucleic acid molecule. Preferably, the first region of the first sequence is also complementary to the  
10 nucleotide sequence of the second region of the second sequence, and where the first region of the second sequence is complementary to the nucleotide sequence of the second region of the first sequence,

In one embodiment, the invention features a multifunctional short interfering nucleic acid (multifunctional siNA) molecule, wherein the multifunctional siNA comprises two  
15 complementary nucleic acid sequences in which the first sequence comprises a first region having a nucleotide sequence complementary to a nucleotide sequence within a first target nucleic acid molecule, and in which the second sequence comprises a first region having a nucleotide sequence complementary to a distinct nucleotide sequence within a second target nucleic acid molecule. Preferably, the first region of the first sequence is also  
20 complementary to the nucleotide sequence of the second region of the second sequence, and where the first region of the second sequence is complementary to the nucleotide sequence of the second region of the first sequence,

In one embodiment, the invention features a multifunctional siNA molecule comprising a first region and a second region, where the first region comprises a nucleic  
25 acid sequence having between about 18 to about 28 nucleotides complementary to a nucleic acid sequence within a first target nucleic acid molecule, and the second region comprises nucleotide sequence having between about 18 to about 28 nucleotides complementary to a distinct nucleic acid sequence within a second target nucleic acid molecule.

In one embodiment, the invention features a multifunctional siNA molecule  
30 comprising a first region and a second region, where the first region comprises nucleic acid sequence having between about 18 to about 28 nucleotides complementary to a nucleic acid

sequence within a target nucleic acid molecule, and the second region comprises nucleotide sequence having between about 18 to about 28 nucleotides complementary to a distinct nucleic acid sequence within the same target nucleic acid molecule.

5 In one embodiment, the invention features a double stranded multifunctional short interfering nucleic acid (multifunctional siNA) molecule, wherein one strand of the multifunctional siNA comprises a first region having nucleotide sequence complementary to a first target nucleic acid sequence, and the second strand comprises a first region having a nucleotide sequence complementary to a second target nucleic acid sequence. The first and second target nucleic acid sequences can be present in separate target nucleic acid  
10 molecules or can be different regions within the same target nucleic acid molecule. As such, multifunctional siNA molecules of the invention can be used to target the expression of different genes, splice variants of the same gene, both mutant and conserved regions of one or more gene transcripts, or both coding and non-coding sequences of the same or differing genes or gene transcripts.

15 In one embodiment, a target nucleic acid molecule of the invention encodes a single protein. In another embodiment, a target nucleic acid molecule encodes more than one protein (e.g., 1, 2, 3, 4, 5 or more proteins). As such, a multifunctional siNA construct of the invention can be used to down regulate or inhibit the expression of several proteins. For example, a multifunctional siNA molecule comprising a region in one strand having  
20 nucleotide sequence complementarity to a first target nucleic acid sequence derived from a gene encoding one protein (e.g., a cytokine, such as vascular endothelial growth factor or VEGF) and the second strand comprising a region with nucleotide sequence complementarity to a second target nucleic acid sequence present in target nucleic acid molecules derived from genes encoding two proteins (e.g., two differing receptors, such as  
25 VEGF receptor 1 and VEGF receptor 2, for a single cytokine, such as VEGF) can be used to down regulate, inhibit, or shut down a particular biologic pathway by targeting, for example, a cytokine and receptors for the cytokine, or a ligand and receptors for the ligand.

In one embodiment the invention takes advantage of conserved nucleotide sequences present in different isoforms of cytokines or ligands and receptors for the cytokines or  
30 ligands. By designing multifunctional siNAs in a manner where one strand includes a sequence that is complementary to a target nucleic acid sequence conserved among various

isoforms of a cytokine and the other strand includes sequence that is complementary to a target nucleic acid sequence conserved among the receptors for the cytokine, it is possible to selectively and effectively modulate or inhibit a biological pathway or multiple genes in a biological pathway using a single multifunctional siNA.

5           In another nonlimiting example, a multifunctional siNA molecule comprising a region in one strand having a nucleotide sequence complementarity to a first target nucleic acid sequence present in target nucleic acid molecules encoding two proteins (e.g., two isoforms of a cytokine such as VEGF, including for example any of VEGF-A, VEGF-B, VEGF-C, and/or VEGF-D) and the second strand comprising a region with a nucleotide  
10          sequence complementarity to a second target nucleic acid sequence present in target nucleotide molecules encoding two additional proteins (e.g., two differing receptors for the cytokine, such as VEGFR1, VEGFR2, and/or VEGFR3) can be used to down regulate, inhibit, or shut down a particular biologic pathway by targeting different isoforms of a cytokine and receptors for such cytokines.

15           In another non-limiting example, a multifunctional siNA molecule comprising a region in one strand having a nucleotide sequence complementarity to a first target nucleic acid sequence derived from a target nucleic acid molecule encoding a virus or a viral protein (e.g., HIV) and the second strand comprising a region having a nucleotide sequence complementarity to a second target nucleic acid sequence present in target nucleic acid  
20          molecule encoding a cellular protein (e.g., a receptor for the virus, such as CCR5 receptor for HIV) can be used to down regulate, inhibit, or shut down the viral replication and infection by targeting the virus and cellular proteins necessary for viral infection or replication.

          In another nonlimiting example, a multifunctional siNA molecule comprising a  
25          region in one strand having a nucleotide sequence complementarity to a first target nucleic acid sequence (e.g., conserved sequence) present in a target nucleic acid molecule such as a viral genome (e.g., HIV genomic RNA) and the second strand comprising a region having a nucleotide sequence complementarity to a second target nucleic acid sequence (e.g., conserved sequence) present in target nucleic acid molecule derived from a gene encoding  
30          a viral protein (e.g., HIV proteins, such as TAT, REV, ENV or NEF) to down regulate,

inhibit, or shut down the viral replication and infection by targeting the viral genome and viral encoded proteins necessary for viral infection or replication.

In one embodiment the invention takes advantage of conserved nucleotide sequences present in different strains, isotypes or forms of a virus and genes encoded by these  
5 different strains, isotypes and forms of the virus. By designing multifunctional siNAs in a manner where one strand includes a sequence that is complementary to target nucleic acid sequence conserved among various strains, isotypes or forms of a virus and the other strand includes sequence that is complementary to target nucleic acid sequence conserved in a protein encoded by the virus, it is possible to selectively and effectively inhibit viral  
10 replication or infection using a single multifunctional siNA.

In one embodiment, a multifunctional short interfering nucleic acid (multifunctional siNA) of the invention comprises a region in each strand, wherein the region in one strand comprises nucleotide sequence complementary to a cytokine and the region in the second strand comprises nucleotide sequence complementary to a corresponding receptor for the  
15 cytokine. Non-limiting examples of cytokines include vascular endothelial growth factors (e.g., VEGF-A, VEGF-B, VEGF-C, VEGF-D), interleukins (e.g., IL-1alpha, IL-1beta, IL-2, IL-3, IL-4, IL-5, IL-6, IL-7, IL-8, IL-9, IL-10, IL-11, IL-12, IL-13), tumor necrosis factors (e.g., TNF-alpha, TNF-beta), colony stimulating factors (e.g., CSFs), interferons (e.g., IFN-gamma), nerve growth factors (e.g., NGFs), epidermal growth factors (e.g.,  
20 EGF), platelet derived growth factors (e.g., PDGF), fibroblast growth factors (e.g., FGF), transforming growth factors (e.g., TGF-alpha and TGF-beta), erythropoietins (e.g., Epo), and Insulin like growth factors (e.g., IGF-1, IGF-2) and non-limiting examples of cytokine receptors include receptors for each of the above cytokines.

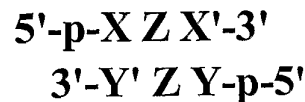
In one embodiment, a multifunctional short interfering nucleic acid (multifunctional  
25 siNA) of the invention comprises a first region and a second region, wherein the first region comprises nucleotide sequence complementary to a viral RNA of a first viral strain and the second region comprises nucleotide sequence complementary to a viral RNA of a second viral strain. In one embodiment, the first and second regions can comprise nucleotide sequence complementary to shared or conserved RNA sequences of differing viral strains  
30 or classes or viral strains. Non-limiting examples of viruses include Hepatitis C Virus (HCV), Hepatitis B Virus (HBV), Human Immunodeficiency Virus type 1 (HIV-1),

Human Immunodeficiency Virus type 2 (HIV-2), West Nile Virus (WNV), cytomegalovirus (CMV), respiratory syncytial virus (RSV), influenza virus, rhinovirus, papillomavirus (HPV), Herpes Simplex Virus (HSV), severe acute respiratory virus (SARS), and other viruses such as HTLV.

- 5           In one embodiment, a multifunctional short interfering nucleic acid (multifunctional siNA) of the invention comprises a first region and a second region, wherein the first region comprises a nucleotide sequence complementary to a viral RNA encoding one or more viruses (e.g., one or more strains of virus) and the second region comprises a nucleotide sequence complementary to a viral RNA encoding one or more interferon agonist proteins.
- 10          In one embodiment, the first region can comprise a nucleotide sequence complementary to shared or conserved RNA sequences of differing viral strains or classes or viral strains. Non-limiting examples of viruses include Hepatitis C Virus (HCV), Hepatitis B Virus (HBV), Human Immunodeficiency Virus type 1 (HIV-1), Human Immunodeficiency Virus type 2 (HIV-2), West Nile Virus (WNV), cytomegalovirus (CMV), respiratory syncytial virus (RSV), influenza virus, rhinovirus, papillomavirus (HPV), Herpes Simplex Virus (HSV), severe acute respiratory virus (SARS), and other viruses such as HTLV. Non-limiting example of interferon agonist proteins include any protein that is capable of inhibition or suppressing RNA silencing (e.g., RNA binding proteins such as E3L or NS1 or equivalents thereof, see for example Li *et al.*, 2004, *PNAS*, 101, 1350-1355)
- 15
- 20           In one embodiment, a multifunctional short interfering nucleic acid (multifunctional siNA) of the invention comprises a first region and a second region, wherein the first region comprises nucleotide sequence complementary to a viral RNA and the second region comprises nucleotide sequence complementary to a cellular RNA that is involved in viral infection and/or replication. Non-limiting examples of viruses include Hepatitis C Virus
- 25          (HCV), Hepatitis B Virus (HBV), Human Immunodeficiency Virus type 1 (HIV-1), Human Immunodeficiency Virus type 2 (HIV-2), West Nile Virus (WNV), cytomegalovirus (CMV), respiratory syncytial virus (RSV), influenza virus, rhinovirus, papillomavirus (HPV), Herpes Simplex Virus (HSV), severe acute respiratory virus (SARS), and other viruses such as HTLV. Non-limiting examples of cellular RNAs
- 30          involved in viral infection and/or replication include cellular receptors, cell surface molecules, cellular enzymes, cellular transcription factors, and/or cytokines, second messengers, and cellular accessory molecules including, but not limited to, interferon

agonsit proteins (e.g., E3L or NS1 or equivalents thereof, see for example Li *et al.*, 2004, *PNAS*, 101, 1350-1355), interferon regulatory factors (IRFs); cellular PKR protein kinase (PKR); human eukaryotic initiation factors 2B (eIF2B gamma and/or eIF2gamma); human DEAD Box protein (DDX3); and cellular proteins that bind to the poly(U) tract of the HCV  
 5 3'-UTR, such as polypyrimidine tract-binding protein, CD4 receptors, CXCR4 (Fusin; LESTR; NPY3R); CCR5 (CKR-5, CMKRB5); CCR3 (CC-CKR-3, CKR-3, CMKBR3); CCR2 (CCR2b, CMKBR2); CCR1 (CKR1, CMKBR1); CCR4 (CKR-4); CCR8 (ChemR1, TER1, CMKBR8); CCR9 (D6); CXCR2 (IL-8RB); STRL33 (Bonzo; TYMSTR); US28; V28 (CMKBRL1, CX3CR1, GPR13); GPR1; GPR15 (BOB); Apj (AGTRL1); ChemR23  
 10 receptors, Heparan Sulfate Proteoglycans, HSPG2; SDC2; SDC4; GPC1; SDC3; SDC1; Galactoceramides; Erythrocyte-expressed Glycolipids; N-myristoyltransferase (NMT, NMT2); Glycosylation Enzymes; gp-160 Processing Enzymes (PCSK5); Ribonucleotide Reductase; Polyamine Biosynthesis enzymes; SP-1; NF-kappa B (NFKB2, RELA, and NFKB1); Tumor Necrosis Factor-alpha (TNF-alpha); Interleukin 1 alpha (IL-1 alpha);  
 15 Interleukin 6 (IL-6); Phospholipase C (PLC); Protein Kinase C (PKC), Cyclophilins, (PPID, PPIA, PPIE, PPIB, PPIF, PPIG, and PPIC); Mitogen Activated Protein Kinase (MAP-Kinase, MAPK1); and Extracellular Signal-Regulated Kinase (ERK-Kinase), (see for example Schang, 2002, *Journal of Antimicrobial Chemotherapy*, 50, 779-792 and Ludwig *et al.*, 2003, *Trends. Mol. Med.*, 9, 46-52).

20 In one embodiment, a double stranded multifunctional siNA molecule of the invention comprises a structure having Formula MF-I:

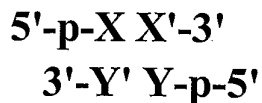


wherein each 5'-p-XZX'-3' and 5'-p-YZY'-3' are independently an oligonucleotide of  
 25 length between about 20 nucleotides and about 300 nucleotides, preferably between about 20 and about 200 nucleotides, about 20 and about 100 nucleotides, about 20 and about 40 nucleotides, about 20 and about 40 nucleotides, about 24 and about 38 nucleotides, or about 26 and about 38 nucleotides; XZ comprises a nucleic acid sequence that is complementary to a first target nucleic acid sequence; YZ is an oligonucleotide comprising nucleic acid  
 30 sequence that is complementary to a second target nucleic acid sequence; Z comprises nucleotide sequence of length about 1 to about 24 nucleotides (e.g., about 1, 2, 3, 4, 5, 6, 7,



8, 9, 10, 11, 12, 13, 14, 15, 16, 17, 18, 19, 20, 21, 22, 23, or 24 nucleotides) that is self complimentary; X comprises nucleotide sequence of length about 1 to about 100 nucleotides, preferably about 1 to about 21 nucleotides (e.g., about 1, 2, 3, 4, 5, 6, 7, 8, 9, 10, 11, 12, 13, 14, 15, 16, 17, 18, 19, 20, or 21 nucleotides) that is complementary to nucleotide sequence present in region Y'; Y comprises nucleotide sequence of length about 1 to about 100 nucleotides, preferably about 1- about 21 nucleotides (e.g., about 1, 2, 3, 4, 5, 6, 7, 8, 9, 10, 11, 12, 13, 14, 15, 16, 17, 18, 19, 20 or 21 nucleotides) that is complementary to nucleotide sequence present in region X'; each p comprises a terminal phosphate group that is independently present or absent; each XZ and YZ is independently of length sufficient to stably interact (i.e., base pair) with the first and second target nucleic acid sequence, respectively, or a portion thereof. For example, each sequence X and Y can independently comprise sequence from about 12 to about 21 or more nucleotides in length (e.g., about 12, 13, 14, 15, 16, 17, 18, 19, 20, 21, or more) that is complementary to a target nucleotide sequence in different target nucleic acid molecules, such as target RNAs or a portion thereof. In another non-limiting example, the length of the nucleotide sequence of X and Z together that is complementary to the first target nucleic acid sequence (e.g., RNA) or a portion thereof is from about 12 to about 21 or more nucleotides (e.g., about 12, 13, 14, 15, 16, 17, 18, 19, 20, 21, or more). In another non-limiting example, the length of the nucleotide sequence of Y and Z together, that is complementary to the second target nucleic acid sequence (e.g., RNA) or a portion thereof is from about 12 to about 21 or more nucleotides (e.g., about 12, 13, 14, 15, 16, 17, 18, 19, 20, 21, or more). In one embodiment, the first target nucleic acid sequence and the second target nucleic acid sequence are present in the same target nucleic acid molecule. In another embodiment, the first target nucleic acid sequence and the second target nucleic acid sequence are present in different target nucleic acid molecules. In one embodiment, Z comprises a palindrome or a repeat sequence. In one embodiment, the lengths of oligonucleotides X and X' are identical. In another embodiment, the lengths of oligonucleotides X and X' are not identical. In one embodiment, the lengths of oligonucleotides Y and Y' are identical. In another embodiment, the lengths of oligonucleotides Y and Y' are not identical. In one embodiment, the double stranded oligonucleotide construct of Formula I(a) includes one or more, specifically 1, 2, 3 or 4, mismatches, to the extent such mismatches do not significantly diminish the ability of the double stranded oligonucleotide to inhibit target gene expression.

In one embodiment, a multifunctional siNA molecule of the invention comprises a structure having Formula MF-II:



wherein each 5'-p-XX'-3' and 5'-p-YY'-3' are independently an oligonucleotide of length  
5 between about 20 nucleotides and about 300 nucleotides, preferably between about 20 and  
about 200 nucleotides, about 20 and about 100 nucleotides, about 20 and about 40  
nucleotides, about 20 and about 40 nucleotides, about 24 and about 38 nucleotides, or about  
26 and about 38 nucleotides; X comprises a nucleic acid sequence that is complementary to  
a first target nucleic acid sequence; Y is an oligonucleotide comprising nucleic acid  
10 sequence that is complementary to a second target nucleic acid sequence; X comprises a  
nucleotide sequence of length about 1 to about 100 nucleotides, preferably about 1 to about  
21 nucleotides (e.g., about 1, 2, 3, 4, 5, 6, 7, 8, 9, 10, 11, 12, 13, 14, 15, 16, 17, 18, 19, 20, or  
21 nucleotides) that is complementary to nucleotide sequence present in region Y'; Y  
comprises nucleotide sequence of length about 1 to about 100 nucleotides, preferably  
15 about 1 to about 21 nucleotides (e.g., about 1, 2, 3, 4, 5, 6, 7, 8, 9, 10, 11, 12, 13, 14, 15, 16,  
17, 18, 19, 20 or 21 nucleotides) that is complementary to nucleotide sequence present in  
region X'; each p comprises a terminal phosphate group that is independently present or  
absent; each X and Y independently is of length sufficient to stably interact (i.e., base pair)  
with the first and second target nucleic acid sequence, respectively, or a portion thereof.  
20 For example, each sequence X and Y can independently comprise sequence from about 12  
to about 21 or more nucleotides in length (e.g., about 12, 13, 14, 15, 16, 17, 18, 19, 20, 21,  
or more) that is complementary to a target nucleotide sequence in different target nucleic  
acid molecules, such as target RNAs or a portion thereof. In one embodiment, the first  
target nucleic acid sequence and the second target nucleic acid sequence are present in the  
25 same target nucleic acid molecule. In another embodiment, the first target nucleic acid  
sequence and the second target nucleic acid sequence are present in different target nucleic  
acid molecules. In one embodiment, Z comprises a palindrome or a repeat sequence. In one  
embodiment, the lengths of oligonucleotides X and X' are identical. In another  
embodiment, the lengths of oligonucleotides X and X' are not identical. In one  
30 embodiment, the lengths of oligonucleotides Y and Y' are identical. In another  
embodiment, the lengths of oligonucleotides Y and Y' are not identical. In one

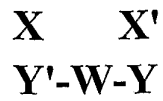
embodiment, the double stranded oligonucleotide construct of Formula I(a) includes one or more, specifically 1, 2, 3 or 4, mismatches, to the extent such mismatches do not significantly diminish the ability of the double stranded oligonucleotide to inhibit target gene expression.

- 5           In one embodiment, a multifunctional siNA molecule of the invention comprises a structure having Formula MF-III:



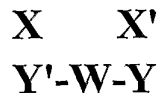
wherein each X, X', Y, and Y' is independently an oligonucleotide of length between about 15 nucleotides and about 50 nucleotides, preferably between about 18 and about 40  
 10 nucleotides, or about 19 and about 23 nucleotides; X comprises nucleotide sequence that is complementary to nucleotide sequence present in region Y'; X' comprises nucleotide sequence that is complementary to nucleotide sequence present in region Y; each X and X' is independently of length sufficient to stably interact (i.e., base pair) with a first and a second target nucleic acid sequence, respectively, or a portion thereof; W represents a  
 15 nucleotide or non-nucleotide linker that connects sequences Y' and Y; and the multifunctional siNA directs cleavage of the first and second target sequence via RNA interference. In one embodiment, region W connects the 3'-end of sequence Y' with the 3'-end of sequence Y. In one embodiment, region W connects the 3'-end of sequence Y' with the 5'-end of sequence Y. In one embodiment, region W connects the 5'-end of  
 20 sequence Y' with the 5'-end of sequence Y. In one embodiment, region W connects the 5'-end of sequence Y' with the 3'-end of sequence Y. In one embodiment, a terminal phosphate group is present at the 5'-end of sequence X. In one embodiment, a terminal phosphate group is present at the 5'-end of sequence X'. In one embodiment, a terminal phosphate group is present at the 5'-end of sequence Y. In one embodiment, a terminal  
 25 phosphate group is present at the 5'-end of sequence Y'. In one embodiment, W connects sequences Y and Y' via a biodegradable linker. In one embodiment, W further comprises a conjugate, lable, aptamer, ligand, lipid, or polymer.

In one embodiment, a multifunctional siNA molecule of the invention comprises a structure having Formula MF-IV:



wherein each X, X', Y, and Y' is independently an oligonucleotide of length between about 15 nucleotides and about 50 nucleotides, preferably between about 18 and about 40 nucleotides, or about 19 and about 23 nucleotides; X comprises nucleotide sequence that is complementary to nucleotide sequence present in region Y'; X' comprises nucleotide sequence that is complementary to nucleotide sequence present in region Y; each Y and Y' is independently of length sufficient to stably interact (i.e., base pair) with a first and a second target nucleic acid sequence, respectively, or a portion thereof; W represents a nucleotide or non-nucleotide linker that connects sequences Y' and Y; and the multifunctional siNA directs cleavage of the first and second target sequence via RNA interference. In one embodiment, region W connects the 3'-end of sequence Y' with the 3'-end of sequence Y. In one embodiment, region W connects the 3'-end of sequence Y' with the 5'-end of sequence Y. In one embodiment, region W connects the 5'-end of sequence Y' with the 5'-end of sequence Y. In one embodiment, region W connects the 5'-end of sequence Y' with the 3'-end of sequence Y. In one embodiment, a terminal phosphate group is present at the 5'-end of sequence X. In one embodiment, a terminal phosphate group is present at the 5'-end of sequence X'. In one embodiment, a terminal phosphate group is present at the 5'-end of sequence Y. In one embodiment, a terminal phosphate group is present at the 5'-end of sequence Y'. In one embodiment, W connects sequences Y and Y' via a biodegradable linker. In one embodiment, W further comprises a conjugate, lable, aptamer, ligand, lipid, or polymer.

In one embodiment, a multifunctional siNA molecule of the invention comprises a structure having Formula MF-V:



wherein each X, X', Y, and Y' is independently an oligonucleotide of length between about 15 nucleotides and about 50 nucleotides, preferably between about 18 and about 40 nucleotides, or about 19 and about 23 nucleotides; X comprises nucleotide sequence that is complementary to nucleotide sequence present in region Y'; X' comprises nucleotide sequence that is complementary to nucleotide sequence present in region Y; each X, X', Y,

or Y' is independently of length sufficient to stably interact (i.e., base pair) with a first, second, third, or fourth target nucleic acid sequence, respectively, or a portion thereof; W represents a nucleotide or non-nucleotide linker that connects sequences Y' and Y; and the multifunctional siNA directs cleavage of the first, second, third, and/or fourth target sequence via RNA interference. In one embodiment, region W connects the 3'-end of sequence Y' with the 3'-end of sequence Y. In one embodiment, region W connects the 3'-end of sequence Y' with the 5'-end of sequence Y. In one embodiment, region W connects the 5'-end of sequence Y' with the 5'-end of sequence Y. In one embodiment, region W connects the 5'-end of sequence Y' with the 3'-end of sequence Y. In one embodiment, a terminal phosphate group is present at the 5'-end of sequence X. In one embodiment, a terminal phosphate group is present at the 5'-end of sequence X'. In one embodiment, a terminal phosphate group is present at the 5'-end of sequence Y. In one embodiment, a terminal phosphate group is present at the 5'-end of sequence Y'. In one embodiment, W connects sequences Y and Y' via a biodegradable linker. In one embodiment, W further comprises a conjugate, label, aptamer, ligand, lipid, or polymer.

In one embodiment, regions X and Y of multifunctional siNA molecule of the invention (e.g., having any of Formula MF-I - MF-V), are complementary to different target nucleic acid sequences that are portions of the same target nucleic acid molecule. In one embodiment, such target nucleic acid sequences are at different locations within the coding region of a RNA transcript. In one embodiment, such target nucleic acid sequences comprise coding and non-coding regions of the same RNA transcript. In one embodiment, such target nucleic acid sequences comprise regions of alternately spliced transcripts or precursors of such alternately spliced transcripts.

In one embodiment, a multifunctional siNA molecule having any of Formula MF-I - MF-V can comprise chemical modifications as described herein without limitation, such as, for example, nucleotides having any of Formulae I-VII described herein, stabilization chemistries as described in **Table IV**, or any other combination of modified nucleotides and non-nucleotides as described in the various embodiments herein.

In one embodiment, the palidrome or repeat sequence or modified nucleotide (e.g., nucleotide with a modified base, such as 2-amino purine or a universal base) in Z of multifunctional siNA constructs having Formula MF-I or MF-II comprises chemically

modified nucleotides that are able to interact with a portion of the target nucleic acid sequence (e.g., modified base analogs that can form Watson Crick base pairs or non-Watson Crick base pairs).

In one embodiment, a multifunctional siNA molecule of the invention, for example  
5 each strand of a multifunctional siNA having MF-I – MF-V, independently comprises about 15 to about 40 nucleotides (e.g., about 15, 16, 17, 18, 19, 20, 21, 22, 23, 24, 25, 26, 27, 28, 29, 30, 31, 32, 33, 34, 35, 36, 37, 38, 39, or 40 nucleotides). In one embodiment, a multifunctional siNA molecule of the invention comprises one or more chemical modifications. In a non-limiting example, the introduction of chemically modified  
10 nucleotides and/or non-nucleotides into nucleic acid molecules of the invention provides a powerful tool in overcoming potential limitations of *in vivo* stability and bioavailability inherent to unmodified RNA molecules that are delivered exogenously. For example, the use of chemically modified nucleic acid molecules can enable a lower dose of a particular nucleic acid molecule for a given therapeutic effect since chemically modified nucleic acid  
15 molecules tend to have a longer half-life in serum or in cells or tissues. Furthermore, certain chemical modifications can improve the bioavailability and/or potency of nucleic acid molecules by not only enhancing half-life but also facilitating the targeting of nucleic acid molecules to particular organs, cells or tissues and/or improving cellular uptake of the nucleic acid molecules. Therefore, even if the activity of a chemically modified nucleic  
20 acid molecule is reduced *in vitro* as compared to a native/unmodified nucleic acid molecule, for example when compared to an unmodified RNA molecule, the overall activity of the modified nucleic acid molecule can be greater than the native or unmodified nucleic acid molecule due to improved stability, potency, duration of effect, bioavailability and/or delivery of the molecule.

25 In another embodiment, the invention features multifunctional siNAs, wherein the multifunctional siNAs are assembled from two separate double-stranded siNAs, with one of the ends of each sense strand is tethered to the end of the sense strand of the other siNA molecule, such that the two antisense siNA strands are annealed to their corresponding sense strand that are tethered to each other at one end (see **Figure 112**). The tethers or  
30 linkers can be nucleotide-based linkers or non-nucleotide based linkers as generally known in the art and as described herein.

In one embodiment, the invention features a multifunctional siNA, wherein the multifunctional siNA is assembled from two separate double-stranded siNAs, with the 5'-end of one sense strand of the siNA is tethered to the 5'- end of the sense strand of the other siNA molecule, such that the 5'-ends of the two antisense siNA strands, annealed to their corresponding sense strand that are tethered to each other at one end, point away (in the opposite direction) from each other (see **Figure 112 (A)**). The tethers or linkers can be nucleotide-based linkers or non-nucleotide based linkers as generally known in the art and as described herein.

In one embodiment, the invention features a multifunctional siNA, wherein the multifunctional siNA is assembled from two separate double-stranded siNAs, with the 3'-end of one sense strand of the siNA is tethered to the 3'- end of the sense strand of the other siNA molecule, such that the 5'-ends of the two antisense siNA strands, annealed to their corresponding sense strand that are tethered to each other at one end, face each other (see **Figure 112 (B)**). The tethers or linkers can be nucleotide-based linkers or non-nucleotide based linkers as generally known in the art and as described herein.

In one embodiment, the invention features a multifunctional siNA, wherein the multifunctional siNA is assembled from two separate double-stranded siNAs, with the 5'-end of one sense strand of the siNA is tethered to the 3'- end of the sense strand of the other siNA molecule, such that the 5'-end of the one of the antisense siNA strands annealed to their corresponding sense strand that are tethered to each other at one end, faces the 3'-end of the other antisense strand (see **Figure 112 (C-D)**). The tethers or linkers can be nucleotide-based linkers or non-nucleotide based linkers as generally known in the art and as described herein.

In one embodiment, the invention features a multifunctional siNA, wherein the multifunctional siNA is assembled from two separate double-stranded siNAs, with the 5'-end of one antisense strand of the siNA is tethered to the 3'- end of the antisense strand of the other siNA molecule, such that the 5'-end of the one of the sense siNA strands annealed to their corresponding antisense sense strand that are tethered to each other at one end, faces the 3'-end of the other sense strand (see **Figure 112 (G-H)**). In one embodiment, the linkage between the 5'-end of the first antisense strand and the 3'-end of the second antisense strand is designed in such a way as to be readily cleavable (e.g., biodegradable

linker) such that the 5' end of each antisense strand of the multifunctional siNA has a free 5'-end suitable to mediate RNA interference-based cleavage of the target RNA. The tethers or linkers can be nucleotide-based linkers or non-nucleotide based linkers as generally known in the art and as described herein.

5           In one embodiment, the invention features a multifunctional siNA, wherein the multifunctional siNA is assembled from two separate double-stranded siNAs, with the 5'-end of one antisense strand of the siNA is tethered to the 5'- end of the antisense strand of the other siNA molecule, such that the 3'-end of the one of the sense siNA strands annealed to their corresponding antisense sense strand that are tethered to each other at one  
10           end, faces the 3'-end of the other sense strand (see **Figure 112 (E)**). In one embodiment, the linkage between the 5'-end of the first antisense strand and the 5'-end of the second antisense strand is designed in such a way as to be readily cleavable (e.g., biodegradable linker) such that the 5' end of each antisense strand of the multifunctional siNA has a free  
15           5'-end suitable to mediate RNA interference-based cleavage of the target RNA. The tethers or linkers can be nucleotide-based linkers or non-nucleotide based linkers as generally known in the art and as described herein.

          In one embodiment, the invention features a multifunctional siNA, wherein the multifunctional siNA is assembled from two separate double-stranded siNAs, with the 3'-end of one antisense strand of the siNA is tethered to the 3'- end of the antisense strand  
20           of the other siNA molecule, such that the 5'-end of the one of the sense siNA strands annealed to their corresponding antisense sense strand that are tethered to each other at one end, faces the 3'-end of the other sense strand (see **Figure 112 (F)**). In one embodiment, the linkage between the 5'-end of the first antisense strand and the 5'-end of the second antisense strand is designed in such a way as to be readily cleavable (e.g., biodegradable  
25           linker) such that the 5' end of each antisense strand of the multifunctional siNA has a free 5'-end suitable to mediate RNA interference-based cleavage of the target RNA. The tethers or linkers can be nucleotide-based linkers or non-nucleotide based linkers as generally known in the art and as described herein.

          There are several potential advantages and variations to this multifunctional  
30           approach. For example, when used in combination with target sites having homology, siNAs that target a sequence present in two genes (e.g. Flt-1 site 3646, which targets



VEGF-R1 and R2), the design can be used to target more than two sites. A single multifunctional siNA can be for example, used to target VEGF R1 RNA and VEGF R2 RNA (using one antisense strand of the multifunctional siNA targeting of conserved sequence between to the two RNAs) and VEGF RNA (using the second antisense strand of the multifunctional siNA targeting VEGF RNA. This approach allows targeting of the cytokines and the two main receptors using a single multifunctional siNA.

#### Synthesis of Nucleic acid Molecules

Synthesis of nucleic acids greater than 100 nucleotides in length is difficult using automated methods, and the therapeutic cost of such molecules is prohibitive. In this invention, small nucleic acid motifs ("small" refers to nucleic acid motifs no more than 100 nucleotides in length, preferably no more than 80 nucleotides in length, and most preferably no more than 50 nucleotides in length; *e.g.*, individual siNA oligonucleotide sequences or siNA sequences synthesized in tandem) are preferably used for exogenous delivery. The simple structure of these molecules increases the ability of the nucleic acid to invade targeted regions of protein and/or RNA structure. Exemplary molecules of the instant invention are chemically synthesized, and others can similarly be synthesized.

Oligonucleotides (*e.g.*, certain modified oligonucleotides or portions of oligonucleotides lacking ribonucleotides) are synthesized using protocols known in the art, for example as described in Caruthers *et al.*, 1992, *Methods in Enzymology* 211, 3-19, Thompson *et al.*, International PCT Publication No. WO 99/54459, Wincott *et al.*, 1995, *Nucleic Acids Res.* 23, 2677-2684, Wincott *et al.*, 1997, *Methods Mol. Bio.*, 74, 59, Brennan *et al.*, 1998, *Biotechnol Bioeng.*, 61, 33-45, and Brennan, U.S. Pat. No. 6,001,311. All of these references are incorporated herein by reference. The synthesis of oligonucleotides makes use of common nucleic acid protecting and coupling groups, such as dimethoxytrityl at the 5'-end, and phosphoramidites at the 3'-end. In a non-limiting example, small scale syntheses are conducted on a 394 Applied Biosystems, Inc. synthesizer using a 0.2  $\mu$ mol scale protocol with a 2.5 min coupling step for 2'-O-methylated nucleotides and a 45 second coupling step for 2'-deoxy nucleotides or 2'-deoxy-2'-fluoro nucleotides. **Table V** outlines the amounts and the contact times of the reagents used in the synthesis cycle. Alternatively, syntheses at the 0.2  $\mu$ mol scale can be performed on a 96-well plate synthesizer, such as the instrument produced by Protogene

(Palo Alto, CA) with minimal modification to the cycle. A 33-fold excess (60  $\mu\text{L}$  of 0.11 M = 6.6  $\mu\text{mol}$ ) of 2'-O-methyl phosphoramidite and a 105-fold excess of S-ethyl tetrazole (60  $\mu\text{L}$  of 0.25 M = 15  $\mu\text{mol}$ ) can be used in each coupling cycle of 2'-O-methyl residues relative to polymer-bound 5'-hydroxyl. A 22-fold excess (40  $\mu\text{L}$  of 0.11 M = 4.4  $\mu\text{mol}$ ) of  
5 deoxy phosphoramidite and a 70-fold excess of S-ethyl tetrazole (40  $\mu\text{L}$  of 0.25 M = 10  $\mu\text{mol}$ ) can be used in each coupling cycle of deoxy residues relative to polymer-bound 5'-hydroxyl. Average coupling yields on the 394 Applied Biosystems, Inc. synthesizer, determined by colorimetric quantitation of the trityl fractions, are typically 97.5-99%. Other oligonucleotide synthesis reagents for the 394 Applied Biosystems, Inc. synthesizer  
10 include the following: detritylation solution is 3% TCA in methylene chloride (ABI); capping is performed with 16% *N*-methyl imidazole in THF (ABI) and 10% acetic anhydride/10% 2,6-lutidine in THF (ABI); and oxidation solution is 16.9 mM  $\text{I}_2$ , 49 mM pyridine, 9% water in THF (PERSEPTIVE™). Burdick & Jackson Synthesis Grade acetonitrile is used directly from the reagent bottle. S-Ethyltetrazole solution (0.25 M in  
15 acetonitrile) is made up from the solid obtained from American International Chemical, Inc. Alternately, for the introduction of phosphorothioate linkages, Beaucage reagent (3H-1,2-Benzodithiol-3-one 1,1-dioxide, 0.05 M in acetonitrile) is used.

Deprotection of the DNA-based oligonucleotides is performed as follows: the polymer-bound trityl-on oligoribonucleotide is transferred to a 4 mL glass screw top vial  
20 and suspended in a solution of 40% aqueous methylamine (1 mL) at 65 °C for 10 minutes. After cooling to -20 °C, the supernatant is removed from the polymer support. The support is washed three times with 1.0 mL of EtOH:MeCN:H<sub>2</sub>O/3:1:1, vortexed and the supernatant is then added to the first supernatant. The combined supernatants, containing the oligoribonucleotide, are dried to a white powder.

25 The method of synthesis used for RNA including certain siNA molecules of the invention follows the procedure as described in Usman *et al.*, 1987, *J. Am. Chem. Soc.*, 109, 7845; Scaringe *et al.*, 1990, *Nucleic Acids Res.*, 18, 5433; and Wincott *et al.*, 1995, *Nucleic Acids Res.* 23, 2677-2684 Wincott *et al.*, 1997, *Methods Mol. Bio.*, 74, 59, and makes use of common nucleic acid protecting and coupling groups, such as dimethoxytrityl at the  
30 5'-end, and phosphoramidites at the 3'-end. In a non-limiting example, small scale syntheses are conducted on a 394 Applied Biosystems, Inc. synthesizer using a 0.2  $\mu\text{mol}$  scale protocol with a 7.5 min coupling step for alkylsilyl protected nucleotides and a 2.5

min coupling step for 2'-O-methylated nucleotides. **Table V** outlines the amounts and the contact times of the reagents used in the synthesis cycle. Alternatively, syntheses at the 0.2  $\mu\text{mol}$  scale can be done on a 96-well plate synthesizer, such as the instrument produced by Protogene (Palo Alto, CA) with minimal modification to the cycle. A 33-fold excess (60  $\mu\text{L}$  of 0.11 M = 6.6  $\mu\text{mol}$ ) of 2'-O-methyl phosphoramidite and a 75-fold excess of S-ethyl tetrazole (60  $\mu\text{L}$  of 0.25 M = 15  $\mu\text{mol}$ ) can be used in each coupling cycle of 2'-O-methyl residues relative to polymer-bound 5'-hydroxyl. A 66-fold excess (120  $\mu\text{L}$  of 0.11 M = 13.2  $\mu\text{mol}$ ) of alkylsilyl (ribo) protected phosphoramidite and a 150-fold excess of S-ethyl tetrazole (120  $\mu\text{L}$  of 0.25 M = 30  $\mu\text{mol}$ ) can be used in each coupling cycle of ribo residues relative to polymer-bound 5'-hydroxyl. Average coupling yields on the 394 Applied Biosystems, Inc. synthesizer, determined by colorimetric quantitation of the trityl fractions, are typically 97.5-99%. Other oligonucleotide synthesis reagents for the 394 Applied Biosystems, Inc. synthesizer include the following: detritylation solution is 3% TCA in methylene chloride (ABI); capping is performed with 16% *N*-methyl imidazole in THF (ABI) and 10% acetic anhydride/10% 2,6-lutidine in THF (ABI); oxidation solution is 16.9 mM  $\text{I}_2$ , 49 mM pyridine, 9% water in THF (PERSEPTIVE™). Burdick & Jackson Synthesis Grade acetonitrile is used directly from the reagent bottle. S-Ethyltetrazole solution (0.25 M in acetonitrile) is made up from the solid obtained from American International Chemical, Inc. Alternately, for the introduction of phosphorothioate linkages, Beaucage reagent (3H-1,2-Benzodithiol-3-one 1,1-dioxide 0.05 M in acetonitrile) is used.

Deprotection of the RNA is performed using either a two-pot or one-pot protocol. For the two-pot protocol, the polymer-bound trityl-on oligoribonucleotide is transferred to a 4 mL glass screw top vial and suspended in a solution of 40% aq. methylamine (1 mL) at 65 °C for 10 minutes. After cooling to -20 °C, the supernatant is removed from the polymer support. The support is washed three times with 1.0 mL of EtOH:MeCN:H<sub>2</sub>O/3:1:1, vortexed and the supernatant is then added to the first supernatant. The combined supernatants, containing the oligoribonucleotide, are dried to a white powder. The base deprotected oligoribonucleotide is resuspended in anhydrous TEA/HF/NMP solution (300  $\mu\text{L}$  of a solution of 1.5 mL *N*-methylpyrrolidinone, 750  $\mu\text{L}$  TEA and 1 mL TEA•3HF to provide a 1.4 M HF concentration) and heated to 65 °C. After 1.5 h, the oligomer is quenched with 1.5 M  $\text{NH}_4\text{HCO}_3$ .

Alternatively, for the one-pot protocol, the polymer-bound trityl-on oligoribonucleotide is transferred to a 4 mL glass screw top vial and suspended in a solution of 33% ethanolic methylamine/DMSO: 1/1 (0.8 mL) at 65 °C for 15 minutes. The vial is brought to room temperature TEA•3HF (0.1 mL) is added and the vial is heated at 65 °C for  
5 15 minutes. The sample is cooled at -20 °C and then quenched with 1.5 M NH<sub>4</sub>HCO<sub>3</sub>.

For purification of the trityl-on oligomers, the quenched NH<sub>4</sub>HCO<sub>3</sub> solution is loaded onto a C-18 containing cartridge that had been prewashed with acetonitrile followed by 50 mM TEAA. After washing the loaded cartridge with water, the RNA is detritylated with 0.5% TFA for 13 minutes. The cartridge is then washed again with water, salt exchanged  
10 with 1 M NaCl and washed with water again. The oligonucleotide is then eluted with 30% acetonitrile.

The average stepwise coupling yields are typically >98% (Wincott *et al.*, 1995 *Nucleic Acids Res.* 23, 2677-2684). Those of ordinary skill in the art will recognize that the scale of synthesis can be adapted to be larger or smaller than the example described  
15 above including but not limited to 96-well format.

Alternatively, the nucleic acid molecules of the present invention can be synthesized separately and joined together post-synthetically, for example, by ligation (Moore *et al.*, 1992, *Science* 256, 9923; Draper *et al.*, International PCT publication No. WO 93/23569; Shabarova *et al.*, 1991, *Nucleic Acids Research* 19, 4247; Bellon *et al.*, 1997, *Nucleosides & Nucleotides*, 16, 951; Bellon *et al.*, 1997, *Bioconjugate Chem.* 8, 204), or by  
20 hybridization following synthesis and/or deprotection.

The siNA molecules of the invention can also be synthesized via a tandem synthesis methodology as described in Example 1 herein, wherein both siNA strands are synthesized as a single contiguous oligonucleotide fragment or strand separated by a cleavable linker  
25 which is subsequently cleaved to provide separate siNA fragments or strands that hybridize and permit purification of the siNA duplex. The linker can be a polynucleotide linker or a non-nucleotide linker. The tandem synthesis of siNA as described herein can be readily adapted to both multiwell/multiplate synthesis platforms such as 96 well or similarly larger multi-well platforms. The tandem synthesis of siNA as described herein can also be readily

adapted to large scale synthesis platforms employing batch reactors, synthesis columns and the like.

A siNA molecule can also be assembled from two distinct nucleic acid strands or fragments wherein one fragment includes the sense region and the second fragment  
5 includes the antisense region of the RNA molecule.

The nucleic acid molecules of the present invention can be modified extensively to enhance stability by modification with nuclease resistant groups, for example, 2'-amino, 2'-C-allyl, 2'-fluoro, 2'-O-methyl, 2'-H (for a review see Usman and Cedergren, 1992, *TIBS* 17, 34; Usman *et al.*, 1994, *Nucleic Acids Symp. Ser.* 31, 163). siNA constructs can be  
10 purified by gel electrophoresis using general methods or can be purified by high pressure liquid chromatography (HPLC; see Wincott *et al.*, *supra*, the totality of which is hereby incorporated herein by reference) and re-suspended in water.

In another aspect of the invention, siNA molecules of the invention are expressed from transcription units inserted into DNA or RNA vectors. The recombinant vectors can  
15 be DNA plasmids or viral vectors. siNA expressing viral vectors can be constructed based on, but not limited to, adeno-associated virus, retrovirus, adenovirus, or alphavirus. The recombinant vectors capable of expressing the siNA molecules can be delivered as described herein, and persist in target cells. Alternatively, viral vectors can be used that provide for transient expression of siNA molecules.

20 Optimizing Activity of the nucleic acid molecule of the invention.

Chemically synthesizing nucleic acid molecules with modifications (base, sugar and/or phosphate) can prevent their degradation by serum ribonucleases, which can increase their potency (see *e.g.*, Eckstein *et al.*, International Publication No. WO 92/07065; Perrault *et al.*, 1990 *Nature* 344, 565; Pieken *et al.*, 1991, *Science* 253, 314;  
25 Usman and Cedergren, 1992, *Trends in Biochem. Sci.* 17, 334; Usman *et al.*, International Publication No. WO 93/15187; and Rossi *et al.*, International Publication No. WO 91/03162; Sproat, U.S. Pat. No. 5,334,711; Gold *et al.*, U.S. Pat. No. 6,300,074; and Burgin *et al.*, *supra*; all of which are incorporated by reference herein). All of the above references describe various chemical modifications that can be made to the base, phosphate and/or  
30 sugar moieties of the nucleic acid molecules described herein. Modifications that enhance

their efficacy in cells, and removal of bases from nucleic acid molecules to shorten oligonucleotide synthesis times and reduce chemical requirements are desired.

There are several examples in the art describing sugar, base and phosphate modifications that can be introduced into nucleic acid molecules with significant enhancement in their nuclease stability and efficacy. For example, oligonucleotides are modified to enhance stability and/or enhance biological activity by modification with nuclease resistant groups, for example, 2'-amino, 2'-C-allyl, 2'-fluoro, 2'-O-methyl, 2'-O-allyl, 2'-H, nucleotide base modifications (for a review see Usman and Cedergren, 1992, *TIBS*, 17, 34; Usman *et al.*, 1994, *Nucleic Acids Symp. Ser.* 31, 163; Burgin *et al.*, 1996, *Biochemistry*, 35, 14090). Sugar modification of nucleic acid molecules have been extensively described in the art (see Eckstein *et al.*, *International Publication* PCT No. WO 92/07065; Perrault *et al.* *Nature*, 1990, 344, 565-568; Pieken *et al.* *Science*, 1991, 253, 314-317; Usman and Cedergren, *Trends in Biochem. Sci.*, 1992, 17, 334-339; Usman *et al.* *International Publication* PCT No. WO 93/15187; Sproat, *U.S. Pat.* No. 5,334,711 and Beigelman *et al.*, 1995, *J. Biol. Chem.*, 270, 25702; Beigelman *et al.*, *International PCT publication* No. WO 97/26270; Beigelman *et al.*, *U.S. Pat.* No. 5,716,824; Usman *et al.*, *U.S. Pat.* No. 5,627,053; Woolf *et al.*, *International PCT Publication* No. WO 98/13526; Thompson *et al.*, *USSN* 60/082,404 which was filed on April 20, 1998; Karpeisky *et al.*, 1998, *Tetrahedron Lett.*, 39, 1131; Earnshaw and Gait, 1998, *Biopolymers (Nucleic Acid Sciences)*, 48, 39-55; Verma and Eckstein, 1998, *Annu. Rev. Biochem.*, 67, 99-134; and Burlina *et al.*, 1997, *Bioorg. Med. Chem.*, 5, 1999-2010; all of the references are hereby incorporated in their totality by reference herein). Such publications describe general methods and strategies to determine the location of incorporation of sugar, base and/or phosphate modifications and the like into nucleic acid molecules without modulating catalysis, and are incorporated by reference herein. In view of such teachings, similar modifications can be used as described herein to modify the siNA nucleic acid molecules of the instant invention so long as the ability of siNA to promote RNAi in cells is not significantly inhibited.

While chemical modification of oligonucleotide internucleotide linkages with phosphorothioate, phosphorodithioate, and/or 5'-methylphosphonate linkages improves stability, excessive modifications can cause some toxicity or decreased activity. Therefore, when designing nucleic acid molecules, the amount of these internucleotide linkages

should be minimized. The reduction in the concentration of these linkages should lower toxicity, resulting in increased efficacy and higher specificity of these molecules.

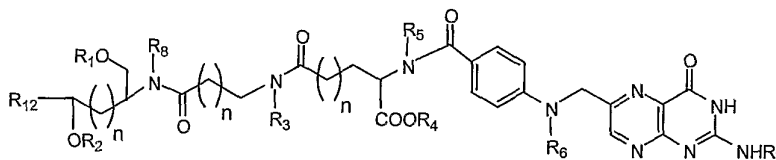
Short interfering nucleic acid (siNA) molecules having chemical modifications that maintain or enhance activity are provided. Such a nucleic acid is also generally more resistant to nucleases than an unmodified nucleic acid. Accordingly, the *in vitro* and/or *in vivo* activity should not be significantly lowered. In cases in which modulation is the goal, therapeutic nucleic acid molecules delivered exogenously should optimally be stable within cells until translation of the target RNA has been modulated long enough to reduce the levels of the undesirable protein. This period of time varies between hours to days depending upon the disease state. Improvements in the chemical synthesis of RNA and DNA (Wincott *et al.*, 1995, *Nucleic Acids Res.* 23, 2677; Caruthers *et al.*, 1992, *Methods in Enzymology* 211,3-19 (incorporated by reference herein)) have expanded the ability to modify nucleic acid molecules by introducing nucleotide modifications to enhance their nuclease stability, as described above.

In one embodiment, nucleic acid molecules of the invention include one or more (*e.g.*, about 1, 2, 3, 4, 5, 6, 7, 8, 9, 10, or more) G-clamp nucleotides. A G-clamp nucleotide is a modified cytosine analog wherein the modifications confer the ability to hydrogen bond both Watson-Crick and Hoogsteen faces of a complementary guanine within a duplex, see for example Lin and Matteucci, 1998, *J. Am. Chem. Soc.*, 120, 8531-8532. A single G-clamp analog substitution within an oligonucleotide can result in substantially enhanced helical thermal stability and mismatch discrimination when hybridized to complementary oligonucleotides. The inclusion of such nucleotides in nucleic acid molecules of the invention results in both enhanced affinity and specificity to nucleic acid targets, complementary sequences, or template strands. In another embodiment, nucleic acid molecules of the invention include one or more (*e.g.*, about 1, 2, 3, 4, 5, 6, 7, 8, 9, 10, or more) LNA "locked nucleic acid" nucleotides such as a 2', 4'-C methylene bicyclo nucleotide (see for example Wengel *et al.*, International PCT Publication No. WO 00/66604 and WO 99/14226).

In another embodiment, the invention features conjugates and/or complexes of siNA molecules of the invention. Such conjugates and/or complexes can be used to facilitate delivery of siNA molecules into a biological system, such as a cell. The conjugates and

complexes provided by the instant invention can impart therapeutic activity by transferring therapeutic compounds across cellular membranes, altering the pharmacokinetics, and/or modulating the localization of nucleic acid molecules of the invention. The present invention encompasses the design and synthesis of novel conjugates and complexes for the delivery of molecules, including, but not limited to, small molecules, lipids, cholesterol, phospholipids, nucleosides, nucleotides, nucleic acids, antibodies, toxins, negatively charged polymers and other polymers, for example, proteins, peptides, hormones, carbohydrates, polyethylene glycols, or polyamines, across cellular membranes. In general, the transporters described are designed to be used either individually or as part of a multi-component system, with or without degradable linkers. These compounds are expected to improve delivery and/or localization of nucleic acid molecules of the invention into a number of cell types originating from different tissues, in the presence or absence of serum (see Sullenger and Cech, U.S. Pat. No. 5,854,038). Conjugates of the molecules described herein can be attached to biologically active molecules via linkers that are biodegradable, such as biodegradable nucleic acid linker molecules.

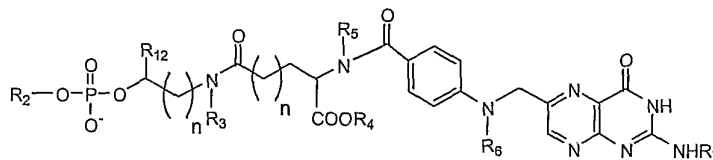
In one embodiment, the invention features a compound having Formula 1:



1

wherein each  $R_1$ ,  $R_3$ ,  $R_4$ ,  $R_5$ ,  $R_6$ ,  $R_7$  and  $R_8$  is independently hydrogen, alkyl, substituted alkyl, aryl, substituted aryl, or a protecting group, each "n" is independently an integer from 0 to about 200,  $R_{12}$  is a straight or branched chain alkyl, substituted alkyl, aryl, or substituted aryl, and  $R_2$  is a siNA molecule or a portion thereof.

In one embodiment, the invention features a compound having Formula 2:



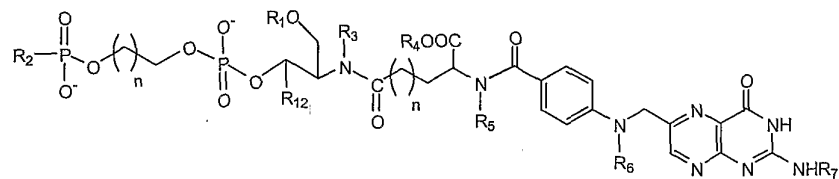
2

25



wherein each  $R_3$ ,  $R_4$ ,  $R_5$ ,  $R_6$  and  $R_7$  is independently hydrogen, alkyl, substituted alkyl, aryl, substituted aryl, or a protecting group, each "n" is independently an integer from 0 to about 200,  $R_{12}$  is a straight or branched chain alkyl, substituted alkyl, aryl, or substituted aryl, and  $R_2$  is a siNA molecule or a portion thereof.

5 In one embodiment, the invention features a compound having Formula 3:

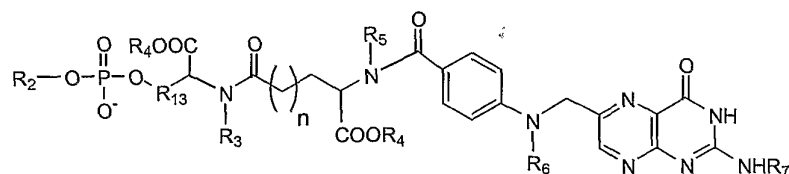


3

wherein each  $R_1$ ,  $R_3$ ,  $R_4$ ,  $R_5$ ,  $R_6$  and  $R_7$  is independently hydrogen, alkyl, substituted alkyl, aryl, substituted aryl, or a protecting group, each "n" is independently an integer from 0 to about 200,  $R_{12}$  is a straight or branched chain alkyl, substituted alkyl, aryl, or substituted aryl, and  $R_2$  is a siNA molecule or a portion thereof.

10

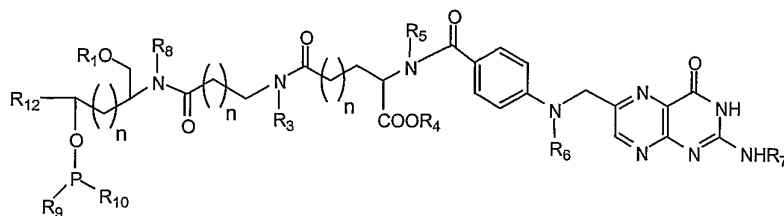
In one embodiment, the invention features a compound having Formula 4:



4

15 wherein each  $R_3$ ,  $R_4$ ,  $R_5$ ,  $R_6$  and  $R_7$  is independently hydrogen, alkyl, substituted alkyl, aryl, substituted aryl, or a protecting group, each "n" is independently an integer from 0 to about 200,  $R_2$  is a siNA molecule or a portion thereof, and  $R_{13}$  is an amino acid side chain.

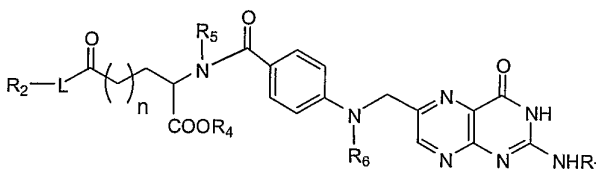
In one embodiment, the invention features a compound having Formula 5:



5

wherein each  $R_1$  and  $R_4$  is independently a protecting group or hydrogen, each  $R_3$ ,  $R_5$ ,  $R_6$ ,  $R_7$  and  $R_8$  is independently hydrogen, alkyl or nitrogen protecting group, each “ $n$ ” is independently an integer from 0 to about 200,  $R_{12}$  is a straight or branched chain alkyl, substituted alkyl, aryl, or substituted aryl, and each  $R_9$  and  $R_{10}$  is independently a nitrogen containing group, cyanoalkoxy, alkoxy, aryloxy, or alkyl group.

In one embodiment, the invention features a compound having Formula 6:

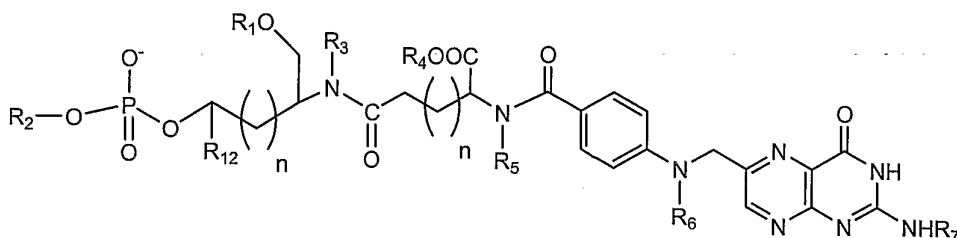


6

10

wherein each  $R_4$ ,  $R_5$ ,  $R_6$  and  $R_7$  is independently hydrogen, alkyl, substituted alkyl, aryl, substituted aryl, or a protecting group,  $R_2$  is a siNA molecule or a portion thereof, each “ $n$ ” is independently an integer from 0 to about 200, and L is a degradable linker.

In one embodiment, the invention features a compound having Formula 7:



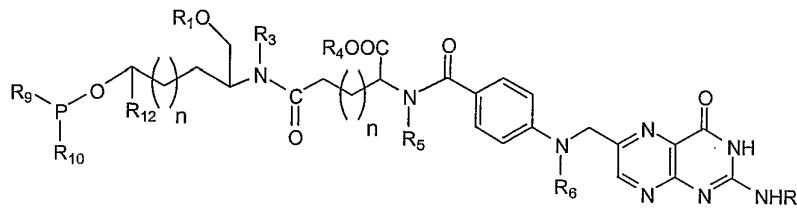
7

15

wherein each  $R_1$ ,  $R_3$ ,  $R_4$ ,  $R_5$ ,  $R_6$  and  $R_7$  is independently hydrogen, alkyl, substituted alkyl, aryl, substituted aryl, or a protecting group, each “ $n$ ” is independently an integer

from 0 to about 200,  $R_{12}$  is a straight or branched chain alkyl, substituted alkyl, aryl, or substituted aryl, and  $R_2$  is a siNA molecule or a portion thereof.

In one embodiment, the invention features a compound having Formula 8:



5

8

wherein each  $R_1$  and  $R_4$  is independently a protecting group or hydrogen, each  $R_3$ ,  $R_5$ ,  $R_6$  and  $R_7$  is independently hydrogen, alkyl or nitrogen protecting group, each "n" is independently an integer from 0 to about 200,  $R_{12}$  is a straight or branched chain alkyl, substituted alkyl, aryl, or substituted aryl, and each  $R_9$  and  $R_{10}$  is independently a nitrogen containing group, cyanoalkoxy, alkoxy, aryloxy, or alkyl group.

In one embodiment,  $R_{13}$  of a compound of the invention comprises an alkylamino or an alkoxy group, for example,  $-\text{CH}_2\text{O}-$  or  $-\text{CH}(\text{CH}_2)\text{CH}_2\text{O}-$ .

In another embodiment,  $R_{12}$  of a compound of the invention is an alkylhydroxyl, for example,  $-(\text{CH}_2)_n\text{OH}$ , where n comprises an integer from about 1 to about 10.

In another embodiment, L of Formula 6 of the invention comprises serine, threonine, or a photolabile linkage.

In one embodiment,  $R_9$  of a compound of the invention comprises a phosphorus protecting group, for example  $-\text{OCH}_2\text{CH}_2\text{CN}$  (oxyethylcyano).

In one embodiment,  $R_{10}$  of a compound of the invention comprises a nitrogen containing group, for example,  $-\text{N}(\text{R}_{14})$  wherein  $\text{R}_{14}$  is a straight or branched chain alkyl having from about 1 to about 10 carbons.

In another embodiment,  $R_{10}$  of a compound of the invention comprises a heterocycloalkyl or heterocycloalkenyl ring containing from about 4 to about 7 atoms, and having from about 1 to about 3 heteroatoms comprising oxygen, nitrogen, or sulfur.

In another embodiment,  $R_1$  of a compound of the invention comprises an acid labile protecting group, such as a trityl or substituted trityl group, for example, a dimethoxytrityl or mono-methoxytrityl group.

In another embodiment,  $R_4$  of a compound of the invention comprises a *tert*-butyl, 5 Fm (fluorenyl-methoxy), or allyl group.

In one embodiment,  $R_6$  of a compound of the invention comprises a TFA (trifluoroacetyl) group.

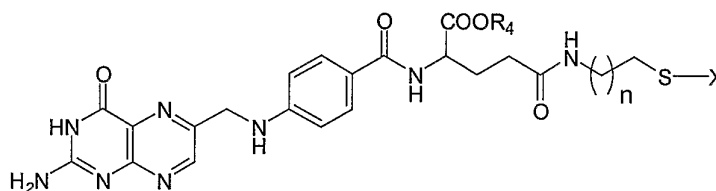
In another embodiment,  $R_3$ ,  $R_5$ ,  $R_7$  and  $R_8$  of a compound of the invention are independently hydrogen.

10 In one embodiment,  $R_7$  of a compound of the invention is independently isobutyryl, dimethylformamide, or hydrogen.

In another embodiment,  $R_{12}$  of a compound of the invention comprises a methyl group or ethyl group.

In one embodiment, the invention features a compound having Formula 27:

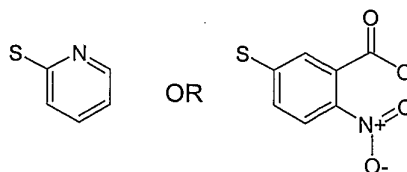
15



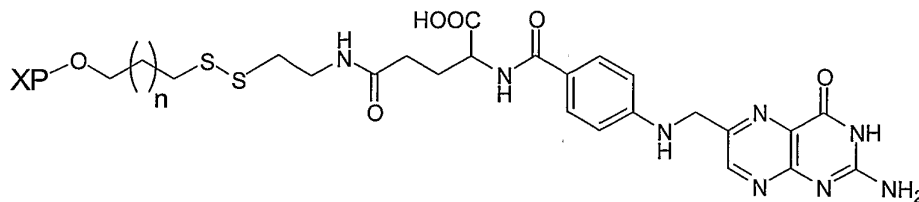
27

wherein "n" is an integer from about 0 to about 20,  $R_4$  is H or a cationic salt, X is a siNA molecule or a portion thereof, and  $R_{24}$  is a sulfur containing leaving group, for example a group comprising:

20



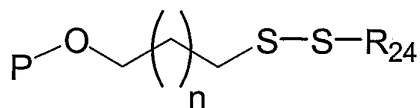
In one embodiment, the invention features a compound having Formula 39:



39

wherein "n" is an integer from about 0 to about 20, X is a siNA molecule or a portion thereof, and P is a phosphorus containing group.

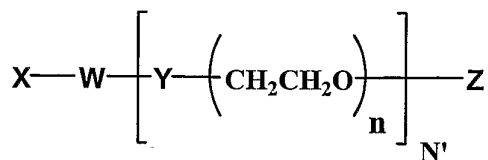
- 5 In another embodiment, a thiol containing linker of the invention is a compound having Formula 41:



41

- wherein "n" is an integer from about 0 to about 20, P is a phosphorus containing group, for example a phosphine, phosphite, or phosphate, and R<sub>24</sub> is any alkyl, substituted alkyl, alkoxy, aryl, substituted aryl, alkenyl, substituted alkenyl, alkynyl, or substituted alkynyl group with or without additional protecting groups.
- 10

In one embodiment, the invention features a compound having Formula 43:



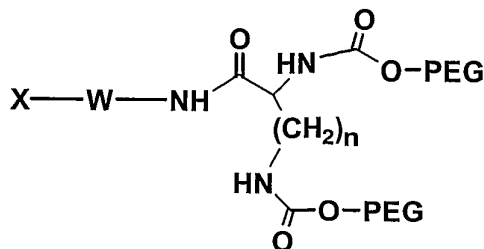
15

43

- wherein X comprises a siNA molecule or portion thereof; W comprises a degradable nucleic acid linker; Y comprises a linker molecule or amino acid that can be present or absent; Z comprises H, OH, O-alkyl, SH, S-alkyl, alkyl, substituted alkyl, aryl, substituted aryl, amino, substituted amino, nucleotide, nucleoside, nucleic acid, oligonucleotide, amino acid, peptide, protein, lipid, phospholipid, or label; n is an integer from about 1 to about 100; and N' is an integer from about 1 to about 20. In another
- 20

embodiment, W is selected from the group consisting of amide, phosphate, phosphate ester, phosphoramidate, or thiophosphate ester linkage.

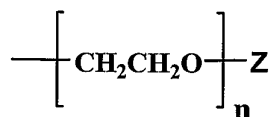
In another embodiment, the invention features a compound having Formula 44:



5

44

wherein X comprises a siNA molecule or portion thereof; W comprises a linker molecule or chemical linkage that can be present or absent; n is an integer from about 1 to about 50, and PEG represents a compound having Formula 45:



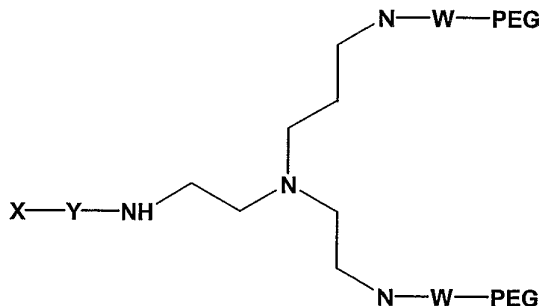
10

45

wherein Z comprises H, OH, O-alkyl, SH, S-alkyl, alkyl, substituted alkyl, aryl, substituted aryl, amino, substituted amino, nucleotide, nucleoside, nucleic acid, oligonucleotide, amino acid, peptide, protein, lipid, phospholipid, or label; and n is an integer from about 1 to about 100. In another embodiment, W is selected from the group consisting of amide, phosphate, phosphate ester, phosphoramidate, or thiophosphate ester linkage.

15

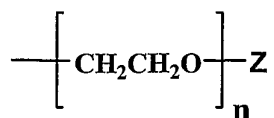
In another embodiment, the invention features a compound having Formula 46:



175

46

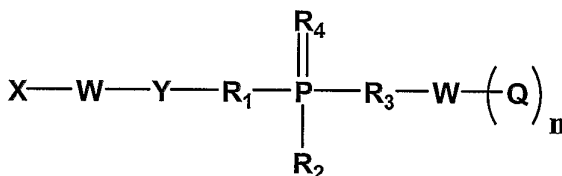
wherein X comprises a siNA molecule or portion thereof; each W independently comprises linker molecule or chemical linkage that can be present or absent, Y comprises a linker molecule or chemical linkage that can be present or absent; and PEG represents a compound having Formula 45:



45

wherein Z comprises H, OH, O-alkyl, SH, S-alkyl, alkyl, substituted alkyl, aryl, substituted aryl, amino, substituted amino, nucleotide, nucleoside, nucleic acid, oligonucleotide, amino acid, peptide, protein, lipid, phospholipid, or label; and n is an integer from about 1 to about 100. In another embodiment, W is selected from the group consisting of amide, phosphate, phosphate ester, phosphoramidate, or thiophosphate ester linkage.

In one embodiment, the invention features a compound having Formula 47:

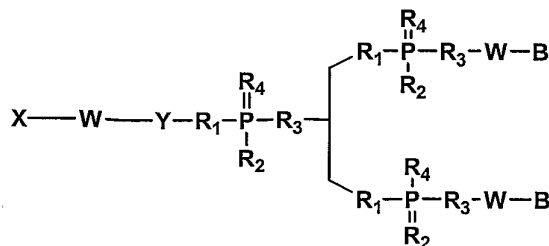


15

47

wherein X comprises a siNA molecule or portion thereof; each W independently comprises a linker molecule or chemical linkage that can be the same or different and can be present or absent, Y comprises a linker molecule that can be present or absent; each Q independently comprises a hydrophobic group or phospholipid; each R<sub>1</sub>, R<sub>2</sub>, R<sub>3</sub>, and R<sub>4</sub> independently comprises O, OH, H, alkyl, alkylhalo, O-alkyl, O-alkylcyano, S, S-alkyl, S-alkylcyano, N or substituted N, and n is an integer from about 1 to about 10. In another embodiment, W is selected from the group consisting of amide, phosphate, phosphate ester, phosphoramidate, or thiophosphate ester linkage.

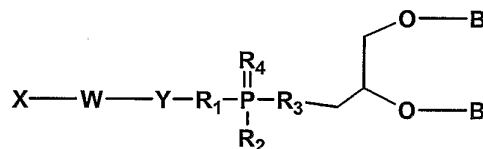
In another embodiment, the invention features a compound having Formula 48:



48

wherein X comprises a siNA molecule or portion thereof; each W independently comprises a linker molecule or chemical linkage that can be present or absent, Y comprises  
 5 a linker molecule that can be present or absent; each R<sub>1</sub>, R<sub>2</sub>, R<sub>3</sub>, and R<sub>4</sub> independently comprises O, OH, H, alkyl, alkylhalo, O-alkyl, O-alkylcyano, S, S-alkyl, S-alkylcyano, N or substituted N, and B represents a lipophilic group, for example a saturated or unsaturated linear, branched, or cyclic alkyl group, cholesterol, or a derivative thereof. In another embodiment, W is selected from the group consisting of amide, phosphate, phosphate ester,  
 10 phosphoramidate, or thiophosphate ester linkage.

In another embodiment, the invention features a compound having Formula 49:

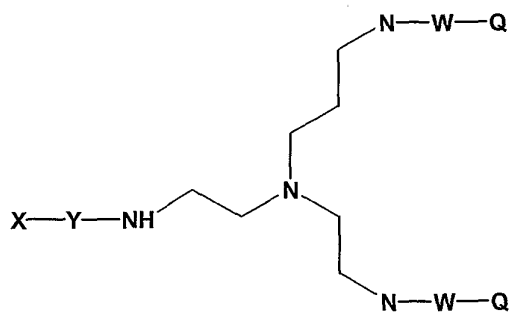


49

wherein X comprises a siNA molecule or portion thereof; W comprises a linker  
 15 molecule or chemical linkage that can be present or absent; Y comprises a linker molecule that can be present or absent; each R<sub>1</sub>, R<sub>2</sub>, R<sub>3</sub>, and R<sub>4</sub> independently comprises O, OH, H, alkyl, alkylhalo, O-alkyl, O-alkylcyano, S, S-alkyl, S-alkylcyano, N or substituted N, and B represents a lipophilic group, for example a saturated or unsaturated linear, branched, or cyclic alkyl group, cholesterol, or a derivative thereof. In another embodiment, W is  
 20 selected from the group consisting of amide, phosphate, phosphate ester, phosphoramidate, or thiophosphate ester linkage.

In another embodiment, the invention features a compound having Formula 50:

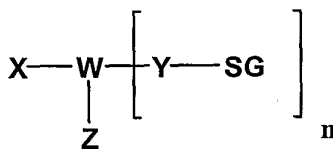




50

wherein X comprises a siNA molecule or portion thereof; W comprises a linker molecule or chemical linkage that can be present or absent, Y comprises a linker molecule  
 5 or chemical linkage that can be present or absent; and each Q independently comprises a hydrophobic group or phospholipid. In another embodiment, W is selected from the group consisting of amide, phosphate, phosphate ester, phosphoramidate, or thiophosphate ester linkage.

In one embodiment, the invention features a compound having Formula 51:

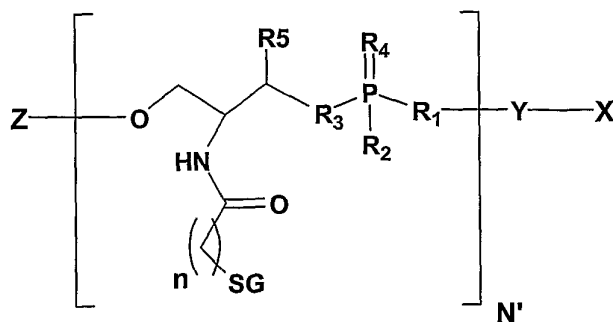


10

51

wherein X comprises a siNA molecule or portion thereof; W comprises a linker molecule or chemical linkage that can be present or absent; Y comprises a linker molecule  
 15 or amino acid that can be present or absent; Z comprises H, OH, O-alkyl, SH, S-alkyl, alkyl, substituted alkyl, aryl, substituted aryl, amino, substituted amino, nucleotide, nucleoside, nucleic acid, oligonucleotide, amino acid, peptide, protein, lipid, phospholipid, or label; SG comprises a sugar, for example galactose, galactosamine, N-acetyl-galactosamine, glucose, mannose, fructose, or fucose and the respective D or L, alpha or beta isomers, and n is an  
 20 integer from about 1 to about 20. In another embodiment, W is selected from the group consisting of amide, phosphate, phosphate ester, phosphoramidate, or thiophosphate ester linkage.

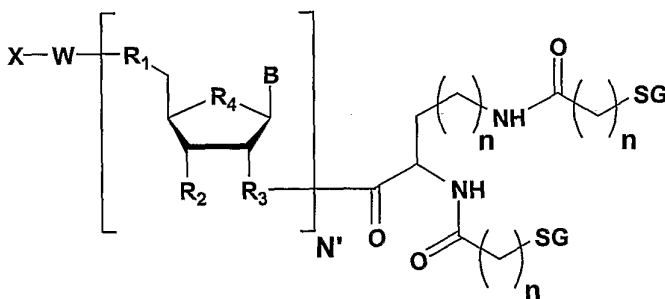
In another embodiment, the invention features a compound having Formula 52:



52

wherein X comprises a siNA molecule or portion thereof; Y comprises a linker molecule or chemical linkage that can be present or absent; each R<sub>1</sub>, R<sub>2</sub>, R<sub>3</sub>, R<sub>4</sub>, and R<sub>5</sub> independently comprises O, OH, H, alkyl, alkylhalo, O-alkyl, O-alkylcyano, S, S-alkyl, S-alkylcyano, N or substituted N; Z comprises H, OH, O-alkyl, SH, S-alkyl, alkyl, substituted alkyl, aryl, substituted aryl, amino, substituted amino, nucleotide, nucleoside, nucleic acid, oligonucleotide, amino acid, peptide, protein, lipid, phospholipid, or label; SG comprises a sugar, for example galactose, galactosamine, N-acetyl-galactosamine, glucose, mannose, fructose, or fucose and the respective D or L, alpha or beta isomers, n is an integer from about 1 to about 20; and N' is an integer from about 1 to about 20. In another embodiment, X comprises a siNA molecule or a portion thereof. In another embodiment, Y is selected from the group consisting of amide, phosphate, phosphate ester, phosphoramidate, or thiophosphate ester linkage.

In another embodiment, the invention features a compound having Formula 53:

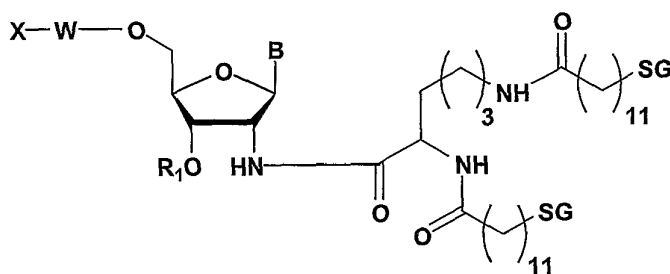


53

wherein B comprises H, a nucleoside base, or a non-nucleosidic base with or without protecting groups; each R<sub>1</sub> independently comprises O, N, S, alkyl, or substituted N; each R<sub>2</sub> independently comprises O, OH, H, alkyl, alkylhalo, O-alkyl, O-alkylhalo, S, N,

substituted N, or a phosphorus containing group; each R<sub>3</sub> independently comprises N or O-N, each R<sub>4</sub> independently comprises O, CH<sub>2</sub>, S, sulfone, or sulfoxy; X comprises H, a removable protecting group, a siNA molecule or a portion thereof; W comprises a linker molecule or chemical linkage that can be present or absent; SG comprises a sugar, for example galactose, galactosamine, N-acetyl-galactosamine, glucose, mannose, fructose, or fucose and the respective D or L, alpha or beta isomers,, each n is independently an integer from about 1 to about 50; and N' is an integer from about 1 to about 10. In another embodiment, W is selected from the group consisting of amide, phosphate, phosphate ester, phosphoramidate, or thiophosphate ester linkage.

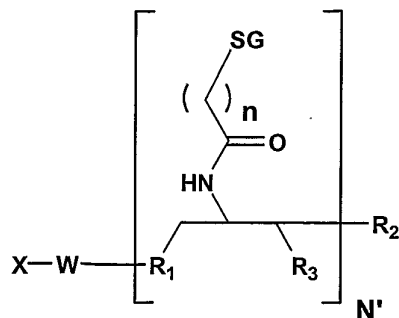
10 In another embodiment, the invention features a compound having Formula 54:



54

wherein B comprises H, a nucleoside base, or a non-nucleosidic base with or without protecting groups; each R<sub>1</sub> independently comprises O, OH, H, alkyl, alkylhalo, O-alkyl, O-alkylhalo, S, N, substituted N, or a phosphorus containing group; X comprises H, a removable protecting group, a siNA molecule or a portion thereof; W comprises a linker molecule or chemical linkage that can be present or absent; and SG comprises a sugar, for example galactose, galactosamine, N-acetyl-galactosamine, glucose, mannose, fructose, or fucose and the respective D or L, alpha or beta isomers. In another embodiment, W is selected from the group consisting of amide, phosphate, phosphate ester, phosphoramidate, or thiophosphate ester linkage.

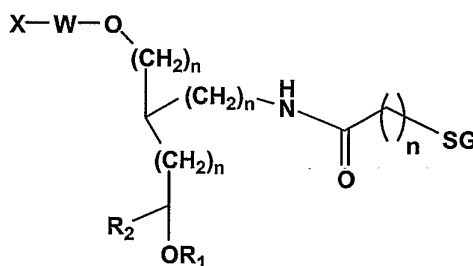
In one embodiment, the invention features a compound having Formula 55:



55

wherein each R<sub>1</sub> independently comprises O, N, S, alkyl, or substituted N; each R<sub>2</sub> independently comprises O, OH, H, alkyl, alkylhalo, O-alkyl, O-alkylhalo, S, N, substituted N, or a phosphorus containing group; each R<sub>3</sub> independently comprises H, OH, alkyl, substituted alkyl, or halo; X comprises H, a removable protecting group, a siNA molecule or a portion thereof; W comprises a linker molecule or chemical linkage that can be present or absent; SG comprises a sugar, for example galactose, galactosamine, N-acetyl-galactosamine, glucose, mannose, fructose, or fucose and the respective D or L, alpha or beta isomers, each n is independently an integer from about 1 to about 50; and N' is an integer from about 1 to about 100. In another embodiment, W is selected from the group consisting of amide, phosphate, phosphate ester, phosphoramidate, or thiophosphate ester linkage.

In another embodiment, the invention features a compound having Formula 56:

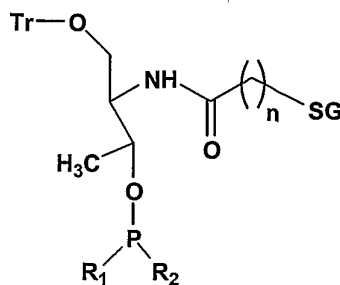


56

wherein R<sub>1</sub> comprises H, alkyl, alkylhalo, N, substituted N, or a phosphorus containing group; R<sub>2</sub> comprises H, O, OH, alkyl, alkylhalo, halo, S, N, substituted N, or a phosphorus containing group; X comprises H, a removable protecting group, a siNA molecule or a portion thereof; W comprises a linker molecule or chemical linkage that can be present or absent; SG comprises a sugar, for example galactose, galactosamine,

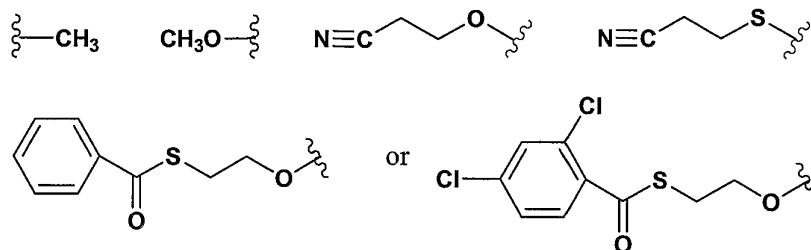
N-acetyl-galactosamine, glucose, mannose, fructose, or fucose and the respective D or L, alpha or beta isomers, and each n is independently an integer from about 0 to about 20. In another embodiment, W is selected from the group consisting of amide, phosphate, phosphate ester, phosphoramidate, or thiophosphate ester linkage.

5 In another embodiment, the invention features a compound having Formula 57:



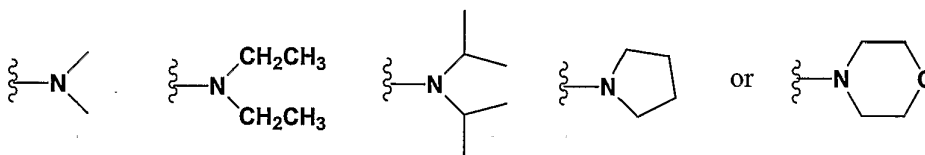
57

wherein R<sub>1</sub> can include the groups:



10

and wherein R<sub>2</sub> can include the groups:

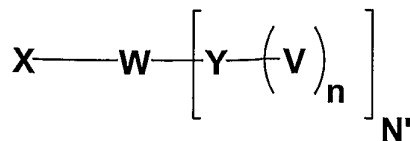


and wherein Tr is a removable protecting group, for example a trityl, monomethoxytrityl, or dimethoxytrityl; SG comprises a sugar, for example galactose, galactosamine, N-acetyl-galactosamine, glucose, mannose, fructose, or fucose and the respective D or L, alpha or beta isomers, and n is an integer from about 1 to about 20.

In one embodiment, compounds having Formula 52, 53, 54, 55, 56, and 57 are featured wherein each nitrogen adjacent to a carbonyl can independently be substituted for

a carbonyl adjacent to a nitrogen or each carbonyl adjacent to a nitrogen can be substituted for a nitrogen adjacent to a carbonyl.

In another embodiment, the invention features a compound having Formula 58:



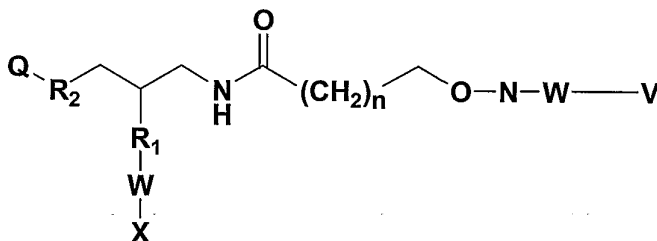
5

58

wherein X comprises a siNA molecule or portion thereof; W comprises a linker molecule or chemical linkage that can be present or absent; Y comprises a linker molecule or amino acid that can be present or absent; V comprises a signal protein or peptide, for example Human serum albumin protein, Antennapedia peptide, Kaposi fibroblast growth factor peptide, Caiman crocodylus Ig(5) light chain peptide, HIV envelope glycoprotein gp41 peptide, HIV-1 Tat peptide, Influenza hemagglutinin envelope glycoprotein peptide, or transportan A peptide; each n is independently an integer from about 1 to about 50; and N' is an integer from about 1 to about 100. In another embodiment, W is selected from the group consisting of amide, phosphate, phosphate ester, phosphoramidate, or thiophosphate ester linkage.

15

In another embodiment, the invention features a compound having Formula 59:

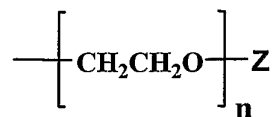


59

wherein each R<sub>1</sub> independently comprises O, S, N, substituted N, or a phosphorus containing group; each R<sub>2</sub> independently comprises O, S, or N; X comprises H, amino, substituted amino, nucleotide, nucleoside, nucleic acid, oligonucleotide, or other biologically active molecule; n is an integer from about 1 to about 50, Q comprises H or a removable protecting group which can be optionally absent, each W independently comprises a linker molecule or chemical linkage that can be present or absent, and V

20

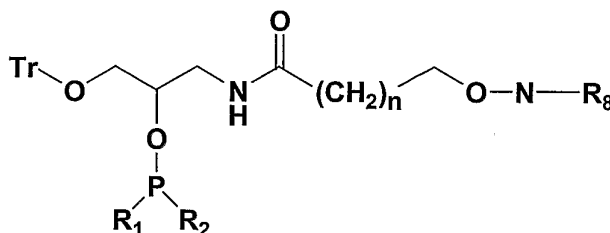
comprises a signal protein or peptide, for example Human serum albumin protein, Antennapedia peptide, Kaposi fibroblast growth factor peptide, Caiman crocodylus Ig(5) light chain peptide, HIV envelope glycoprotein gp41 peptide, HIV-1 Tat peptide, Influenza hemagglutinin envelope glycoprotein peptide, or transportan A peptide, or a compound  
5 having Formula 45



45

wherein Z comprises H, OH, O-alkyl, SH, S-alkyl, alkyl, substituted alkyl, aryl, substituted aryl, amino, substituted amino, a removable protecting group, a siNA molecule  
10 or a portion thereof; and n is an integer from about 1 to about 100. In another embodiment, W is selected from the group consisting of amide, phosphate, phosphate ester, phosphoramidate, or thiophosphate ester linkage.

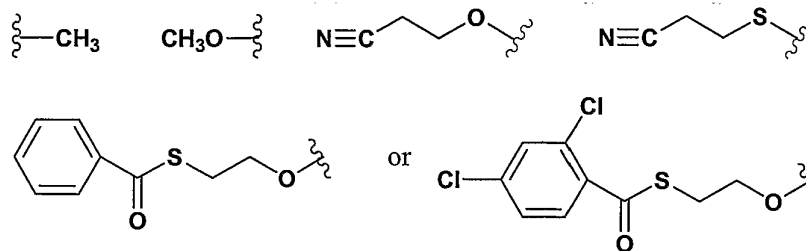
In another embodiment, the invention features a compound having Formula 60:



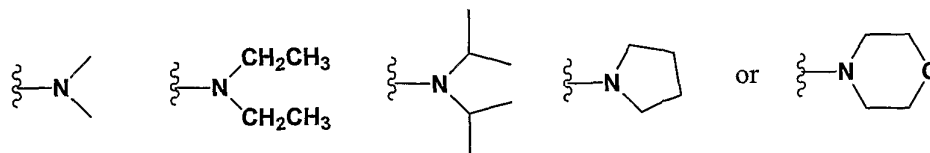
15

60

wherein R<sub>1</sub> can include the groups:

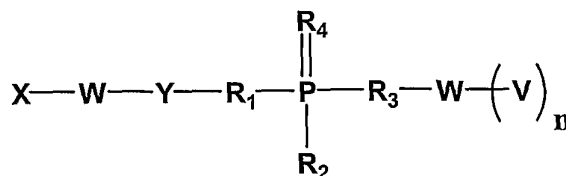


and wherein R<sub>2</sub> can include the groups:



and wherein Tr is a removable protecting group, for example a trityl, monomethoxytrityl, or dimethoxytrityl; n is an integer from about 1 to about 50; and R<sub>8</sub> is a nitrogen protecting group, for example a phthaloyl, trifluoroacetyl, Fmoc, or monomethoxytrityl group.

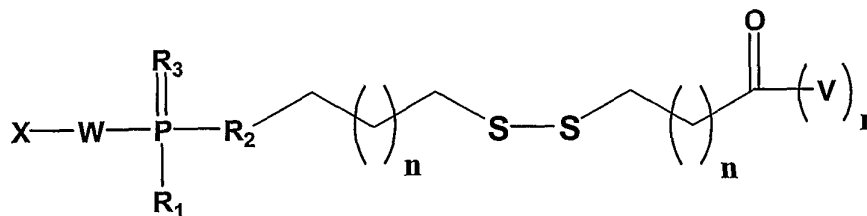
5 In another embodiment, the invention features a compound having Formula 61:



61

wherein X comprises a siNA molecule or portion thereof; each W independently comprises a linker molecule or chemical linkage that can be the same or different and can be present or absent, Y comprises a linker molecule that can be present or absent; each 10 5 independently comprises a signal protein or peptide, for example Human serum albumin protein, Antennapedia peptide, Kaposi fibroblast growth factor peptide, Caiman crocodylus Ig(5) light chain peptide, HIV envelope glycoprotein gp41 peptide, HIV-1 Tat peptide, Influenza hemagglutinin envelope glycoprotein peptide, or transportan A peptide;; 15 each R<sub>1</sub>, R<sub>2</sub>, R<sub>3</sub>, and R<sub>4</sub> independently comprises O, OH, H, alkyl, alkylhalo, O-alkyl, O-alkylcyano, S, S-alkyl, S-alkylcyano, N or substituted N, and n is an integer from about 1 to about 10. In another embodiment, W is selected from the group consisting of amide, phosphate, phosphate ester, phosphoramidate, or thiophosphate ester linkage.

In another embodiment, the invention features a compound having Formula 62:



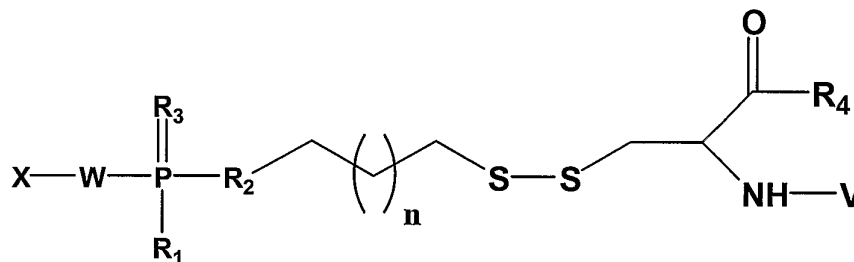
20

62



wherein X comprises a siNA molecule or portion thereof; each 5 independently comprises a signal protein or peptide, for example Human serum albumin protein, Antennapedia peptide, Kaposi fibroblast growth factor peptide, Caiman crocodylus Ig(5) light chain peptide, HIV envelope glycoprotein gp41 peptide, HIV-1 Tat peptide, Influenza hemagglutinin envelope glycoprotein peptide, or transportan A peptide; W comprises a linker molecule or chemical linkage that can be present or absent; each R<sub>1</sub>, R<sub>2</sub>, and R<sub>3</sub> independently comprises O, OH, H, alkyl, alkylhalo, O-alkyl, O-alkylcyano, S, S-alkyl, S-alkylcyano, N or substituted N, and each n is independently an integer from about 1 to about 10. In another embodiment, W is selected from the group consisting of amide, phosphate, phosphate ester, phosphoramidate, or thiophosphate ester linkage.

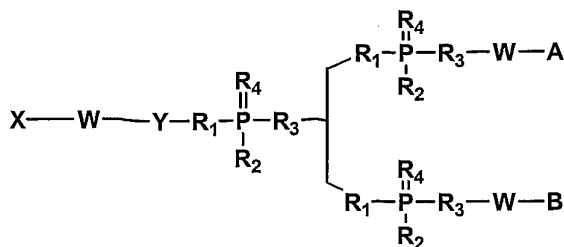
In another embodiment, the invention features a compound having Formula 63:



63

wherein X comprises a siNA molecule or portion thereof; V comprises a signal protein or peptide, for example Human serum albumin protein, Antennapedia peptide, Kaposi fibroblast growth factor peptide, Caiman crocodylus Ig(5) light chain peptide, HIV envelope glycoprotein gp41 peptide, HIV-1 Tat peptide, Influenza hemagglutinin envelope glycoprotein peptide, or transportan A peptide; W comprises a linker molecule or chemical linkage that can be present or absent; each R<sub>1</sub>, R<sub>2</sub>, R<sub>3</sub> independently comprises O, OH, H, alkyl, alkylhalo, O-alkyl, O-alkylcyano, S, S-alkyl, S-alkylcyano, N or substituted N, R<sub>4</sub> represents an ester, amide, or protecting group, and each n is independently an integer from about 1 to about 10. In another embodiment, W is selected from the group consisting of amide, phosphate, phosphate ester, phosphoramidate, or thiophosphate ester linkage.

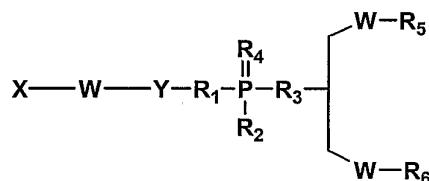
In another embodiment, the invention features a compound having Formula 64:



64

wherein X comprises a siNA molecule or portion thereof; each W independently comprises a linker molecule or chemical linkage that can be present or absent, Y comprises  
 5 a linker molecule that can be present or absent; each R<sub>1</sub>, R<sub>2</sub>, R<sub>3</sub>, and R<sub>4</sub> independently comprises O, OH, H, alkyl, alkylhalo, O-alkyl, O-alkylcyano, S, S-alkyl, S-alkylcyano, N or substituted N, A comprises a nitrogen containing group, and B comprises a lipophilic group. In another embodiment, W is selected from the group consisting of amide, phosphate, phosphate ester, phosphoramidate, or thiophosphate ester linkage.

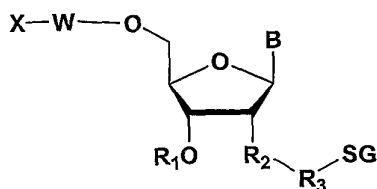
10 In another embodiment, the invention features a compound having Formula 65:



65

wherein X comprises a siNA molecule or portion thereof; each W independently comprises a linker molecule or chemical linkage that can be present or absent, Y comprises  
 15 a linker molecule that can be present or absent; each R<sub>1</sub>, R<sub>2</sub>, R<sub>3</sub>, and R<sub>4</sub> independently comprises O, OH, H, alkyl, alkylhalo, O-alkyl, O-alkylcyano, S, S-alkyl, S-alkylcyano, N or substituted N, RV comprises the lipid or phospholipid component of any of Formulae 47-50, and R<sub>6</sub> comprises a nitrogen containing group. In another embodiment, W is selected from the group consisting of amide, phosphate, phosphate ester, phosphoramidate,  
 20 or thiophosphate ester linkage.

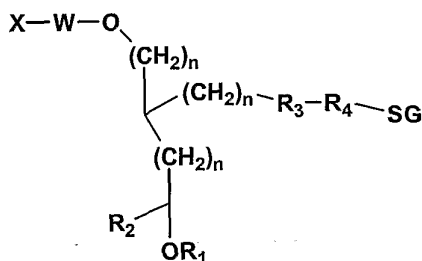
In another embodiment, the invention features a compound having Formula 92:



92

wherein B comprises H, a nucleoside base, or a non-nucleosidic base with or without protecting groups; each R<sub>1</sub> independently comprises O, OH, H, alkyl, alkylhalo, O-alkyl, O-alkylhalo, S, N, substituted N, or a phosphorus containing group; X comprises H, a removable protecting group, amino, substituted amino, nucleotide, nucleoside, nucleic acid, oligonucleotide, enzymatic nucleic acid, amino acid, peptide, protein, lipid, phospholipid, biologically active molecule or label; W comprises a linker molecule or chemical linkage that can be present or absent; R<sub>2</sub> comprises O, NH, S, CO, COO, ON=C, or alkyl; R<sub>3</sub> comprises alkyl, akloxy, or an aminoacyl side chain; and SG comprises a sugar, for example galactose, galactosamine, N-acetyl-galactosamine, glucose, mannose, fructose, or fucose and the respective D or L, alpha or beta isomers. In another embodiment, W is selected from the group consisting of amide, phosphate, phosphate ester, phosphoramidate, or thiophosphate ester linkage.

15 In another embodiment, the invention features a compound having Formula 86:

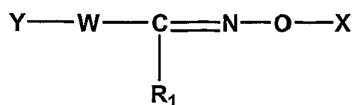


86

wherein R<sub>1</sub> comprises H, alkyl, alkylhalo, N, substituted N, or a phosphorus containing group; R<sub>2</sub> comprises H, O, OH, alkyl, alkylhalo, halo, S, N, substituted N, or a phosphorus containing group; X comprises H, a removable protecting group, a siNA molecule or a portion thereof; W comprises a linker molecule or chemical linkage that can be present or absent; R<sub>3</sub> comprises O, NH, S, CO, COO, ON=C, or alkyl; R<sub>4</sub> comprises alkyl, akloxy, or an aminoacyl side chain; and SG comprises a sugar, for example galactose,

galactosamine, N-acetyl-galactosamine, glucose, mannose, fructose, or fucose and the respective D or L, alpha or beta isomers, and each n is independently an integer from about 0 to about 20. In another embodiment, W is selected from the group consisting of amide, phosphate, phosphate ester, phosphoramidate, or thiophosphate ester linkage.

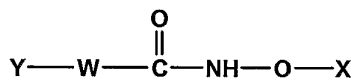
5 In another embodiment, the invention features a compound having Formula 87:



87

wherein X comprises a protein, peptide, antibody, lipid, phospholipid, oligosaccharide, label, biologically active molecule, for example a vitamin such as folate,  
 10 vitamin A, E, B6, B12, coenzyme, antibiotic, antiviral, nucleic acid, nucleotide, nucleoside, or oligonucleotide such as an enzymatic nucleic acid, allozyme, antisense nucleic acid, siNA, 2,5-A chimera, decoy, aptamer or triplex forming oligonucleotide, or polymers such as polyethylene glycol; W comprises a linker molecule or chemical linkage that can be present or absent; and Y comprises siNA or a portion thereof; R<sub>1</sub> comprises H, alkyl, or  
 15 substituted alkyl. In another embodiment, W is selected from the group consisting of amide, phosphate, phosphate ester, phosphoramidate, or thiophosphate ester linkage.

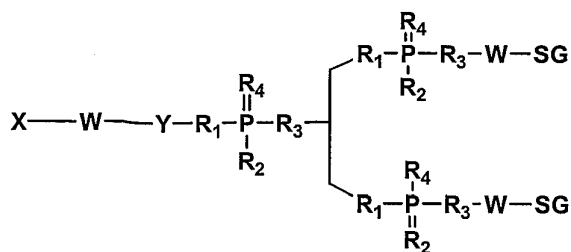
In another embodiment, the invention features a compound having Formula 88:



88

20 wherein X comprises a protein, peptide, antibody, lipid, phospholipid, oligosaccharide, label, biologically active molecule, for example a vitamin such as folate, vitamin A, E, B6, B12, coenzyme, antibiotic, antiviral, nucleic acid, nucleotide, nucleoside, or oligonucleotide such as an enzymatic nucleic acid, allozyme, antisense nucleic acid, siNA, 2,5-A chimera, decoy, aptamer or triplex forming oligonucleotide, or polymers such as polyethylene glycol; W comprises a linker molecule or chemical linkage that can be present or absent, and Y comprises a siNA or a portion thereof. In another embodiment, W is selected from the group consisting of amide, phosphate, phosphate ester, phosphoramidate, or thiophosphate ester linkage.

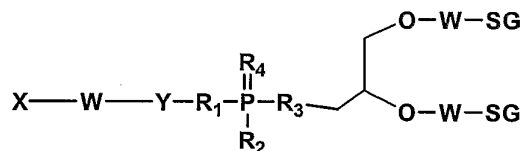
In another embodiment, the invention features a compound having Formula 99:



99

wherein X comprises a siNA molecule or portion thereof; each W independently  
 5 comprises a linker molecule or chemical linkage that can be present or absent, Y comprises  
 a linker molecule that can be present or absent; each R<sub>1</sub>, R<sub>2</sub>, R<sub>3</sub>, and R<sub>4</sub> independently  
 comprises O, OH, H, alkyl, alkylhalo, O-alkyl, O-alkylcyano, S, S-alkyl, S-alkylcyano, N  
 or substituted N, and SG comprises a sugar, for example galactose, galactosamine,  
 N-acetyl-galactosamine or branched derivative thereof, glucose, mannose, fructose, or  
 10 fucose and the respective D or L, alpha or beta isomers. In another embodiment, W is  
 selected from the group consisting of amide, phosphate, phosphate ester, phosphoramidate,  
 or thiophosphate ester linkage.

In another embodiment, the invention features a compound having Formula 100:

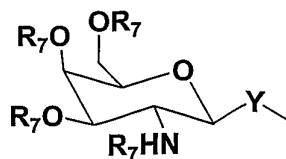


15

100

wherein X comprises a siNA molecule or portion thereof; W comprises a linker  
 molecule or chemical linkage that can be present or absent, Y comprises a linker molecule  
 that can be present or absent; each R<sub>1</sub>, R<sub>2</sub>, R<sub>3</sub>, and R<sub>4</sub> independently comprises O, OH, H,  
 alkyl, alkylhalo, O-alkyl, O-alkylcyano, S, S-alkyl, S-alkylcyano, N or substituted N, and  
 20 SG comprises a sugar, for example galactose, galactosamine, N-acetyl-galactosamine or  
 branched derivative thereof, glucose, mannose, fructose, or fucose and the respective D or  
 L, alpha or beta isomers. In another embodiment, W is selected from the group consisting  
 of amide, phosphate, phosphate ester, phosphoramidate, or thiophosphate ester linkage.

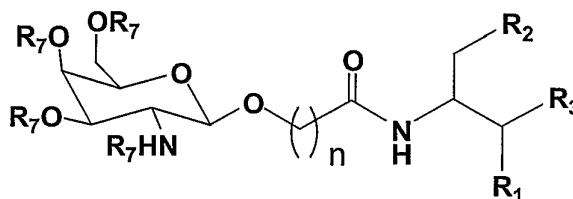
In one embodiment, the SG component of any compound having Formulae 99 or 100 comprises a compound having Formula 101:



101

- 5            wherein Y comprises a linker molecule or chemical linkage that can be present or absent and each R<sub>7</sub> independently comprises an acyl group that can be present or absent, for example a acetyl group.

In one embodiment, the W-SG component of a compound having Formulae 99 comprises a compound having Formula 102:

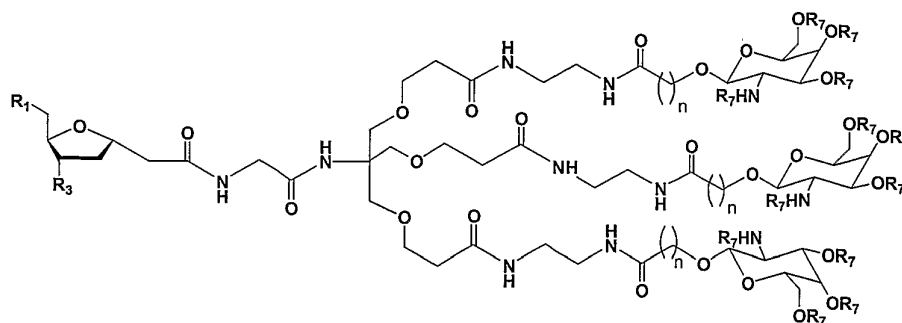


10

102

- 15            wherein R<sub>2</sub> comprises O, OH, H, alkyl, alkylhalo, O-alkyl, O-alkylhalo, S, N, substituted N, a protecting group, or another compound having Formula 102; R<sub>1</sub> independently H, OH, alkyl, substituted alkyl, or halo and each R<sub>7</sub> independently comprises an acyl group that can be present or absent, for example a acetyl group, and R<sub>3</sub> comprises O or R<sub>3</sub> in Formula 99, and n is an integer from about 1 to about 20.

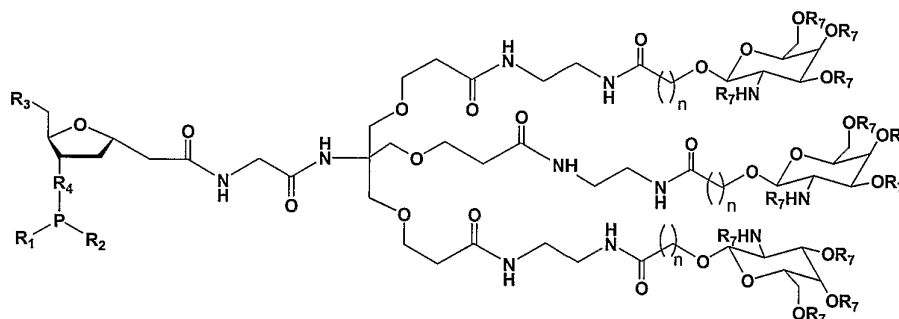
In one embodiment, the W-SG component of a compound having Formulae 99 comprises a compound having Formula 103:



103

wherein  $R_1$  comprises H, alkyl, alkylhalo, O-alkyl, O-alkylhalo, S, N, substituted N, a protecting group, or another compound having Formula 103; each  $R_7$  independently comprises an acyl group that can be present or absent, for example a acetyl group, and  $R_3$  comprises H or  $R_3$  in Formula 99, and each  $n$  is independently an integer from about 1 to about 20.

In one embodiment, the invention features a compound having Formula 104:

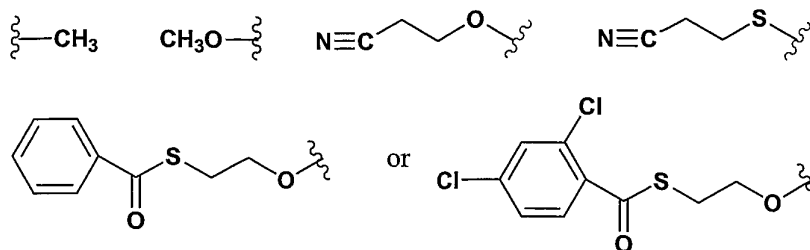


10

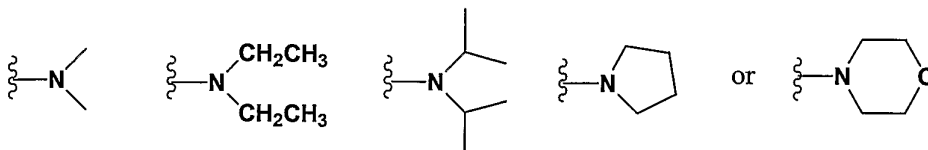
104

wherein  $R_3$  comprises H, OH, amino, substituted amino, nucleotide, nucleoside, nucleic acid, oligonucleotide, amino acid, peptide, protein, lipid, phospholipid, label, or a portion thereof, or  $OR_5$  where  $R_5$  a removable protecting group,  $R_4$  comprises O, alkyl, alkylhalo, O-alkyl, O-alkylcyano, S, S-alkyl, S-alkylcyano, N or substituted N, each  $R_7$  independently comprises an acyl group that can be present or absent, for example a acetyl group, and each  $n$  is independently an integer from about 1 to about 20, and

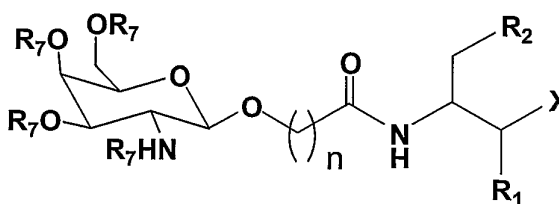
wherein  $R_1$  can include the groups:



and wherein R<sub>2</sub> can include the groups:



In one embodiment, the invention features a compound having Formula 105:



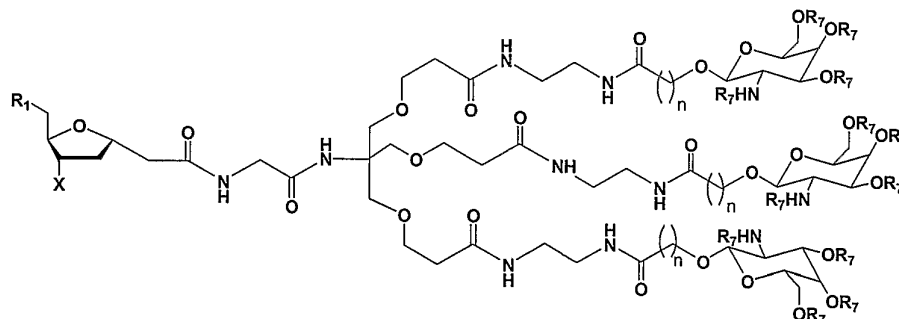
5

105

wherein X comprises a siNA molecule or a portion thereof, R<sub>2</sub> comprises O, OH, H, alkyl, alkylhalo, O-alkyl, O-alkylhalo, S, N, substituted N, a protecting group, or a nucleotide, polynucleotide, or oligonucleotide or a portion thereof; R<sub>1</sub> independently H, OH, alkyl, substituted alkyl, or halo and each R<sub>7</sub> independently comprises an acyl group that can be present or absent, for example a acetyl group, and n is an integer from about 1 to about 20.

10

In one embodiment, the invention features a compound having Formula 106:



15

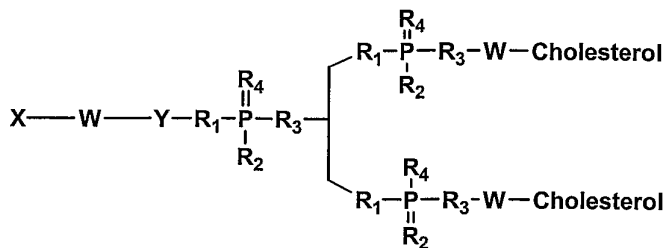
106

193



wherein X comprises a siNA molecule or a portion thereof, R<sub>1</sub> comprises H, OH, amino, substituted amino, nucleotide, nucleoside, nucleic acid, oligonucleotide, amino acid, peptide, protein, lipid, phospholipid, label, or a portion thereof, or OR<sub>5</sub> where R<sub>5</sub> a removable protecting group, each R<sub>7</sub> independently comprises an acyl group that can be present or absent, for example a acetyl group, and each n is independently an integer from about 1 to about 20

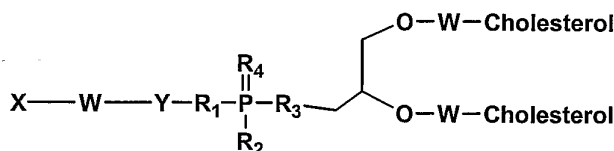
In another embodiment, the invention features a compound having Formula 107:



107

wherein X comprises a siNA molecule or portion thereof; each W independently comprises a linker molecule or chemical linkage that can be present or absent, Y comprises a linker molecule that can be present or absent; each R<sub>1</sub>, R<sub>2</sub>, R<sub>3</sub>, and R<sub>4</sub> independently comprises O, OH, H, alkyl, alkylhalo, O-alkyl, O-alkylcyano, S, S-alkyl, S-alkylcyano, N or substituted N, and Cholesterol comprises cholesterol or an analog, derivative, or metabolite thereof. In another embodiment, W is selected from the group consisting of amide, phosphate, phosphate ester, phosphoramidate, or thiophosphate ester linkage.

In another embodiment, the invention features a compound having Formula 108:

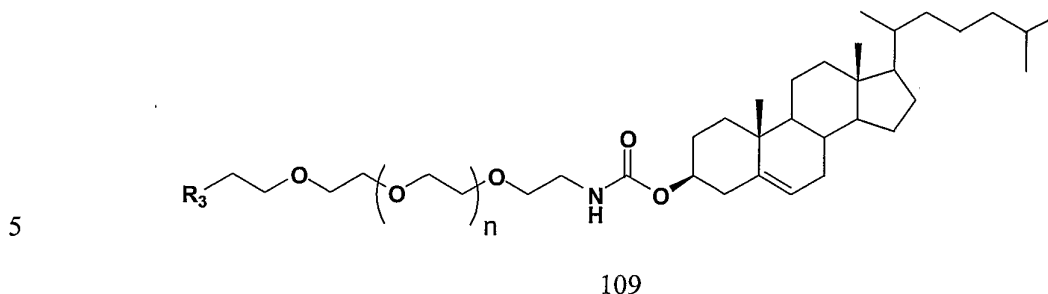


108

wherein X comprises a siNA molecule or portion thereof; W comprises a linker molecule or chemical linkage that can be present or absent, Y comprises a linker molecule that can be present or absent; each R<sub>1</sub>, R<sub>2</sub>, R<sub>3</sub>, and R<sub>4</sub> independently comprises O, OH, H, alkyl, alkylhalo, O-alkyl, O-alkylcyano, S, S-alkyl, S-alkylcyano, N or substituted N, and Cholesterol comprises cholesterol or an analog, derivative, or metabolite thereof. In

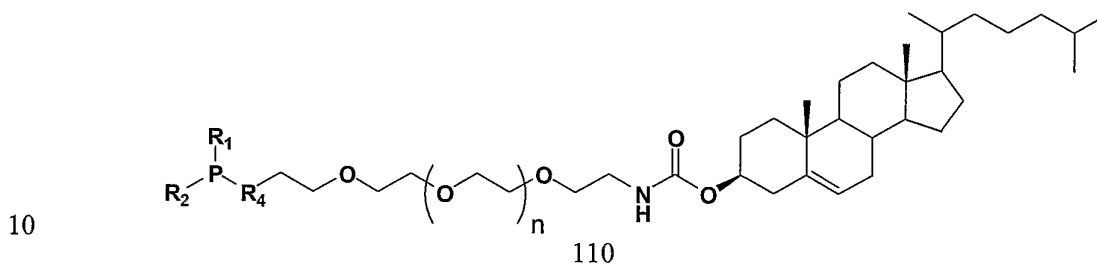
another embodiment, W is selected from the group consisting of amide, phosphate, phosphate ester, phosphoramidate, or thiophosphate ester linkage.

In one embodiment, the W-Cholesterol component of a compound having Formula 107 comprises a compound having Formula 109:



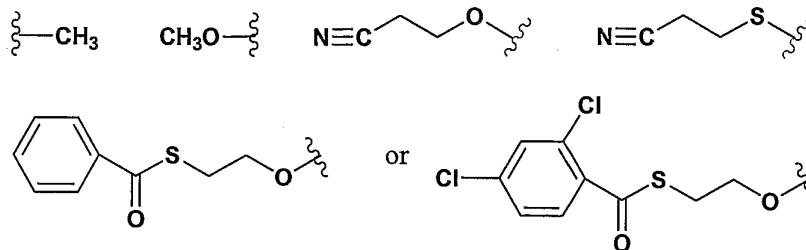
wherein R<sub>3</sub> comprises R<sub>3</sub> as described in Formula 107, and n is independently an integer from about 1 to about 20.

In one embodiment, the invention features a compound having Formula 110:

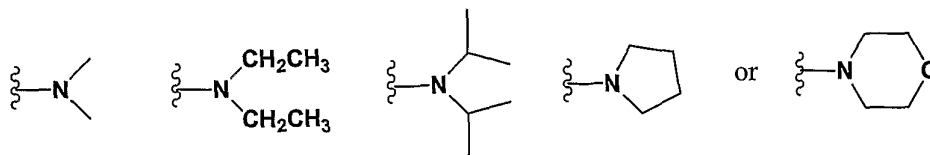


wherein R<sub>4</sub> comprises O, alkyl, alkylhalo, O-alkyl, O-alkylcyano, S, S-alkyl, S-alkylcyano, N or substituted N, each n is independently an integer from about 1 to about 20, and

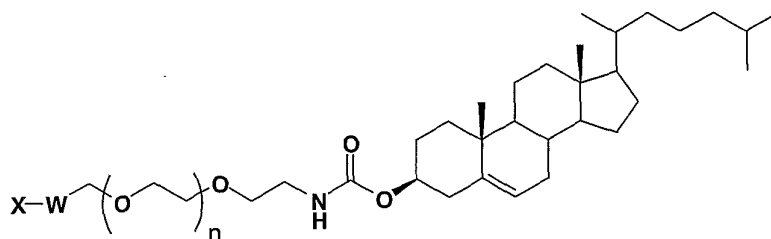
15 wherein R<sub>1</sub> can include the groups:



and wherein R<sub>2</sub> can include the groups:



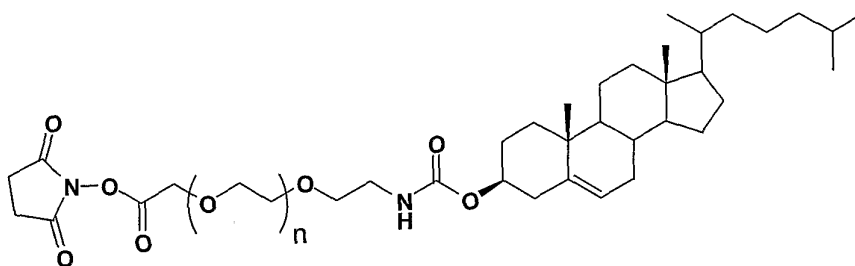
In one embodiment, the invention features a compound having Formula 111:



111

- 5            wherein X comprises a siNA molecule or portion thereof; W comprises a linker molecule or chemical linkage that can be present or absent, and n is an integer from about 1 to about 20. In another embodiment, W is selected from the group consisting of amide, phosphate, phosphate ester, phosphoramidate, or thiophosphate ester linkage.

In one embodiment, the invention features a compound having Formula 112:

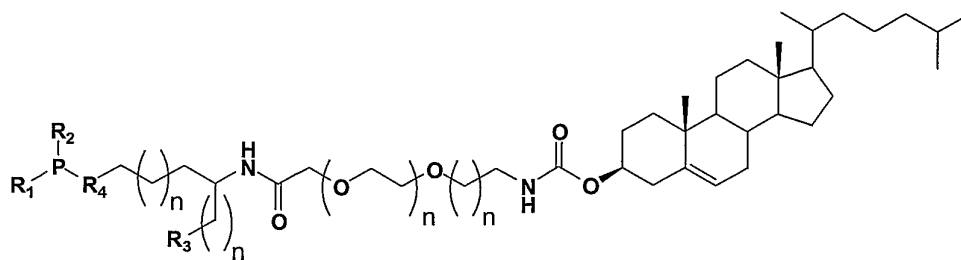


10

112

- 15            wherein n is an integer from about 1 to about 20. In another embodiment, a compound having Formula 112 is used to generate a compound having Formula 111 via NHS ester mediated coupling with a biologically active molecule, such as a siNA molecule or a portion thereof. In a non-limiting example, the NHS ester coupling can be effectuated via attachment to a free amine present in the siNA molecule, such as an amino linker molecule present on a nucleic acid sugar (e.g., 2'-amino linker) or base (e.g., C5 alkyl amine linker) component of the siNA molecule.

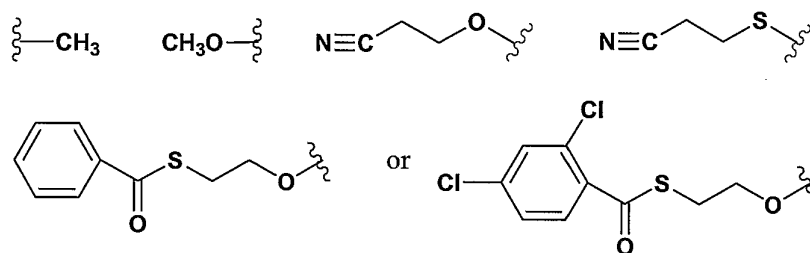
In one embodiment, the invention features a compound having Formula 113:



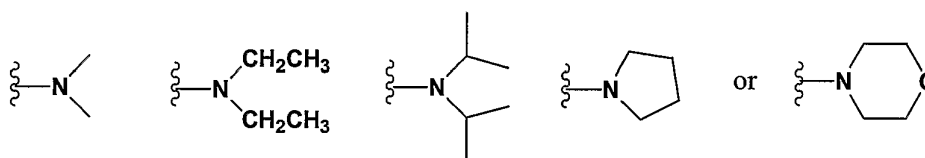
113

wherein R<sub>3</sub> comprises H, OH, amino, substituted amino, nucleotide, nucleoside, nucleic acid, oligonucleotide, amino acid, peptide, protein, lipid, phospholipid, label, or a portion thereof, or OR<sub>5</sub> where R<sub>5</sub> a removable protecting group, R<sub>4</sub> comprises O, alkyl, alkylhalo, O-alkyl, O-alkylcyano, S, S-alkyl, S-alkylcyano, N or substituted N, each n is independently an integer from about 1 to about 20, and

wherein R<sub>1</sub> can include the groups:

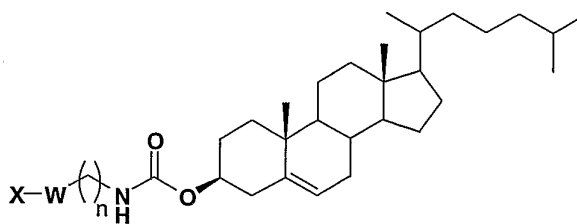


and wherein R<sub>2</sub> can include the groups:



In another embodiment, a compound having Formula 113 is used to generate a compound having Formula 111 via phosphoramidite mediated coupling with a biologically active molecule, such as a siNA molecule or a portion thereof.

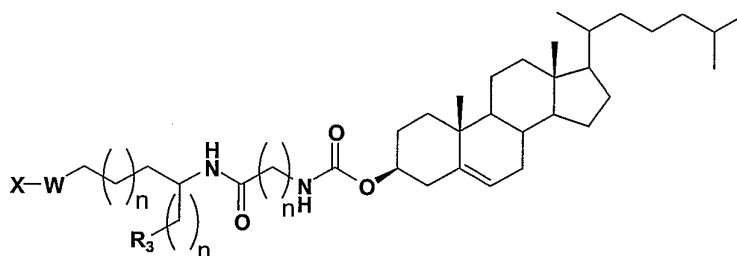
In one embodiment, the invention features a compound having Formula 114:



114

wherein X comprises a siNA molecule or portion thereof; W comprises a linker molecule or chemical linkage that can be present or absent, and n is an integer from about 1 to about 20. In another embodiment, W is selected from the group consisting of amide, phosphate, phosphate ester, phosphoramidate, or thiophosphate ester linkage.

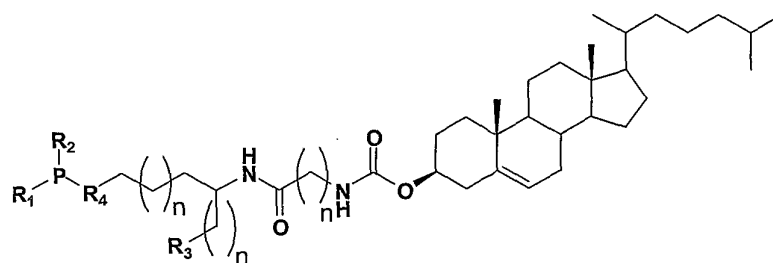
In one embodiment, the invention features a compound having Formula 115:



115

wherein X comprises a siNA molecule or portion thereof; W comprises a linker molecule or chemical linkage that can be present or absent,  $R_3$  comprises H, OH, amino, substituted amino, nucleotide, nucleoside, nucleic acid, oligonucleotide, amino acid, peptide, protein, lipid, phospholipid, label, or a portion thereof, or  $OR_5$  where  $R_5$  a removable protecting group, and each n is independently an integer from about 1 to about 20. In another embodiment, W is selected from the group consisting of amide, phosphate, phosphate ester, phosphoramidate, or thiophosphate ester linkage.

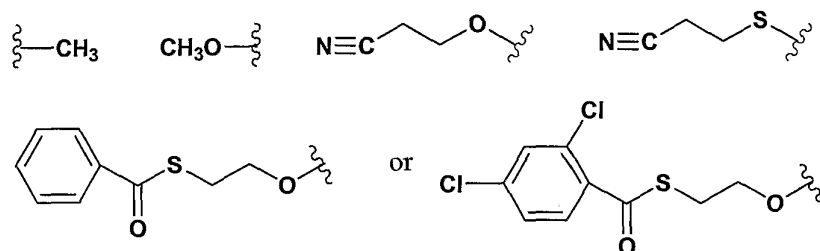
In one embodiment, the invention features a compound having Formula 116:



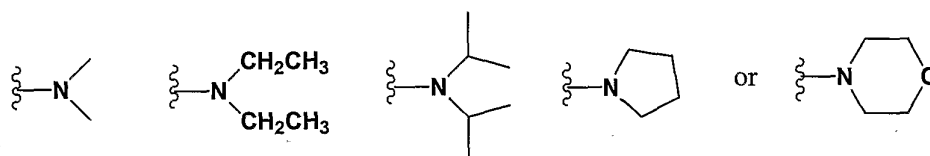
116

wherein  $R_3$  comprises H, OH, amino, substituted amino, nucleotide, nucleoside, nucleic acid, oligonucleotide, amino acid, peptide, protein, lipid, phospholipid, label, or a portion thereof, or  $OR_5$  where  $R_5$  a removable protecting group,  $R_4$  comprises O, alkyl, alkylhalo, O-alkyl, O-alkylcyano, S, S-alkyl, S-alkylcyano, N or substituted N, each  $n$  is independently an integer from about 1 to about 20, and

wherein  $R_1$  can include the groups:

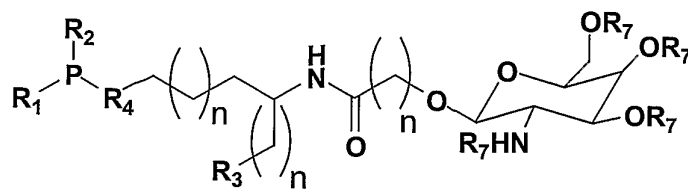


10 and wherein  $R_2$  can include the groups:



In another embodiment, a compound having Formula 116 is used to generate a compound having Formula 114 or 115 via phosphoramidite mediated coupling with a biologically active molecule, such as a siNA molecule or a portion thereof.

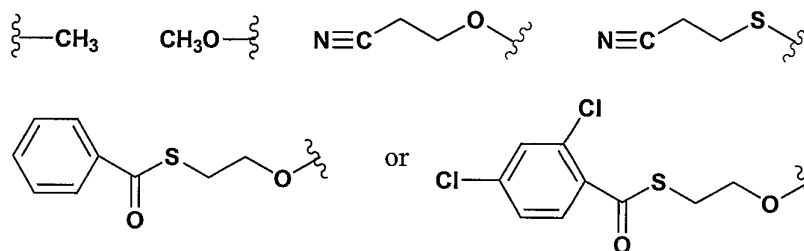
In one embodiment, the invention features a compound having Formula 117:



117

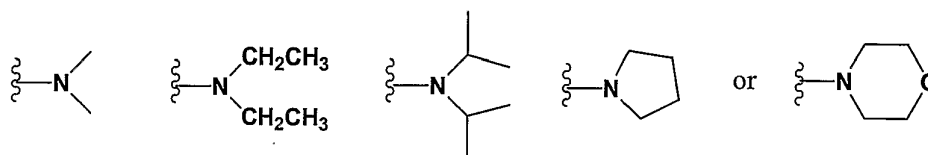
wherein R<sub>3</sub> comprises H, OH, amino, substituted amino, nucleotide, nucleoside, nucleic acid, oligonucleotide, amino acid, peptide, protein, lipid, phospholipid, label, or a portion thereof, or OR<sub>5</sub> where R<sub>5</sub> a removable protecting group, R<sub>4</sub> comprises O, alkyl, alkylhalo, O-alkyl, O-alkylcyano, S, S-alkyl, S-alkylcyano, N or substituted N, each R<sub>7</sub> independently comprises an acyl group that can be present or absent, for example a acetyl group, each n is independently an integer from about 1 to about 20, and

wherein R<sub>1</sub> can include the groups:



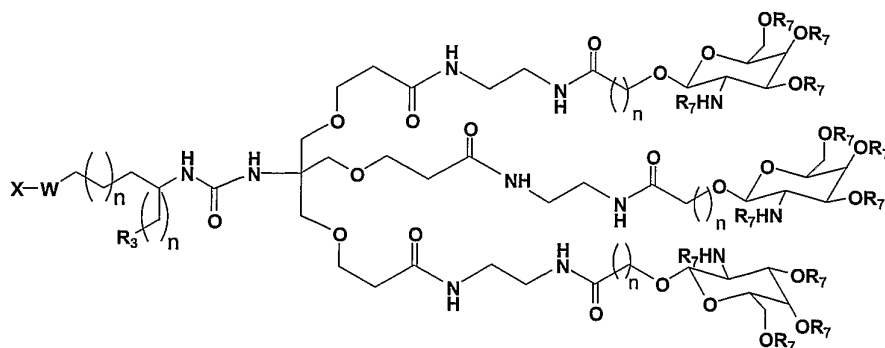
10

and wherein R<sub>2</sub> can include the groups:



In another embodiment, a compound having Formula 117 is used to generate a compound having Formula 105 via phosphoramidite mediated coupling with a biologically active molecule, such as a siNA molecule or a portion thereof.

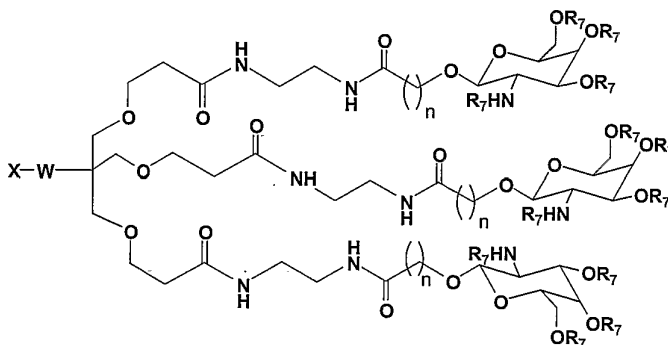
In one embodiment, the invention features a compound having Formula 118:



118

wherein X comprises a siNA molecule or portion thereof; W comprises a linker molecule or chemical linkage that can be present or absent, R<sub>3</sub> comprises H, OH, amino, substituted amino, nucleotide, nucleoside, nucleic acid, oligonucleotide, amino acid, peptide, protein, lipid, phospholipid, label, or a portion thereof, or OR<sub>5</sub> where R<sub>5</sub> a removable protecting group, each R<sub>7</sub> independently comprises an acyl group that can be present or absent, for example a acetyl group, and each n is independently an integer from about 1 to about 20. In another embodiment, W is selected from the group consisting of amide, phosphate, phosphate ester, phosphoramidate, or thiophosphate ester linkage.

In one embodiment, the invention features a compound having Formula 119:



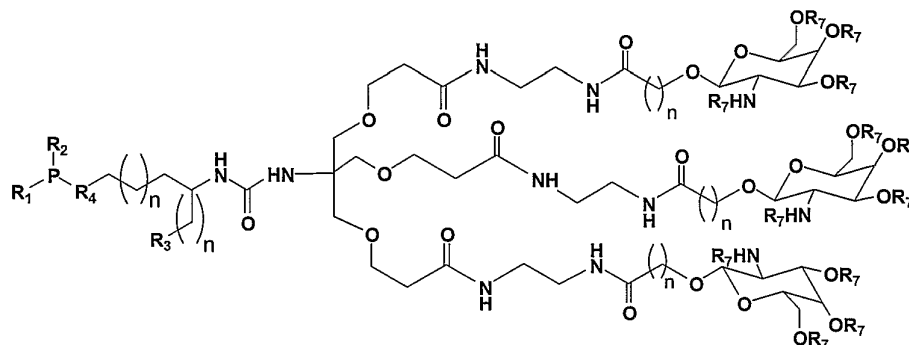
119

wherein X comprises a siNA molecule or portion thereof; W comprises a linker molecule or chemical linkage that can be present or absent, each R<sub>7</sub> independently comprises an acyl group that can be present or absent, for example a acetyl group, and each n is independently an integer from about 1 to about 20. In another embodiment, W is



selected from the group consisting of amide, phosphate, phosphate ester, phosphoramidate, or thiophosphate ester linkage.

In one embodiment, the invention features a compound having Formula 120:

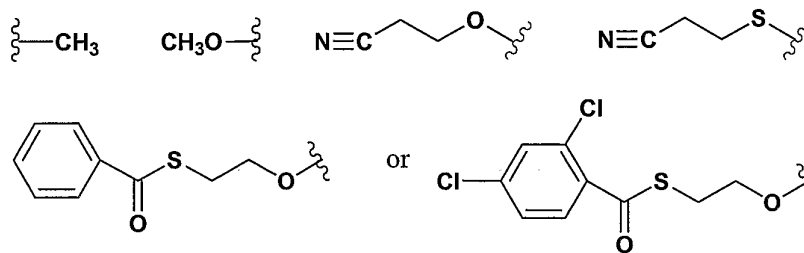


5

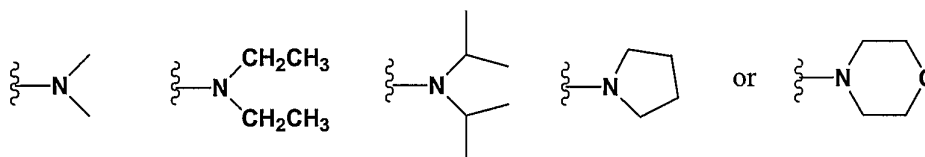
120

wherein R<sub>3</sub> comprises H, OH, amino, substituted amino, nucleotide, nucleoside, nucleic acid, oligonucleotide, amino acid, peptide, protein, lipid, phospholipid, label, or a portion thereof, or OR<sub>5</sub> where R<sub>5</sub> a removable protecting group, R<sub>4</sub> comprises O, alkyl, alkylhalo, O-alkyl, O-alkylcyano, S, S-alkyl, S-alkylcyano, N or substituted N, each R<sub>7</sub> independently comprises an acyl group that can be present or absent, for example a acetyl group, each n is independently an integer from about 1 to about 20, and

wherein R<sub>1</sub> can include the groups:



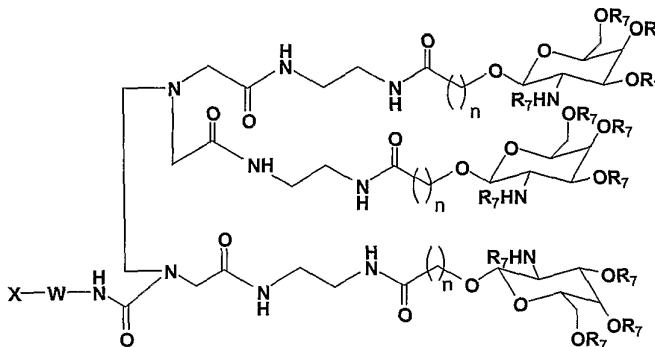
and wherein R<sub>2</sub> can include the groups:



15

In another embodiment, a compound having Formula 120 is used to generate a compound having Formula 118 or 119 via phosphoramidite mediated coupling with a biologically active molecule, such as a siNA molecule or a portion thereof.

In one embodiment, the invention features a compound having Formula 121:



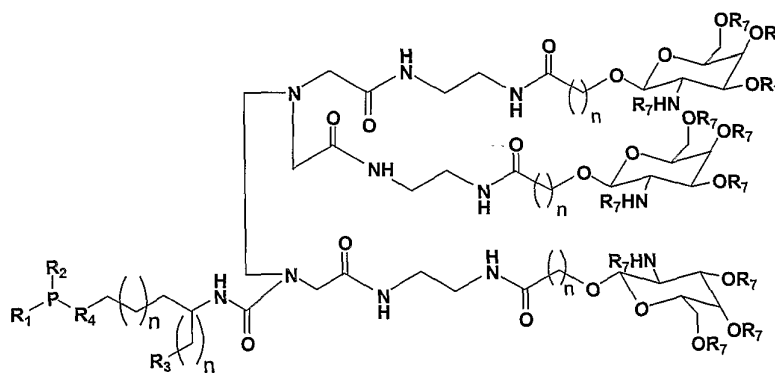
5

121

wherein X comprises a siNA molecule or portion thereof; W comprises a linker molecule or chemical linkage that can be present or absent, each R<sub>7</sub> independently comprises an acyl group that can be present or absent, for example a acetyl group, and each n is independently an integer from about 1 to about 20. In another embodiment, W is selected from the group consisting of amide, phosphate, phosphate ester, phosphoramidate, or thiophosphate ester linkage.

10

In one embodiment, the invention features a compound having Formula 122:



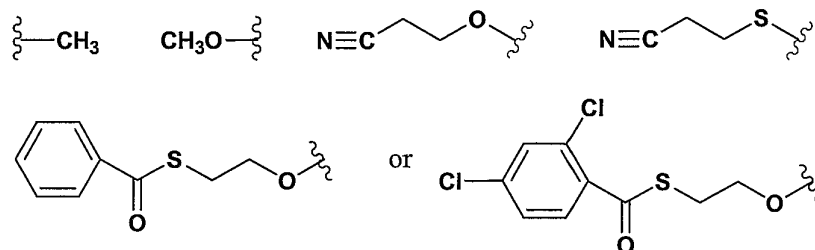
15

122

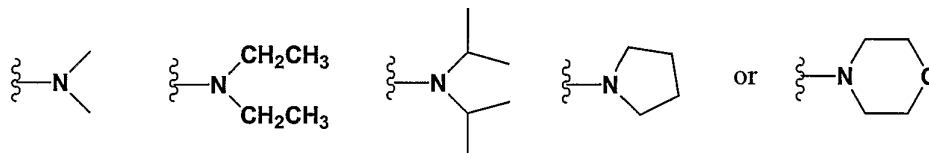
wherein R<sub>3</sub> comprises H, OH, amino, substituted amino, nucleotide, nucleoside, nucleic acid, oligonucleotide, amino acid, peptide, protein, lipid, phospholipid, label, or a

portion thereof, or OR<sub>5</sub> where R<sub>5</sub> a removable protecting group, R<sub>4</sub> comprises O, alkyl, alkylhalo, O-alkyl, O-alkylcyano, S, S-alkyl, S-alkylcyano, N or substituted N, each R<sub>7</sub> independently comprises an acyl group that can be present or absent, for example a acetyl group, each n is independently an integer from about 1 to about 20, and

5 wherein R<sub>1</sub> can include the groups:

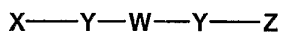


and wherein R<sub>2</sub> can include the groups:



10 In another embodiment, a compound having Formula 122 is used to generate a compound having Formula 121 via phosphoramidite mediated coupling with a biologically active molecule, such as a siNA molecule or a portion thereof.

In one embodiment, the invention features a compound having Formula 94,



94

15 wherein X comprises a siNA molecule or a portion thereof; each Y independently comprises a linker or chemical linkage that can be present or absent, W comprises a biodegradable nucleic acid linker molecule, and Z comprises a biologically active molecule, for example an enzymatic nucleic acid, allozyme, antisense nucleic acid, siNA, 2,5-A chimera, decoy, aptamer or triplex forming oligonucleotide, peptide, protein, or antibody.

20 In another embodiment, W of a compound having Formula 94 of the invention comprises 5'-cytidine-deoxythymidine-3', 5'-deoxythymidine-cytidine-3',

5'-cytidine-deoxyuridine-3', 5'-deoxyuridine-cytidine-3', 5'-uridine-deoxythymidine-3', or 5'-deoxythymidine-uridine-3'.

In yet another embodiment, W of a compound having Formula 94 of the invention comprises 5'-adenosine-deoxythymidine-3', 5'-deoxythymidine-adenosine-3', 5'-adenosine-deoxyuridine-3', or 5'-deoxyuridine-adenosine-3'.

In another embodiment, Y of a compound having Formula 94 of the invention comprises a phosphorus containing linkage, phosphoramidate linkage, phosphodiester linkage, phosphorothioate linkage, amide linkage, ester linkage, carbamate linkage, disulfide linkage, oxime linkage, or morpholino linkage.

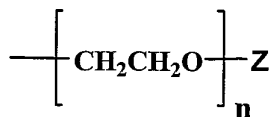
10 In another embodiment, compounds having Formula 89 and 91 of the invention are synthesized by periodate oxidation of an N-terminal Serine or Threonine residue of a peptide or protein.

In one embodiment, X of compounds having Formulae 43, 44, 46-52, 58, 61-65, 85-88, 92, 94, 95, 99, 100, 105-108, 111, 114, 115, 118, 119, or 121 of the invention comprises a siNA molecule or a portion thereof. In one embodiment, the siNA molecule can be conjugated at the 5' end, 3'-end, or both 5' and 3' ends of the sense strand or region of the siNA. In one embodiment, the siNA molecule can be conjugated at the 3'-end of the antisense strand or region of the siNA with a compound of the invention. In one embodiment, both the sense strand and antisense strands or regions of the siNA molecule are conjugated with a compound of the invention. In one embodiment, only the sense strand or region of the siNA is conjugated with a compound of the invention. In one embodiment, only the antisense strand or region of the siNA is conjugated with a compound of the invention.

25 In one embodiment, W and/or Y of compounds having Formulae 43, 44, 46-52, 58, 61-65, 85-88, 92, 94, 95, 99, 100, 101, 107, 108, 111, 114, 115, 118, 119, or 121 of the invention comprises a degradable or cleavable linker, for example a nucleic acid sequence comprising ribonucleotides and/or deoxynucleotides, such as a dimer, trimer, or tetramer. A non limiting example of a nucleic acid cleavable linker is an adenosine-deoxythymidine (A-dT) dimer or a cytidine-deoxythymidine (C-dT) dimer. In yet another embodiment, W and/or V of compounds having Formulae 43, 44, 48-51, 58, 63-65, 96, 99, 100, 107, 108, 30 111, 114, 115, 118, 119, or 121 of the invention comprises a N-hydroxy succinimide

(NHS) ester linkage, oxime linkage, disulfide linkage, phosphoramidate, phosphorothioate, phosphorodithioate, phosphodiester linkage, or NHC(O), CH<sub>3</sub>NC(O), CONH, C(O)NCH<sub>3</sub>, S, SO, SO<sub>2</sub>, O, NH, NCH<sub>3</sub> group. In another embodiment, the degradable linker, W and/or Y, of compounds having Formulae 43, 44, 46-52, 58, 61-65, 85-88, 92, 94, 95, 99, 100, 101, 107, 108, 111, 114, 115, 118, 119, or 121 of the invention comprises a linker that is susceptible to cleavage by carboxypeptidase activity.

In another embodiment, W and/or Y of Formulae 43, 44, 46-52, 58, 61-65, 85-88, 92, 94, 95, 99, 100, 101, 107, 108, 111, 114, 115, 118, 119, or 121 comprises a polyethylene glycol linker having Formula 45:



10

45

wherein Z comprises H, OH, O-alkyl, SH, S-alkyl, alkyl, substituted alkyl, aryl, substituted aryl, amino, substituted amino, nucleotide, nucleoside, nucleic acid, oligonucleotide, amino acid, peptide, protein, lipid, phospholipid, or label; and n is an integer from about 1 to about 100.

In one embodiment, the nucleic acid conjugates of the instant invention are assembled by solid phase synthesis, for example on an automated peptide synthesizer, for example a Miligen 9050 synthesizer and/or an automated oligonucleotide synthesizer such as an ABI 394, 390Z, or Pharmacia OligoProcess, OligoPilot, OligoMax, or AKTA synthesizer. In another embodiment, the nucleic acid conjugates of the invention are assembled post synthetically, for example, following solid phase oligonucleotide synthesis (see for example **Figures 45, 50, 53, and 73**).

In another embodiment, V of compounds having Formula 58-63 and 96 comprise peptides having SEQ ID NOS: **1114-1123 (Table V)**.

In one embodiment, the nucleic acid conjugates of the instant invention are assembled post synthetically, for example, following solid phase oligonucleotide synthesis.

The present invention provides compositions and conjugates comprising nucleosidic and non-nucleosidic derivatives. The present invention also provides nucleic acid,

polynucleotide and oligonucleotide derivatives including RNA, DNA, and PNA based conjugates. The attachment of compounds of the invention to nucleosides, nucleotides, non-nucleosides, and nucleic acid molecules is provided at any position within the molecule, for example, at internucleotide linkages, nucleosidic sugar hydroxyl groups such as 5', 3', and 2'-hydroxyls, and/or at nucleobase positions such as amino and carbonyl groups.

The exemplary conjugates of the invention are described as compounds of the formulae herein, however, other peptide, protein, phospholipid, and poly-alkyl glycol derivatives are provided by the invention, including various analogs of the compounds of formulae 1-122, including but not limited to different isomers of the compounds described herein.

The exemplary folate conjugates of the invention are described as compounds shown by formulae herein, however, other folate and antifolate derivatives are provided by the invention, including various folate analogs of the formulae of the invention, including dihydrofolates, tetrahydrofolates, tetrahydropterins, folinic acid, pteropolyglutamic acid, 1-deaza, 3-deaza, 5-deaza, 8-deaza, 10-deaza, 1,5-deaza, 5,10 dideaza, 8,10-dideaza, and 5,8-dideaza folates, antifolates, and pteronic acids. As used herein, the term "folate" is meant to refer to folate and folate derivatives, including pteronic acid derivatives and analogs.

The present invention features compositions and conjugates to facilitate delivery of molecules into a biological system such as cells. The conjugates provided by the instant invention can impart therapeutic activity by transferring therapeutic compounds across cellular membranes. The present invention encompasses the design and synthesis of novel agents for the delivery of molecules, including but not limited to siNA molecules. In general, the transporters described are designed to be used either individually or as part of a multi-component system. The compounds of the invention generally shown in Formulae herein are expected to improve delivery of molecules into a number of cell types originating from different tissues, in the presence or absence of serum.

In another embodiment, the compounds of the invention are provided as a surface component of a lipid aggregate, such as a liposome encapsulated with the predetermined molecule to be delivered. Liposomes, which can be unilamellar or multilamellar, can

introduce encapsulated material into a cell by different mechanisms. For example, the liposome can directly introduce its encapsulated material into the cell cytoplasm by fusing with the cell membrane. Alternatively, the liposome can be compartmentalized into an acidic vacuole (i.e., an endosome) and its contents released from the liposome and out of  
5 the acidic vacuole into the cellular cytoplasm.

In one embodiment the invention features a lipid aggregate formulation of the compounds described herein, including phosphatidylcholine (of varying chain length; e.g., egg yolk phosphatidylcholine), cholesterol, a cationic lipid, and 1,2-distearoyl-sn-glycero-3-phosphoethanolamine-polythyleneglycol-2000  
10 (DSPE-PEG2000). The cationic lipid component of this lipid aggregate can be any cationic lipid known in the art such as dioleoyl 1,2,-diacyl-3-trimethylammonium-propane (DOTAP). In another embodiment this cationic lipid aggregate comprises a covalently bound compound described in any of the Formulae herein.

In another embodiment, polyethylene glycol (PEG) is covalently attached to the  
15 compounds of the present invention. The attached PEG can be any molecular weight but is preferably between 2000-50,000 daltons.

The compounds and methods of the present invention are useful for introducing nucleotides, nucleosides, nucleic acid molecules, lipids, peptides, proteins, and/or non-nucleosidic small molecules into a cell. For example, the invention can be used for  
20 nucleotide, nucleoside, nucleic acid, lipids, peptides, proteins, and/or non-nucleosidic small molecule delivery where the corresponding target site of action exists intracellularly.

In one embodiment, the compounds of the instant invention provide conjugates of molecules that can interact with cellular receptors, such as high affinity folate receptors and ASGPr receptors, and provide a number of features that allow the efficient delivery and  
25 subsequent release of conjugated compounds across biological membranes. The compounds utilize chemical linkages between the receptor ligand and the compound to be delivered of length that can interact preferentially with cellular receptors. Furthermore, the chemical linkages between the ligand and the compound to be delivered can be designed as degradable linkages, for example by utilizing a phosphate linkage that is proximal to a  
30 nucleophile, such as a hydroxyl group. Deprotonation of the hydroxyl group or an equivalent group, as a result of pH or interaction with a nuclease, can result in nucleophilic

attack of the phosphate resulting in a cyclic phosphate intermediate that can be hydrolyzed. This cleavage mechanism is analogous RNA cleavage in the presence of a base or RNA nuclease. Alternately, other degradable linkages can be selected that respond to various factors such as UV irradiation, cellular nucleases, pH, temperature etc. The use of  
5 degradable linkages allows the delivered compound to be released in a predetermined system, for example in the cytoplasm of a cell, or in a particular cellular organelle.

The present invention also provides ligand derived phosphoramidites that are readily conjugated to compounds and molecules of interest. Phosphoramidite compounds of the invention permit the direct attachment of conjugates to molecules of interest without the  
10 need for using nucleic acid phosphoramidite species as scaffolds. As such, the used of phosphoramidite chemistry can be used directly in coupling the compounds of the invention to a compound of interest, without the need for other condensation reactions, such as condensation of the ligand to an amino group on the nucleic acid, for example at the N6 position of adenosine or a 2'-deoxy-2'-amino function. Additionally, compounds of the  
15 invention can be used to introduce non-nucleic acid based conjugated linkages into oligonucleotides that can provide more efficient coupling during oligonucleotide synthesis than the use of nucleic acid-based phosphoramidites. This improved coupling can take into account improved steric considerations of abasic or non-nucleosidic scaffolds bearing pendant alkyl linkages.

20 Compounds of the invention utilizing triphosphate groups can be utilized in the enzymatic incorporation of conjugate molecules into oligonucleotides. Such enzymatic incorporation is useful when conjugates are used in post-synthetic enzymatic conjugation or selection reactions, (see for example Matulic-Adamic *et al.*, 2000, *Bioorg. Med. Chem. Lett.*, 10, 1299-1302; Lee *et al.*, 2001, *NAR.*, 29, 1565-1573; Joyce, 1989, *Gene*, 82, 83-87;  
25 Beaudry *et al.*, 1992, *Science* 257, 635-641; Joyce, 1992, *Scientific American* 267, 90-97; Breaker *et al.*, 1994, *TIBTECH* 12, 268; Bartel *et al.*, 1993, *Science* 261:1411-1418; Szostak, 1993, *TIBS* 17, 89-93; Kumar *et al.*, 1995, *FASEB J.*, 9, 1183; Breaker, 1996, *Curr. Op. Biotech.*, 7, 442; Santoro *et al.*, 1997, *Proc. Natl. Acad. Sci.*, 94, 4262; Tang *et al.*, 1997, *RNA* 3, 914; Nakamaye & Eckstein, 1994, *supra*; Long & Uhlenbeck, 1994, *supra*; Ishizaka  
30 *et al.*, 1995, *supra*; Vaish *et al.*, 1997, *Biochemistry* 36, 6495; Kuwabara *et al.*, 2000, *Curr. Opin. Chem. Biol.*, 4, 669).



The term "biodegradable linker" as used herein, refers to a nucleic acid or non-nucleic acid linker molecule that is designed as a biodegradable linker to connect one molecule to another molecule, for example, a biologically active molecule to a siNA molecule of the invention or the sense and antisense strands of a siNA molecule of the invention. The biodegradable linker is designed such that its stability can be modulated for a particular purpose, such as delivery to a particular tissue or cell type. The stability of a nucleic acid-based biodegradable linker molecule can be modulated by using various chemistries, for example combinations of ribonucleotides, deoxyribonucleotides, and chemically-modified nucleotides, such as 2'-O-methyl, 2'-fluoro, 2'-amino, 2'-O-amino, 2'-C-allyl, 2'-O-allyl, and other 2'-modified or base modified nucleotides. The biodegradable nucleic acid linker molecule can be a dimer, trimer, tetramer or longer nucleic acid molecule, for example, an oligonucleotide of about 2, 3, 4, 5, 6, 7, 8, 9, 10, 11, 12, 13, 14, 15, 16, 17, 18, 19, or 20 nucleotides in length, or can comprise a single nucleotide with a phosphorus-based linkage, for example, a phosphoramidate or phosphodiester linkage. The biodegradable nucleic acid linker molecule can also comprise nucleic acid backbone, nucleic acid sugar, or nucleic acid base modifications.

The term "biodegradable" as used herein, refers to degradation in a biological system, for example enzymatic degradation or chemical degradation.

The term "biologically active molecule" as used herein, refers to compounds or molecules that are capable of eliciting or modifying a biological response in a system. Non-limiting examples of biologically active siNA molecules either alone or in combination with other molecules contemplated by the instant invention include therapeutically active molecules such as antibodies, cholesterol, hormones, antivirals, peptides, proteins, chemotherapeutics, small molecules, vitamins, co-factors, nucleosides, nucleotides, oligonucleotides, enzymatic nucleic acids, antisense nucleic acids, triplex forming oligonucleotides, 2,5-A chimeras, siNA, dsRNA, allozymes, aptamers, decoys and analogs thereof. Biologically active molecules of the invention also include molecules capable of modulating the pharmacokinetics and/or pharmacodynamics of other biologically active molecules, for example, lipids and polymers such as polyamines, polyamides, polyethylene glycol and other polyethers.

The term "phospholipid" as used herein, refers to a hydrophobic molecule comprising at least one phosphorus group. For example, a phospholipid can comprise a phosphorus-containing group and saturated or unsaturated alkyl group, optionally substituted with OH, COOH, oxo, amine, or substituted or unsubstituted aryl groups.

5           The term "alkyl" as used herein refers to a saturated aliphatic hydrocarbon, including straight-chain, branched-chain "isoalkyl", and cyclic alkyl groups. The term "alkyl" also comprises alkoxy, alkyl-thio, alkyl-thio-alkyl, alkoxyalkyl, alkylamino, alkenyl, alkynyl, alkoxy, cycloalkenyl, cycloalkyl, cycloalkylalkyl, heterocycloalkyl, heteroaryl, C1-C6 hydrocarbyl, aryl or substituted aryl groups. Preferably, the alkyl group has 1 to 12 carbons.  
10 More preferably it is a lower alkyl of from about 1 to about 7 carbons, more preferably about 1 to about 4 carbons. The alkyl group can be substituted or unsubstituted. When substituted the substituted group(s) preferably comprise hydroxy, oxy, thio, amino, nitro, cyano, alkoxy, alkyl-thio, alkyl-thio-alkyl, alkoxyalkyl, alkylamino, silyl, alkenyl, alkynyl, alkoxy, cycloalkenyl, cycloalkyl, cycloalkylalkyl, heterocycloalkyl, heteroaryl, C1-C6  
15 hydrocarbyl, aryl or substituted aryl groups. The term "alkyl" also includes alkenyl groups containing at least one carbon-carbon double bond, including straight-chain, branched-chain, and cyclic groups. Preferably, the alkenyl group has about 2 to about 12 carbons. More preferably it is a lower alkenyl of from about 2 to about 7 carbons, more preferably about 2 to about 4 carbons. The alkenyl group can be substituted or  
20 unsubstituted. When substituted the substituted group(s) preferably comprise hydroxy, oxy, thio, amino, nitro, cyano, alkoxy, alkyl-thio, alkyl-thio-alkyl, alkoxyalkyl, alkylamino, silyl, alkenyl, alkynyl, alkoxy, cycloalkenyl, cycloalkyl, cycloalkylalkyl, heterocycloalkyl, heteroaryl, C1-C6 hydrocarbyl, aryl or substituted aryl groups. The term "alkyl" also includes alkynyl groups containing at least one carbon-carbon triple bond, including  
25 straight-chain, branched-chain, and cyclic groups. Preferably, the alkynyl group has about 2 to about 12 carbons. More preferably it is a lower alkynyl of from about 2 to about 7 carbons, more preferably about 2 to about 4 carbons. The alkynyl group can be substituted or unsubstituted. When substituted the substituted group(s) preferably comprise hydroxy, oxy, thio, amino, nitro, cyano, alkoxy, alkyl-thio, alkyl-thio-alkyl, alkoxyalkyl, alkylamino,  
30 silyl, alkenyl, alkynyl, alkoxy, cycloalkenyl, cycloalkyl, cycloalkylalkyl, heterocycloalkyl, heteroaryl, C1-C6 hydrocarbyl, aryl or substituted aryl groups. Alkyl groups or moieties of the invention can also include aryl, alkylaryl, carbocyclic aryl, heterocyclic aryl, amide and

ester groups. The preferred substituent(s) of aryl groups are halogen, trihalomethyl, hydroxyl, SH, OH, cyano, alkoxy, alkyl, alkenyl, alkynyl, and amino groups. An "alkylaryl" group refers to an alkyl group (as described above) covalently joined to an aryl group (as described above). Carbocyclic aryl groups are groups wherein the ring atoms on the aromatic ring are all carbon atoms. The carbon atoms are optionally substituted. Heterocyclic aryl groups are groups having from about 1 to about 3 heteroatoms as ring atoms in the aromatic ring and the remainder of the ring atoms are carbon atoms. Suitable heteroatoms include oxygen, sulfur, and nitrogen, and include furanyl, thienyl, pyridyl, pyrrolyl, N-lower alkyl pyrrolo, pyrimidyl, pyrazinyl, imidazolyl and the like, all optionally substituted. An "amide" refers to an -C(O)-NH-R, where R is either alkyl, aryl, alkylaryl or hydrogen. An "ester" refers to an -C(O)-OR', where R is either alkyl, aryl, alkylaryl or hydrogen.

The term "alkoxyalkyl" as used herein refers to an alkyl-O-alkyl ether, for example, methoxyethyl or ethoxymethyl.

15 The term "alkyl-thio-alkyl" as used herein refers to an alkyl-S-alkyl thioether, for example, methylthiomethyl or methylthioethyl.

The term "amino" as used herein refers to a nitrogen containing group as is known in the art derived from ammonia by the replacement of one or more hydrogen radicals by organic radicals. For example, the terms "aminoacyl" and "aminoalkyl" refer to specific N-substituted organic radicals with acyl and alkyl substituent groups respectively.

The term "amination" as used herein refers to a process in which an amino group or substituted amine is introduced into an organic molecule.

25 The term "exocyclic amine protecting moiety" as used herein refers to a nucleobase amino protecting group compatible with oligonucleotide synthesis, for example, an acyl or amide group.

The term "alkenyl" as used herein refers to a straight or branched hydrocarbon of a designed number of carbon atoms containing at least one carbon-carbon double bond. Examples of "alkenyl" include vinyl, allyl, and 2-methyl-3-heptene.

The term "alkoxy" as used herein refers to an alkyl group of indicated number of carbon atoms attached to the parent molecular moiety through an oxygen bridge. Examples of alkoxy groups include, for example, methoxy, ethoxy, propoxy and isopropoxy.

5 The term "alkynyl" as used herein refers to a straight or branched hydrocarbon of a designed number of carbon atoms containing at least one carbon-carbon triple bond. Examples of "alkynyl" include propargyl, propyne, and 3-hexyne.

The term "aryl" as used herein refers to an aromatic hydrocarbon ring system containing at least one aromatic ring. The aromatic ring can optionally be fused or otherwise attached to other aromatic hydrocarbon rings or non-aromatic hydrocarbon rings.  
10 Examples of aryl groups include, for example, phenyl, naphthyl, 1,2,3,4-tetrahydronaphthalene and biphenyl. Preferred examples of aryl groups include phenyl and naphthyl.

The term "cycloalkenyl" as used herein refers to a C3-C8 cyclic hydrocarbon containing at least one carbon-carbon double bond. Examples of cycloalkenyl include  
15 cyclopropenyl, cyclobutenyl, cyclopentenyl, cyclopentadiene, cyclohexenyl, 1,3-cyclohexadiene, cycloheptenyl, cycloheptatrienyl, and cyclooctenyl.

The term "cycloalkyl" as used herein refers to a C3-C8 cyclic hydrocarbon. Examples of cycloalkyl include cyclopropyl, cyclobutyl, cyclopentyl, cyclohexyl, cycloheptyl and cyclooctyl.

20 The term "cycloalkylalkyl," as used herein, refers to a C3-C7 cycloalkyl group attached to the parent molecular moiety through an alkyl group, as defined above. Examples of cycloalkylalkyl groups include cyclopropylmethyl and cyclopentylethyl.

The terms "halogen" or "halo" as used herein refers to indicate fluorine, chlorine, bromine, and iodine.

25 The term "heterocycloalkyl," as used herein refers to a non-aromatic ring system containing at least one heteroatom selected from nitrogen, oxygen, and sulfur. The heterocycloalkyl ring can be optionally fused to or otherwise attached to other heterocycloalkyl rings and/or non-aromatic hydrocarbon rings. Preferred heterocycloalkyl groups have from 3 to 7 members. Examples of heterocycloalkyl groups include, for

example, piperazine, morpholine, piperidine, tetrahydrofuran, pyrrolidine, and pyrazole. Preferred heterocycloalkyl groups include piperidinyl, piperazinyl, morpholinyl, and pyrrolidinyl.

The term "heteroaryl" as used herein refers to an aromatic ring system containing at least one heteroatom selected from nitrogen, oxygen, and sulfur. The heteroaryl ring can be fused or otherwise attached to one or more heteroaryl rings, aromatic or non-aromatic hydrocarbon rings or heterocycloalkyl rings. Examples of heteroaryl groups include, for example, pyridine, furan, thiophene, 5,6,7,8-tetrahydroisoquinoline and pyrimidine. Preferred examples of heteroaryl groups include thienyl, benzothienyl, pyridyl, quinolyl, pyrazinyl, pyrimidyl, imidazolyl, benzimidazolyl, furanyl, benzofuranyl, thiazolyl, benzothiazolyl, isoxazolyl, oxadiazolyl, isothiazolyl, benzisothiazolyl, triazolyl, tetrazolyl, pyrrolyl, indolyl, pyrazolyl, and benzopyrazolyl.

The term "C1-C6 hydrocarbyl" as used herein refers to straight, branched, or cyclic alkyl groups having 1-6 carbon atoms, optionally containing one or more carbon-carbon double or triple bonds. Examples of hydrocarbyl groups include, for example, methyl, ethyl, propyl, isopropyl, n-butyl, sec-butyl, tert-butyl, pentyl, 2-pentyl, isopentyl, neopentyl, hexyl, 2-hexyl, 3-hexyl, 3-methylpentyl, vinyl, 2-pentene, cyclopropylmethyl, cyclopropyl, cyclohexylmethyl, cyclohexyl and propargyl. When reference is made herein to C1-C6 hydrocarbyl containing one or two double or triple bonds it is understood that at least two carbons are present in the alkyl for one double or triple bond, and at least four carbons for two double or triple bonds.

The term "protecting group" as used herein, refers to groups known in the art that are readily introduced and removed from an atom, for example O, N, P, or S. Protecting groups are used to prevent undesirable reactions from taking place that can compete with the formation of a specific compound or intermediate of interest. See also "Protective Groups in Organic Synthesis", 3rd Ed., 1999, Greene, T. W. and related publications.

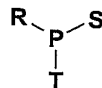
The term "nitrogen protecting group," as used herein, refers to groups known in the art that are readily introduced on to and removed from a nitrogen. Examples of nitrogen protecting groups include Boc, Cbz, benzoyl, and benzyl. See also "Protective Groups in Organic Synthesis", 3rd Ed., 1999, Greene, T. W. and related publications.

The term "hydroxy protecting group," or "hydroxy protection" as used herein, refers to groups known in the art that are readily introduced on to and removed from an oxygen, specifically an -OH group. Examples of hydroxy protecting groups include trityl or substituted trityl groups, such as monomethoxytrityl and dimethoxytrityl, or substituted silyl groups, such as tert-butyldimethyl, trimethylsilyl, or tert-butyldiphenyl silyl groups. See also "Protective Groups in Organic Synthesis", 3rd Ed., 1999, Greene, T. W. and related publications.

The term "acyl" as used herein refers to -C(O)R groups, wherein R is an alkyl or aryl.

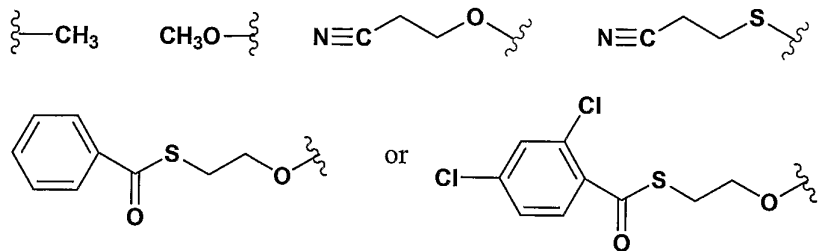
The term "phosphorus containing group" as used herein, refers to a chemical group containing a phosphorus atom. The phosphorus atom can be trivalent or pentavalent, and can be substituted with O, H, N, S, C or halogen atoms. Examples of phosphorus containing groups of the instant invention include but are not limited to phosphorus atoms substituted with O, H, N, S, C or halogen atoms, comprising phosphonate, alkylphosphonate, phosphate, diphosphate, triphosphate, pyrophosphate, phosphorothioate, phosphorodithioate, phosphoramidate, phosphoramidite groups, nucleotides and nucleic acid molecules.

The term "phosphine" or "phosphite" as used herein refers to a trivalent phosphorus species, for example compounds having Formula 97:

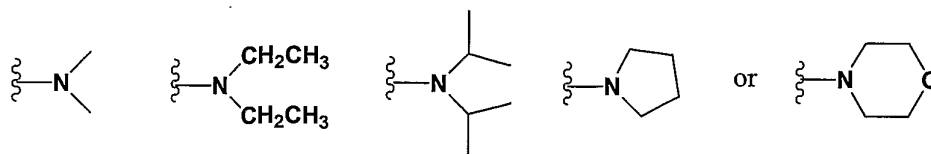


20

wherein R can include the groups:



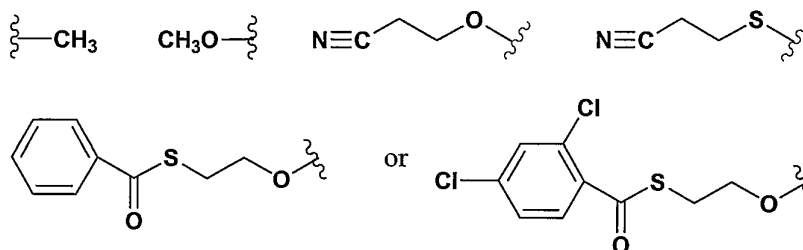
and wherein S and T independently include the groups:



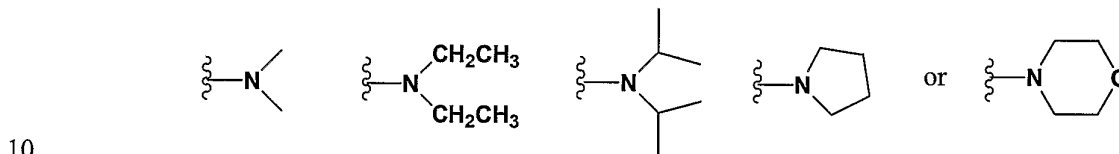
The term "phosphate" as used herein refers to a pentavalent phosphorus species, for example a compound having Formula 98:



wherein R includes the groups:



and wherein S and T each independently can be a sulfur or oxygen atom or a group which can include:



and wherein M comprises a sulfur or oxygen atom. The phosphate of the invention can comprise a nucleotide phosphate, wherein any R, S, or T in Formula 98 comprises a linkage to a nucleic acid or nucleoside.

15 The term "cationic salt" as used herein refers to any organic or inorganic salt having a net positive charge, for example a triethylammonium (TEA) salt.

The term "degradable linker" as used herein, refers to linker moieties that are capable of cleavage under various conditions. Conditions suitable for cleavage can include but are

not limited to pH, UV irradiation, enzymatic activity, temperature, hydrolysis, elimination, and substitution reactions, and thermodynamic properties of the linkage.

The term "photolabile linker" as used herein, refers to linker moieties as are known in the art, that are selectively cleaved under particular UV wavelengths. Compounds of the invention containing photolabile linkers can be used to deliver compounds to a target cell  
5 or tissue of interest, and can be subsequently released in the presence of a UV source.

The term "nucleic acid conjugates" as used herein, refers to nucleoside, nucleotide and oligonucleotide conjugates.

The term "lipid" as used herein, refers to any lipophilic compound. Non-limiting  
10 examples of lipid compounds include fatty acids and their derivatives, including straight chain, branched chain, saturated and unsaturated fatty acids, carotenoids, terpenes, bile acids, and steroids, including cholesterol and derivatives or analogs thereof.

The term "folate" as used herein, refers to analogs and derivatives of folic acid, for example antifolates, dihydrofolates, tetrahydrofolates, tetrahydropterins, folinic acid,  
15 pteropolyglutamic acid, 1-deaza, 3-deaza, 5-deaza, 8-deaza, 10-deaza, 1,5-deaza, 5,10 dideaza, 8,10-dideaza, and 5,8-dideaza folates, antifolates, and pteronic acid derivatives.

The term "compounds with neutral charge" as used herein, refers to compositions which are neutral or uncharged at neutral or physiological pH. Examples of such compounds are cholesterol and other steroids, cholesteryl hemisuccinate (CHEMS),  
20 dioleoyl phosphatidyl choline, distearoylphosphotidyl choline (DSPC), fatty acids such as oleic acid, phosphatidic acid and its derivatives, phosphatidyl serine, polyethylene glycol-conjugated phosphatidylamine, phosphatidylcholine, phosphatidylethanolamine and related variants, prenylated compounds including farnesol, polyprenols, tocopherol, and their modified forms, diacylsuccinyl glycerols, fusogenic or pore forming peptides,  
25 dioleoylphosphotidylethanolamine (DOPE), ceramide and the like.

The term "lipid aggregate" as used herein refers to a lipid-containing composition wherein the lipid is in the form of a liposome, micelle (non-lamellar phase) or other aggregates with one or more lipids.



The term "nitrogen containing group" as used herein refers to any chemical group or moiety comprising a nitrogen or substituted nitrogen. Non-limiting examples of nitrogen containing groups include amines, substituted amines, amides, alkylamines, amino acids such as arginine or lysine, polyamines such as spermine or spermidine, cyclic amines such as pyridines, pyrimidines including uracil, thymine, and cytosine, morpholines, phthalimides, and heterocyclic amines such as purines, including guanine and adenine.

Therapeutic nucleic acid molecules (e.g., siNA molecules) delivered exogenously optimally are stable within cells until reverse transcription of the RNA has been modulated long enough to reduce the levels of the RNA transcript. The nucleic acid molecules are resistant to nucleases in order to function as effective intracellular therapeutic agents. Improvements in the chemical synthesis of nucleic acid molecules described in the instant invention and in the art have expanded the ability to modify nucleic acid molecules by introducing nucleotide modifications to enhance their nuclease stability as described above.

In yet another embodiment, siNA molecules having chemical modifications that maintain or enhance enzymatic activity of proteins involved in RNAi are provided. Such nucleic acids are also generally more resistant to nucleases than unmodified nucleic acids. Thus, *in vitro* and/or *in vivo* the activity should not be significantly lowered.

Use of the nucleic acid-based molecules of the invention will lead to better treatment of the disease progression by affording the possibility of combination therapies (e.g., multiple siNA molecules targeted to different genes; nucleic acid molecules coupled with known small molecule modulators; or intermittent treatment with combinations of molecules, including different motifs and/or other chemical or biological molecules). The treatment of subjects with siNA molecules can also include combinations of different types of nucleic acid molecules, such as enzymatic nucleic acid molecules (ribozymes), allozymes, antisense, 2,5-A oligoadenylate, decoys, and aptamers.

In another aspect a siNA molecule of the invention comprises one or more 5' and/or a 3'- cap structure, for example on only the sense siNA strand, the antisense siNA strand, or both siNA strands.

By "cap structure" is meant chemical modifications, which have been incorporated at either terminus of the oligonucleotide (see, for example, Adamic *et al.*, U.S. Pat. No. 5,998,203, incorporated by reference herein). These terminal modifications protect the nucleic acid molecule from exonuclease degradation, and can help in delivery and/or  
5 localization within a cell. The cap can be present at the 5'-terminus (5'-cap) or at the 3'-terminal (3'-cap) or can be present on both termini. Non-limiting examples of the 5'-cap include, but are not limited to, glyceryl, inverted deoxy abasic residue (moiety); 4',5'-methylene nucleotide; 1-(beta-D-erythrofuransyl) nucleotide, 4'-thio nucleotide; carbocyclic nucleotide; 1,5-anhydrohexitol nucleotide; L-nucleotides; alpha-nucleotides;  
10 modified base nucleotide; phosphorodithioate linkage; *threo*-pentofuransyl nucleotide; acyclic 3',4'-seco nucleotide; acyclic 3,4-dihydroxybutyl nucleotide; acyclic 3,5-dihydroxypentyl nucleotide, 3'-3'-inverted nucleotide moiety; 3'-3'-inverted abasic moiety; 3'-2'-inverted nucleotide moiety; 3'-2'-inverted abasic moiety; 1,4-butanediol phosphate; 3'-phosphoramidate; hexylphosphate; aminohexyl phosphate; 3'-phosphate;  
15 3'-phosphorothioate; phosphorodithioate; or bridging or non-bridging methylphosphonate moiety.

Non-limiting examples of the 3'-cap include, but are not limited to, glyceryl, inverted deoxy abasic residue (moiety), 4', 5'-methylene nucleotide; 1-(beta-D-erythrofuransyl) nucleotide; 4'-thio nucleotide, carbocyclic nucleotide; 5'-amino-alkyl phosphate;  
20 1,3-diamino-2-propyl phosphate; 3-aminopropyl phosphate; 6-aminohexyl phosphate; 1,2-aminododecyl phosphate; hydroxypropyl phosphate; 1,5-anhydrohexitol nucleotide; L-nucleotide; alpha-nucleotide; modified base nucleotide; phosphorodithioate; *threo*-pentofuransyl nucleotide; acyclic 3',4'-seco nucleotide; 3,4-dihydroxybutyl nucleotide; 3,5-dihydroxypentyl nucleotide, 5'-5'-inverted nucleotide moiety; 5'-5'-inverted  
25 abasic moiety; 5'-phosphoramidate; 5'-phosphorothioate; 1,4-butanediol phosphate; 5'-amino; bridging and/or non-bridging 5'-phosphoramidate, phosphorothioate and/or phosphorodithioate, bridging or non bridging methylphosphonate and 5'-mercapto moieties (for more details see Beaucage and Iyer, 1993, *Tetrahedron* 49, 1925; incorporated by reference herein).

30 By the term "non-nucleotide" is meant any group or compound which can be incorporated into a nucleic acid chain in the place of one or more nucleotide units, including either sugar and/or phosphate substitutions, and allows the remaining bases to

exhibit their enzymatic activity. The group or compound is abasic in that it does not contain a commonly recognized nucleotide base, such as adenosine, guanine, cytosine, uracil or thymine and therefore lacks a base at the 1'-position.

By "nucleotide" as used herein is as recognized in the art to include natural bases  
5 (standard), and modified bases well known in the art. Such bases are generally located at the 1' position of a nucleotide sugar moiety. Nucleotides generally comprise a base, sugar and a phosphate group. The nucleotides can be unmodified or modified at the sugar, phosphate and/or base moiety, (also referred to interchangeably as nucleotide analogs, modified nucleotides, non-natural nucleotides, non-standard nucleotides and other; see, for  
10 example, Usman and McSwiggen, *supra*; Eckstein *et al.*, International PCT Publication No. WO 92/07065; Usman *et al.*, International PCT Publication No. WO 93/15187; Uhlman & Peyman, *supra*, all are hereby incorporated by reference herein). There are several examples of modified nucleic acid bases known in the art as summarized by Limbach *et al.*,  
15 1994, *Nucleic Acids Res.* 22, 2183. Some of the non-limiting examples of base modifications that can be introduced into nucleic acid molecules include, inosine, purine, pyridin-4-one, pyridin-2-one, phenyl, pseudouracil, 2, 4, 6-trimethoxy benzene, 3-methyl uracil, dihydrouridine, naphthyl, aminophenyl, 5-alkylcytidines (*e.g.*, 5-methylcytidine),  
20 5-alkyluridines (*e.g.*, ribothymidine), 5-halouridine (*e.g.*, 5-bromouridine) or 6-azapyrimidines or 6-alkylpyrimidines (*e.g.*, 6-methyluridine), propyne, and others (Burgin *et al.*, 1996, *Biochemistry*, 35, 14090; Uhlman & Peyman, *supra*). By "modified bases" in this aspect is meant nucleotide bases other than adenine, guanine, cytosine and uracil at 1' position or their equivalents.

In one embodiment, the invention features modified siNA molecules, with phosphate backbone modifications comprising one or more phosphorothioate, phosphonoacetate,  
25 and/or thiophosphonoacetate, phosphorodithioate, methylphosphonate, phosphotriester, morpholino, amidate carbamate, carboxymethyl, acetamidate, polyamide, sulfonate, sulfonamide, sulfamate, formacetal, thioformacetal, and/or alkylsilyl, substitutions. For a review of oligonucleotide backbone modifications, see Hunziker and Leumann, 1995, *Nucleic Acid Analogues: Synthesis and Properties*, in *Modern Synthetic Methods*, VCH,  
30 331-417, and Mesmaeker *et al.*, 1994, *Novel Backbone Replacements for Oligonucleotides*, in *Carbohydrate Modifications in Antisense Research*, ACS, 24-39.

By "abasic" is meant sugar moieties lacking a base or having other chemical groups in place of a base at the 1' position, see for example Adamic *et al.*, U.S. Pat. No. 5,998,203.

By "unmodified nucleoside" is meant one of the bases adenine, cytosine, guanine, thymine, or uracil joined to the 1' carbon of  $\beta$ -D-ribo-furanose.

5 By "modified nucleoside" is meant any nucleotide base which contains a modification in the chemical structure of an unmodified nucleotide base, sugar and/or phosphate. Non-limiting examples of modified nucleotides are shown by Formulae I-VII and/or other modifications described herein.

In connection with 2'-modified nucleotides as described for the present invention, by  
10 "amino" is meant 2'-NH<sub>2</sub> or 2'-O-NH<sub>2</sub>, which can be modified or unmodified. Such modified groups are described, for example, in Eckstein *et al.*, U.S. Pat. No. 5,672,695 and Matulic-Adamic *et al.*, U.S. Pat. No. 6,248,878, which are both incorporated by reference in their entireties.

Various modifications to nucleic acid siNA structure can be made to enhance the  
15 utility of these molecules. Such modifications will enhance shelf-life, half-life *in vitro*, stability, and ease of introduction of such oligonucleotides to the target site, *e.g.*, to enhance penetration of cellular membranes, and confer the ability to recognize and bind to targeted cells.

#### Administration of Nucleic Acid Molecules

20 A siNA molecule of the invention can be adapted for use to treat any disease, infection or condition associated with gene expression, and other indications that can respond to the level of gene product in a cell or tissue, alone or in combination with other therapies. Non-limiting examples of such diseases and conditions include cancer or cancerous disease, infectious disease, cardiovascular disease, neurologic disease, ocular  
25 disease, prion disease, inflammatory disease, autoimmune disease, pulmonary disease, renal disease, liver disease, mitochondrial disease, endocrine disease, reproduction related diseases and conditions as are known in the art, and any other indications that can respond to the level of an expressed gene product in a cell or organism (see for example McSwiggen, International PCT Publication No. WO 03/74654). For example, a siNA molecule can

comprise a delivery vehicle, including liposomes, for administration to a subject, carriers and diluents and their salts, and/or can be present in pharmaceutically acceptable formulations. Methods for the delivery of nucleic acid molecules are described in Akhtar *et al.*, 1992, *Trends Cell Bio.*, 2, 139; *Delivery Strategies for Antisense Oligonucleotide Therapeutics*, ed. Akhtar, 1995, Maurer *et al.*, 1999, *Mol. Membr. Biol.*, 16, 129-140; Hofland and Huang, 1999, *Handb. Exp. Pharmacol.*, 137, 165-192; and Lee *et al.*, 2000, *ACS Symp. Ser.*, 752, 184-192, all of which are incorporated herein by reference. Beigelman *et al.*, U.S. Pat. No. 6,395,713 and Sullivan *et al.*, PCT WO 94/02595 further describe the general methods for delivery of nucleic acid molecules. These protocols can be utilized for the delivery of virtually any nucleic acid molecule. Nucleic acid molecules can be administered to cells by a variety of methods known to those of skill in the art, including, but not restricted to, encapsulation in liposomes, by iontophoresis, or by incorporation into other vehicles, such as biodegradable polymers, hydrogels, cyclodextrins (see for example Gonzalez *et al.*, 1999, *Bioconjugate Chem.*, 10, 1068-1074; Wang *et al.*, International PCT publication Nos. WO 03/47518 and WO 03/46185), poly(lactic-co-glycolic)acid (PLGA) and PLCA microspheres (see for example US Patent 6,447,796 and US Patent Application Publication No. US 2002130430), biodegradable nanocapsules, and bioadhesive microspheres, or by proteinaceous vectors (O'Hare and Normand, International PCT Publication No. WO 00/53722). In one embodiment, nucleic acid molecules or the invention are administered via biodegradable implant materials, such as elastic shape memory polymers (see for example Lendelein and Langer, 2002, *Science*, 296, 1673). In another embodiment, the nucleic acid molecules of the invention can also be formulated or complexed with polyethyleneimine and derivatives thereof, such as polyethyleneimine-polyethyleneglycol-N-acetylgalactosamine (PEI-PEG-GAL) or polyethyleneimine-polyethyleneglycol-tri-N-acetylgalactosamine (PEI-PEG-triGAL) derivatives. Alternatively, the nucleic acid/vehicle combination is locally delivered by direct injection or by use of an infusion pump. Direct injection of the nucleic acid molecules of the invention, whether subcutaneous, intramuscular, or intradermal, can take place using standard needle and syringe methodologies, or by needle-free technologies such as those described in Conry *et al.*, 1999, *Clin. Cancer Res.*, 5, 2330-2337 and Barry *et al.*, International PCT Publication No. WO 99/31262. Many examples in the art describe CNS delivery methods of oligonucleotides by osmotic pump, (see Chun *et al.*, 1998, *Neuroscience Letters*, 257, 135-138, D'Aldin *et al.*, 1998, *Mol. Brain Research*, 55,

151-164, Dryden *et al.*, 1998, *J. Endocrinol.*, 157, 169-175, Ghirnikar *et al.*, 1998, *Neuroscience Letters*, 247, 21-24) or direct infusion (Broaddus *et al.*, 1997, *Neurosurg. Focus*, 3, article 4). Other routes of delivery include, but are not limited to oral (tablet or pill form) and/or intrathecal delivery (Gold, 1997, *Neuroscience*, 76, 1153-1158). More  
5 detailed descriptions of nucleic acid delivery and administration are provided in Sullivan *et al.*, supra, Draper *et al.*, PCT WO93/23569, Beigelman *et al.*, PCT WO99/05094, and Klimuk *et al.*, PCT WO99/04819 all of which have been incorporated by reference herein. The molecules of the instant invention can be used as pharmaceutical agents. Pharmaceutical agents prevent, modulate the occurrence, or treat (alleviate a symptom to  
10 some extent, preferably all of the symptoms) of a disease state in a subject.

In addition, the invention features the use of methods to deliver the nucleic acid molecules of the instant invention to the central nervous system and/or peripheral nervous system. Experiments have demonstrated the efficient *in vivo* uptake of nucleic acids by neurons. As an example of local administration of nucleic acids to nerve cells, Sommer *et al.*, 1998, *Antisense Nuc. Acid Drug Dev.*, 8, 75, describe a study in which a 15mer  
15 phosphorothioate antisense nucleic acid molecule to c-fos is administered to rats via microinjection into the brain. Antisense molecules labeled with tetramethylrhodamine-isothiocyanate (TRITC) or fluorescein isothiocyanate (FITC) were taken up by exclusively by neurons thirty minutes post-injection. A diffuse cytoplasmic  
20 staining and nuclear staining was observed in these cells. As an example of systemic administration of nucleic acid to nerve cells, Epa *et al.*, 2000, *Antisense Nuc. Acid Drug Dev.*, 10, 469, describe an *in vivo* mouse study in which beta-cyclodextrin-adamantane-oligonucleotide conjugates were used to target the p75 neurotrophin receptor in neuronally differentiated PC12 cells. Following a two week  
25 course of IP administration, pronounced uptake of p75 neurotrophin receptor antisense was observed in dorsal root ganglion (DRG) cells. In addition, a marked and consistent down-regulation of p75 was observed in DRG neurons. Additional approaches to the targeting of nucleic acid to neurons are described in Broaddus *et al.*, 1998, *J. Neurosurg.*, 88(4), 734; Karle *et al.*, 1997, *Eur. J. Pharmacol.*, 340(2/3), 153; Bannai *et al.*, 1998, *Brain  
30 Research*, 784(1,2), 304; Rajakumar *et al.*, 1997, *Synapse*, 26(3), 199; Wu-pong *et al.*, 1999, *BioPharm*, 12(1), 32; Bannai *et al.*, 1998, *Brain Res. Protoc.*, 3(1), 83; Simantov *et al.*, 1996, *Neuroscience*, 74(1), 39. Nucleic acid molecules of the invention are therefore

amenable to delivery to and uptake by cells that express repeat expansion allelic variants for modulation of RE gene expression. The delivery of nucleic acid molecules of the invention, targeting RE is provided by a variety of different strategies. Traditional approaches to CNS delivery that can be used include, but are not limited to, intrathecal and  
5 intracerebroventricular administration, implantation of catheters and pumps, direct injection or perfusion at the site of injury or lesion, injection into the brain arterial system, or by chemical or osmotic opening of the blood-brain barrier. Other approaches can include the use of various transport and carrier systems, for example though the use of conjugates and biodegradable polymers. Furthermore, gene therapy approaches, for  
10 example as described in Kaplitt *et al.*, US 6,180,613 and Davidson, WO 04/013280, can be used to express nucleic acid molecules in the CNS.

In addition, the invention features the use of methods to deliver the nucleic acid molecules of the instant invention to hematopoietic cells, including monocytes and lymphocytes. These methods are described in detail by Hartmann *et al.*, 1998, *J. Pharmacol. Exp. Ther.*, 285(2), 920-928; Kronenwett *et al.*, 1998, *Blood*, 91(3), 852-862; Fillion and Phillips, 1997, *Biochim. Biophys. Acta.*, 1329(2), 345-356; Ma and Wei, 1996, *Leuk. Res.*, 20(11/12), 925-930; and Bongartz *et al.*, 1994, *Nucleic Acids Research*, 22(22), 4681-8. Such methods, as described above, include the use of free oligonucleotide, cationic lipid formulations, liposome formulations including pH sensitive liposomes and  
20 immunoliposomes, and bioconjugates including oligonucleotides conjugated to fusogenic peptides, for the transfection of hematopoietic cells with oligonucleotides.

In one embodiment, a compound, molecule, or composition for the treatment of ocular conditions (e.g., macular degeneration, diabetic retinopathy etc.) is administered to a subject intraocularly or by intraocular means. In another embodiment, a compound,  
25 molecule, or composition for the treatment of ocular conditions (e.g., macular degeneration, diabetic retinopathy etc.) is administered to a subject periocularly or by periocular means (see for example Ahlheim *et al.*, International PCT publication No. WO 03/24420). In one embodiment, a siNA molecule and/or formulation or composition thereof is administered to a subject intraocularly or by intraocular means. In another embodiment, a siNA  
30 molecule and/or formulation or composition thereof is administered to a subject periocularly or by periocular means. Periocular administration generally provides a less invasive approach to administering siNA molecules and formulation or composition

thereof to a subject (see for example Ahlheim et al., International PCT publication No. WO 03/24420). The use of periocular administration also minimizes the risk of retinal detachment, allows for more frequent dosing or administration, provides a clinically relevant route of administration for macular degeneration and other optic conditions, and also provides the possibility of using reservoirs (e.g., implants, pumps or other devices) for drug delivery.

In one embodiment, the siNA molecules of the invention and formulations or compositions thereof are administered directly or topically (e.g., locally) to the dermis or follicles as is generally known in the art (see for example Brand, 2001, *Curr. Opin. Mol. Ther.*, 3, 244-8; Regnier et al., 1998, *J. Drug Target*, 5, 275-89; Kanikkannan, 2002, *BioDrugs*, 16, 339-47; Wraight et al., 2001, *Pharmacol. Ther.*, 90, 89-104; and Preat and Dujardin, 2001, *STP PharmaSciences*, 11, 57-68).

In one embodiment, dermal delivery systems of the invention include, for example, aqueous and nonaqueous gels, creams, multiple emulsions, microemulsions, liposomes, ointments, aqueous and nonaqueous solutions, lotions, aerosols, hydrocarbon bases and powders, and can contain excipients such as solubilizers, permeation enhancers (e.g., fatty acids, fatty acid esters, fatty alcohols and amino acids), and hydrophilic polymers (e.g., polycarboxyl and polyvinylpyrrolidone). In one embodiment, the pharmaceutically acceptable carrier is a liposome or a transdermal enhancer. Examples of liposomes which can be used in this invention include the following: (1) CellFectin, 1:1.5 (M/M) liposome formulation of the cationic lipid N,N,N,N-tetramethyl-N,N,N,N-tetrapalmitoyl-spermine and dioleoyl phosphatidylethanolamine (DOPE) (GIBCO BRL); (2) Cytofectin GSV, 2:1 (M/M) liposome formulation of a cationic lipid and DOPE (Glen Research); (3) DOTAP (N-[1-(2,3-dioleoyloxy)-N,N,N-trimethyl-ammoniummethylsulfate] (Boehringer Mannheim); and (4) Lipofectamine, 3:1 (M/M) liposome formulation of the polycationic lipid DOSPA and the neutral lipid DOPE (GIBCO BRL).

In one embodiment, transmucosal delivery systems of the invention include patches, tablets, suppositories, pessaries, gels and creams, and can contain excipients such as solubilizers and enhancers (e.g., propylene glycol, bile salts and amino acids), and other vehicles (e.g., polyethylene glycol, fatty acid esters and derivatives, and hydrophilic polymers such as hydroxypropylmethylcellulose and hyaluronic acid).



In one embodiment, nucleic acid molecules of the invention are administered to the central nervous system (CNS) or peripheral nervous system (PNS). Experiments have demonstrated the efficient *in vivo* uptake of nucleic acids by neurons. As an example of local administration of nucleic acids to nerve cells, Sommer *et al.*, 1998, *Antisense Nuc. Acid Drug Dev.*, 8, 75, describe a study in which a 15mer phosphorothioate antisense nucleic acid molecule to *c-fos* is administered to rats via microinjection into the brain. Antisense molecules labeled with tetramethylrhodamine-isothiocyanate (TRITC) or fluorescein isothiocyanate (FITC) were taken up by exclusively by neurons thirty minutes post-injection. A diffuse cytoplasmic staining and nuclear staining was observed in these cells. As an example of systemic administration of nucleic acid to nerve cells, Epa *et al.*, 2000, *Antisense Nuc. Acid Drug Dev.*, 10, 469, describe an *in vivo* mouse study in which beta-cyclodextrin-adamantane-oligonucleotide conjugates were used to target the p75 neurotrophin receptor in neuronally differentiated PC12 cells. Following a two week course of IP administration, pronounced uptake of p75 neurotrophin receptor antisense was observed in dorsal root ganglion (DRG) cells. In addition, a marked and consistent down-regulation of p75 was observed in DRG neurons. Additional approaches to the targeting of nucleic acid to neurons are described in Broaddus *et al.*, 1998, *J. Neurosurg.*, 88(4), 734; Karle *et al.*, 1997, *Eur. J. Pharmacol.*, 340(2/3), 153; Bannai *et al.*, 1998, *Brain Research*, 784(1,2), 304; Rajakumar *et al.*, 1997, *Synapse*, 26(3), 199; Wu-pong *et al.*, 1999, *BioPharm*, 12(1), 32; Bannai *et al.*, 1998, *Brain Res. Protoc.*, 3(1), 83; Simantov *et al.*, 1996, *Neuroscience*, 74(1), 39. Nucleic acid molecules of the invention are therefore amenable to delivery to and uptake by cells in the CNS and/or PNS.

The delivery of nucleic acid molecules of the invention to the CNS is provided by a variety of different strategies. Traditional approaches to CNS delivery that can be used include, but are not limited to, intrathecal and intracerebroventricular administration, implantation of catheters and pumps, direct injection or perfusion at the site of injury or lesion, injection into the brain arterial system, or by chemical or osmotic opening of the blood-brain barrier. Other approaches can include the use of various transport and carrier systems, for example though the use of conjugates and biodegradable polymers. Furthermore, gene therapy approaches, for example as described in Kaplitt *et al.*, US 6,180,613 and Davidson, WO 04/013280, can be used to express nucleic acid molecules in the CNS.

In one embodiment, the nucleic acid molecules of the invention are administered via pulmonary delivery, such as by inhalation of an aerosol or spray dried formulation administered by an inhalation device or nebulizer, providing rapid local uptake of the nucleic acid molecules into relevant pulmonary tissues. Solid particulate compositions containing respirable dry particles of micronized nucleic acid compositions can be prepared by grinding dried or lyophilized nucleic acid compositions, and then passing the micronized composition through, for example, a 400 mesh screen to break up or separate out large agglomerates. A solid particulate composition comprising the nucleic acid compositions of the invention can optionally contain a dispersant which serves to facilitate the formation of an aerosol as well as other therapeutic compounds. A suitable dispersant is lactose, which can be blended with the nucleic acid compound in any suitable ratio, such as a 1 to 1 ratio by weight.

Aerosols of liquid particles comprising a nucleic acid composition of the invention can be produced by any suitable means, such as with a nebulizer (see for example US 4,501,729). Nebulizers are commercially available devices which transform solutions or suspensions of an active ingredient into a therapeutic aerosol mist either by means of acceleration of a compressed gas, typically air or oxygen, through a narrow venturi orifice or by means of ultrasonic agitation. Suitable formulations for use in nebulizers comprise the active ingredient in a liquid carrier in an amount of up to 40% w/w preferably less than 20% w/w of the formulation. The carrier is typically water or a dilute aqueous alcoholic solution, preferably made isotonic with body fluids by the addition of, for example, sodium chloride or other suitable salts. Optional additives include preservatives if the formulation is not prepared sterile, for example, methyl hydroxybenzoate, anti-oxidants, flavorings, volatile oils, buffering agents and emulsifiers and other formulation surfactants. The aerosols of solid particles comprising the active composition and surfactant can likewise be produced with any solid particulate aerosol generator. Aerosol generators for administering solid particulate therapeutics to a subject produce particles which are respirable, as explained above, and generate a volume of aerosol containing a predetermined metered dose of a therapeutic composition at a rate suitable for human administration. One illustrative type of solid particulate aerosol generator is an insufflator. Suitable formulations for administration by insufflation include finely comminuted powders which can be delivered by means of an insufflator. In the insufflator, the powder,

e.g., a metered dose thereof effective to carry out the treatments described herein, is contained in capsules or cartridges, typically made of gelatin or plastic, which are either pierced or opened in situ and the powder delivered by air drawn through the device upon inhalation or by means of a manually-operated pump. The powder employed in the  
5 insufflator consists either solely of the active ingredient or of a powder blend comprising the active ingredient, a suitable powder diluent, such as lactose, and an optional surfactant. The active ingredient typically comprises from 0.1 to 100 w/w of the formulation. A second type of illustrative aerosol generator comprises a metered dose inhaler. Metered dose inhalers are pressurized aerosol dispensers, typically containing a suspension or  
10 solution formulation of the active ingredient in a liquified propellant. During use these devices discharge the formulation through a valve adapted to deliver a metered volume to produce a fine particle spray containing the active ingredient. Suitable propellants include certain chlorofluorocarbon compounds, for example, dichlorodifluoromethane, trichlorofluoromethane, dichlorotetrafluoroethane and mixtures thereof. The formulation  
15 can additionally contain one or more co-solvents, for example, ethanol, emulsifiers and other formulation surfactants, such as oleic acid or sorbitan trioleate, anti-oxidants and suitable flavoring agents. Other methods for pulmonary delivery are described in, for example US Patent Application No. 20040037780, and US Patent Nos. 6,592,904; 6,582,728; 6,565,885.

20 In one embodiment, a siNA molecule of the invention is complexed with membrane disruptive agents such as those described in U.S. Patent Application Publication No. 20010007666, incorporated by reference herein in its entirety including the drawings. In another embodiment, the membrane disruptive agent or agents and the siNA molecule are also complexed with a cationic lipid or helper lipid molecule, such as those lipids described  
25 in U.S. Patent No. 6,235,310, incorporated by reference herein in its entirety including the drawings.

In one embodiment, siNA molecules of the invention are formulated or complexed with polyethylenimine (e.g., linear or branched PEI) and/or polyethylenimine derivatives, including for example grafted PEIs such as galactose PEI, cholesterol PEI, antibody  
30 derivatized PEI, and polyethylene glycol PEI (PEG-PEI) derivatives thereof (see for example Ogris *et al.*, 2001, *AAPA PharmSci*, 3, 1-11; Furgeson *et al.*, 2003, *Bioconjugate Chem.*, 14, 840-847; Kunath *et al.*, 2002, *Pharmaceutical Research*, 19, 810-817; Choi *et al.*,

2001, Bull. Korean Chem. Soc., 22, 46-52; Bettinger et al., 1999, Bioconjugate Chem., 10, 558-561; Peterson et al., 2002, Bioconjugate Chem., 13, 845-854; Erbacher et al., 1999, Journal of Gene Medicine Preprint, 1, 1-18; Godbey et al., 1999, PNAS USA, 96, 5177-5181; Godbey et al., 1999, Journal of Controlled Release, 60, 149-160; Diebold et al.,  
5 1999, Journal of Biological Chemistry, 274, 19087-19094; Thomas and Klibanov, 2002, PNAS USA, 99, 14640-14645; and Sagara, US 6,586,524, incorporated by reference herein.

In one embodiment, a siNA molecule of the invention comprises a bioconjugate, for example a nucleic acid conjugate as described in Vargeese et al., USSN 10/427,160, filed  
10 April 30, 2003; US 6,528,631; US 6,335,434; US 6, 235,886; US 6,153,737; US 5,214,136; US 5,138,045, all incorporated by reference herein.

Thus, the invention features a pharmaceutical composition comprising one or more nucleic acid(s) of the invention in an acceptable carrier, such as a stabilizer, buffer, and the like. The polynucleotides of the invention can be administered (*e.g.*, RNA, DNA or  
15 protein) and introduced into a subject by any standard means, with or without stabilizers, buffers, and the like, to form a pharmaceutical composition. When it is desired to use a liposome delivery mechanism, standard protocols for formation of liposomes can be followed. The compositions of the present invention can also be formulated and used as tablets, capsules or elixirs for oral administration, suppositories for rectal administration,  
20 sterile solutions, suspensions for injectable administration, and the other compositions known in the art.

The present invention also includes pharmaceutically acceptable formulations of the compounds described. These formulations include salts of the above compounds, *e.g.*, acid addition salts, for example, salts of hydrochloric, hydrobromic, acetic acid, and benzene  
25 sulfonic acid.

A pharmacological composition or formulation refers to a composition or formulation in a form suitable for administration, *e.g.*, systemic administration, into a cell or subject, including for example a human. Suitable forms, in part, depend upon the use or the route of entry, for example oral, transdermal, or by injection. Such forms should not  
30 prevent the composition or formulation from reaching a target cell (*i.e.*, a cell to which the negatively charged nucleic acid is desirable for delivery). For example, pharmacological

compositions injected into the blood stream should be soluble. Other factors are known in the art, and include considerations such as toxicity and forms that prevent the composition or formulation from exerting its effect.

By "systemic administration" is meant *in vivo* systemic absorption or accumulation  
5 of drugs in the blood stream followed by distribution throughout the entire body. Administration routes that lead to systemic absorption include, without limitation: intravenous, subcutaneous, intraperitoneal, inhalation, oral, intrapulmonary and intramuscular. Each of these administration routes exposes the siNA molecules of the invention to an accessible diseased tissue. The rate of entry of a drug into the circulation  
10 has been shown to be a function of molecular weight or size. The use of a liposome or other drug carrier comprising the compounds of the instant invention can potentially localize the drug, for example, in certain tissue types, such as the tissues of the reticular endothelial system (RES). A liposome formulation that can facilitate the association of drug with the surface of cells, such as, lymphocytes and macrophages is also useful. This approach can  
15 provide enhanced delivery of the drug to target cells by taking advantage of the specificity of macrophage and lymphocyte immune recognition of abnormal cells, such as cancer cells.

By "pharmaceutically acceptable formulation" is meant a composition or formulation that allows for the effective distribution of the nucleic acid molecules of the instant  
20 invention in the physical location most suitable for their desired activity. Non-limiting examples of agents suitable for formulation with the nucleic acid molecules of the instant invention include: P-glycoprotein inhibitors (such as Pluronic P85), which can enhance entry of drugs into the CNS (Jolliet-Riant and Tillement, 1999, *Fundam. Clin. Pharmacol.*, 13, 16-26); biodegradable polymers, such as poly (DL-lactide-coglycolide) microspheres  
25 for sustained release delivery after intracerebral implantation (Emerich, DF *et al*, 1999, *Cell Transplant*, 8, 47-58) (Alkermes, Inc. Cambridge, MA); and loaded nanoparticles, such as those made of polybutylcyanoacrylate, which can deliver drugs across the blood brain barrier and can alter neuronal uptake mechanisms (*Prog Neuropsychopharmacol Biol Psychiatry*, 23, 941-949, 1999). Other non-limiting examples of delivery strategies for the  
30 nucleic acid molecules of the instant invention include material described in Boado *et al.*, 1998, *J. Pharm. Sci.*, 87, 1308-1315; Tyler *et al.*, 1999, *FEBS Lett.*, 421, 280-284; Pardridge *et al.*, 1995, *PNAS USA.*, 92, 5592-5596; Boado, 1995, *Adv. Drug Delivery Rev.*,

15, 73-107; Aldrian-Herrada *et al.*, 1998, *Nucleic Acids Res.*, 26, 4910-4916; and Tyler *et al.*, 1999, *PNAS USA.*, 96, 7053-7058.

The invention also features the use of the composition comprising surface-modified liposomes containing poly (ethylene glycol) lipids (PEG-modified, or long-circulating liposomes or stealth liposomes). These formulations offer a method for increasing the accumulation of drugs in target tissues. This class of drug carriers resists opsonization and elimination by the mononuclear phagocytic system (MPS or RES), thereby enabling longer blood circulation times and enhanced tissue exposure for the encapsulated drug (Lasic *et al. Chem. Rev.* 1995, 95, 2601-2627; Ishiwata *et al.*, *Chem. Pharm. Bull.* 1995, 43, 1005-1011).  
5 Such liposomes have been shown to accumulate selectively in tumors, presumably by extravasation and capture in the neovascularized target tissues (Lasic *et al.*, *Science* 1995, 267, 1275-1276; Oku *et al.*, 1995, *Biochim. Biophys. Acta*, 1238, 86-90). The long-circulating liposomes enhance the pharmacokinetics and pharmacodynamics of DNA and RNA, particularly compared to conventional cationic liposomes which are known to  
10 accumulate in tissues of the MPS (Liu *et al.*, *J. Biol. Chem.* 1995, 42, 24864-24870; Choi *et al.*, International PCT Publication No. WO 96/10391; Ansell *et al.*, International PCT Publication No. WO 96/10390; Holland *et al.*, International PCT Publication No. WO 96/10392). Long-circulating liposomes are also likely to protect drugs from nuclease degradation to a greater extent compared to cationic liposomes, based on their ability to  
15 avoid accumulation in metabolically aggressive MPS tissues such as the liver and spleen.  
20

The present invention also includes compositions prepared for storage or administration that include a pharmaceutically effective amount of the desired compounds in a pharmaceutically acceptable carrier or diluent. Acceptable carriers or diluents for therapeutic use are well known in the pharmaceutical art, and are described, for example, in  
25 *Remington's Pharmaceutical Sciences*, Mack Publishing Co. (A.R. Gennaro edit. 1985), hereby incorporated by reference herein. For example, preservatives, stabilizers, dyes and flavoring agents can be provided. These include sodium benzoate, sorbic acid and esters of *p*-hydroxybenzoic acid. In addition, antioxidants and suspending agents can be used.

A pharmaceutically effective dose is that dose required to prevent, inhibit the  
30 occurrence, or treat (alleviate a symptom to some extent, preferably all of the symptoms) of a disease state. The pharmaceutically effective dose depends on the type of disease, the

composition used, the route of administration, the type of mammal being treated, the physical characteristics of the specific mammal under consideration, concurrent medication, and other factors that those skilled in the medical arts will recognize. Generally, an amount between 0.1 mg/kg and 100 mg/kg body weight/day of active ingredients is administered dependent upon potency of the negatively charged polymer.

The nucleic acid molecules of the invention and formulations thereof can be administered orally, topically, parenterally, by inhalation or spray, or rectally in dosage unit formulations containing conventional non-toxic pharmaceutically acceptable carriers, adjuvants and/or vehicles. The term parenteral as used herein includes percutaneous, subcutaneous, intravascular (*e.g.*, intravenous), intramuscular, or intrathecal injection or infusion techniques and the like. In addition, there is provided a pharmaceutical formulation comprising a nucleic acid molecule of the invention and a pharmaceutically acceptable carrier. One or more nucleic acid molecules of the invention can be present in association with one or more non-toxic pharmaceutically acceptable carriers and/or diluents and/or adjuvants, and if desired other active ingredients. The pharmaceutical compositions containing nucleic acid molecules of the invention can be in a form suitable for oral use, for example, as tablets, troches, lozenges, aqueous or oily suspensions, dispersible powders or granules, emulsion, hard or soft capsules, or syrups or elixirs.

Compositions intended for oral use can be prepared according to any method known to the art for the manufacture of pharmaceutical compositions and such compositions can contain one or more such sweetening agents, flavoring agents, coloring agents or preservative agents in order to provide pharmaceutically elegant and palatable preparations. Tablets contain the active ingredient in admixture with non-toxic pharmaceutically acceptable excipients that are suitable for the manufacture of tablets. These excipients can be, for example, inert diluents; such as calcium carbonate, sodium carbonate, lactose, calcium phosphate or sodium phosphate; granulating and disintegrating agents, for example, corn starch, or alginic acid; binding agents, for example starch, gelatin or acacia; and lubricating agents, for example magnesium stearate, stearic acid or talc. The tablets can be uncoated or they can be coated by known techniques. In some cases such coatings can be prepared by known techniques to delay disintegration and absorption in the gastrointestinal tract and thereby provide a sustained action over a longer period. For

example, a time delay material such as glyceryl monosterate or glyceryl distearate can be employed.

Formulations for oral use can also be presented as hard gelatin capsules wherein the active ingredient is mixed with an inert solid diluent, for example, calcium carbonate, calcium phosphate or kaolin, or as soft gelatin capsules wherein the active ingredient is  
5 mixed with water or an oil medium, for example peanut oil, liquid paraffin or olive oil.

Aqueous suspensions contain the active materials in a mixture with excipients suitable for the manufacture of aqueous suspensions. Such excipients are suspending agents, for example sodium carboxymethylcellulose, methylcellulose,  
10 hydropropyl-methylcellulose, sodium alginate, polyvinylpyrrolidone, gum tragacanth and gum acacia; dispersing or wetting agents can be a naturally-occurring phosphatide, for example, lecithin, or condensation products of an alkylene oxide with fatty acids, for example polyoxyethylene stearate, or condensation products of ethylene oxide with long  
15 chain aliphatic alcohols, for example heptadecaethyleneoxycetanol, or condensation products of ethylene oxide with partial esters derived from fatty acids and a hexitol such as polyoxyethylene sorbitol monooleate, or condensation products of ethylene oxide with partial esters derived from fatty acids and hexitol anhydrides, for example polyethylene  
20 sorbitan monooleate. The aqueous suspensions can also contain one or more preservatives, for example ethyl, or n-propyl p-hydroxybenzoate, one or more coloring agents, one or more flavoring agents, and one or more sweetening agents, such as sucrose or saccharin.

Oily suspensions can be formulated by suspending the active ingredients in a vegetable oil, for example arachis oil, olive oil, sesame oil or coconut oil, or in a mineral oil such as liquid paraffin. The oily suspensions can contain a thickening agent, for example  
25 beeswax, hard paraffin or cetyl alcohol. Sweetening agents and flavoring agents can be added to provide palatable oral preparations. These compositions can be preserved by the addition of an anti-oxidant such as ascorbic acid

Dispersible powders and granules suitable for preparation of an aqueous suspension by the addition of water provide the active ingredient in admixture with a dispersing or wetting agent, suspending agent and one or more preservatives. Suitable dispersing or  
30 wetting agents or suspending agents are exemplified by those already mentioned above.



Additional excipients, for example sweetening, flavoring and coloring agents, can also be present.

Pharmaceutical compositions of the invention can also be in the form of oil-in-water emulsions. The oily phase can be a vegetable oil or a mineral oil or mixtures of these. Suitable emulsifying agents can be naturally-occurring gums, for example gum acacia or gum tragacanth, naturally-occurring phosphatides, for example soy bean, lecithin, and esters or partial esters derived from fatty acids and hexitol, anhydrides, for example sorbitan monooleate, and condensation products of the said partial esters with ethylene oxide, for example polyoxyethylene sorbitan monooleate. The emulsions can also contain sweetening and flavoring agents.

Syrups and elixirs can be formulated with sweetening agents, for example glycerol, propylene glycol, sorbitol, glucose or sucrose. Such formulations can also contain a demulcent, a preservative and flavoring and coloring agents. The pharmaceutical compositions can be in the form of a sterile injectable aqueous or oleaginous suspension. This suspension can be formulated according to the known art using those suitable dispersing or wetting agents and suspending agents that have been mentioned above. The sterile injectable preparation can also be a sterile injectable solution or suspension in a non-toxic parentally acceptable diluent or solvent, for example as a solution in 1,3-butanediol. Among the acceptable vehicles and solvents that can be employed are water, Ringer's solution and isotonic sodium chloride solution. In addition, sterile, fixed oils are conventionally employed as a solvent or suspending medium. For this purpose, any bland fixed oil can be employed including synthetic mono-or diglycerides. In addition, fatty acids such as oleic acid find use in the preparation of injectables.

The nucleic acid molecules of the invention can also be administered in the form of suppositories, *e.g.*, for rectal administration of the drug. These compositions can be prepared by mixing the drug with a suitable non-irritating excipient that is solid at ordinary temperatures but liquid at the rectal temperature and will therefore melt in the rectum to release the drug. Such materials include cocoa butter and polyethylene glycols.

Nucleic acid molecules of the invention can be administered parenterally in a sterile medium. The drug, depending on the vehicle and concentration used, can either be

suspended or dissolved in the vehicle. Advantageously, adjuvants such as local anesthetics, preservatives and buffering agents can be dissolved in the vehicle.

Dosage levels of the order of from about 0.1 mg to about 140 mg per kilogram of body weight per day are useful in the treatment of the above-indicated conditions (about 0.5  
5 mg to about 7 g per subject per day). The amount of active ingredient that can be combined with the carrier materials to produce a single dosage form varies depending upon the host treated and the particular mode of administration. Dosage unit forms generally contain between from about 1 mg to about 500 mg of an active ingredient.

It is understood that the specific dose level for any particular subject depends upon a  
10 variety of factors including the activity of the specific compound employed, the age, body weight, general health, sex, diet, time of administration, route of administration, and rate of excretion, drug combination and the severity of the particular disease undergoing therapy.

For administration to non-human animals, the composition can also be added to the animal feed or drinking water. It can be convenient to formulate the animal feed and  
15 drinking water compositions so that the animal takes in a therapeutically appropriate quantity of the composition along with its diet. It can also be convenient to present the composition as a premix for addition to the feed or drinking water.

The nucleic acid molecules of the present invention can also be administered to a subject in combination with other therapeutic compounds to increase the overall  
20 therapeutic effect. The use of multiple compounds to treat an indication can increase the beneficial effects while reducing the presence of side effects.

In one embodiment, the invention comprises compositions suitable for administering nucleic acid molecules of the invention to specific cell types. For example, the asialoglycoprotein receptor (ASGPr) (Wu and Wu, 1987, *J. Biol. Chem.* 262, 4429-4432) is  
25 unique to hepatocytes and binds branched galactose-terminal glycoproteins, such as asialoorosomuroid (ASOR). In another example, the folate receptor is overexpressed in many cancer cells. Binding of such glycoproteins, synthetic glycoconjugates, or folates to the receptor takes place with an affinity that strongly depends on the degree of branching of the oligosaccharide chain, for example, triantennary structures are bound with greater  
30 affinity than biantennary or monoantennary chains (Baenziger and Fiete, 1980, *Cell*, 22,

611-620; Connolly *et al.*, 1982, *J. Biol. Chem.*, 257, 939-945). Lee and Lee, 1987, *Glycoconjugate J.*, 4, 317-328, obtained this high specificity through the use of N-acetyl-D-galactosamine as the carbohydrate moiety, which has higher affinity for the receptor, compared to galactose. This "clustering effect" has also been described for the  
5 binding and uptake of mannosyl-terminating glycoproteins or glycoconjugates (Ponpipom *et al.*, 1981, *J. Med. Chem.*, 24, 1388-1395). The use of galactose, galactosamine, or folate based conjugates to transport exogenous compounds across cell membranes can provide a targeted delivery approach to, for example, the treatment of liver disease, cancers of the liver, or other cancers. The use of bioconjugates can also provide a reduction in the  
10 required dose of therapeutic compounds required for treatment. Furthermore, therapeutic bioavailability, pharmacodynamics, and pharmacokinetic parameters can be modulated through the use of nucleic acid bioconjugates of the invention. Non-limiting examples of such bioconjugates are described in Vargeese *et al.*, USSN 10/201,394, filed August 13, 2001; and Matulic-Adamic *et al.*, USSN 10/151,116, filed May 17, 2002. In one  
15 embodiment, nucleic acid molecules of the invention are complexed with or covalently attached to nanoparticles, such as Hepatitis B virus S, M, or L envelope proteins (see for example Yamado *et al.*, 2003, *Nature Biotechnology*, 21, 885). In one embodiment, nucleic acid molecules of the invention are delivered with specificity for human tumor cells, specifically non-apoptotic human tumor cells including for example T-cells, hepatocytes,  
20 breast carcinoma cells, ovarian carcinoma cells, melanoma cells, intestinal epithelial cells, prostate cells, testicular cells, non-small cell lung cancers, small cell lung cancers, etc.

In one embodiment, a siNA molecule of the invention is designed or formulated to specifically target endothelial cells or tumor cells. For example, various formulations and conjugates can be utilized to specifically target endothelial cells or tumor cells, including  
25 PEI-PEG-folate, PEI-PEG-RGD, PEI-PEG-biotin, PEI-PEG-cholesterol, and other conjugates known in the art that enable specific targeting to endothelial cells and/or tumor cells.

#### Examples:

The following are non-limiting examples showing the selection, isolation, synthesis  
30 and activity of nucleic acids of the instant invention.

Example 1: Tandem synthesis of siNA constructs

Exemplary siNA molecules of the invention are synthesized in tandem using a cleavable linker, for example, a succinyl-based linker. Tandem synthesis as described herein is followed by a one-step purification process that provides RNAi molecules in high yield. This approach is highly amenable to siNA synthesis in support of high throughput RNAi screening, and can be readily adapted to multi-column or multi-well synthesis platforms.

After completing a tandem synthesis of a siNA oligo and its complement in which the 5'-terminal dimethoxytrityl (5'-O-DMT) group remains intact (trityl on synthesis), the oligonucleotides are deprotected as described above. Following deprotection, the siNA sequence strands are allowed to spontaneously hybridize. This hybridization yields a duplex in which one strand has retained the 5'-O-DMT group while the complementary strand comprises a terminal 5'-hydroxyl. The newly formed duplex behaves as a single molecule during routine solid-phase extraction purification (Trityl-On purification) even though only one molecule has a dimethoxytrityl group. Because the strands form a stable duplex, this dimethoxytrityl group (or an equivalent group, such as other trityl groups or other hydrophobic moieties) is all that is required to purify the pair of oligos, for example, by using a C18 cartridge.

Standard phosphoramidite synthesis chemistry is used up to the point of introducing a tandem linker, such as an inverted deoxy abasic succinate or glyceryl succinate linker (see **Figure 1**) or an equivalent cleavable linker. A non-limiting example of linker coupling conditions that can be used includes a hindered base such as diisopropylethylamine (DIPA) and/or DMAP in the presence of an activator reagent such as Bromotripyrrolidinophosphoniumhexafluorophosphate (PyBrOP). After the linker is coupled, standard synthesis chemistry is utilized to complete synthesis of the second sequence leaving the terminal the 5'-O-DMT intact. Following synthesis, the resulting oligonucleotide is deprotected according to the procedures described herein and quenched with a suitable buffer, for example with 50mM NaOAc or 1.5M NH<sub>4</sub>H<sub>2</sub>CO<sub>3</sub>.

Purification of the siNA duplex can be readily accomplished using solid phase extraction, for example using a Waters C18 SepPak 1g cartridge conditioned with 1 column volume (CV) of acetonitrile, 2 CV H<sub>2</sub>O, and 2 CV 50mM NaOAc. The sample is loaded

and then washed with 1 CV H<sub>2</sub>O or 50mM NaOAc. Failure sequences are eluted with 1 CV 14% ACN (Aqueous with 50mM NaOAc and 50mM NaCl). The column is then washed, for example with 1 CV H<sub>2</sub>O followed by on-column detritylation, for example by passing 1 CV of 1% aqueous trifluoroacetic acid (TFA) over the column, then adding a second CV of 1% aqueous TFA to the column and allowing to stand for approximately 10 minutes. The remaining TFA solution is removed and the column washed with H<sub>2</sub>O followed by 1 CV 1M NaCl and additional H<sub>2</sub>O. The siNA duplex product is then eluted, for example, using 1 CV 20% aqueous CAN.

**Figure 2** provides an example of MALDI-TOF mass spectrometry analysis of a purified siNA construct in which each peak corresponds to the calculated mass of an individual siNA strand of the siNA duplex. The same purified siNA provides three peaks when analyzed by capillary gel electrophoresis (CGE), one peak presumably corresponding to the duplex siNA, and two peaks presumably corresponding to the separate siNA sequence strands. Ion exchange HPLC analysis of the same siNA construct only shows a single peak. Testing of the purified siNA construct using a luciferase reporter assay described below demonstrated the same RNAi activity compared to siNA constructs generated from separately synthesized oligonucleotide sequence strands.

#### Example 2: Serum stability of chemically modified siNA constructs

Chemical modifications were introduced into siNA constructs to determine the stability of these constructs compared to native siNA oligonucleotides (containing two thymidine nucleotide overhangs) in human serum. An investigation of the serum stability of RNA duplexes revealed that siNA constructs consisting of all RNA nucleotides containing two thymidine nucleotide overhangs have a half-life in serum of 15 seconds, whereas chemically modified siNA constructs remained stable in serum for 1 to 3 days depending on the extent of modification (see Figure 3). RNAi stability tests were performed by internally labeling one strand (strand 1) of siNA and duplexing with 1.5 X the concentration of the complementary siNA strand (strand 2) (to insure all labeled material was in duplex form). Duplexed siNA constructs were then tested for stability by incubating at a final concentration of 2 $\mu$ M siNA (strand 2 concentration) in 90% mouse or human serum for time-points of 30sec, 1min, 5min, 30min, 90min, 4hrs 10min, 16hrs 24min, and

49hrs. Time points were run on a 15% denaturing polyacrylamide gels and analyzed on a phosphoimager.

Internal labeling was performed via kinase reactions with polynucleotide kinase (PNK) and  $^{32}\text{P}$ - $\gamma$ -ATP, with addition of radiolabeled phosphate at nucleotide 13 of strand 2, counting in from the 3' side. Ligation of the remaining 8-mer fragments with T4 RNA ligase resulted in the full length, 21-mer, strand 2. Duplexing of RNAi was done by adding appropriate concentrations of the siNA oligonucleotides and heating to 95° C for 5minutes followed by slow cooling to room temperature. Reactions were performed by adding 100% serum to the siNA duplexes and incubating at 37° C, then removing aliquots at desired time-points. Results of this study are summarized in **Figure 3**. As shown in the Figure 3, chemically modified siNA molecules have significantly increased serum stability compared to a siNA construct having all ribonucleotides except a 3'-terminal dithymidine (TT) modification.

#### Example 3: Identification of potential siNA target sites in any RNA sequence

The sequence of an RNA target of interest, such as a viral or human mRNA transcript, is screened for target sites, for example by using a computer folding algorithm. In a non-limiting example, the sequence of a gene or RNA gene transcript derived from a database, such as Genbank, is used to generate siNA targets having complementarity to the target. Such sequences can be obtained from a database, or can be determined experimentally as known in the art. Target sites that are known, for example, those target sites determined to be effective target sites based on studies with other nucleic acid molecules, for example ribozymes or antisense, or those targets known to be associated with a disease, condition, trait, genotype or phenotype such as those sites containing mutations or deletions, can be used to design siNA molecules targeting those sites. Various parameters can be used to determine which sites are the most suitable target sites within the target RNA sequence. These parameters include but are not limited to secondary or tertiary RNA structure, the nucleotide base composition of the target sequence, the degree of homology between various regions of the target sequence, or the relative position of the target sequence within the RNA transcript. Based on these determinations, any number of target sites within the RNA transcript can be chosen to screen siNA molecules for efficacy, for example by using *in vitro* RNA cleavage assays, cell culture, or animal models. In a

non-limiting example, anywhere from 1 to 1000 target sites are chosen within the transcript based on the size of the siNA construct to be used. High throughput screening assays can be developed for screening siNA molecules using methods known in the art, such as with multi-well or multi-plate assays or combinatorial/siNA library screening assays to  
5 determine efficient reduction in target gene expression.

Example 4: Selection of siNA molecule target sites in a RNA

The following non-limiting steps can be used to carry out the selection of siNAs targeting a given gene sequence or transcript.

The target sequence is parsed in silico into a list of all fragments or subsequences of a particular length, for example 23 nucleotide fragments, contained within the target  
10 sequence. This step is typically carried out using a custom Perl script, but commercial sequence analysis programs such as Oligo, MacVector, or the GCG Wisconsin Package can be employed as well.

In some instances the siNAs correspond to more than one target sequence; such  
15 would be the case for example in targeting different transcripts of the same gene, targeting different transcripts of more than one gene, or for targeting both the human gene and an animal homolog. In this case, a subsequence list of a particular length is generated for each of the targets, and then the lists are compared to find matching sequences in each list. The subsequences are then ranked according to the number of target sequences that contain the  
20 given subsequence; the goal is to find subsequences that are present in most or all of the target sequences. Alternately, the ranking can identify subsequences that are unique to a target sequence, such as a mutant target sequence. Such an approach would enable the use of siNA to target specifically the mutant sequence and not effect the expression of the normal sequence.

25 In some instances the siNA subsequences are absent in one or more sequences while present in the desired target sequence; such would be the case if the siNA targets a gene with a paralogous family member that is to remain untargeted. As in case 2 above, a subsequence list of a particular length is generated for each of the targets, and then the lists are compared to find sequences that are present in the target gene but are absent in the  
30 untargeted paralog.

The ranked siNA subsequences can be further analyzed and ranked according to GC content. A preference can be given to sites containing 30-70% GC, with a further preference to sites containing 40-60% GC.

5 The ranked siNA subsequences can be further analyzed and ranked according to self-folding and internal hairpins. Weaker internal folds are preferred; strong hairpin structures are to be avoided.

The ranked siNA subsequences can be further analyzed and ranked according to whether they have runs of GGG or CCC in the sequence. GGG (or even more Gs) in either strand can make oligonucleotide synthesis problematic and can potentially interfere with  
10 RNAi activity, so it is avoided other appropriately suitable sequences are available. CCC is searched in the target strand because that will place GGG in the antisense strand.

The ranked siNA subsequences can be further analyzed and ranked according to whether they have the dinucleotide UU (uridine dinucleotide) on the 3'-end of the sequence, and/or AA on the 5'-end of the sequence (to yield 3' UU on the antisense sequence). These  
15 sequences allow one to design siNA molecules with terminal TT thymidine dinucleotides.

Four or five target sites are chosen from the ranked list of subsequences as described above. For example, in subsequences having 23 nucleotides, the right 21 nucleotides of each chosen 23-mer subsequence are then designed and synthesized for the upper (sense) strand of the siNA duplex, while the reverse complement of the left 21 nucleotides of each  
20 chosen 23-mer subsequence are then designed and synthesized for the lower (antisense) strand of the siNA duplex (see Tables I). If terminal TT residues are desired for the sequence (as described in paragraph 7), then the two 3' terminal nucleotides of both the sense and antisense strands are replaced by TT prior to synthesizing the oligos.

The siNA molecules are screened in an in vitro, cell culture or animal model system  
25 to identify the most active siNA molecule or the most preferred target site within the target RNA sequence.

In an alternate approach, a pool of siNA constructs specific to a target sequence is used to screen for target sites in cells expressing target RNA, such as human HeLa cells. The general strategy used in this approach is shown in **Figure 21**. A non-limiting example



of such a pool is a pool comprising sequences having antisense sequences complementary to the target RNA sequence and sense sequences complementary to the antisense sequences. Cells (e.g., HeLa cells) expressing the target gene are transfected with the pool of siNA constructs and cells that demonstrate a phenotype associated with gene silencing are sorted.

5 The pool of siNA constructs can be chemically modified as described herein and synthesized, for example, in a high throughput manner. The siNA from cells demonstrating a positive phenotypic change (e.g., decreased target mRNA levels or target protein expression), are identified, for example by positional analysis within the assay, and are used to determine the most suitable target site(s) within the target RNA sequence based

10 upon the complementary sequence to the corresponding siNA antisense strand identified in the assay.

#### Example 5: RNAi activity of chemically modified siNA constructs

Short interfering nucleic acid (siNA) is emerging as a powerful tool for gene regulation. All-ribose siNA duplexes activate the RNAi pathway but have limited utility as

15 therapeutic compounds due to their nuclease sensitivity and short half-life in serum, as shown in Example 2 above. To develop nuclease-resistant siNA constructs for *in vivo* applications, siNAs that target luciferase mRNA and contain stabilizing chemical modifications were tested for activity in HeLa cells. The sequences for the siNA oligonucleotide sequences used in this study are shown in **Table I**. Modifications included

20 phosphorothioate linkages (P=S), 2'-O-methyl nucleotides, or 2'-fluoro (F) nucleotides in one or both siNA strands and various 3'-end stabilization chemistries, including 3'-glyceryl, 3'-inverted abasic, 3'-inverted Thymidine, and/or Thymidine. The RNAi activity of chemically stabilized siNA constructs was compared with the RNAi activity of control

25 siNA constructs consisting of all ribonucleotides at every position except the 3'-terminus which comprised two thymidine nucleotide overhangs. Active siNA molecules containing stabilizing modifications such as described herein should prove useful for *in vivo* applications, given their enhanced nuclease-resistance.

A luciferase reporter system was utilized to test RNAi activity of chemically modified siNA constructs compared to siNA constructs consisting of all RNA nucleotides

30 containing two thymidine nucleotide overhangs. Sense and antisense siNA strands (20  $\mu$ M each) were annealed by incubation in buffer (100 mM potassium acetate, 30 mM

HEPES-KOH, pH 7.4, 2 mM magnesium acetate) for 1 min. at 90°C followed by 1 hour at 37°C. Plasmids encoding firefly luciferase (pGL2) and renilla luciferase (pRLSV40) were purchased from Promega Biotech.

HeLa S3 cells were grown at 37°C in DMEM with 5% FBS and seeded at 15,300  
5 cells in 100 ul media per well of a 96-well plate 24 hours prior to transfection. For transfection, 4 ul Lipofectamine 2000 (Life Technologies) was added to 96 ul OPTI-MEM, vortexed and incubated at room temperature for 5 minutes. The 100 ul diluted lipid was then added to a microtiter tube containing 5 ul pGL2 (200ng/ul), 5 ul pRLSV40 (8 ng/ul) 6  
10 ul siNA (25 nM or 10 nM final), and 84 ul OPTI-MEM, vortexed briefly and incubated at room temperature for 20 minutes. The transfection mix was then mixed briefly and 50 ul was added to each of three wells that contained HeLa S3 cells in 100 ul media. Cells were incubated for 20 hours after transfection and analyzed for luciferase expression using the Dual luciferase assay according to the manufacturer's instructions (Promega Biotech). The results of this study are summarized in **Figures 4-16**. The sequences of the siNA strands  
15 used in this study are shown in Table I and are referred to by Sirna/RPI # in the figures. Normalized luciferase activity is reported as the ratio of firefly luciferase activity to renilla luciferase activity in the same sample. Error bars represent standard deviation of triplicate transfections. As shown in **Figures 4-16**, the RNAi activity of chemically modified constructs is often comparable to that of unmodified control siNA constructs, which consist  
20 of all ribonucleotides at every position except the 3'-terminus which comprises two thymidine nucleotide overhangs. In some instances, the RNAi activity of the chemically modified constructs is greater than the unmodified control siNA construct consisting of all ribonucleotides..

For example, **Figure 4** shows results obtained from a screen using phosphorothioate  
25 modified siNA constructs. The Sirna/RPI 27654/27659 construct contains phosphorothioate substitutions for every pyrimidine nucleotide in both sequences, the Sirna/RPI 27657/27662 construct contains 5 terminal 3'-phosphorothioate substitutions in each strand, the Sirna/RPI 27649/27658 construct contains all phosphorothioate substitutions only in the antisense strand, whereas the Sirna/RPI 27649/27660 and  
30 Sirna/RPI 27649/27661 constructs have unmodified sense strands and varying degrees of phosphorothioate substitutions in the antisense strand. All of these constructs show

significant RNAi activity when compared to a scrambled siNA control construct (27651/27652).

**Figure 5** shows results obtained from a screen using phosphorothioate (Sirna/RPI 28253/28255 and Sirna/RPI 28254/28256) and universal base substitutions (Sirna/RPI 28257/28259 and Sirna/RPI 28258/28260) compared to the same controls described above, these modifications show equivalent or better RNAi activity when compared to the unmodified control siNA construct.

**Figure 6** shows results obtained from a screen using 2'-O-methyl modified siNA constructs in which the sense strand contains either 10 (Sirna/RPI 28244/27650) or 5 (Sirna/RPI 28245/27650) 2'-O-methyl substitutions, both with comparable activity to the unmodified control siNA construct.

**Figure 7** shows results obtained from a screen using 2'-O-methyl or 2'-deoxy-2'-fluoro modified siNA constructs compared to a control construct consisting of all ribonucleotides at every position except the 3'-terminus which comprises two thymidine nucleotide overhangs.

**Figure 8** compares a siNA construct containing six phosphorothioate substitutions in each strand (Sirna/RPI 28460/28461), where 5 phosphorothioates are present at the 3' end and a single phosphorothioate is present at the 5' end of each strand. This motif shows very similar activity to the control siNA construct consisting of all ribonucleotides at every position except the 3'-terminus, which comprises two thymidine nucleotide overhangs.

**Figure 9** compares a siNA construct synthesized by the method of the invention described in Example 1, wherein an inverted deoxyabasic succinate linker was used to generate a siNA having a 3'-inverted deoxyabasic cap on the antisense strand of the siNA. This construct shows improved activity compared to the control siNA construct consisting of all ribonucleotides at every position except the 3'-terminus which comprises two thymidine nucleotide overhangs.

**Figure 10** shows the results of an RNAi activity screen of chemically modified siNA constructs including 3'-glyceryl modified siNA constructs compared to an all RNA control siNA construct using a luciferase reporter system. These chemically modified siNAs were

compared in the luciferase assay described herein at 1 nM and 10nM concentration using an all RNA siNA control (siGL2) having 3'-terminal dithymidine (TT) and its corresponding inverted control (Inv siGL2). The background level of luciferase expression in the HeLa cells is designated by the "cells" column. Sense and antisense strands of chemically modified siNA constructs are shown by Sirna/RPI number (sense strand/antisense strand). Sequences corresponding to these Sirna/RPI numbers are shown in Table I. As shown in the Figure, the 3'-terminal modified siNA constructs retain significant RNAi activity compared to the unmodified control siNA (siGL2) construct.

**Figure 11** shows the results of an RNAi activity screen of chemically modified siNA constructs. The screen compared various combinations of sense strand chemical modifications and antisense strand chemical modifications. These chemically modified siNAs were compared in the luciferase assay described herein at 1 nM and 10nM concentration using an all RNA siNA control (siGL2) having 3'-terminal dithymidine (TT) and its corresponding inverted control (Inv siGL2). The background level of luciferase expression in the HeLa cells is designated by the "cells" column. Sense and antisense strands of chemically modified siNA constructs are shown by Sirna/RPI number (sense strand/antisense strand). Sequences corresponding to these Sirna/RPI numbers are shown in Table I. As shown in the figure, the chemically modified Sirna/RPI 30063/30430, Sirna/RPI 30433/30430, and Sirna/RPI 30063/30224 constructs retain significant RNAi activity compared to the unmodified control siNA construct. It should be noted that Sirna/RPI 30433/30430 is a siNA construct having no ribonucleotides which retains significant RNAi activity compared to the unmodified control siGL2 construct in vitro, therefore, this construct is expected to have both similar RNAi activity and improved stability in vivo compared to siNA constructs having ribonucleotides.

**Figure 12** shows the results of an RNAi activity screen of chemically modified siNA constructs. The screen compared various combinations of sense strand chemical modifications and antisense strand chemical modifications. These chemically modified siNAs were compared in the luciferase assay described herein at 1 nM and 10nM concentration using an all RNA siNA control (siGL2) having 3'-terminal dithymidine (TT) and its corresponding inverted control (Inv siGL2). The background level of luciferase expression in the HeLa cells is designated by the "cells" column. Sense and antisense strands of chemically modified siNA constructs are shown by Sirna/RPI number (sense

strand/antisense strand). Sequences corresponding to these Sirna/RPI numbers are shown in Table I. As shown in the figure, the chemically modified Sirna/RPI 30063/30224 and Sirna/RPI 30063/30430 constructs retain significant RNAi activity compared to the control siNA (siGL2) construct. In addition, the antisense strand alone (Sirna/RPI 30430) and an  
5 inverted control (Sirna/RPI 30227/30229), having matched chemistry to Sirna/RPI (30063/30224) were compared to the siNA duplexes described above. The antisense strand (Sirna/RPI 30430) alone provides far less inhibition compared to the siNA duplexes using this sequence.

**Figure 13** shows the results of an RNAi activity screen of chemically modified siNA  
10 constructs. The screen compared various combinations of sense strand chemical modifications and antisense strand chemical modifications. These chemically modified siNAs were compared in the luciferase assay described herein at 1 nM and 10nM concentration using an all RNA siNA control (siGL2) having 3'-terminal dithymidine (TT) and its corresponding inverted control (Inv siGL2). The background level of luciferase  
15 expression in the HeLa cells is designated by the "cells" column. Sense and antisense strands of chemically modified siNA constructs are shown by Sirna/RPI number (sense strand/antisense strand). Sequences corresponding to these Sirna/RPI numbers are shown in Table I. In addition, an inverted control (Sirna/RPI 30226/30229, having matched chemistry to Sirna/RPI 30222/30224) was compared to the siNA duplexes described above.  
20 As shown in the figure, the chemically modified Sirna/RPI 28251/30430, Sirna/RPI 28251/30224, and Sirna/RPI 30222/30224 constructs retain significant RNAi activity compared to the control siNA construct, and the chemically modified Sirna/RPI 28251/30430 construct demonstrates improved activity compared to the control siNA (siGL2) construct.

**Figure 14** shows the results of an RNAi activity screen of chemically modified siNA  
25 constructs including various 3'-terminal modified siNA constructs compared to an all RNA control siNA construct using a luciferase reporter system. These chemically modified siNAs were compared in the luciferase assay described herein at 1 nM and 10nM concentration using an all RNA siNA control (siGL2) having 3'-terminal dithymidine (TT)  
30 and its corresponding inverted control (Inv siGL2). The background level of luciferase expression in the HeLa cells is designated by the "cells" column. Sense and antisense strands of chemically modified siNA constructs are shown by Sirna/RPI number (sense

strand/antisense strand). Sequences corresponding to these Sirna/RPI numbers are shown in Table I. As shown in the figure, the chemically modified Sirna/RPI 30222/30546, 30222/30224, 30222/30551, 30222/30557 and 30222/30558 constructs retain significant RNAi activity compared to the control siNA construct.

5           **Figure 15** shows the results of an RNAi activity screen of chemically modified siNA constructs. The screen compared various combinations of sense strand chemistries compared to a fixed antisense strand chemistry. These chemically modified siNAs were compared in the luciferase assay described herein at 1 nM and 10nM concentration using an all RNA siNA control (siGL2) having 3'-terminal dithymidine (TT) and its  
10 corresponding inverted control (Inv siGL2). The background level of luciferase expression in the HeLa cells is designated by the "cells" column. Sense and antisense strands of chemically modified siNA constructs are shown by Sirna/RPI number (sense strand/antisense strand). Sequences corresponding to these Sirna/RPI numbers are shown in Table I. As shown in the figure, the chemically modified Sirna/RPI 30063/30430,  
15 30434/30430, and 30435/30430 constructs all demonstrate greater activity compared to the control siNA (siGL2) construct.

#### Example 6: RNAi activity titration

A titration assay was performed to determine the lower range of siNA concentration required for RNAi activity both in a control siNA construct consisting of all RNA  
20 nucleotides containing two thymidine nucleotide overhangs and a chemically modified siNA construct comprising five phosphorothioate internucleotide linkages in both the sense and antisense strands. The assay was performed as described above, however, the siNA constructs were diluted to final concentrations between 2.5 nM and 0.025 nM. Results are shown in **Figure 16**. As shown in **Figure 16**, the chemically modified siNA construct  
25 shows a very similar concentration dependent RNAi activity profile to the control siNA construct when compared to an inverted siNA sequence control.

#### Example 7: siNA design

siNA target sites were chosen by analyzing sequences of the target RNA and optionally prioritizing the target sites on the basis of folding (structure of any given  
30 sequence analyzed to determine siNA accessibility to the target), by using a library of siNA

molecules as described in Example 4, or alternately by using an *in vitro* siNA system as described in Example 9 herein. siNA molecules were designed that could bind each target and are optionally individually analyzed by computer folding to assess whether the siNA molecule can interact with the target sequence. Varying the length of the siNA molecules  
5 can be chosen to optimize activity. Generally, a sufficient number of complementary nucleotide bases are chosen to bind to, or otherwise interact with, the target RNA, but the degree of complementarity can be modulated to accommodate siNA duplexes or varying length or base composition. By using such methodologies, siNA molecules can be designed to target sites within any known RNA sequence, for example those RNA  
10 sequences corresponding to the any gene transcript.

Chemically modified siNA constructs are designed to provide nuclease stability for systemic administration *in vivo* and/or improved pharmacokinetic, localization, and delivery properties while preserving the ability to mediate RNAi activity. Chemical modifications as described herein are introduced synthetically using synthetic methods  
15 described herein and those generally known in the art. The synthetic siNA constructs are then assayed for nuclease stability in serum and/or cellular/tissue extracts (e.g., liver extracts). The synthetic siNA constructs are also tested in parallel for RNAi activity using an appropriate assay, such as a luciferase reporter assay as described herein or another suitable assay that can quantify RNAi activity. Synthetic siNA constructs that possess both  
20 nuclease stability and RNAi activity can be further modified and re-evaluated in stability and activity assays. The chemical modifications of the stabilized active siNA constructs can then be applied to any siNA sequence targeting any chosen RNA and used, for example, in target screening assays to pick lead siNA compounds for therapeutic development (see for example **Figure 27**).

25 Example 8: Chemical Synthesis and Purification of siNA

siNA molecules can be designed to interact with various sites in the RNA message, for example, target sequences within the RNA sequences described herein. The sequence of one strand of the siNA molecule(s) is complementary to the target site sequences described above. The siNA molecules can be chemically synthesized using methods  
30 described herein. Inactive siNA molecules that are used as control sequences can be synthesized by scrambling the sequence of the siNA molecules such that it is not

complementary to the target sequence. Generally, siNA constructs can be synthesized using solid phase oligonucleotide synthesis methods as described herein (see for example Usman *et al.*, US Patent Nos. 5,804,683; 5,831,071; 5,998,203; 6,117,657; 6,353,098; 6,362,323; 6,437,117; 6,469,158; Scaringe *et al.*, US Patent Nos. 6,111,086; 6,008,400; 5 6,111,086 all incorporated by reference herein in their entirety).

In a non-limiting example, RNA oligonucleotides are synthesized in a stepwise fashion using the phosphoramidite chemistry as is known in the art. Standard phosphoramidite chemistry involves the use of nucleosides comprising any of 5'-O-dimethoxytrityl, 2'-O-tert-butyl dimethylsilyl, 3'-O-2-Cyanoethyl  
10 N,N-diisopropylphosphoramidite groups, and exocyclic amine protecting groups (e.g., N6-benzoyl adenosine, N4 acetyl cytidine, and N2-isobutyryl guanosine). Alternately, 2'-O-Silyl Ethers can be used in conjunction with acid-labile 2'-O-orthoester protecting groups in the synthesis of RNA as described by Scaringe *supra*. Differing 2' chemistries can require different protecting groups, for example 2'-deoxy-2'-amino nucleosides can  
15 utilize N-phthaloyl protection as described by Usman *et al.*, US Patent 5,631,360, incorporated by reference herein in its entirety).

During solid phase synthesis, each nucleotide is added sequentially (3'- to 5'-direction) to the solid support-bound oligonucleotide. The first nucleoside at the 3'-end of the chain is covalently attached to a solid support (e.g., controlled pore glass or  
20 polystyrene) using various linkers. The nucleotide precursor, a ribonucleoside phosphoramidite, and activator are combined resulting in the coupling of the second nucleoside phosphoramidite onto the 5'-end of the first nucleoside. The support is then washed and any unreacted 5'-hydroxyl groups are capped with a capping reagent such as acetic anhydride to yield inactive 5'-acetyl moieties. The trivalent phosphorus linkage is  
25 then oxidized to a more stable phosphate linkage. At the end of the nucleotide addition cycle, the 5'-O-protecting group is cleaved under suitable conditions (e.g., acidic conditions for trityl-based groups and Fluoride for silyl-based groups). The cycle is repeated for each subsequent nucleotide.

Modification of synthesis conditions can be used to optimize coupling efficiency, for  
30 example by using differing coupling times, differing reagent/phosphoramidite concentrations, differing contact times, differing solid supports and solid support linker



chemistries depending on the particular chemical composition of the siNA to be synthesized. Deprotection and purification of the siNA can be performed as is generally described in Deprotection and purification of the siNA can be performed as is generally described in Usman *et al.*, US 5,831,071, US 6,353,098, US 6,437,117, and Bellon *et al.*,  
5 US 6,054,576, US 6,162,909, US 6,303,773, or Scaringe *supra*, incorporated by reference herein in their entireties. Additionally, deprotection conditions can be modified to provide the best possible yield and purity of siNA constructs. For example, applicant has observed that oligonucleotides comprising 2'-deoxy-2'-fluoro nucleotides can degrade under inappropriate deprotection conditions. Such oligonucleotides are deprotected using  
10 aqueous methylamine at about 35°C for 30 minutes. If the 2'-deoxy-2'-fluoro containing oligonucleotide also comprises ribonucleotides, after deprotection with aqueous methylamine at about 35°C for 30 minutes, TEA-HF is added and the reaction maintained at about 65°C for an additional 15 minutes.

Example 9: RNAi *in vitro* assay to assess siNA activity

15 An *in vitro* assay that recapitulates RNAi in a cell free system is used to evaluate siNA constructs specific to target RNA. The assay comprises the system described by Tuschl *et al.*, 1999, *Genes and Development*, 13, 3191-3197 and Zamore *et al.*, 2000, *Cell*, 101, 25-33 adapted for use with target RNA. A *Drosophila* extract derived from syncytial blastoderm is used to reconstitute RNAi activity *in vitro*. Target RNA is generated via  
20 *in vitro* transcription from an appropriate plasmid using T7 RNA polymerase or via chemical synthesis as described herein. Sense and antisense siNA strands (for example 20 uM each) are annealed by incubation in buffer (such as 100 mM potassium acetate, 30 mM HEPES-KOH, pH 7.4, 2 mM magnesium acetate) for 1 minute at 90°C followed by 1 hour at 37°C, then diluted in lysis buffer (for example 100 mM potassium acetate, 30 mM  
25 HEPES-KOH at pH 7.4, 2mM magnesium acetate). Annealing can be monitored by gel electrophoresis on an agarose gel in TBE buffer and stained with ethidium bromide. The *Drosophila* lysate is prepared using zero to two-hour-old embryos from Oregon R flies collected on yeasted molasses agar that are dechorionated and lysed. The lysate is centrifuged and the supernatant isolated. The assay comprises a reaction mixture  
30 containing 50% lysate [vol/vol], RNA (10-50 pM final concentration), and 10% [vol/vol] lysis buffer containing siNA (10 nM final concentration). The reaction mixture also contains 10 mM creatine phosphate, 10 ug.ml creatine phosphokinase, 100 um GTP, 100

uM UTP, 100 uM CTP, 500 uM ATP, 5 mM DTT, 0.1 U/uL RNasin (Promega), and 100 uM of each amino acid. The final concentration of potassium acetate is adjusted to 100 mM. The reactions are pre-assembled on ice and preincubated at 25° C for 10 minutes before adding RNA, then incubated at 25° C for an additional 60 minutes. Reactions are quenched  
5 with 4 volumes of 1.25 x Passive Lysis Buffer (Promega). Target RNA cleavage is assayed by RT-PCR analysis or other methods known in the art and are compared to control reactions in which siNA is omitted from the reaction.

Alternately, internally-labeled target RNA for the assay is prepared by *in vitro* transcription in the presence of [ $\alpha$ -<sup>32</sup>P] CTP, passed over a G 50 Sephadex column by  
10 spin chromatography and used as target RNA without further purification. Optionally, target RNA is 5'-<sup>32</sup>P-end labeled using T4 polynucleotide kinase enzyme. Assays are performed as described above and target RNA and the specific RNA cleavage products generated by RNAi are visualized on an autoradiograph of a gel. The percentage of cleavage is determined by Phosphor Imager<sup>®</sup> quantitation of bands representing intact  
15 control RNA or RNA from control reactions without siNA and the cleavage products generated by the assay.

In one embodiment, this assay is used to determine target sites the RNA target for siNA mediated RNAi cleavage, wherein a plurality of siNA constructs are screened for RNAi mediated cleavage of the RNA target, for example, by analyzing the assay reaction  
20 by electrophoresis of labeled target RNA, or by northern blotting, as well as by other methodology well known in the art.

#### Example 10: Nucleic acid inhibition of target RNA *in vivo*

siNA molecules targeted to the target RNA are designed and synthesized as described above. These nucleic acid molecules can be tested for cleavage activity *in vivo*,  
25 for example, using the following procedure.

Two formats are used to test the efficacy of siNAs targeting a particular gene transcript. First, the reagents are tested on target expressing cells (e.g., HeLa), to determine the extent of RNA and protein inhibition. siNA reagents are selected against the RNA target. RNA inhibition is measured after delivery of these reagents by a suitable  
30 transfection agent to cells. Relative amounts of target RNA are measured versus actin

using real-time PCR monitoring of amplification (eg., ABI 7700 Taqman()). A comparison is made to a mixture of oligonucleotide sequences made to unrelated targets or to a randomized siNA control with the same overall length and chemistry, but with randomly substituted nucleotides at each position. Primary and secondary lead reagents are chosen for the target and optimization performed. 5 After an optimal transfection agent concentration is chosen, a RNA time-course of inhibition is performed with the lead siNA molecule. In addition, a cell-plating format can be used to determine RNA inhibition.

#### Delivery of siNA to Cells

10 Cells (e.g., HeLa) are seeded, for example, at  $1 \times 10^5$  cells per well of a six-well dish in EGM-2 (BioWhittaker) the day before transfection. siNA (final concentration, for example 20nM) and cationic lipid (e.g., final concentration  $2 \mu\text{g/ml}$ ) are complexed in EGM basal media (Biowhittaker) at  $37^\circ\text{C}$  for 30 mins in polystyrene tubes. Following vortexing, the complexed siNA is added to each well and incubated for the times indicated. 15 For initial optimization experiments, cells are seeded, for example, at  $1 \times 10^3$  in 96 well plates and siNA complex added as described. Efficiency of delivery of siNA to cells is determined using a fluorescent siNA complexed with lipid. Cells in 6-well dishes are incubated with siNA for 24 hours, rinsed with PBS and fixed in 2% paraformaldehyde for 15 minutes at room temperature. Uptake of siNA is visualized using a fluorescent 20 microscope.

#### Taqman and Lightcycler quantification of mRNA

Total RNA is prepared from cells following siNA delivery, for example, using Qiagen RNA purification kits for 6-well or Rneasy extraction kits for 96-well assays. For Taqman analysis, dual-labeled probes are synthesized with the reporter dye, FAM or JOE, 25 covalently linked at the 5'-end and the quencher dye TAMRA conjugated to the 3'-end. One-step RT-PCR amplifications are performed on, for example, an ABI PRISM 7700 Sequence Detector using 50  $\mu\text{l}$  reactions consisting of 10  $\mu\text{l}$  total RNA, 100 nM forward primer, 900 nM reverse primer, 100 nM probe, 1X TaqMan PCR reaction buffer (PE-Applied Biosystems), 5.5 mM  $\text{MgCl}_2$ , 300  $\mu\text{M}$  each dATP, dCTP, dGTP, and dTTP, 30 10U RNase Inhibitor (Promega), 1.25U AmpliTaq Gold (PE-Applied Biosystems) and 10U

M-MLV Reverse Transcriptase (Promega). The thermal cycling conditions can consist of 30 min at 48°C, 10 min at 95°C, followed by 40 cycles of 15 sec at 95°C and 1 min at 60°C. Quantitation of mRNA levels is determined relative to standards generated from serially diluted total cellular RNA (300, 100, 33, 11 ng/rxn) and normalizing to  $\beta$ -actin or GAPDH mRNA in parallel TaqMan reactions. For each gene of interest an upper and lower primer and a fluorescently labeled probe are designed. Real time incorporation of SYBR Green I dye into a specific PCR product can be measured in glass capillary tubes using a lightcycler. A standard curve is generated for each primer pair using control cRNA. Values are represented as relative expression to GAPDH in each sample.

#### 10 Western blotting

Nuclear extracts can be prepared using a standard micro preparation technique (see for example Andrews and Faller, 1991, *Nucleic Acids Research*, 19, 2499). Protein extracts from supernatants are prepared, for example using TCA precipitation. An equal volume of 20% TCA is added to the cell supernatant, incubated on ice for 1 hour and pelleted by centrifugation for 5 minutes. Pellets are washed in acetone, dried and resuspended in water. Cellular protein extracts are run on a 10% Bis-Tris NuPage (nuclear extracts) or 4-12% Tris-Glycine (supernatant extracts) polyacrylamide gel and transferred onto nitro-cellulose membranes. Non-specific binding can be blocked by incubation, for example, with 5% non-fat milk for 1 hour followed by primary antibody for 16 hour at 40C. Following washes, the secondary antibody is applied, for example (1:10,000 dilution) for 1 hour at room temperature and the signal detected with SuperSignal reagent (Pierce).

#### Example 11: Animal Models

Various animal models can be used to screen siNA constructs in vivo as are known in the art, for example those animal models that are used to evaluate other nucleic acid technologies such as enzymatic nucleic acid molecules (ribozymes) and/or antisense. Such animal models are used to test the efficacy of siNA molecules described herein. In a non-limiting example, siNA molecules that are designed as anti-angiogenic agents can be screened using animal models. There are several animal models available in which to test the anti-angiogenesis effect of nucleic acids of the present invention, such as siNA, directed against genes

associated with angiogenesis and/or metastasis, such as VEGFR (e.g., VEGFR1, VEGFR2, and VEGFR3) genes. Typically a corneal model has been used to study angiogenesis in rat and rabbit, since recruitment of vessels can easily be followed in this normally avascular tissue (Pandey et al., 1995 *Science* 268: 567-569). In these models, a small Teflon or Hydron disk pretreated with an angiogenesis factor (e.g., bFGF or VEGF) is inserted into a pocket surgically created in the cornea. Angiogenesis is monitored 3 to 5 days later. siNA molecules directed against VEGFR mRNAs would be delivered in the disk as well, or dropwise to the eye over the time course of the experiment. In another eye model, hypoxia has been shown to cause both increased expression of VEGF and neovascularization in the retina (Pierce et al., 1995 *Proc. Natl. Acad. Sci. USA.* 92: 905-909; Shweiki et al., 1992 *J. Clin. Invest.* 91: 2235-2243).

Several animal models exist for screening of anti-angiogenic agents. These include corneal vessel formation following corneal injury (Burger et al., 1985 *Cornea* 4: 35-41; Lepri, et al., 1994 *J. Ocular Pharmacol.* 10: 273-280; Ormerod et al., 1990 *Am. J. Pathol.* 137: 1243-1252) or intracorneal growth factor implant (Grant et al., 1993 *Diabetologia* 36: 282-291; Pandey et al. 1995 *supra*; Zieche et al., 1992 *Lab. Invest.* 67: 711-715), vessel growth into Matrigel matrix containing growth factors (Passaniti et al., 1992 *supra*), female reproductive organ neovascularization following hormonal manipulation (Shweiki et al., 1993 *Clin. Invest.* 91: 2235-2243), several models involving inhibition of tumor growth in highly vascularized solid tumors (O'Reilly et al., 1994 *Cell* 79: 315-328; Senger et al., 1993 *Cancer and Metas. Rev.* 12: 303-324; Takahasi et al., 1994 *Cancer Res.* 54: 4233-4237; Kim et al., 1993 *supra*), and transient hypoxia-induced neovascularization in the mouse retina (Pierce et al., 1995 *Proc. Natl. Acad. Sci. USA.* 92: 905-909).gene

The cornea model, described in Pandey et al. *supra*, is the most common and well characterized anti-angiogenic agent efficacy screening model. This model involves an avascular tissue into which vessels are recruited by a stimulating agent (growth factor, thermal or alkali burn, endotoxin). The corneal model utilizes the intrastromal corneal implantation of a Teflon pellet soaked in a VEGF-Hydron solution to recruit blood vessels toward the pellet, which can be quantitated using standard microscopic and image analysis techniques. To evaluate their anti-angiogenic efficacy, siNA molecules are applied

topically to the eye or bound within Hydron on the Teflon pellet itself. This avascular cornea as well as the Matrigel model (described below) provide for low background assays. While the corneal model has been performed extensively in the rabbit, studies in the rat have also been conducted.

5           The mouse model (Passaniti et al., *supra*) is a non-tissue model which utilizes Matrigel, an extract of basement membrane (Kleinman et al., 1986) or Millipore® filter disk, which can be impregnated with growth factors and anti-angiogenic agents in a liquid form prior to injection. Upon subcutaneous administration at body temperature, the Matrigel or Millipore® filter disk forms a solid implant. VEGF embedded in the Matrigel  
10 or Millipore® filter disk is used to recruit vessels within the matrix of the Matrigel or Millipore® filter disk which can be processed histologically for endothelial cell specific vWF (factor VIII antigen) immunohistochemistry, Trichrome-Masson stain, or hemoglobin content. Like the cornea, the Matrigel or Millipore® filter disk are avascular; however, it is not tissue. In the Matrigel or Millipore® filter disk model, siNA molecules  
15 are administered within the matrix of the Matrigel or Millipore® filter disk to test their anti-angiogenic efficacy. Thus, delivery issues in this model, as with delivery of siNA molecules by Hydron- coated Teflon pellets in the rat cornea model, may be less problematic due to the homogeneous presence of the siNA within the respective matrix.

          The Lewis lung carcinoma and B-16 murine melanoma models are well accepted  
20 models of primary and metastatic cancer and are used for initial screening of anti-cancer agents. These murine models are not dependent upon the use of immunodeficient mice, are relatively inexpensive, and minimize housing concerns. Both the Lewis lung and B-16 melanoma models involve subcutaneous implantation of approximately  $10^6$  tumor cells from metastatically aggressive tumor cell lines (Lewis lung lines 3LL or D122, LLc-LN7;  
25 B-16-BL6 melanoma) in C57BL/6J mice. Alternatively, the Lewis lung model can be produced by the surgical implantation of tumor spheres (approximately 0.8 mm in diameter). Metastasis also may be modeled by injecting the tumor cells directly intravenously. In the Lewis lung model, microscopic metastases can be observed approximately 14 days following implantation with quantifiable macroscopic metastatic  
30 tumors developing within 21-25 days. The B-16 melanoma exhibits a similar time course with tumor neovascularization beginning 4 days following implantation. Since both

primary and metastatic tumors exist in these models after 21-25 days in the same animal, multiple measurements can be taken as indices of efficacy. Primary tumor volume and growth latency as well as the number of micro- and macroscopic metastatic lung foci or number of animals exhibiting metastases can be quantitated. The percent increase in  
5 lifespan can also be measured. Thus, these models would provide suitable primary efficacy assays for screening systemically administered siNA molecules and siNA formulations.

In the Lewis lung and B-16 melanoma models, systemic pharmacotherapy with a wide variety of agents usually begins 1-7 days following tumor implantation/inoculation with either continuous or multiple administration regimens. Concurrent pharmacokinetic  
10 studies can be performed to determine whether sufficient tissue levels of siNA can be achieved for pharmacodynamic effect to be expected. Furthermore, primary tumors and secondary lung metastases can be removed and subjected to a variety of *in vitro* studies (*i.e.* target RNA reduction).

Ohno-Matsui *et al.*, 2002, *Am. J. Pathology*, 160, 711-719 describe a model of severe  
15 proliferative retinopathy and retinal detachment in mice under inducible expression of vascular endothelial growth factor. In this model, expression of a VEGF transgene results in elevated levels of ocular VEGF that is associated with severe proliferative retinopathy and retinal detachment. Furthermore, Mori *et al.*, 2001, *J. Cellular Physiology*, 188, 253-263, describe a model of laser induced choroidal neovascularization that can be used in  
20 conjunction with intravitreal or subretinal injection of siNA molecules of the invention to evaluate the efficacy of siNA treatment of severe proliferative retinopathy and retinal detachment.

In utilizing these models to assess siNA activity, VEGFR1, VEGFR2, and/or VEGFR3 protein levels can be measured clinically or experimentally by FACS analysis.  
25 VEGFR1, VEGFR2, and/or VEGFR3 encoded mRNA levels can be assessed by Northern analysis, RNase-protection, primer extension analysis and/or quantitative RT-PCR. siNA molecules that block VEGFR1, VEGFR2, and/or VEGFR3 protein encoding mRNAs and therefore result in decreased levels of VEGFR1, VEGFR2, and/or VEGFR3 activity by more than 20% *in vitro* can be identified using the techniques described herein.

Example 12: siNA-mediated inhibition of angiogenesis *in vivo*

The purpose of this study was to assess the anti-angiogenic activity of siNA targeted against VEGFR1, using the rat cornea model of VEGF induced angiogenesis discussed in Example 11 above). The siNA molecules shown in **Figure 23** have matched inverted controls which are inactive since they are not able to interact with the RNA target. The siNA molecules and VEGF were co-delivered using the filter disk method. Nitrocellulose filter disks (Millipore®) of 0.057 diameter were immersed in appropriate solutions and were surgically implanted in rat cornea as described by Pandey *et al.*, *supra*.

The stimulus for angiogenesis in this study was the treatment of the filter disk with 30  $\mu$ M VEGF which is implanted within the cornea's stroma. This dose yields reproducible neovascularization stemming from the pericorneal vascular plexus growing toward the disk in a dose-response study 5 days following implant. Filter disks treated only with the vehicle for VEGF show no angiogenic response. The siNA were co-administered with VEGF on a disk in three different siNA concentrations. One concern with the simultaneous administration is that the siNA would not be able to inhibit angiogenesis since VEGF receptors can be stimulated. However, Applicant has observed that in low VEGF doses, the neovascular response reverts to normal suggesting that the VEGF stimulus is essential for maintaining the angiogenic response. Blocking the production of VEGF receptors using simultaneous administration of anti-VEGF-R mRNA siNA could attenuate the normal neovascularization induced by the filter disk treated with VEGF.

Materials and Methods:Test Compounds and Controls

R&D Systems VEGF, carrier free at 75  $\mu$ M in 82 mM Tris-Cl, pH 6.9  
siNA, 1.67  $\mu$ G/ $\mu$ L, SITE 2340 (SIRNA/RPI 29695/29699) sense/antisense  
siNA, 1.67  $\mu$ G/ $\mu$ L, INVERTED CONTROL FOR SITE 2340 (SIRNA/RPI 29983/29984) sense/antisense  
siNA 1.67  $\mu$ g/ $\mu$ L, Site 2340 (Sirna/RPI 30196/30416) sense/antisense



*Animals*

Harlan Sprague-Dawley Rats, Approximately 225-250g

45 males, 5 animals per group.

5 *Husbandry*

Animals are housed in groups of two. Feed, water, temperature and humidity are determined according to Pharmacology Testing Facility performance standards (SOP's) which are in accordance with the 1996 Guide for the Care and Use of Laboratory Animals  
10 (NRC). Animals are acclimated to the facility for at least 7 days prior to experimentation. During this time, animals are observed for overall health and sentinels are bled for baseline serology.

*Experimental Groups*

15 Each solution (VEGF and siNAs) was prepared as a 1X solution for final concentrations shown in the experimental groups described in **Table III**.

*siNA Annealing Conditions*

siNA sense and antisense strands are annealed for 1 minute in H<sub>2</sub>O at  
20 1.67mg/mL/strand followed by a 1 hour incubation at 37°C producing 3.34 mg/mL of duplexed siNA. For the 20µg/eye treatment, 6 µLs of the 3.34 mg/mL duplex is injected into the eye (see below). The 3.34 mg/mL duplex siNA can then be serially diluted for dose response assays.

25 *Preparation of VEGF Filter Disk*

For corneal implantation, 0.57 mm diameter nitrocellulose disks, prepared from 0.45 µm pore diameter nitrocellulose filter membranes (Millipore Corporation), were soaked for 30 min in 1 µL of 75 µM VEGF in 82 mM Tris·HCl (pH 6.9) in covered petri dishes on ice.

Filter disks soaked only with the vehicle for VEGF (83 mM Tris-Cl pH 6.9) elicit no angiogenic response.

#### *Corneal surgery*

5           The rat corneal model used in this study was a modified from Koch *et al. Supra* and Pandey *et al., supra*. Briefly, corneas were irrigated with 0.5% povidone iodine solution followed by normal saline and two drops of 2% lidocaine. Under a dissecting microscope (Leica MZ-6), a stromal pocket was created and a presoaked filter disk (see above) was inserted into the pocket such that its edge was 1 mm from the corneal limbus.

#### 10    *Intraconjunctival injection of test solutions*

          Immediately after disk insertion, the tip of a 40-50  $\mu\text{m}$  OD injector (constructed in our laboratory) was inserted within the conjunctival tissue 1 mm away from the edge of the corneal limbus that was directly adjacent to the VEGF-soaked filter disk. Six hundred  
15   nanoliters of test solution (siNA, inverted control or sterile water vehicle) were dispensed at a rate of 1.2  $\mu\text{L}/\text{min}$  using a syringe pump (Kd Scientific). The injector was then removed, serially rinsed in 70% ethanol and sterile water and immersed in sterile water  
20   between each injection. Once the test solution was injected, closure of the eyelid was maintained using microaneurism clips until the animal began to recover gross motor activity. Following treatment, animals were warmed on a heating pad at 37°C.

#### *Quantitation of angiogenic response*

          Five days after disk implantation, animals were euthanized following administration of 0.4 mg/kg atropine and corneas were digitally imaged. The neovascular surface area  
25   (NSA, expressed in pixels) was measured *postmortem* from blood-filled corneal vessels using computerized morphometry (Image Pro Plus, Media Cybernetics, v2.0). The individual mean NSA was determined in triplicate from three regions of identical size in the area of maximal neovascularization between the filter disk and the limbus. The number of pixels corresponding to the blood-filled corneal vessels in these regions was summated  
30   to produce an index of NSA. A group mean NSA was then calculated. Data from each

treatment group were normalized to VEGF/siNA vehicle-treated control NSA and finally expressed as percent inhibition of VEGF-induced angiogenesis.

### *Statistics*

- 5           After determining the normality of treatment group means, group mean percent inhibition of VEGF-induced angiogenesis was subjected to a one-way analysis of variance. This was followed by two post-hoc tests for significance including Dunnett's (comparison to VEGF control) and Tukey-Kramer (all other group mean comparisons) at alpha = 0.05. Statistical analyses were performed using JMP v.3.1.6 (SAS Institute).
- 10           Results of the study are graphically represented in **Figures 23 and 76**. As shown in **Figure 23**, VEGFr1 site 4229 active siNA (Sirna/RPI 29695/29699) at three concentrations were effective at inhibiting angiogenesis compared to the inverted siNA control (Sirna/RPI 29983/29984) and the VEGF control. A chemically modified version of the VEGFr1 site
- 15           ribo purines with 5' and 3' terminal inverted deoxyabasic residues and an antisense strand having having 2'-deoxy-2'-fluoro pyrimidines and ribo purines with a terminal 3'-phosphorothioate internucleotide linkage (Sirna/RPI 30196/30416), showed similar inhibition. Furthermore, VEGFr1 site 349 active siNA having "Stab 9/10" chemistry (Sirna # 31270/31273) was tested for inhibition of VEGF-induced angiogenesis at three
- 20           different concentrations (2.0 ug, 1.0 ug, and 0.1  $\mu$ g dose response) as compared to a matched chemistry inverted control siNA construct (Sirna # 31276/31279) at each concentration and a VEGF control in which no siNA was administered. As shown in **Figure 76**, the active siNA construct having "Stab 9/10" chemistry (Sirna # 31270/31273) is highly effective in inhibiting VEGF-induced angiogenesis in the rat corneal model
- 25           compared to the matched chemistry inverted control siNA at concentrations from 0.1  $\mu$ g to 2.0 ug. These results demonstrate that siNA molecules having different chemically modified compositions, such as the modifications described herein, are capable of significantly inhibiting angiogenesis *in vivo*.

Example 13: Inhibition of HBV using siNA Molecules of the Invention*Transfection of HepG2 Cells with psHBV-1 and siNA*

The human hepatocellular carcinoma cell line Hep G2 was grown in Dulbecco's modified Eagle media supplemented with 10% fetal calf serum, 2 mM glutamine, 0.1 mM  
5 nonessential amino acids, 1 mM sodium pyruvate, 25 mM Hepes, 100 units penicillin, and  
100 µg/ml streptomycin. To generate a replication competent cDNA, prior to transfection  
the HBV genomic sequences are excised from the bacterial plasmid sequence contained in  
the psHBV-1 vector. Other methods known in the art can be used to generate a replication  
competent cDNA. This was done with an EcoRI and Hind III restriction digest. Following  
10 completion of the digest, a ligation was performed under dilute conditions (20 µg/ml) to  
favor intermolecular ligation. The total ligation mixture was then concentrated using  
Qiagen spin columns.

*siNA Activity Screen and Dose Response Assay*

Transfection of the human hepatocellular carcinoma cell line, Hep G2, with  
15 replication-competent HBV DNA results in the expression of HBV proteins and the  
production of virions. To test the efficacy of siNAs targeted against HBV RNA, several  
siNA duplexes targeting different sites within HBV pregenomic RNA were co-transfected  
with HBV genomic DNA once at 25 nM with lipid at 12.5 µg/ml into Hep G2 cells, and the  
subsequent levels of secreted HBV surface antigen (HBsAg) were analyzed by ELISA (see  
20 **Figure 24**). Inverted sequence duplexes were used as negative controls. Subsequently,  
dose response studies were performed in which the siNA duplexes were co-transfected with  
HBV genomic DNA at 0.5, 5, 10 and 25 nM with lipid at 12.5 µg/ml into Hep G2 cells, and  
the subsequent levels of secreted HBV surface antigen (HBsAg) were analyzed by ELISA  
(see **Figure 25**).

*25 Analysis of HBsAg Levels Following siNA Treatment*

To determine siNA activity, HbsAg levels were measured following transfection  
with siNA. Immulon 4 (Dynax) microtiter wells were coated overnight at 4( C with  
anti-HBsAg Mab (Biostride B88-95-31ad,ay) at 1 (g/ml in Carbonate Buffer (Na<sub>2</sub>CO<sub>3</sub> 15  
mM, NaHCO<sub>3</sub> 35 mM, pH 9.5). The wells were then washed 4x with PBST (PBS, 0.05%

Tween® 20) and blocked for 1 hr at 37( C with PBST, 1% BSA. Following washing as above, the wells were dried at 37( C for 30 min. Biotinylated goat anti-HBsAg (Accurate YVS1807) was diluted 1:1000 in PBST and incubated in the wells for 1 hr. at 37( C. The wells were washed 4x with PBST. Streptavidin/Alkaline Phosphatase Conjugate (Pierce 21324) was diluted to 250 ng/ml in PBST, and incubated in the wells for 1 hr. at 37( C. After washing as above, p-nitrophenyl phosphate substrate (Pierce 37620) was added to the wells, which were then incubated for 1 hour at 37( C. The optical density at 405 nm was then determined. Results of the HBV screen study are summarized in Figure 24, whereas the results of a dose response assay using lead siNA constructs targeting sites 262 and 1580 of the HBV pregenomic RNA are shown in Figure 25. As shown in Figure 25, the siNA constructs targeting sites 262 and 1580 of HBV RNA provides significant dose response inhibition of viral replication/activity when compared to inverted siNA controls.

Comparison of different chemically stabilized siNA motifs targeting HBV RNA site 1580

Two different siNA stabilization chemistries were compared in a dose response HBsAg assay using inverted matched chemistry controls. The “Stab7/8” (Table IV) constructs comprise a sense strand having 2'-deoxy-2'-fluoro pyrimidine nucleotides and 2'-deoxy purine nucleotides with 5' and 3' terminal inverted deoxyabasic residues and an antisense strand having 2'-deoxy-2'-fluoro pyrimidine nucleotides and 2'-O-methyl purine nucleotides with a terminal 3' phosphorothioate linkage. The “Stab7/11 (Table IV) constructs comprise a sense strand having 2'-deoxy-2'-fluoro pyrimidine nucleotides and 2'-deoxy purine nucleotides with 5' and 3' terminal inverted deoxyabasic residues and an antisense strand having 2'-deoxy-2'-fluoro pyrimidine nucleotides and 2'-deoxy purine nucleotides with a terminal 3' phosphorothioate linkage (see for example Table I). As shown in Figure 26, the chemically stabilized siNA constructs both show significant inhibition of HBV antigen in a dose dependent manner compared to matched inverted controls. A separate direct screen of Stab 7/8 constructs targeting HBV RNA in HepG2 cells that identified stabilized siNA constructs with potent activity is shown in Figure 87.

Time course evaluation of different chemically stabilized siNA motifs targeting HBV RNA site 1580

Four different siNA constructs having different stabilization chemistries were compared to an unstabilized siRNA construct in a dose response time course HBsAg assay,

the results of which are shown in Figures 28-31. The different constructs were compared to an unstabilized ribonucleotide control siRNA construct (Sirna/RPI#30287/30298) at different concentrations (5nM, 10 nM, 25 nM, 50 nM, and 100 nM) over the course of nine days. Activity based on HBsAg levels was determined at day 3, day 6, and day 9. The “Stab 4/5” (Table IV) constructs comprise a sense strand (Sirna/RPI#30355) having 2'-deoxy-2'-fluoro pyrimidine nucleotides and purine ribonucleotides with 5' and 3' terminal inverted deoxybasic residues and an antisense strand (Sirna/RPI#30366) having 2'-deoxy-2'-fluoro pyrimidine nucleotides and purine ribonucleotides with a terminal 3' phosphorothioate linkage (data shown in Figure 28). The “Stab7/8” (Table IV) constructs comprise a sense strand (Sirna/RPI#30612) having 2'-deoxy-2'-fluoro pyrimidine nucleotides and 2'-deoxy purine nucleotides with 5' and 3' terminal inverted deoxybasic residues and an antisense strand (Sirna/RPI#30620) having 2'-deoxy-2'-fluoro pyrimidine nucleotides and 2'-O-methyl purine nucleotides with a terminal 3' phosphorothioate linkage (data shown in Figure 29). The “Stab7/11 (Table IV) constructs comprise a sense (Sirna/RPI#30612) strand having 2'-deoxy-2'-fluoro pyrimidine nucleotides and 2'-deoxy purine nucleotides with 5' and 3' terminal inverted deoxybasic residues and an antisense strand (Sirna/RPI#31175) having 2'-deoxy-2'-fluoro pyrimidine nucleotides and 2'-deoxy purine nucleotides with a terminal 3' phosphorothioate linkage (data shown in Figure 30). The “Stab9/10 (Table IV) constructs comprise a sense (Sirna/RPI#31335) strand having ribonucleotides with 5' and 3' terminal inverted deoxybasic residues and an antisense strand (Sirna/RPI#31337) having ribonucleotides with a terminal 3' phosphorothioate linkage (data shown in Figure 31). As shown in Figures 28-31, the chemically stabilized siNA constructs all show significantly greater inhibition of HBV antigen in a dose dependent manner over the time course experiment compared to the unstabilized siRNA construct.

A second study was performed using the stab 4/5 (Sirna 30355/30366), stab 7/8 (Sirna 30612/30620), and stab 7/11 (Sirna 30612/31175) siNA constructs described above to examine the duration of effect of the modified siNA constructs out to 21 days post transfection compared to an all RNA control siNA (Sirna 30287/30298). A single transfection was performed with siRNAs targeted to HBV site 1580 and the culture media was subsequently replaced every three days. Secreted HBsAg levels were monitored for at 3, 6, 9, 12, 15, 18 and 21 days post-transfection. Figure 77 shows activity of siNAs in

reduction of HBsAg levels compared to matched inverted controls at A. 3 days, B. 9 days, and C. 21 days post transfection. Also shown is the corresponding percent inhibition as function of time at siNA concentrations of D. 100 nM, E. 50 nM, and F. 25 nM.

Example 14: Inhibition of HCV using siNA Molecules of the Invention

5 siNA Inhibition of a chimeric HCV/Poliovirus in HeLa Cells

Inhibition of a chimeric HCV/Poliovirus was investigated using 21 nucleotide siNA duplexes in HeLa cells. Seven siNA constructs were designed that target three regions in the highly conserved 5' untranslated region (UTR) of HCV RNA. The siNAs were screened in two cell culture systems dependent upon the 5'-UTR of HCV; one requires translation of an HCV/luciferase gene, while the other involves replication of a chimeric HCV/poliovirus (PV) (see Blatt et al., USSN 09/740,332, filed December 18, 2000, incorporated by reference herein). Two siNAs (29579/29586; 29578/29585) targeting the same region (shifted by one nucleotide) are active in both systems (see Figure 32) as compared with inverse control siNA (29593/29600). For example, a >85% reduction in HCVPV replication was observed in siNA-treated cells compared to an inverse siNA control (Figure 32) with an IC50 = ~2.5 nM (Figure 33). To develop nuclease-resistant siNA for in vivo applications, siNAs can be modified to contain stabilizing chemical modifications. Such modifications include phosphorothioate linkages (P=S), 2'-O-methyl nucleotides, 2'-fluoro (F) nucleotides, 2'-deoxy nucleotides, universal base nucleotides, 5' and/or 3' end modifications and a variety of other nucleotide and non-nucleotide modifications, in one or both siNA strands. Several of these constructs were tested in the HCV/poliovirus chimera system, demonstrating significant reduction in viral replication (Figures 34-37). siNA constructs shown in Figures 34-37 are referred to by Sirna/RPI#s that are cross referenced to Table III, which shows the sequence and chemical modifications of the constructs. siNA activity is compared to relevant controls (untreated cells, scrambled/inactive control sequences, or transfection controls). As shown in the Figures, siNA constructs of the invention provide potent inhibition of HCV RNA in the HCV/poliovirus chimera system. As such, siNA constructs, including chemically modified, nuclease resistant siNA molecules, represent an important class of therapeutic agents for treating chronic HCV infection.

siNA Inhibition of a HCV RNA expression in a HCV replicon system

In addition, a HCV replicon system was used to test the efficacy of siNAs targeting HCV RNA. The reagents are tested in cell culture using Huh7 cells (see for example Randall et al., 2003, PNAS USA, 100, 235-240) to determine the extent of RNA and protein inhibition. siNA were selected against the HCV target as described herein. RNA inhibition was measured after delivery of these reagents by a suitable transfection agent to Huh7 cells. Relative amounts of target RNA are measured versus actin using real-time PCR monitoring of amplification (eg., ABI 7700 Taqman). A comparison is made to a mixture of oligonucleotide sequences designed to target unrelated targets or to a randomized siNA control with the same overall length and chemistry, but with randomly substituted nucleotides at each position. Primary and secondary lead reagents were chosen for the target and optimization performed. After an optimal transfection agent concentration is chosen, a RNA time-course of inhibition is performed with the lead siNA molecule. In addition, a cell-plating format can be used to determine RNA inhibition. A non-limiting example of a multiple target screen to assay siNA mediated inhibition of HCV RNA is shown in Figure 38. siNA reagents (Table I) were transfected at 25 nM into Huh7 cells and HCV RNA quantitated compared to untreated cells ("cells" column in the figure) and cells transfected with lipofectamine ("LFA2K" column in the figure). As shown in the Figure, several siNA constructs show significant inhibition of HCV RNA expression in the Huh7 replicon system. Chemically modified siNA constructs were then screened as described above, with a non-limiting example of a Stab 7/8 (see Table IV) chemistry siNA construct screen shown in Figure 40. A follow up dose response study using chemically modified siNA constructs (Stab 4/5, see Table IV) at concentrations of 5nM, 10nM, 25 nM and 100 nM compared to matched chemistry inverted controls is shown in Figure 39, whereas a dose response study for Stab 7/8 constructs at concentrations of 5nM, 10nM, 25 nM, 50 nM and 100 nM compared to matched chemistry inverted controls is shown in Figure 41. A separate direct screen of Stab 7/8 constructs targeting HCV RNA that identified stabilized siNA constructs with potent activity is shown in Figure 86.

Example 15: Target Discovery in Mammalian Cells using siNA molecules

In a non-limiting example, compositions and methods of the invention are used to discover genes involved in a process of interest within mammalian cells, such as cell



growth, proliferation, apoptosis, morphology, angiogenesis, differentiation, migration, viral multiplication, drug resistance, signal transduction, cell cycle regulation, or temperature sensitivity or other process. First, a randomized siNA library is generated. These constructs are inserted into a vector capable of expressing a siNA from the library  
5 inside mammalian cells. Alternately, a pool of synthetic siNA molecules is generated.

#### *Reporter System*

In order to discover genes playing a role in the expression of certain proteins, such as proteins involved in a cellular process described herein, a readily assayable reporter system is constructed in which a reporter molecule is co-expressed when a particular protein of  
10 interest is expressed. The reporter system consists of a plasmid construct bearing a gene coding for a reporter gene, such as Green Fluorescent Protein (GFP) or other reporter proteins known and readily available in the art. The promoter region of the GFP gene is replaced by a portion of a promoter for the protein of interest sufficient to direct efficient transcription of the GFP gene. The plasmid can also contain a drug resistance gene, such as  
15 neomycin resistance, in order to select cells containing the plasmid.

#### *Host Cell Lines for Target Discovery*

A cell line is selected as host for target discovery. The cell line is preferably known to express the protein of interest, such that upstream genes controlling the expression of the protein can be identified when modulated by a siNA construct expressed therein. The cells  
20 preferably retain protein expression characteristics in culture. The reporter plasmid is transfected into cells, for example, using a cationic lipid formulation. Following transfection, the cells are subjected to limiting dilution cloning, for example, under selection by 600 µg/mL Geneticin. Cells retaining the plasmid survive the Geneticin treatment and form colonies derived from single surviving cells. The resulting clonal cell  
25 lines are screened by flow cytometry for the capacity to upregulate GFP production. Treating the cells with, for example, sterilized M9 bacterial medium in which *Pseudomonas aeruginosa* had been cultured (Pseudomonas conditioned medium, PCM) is used to induce the promoter. The PCM is supplemented with phorbol myristate acetate (PMA). A clonal cell line highly responsive to promoter induction is selected as the  
30 reporter line for subsequent studies.

*siNA Library Construction*

A siNA library was constructed with oligonucleotides containing hairpin siNA constructs having randomized antisense regions and self complementary sense regions. The library is generated synthesizing siNA constructs having randomized sequence. Alternately, the siNA libraries are constructed as described in Usman *et al.*, USSN 5 60/402,996 (incorporated by reference herein) Oligo sequence 5' and 3' of the siNA contains restriction endonuclease cleavage sites for cloning. The 3' trailing sequence forms a stem-loop for priming DNA polymerase extension to form a hairpin structure. The hairpin DNA construct is melted at 90°C allowing DNA polymerase to generate a dsDNA 10 construct. The double-stranded siNA library is cloned into, for example, a U6+27 transcription unit located in the 5' LTR region of a retroviral vector containing the human nerve growth factor receptor (hNGFr) reporter gene. Positioning the U6+27/siNA transcription unit in the 5' LTR results in a duplication of the transcription unit when the vector integrates into the host cell genome. As a result, the siNA is transcribed by RNA 15 polymerase III from U6+27 and by RNA polymerase II activity directed by the 5' LTR. The siNA library is packaged into retroviral particles that are used to infect and transduce clonal cells selected above. Assays of the hNGFr reporter are used to indicate the percentage of cells that incorporated the siNA construct. By randomized region is meant a region of completely random sequence and/or partially random sequence. By completely 20 random sequence is meant a sequence wherein theoretically there is equal representation of A, T, G and C nucleotides or modified derivatives thereof, at each position in the sequence. By partially random sequence is meant a sequence wherein there is an unequal representation of A, T, G and C nucleotides or modified derivatives thereof, at each position in the sequence. A partially random sequence can therefore have one or more 25 positions of complete randomness and one or more positions with defined nucleotides.

*Enriching for Non-responders to Induction*

Sorting of siNA library-containing cells is performed to enrich for cells that produce less reporter GFP after treatment with the promoter inducers PCM and PMA. Lower GFP production can be due to RNAi activity against genes involved in the activation of the 30 mucin promoter. Alternatively, siNA can directly target the mucin/GFP transcript resulting in reduced GFP expression.

Cells are seeded at a certain density, such as  $1 \times 10^6$  per  $150 \text{ cm}^2$  style cell culture flasks and grown in the appropriate cell culture medium with fetal bovine serum. After 72 hours, the cell culture medium is replaced with serum-free medium. After 24 hours of serum deprivation, the cells are treated with serum-containing medium supplemented with PCM (to 40%) and PMA (to 50 nM) to induced GFP production. After 20 to 22 hours, cells are monitored for GFP level on, for example, a FACStar Plus cell sorter. Sorting is performed if  $\geq 90\%$  of siNA library cells from an unsorted control sample were induced to produce GFP above background levels. Two cell fractions are collected in each round of sorting. Following the appropriate round of sorting, the M1 fraction is selected to generate a database of siNA molecules present in the sorted cells.

#### *Recovery of siNA Sequence from Sorted Cells*

Genomic DNA is obtained from sorted siNA library cells by standard methods. Nested polymerase chain reaction (PCR) primers that hybridized to the retroviral vector 5' and 3' of the siNA are used to recover and amplify the siNA sequences from the particular clone of library cell DNA. The PCR product is ligated into a bacterial cloning vector. The recovered siNA library in plasmid form can be used to generate a database of siNA sequences. For example, the library is cloned into *E. coli*. DNA is prepared by plasmid isolation from bacterial colonies or by direct colony PCR and siNA sequence is determined. A second method can use the siNA library to transfect cloned cells. Clonal lines of stably transfected cells are established and induced with, for example, PCM and PMA. Those lines which fail to respond to GFP induction are probed by PCR for single siNA integration events. The unique siNA sequences obtained by both methods are added to a Target Sequence Tag (TST) database.

#### *Bioinformatics*

The antisense region sequences of the isolated siNA constructs are compared to public and private gene data banks. Gene matches are compiled according to perfect and imperfect matches. Potential gene targets are categorized by the number of different siNA sequences matching each gene. Genes with more than one perfect siNA match are selected for Target Validation studies.

*Validation of the Target Gene*

To validate a target as a regulator of protein expression, siNA reagents are designed to the target gene cDNA sequence from Genbank. The siNA reagents are complexed with a cationic lipid formulation prior to administration to cloned cells at appropriate concentrations (e.g., 5-50 nM or less). Cells are treated with siNA reagents, for example from 72 to 96 hours. Before the termination of siNA treatment, PCM (to 40 %) and PMA (to 50 nM), for example, are added to induce the promoter. After twenty hours of induction the cells are harvested and assayed for phenotypic and molecular parameters. Reduced GFP expression in siNA treated cells (measured by flow cytometry) is taken as evidence for validation of the target gene. Knockdown of target RNA in siNA treated cells can correlate with reduced endogenous RNA and reduced GFP RNA to complete validation of the target.

Example 16: Screening siNA constructs for improved pharmacokinetics

In a non-limiting example, siNA constructs are screened in vivo for improved pharmacokinetic properties compared to all RNA or unmodified siNA constructs. Chemical modifications are introduced into the siNA construct based on educated design parameters (e.g., introducing 2'-mofications, base modifications, backbone modifications, terminal cap modifications, or covalently attached conjugates etc). The modified construct is tested in an appropriate system (e.g human serum for nuclease resistance, shown, or an animal model for PK/delivery parameters). In parallel, the siNA construct is tested for RNAi activity, for example in a cell culture system such as a luciferase reporter assay). Lead siNA constructs are then identified which possess a particular characteristic while maintaining RNAi activity, and can be further modified and assayed once again. This same approach can be used to identify siNA-conjugate molecules with improved pharmacokinetic profiles, delivery, localized delivery, cellular uptake, and RNAi activity.

Example 17: Indications

The siNA molecules of the invention can be used to treat a variety of diseases and conditions through modulation of gene expression. Using the methods described herein, chemically modified siNA molecules can be designed to modulate the expression any number of target genes, including but not limited to genes associated with cancer,

metabolic diseases, infectious diseases such as viral, bacterial or fungal infections, neurologic diseases, musculoskeletal diseases, diseases of the immune system, diseases associated with signaling pathways and cellular messengers, and diseases associated with transport systems including molecular pumps and channels.

5 Non-limiting examples of various viral genes that can be targeted using siNA molecules of the invention include Hepatitis C Virus (HCV, for example Genbank Accession Nos: D11168, D50483.1, L38318 and S82227), Hepatitis B Virus (HBV, for example GenBank Accession No. AF100308.1), Human Immunodeficiency Virus type 1 (HIV-1, for example GenBank Accession No. U51188), Human Immunodeficiency Virus  
10 type 2 (HIV-2, for example GenBank Accession No. X60667), West Nile Virus (WNV for example GenBank accession No. NC\_001563), cytomegalovirus (CMV for example GenBank Accession No. NC\_001347), respiratory syncytial virus (RSV for example GenBank Accession No. NC\_001781), influenza virus (for example example GenBank Accession No. AF037412, rhinovirus (for example, GenBank accession numbers: D00239,  
15 X02316, X01087, L24917, M16248, K02121, X01087), papillomavirus (for example GenBank Accession No. NC\_001353), Herpes Simplex Virus (HSV for example GenBank Accession No. NC\_001345), and other viruses such as HTLV (for example GenBank Accession No. AJ430458). Due to the high sequence variability of many viral genomes, selection of siNA molecules for broad therapeutic applications would likely involve the  
20 conserved regions of the viral genome. Nonlimiting examples of conserved regions of the viral genomes include but are not limited to 5'-Non Coding Regions (NCR), 3'- Non Coding Regions (NCR) LTR regions and/or internal ribosome entry sites (IRES). siNA molecules designed against conserved regions of various viral genomes will enable efficient inhibition of viral replication in diverse patient populations and may ensure the  
25 effectiveness of the siNA molecules against viral quasi species which evolve due to mutations in the non-conserved regions of the viral genome.

Non-limiting examples of human genes that can be targeted using siNA molecules of the invention using methods described herein include any human RNA sequence, for example those commonly referred to by Genbank Accession Number. These RNA  
30 sequences can be used to design siNA molecules that inhibit gene expression and therefore abrogate diseases, conditions, or infections associated with expression of those genes. Such non-limiting examples of human genes that can be targeted using siNA molecules of

the invention include VEGF (for example GenBank Accession No. NM\_003376.3), VEGFr (VEGFR1 for example GenBank Accession No. XM\_067723, VEGFR2 for example GenBank Accession No. AF063658), HER1, HER2, HER3, and HER4 (for example Genbank Accession Nos: NM\_005228, NM\_004448, NM\_001982, and 5 NM\_005235 respectively), telomerase (TERT, for example GenBank Accession No. NM\_003219), telomerase RNA (for example GenBank Accession No. U86046), NFkappaB, Rel-A (for example GenBank Accession No. NM\_005228), NOGO (for example GenBank Accession No. AB020693), NOGO<sub>r</sub> (for example GenBank Accession No. XM\_015620), RAS (for example GenBank Accession No. NM\_004283), RAF (for 10 example GenBank Accession No. XM\_033884), CD20 (for example GenBank Accession No. X07203), METAP2 (for example GenBank Accession No. NM\_003219), CLCA1 (for example GenBank Accession No. NM\_001285), phospholamban (for example GenBank Accession No. NM\_002667), PTP1B (for example GenBank Accession No. M31724), PCNA (for example GenBank Accession No. NM\_002592.1), PKC-alpha (for example 15 GenBank Accession No. NM\_002737) and others. The genes described herein are provided as non-limiting examples of genes that can be targeted using siNA molecules of the invention. Additional examples of such genes are described by accession number in Beigelman *et al.*, USSN 60/363,124, filed March 11, 2002 and incorporated by reference herein in its entirety.

20 The siNA molecule of the invention can also be used in a variety of agricultural applications involving modulation of endogenous or exogenous gene expression in plants using siNA, including use as insecticidal, antiviral and anti-fungal agents or modulate plant traits such as oil and starch profiles and stress resistance.

Example 18: Diagnostic uses

25 The siNA molecules of the invention can be used in a variety of diagnostic applications, such as in the identification of molecular targets (e.g., RNA) in a variety of applications, for example, in clinical, industrial, environmental, agricultural and/or research settings. Such diagnostic use of siNA molecules involves utilizing reconstituted RNAi systems, for example, using cellular lysates or partially purified cellular lysates. 30 siNA molecules of this invention can be used as diagnostic tools to examine genetic drift and mutations within diseased cells or to detect the presence of endogenous or exogenous,

for example viral, RNA in a cell. The close relationship between siNA activity and the structure of the target RNA allows the detection of mutations in any region of the molecule, which alters the base-pairing and three-dimensional structure of the target RNA. By using multiple siNA molecules described in this invention, one can map nucleotide changes, which are important to RNA structure and function *in vitro*, as well as in cells and tissues. Cleavage of target RNAs with siNA molecules can be used to inhibit gene expression and define the role of specified gene products in the progression of disease or infection. In this manner, other genetic targets can be defined as important mediators of the disease. These experiments will lead to better treatment of the disease progression by affording the possibility of combination therapies (e.g., multiple siNA molecules targeted to different genes, siNA molecules coupled with known small molecule inhibitors, or intermittent treatment with combinations siNA molecules and/or other chemical or biological molecules). Other *in vitro* uses of siNA molecules of this invention are well known in the art, and include detection of the presence of mRNAs associated with a disease, infection, or related condition. Such RNA is detected by determining the presence of a cleavage product after treatment with a siNA using standard methodologies, for example, fluorescence resonance emission transfer (FRET).

In a specific example, siNA molecules that cleave only wild-type or mutant forms of the target RNA are used for the assay. The first siNA molecules (*i.e.*, those that cleave only wild-type forms of target RNA) are used to identify wild-type RNA present in the sample and the second siNA molecules (*i.e.*, those that cleave only mutant forms of target RNA) are used to identify mutant RNA in the sample. As reaction controls, synthetic substrates of both wild-type and mutant RNA are cleaved by both siNA molecules to demonstrate the relative siNA efficiencies in the reactions and the absence of cleavage of the "non-targeted" RNA species. The cleavage products from the synthetic substrates also serve to generate size markers for the analysis of wild-type and mutant RNAs in the sample population. Thus, each analysis requires two siNA molecules, two substrates and one unknown sample, which is combined into six reactions. The presence of cleavage products is determined using an RNase protection assay so that full-length and cleavage fragments of each RNA can be analyzed in one lane of a polyacrylamide gel. It is not absolutely required to quantify the results to gain insight into the expression of mutant RNAs and putative risk of the desired phenotypic changes in target cells. The expression of mRNA whose protein

product is implicated in the development of the phenotype (*i.e.*, disease related or infection related) is adequate to establish risk. If probes of comparable specific activity are used for both transcripts, then a qualitative comparison of RNA levels is adequate and decreases the cost of the initial diagnosis. Higher mutant form to wild-type ratios are correlated with  
5 higher risk whether RNA levels are compared qualitatively or quantitatively.

Example 19: Synthesis of siNA conjugates

The introduction of conjugate moieties to siNA molecules of the invention is accomplished either during solid phase synthesis using phosphoramidite chemistry described above, or post-synthetically using, for example, N-hydroxysuccinimide (NHS)  
10 ester coupling to an amino linker present in the siNA. Typically, a conjugate introduced during solid phase synthesis will be added to the 5'-end of a nucleic acid sequence as the final coupling reaction in the synthesis cycle using the phosphoramidite approach. Coupling conditions can be optimized for high yield coupling, for example by modification of coupling times and reagent concentrations to effectuate efficient coupling. As such, the  
15 5'-end of the sense strand of a siNA molecule is readily conjugated with a conjugate moiety having a reactive phosphorus group available for coupling (e.g., a compound having Formulae 1, 5, 8, 55, 56, 57, 60, 86, 92, 104, 110, 113, 115, 116, 117, 118, 120, or 122) using the phosphoramidite approach, providing a 5'-terminal conjugate (see for example **Figure 65**).

20 Conjugate precursors having a reactive phosphorus group and a protected hydroxyl group can be used to incorporate a conjugate moiety anywhere in the siNA sequence, such as in the loop portion of a single stranded hairpin siNA construct (see for example **Figure 66**). For example, using the phosphoramidite approach, a conjugate moiety comprising a phosphoramidite and protected hydroxyl (e.g., a compound having Formulae 86, 92, 104,  
25 113, 115, 116, 117, 118, 120, or 122 herein) is first coupled at the desired position within the siNA sequence using solid phase synthesis phosphoramidite coupling. Second, removal of the protecting group (e.g., dimethoxytrityl) allows coupling of additional nucleotides to the siNA sequence. This approach allows the conjugate moiety to be positioned anywhere within the siNA molecule.

30 Conjugate derivatives can also be introduced to a siNA molecule post synthetically. Post synthetic conjugation allows a conjugate moiety to be introduced at any position



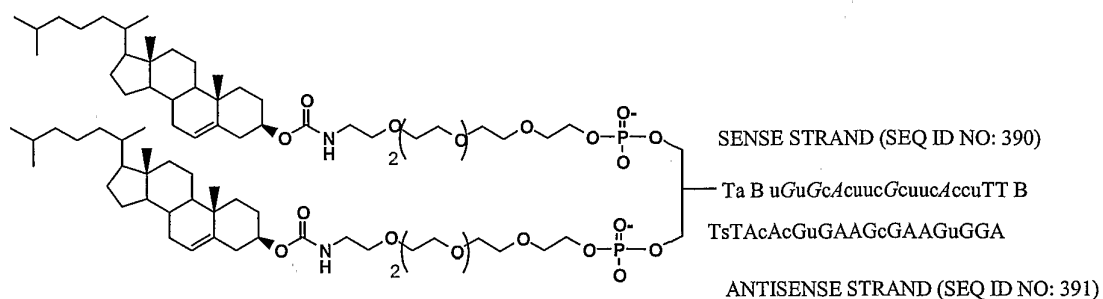
within the siNA molecule where an appropriate functional group is present (e.g., a C5 alkylamine linker present on a nucleotide base or a 2'-alkylamine linker present on a nucleotide sugar can provide a point of attachment for an NHS-conjugate moiety). Generally, a reactive chemical group present in the siNA molecule is unmasked following  
5 synthesis, thus allowing post-synthetic coupling of the conjugate to occur. In a non-limiting example, an protected amino linker containing nucleotide (e.g., TFA protected C5 propylamino thymidine) is introduced at a desired position of the siNA during solid phase synthesis. Following cleavage and deprotection of the siNA, the free amine is made available for NHS ester coupling of the conjugate at the desired position within the  
10 siNA sequence, such as at the 3'-end of the sense and/or antisense strands, the 3' and/or 5'-end of the sense strand, or within the siNA sequence, such as in the loop portion of a single stranded hairpin siNA sequence.

A conjugate moiety can be introduced at different locations within a siNA molecule using both solid phase synthesis and post-synthetic coupling approaches. For example,  
15 solid phase synthesis can be used to introduce a conjugate moiety at the 5'-end of the siNA (e.g., sense strand) and post-synthetic coupling can be used to introduce a conjugate moiety at the 3'-end of the siNA (e.g., sense strand and/or antisense strand). As such, a siNA sense strand having 3' and 5' end conjugates can be synthesized (see for example **Figure 65**). Conjugate moieties can also be introduced in other combinations, such as at the 5'-end,  
20 3'-end and/or loop portions of a siNA molecule (see for example **Figure 66**).

Example 20: Pharmacokinetics of siNA conjugates (**Figure 67**)

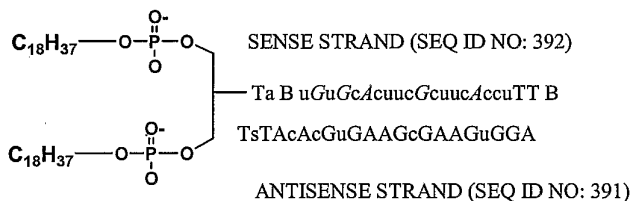
Three nuclease resistant siNA molecule targeting site 1580 of hepatitis B virus (HBV) RNA were designed using Stab 7/8 chemistry (see **Table IV**) and a 5'-terminal conjugate moiety.

25 One siNA conjugate comprises a branched cholesterol conjugate linked to the sense strand of the siNA. The "cholesterol" siNA conjugate molecule has the structure shown below:



where T stands for thymidine, B stands for inverted deoxyabasic, G stands for 2'-deoxy guanosine, A stands for 2'-deoxy adenosine, G stands for 2'-O-methyl guanosine, A stands for 2'-O-methyl adenosine, u stands for 2'-fluoro uridine, c stands for 2'-fluoro cytidine, a stands for adenosine, and s stands for phosphorothioate linkage.

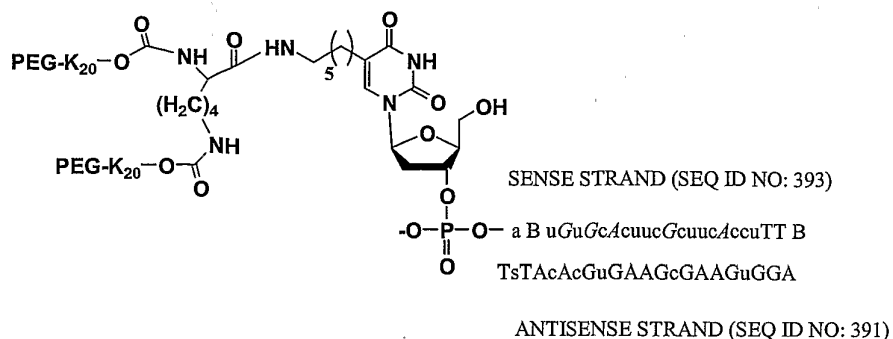
Another siNA conjugate comprises a branched phospholipid conjugate linked to the sense strand of the siNA. The "phospholipid" siNA conjugate molecule has the structure shown below:



10

where T stands for thymidine, B stands for inverted deoxyabasic, G stands for 2'-deoxy guanosine, A stands for 2'-deoxy adenosine, G stands for 2'-O-methyl guanosine, A stands for 2'-O-methyl adenosine, u stands for 2'-fluoro uridine, c stands for 2'-fluoro cytidine, a stands for adenosine, and s stands for phosphorothioate linkage.

Another siNA conjugate comprises a polyethylene glycol (PEG) conjugate linked to the sense strand of the siNA. The "PEG" siNA conjugate molecule has the structure shown below:



where T stands for thymidine, B stands for inverted deoxyabasic, G stands for 2'-deoxy guanosine, A stands for 2'-deoxy adenosine, G stands for 2'-O-methyl guanosine, A stands for 2'-O-methyl adenosine, u stands for 2'-fluoro uridine, c stands for 2'-fluoro cytidine, a stands for adenosine, and s stands for phosphorothioate linkage.

The Cholesterol, Phospholipid, and PEG conjugates were evaluated for pharmacokinetic properties in mice compared to a non-conjugated siNA construct having matched chemistry and sequence. This study was conducted in female CD-1 mice approximately 26 g (6-7 weeks of age). Animals were housed in groups of 3. Food and water were provided ad libitum. Temperature and humidity were according to Pharmacology Testing Facility performance standards (SOP's) which are in accordance with the 1996 Guide for the Care and Use of Laboratory Animals (NRC). Animals were acclimated to the facility for at least 3 days prior to experimentation.

Absorbance at 260 nm was used to determine the actual concentration of the stock solution of pre-annealed HBV siNA. An appropriate amount of HBV siNA was diluted in sterile veterinary grade normal saline (0.9%) based on the average body weight of the mice. A small amount of the antisense (Stab 7) strand was internally labeled with gamma 32P-ATP. The 32P-labeled stock was combined with excess sense strand (Stab 8) and annealed. Annealing was confirmed prior to combination with unlabeled drug. Each mouse received a subcutaneous bolus of 30 mg/kg (based on duplex) and approximately 10 million cpm (specific activity of approximately 15 cpm/ng).

Three animals per timepoint (1, 4, 8, 24, 72, 96 h) were euthanized by CO<sub>2</sub> inhalation followed immediately by exsanguination. Blood was sampled from the heart and collected in heparinized tubes. After exsanguination, animals were perfused with 10-15 mL of sterile veterinary grade saline via the heart. Samples of liver were then collected and frozen.

Tissue samples were homogenized in a digestion buffer prior to compound quantitation. Quantitation of intact compound was determined by scintillation counting followed by PAGE and phosphorimage analysis. Results are shown in Figure 43. As shown in the figure, the conjugated siNA constructs shown vastly improved liver PK compared to the unconjugated siNA construct.

Example 21: Cell culture of siNA conjugates (Figure 68)

The Cholesterol conjugates and Phospholipid conjugated siNA constructs described in Example 20 above were evaluated for cell culture efficacy in a HBV cell culture system.

*Transfection of HepG2 Cells with psHBV-1 and siNA*

The human hepatocellular carcinoma cell line Hep G2 was grown in Dulbecco's modified Eagle media supplemented with 10% fetal calf serum, 2 mM glutamine, 0.1 mM nonessential amino acids, 1 mM sodium pyruvate, 25 mM Hepes, 100 units penicillin, and 100 µg/ml streptomycin. To generate a replication competent cDNA, prior to transfection the HBV genomic sequences are excised from the bacterial plasmid sequence contained in the psHBV-1 vector. Other methods known in the art can be used to generate a replication competent cDNA. This was done with an EcoRI and Hind III restriction digest. Following completion of the digest, a ligation was performed under dilute conditions (20 µg/ml) to favor intermolecular ligation. The total ligation mixture was then concentrated using Qiagen spin columns.

*siNA Activity Screen and Dose Response Assay*

Transfection of the human hepatocellular carcinoma cell line, Hep G2, with replication-competent HBV DNA results in the expression of HBV proteins and the production of virions. To test the efficacy of siNA conjugates targeted against HBV RNA, the Cholesterol siNA conjugate and Phospholipid siNA conjugate described in Example 12 were compared to a non-conjugated control siNA (see Figure 68). An inverted sequence duplex was used as a negative control for the unconjugated siNA. Dose response studies were performed in which HBV genomic DNA was transfected with HBV genomic DNA with lipid at 12.5 µg/ml into Hep G2 cells. 24 hours after transfection with HBV DNA, cell culture media was removed and siNA duplexes were added to cells without lipid at 10 µM,

5, uM, 2.5 uM, 1 uM, and 100 nm and the subsequent levels of secreted HBV surface antigen (HBsAg) were analyzed by ELISA 72 hours post treatment (see Figure 44). To determine siNA activity, HbsAg levels were measured following transfection with siNA. Immulon 4 (Dynax) microtiter wells were coated overnight at 4° C with anti-HBsAg Mab  
5 (Biostride B88-95-31ad,ay) at 1 µg/ml in Carbonate Buffer (Na<sub>2</sub>CO<sub>3</sub> 15 mM, NaHCO<sub>3</sub> 35 mM, pH 9.5). The wells were then washed 4x with PBST (PBS, 0.05% Tween® 20) and blocked for 1 hr at 37° C with PBST, 1% BSA. Following washing as above, the wells were dried at 37° C for 30 min. Biotinylated goat anti-HBsAg (Accurate YVS1807) was  
10 washed 4x with PBST. Streptavidin/Alkaline Phosphatase Conjugate (Pierce 21324) was diluted to 250 ng/ml in PBST, and incubated in the wells for 1 hr. at 37° C. After washing as above, p-nitrophenyl phosphate substrate (Pierce 37620) was added to the wells, which were then incubated for 1 hour at 37° C. The optical density at 405 nm was then determined. As shown in **Figure 68**, the phospholipid and cholesterol conjugates  
15 demonstrate marked dose dependent inhibition of HBsAg expression compared to the unconjugated siNA construct when delivered to cells without any transfection agent (lipid).

#### Example 22: Ex vivo stability of siNA constructs

Chemically modified siNA constructs were designed and synthesized in order to improve resistance to nucleases while maintaining silencing in cell culture systems.  
20 Modified strands, designated Stab 4, Stab 5, Stab 7, Stab 8, and Stab 11 (**Table IV**), were tested in three sets of duplexes that demonstrated a range of stability and activity. These duplexes contained differentially modified sense and antisense strands. All modified sense strands contain terminal 5' and 3' inverted abasic caps, while antisense strands possess a 3'  
25 terminal phosphorothioate linkage. The results characterize the impact of chemical modifications on nuclease resistance in *ex vivo* models of the environments sampled by drugs.

Active siNAs were assessed for their resistance to degradation in serum and liver extracts. Stability in blood will be a requirement for a systemically administered siNA, and an anti-HBV or anti-HCV siNA would require stability and activity in the hepatic  
30 intracellular environment. Liver extracts potentially provide an extreme nuclease model where many catabolic enzymes are present. Both mouse and human systems were assessed.

Individual strands of siNA duplexes were internally labeled with  $^{32}\text{P}$  and incubated as single strands or as duplex siRNAs in human or mouse serum and liver extracts. Representative data is shown in **Table VI**. Throughout the course of the experiments, constant levels of ribonuclease activity were verified. The extent and pattern of all-RNA siNA degradation (3 minute time point) did not change following preincubation of serum or liver extract at  $37^\circ\text{C}$  for up to 24 hours.

The biological activity of siRNAs containing all-ribose residues has been well established. The extreme instability ( $t_{1/2} = 0.017$  hours) of these compounds in serum underscores the need for chemical modification for use in systemic therapeutic applications. The Stab 4/5 duplex modifications provide significant stability in human and mouse serum ( $t_{1/2}$ 's = 10 – 408 hours) and human liver extract ( $t_{1/2}$ 's = 28 – 43 hours). In human serum the Stab 4 strand chemistry in the context of the Stab 4/5 duplex, possesses greater stability than the Stab 5 strand chemistry ( $t_{1/2} = 408$  vs. 39 hours). This result highlights the impact terminal modifications have on stability. A fully-modified Stab 7/11 construct (no ribonucleotides present) was generated from the Stab 4/5 constructs by substituting the ribonucleotides in all purine positions with deoxyribonucleotides. Another fully modified construct, Stab 7/8, was generated by replacing all purine positions in the antisense strand with 2'-O-methyl nucleotides. This proved to be the most stable antisense strand chemistry observed, with  $t_{1/2} = 816$  hours in human liver extract.

The dramatic stability of Stab 8 modifications was also observed when non-duplexed single strands were incubated in human serum and liver extract, as shown in **Table VII**. An approximate five-fold increase in serum stability is seen for the double stranded constructs, compared to that observed for the individual strands. In liver extract, the siNA duplex provides even greater stability compared to the single strands. For example, the Stab 5 chemistry is greater than 100-fold more stable in the Stab 4/5 duplex relative to its stability alone.

Terminal modifications have a large impact on stability in human serum, as can be seen from a comparison of sense verses antisense stabilities in duplex form, and the Stab 4 and Stab 5 single-strand stabilities. Therefore, a number of 3' antisense capping moieties on Stab 4/5 chemistry duplexes were assessed for their contribution to stability in human serum. The structures of these modifications are shown in **Figure 22**, and resultant half-lives are shown in **Table VIII**. A wide range of different stabilities were observed, from half-lives as short as one hour to greater than 770 hours. Thus, in the context of 2'-fluoro modified pyrimidines, 3'-exonuclease becomes the primary mode of attack on duplexes in human serum; a number of chemistries minimize this site of attack. These results suggest that susceptibility to 3' exonucleases is a major path to degradation in the serum.

Example 23: Activity of siNA molecules delivered via hydrodynamic injection

An in vivo mouse model that utilizes hydrodynamic tail vein injection of a replication competent HBV vector has been used to assess the activity of chemically stabilized siRNA targeted to HBV RNA. The hydrodynamic delivery of nucleic acids in the mouse has been described by Liu *et al.*, 1999, *Gene Therapy*, 6, 1258-1266, who showed that the vast majority of the nucleic acid is delivered to the liver by this technique. The use of the hydrodynamic technology to develop a HBV mouse model has been described by Yang *et al.*, 2002, *PNAS*, 99, 13825-13830. In the vector-based model, HBV replicates in the liver for approximately 10 days, resulting in detectable levels of HBV RNA and antigens in the liver and HBV DNA and antigens in the serum.

To assess the activity of chemically stabilized siNAs against HBV, co-injection of the siNAs along with the HBV vector was done in mouse strain C57BL/J6. The HBV vector used, pWTD, is a head-to-tail dimer of the complete HBV genome (see for example Buckwold *et al.*, 1996, *J. Virology*, 70, 5845-5851). For a 20 gram mouse, a total injection of 1.6 ml containing 10  $\mu$ g or 1  $\mu$ g of pWTD and 100  $\mu$ g of siNA duplex in saline, was injected into the tail vein within 5 seconds. For a larger mouse, the volume is scaled to maintain a level of 140% of the blood volume of the mouse. The injection is done using a 3 cc syringe and 27g1/2 needle. The animals were sacrificed at 72 hrs post-injection. Animals were treated with siNA constructs and matched chemistry inverted controls. Analysis of the HBV DNA (**Figure 80**) and HBsAg (**Figure 81**) levels in serum was

conducted by real-time PCR and ELISA respectively. The levels of HBV RNA in the liver (**Figure 82**) were analyzed by real-time RT-PCR. In a separate experiment, analysis of HBV DNA levels in serum was carried out at 5 days and 7 days (**Figure 83**) after co-injection of siNA and the HBV vector.

5 This same model was used to evaluate the efficacy of siNA formulated with polyethyleneimine polyethylene glycol tri-N-acetyl-galactosamine (PEI-PEG-triGAL, **Figure 93**). Active siNA (Compound # 31335/31337) formulations were compared to inactive inverted control siNA (Compound # 31336/31338) formulations. In order to allow recovery of the liver from the disruption caused by HDI, systemic dosing was started 96 hrs  
10 post-HDI. Each group received two days of dosing, and the animals were then sacrificed 24 hrs after the last dose. Animals were dosed with siNA formulated with PEI-PEG-triGal at siNA concentrations of 0.1, 0.3, and 1.0 mg/kg/day. Analysis of the HBV DNA (**Figure 91**) and HBsAg (**Figure 92**) levels in serum was conducted by real-time PCR and ELISA respectively. The levels of HBV RNA in the liver are analyzed by real-time RT-PCR. As  
15 shown in the figures, the active PEI-PEG-triGAL siNA formulation shows significant inhibition of HBV DNA and HBsAg levels in serum compared to the inactive formulation.

Example 23: In vivo activity of systemically dosed siNA molecules delivered via intravenous administration

Once the *in vivo* potency modified siNA against HBV was demonstrated by  
20 co-administration by HDI as described above, the level of anti-HBV activity of the molecule systemically dosed via conventional intravenous injection was investigated following the HDI delivery of the HBV vector. Since there have been reports of initial liver damage following hydrodynamic injection, dosing of siNAs was begun 72 hours post HDI. Examination of both liver ALT/AST levels and histopathology following HDI confirmed  
25 reports in the literature that the liver returns to near normal status by 72 hrs after the initial HDI induced injury (data not shown). To assess *in vivo* activity of systemically dosed siNA, 0.3 ug of the pWTD HBV vector was HDI administered, and 72 hours later the siNA or inverted controls were dosed via standard intravenous injection at 30, 10, or 3 ug/kg TID for 2 days. The animals were sacrificed 18 hours after the last dose and levels of serum  
30 HBV DNA were examined. **Figure 102** shows log<sub>10</sub> copies/ml of serum HBV DNA for the siNA (Stab 7/8 33214/33254, Table III), inverted control (Stab 7/8 33578/33579, Table



III), and saline treated groups. A dose dependent reduction in serum HBV DNA levels was observed in the siNA treated groups in comparison to the inverted control or saline groups. A statistically significant ( $P < 0.01$ ) reduction of 0.93 log was observed in the 30mg/kg group as compared to the saline group. This result demonstrates *in vivo* activity of a systemically administered siNA. **Figure 103** shows activity of a fully stabilized siNA (Stab Active = 33214/33254, Table III) construct compared to a matched chemistry inverted control (Stab Inv = 33578/33579, Table III), an all RNA siNA construct having identical sequence (RNA active) and a corresponding all RNA inverted control (RNA Inv) in the HBV Co-HDI mouse model described above. A hydrodynamic tail vein injection (HDI) containing 1 ug of the pWTD HBV vector and 0, 0.03, 0.1, 0.3 or 1.0 ug of siNA was performed on C57BL/J6 mice. Active siNA duplexes and inverted sequence controls in both native RNA and stabilized chemistry were tested. The levels of serum HBV DNA and HBsAg were measured 72 hrs post injection. A dose dependent reduction in both HBV DNA and HBsAg levels was observed with both the native RNA and stabilized siNAs. However, the magnitude of the reduction observed in the stabilized siNAs treated groups was 1.5 log greater for both endpoints at the high dose level. **Figure 103A** shows results for HBV serum DNA levels, **Figure 103B** shows results for serum HBsAg levels, and **Figure 103C** shows results for liver HBV RNA levels in this study.

#### Example 24: Activity screens using chemically modified siNA

Two formats can be used to identify active chemically modified siNA molecules against target nucleic acid molecules (e.g., RNA). One format involves screening unmodified siNA constructs in an appropriate system (e.g., cell culture or animal models) then applying chemical modifications to the sequence of identified leads and rescreening the modified constructs. Another format involves direct screening of chemically modified constructs to identify chemically modified leads (see for example the Stab 7/8 HCV screen shown in **Figure 86** and the Stab 7/8 HBV screen shown **Figure 87**, as described above). The latter approach can be useful in identifying active constructs that are specific to various combinations of chemical modifications (e.g., Stab 1-18 chemistries shown in **Table V** herein). Additionally, different iterations of such chemical modifications can be assessed using active chemically modified leads and appropriate rules for selective active constructs given a particular chemistry can be established using this approach. Non-limiting examples of such activity screen are described below.

*Activity screen of Stab 7/8 constructs targeting luciferase RNA*

HeLa cells were co-transfected with pGF3 vector (250ng/well), renilla luciferase vector (10 ng/well) and siNA (0.5 - 25 nM) using 0.5 ul lipofectamine2000 per well. Twenty-four hours post-transfection, the cells were assayed for luciferase activity using the  
5 Promega Dual Luciferase Assay Kit per the manufacturer's instruction. siNA constructs having high levels of activity were identified and tested in a dose response assay with concentrations ranging from 0.5 to 25 nM. Results for siNA constructs targeting sites 80, 237, and 1478 are shown in **Figure 84** and sites 1544 and 1607 are shown in **Figure 85**. As shown in the Figures, several active Stab 7/8 constructs were identified that demonstrate  
10 potent dose related inhibition of luciferase expression.

*Activity screen of combination siNA constructs targeting HBV RNA in HepG2 cells*

The HBV HepG2 cell culture system described in Example 13 above was utilized to evaluate the efficacy of various combinations of chemical modifications (**Table V**) in the sense strand and antisense strand of siNA molecules as compared to matched chemistry  
15 inverted controls. To determine siNA activity, HbsAg levels were measured following transfection with siNA. Immulon 4 (Dynax) microtiter wells were coated overnight at 4° C with anti-HBsAg Mab (Biostride B88-95-31ad,ay) at 1 µg/ml in Carbonate Buffer (Na<sub>2</sub>CO<sub>3</sub> 15 mM, NaHCO<sub>3</sub> 35 mM, pH 9.5). The wells were then washed 4x with PBST (PBS, 0.05% Tween® 20) and blocked for 1 hr at 37° C with PBST, 1% BSA. Following  
20 washing as above, the wells were dried at 37° C for 30 min. Biotinylated goat ant-HBsAg (Accurate YVS1807) was diluted 1:1000 in PBST and incubated in the wells for 1 hr. at 37° C. The wells were washed 4x with PBST. Streptavidin/Alkaline Phosphatase Conjugate (Pierce 21324) was diluted to 250 ng/ml in PBST, and incubated in the wells for 1 hr. at 37° C. After washing as above, p-nitrophenyl phosphate substrate (Pierce 37620) was  
25 added to the wells, which were then incubated for 1 hour at 37( C. The optical density at 450 nm was then determined. Results of the combination HBV siNA screen are shown in Figures 88-90. As shown in the Figures, the various combinations of differing sense and antisense chemistries (e.g., sense/antisense constructs having Stab 7/8, 7/10, 7/11, 9/8, 9/10, 6/10, 16/8, 16/10, 18/8, 18/10,  
30 4/8, 4/10, 7/5, 9/5, and 9/11 chemistry) result in active siNA constructs.

## Example 25: Duplex Forming oligonucleotide mediated inhibition of gene expression

## Palindromic Frequency Determination

In designing DFO constructs, the search for palindromic sites in target sequences can provide target sites well suited for DFO mediated inhibition of gene expression, as opposed to randomly screening sites for activity with non-DFO oligonucleotides. The length of  
5 palindrome can define the overall length of the DFO. The probability of the occurrence of various palindromes was calculated ranging from 6 nucleotides to 14 nucleotides in an artificially generated 200K-gene sequence via a MICROSOFT EXCEL algorithm (see Figure 107). The simulation revealed that 6-mer palindromes typically occur once for every  
10 given 64-nucleotide sequence. An 8-mer palindrome was found to occur once for every 250-nucleotide sequence. These calculated frequencies matched well with the observed frequencies of palindrome in defined target sequences. This allowed the estimation that approximately 78 6-mer palindromes should exist on average in any given 5K gene. Evaluation for the presence of 6-mer palindromes in various genes resulted in a large  
15 number of palindromic sites identified (see Figure 108). This algorithm considers only the Watson-Crick base pairs and excludes the presence of any mismatched and wobble base pairs. Including mismatches, wobble pairs and non-Watson-Crick base pairs can result in a large number of semi-palindromic sites suitable for the design of minimal duplex forming oligonucleotides.

20 To test the hypothesis that palindromic sites could be used for design and search for self-complementary oligos capable of inducing RNAi in mammalian cells, we randomly selected 12 palindromic sites in mTGFbR1 gene. These sites were included in the design of single strand siRNA as described previously. None of these siRNAs contained TT overhangs in duplex form but contained an inverted abasic nucleotide to protect from  
25 3'-exonucleases. Analysis of these DFOs for the RNAi response in E147Ts cells resulted in 4 out of 12 sequences that reduced mRNA levels to less than or equal to 40% at 25 nM concentration. Retesting the active sequences on a different day resulted in mRNA knock down by approximately 80%.

30 Identification of 4 active DFOs out of 12 is of the same order as the screening of standard 21 bp siRNA duplexes for RNAi response. This indicates that self-complementary

oligos could be an alternative for the design of second-generation drugs based on RNAi mechanism.

#### Self complementary DFO constructs targeting VEGFR1

Using the methods described herein,, self complementary DFO constructs  
5 comprising palindrome or repeat nucleotide sequences were designed against VEGFR1  
target RNA. These DFO constructs utilized the identification of palindromic or repeat  
sequences in a target nucleic acid sequence of interest, generally these palindrome/repeat  
sequences comprise about 2 to about 12 nucleotides in length were are selected to originate  
at the 5'-region of the target nucleic acid sequence. A nucleotide sequence that was  
10 complementary to target nucleic acid sequence adjacent (3') to the palindrome/repeat  
sequence was incorporated at the 5'-end of the palindrome/repeat sequence in the DFO  
molecule. Lastly, a nucleic sequence that was inverse repeat of the sequence at the 5' end  
of the palindrome/repeat sequence was inserted at the 3' end of the palindrome/repeat  
sequence such that the full length DFO sequence comprised self complementary sequence.  
15 This design of DFO construct allows for the formation of a duplex oligonucleotide in which  
both strands comprise the same sequence (e.g., see **Figure 94**). Generally, the longer the  
repeat identified in the target nucleic acid sequence, the shorter the resulting DFO sequence  
will be. For example, if the target sequence is 17 nucleotides in length and there is no  
repeat found in the sequence, the resulting DFO construct will be, for example,  $17 + 0 + 17$   
20  $= 34$  nucleotides in length. The first 17 nucleotides represent sequence complementary to  
the target nucleic acid sequence, the 0 represents the lack of a palindrome sequence, and the  
second 17 nucleotides represent inverted repeat sequence of the first 17 nucleotides. If a 2  
nucleotide repeat is utilized, the resulting DFO construct will be, for example,  $15 + 2 + 15 =$   
32 nucleotides in length. If a 4 nucleotide repeat is utilized, the resulting DFO construct  
25 will be, for example,  $13 + 4 + 13 = 30$  nucleotides in length. If a 6 nucleotide repeat is  
utilized, the resulting DFO construct will be, for example,  $11 + 6 + 11 = 28$  nucleotides in  
length. If a 8 nucleotide repeat is utilized, the resulting DFO construct will be, for example,  
 $9 + 8 + 9 = 26$  nucleotides in length. If a 10 nucleotide repeat is utilized, the resulting DFO  
construct will be, for example,  $7 + 10 + 7 = 24$  nucleotides in length. If a 12 nucleotide  
30 repeat is utilized, the resulting DFO construct will be, for example,  $5 + 12 + 5 = 22$   
nucleotides in length and so forth. Thus, for each nucleotide reduction in the target site, the  
DFO length can be shortened by 2 nucleotides. These same principles can be utilized for a

target site having different length nucleotide sequences, such as target sites comprising 14 to 24 nucleotides. In addition, various combinations of 5' and 3' overhang sequences (e.g., TT) can be introduced to the DFO constructs designed with palindrome/repeat sequences. Furthermore, palindrome/repeat sequences can be added to the 5'-end of a DFO sequence  
5 having complementarity to any target nucleic acid sequence of interest, enabling self complementary palindrome/repeat DFO constructs to be designed against any target nucleic acid sequence (see for example **Figures 95-96**).

Self complementary DFO palindrome/repeat sequences shown in **Table I** (compound # 32808, 32809, 32810, 32811, and 32812) were designed against VEGFR1  
10 RNA targets and were screened in cell culture experiments along with chemically modified siNA constructs (compound #s 32748/32755, 33282/32289, 31270/31273) with known activity with matched chemistry inverted controls (compound #s 32772/32779, 32296/32303, 31276/31279) and untreated cells along with a trasfection control (LF2K), see **Figure 105**. HAEC cells were transfected with 0.25 ug/well of lipid complexed with  
15 25 nM DFO targeting VEGFR1 site 1229. Cells were incubated at 37° for 24h in the continued presence of the DFO transfection mixture. At 24h, RNA was prepared from each well of treated cells. The supernatants with the transfection mixtures were first removed and discarded, then the cells were lysed and RNA prepared from each well. Target gene expression following treatment was evaluated by RT-PCR for the VEGFR1 mRNA and for  
20 a control gene (36B4, an RNA polymerase subunit) for normalization. Compound # 32812, a 29 nucleotide self complementary DFO construct targeting VEGFR1 site 1229 displayed potent inhibition of VEGFR1 RNA expression in this system (see for example **Figure 105**).

#### *Self complementary DFO constructs targeting HBV RNA*

Self complementary DFO constructs comprising palindrome or repeat nucleotide  
25 sequences (see **Table I**) were designed against HBV target RNA and were screened in HepG2 cells. Transfection of the human hepatocellular carcinoma cell line, Hep G2, with replication-competent HBV DNA results in the expression of HBV proteins and the production of virions. The human hepatocellular carcinoma cell line Hep G2 was grown in Dulbecco's modified Eagle media supplemented with 10% fetal calf serum, 2 mM  
30 glutamine, 0.1 mM nonessential amino acids, 1 mM sodium pyruvate, 25 mM Hepes, 100 units penicillin, and 100 µg/ml streptomycin. To generate a replication competent cDNA,

prior to transfection the HBV genomic sequences are excised from the bacterial plasmid sequence contained in the psHBV-1 vector. Other methods known in the art can be used to generate a replication competent cDNA. This was done with an EcoRI and Hind III restriction digest. Following completion of the digest, a ligation was performed under  
5 dilute conditions (20 µg/ml) to favor intermolecular ligation. The total ligation mixture was then concentrated using Qiagen spin columns.

To test the efficacy of DFOs targeted against HBV RNA, DFO duplexes targeting HBV pregenomic RNA were co-transfected with HBV genomic DNA once at 25 nM with lipid at 12.5 µg/ml into Hep G2 cells, and the subsequent levels of secreted HBV surface  
10 antigen (HBsAg) were analyzed by ELISA. A DFO construct comprising self complementary sequence (compound # 32221) was assayed with a chemically modified siNA targeting HBV site 1580 (compound # 31335/31337), a corresponding matched chemistry inverted control (compound # 31336/31338), and untreated cells. The self  
15 complementary DFO construct was tested both as a preannealed duplex (compound # 32221) or as a single stranded hairpin (compound # 32221 fold), as confirmed by gel electrophoresis, (see **Figure 106**). Immulon 4 (Dynax) microtiter wells were coated overnight at 4° C with anti-HBsAg Mab (Biostride B88-95-31ad,ay) at 1 µg/ml in Carbonate Buffer (Na<sub>2</sub>CO<sub>3</sub> 15 mM, NaHCO<sub>3</sub> 35 mM, pH 9.5). The wells were then  
20 washed 4x with PBST (PBS, 0.05% Tween® 20) and blocked for 1 hr at 37° C with PBST, 1% BSA. Following washing as above, the wells were dried at 37( C for 30 min. Biotinylated goat anti-HBsAg (Accurate YVS1807) was diluted 1:1000 in PBST and incubated in the wells for 1 hr. at 37( C. The wells were washed 4x with PBST. Streptavidin/Alkaline Phosphatase Conjugate (Pierce 21324) was diluted to 250 ng/ml in PBST, and incubated in the wells for 1 hr. at 37( C. After washing as above, p-nitrophenyl  
25 phosphate substrate (Pierce 37620) was added to the wells, which were then incubated for 1 hour at 37( C. The optical density at 450 nm was then determined. As shown in Figure 106, the self complementary DFO construct 32221 in duplex form shows significant inhibition of HBsAg.

*Self complementary DFO constructs targeting TGF-beta receptor RNA*

30 Using the methods described herein,, self complementary DFO constructs comprising palindrome or repeat nucleotide sequences were designed against TGF-beta

receptor target RNA. Self complementary DFO palindrome/repeat sequences shown in Table I (e.g., compound # 35038, 35041, 35044, and 35045) were designed against TGF-beta receptor RNA targets and were screened in cell culture experiments and irrelevant controls (Control 1, Control 2) and untreated cells along with a transfection control (LF2K), see Figure 109. NMuMg cells were transfected with 0.5 uL/well of lipid complexed with 25 and 100 nM DFO. Cells were incubated at 37° for 24h in the continued presence of the DFO transfection mixture. At 24h, RNA was prepared from each well of treated cells. The supernatants with the transfection mixtures were first removed and discarded, then the cells were lysed and RNA prepared from each well. Target gene expression following treatment was evaluated by RT-PCR for the TGF-beta receptor mRNA and for a control gene (36B4, an RNA polymerase subunit) for normalization. As shown in Figure 109, the DFO constructs displayed potent inhibition of TGF-beta receptor RNA expression in this system.

Example 26: Multifunctional siNA mediated inhibition of gene expression

15 *Multifunctional siNA design*

Once target sites have been identified for multifunctional siNA constructs, each strand of the siNA is designed with a complementary region of length, for example, between about 18 and about 28 nucleotides, that is complementary to a different target nucleic acid sequence. Each complementary region is designed with an adjacent flanking region of about 4 to about 22 nucleotides that is not complementary to the target sequence, but which comprises complementarity to the complementary region of the other sequence (see for example Figure 96). Hairpin constructs can likewise be designed (see for example Figure 97). Identification of complementary, palindrome or repeat sequences that are shared between the different target nucleic acid sequences can be used to shorten the overall length of the multifunctional siNA constructs (see for example Figures 98 and 99).

In a non-limiting example, a multifunctional siNA is designed to target two separate nucleic acid sequences. The goal is to combine two different siNAs together in one siNA that is active against two different targets. The siNAs are joined in a way that the 5' of each strand starts with the "antisense" sequence of one of two siRNAs as shown in italics below.

3' TTAGAAACCAGACGUAAGUGU GGUACGACCUGACGACCGU 5' SEQ ID  
NO: 1124

5' UCUUUGGUCUGCAUUCACAC CAUGCUGGACUGCUGGCATT3' SEQ ID  
NO: 1125

5 RISC is expected to incorporate either of the two strands from the 5' end. This would lead to two types of active RISC populations carrying either strand. The 5' 19 nt of each strand will act as guide sequence for degradation of separate target sequences.

In another example, the size of multifunctional siNA molecules is reduced by either finding overlaps or truncating the individual siNA length. The exemplary exercise  
10 described below indicates that for any given first target sequence, a shared complementary sequence in a second target sequence is likely to be found.

The number of spontaneous matches of short polynucleotide sequences (e.g., less than 14 nucleotides) that are expected to occur between two longer sequences generated independent of one another was investigated. A simulation using the uniform random  
15 generator SAS V8.1 utilized a 4,000 character string that was generated as a random repeating occurrence of the letters {ACGU}. This sequence was then broken into the nearly 4000 overlapping sets formed by taking S1 as the characters from positions (1,2...n), S2 from positions (2,3..., n+1) completely through the sequence to the last set, S 4000-n+1 from position (4000-n+1,...,4000). This process was then repeated for a second 4000  
20 character string. Occurrence of same sets (of size n) were then checked for sequence identity between the two strings by a sorting and match-merging routine. This procedure was repeated for sets of 9-11 characters. Results were an average of 55 matching sequences of length n= 9 characters (range 39 to 72); 13 common sets (range 6 to 18) for size n=10, and 4 matches on average (range 0 to 6) for sets of 11 characters. The choice of  
25 4000 for the original string length is approximately the length of the coding region of both VEGFR1 and VEGFR2. This simple simulation suggests that any two long coding regions formed independent of one-another will share common short sequences that can be used to shorten the length of multifunctional siNA constructs. In this example, common sequences of size 9 occurred by chance alone in > 1% frequency.



Below is an example of a multifunctional siNA construct that targets VEGFR1 and VEGFR2 in which each strand has a total length of 24 nt with a 14 nt self complementary region (underline). The antisense region of each siNA '1' targeting VEGFR1 and siNA '2' targeting VEGFR2 (complementary regions are shown in *italic*) are used

5 siNA '1'  
 5' *CAAUUAGAGUGGCAGUGAG* (SEQ ID NO: 1126)  
 3' GUUAAUCUCACCGUCACUC (SEQ ID NO: 1127)

10 siNA '2'  
 AGAGUGGCAGUGAGCAAAG 5' (SEQ ID NO: 1128)  
*UCUCACCGUCACUCGUUUC* 3' (SEQ ID NO: 1129)

15 Multifunctional siNA  
*CAAUUAGAGUGGCAGUGAGCAAAG* (SEQ ID NO: 1130)  
*GUUAAUCUCACCGUCACUCGUUUC* (SEQ ID NO: 1131)

20 In another example, the length of a multifunctional siNA construct is reduced by determining whether fewer base pairs of sequence homology to each target sequence can be tolerated for effective RNAi activity. If so, the overall length of multifunctional siNA can be reduced as shown below. In the following hypothetical example, 4 nucleotides (**bold**) are reduced from each 19 nucleotide siNA '1' and siNA '2' constructs. The resulting  
 25 multifunctional siNA is 30 base pairs long.

siNA '1'  
 5' *CAAUUAGAGUGGCAGUGAG* (SEQ ID NO: 1126)  
 3' GUUAAUCUCACCGUCACUC (SEQ ID NO: 1127)

30 siNA '2'  
**AGAGUGGCAGUGAGCAAAG** 5' (SEQ ID NO: 1128)  
***UCUCACCGUCACUCGUUUC*** 3' (SEQ ID NO: 1129)

35 Multifunctional siNA  
*CAAUUAGAGUGGCAGUGGCAGUGAGCAAAG* (SEQ ID NO: 1132)  
***GUUAAUCUCACCGUCACCGUCACUCGUUUC*** (SEQ ID NO: 1133)

40

*Multifunctional siNA constructs targeting HBV and PKC-alpha RNA*

In a non-limiting example, multifunctional siNA constructs targeting HBV and PKC-alpha RNA were evaluated for activity (see **Figures 110 and 111**). Multifunctional siNAs are referred to by compound numbers cross referenced in **Table I**. Total RNA was prepared from HepG2 cells 72 h after treatment with 25 nM normal (single target) and bifunctional siNAs. Quantitative RT-PCR was performed using the Invitrogen SuperScript III Platinum One-Step Quantitative RT-PCR System on an ABI PRISM 7700 Sequence Detector instrument. PCR products were normalized against those for 36B4. PKC-alpha site 1143 is targeted by the PKC-alpha-only and HBV-PKC-alpha combination siNAs. As shown in **Figure 110**, the multifunctional siNAs targeting HBV-PKC-alpha (34710/34711 and 34712/34713) are effective in inhibiting HBV RNA expression at levels similar to individual siNA molecules targeting HBV sites 263 and 1583, as compared to appropriate controls (HBV inverted control siNA to site 263; irrelevant bifunctional VEGFR1/VEGF control; and a siNA construct targeting PKC-alpha site 1143 only). As shown in **Figure 111**, the multifunctional siNAs targeting HBV-PKC-alpha (34710/34711 and 34712/34713) are effective in inhibiting PKC-alpha RNA expression at levels similar to an individual siNA molecule targeting PKC-alpha site 1143, as compared to appropriate controls (irrelevant bifunctional VEGFR1/VEGF control; and siNA constructs targeting HBV sites 263 and 1583, and untreated cells).

#### *Additional Multifunctional siNA Designs*

Three categories of additional multifunctional siNA designs are presented that allow a single siRNA molecule to silence multiple targets. The first method utilizes linkers to join siNAs (or multifunctional siNAs) in a direct manner. This can allow the most potent siNAs to be joined without creating a long, continuous stretch of RNA that has potential to trigger an interferon response. The second method is a dendrimeric extension of the overlapping or the linked multifunctional design; or alternatively the organization of siNA in a supramolecular format. The third method uses helix lengths greater than 30 base pairs. Processing of these siNAs by Dicer will reveal new, active 5' antisense ends. Therefore, the long siNAs can target the sites defined by the original 5' ends and those defined by the new ends that are created by Dicer processing. When used in combination with traditional multifunctional siNAs (where the sense and antisense strands each define a target) the approach can be used for example to target 4 or more sites.

*I. Tethered Bifunctional siNAs*

The basic idea is a novel approach to the design of multifunctional siNAs in which two antisense siNA strands are annealed to a single sense strand. The sense strand oligonucleotide contains a linker (e.g., non-nucleotide linker as described herein) and two segments that anneal to the antisense siNA strands (see **Figure 112**). The linkers can also  
5 optionally comprise nucleotide-based linkers. Several potential advantages and variations to this approach include, but are not limited to:

1. The two antisense siNAs are independent. Therefore, the choice of target sites is not constrained by a requirement for sequence conservation between two sites. Any  
10 two highly active siNAs can be combined to form a multifunctional siNA.
2. When used in combination with target sites having homology, siNAs that target a sequence present in two genes (e.g., Flt-1 site 3646, which targets VEGF-R1 and R2), the design can be used to target more than two sites. A single multifunctional siNA can be for example, used to target VEGF R1 RNA and VEGF R2 RNA (using one  
15 antisense strand of the multifunctional siNA targeting of conserved sequence between to the two RNAs) and VEGF RNA (using the second antisense strand of the multifunctional siNA targeting VEGF RNA. This approach allows targeting of the cytokins and its two main receptors using a single multifunctional siNA.
3. Multifunctional siNAs that use both the sense and antisense strands to target a gene  
20 can also be incorporated into a tethered multifunctional design. This leaves open the possibility of targeting 6 4 or more sites with a single complex.
4. It can be possible to anneal more than two antisense strands to a single tethered sense strands.
5. The design avoids long continuous stretches of dsRNA. Therefore, it is less likely  
25 to initiate an interferon response.
6. The linker (or modifications attached to it, such as conjugates described herein) can improve the pharmacokinetic properties of the complex or improve its incorporation into liposomes. Modifications introduced to the linker should not impact siNA

activity to the same extent that they would if directly attached to the siNA (see for example **Figures 118 and 119**).

7. The sense strand can extend beyond the annealed antisense strands to provide additional sites for the attachment of conjugates.
- 5 8. The polarity of the complex can be switched such that both of the antisense 3' ends are adjacent to the linker and the 5' ends are distal to the linker or combination thereof.

#### *Dendrimer and supramolecular siNAs*

- 10 In the dendrimer siNA approach, the synthesis of siNA is initiated by first synthesizing the dendrimer template followed by attaching various functional siNAs. Various constructs are depicted in **Figure 113**. The number of functional siNAs that can be attached is only limited by the dimensions of the dendrimer used.

#### 15 *Supramolecular approach to multifunctional siNA*

- The supramolecular format simplifies the challenges of dendrimer synthesis. In this format, the siNA strands are synthesized by standard RNA chemistry, followed by annealing of various complementary strands. The individual strand synthesis contains an antisense sense sequence of one siNA at the 5'-end followed by a nucleic acid or synthetic  
20 linker, such as hexaethyleneglyol, which in turn is followed by sense strand of another siNA in 5' to 3' direction. Thus, the synthesis of siNA strands can be carried out in a standard 3' to 5' direction. Representative examples of trifunctional and tetrafunctional siNAs are depicted in **Figure 114**. Based on a similar principle, higher functionality siNA constructs can be designed as long as efficient annealing of various strands is achieved.

#### 25 *Dicer enabled multifunctional siNA*

Using bioinformatic analysis of multiple targets, stretches of identical sequences shared between differing target sequences can be identified ranging from about two to about fourteen nucleotides in length. These identical regions can be designed into extended siNA helixes (e.g., >30 base pairs) such that the processing by Dicer reveals a secondary

functional 5'-antisense site (see for example **Figure 115**). For example, when the first 17 nucleotides of a siNA antisense strand (e.g., 21 nucleotide strands in a duplex with 3'-TT overhangs) are complementary to a target RNA, robust silencing was observed at 25 nM. 80% silencing was observed with only 16 nucleotide complementarity in the same format  
5 (see **Figure 117**).

Incorporation of this property into the designs of siNAs of about 30 to 40 or more base pairs results in additional multifunctional siNA constructs. The example in **Figure 115** illustrates how a 30 base-pair duplex can target three distinct sequences after processing by Dicer-RNaseIII; these sequences can be on the same mRNA or separate  
10 RNAs, such as viral and host factor messages, or multiple points along a given pathway (e.g., inflammatory cascades). Furthermore, a 40 base-pair duplex can combine a bifunctional design in tandem, to provide a single duplex targeting four target sequences. An even more extensive approach can include use of homologous sequences (e.g. VEGFR-1/VEGFR-2) to enable five or six targets silenced for one multifunctional duplex.  
15 The example in **Figure 115** demonstrates how this can be achieved. A 30 base pair duplex is cleaved by Dicer into 22 and 8 base pair products from either end (8 b.p. fragments not shown). For ease of presentation the overhangs generated by dicer are not shown – but can be compensated for. Three targeting sequences are shown. The required sequence identity overlapped is indicated by grey boxes. The N's of the parent 30 b.p. siNA are suggested  
20 sites of 2'-OH positions to enable Dicer cleavage if this is tested in stabilized chemistries. Note that processing of a 30mer duplex by Dicer RNase III does not give a precise 22+8 cleavage, but rather produces a series of closely related products (with 22+8 being the primary site). Therefore, processing by Dicer will yield a series of active siNAs. Another non-limiting example is shown in **Figure 116**. A 40 base pair duplex is cleaved by Dicer  
25 into 20 base pair products from either end. For ease of presentation the overhangs generated by dicer are not shown – but can be compensated for. Four targeting sequences are shown in four colors, blue, light-blue and red and orange. The required sequence identity overlapped is indicated by grey boxes. This design format can be extended to larger RNAs. If chemically stabilized siNAs are bound by Dicer, then strategically located  
30 ribonucleotide linkages can enable designer cleavage products that permit our more extensive repertoire of multifunctional designs. For example cleavage products not limited to the Dicer standard of approximately 22-nucleotides can allow multifunctional

siNA constructs with a target sequence identity overlap ranging from, for example, about 3 to about 15 nucleotides.

Another important aspect of this approach is its ability to restrict escape mutants. Processing to reveal an internal target site can ensure that escape mutations complementary to the eight nucleotides at the antisense 5' end will not reduce siNA effectiveness. If about 17 nucleotides of complementarity are required for RISC-mediated target cleavage, this will restrict, for example 8/17 or 47% of potential escape mutants.

Example 27: siNA length and base pair walking experiments

*siNA length walk*

10 An experiment was designed to determine the effect of based paired sequence length of siNA constructs on RNAi efficacy. A well characterized site for siNA mediated inhibition, HBV RNA site 263 was chosen and siNA molecules ranging in length from 19 to 39 ribonucleotide base pairs in length with 3'-terminal dinucleotide TT overhangs. Transfection of the human hepatocellular carcinoma cell line, Hep G2, with replication-competent HBV DNA results in the expression of HBV proteins and the production of virions. To test the efficacy of differencing length siNAs targeted against HBV RNA, several siNA duplexes targeting site 263 within HBV pregenomic RNA were co-transfected with HBV genomic DNA once at 25 nM with lipid at 12.5 ug/ml into Hep G2 cells, and the subsequent levels of HBV RNA analyzed by RT PCR compared to cells 15 treated with an inverted siNA control to site 263 and untreated cells. Results are summarized in **Figure 120**. As shown in the figure, the siNA constructs from 19 to 39 base pairs were all efficacious in inhibiting HBV RNA in this system. 20

*siNA length walk*

25 An experiment was designed to determine the effect of varying the number of nucleotides complementary to a target RNA within a fixed length siNA on RNAi efficacy. siNA molecules ranging from 14 to 18 ribonucleotide base pairs with a fixed length of 21 nucleotides that included 3'-terminal dinucleotide TT overhangs were designed to target HBV site 263 RNA. Transfection of the human hepatocellular carcinoma cell line, Hep G2, with replication-competent HBV DNA results in the expression of HBV proteins and the

production of virions. To test the efficacy of differencing base pair composition siNAs targeted against HBV RNA, the siNA duplexes targeting site 263 within HBV pregenomic RNA were co-transfected with HBV genomic DNA once at 25 nM with lipid at 12.5 ug/ml into Hep G2 cells, and the subsequent levels of HBV RNA analyzed by RT PCR as compared to cells treated with an inverted siNA control to site 263 and untreated cells. Results are summarized in **Figure 117**. As shown in the figure, the siNA constructs with 16, 17, and 18 base pairs within a 21 nucleotide construct were all efficacious in inhibiting HBV RNA in this system, whereas the corresponding 16, 17, and 18 base pair constructs with an overall length of 18, 19, and 20 nucleotides respectively were also efficacious, but to a lesser extent. As such, this data suggests that the overall length of a siNA can be more determinative in providing RNAi efficacy than the absolute number of base paired nucleotides. For example, a siNA having fewer than 19 base pairs (e.g. 18, 17, or 16 base pairs) within a longer oligonucleotide (e.g. 20 or more nucleotides) can still be effective in mediating RNA interference.

All patents and publications mentioned in the specification are indicative of the levels of skill of those skilled in the art to which the invention pertains. All references cited in this disclosure are incorporated by reference to the same extent as if each reference had been incorporated by reference in its entirety individually.

One skilled in the art would readily appreciate that the present invention is well adapted to carry out the objects and obtain the ends and advantages mentioned, as well as those inherent therein. The methods and compositions described herein as presently representative of preferred embodiments are exemplary and are not intended as limitations on the scope of the invention. Changes therein and other uses will occur to those skilled in the art, which are encompassed within the spirit of the invention, are defined by the scope of the claims.

It will be readily apparent to one skilled in the art that varying substitutions and modifications can be made to the invention disclosed herein without departing from the scope and spirit of the invention. Thus, such additional embodiments are within the scope of the present invention and the following claims. The present invention teaches one skilled in the art to test various combinations and/or substitutions of chemical modifications described herein toward generating nucleic acid constructs with improved

activity for mediating RNAi activity. Such improved activity can comprise improved stability, improved bioavailability, and/or improved activation of cellular responses mediating RNAi. Therefore, the specific embodiments described herein are not limiting and one skilled in the art can readily appreciate that specific combinations of the modifications described herein can be tested without undue experimentation toward identifying siNA molecules with improved RNAi activity.

The invention illustratively described herein suitably can be practiced in the absence of any element or elements, limitation or limitations that are not specifically disclosed herein. Thus, for example, in each instance herein any of the terms "comprising", "consisting essentially of", and "consisting of" may be replaced with either of the other two terms. The terms and expressions which have been employed are used as terms of description and not of limitation, and there is no intention that in the use of such terms and expressions of excluding any equivalents of the features shown and described or portions thereof, but it is recognized that various modifications are possible within the scope of the invention claimed. Thus, it should be understood that although the present invention has been specifically disclosed by preferred embodiments, optional features, modification and variation of the concepts herein disclosed may be resorted to by those skilled in the art, and that such modifications and variations are considered to be within the scope of this invention as defined by the description and the appended claims.

In addition, where features or aspects of the invention are described in terms of Markush groups or other grouping of alternatives, those skilled in the art will recognize that the invention is also thereby described in terms of any individual member or subgroup of members of the Markush group or other group.



MBHB 03-465-E; (400/160)

Table I

Sirma/RPI#	Aliases	Sequence	SEQ ID#
25227	Sirma/RPI 21550 EGFR 3830L23 AS as siNA Str 1 (sense)	B UAACCUUGUACUGGUGCCUCC B	1
25228	Sirma/RPI 21550 EGFR 3830L23 AS as siNA Str 2 (antisense)	B GGAGGCACCAGUACGAGGUUA B	2
25229	Sirma/RPI 21549 EGFR as siNA Str 2 (antisense)	B AAACUCCAAAGAUCCCAAUCA B	3
25230	Sirma/RPI 21549 EGFR 3 as siNA Str 1 (sense)	B UGAUUGGGGAUCUUGGAGUUU B	4
25231	Sirma/RPI 21547EGFR as siNA Str 2 (antisense)	B GUUGGAGUCUGUAGGACUUGG B	5
25232	Sirma/RPI 21547EGFR as siNA Str 1 (sense)	B CCAAGUCCUACAGACUCCAAC B	6
25233	Sirma/RPI 21545 EGFR as siNA Str 2 (antisense)	B GCAAAAACCCUGUGAUUCCU B	7
25234	Sirma/RPI 21545 EGFR as siNA Str 1 (sense)	B AGGAAUACACAGGGUUUUUUGC B	8
25235	Sirma/RPI 21543 EGFR as siNA Str 2 (antisense)	B UUGGUCAGUUUCUGGCAGUUC B	9
25236	Sirma/RPI 21543 EGFR as siNA Str 1 (sense)	B GAACUGCCAGAAACUGACCAA B	10
25237	HCV IRES Loop IIIb (Heptazyme site) as siNA str1 (sense) HCV IRES Loop IIIb (Heptazyme site) as siNA str2 (antisense)	B GGUCCUUUCUUGGAUCAACC B	11
25238	HBV (HepBzyme site) as siNA str1(sense)	B GGGUUGAUCCAAGAAAGGACC B	12
25239	HBV (HepBzyme site) as siNA str2(antisense)	B UGGACUUCUCUCAUUUUCUA B	13
25240	HBV (HepBzyme site) as siNA str2 (antisense)	B UAGAAAUUUGAGAGAAGUCCA B	14
25241	HBV18371 site as siNA str1(sense)	B UUUUUCACCUCUGCCUAAUCA B	15
25242	HBV18371 site as siNA str2 (antisense)	B UGAUUAGGCAGAGGUGAAAAA B	16
25243	HBV16372-18373 site as siNA str1(sense)	B CAAGCCUCCAAGCUGUGCCUU B	17
25244	HBV16372-18373 site as siNA str 2 (antisense)	B AAGGCACAGCUUGGAGGCUUG B	18
25245	Sirma/RPI 17763 Her2Neu AS as siNA Str 2 (antisense)	B UCCAUGGUGCUCACUGCGGCU B	19
25246	Sirma/RPI 17763 Her2Neu AS as siNA Str 1 (sense)	B AGCCGCAGUGAGCACCACUUGGA B	20
25247	Inverted control	B AGGUACCACGAGUGACGCCGA B	21
25248	Sirma/RPI 17763 Her2Neu AS as siNA Str 1 (sense) Inverted control compliment	B UCGGCGUCACUCGUGGUACCU B	22
25249	Sirma/RPI 21550 EGFR 3830L23 AS as siNA Str 1 (sense) Inverted Control	B CCUCCGUGGUCAUGCUCCAUA B	23
25250	Sirma/RPI 21550 EGFR 3830L23 AS as siNA Str 1 (sense) Inverted Control Compliment	B AUUGGAGCAUGACCACGGAGG B	24
25251	HCV IRES Loop IIIb (Heptazyme site) as siNA str1 (sense) Inverted Control	B CCCAACUAGGUUCUUCUUGG B	25

MBHB 03-465-E; (400/160)

25252	HCV IRES Loop IIb (Heptazyme site) as siNA str1 (sense) Inverted Control Complement	B CCAGGAAAGAACCUAGUUGGG B	26
25804	Sirna/RPI 21550 EGFR 3830L23 AS as siNA Str 1 (sense) +2U overhang	UAACCUAGUACUGGUCUCCUUU	27
25805	Sirna/RPI 21550 EGFR 3830L23 AS as siNA Str 2 (antisense) +2U overhang	GGAGGCCACCAGUACGAGGUUUUU	28
25806	Sirna/RPI 21549 EGFR as siNA Str 2 (antisense)+ 2U overhang	AAACUCCAAGAUCUCCCCAAUCAUU	29
25824	Sirna/RPI 21550 EGFR 3830L23 AS as siNA Str 1 (sense) +2U overhang	BUAACUCUGUACUGGUGCCUCCUUUB	30
25825	Sirna/RPI 21550 EGFR 3830L23 AS as siNA Str 2 (antisense) +2U overhang	BGGAGGCCACCAGUACGAGGUUUUUUB	31
25826	Sirna/RPI 21549 EGFR as siNA Str 2 (antisense)+ 2U overhang	BAAACUCCAAGAUCUCCCCAAUCAUUUB	32
25807	Sirna/RPI 21549 EGFR 3 as siNA Str 1 (sense)+2U overhang	UGAUUGGGGAUCUUGGAGUUUUU	33
25808	Sirna/RPI 21547EGFR as siNA Str 2 (antisense) +2U overhang	GUUGGAGUCUGUAGGACUUGGUU	34
25809	Sirna/RPI 21547EGFR as siNA Str 1 (sense) + 2U overhang	CCAAGUCCUACAGACUCCAAACUUU	35
25827	Sirna/RPI 21549 EGFR 3 as siNA Str 1 (sense)+2U overhang	BUGAUUGGGGAUCUUGGAGUUUUUUB	36
25828	Sirna/RPI 21547EGFR as siNA Str 2 (antisense) +2U overhang	BGUUGGAGUCUGUAGGACUUGGUUUB	37
25829	Sirna/RPI 21547EGFR as siNA Str 1 (sense) + 2U overhang	BCAAGUCCUACAGACUCCAAACUUB	38
25810	Sirna/RPI 21545 EGFR as siNA Str 2 (antisense)+2U overhang	GCAAAAACCCUGUGAUUUUCCUUU	39
25811	Sirna/RPI 21545 EGFR as siNA Str 1 (sense)+2U overhang	AGGAAAUACACAGGGGUUUUUUGCUU	40
25812	Sirna/RPI 21543 EGFR as siNA Str 2 (antisense)+2U overhang	UUUGGUAGUUUCUUGGCAGUUUCUU	41
25830	Sirna/RPI 21545 EGFR as siNA Str 2 (antisense)+2U overhang	BGCAAAAACCCUGUGAUUUUCCUUUB	42
25831	Sirna/RPI 21545 EGFR as siNA Str 1 (sense)+2U overhang	BAGGAAAUACACAGGGUUUUUUGCUUB	43
25832	Sirna/RPI 21543 EGFR as siNA Str 2 (antisense)+2U overhang	BUUGGUACAGUUUCUUGGCAGUUUCUUB	44
25813	Sirna/RPI 21543 EGFR as siNA Str 1 (sense)+2U overhang	GAACUGCCAGAAACUCAGACCAAUU	45
25814	HCV IRES Loop IIb (Heptazyme site) as siNA str1 (sense)+2U overhang	GGUCCUUUCUUGGUAUCAACCCUUU	46
25815	HCV IRES Loop IIb (Heptazyme site) as siNA str2 (antisense) +2U overhang	GGGUUGAUCCAAGAAAGGACCUU	47
25833	Sirna/RPI 21543 EGFR as siNA Str 1 (sense)+2U	BGAACUGCCAGAAACUCAGACCAAUUB	48

MBHB 03-465-E; (400/160)

25834	overhang HCV IRES Loop IIIb (Heptazyme site) as siNA str1 (sense)+2U overhang	BGGUCCUUUCUUGGAUCAACCCUUB	49
25835	HCV IRES Loop IIIb (Heptazyme site) as siNA str2 (antisense) +2U overhang	BGGGUUGAUCCCAAGAAAGGACCUUB	50
25816	HBV (HepBzyme site) as siNA str1 (sense)+2U overhang HBV (HepBzyme site) as siNA str2 (antisense)+2U overhang	UGGACUUCUCUCAUUUUUCUAUU	51
25817	HBV18371 site as siNA str1 (sense)+2U overhang	UAGAAAAUUUGAGAGAAGUCCAUU	52
25818	HBV (HepBzyme site) as siNA str1 (sense)+2U overhang	UUUUUCACCUUCUGCCUAUUAUU	53
25836	HBV (HepBzyme site) as siNA str2 (antisense)+2U overhang	BUGGACUUCUCUCAUUUUUCUAUUB	54
25837	HBV18371 site as siNA str1 (sense)+2U overhang	BUAGAAAAUUUGAGAGAAGUCCAUUB	55
25838	HBV18371 site as siNA str2 (antisense)+2U overhang	BUUUUUCACCUUCUGCCUAUUAUUB	56
25819	HBV16372-18373 site as siNA str1 (sense)+2U overhang	UGAUUAGGCAGAGGUGAAAAUUU	57
25820	HBV16372-18373 site as siNA str2 (antisense)+2U overhang	CAAGCCUCCAAAGCUGUGCCUUUUU	58
25821	HBV18371 site as siNA str1 (sense)+2U overhang	AAGGCACAGCUUGGAGGCUUGUU	59
25839	HBV18371 site as siNA str2 (antisense)+2U overhang	BUGAUUAGGCAGAGGUGAAAAUUUB	60
25840	HBV16372-18373 site as siNA str1 (sense)+2U overhang	BCAAGCCUCCAAAGCUGUGCCUUUUUB	61
25841	HBV16372-18373 site as siNA str2 (antisense)+2U overhang	BAAGGCACAGCUUGGAGGCUUGUUB	62
25822	Sima/RPI 17763 Her2Neu AS as siNA Str 2 (antisense)+2U overhang	UCCAUGGUJGUCACUGCGGCUUUU	63
25823	Sima/RPI 17763 Her2Neu AS as siNA Str 1 (sense)+2U overhang	AGCCGCAGUGAGCACCAUUGGAUU	64
25842	Sima/RPI 17763 Her2Neu AS as siNA Str 2 (antisense)+2U overhang	BUCCAUGGUJGUCACUGCGGCUUUUB	65
25843	Sima/RPI 17763 Her2Neu AS as siNA Str 1 (sense)+2U overhang	BAGCCGCAGUGAGCACCAUUGGAUUB	66
27649	Sima/RPI GL2 Str1 (sense)	CGUACGGCGGAUAUCUUCGA TT	67
27650	Sima/RPI GL2 Str2 (antisense)	UCGAAGUJUUCGCGGUACG TT	68
27651	Sima/RPI Inverted GL2 Str1 (sense)	AGCUUCAUAAGGCGCAUGC TT	69
27652	Sima/RPI Inverted GL2 Str2 (antisense)	GCAUGCGCCUUAUGAAGCU TT	70
27653	Sima/RPI GL2 Str1 (sense) all ribo P=S	CsGsUsAsCsGsCsGsAsUsAsCsUsUsCsGsA TT	71
27654	Sima/RPI GL2 Str1 (sense) all ribo pyrimidines P=S	CsGUsACsGCGGAUUsCsUsUsCsGA TT	72
27655	Sima/RPI GL2 Str1 (sense) 14' 5' P=S	CsGsUsAsCsGsCsGsAsUsAsCsUUCGA TT	73
27656	Sima/RPI GL2 Str1 (sense) 10' 5' P=S	CsGsUsAsCsGsCsGsAsAUUCUUCGA TT	74
27657	Sima/RPI GL2 Str1 (sense) 5' 5' P=S	CsGsUsAsCsGCGGAUUAUCUUCGA TT	75
27658	Sima/RPI GL2 Str2 (antisense) all ribo P=S	UsCsGsAsAsGsUsUsUsCsCsGsCsGsUsAsCsG TT	76
27659	Sima/RPI GL2 Str2 (antisense) all ribo pyrimidines P=S	UsCsGAAGUUsUsUsCsCsGCGUsACsG TT	77
27660	Sima/RPI GL2 Str2 (antisense) 5' 14 P=S	UsCsGsAsAsGUsAsUsUsCsCsGsCsGUACG TT	78

MBHB 03-465-E; (400/160)

27661	Sima/RPI GL2 Str2 (antisense) 5' 10 P=S	UscsGsAsAsGsUsAsUsCcCGCUACG TT	79
27662	Sima/RPI GL2 Str2 (antisense) 5' 5 P=S	UscsGsAsAsGUAUUCGCGUACG TT	80
28010	Sima/RPI GL2 Str1 (sense) 5' ligation fragment	CGUACG	81
28011	Sima/RPI GL2 Str1 (sense) 3' ligation fragment	CGGAUACUUCGATT	82
28012	Sima/RPI GL2 Str2 (antisense) 5' ligation fragment	UUGAAGUA	83
28013	Sima/RPI GL2 Str2 (antisense) 3' ligation fragment	UCCGCGUACGTT	84
28254	Sima/RPI GL2 Str1 (sense) all pyrimidines + TT = PS	CsGUsAcGsGGAAUAcUsUsCsGATsT	85
28255	Sima/RPI GL2 Str2 (antisense), + TT = PS	UCGAAGUAUUCGCGUACGTT	86
28256	Sima/RPI GL2 Str2 (antisense), all pyrimidines+ TT = PS	UscsGAAGUsAUscsCsGsGUsAcCsGTsT	87
28262	Her2.1.sense Str1 (sense)	UGGGGUCGUCAAAGACGUUTT	88
28263	Her2.1.antisense Str2 (antisense)	AACGUCUUUGACGACCCCAT	89
28264	Her2.1.sense Str1 (sense) inverted	UUGCAGAAACUUGCGGGGUTT	90
28265	Her2.1.antisense Str2 (antisense) inverted	ACCCAGCAGUUUCUGCAATT	91
28266	Her2.2.sense Str1 (sense)	GGUGCUUGGAUCUGGCGCUTT	92
28267	Her2.2.antisense Str2 (antisense)	AGGCCAGAUCCAAAGCACCTT	93
28268	Her2.2.sense Str1 (sense) inverted	UCGCGGUCUAGGUUCGUGGTT	94
28269	Her2.2.antisense Str2 (antisense) inverted	CCACGAACCUAGACCCGCGATT	95
28270	Her2.3.sense Str1 (sense)	GAUCUUUGGGAGCCUGGCATT	96
28271	Her2.3.antisense Str2 (antisense)	UCCAGGCCUCCCAAGAUCTT	97
28272	Her2.3.sense Str1 (sense) inverted	ACGGUCGGAGGUUUCUJAGTT	98
28273	Her2.3.antisense Str2 (antisense) inverted	CUAGAAACCCUCCGGACCGUTT	99
28274	Sima/RPI Inverted GL2 Str1 (sense) all ribo pyrimidines P=S	AGCsUsCsAUscsAAGGCGCsAUscGc TT	100
28275	Sima/RPI Inverted GL2 Str2 (antisense) all ribo pyrimidines P=S	AsGsCsUsUsCAUAAGGCGCAUGC TT	101
28276	Sima/RPI Inverted GL2 Str2 (antisense) 5' 5' P=S	GCsAUscGcCsUsUsAUscGAAGCsU TT	102
28277	Sima/RPI Inverted GL2 Str2 (antisense) all ribo P=S	GsCsAsUsGsCGCCUUAUGAAGCU TT	103
28278	Sima/RPI Inverted GL2 Str2 (antisense) 14 5' P=S	GsCsAsUsGsCsGsCsUsUsAsUsGsAsAsGsCsU TT	104
28279	Sima/RPI Inverted GL2 Str2 (antisense) 10 5' P=S	GsCsAsUsGsCsGsCsUsUsAsUsGsAAAGCU TT	105
28280	hRelA.1.sense Str1 (sense)	GsCsAsUsGsCsGsCsUsUAUGAAGCU TT	106
28384	hRelA.1.antisense Str2 (antisense)	CAGCACAGACCCAGCUGUGTT	107
28385	hRelA.1.sense Str1 (sense) inverted	CACAGCUGGGUCUGUGCUGTT	108
28386	hRelA.1.antisense Str2 (antisense) inverted	GUGUCGACCCAGACACGACTT	109
28387	hRelA.2.sense Str1 (sense)	GUCGUGUCUGGGUCGACACTT	110
28388	hRelA.2.antisense Str2 (antisense)	GCAGGUCGGAGGUAAAGGCCTT	111
28389	hRelA.2.sense Str1 (sense) inverted	GGCCUUACCUCACCCUGCUGTT	112
28390	hRelA.2.antisense Str2 (antisense) inverted	CCGGAAUUGGAGGUUCGGACGTT	113
28391	h/mRelA.3.sense Str1 (sense)	CGUCCAGCCUCCAUUCGCGTT	114
		GACUUCUCCUCCAUUCGCGTT	115

MBHB 03-465-E; (400/160)

28392	h/mReiA.3.antisense Str2 (antisense)	CCGCAUUGGAGGAGGAGGAGUUCTT	116
28393	h/mReiA.3.sense Str1 (sense) inverted	GGCGUUAACCUCCUUCUUCAGTT	117
28394	h/mReiA.3.antisense Str2 (antisense) inverted	CUGAAGAGGAGGAGGUAACGCCTT	118
28395	h/mReiA.4.sense Str1 (sense)	CACUGCCGAGCUCUACAAGAUUCTT	119
28396	h/mReiA.4.antisense Str2 (antisense)	GAUCUUGAGCUCGCGCAGUGTT	120
28397	h/mReiA.4.sense Str1 (sense) inverted	CUAGAACUCGAGCCGUCACACTT	121
28398	h/mReiA.4.antisense Str2 (antisense) inverted	GUGACGGCUCGAGUUCUAGTT	122
28399	hIKKg.1.sense Str1 (sense)	GGAGUUCUUCUAGUGCAAGTT	123
28400	hIKKg.1.antisense Str2 (antisense)	CUUGCACAUGAGGAAUCUCCCTT	124
28401	hIKKg.1.sense Str1 (sense) inverted	GAACGUGUACUCCUUGAGGTT	125
28402	hIKKg.1.antisense Str2 (antisense) inverted	CCUCAAGGAGUACACGUJUCTT	126
28403	hIKKg.2.sense Str1 (sense)	UCAAGAGCUCGAGAGUJGCCTT	127
28404	hIKKg.2.antisense Str2 (antisense)	GGCAUCUCGGAGCUCUUGATT	128
28405	hIKKg.2.sense Str1 (sense) inverted	CCGUAGAGCCUCGAGAACTT	129
28406	hIKKg.2.antisense Str2 (antisense) inverted	AGUUCUGGAGCCUCUJACGGTT	130
28407	h/mIKKG.sense Str1 (sense)	GCAGAUGGCUGAGGACAAGTT	131
28408	h/mIKKG.3.antisense Str2 (antisense)	CUUGUCCUCAGCCAUJUGCTT	132
28409	h/mIKKG.3.sense Str1 (sense) inverted	GAACAGGAGUCGGUJAGACGTT	133
28410	h/mIKKG.3.antisense Str2 (antisense) inverted	CGUCUACCGACUCCUUGUUCTT	134
28447	Sima/RPI construct as hairpin +GAAA+AU blunt	AACGUACGCGGAAUACUUCGUAUAAAAGUAUUCGAAUAUUCGCGUACGUU	135
28448	Sima/RPI construct as hairpin +GAAA+AU 3' overhang	CGUACGCGGAAUACUUCGUAUAAAAGUAUUCGAAUAUUCGCGUACGUU	136
28449	Sima/RPI construct as hairpin +GAAA blunt	AACGUACGCGGAAUACUUCGUAUAAAAGUAUUCGAAUAUUCGCGUACGUU	137
28450	Sima/RPI construct as hairpin +GAAA 3' overhang	CGUACGCGGAAUACUUCGUAUAAAAGUAUUCGAAUAUUCGCGUACGUU	138
28451	Sima/RPI construct as hairpin +UUG 3' overhang	CGUACGCGGAAUACUUCGUAUAAAAGUAUUCGAAUAUUCGCGUACGUU	139
28452	Sima/RPI construct as hairpin +UUG blunt	AACGUACGCGGAAUACUUCGUAUAAAAGUAUUCGAAUAUUCGCGUACGUU	140
28453	Sima/RPI construct as hairpin +UUG+AU blunt	AACGUACGCGGAAUACUUCGUAUAAAAGUAUUCGAAUAUUCGCGUACGUU	141
28454	Sima/RPI construct as hairpin +UUG 3' overhang	CGUACGCGGAAUACUUCGUAUAAAAGUAUUCGAAUAUUCGCGUACGUU	142
28415	HCV-Luc:325U21 TT siNA (sense)	CCCCGGGAGGUCUCGUAGATT	143
28416	HCV-Luc:162U21 TT siNA (sense)	CGGAACCCGGUGAGUACACCTT	144
28417	HCV-Luc:324U21 TT siNA (sense)	GCCCCGGGAGGUCUCGUAGTT	145
28418	HCV-Luc:163U21 TT siNA (sense)	GGAACCCGGUGAGUACACCGTT	146
28419	HCV-Luc:294U21 TT siNA (sense)	GUGGUACUGCCUGAUJAGGTT	147
28420	HCV-Luc:293U21 TT siNA (sense)	UGUGGUACUGCCUGAUJAGTT	148
28421	HCV-Luc:292U21 TT siNA (sense)	UUGUGGUACUGCCUGAUJAGTT	149
28422	HCV-Luc:343L21 TT siNA (325C) (antisense)	UCUACGAGACCUCCGGGGTT	150
28423	HCV-Luc:180L21 TT siNA (162C) (antisense)	GGUGUACUCACCCGGUJCCGTT	151
28424	HCV-Luc:342L21 TT siNA (324C) (antisense)	CUACGAGACCUCCGGGGCTT	152
28425	HCV-Luc:181L21 TT siNA (163C) (antisense)	CGGUGUACUCACCCGGUJCCCTT	153

MBHB 03-465-E; (400/160)

28426	HCV-Luc:312L21 TT siNA (294C) (antisense)	CCUUAUCAGGAGUACCACTT	154
28427	HCV-Luc:311L21 TT siNA (293C) (antisense)	CCUUAUCAGGAGUACCACTT	155
28428	HCV-Luc:310L21 TT siNA (292C) (antisense)	CUAUCAGGAGUACCAACTT	156
28429	HCV-Luc:325U21 TT siNA (sense) inv	TTAGAUGCUCUGGAGGGCCCC	157
28430	HCV-Luc:162U21 TT siNA (sense) inv	TTCCACAUGAGUGGCCAAGGC	158
28431	HCV-Luc:324U21 TT siNA (sense) inv	TTGAUCCUCUGGAGGGCCCCCG	159
28432	HCV-Luc:163U21 TT siNA (sense) inv	TTGCCACAUGAGUGGCCAAGG	160
28433	HCV-Luc:294U21 TT siNA (sense) inv	TTGGGAUAGUCCGUCUAUGGUG	161
28434	HCV-Luc:293U21 TT siNA (sense) inv	TTGGGAUAGUCCGUCUAUGGUGU	162
28435	HCV-Luc:292U21 TT siNA (sense) inv	TTGAUAGUCCGUCUAUGGUGUU	163
28436	HCV-Luc:343L21 TT siNA (325C) (antisense) inv	TTGGGGCCCCUCCAGAGCAUCU	164
28437	HCV-Luc:180L21 TT siNA (162C) (antisense) inv	TTGCCUUUGGCCACUCUAUGUGG	165
28438	HCV-Luc:342L21 TT siNA (324C) (antisense) inv	TTGGGGCCCCUCCAGAGCAUC	166
28439	HCV-Luc:181L21 TT siNA (163C) (antisense) inv	TTCCUUUGGCCACUCUAUGUGG	167
28440	HCV-Luc:312L21 TT siNA (294C) (antisense) inv	TTCCACAUGAGGACUAUCCC	168
28441	HCV-Luc:311L21 TT siNA (293C) (antisense) inv	TTACACCAUGACGGACUAUCC	169
28442	HCV-Luc:310L21 TT siNA (292C) (antisense) inv	TTAACACCAUGACGGACUAUCC	170
28458	Sima/RPI Inverted GL2 Str1 (sense) 5' P=S + TsT	AsGsCsUsUsCAUAAAGGGCGCAUGC TsT	171
28459	Sima/RPI Inverted GL2 Str2 (antisense) 5' P=S + TsT	GsCsAsUsGsCGCCUUUAUGAAGCU TsT	172
28460	Sima/RPI GL2 Str1 (sense) 5' P=S + TsT	CsGsUsAsCsGCGGAUJACUUCGA TsT	173
28461	Sima/RPI GL2 Str2 (antisense) 5' P=S + TsT	UsCsGsAsAsGUUAUUCGCGUACG TsT	174
28511	Sima/RPI GL2 Str2 (antisense) + Sima/RPI GL2 Str1 (sense) (tandem synth. w/ IdB on 3' of Str 1)	CGUACGGGAUAUCUUCGATTBUCGAAGUAUUCGCGUACG TT	175
29543	HBV:248U21 siNA pos (sense)	GUCUAGACUCUGGUGGACTT	176
29544	HBV:414U21 siNA pos (sense)	CCUGCUGCUAUGCUCUAUCTT	177
29545	HBV:1867U21 siNA pos (sense)	CAAGCCUCCAAAGCUGUGCCCTT	178
29546	HBV:1877U21 siNA pos (sense)	AGCUGUGCCUJGGGUGGCCUTT	179
29547	HBV:228L21 siNA neg (248C) (antisense)	GUCCACCACGAGUCUAGACTT	180
29548	HBV:394L21 siNA neg (414C) (antisense)	GAUGAGGCAUAGCAGCAGGTT	181
29549	HBV:1847L21 siNA neg (1867C) (antisense)	GGCACAGCUUGGAGGCUUGTT	182
29550	HBV:1857L21 siNA neg (1877C) (antisense)	AGCCACCACGAGCAGCUTT	183
29551	HBV:248U21 siNA pos (sense) inv	CAGGUGGUCUCAGAUUGTT	184
29552	HBV:414U21 siNA pos (sense) inv	CUACUCCGUJUCGUCUCCTT	185
29553	HBV:1867U21 siNA pos (sense) inv	CCGUGUCGAACCUCCGAACCTT	186
29554	HBV:1877U21 siNA pos (sense) inv	UCGGUGGUCUCCGUGUCGATT	187
29555	HBV:228L21 siNA neg (248C) (antisense) inv	CAGAUUCGAGCACCACCUUGTT	188
29556	HBV:394L21 siNA neg (414C) (antisense) inv	GGACGACGAUJACGGAGUAGTT	189
29557	HBV:1847L21 siNA neg (1867C) (antisense) inv	GUUCGGAGGUUCGACACGGTT	190

MBHB 03-465-E; (400/160)

29568	HBV:1857L21 siNA neg (1877C) (antisense) inv	UCGACACGGAAACCCACCGATT	191
29573	HCV-Luc:162U21 siNA (sense)	CGGAACCCGGUGAGUACACCCGG	192
29574	HCV-Luc:163U21 siNA (sense)	GGAACCCGGUGAGUACACCCGGA	193
29575	HCV-Luc:292U21 siNA (sense)	UUGUGUACUCGCCUGAUAGGG	194
29576	HCV-Luc:293U21 siNA (sense)	UGUGUACUCGCCUGAUAGGGU	195
29577	HCV-Luc:294U21 siNA (sense)	GUGGUACUCGCCUGAUAGGGUG	196
29578	HCV-Luc:324U21 siNA (sense)	GCCCCGGAGGUCUCGUAGAC	197
29579	HCV-Luc:325U21 siNA (sense)	CCCCGGGAGGUCUCGUAGACC	198
29580	HCV-Luc:182L21 siNA (162C) (antisense)	GGUGUACUCACCCGGUUCCGCA	199
29581	HCV-Luc:183L21 siNA (163C) (antisense)	CGGUGUACUCACCCGGUUCCGC	200
29582	HCV-Luc:312L21 siNA (292C) (antisense)	CUJACAGGCAGUACCACAAG	201
29583	HCV-Luc:313L21 siNA (293C) (antisense)	CCUJACAGGCAGUACCACAAG	202
29584	HCV-Luc:314L21 siNA (294C) (antisense)	CCCJACAGGCAGUACCACAAG	203
29585	HCV-Luc:344L21 siNA (324C) (antisense)	CUJACAGGCAGUACCACAAG	204
29586	HCV-Luc:345L21 siNA (325C) (antisense)	UCUACGAGACCUCGCCGGGCA	205
29587	HCV-Luc:162U21 siNA (sense) rev	GGCCACAUAGAGUGGCCAAGGC	206
29588	HCV-Luc:163U21 siNA (sense) rev	AGGCCACAUAGAGUGGCCAAGG	207
29589	HCV-Luc:292U21 siNA (sense) rev	GGGAUAGUCCGUCUAUGGUGU	208
29590	HCV-Luc:293U21 siNA (sense) rev	UGGGUAGUCCGUCUAUGGUGU	209
29591	HCV-Luc:294U21 siNA (sense) rev	GUGGGUAGUCCGUCUAUGGUG	210
29592	HCV-Luc:324U21 siNA (sense) rev	CAGAUUCUCUGGAGGGGCCCCG	211
29593	HCV-Luc:325U21 siNA (sense) rev	CCAGAUUCUCUGGAGGGGCCCC	212
29594	HCV-Luc:182L21 siNA (162C) (antisense) rev	ACGCCUUGGCCACUCUAUGUGG	213
29595	HCV-Luc:183L21 siNA (163C) (antisense) rev	CGCCUUGGCCACUCUAUGUGGC	214
29596	HCV-Luc:312L21 siNA (292C) (antisense) rev	GGAACACCAUGACGGACUAUC	215
29597	HCV-Luc:313L21 siNA (293C) (antisense) rev	GAACACCAUGACGGACUAUCC	216
29598	HCV-Luc:314L21 siNA (294C) (antisense) rev	AACACCAUGACGGACUAUCCC	217
29599	HCV-Luc:344L21 siNA (324C) (antisense) rev	CACGGGGCCUCCAGAGCAUC	218
29600	HCV-Luc:345L21 siNA (325C) (antisense) rev	ACGGGGCCUCCAGAGCAUCU	219
29601	Luc2:128U21 siNA (sense)	CAGAUACAUUUCGAGGUGA	220
29602	Luc3:128U21 siNA (sense)	CAGAUACAUUUCGAGGUGG	221
29603	Luc2/3:128U21 TT siNA (sense)	CAGAUACAUUUCGAGGUTT	222
29604	Luc2/3:148L21 siNA (128C) (antisense)	ACCUCGAUUGUCAUCUGUA	223
29605	Luc2/3:148L21 TT siNA (128C) (antisense)	ACCUCGAUUGUCAUCUGTT	224
29606	Luc2/3:166U21 siNA (sense)	UACUUCGAAAUGUCCGGUUCGG	225
29607	Luc2/3:166U21 TT siNA (sense)	UACUUCGAAAUGUCCGGUUCTT	226
29608	Luc2:186L21 siNA (166C) (antisense)	GAACGGACAUUUCGAAGUAUU	227
29609	Luc3:186L21 siNA (166C) (antisense)	GAACGGACAUUUCGAAGUACU	228

MBHB 03-465-E; (400/160)

29610	Luc2/3:186L21 TT siNA (166C) (antisense)	GAACGGACAUUUCGAAGUATT	229
29611	Luc2/3:167U21 siNA (sense)	ACUUCGAAAUUGCCGUUCGGU	230
29612	Luc2/3:167U21 TT siNA (sense)	ACUUCGAAAUUGCCGUUCGTT	231
29613	Luc2:187L21 siNA (167C) (antisense)	CGAACGGACAUUUCGAAGUAU	232
29614	Luc3:187L21 siNA (167C) (antisense)	CGAACGGACAUUUCGAAGUAC	233
29615	Luc2/3:187L21 TT siNA (167C) (antisense)	CGAACGGACAUUUCGAAGUTT	234
29616	Luc2/3:652U21 siNA (sense)	AGAUUCUCGCAUUGCCAGAGAU	235
29617	Luc2/3:652U21 TT siNA (sense)	AGAUUCUCGCAUUGCCAGAGTT	236
29618	Luc2:672L21 siNA (652C) (antisense)	CUCUGGCAUUGCCGAAUCUGA	237
29619	Luc3:672L21 siNA (652C) (antisense)	CUCUGGCAUUGCCGAAUCUCA	238
29620	Luc2/3:672L21 TT siNA (652C) (antisense)	CUCUGGCAUUGCCGAAUCUTT	239
29621	Luc2/3:653U21 siNA (sense)	GAUUCUCGCAUUGCCAGAGAU	240
29622	Luc2/3:653U21 TT siNA (sense)	GAUUCUCGCAUUGCCAGAGATT	241
29623	Luc2:673L21 siNA (653C) (antisense)	UCUCUGGCAUUGCCGAAUCUG	242
29624	Luc3:673L21 siNA (653C) (antisense)	UCUCUGGCAUUGCCGAAUCUC	243
29625	Luc2/3:673L21 TT siNA (653C) (antisense)	UCUCUGGCAUUGCCGAAUCUTT	244
29626	Luc2/3:880U21 siNA (sense)	UUCUUCGCCAAAAGCACUCUG	245
29627	Luc2/3:880U21 TT siNA (sense)	UUCUUCGCCAAAAGCACUCTT	246
29628	Luc2:900L21 siNA (880C) (antisense)	GAGUGCUUUUUGGCCGAAAGAU	247
29629	Luc3:900L21 siNA (880C) (antisense)	GAGUGCUUUUUGGCCGAAAGAG	248
29630	Luc2/3:900L21 TT siNA (880C) (antisense)	GAGUGCUUUUUGGCCGAAAGATT	249
29631	Luc2/3:1012U21 siNA (sense)	CAAGGAUUGGGCUCACUCAG	250
29632	Luc2/3:1012U21 TT siNA (sense)	CAAGGAUUGGGCUCACUGTT	251
29633	Luc2:1032L21 siNA (1012C) (antisense)	CAGUGAGCCCAUUCUUUGUC	252
29634	Luc3:1032L21 siNA (1012C) (antisense)	CAGUGAGCCCAUUCUUUGCC	253
29635	Luc2/3:1032L21 TT siNA (1012C) (antisense)	CAGUGAGCCCAUUCUUUGTT	254
29636	Luc2:1139U21 siNA (sense)	AAACGCGUGGGCGUUAAUCAGA	255
29637	Luc3:1139U21 siNA (sense)	AAACGCGUGGGCGUUAAUCAAA	256
29638	Luc2/3:1139U21 TT siNA (sense)	AAACGCGUGGGCGUUAAUCATT	257
29639	Luc2/3:1159L21 siNA (1139C) (antisense)	UGAUUAACGCCCCAGCGUUUUC	258
29640	Luc2/3:1159L21 TT siNA (1139C) (antisense)	UGAUUAACGCCCCAGCGUUUTT	259
29641	Luc2:1283U21 siNA (sense)	AAGACGAACACUUCUUAUJAG	260
29642	Luc3:1283U21 siNA (sense)	AAGACGAACACUUCUUAUCAUG	261
29643	Luc2/3:1283U21 TT siNA (sense)	AAGACGAACACUUCUUAUCAUTT	262
29644	Luc2/3:1303L21 siNA (1283C) (antisense)	AUGAAGAAGUGUUCGUCUUCG	263
29645	Luc2/3:1303L21 TT siNA (1283C) (antisense)	AUGAAGAAGUGUUCGUCUUTT	264
29646	Luc2:1487U21 siNA (sense)	AAGAGAUUCGUGGAAUJACGUGG	265
29647	Luc3:1487U21 siNA (sense)	AAGAGAUUCGUGGAAUJACGUCG	266



MBHB 03-465-E; (400/160)

29648	Luc2/3:1487U21 TT siNA (sense)	AAGAGAUcGUGGAUuACGGUtt	267
29649	Luc2/3:1507L21 siNA (1487C) (antisense)	ACGUAAUcCACGAUCUCUUUU	268
29650	Luc2/3:1507L21 TT siNA (1487C) (antisense)	ACGUAAUcCACGAUCUCUUtT	269
29651	Luc2:1622U21 siNA (sense)	AGCCCAAGAAAGGGCGGAAAGU	270
29652	Luc3:1622U21 siNA (sense)	AGCCCAAGAAAGGGCGGAAAGA	271
29653	Luc2/3:1622U21 TT siNA (sense)	AGCCCAAGAAAGGGCGGAAAtT	272
29654	Luc2/3:1642L21 siNA (1622C) (antisense)	UUUcCGCCCUUCUUGGcCUUU	273
29655	Luc2/3:1642L21 TT siNA (1622C) (antisense)	UUUcCGCCCUUCUUGGcCUtT	274
29656	Luc2:1623U21 siNA (sense)	GGCCAAAGAAAGGGCGGAAAGUC	275
29657	Luc3:1623U21 siNA (sense)	GGCCAAAGAAAGGGCGGAAAGAU	276
29658	Luc2/3:1623U21 TT siNA (sense)	GGCCAAAGAAAGGGCGGAAAGtT	277
29659	Luc2/3:1643L21 siNA (1623C) (antisense)	CUUUCcCGCCCUUCUUGGcCUU	278
29660	Luc2/3:1643L21 TT siNA (1623C) (antisense)	CUUUCcCGCCCUUCUUGGcCtT	279
29663	SimA/RPI GL2 Str2 (antisense), all pyrimidines + 5BrdUT = PS	UscsGAAGUscAUscCsCsGCsGUscACsGUst	280
29664	SimA/RPI GL2 Str1 (sense) all pyrimidines + 5-BrdUT = PS	CsGUscACsGCsGGAUscACsUscCsGAUst	281
29665	SimA/RPI GL2 Str1 (sense) 5' 5' +5-BrdUT = P=S	CsGsUscAsCsGCGGAAUcUUCGA Ust	282
29666	SimA/RPI GL2 Str2 (antisense) 5' 5' +5BrdUT = P=S	UscCsGsAsAsGUUUCcCGGUACG Ust	283
29667	PS+3'invAba		
29668	SimA/RPI GL2 Str1 (sense) all pyrimidines = PS+3' and 5' invAba	CsGUscACsGCsGGAUscACsUscCsGATsTB	284
29669	SimA/RPI GL2 Str1 (sense) all pyrimidines + TT = PS+ 5' invAba	BCsGUscACsGCsGGAUscACsUscCsGATsTB	285
29670	SimA/RPI GL2 Str2 (antisense), all pyrimidines + TT = PS + 3'inverted abasic	BCsGUscACsGCsGGAUscACsUscCsGATsT	286
29671	SimA/RPI GL2 Str2 (antisense), all pyrimidines + TT = PS + 3'and 5' inverted abasic	UscCsGAAGUscAUscCsCsGCsGUscACsGTsTB	287
29672	SimA/RPI GL2 Str2 (antisense), all pyrimidines + TT = PS + 5' inverted abasic	BUscCsGAAGUscAUscCsCsGCsGUscACsGTsTB	288
29678	SimA/RPI GL2 Str1 (sense) + SimA/RPI GL2 Str2 (antisense) (tandem synth. w/ idB on 3' of Str 2)	BUscCsGAAGUscAUscCsCsGCsGUscACsGTsT	289
29681	SimA/RPI GL2 Str1 (sense) 5'ligation fragment 5-5'-P=S	UCGAAGUUcCGGUACG TTBCGUACGGGAAUcUUCGAtT	290
29682	SimA/RPI GL2 Str1 (sense) 3'-ligation fragment 5-5'-P=S	CsGsUscAsCsG	291
29683	SimA/RPI GL2 Str2 (antisense) 5' ligation fragment 5-5'-P=S	CGGAAUcUUCGAtsT	292
29684	SimA/RPI GL2 Str2 (antisense) 3' ligation fragment 5-5'-P=S	UscCsGsAsAsGUA	293
29685	SimA/RPI GL2 Str2 (antisense) 5' ligation fragment all-P=S	UUcCGGUACGtT	294
29686	SimA/RPI GL2 Str2 (antisense) 3' ligation fragment all-P=S	UscCsGsAsAsGsUsA	295
29694	FLT1-349U21 siNA stab1 (sense)	UscCsCsGCsCsGUscAsCsGsTsT	296
		CsUscGsAsGsUUUAAAAGGCACCCtT	297

MIBHB 03-465-E; (400/160)

29695	FLT1:2340U21 siNA stab1 (sense)	CsAsAsCsCsACAAAUAACAACAATsT	298
29696	FLT1:3912U21 siNA stab1 (sense)	CsCsUsGsGsAAAGAAUAACAACCTsT	299
29697	FLT1:2949U21 siNA stab1 (sense)	GsCsAsAsGsGAGGGCCUCUGAUGTsT	300
29698	FLT1:369L21 siNA (349C) stab1 (antisense)	GsGsUsGsGCCUUUUAAAACUCAGTsT	301
29699	FLT1:2360L21 siNA (2340C) stab1 (antisense)	UsUsGsUsUsGUUUUUUUUGGUUGTsT	302
29700	FLT1:3932L21 siNA (3912C) stab1 (antisense)	GsGsUsUsUsUGAUUCUUUCCAGGTsT	303
29701	FLT1:2969L21 siNA (2949C) stab1 (antisense)	CsAsUsCsAsGAGGGCCUCUUUGCTsT	304
29706	FLT1:369L21 siNA (349C) (antisense) stab2	GsGsUsUsGsCsCsUsUsUsAsAsCsUsCsAsGsTsT	305
29707	FLT1:2360L21 siNA (2340C) (antisense) stab2	UsUsGsUsUsGsUsAsUsUsUsGsUsGsTsT	306
29708	FLT1:3932L21 siNA (3912C) (antisense) stab2	GsGsUsUsUsGsAsUsUsCsUsCsAsGsTsT	307
29709	FLT1:2969L21 siNA (2949C) (antisense) stab2	CsAsUsCsAsGsGsCsCsUsCsCsUsUsGsCsTsT	308
28030	Sima/RPI GL2 Str1 (sense)	ggcauuggccaacgUacggggaauacuucgguuacgaa	309
28242	Sima/RPI GL2 Str1 (sense) 2'-O-Me	cguacgcggaaUacuuucgaaU	310
28243	Sima/RPI GL2 Str1 (sense) 14' 5' 2'-O-Me	cguacgcggaaUacUUCGATT	311
28244	Sima/RPI GL2 Str1 (sense) 10' 5' 2'-O-Me	cguacgcggaaUACUUCGATT	312
28245	Sima/RPI GL2 Str1 (sense) 5' 5' 2'-O-Me	cguacGCGAAUACUUCGATT	313
28246	Sima/RPI GL2 Str2 (antisense) all 2'-O-me	ucgaaguauuuccgguacguu	314
28247	Sima/RPI GL2 Str2 (antisense) all ribo pyrimidines = 2'-O-Me	ucGAAGuAuuccGcGuAcGuu	315
28248	Sima/RPI GL2 Str2 (antisense) 5' 14' 2'-O-Me	ucgaaguauuuccgcGUACGTT	316
28249	Sima/RPI GL2 Str2 (antisense) 5' 10' 2'-O-Me	ucgaaguauuCCGCGUACGTT	317
28250	Sima/RPI GL2 Str2 (antisense) 5' 2'-O-Me	ucgaaGUAUUCCGCGUACGTT	318
28251	Sima/RPI GL2 Str1 (sense) all pyrimidines 2'-O-Me except 3'-TT	cGuAcGcGGAuAcuucGATT	319
28252	Sima/RPI GL2 Str1 (sense) all pyrimidines = 2'-O-Me	cGuAcGcGGAuAcuucGAuu	320
28253	Sima/RPI GL2 Str1 (sense)+ TT =P=S	CGUACGCGGAAUACUUCGATsT	321
28261	Sima/RPI GL2 Str2 (antisense) all ribo pyrimidines = 2'-O-me,except 3'-TT	ucGAAGuAuuccGcGuAcGTT	322
28257	Sima/RPI GL2 Str1 (sense)+ 3' univ. base 2	CGUACGCGGAAUACUUCGAXX	323
28258	Sima/RPI GL2 Str1 (sense)+ 3' univ base 1	CGUACGCGGAAUACUUCGAZZ	324
28259	Sima/RPI GL2 Str2 (antisense), + 3' univ. base 2	UCGAAGUUUCCGCGUACGXX	325
28260	Sima/RPI GL2 Str2 (antisense), + 3' univ. base 1	UCGAAGUUUCCGCGUACGZZ	326
28014	Sima/RPI GL2 Str1 (sense) 5'ligation fragment P=Scapped Y-2'F	csGsUsAscG	327
28015	Sima/RPI GL2 Str1 (sense) 3' ligation fragment P=Scapped Y-2'F	cGGAAuAcuucGsAsTsT	328
28026	Sima/RPI GL2 Str1 (sense)P=Scapped Y-2'F	csGsUsAscGcGGAAuAcuucGsAsTsT	329
28016	Sima/RPI GL2 Str2 (antisense) 5' ligation fragment P=Scapped Y-2'F	uscGsAsAGuA	330
28017	Sima/RPI GL2 Str2 (antisense) 3' ligation fragment	uuucGcGuAcscGsTsT	331

MBHB 03-465-E; (400/160)

28027	P=Scapped Y-2'F Sima/RPI GL2 Str2 (antisense) P=Scapped Y-2'F	uscsGsAsAGuAuuuccGCGuAscsGsTsT	332
28018	Sima/RPI GL2 Str1 (sense) 5'ligation fragment 5'P=S Y-2'F	scGuAcG	333
28019	Sima/RPI GL2 Str1 (sense) 3' ligation fragment 5'P=S Y-2'F	cGGAAuAuuucGATT	334
28028	Sima/RPI GL2 Str1 (sense) 5'P=S Y-2'F	scGuAcGcGGAuAuuucGATT	335
28020	Sima/RPI GL2 Str2 (antisense) 5' ligation fragment 5'P=S Y-2'F	sucGAAGuA	336
28021	Sima/RPI GL2 Str2 (antisense) 3'ligation fragment 5'P=S Y-2'F	uuuccGGGuAcGTT	337
28029	Sima/RPI GL2 Str2 (antisense) 5'P=S Y-2'F	sucGAAGuAuuuccGCGuAcGTT	338
28022	Sima/RPI Inverted GL2 Str1 (sense) P=Scapped Y-2'F	AsGscsusucAuAAGGcGcAuSgscsTsT	339
28023	Sima/RPI Inverted GL2 Str2 (antisense) P=Scapped Y-2'F	GscsAsusGcGccuuAuGAAgscsusTsT	340
28024	Sima/RPI Inverted GL2 Str1 (sense) 5'P=S Y-2'F	sAGcuucAuAAGGcGcAuGcTT	341
28025	Sima/RPI Inverted GL2 Str2 (antisense) 5'P=S Y-2'F	sGcAuGcGccuuAuGAAgcuTT	342
28455	Sima/RPI GL2 Str1 (sense) 2'-F U C	cGuAcGcGGAAuAuuucGATT	343
28456	Sima/RPI GL2 Str2 (antisense) 2'-F U C	ucGAAAGuAuuuccGcGuAcGTT	344
29702	FLT1:349U21 siNA stab3 (sense)	csusGsAsGuuuAAAGGcAcscscsTsT	345
29703	FLT1:2340U21 siNA stab3 (sense)	csAsAscscAcAAAuAcAcsAsAsTsT	346
29704	FLT1:3912U21 siNA stab3 (sense)	cscsusGsGAAAGAAuAcAAAascscsTsT	347
29705	FLT1:2949U21 siNA stab3 (sense)	GscsAsAsGGAGGGccucuGAsusGsTsT	348
28443	Sima/RPI GL2 Str1 (sense) 2'-amino U C	cGuAcGcGGAAuAuuucGATT	349
28444	Sima/RPI GL2 Str2 (antisense) 2'-amino U C	ucGAAAGuAuuuccGcGuAcGTT	350
28445	Sima/RPI GL2 Str1 (sense) 2'-amino U C uT 3'end	cGuAcGcGGAAuAuuucGAuT	351
28446	Sima/RPI GL2 Str2 (antisense) 2'-amino U C uT 3'end	ucGAAAGuAuuuccGcGuAcGuT	352
30051	HCV-Luc:325U21 siNA 5' P=S + 3' univ. base 2 + 5'/3' invAba (antisense)	BCsCsCsCsGsGGAGGUCUCGUAGAXXB	353
30052	HCV-Luc:325U21 siNA rev 5' P=S + 3' univ. base 2 + 5'/3' invAba (antisense)	BAsGsAsUsGsCUCUGGAGGGCCCCXXB	354
30053	HCV-Luc:345L21 siNA (325C) (antisense) 5' P=S + 3' univ. base 2 + 3' invAba (sense)	UsCsUsAsCsGAGACUCCCCGGGGXXB	355
30054	HCV-Luc:345L21 siNA (325C) (antisense) rev 5' P=S + 3' univ. base 2 + 3' invAba (sense)	GsGsGsGsCsCUCcCAGAGCAUCUXXB	356
30055	HCV-Luc:325U21 siNA all Y P=S + 3' univ. base 2 + 5'/3' invAba (antisense)	BCsCsCsCsGGGAGGUsCsUsCsGUsAGAXXB	357
30056	HCV-Luc:325U21 siNA rev all Y P=S + 3' univ. base 2 + 5'/3' invAba (antisense)	BAGAUsgCsUsGGAGGGCsCsCsXXB	358
30057	HCV-Luc:345L21 siNA (325C) (antisense) all Y P=S + 3' univ. base 2 + 3' invAba (sense)	UsCsUsAcSgAGACsCsUsCsCsGGGGXXB	359
30058	HCV-Luc:345L21 siNA (325C) (antisense) rev all Y P=S + 3' univ. base 2 + 3' invAba (sense)	GGGGCsCsCsUsCsCsAGAGCsUsCsUsXXB	360

MBHB 03-465-E; (400/160)

30059	HCV-Luc:325U21 siNA 4/3 P=S ends + all Y-2'F + 3' univ. base 2 + 5'/3' invAba (antisense)	BcscscscGGGAGGucucGuAsGsAsXXB	361
30060	HCV-Luc:325U21 siNA rev 4/3 P=S ends + all Y-2'F + 3' univ. base 2 + 5'/3' invAba (antisense)	BAsgAsusGcuucGGAGGGccscscsXXB	362
30170	HCV-Luc:325U21 siNA all Y-2'F + 3' univ. base 2 + 5'/3' invAba (antisense)	B cccGGGGGucucGuAGAXX B	363
30171	HCV-Luc:325U21 siNA rev all Y-2'F + 3' univ. base 2 + 5'/3' invAba (antisense)	B AGAuGcuucGGAGGGccscsXX B	364
30172	HCV-Luc:345L21 siNA (325C) (antisense) all Y P=S + 3' univ. base 2 + 5'/3' invAba (antisense)	B UsCsUsCsGAGACsUsCsCsCsGGGGXX B	365
30173	HCV-Luc:345L21 siNA (325C) (antisense) all Y-2'F	ucucAcGAGAccucscGGGG	366
30174	HCV-Luc:345L21 siNA (325C) (antisense) rev all Y-2'F	GGGGccucAcGAGcAucu	367
30175	HCV-Luc:345L21 siNA (325C) (antisense) rev all Y-2'F + 3' univ. base 2	ucucAcGAGAccucscGGGGXX	368
30176	HCV-Luc:345L21 siNA (325C) (antisense) all Y-2'F + 3' univ. base 2 + 5'/3' iB	GGGGccucAcGAGcAucuXX	369
30177	HCV-Luc:325U21 siNA all Y P=S + 3' univ. base 2 + 3' invAba (sense)	B ucucAcGAGAccucscGGGGXX B	370
30178	Sima/RPI GL2 Str1 (sense) 2'-F U,C + 3', 5' abasic	CsCsCsCsGGGGUscUsCsGsUAGAXX B	371
30063	Sima/RPI GL2 Str1 (sense) Y 2'-O-Me with 3'-TT & 5'/3' iB	BcGuAcGcGGAAuAcuucGATTB	372
30222	Sima/RPI GL2 Str1 (sense) Y 2'-F U,C + 3', 5' abasic, A,G= 2'-O-Me	B cGuAcGcGGAAuAcuucGATT B	373
30224	Sima/RPI GL2 Str2 (antisense) 2'-F U,C + 3', 5' abasic, A,G= 2'-O-Me	ucGAAGuAuuccGcGuAcGTsT	374
30430	Sima/RPI GL2 Str1 (sense) 2'-F U,C + 3', 5' abasic, TT; 2'-O-Me-A,G	ucgaguuuuccgcuacgTsT	375
30431	Sima/RPI GL2 Str1 (sense) 2'-F U,C + 3', 5' abasic, TT; 2'-deoxy-A,G	BcguacgcuuucggaucucucgaTTB	376
30433	Sima/RPI GL2 Str2 (antisense) 2'-F U,C 3'-dTst	BcGuAcGcGGAAuAcuucGATTB	377
30550	Sima/RPI GL2 Str2 (antisense) 2'-F U,C 3'-glycerol.T	ucGAAGuAuuccGcGuAcGTst	378
30555	Sima/RPI GL2 Str2 (antisense) 2'-F U,C 3'-glycerol.2T	ucGAAGuAuuccGcGuAcGTL	379
30556	rev Sima/RPI GL2 Str1 (sense) Y 2'-O-Me with 3'-TT & 5'/3' iB	ucGAAGuAuuccGcGuAcGTTL	380
30226	rev Sima/RPI GL2 Str1 (sense) Y 2'-F with 3'-TT & 5'/3' iB	B AGcuucAuAAAGGcGuAcGTT B	381
30227	rev Sima/RPI GL2 Str2 (antisense) Y 2'-F & 3' TsT	B AGcuucAuAAAGGcGuAcGTT B	382
30229	Sima/RPI GL2 Str1 (sense) 2'-F U,C + 3', 5' Abasic, TT; 2'-O-Me-A,G;ribo core	GcAuGcGcuuAuGAAGcuTsT	383
30434	Sima/RPI GL2 Str1 (sense) 2'-F U,C + 3', 5' Abasic, TT; 2'-deoxyA,G;ribo core	BcguacgcuuucggaucucucgaTTB	384
30435	Sima/RPI GL2 Str2 (antisense) 2'-F U,C 3'-dTt	BcGuAcGcGGAAuAcuucGATTB	385
30546	Sima/RPI GL2 Str2 (antisense) 2'-F U,C 3'-dTt	ucGAAGuAuuccGcGuAcG3T	386
30551	Sima/RPI GL2 Str2 (antisense) 2'-F U,C dTddC	ucGAAGuAuuccGcGuAcGTTdC	387



MBHB 03-465-E; (400/160)

	(antisense)		
30287	HBV:1580U21 siRNA (sense)	UGUGCACUUCGCUUCACCCUCU	426
30298	HBV:1598L21 siRNA (1580C) (antisense)	AGGUGAAGCGAAGUGCACACCG	427
31335	HBV:1580U21 siRNA stab09 (sense)	B UGUGCACUUCGCUUCACCCUUTT B	428
31337	HBV:1598L21 siRNA (1580C) stab10 (antisense)	AGGUGAAGCGAAGUGCACACATsT	429
31456	HCVa:291U21 siRNA stab04 (sense)	B cuuGuGUuAcuGccuGAuATT B	430
31468	HCVa:309L21 siRNA (291C) stab05 (antisense)	uAucAGGcAGuAccAcAAAGTsT	431
31480	HCVa:291U21 siRNA inv stab04 (sense)	B AuAGuccGucAuGGuGuucTT B	432
31492	HCVa:309L21 siRNA (291C) inv stab05 (antisense)	GAACaccAuGACGGAcuAuTsT	433
31461	HCVa:300U21 siRNA stab04 (sense)	B cuGccuGAuAGGGuGcuuGTT B	434
31473	HCVa:318L21 siRNA (300C) stab05 (antisense)	cAAGcAccuAuAcAGGcAGTsT	435
31485	HCVa:300U21 siRNA inv stab04 (sense)	B GuucGuGGGAuAGuccGucTT B	436
31497	HCVa:318L21 siRNA (300C) inv stab05 (antisense)	GACGGAcuAucccAcGAActTsT	437
31463	HCVa:303U21 siRNA stab04 (sense)	B ccuGAuAGGGuGcuuGcGATT B	438
31475	HCVa:321L21 siRNA (303C) stab05 (antisense)	ucGcAAgAcccuAucAGGTsT	439
31487	HCVa:303U21 siRNA inv stab04 (sense)	B AGcGuucGuGGGAuAGuccTT B	440
31499	HCVa:321L21 siRNA (303C) inv stab05 (antisense)	GGAcuAucccAcGAACcGuTsT	441
31344	HCVa:325U21 siRNA stab07 (sense)	B ccccGGGAGGucucGuAGATT B	442
30562	HCVa:345L21 siRNA (325C) Y-2F, R-2OMe + TsT (antisense)	ucuAcGAGAcucccccGGGGTsT	443
31345	HCVa:325U21 siRNA inv stab07 (sense)	B AGAuGcuuGGAGGGccccTT B	444
31346	HCVa:343L21 siRNA (325C) inv stab08 (antisense)	GGGccccuccAGAcAucuTsT	445
31702	HCVa:326U21 siRNA stab07 (sense)	B cccGGGAGGucucGuAGAcTT B	446
31706	HCVa:344L21 siRNA (326C) stab08 (antisense)	GucuAcGAGAccucccccGGGTsT	447
31710	HCVa:326U21 siRNA inv stab07 (sense)	B cAGAuGcuuGGAGGGccccTT B	448
31714	HCVa:344L21 siRNA (326C) inv stab08 (antisense)	GGccccuccAGAcAucuGtsT	449
31703	HCVa:327U21 siRNA stab07 (sense)	B ccGGGAGGucucGuAGAcTT B	450
31707	HCVa:345L21 siRNA (327C) stab08 (antisense)	GGucuAcGAGAccucccccGGTsT	451
31711	HCVa:327U21 siRNA inv stab07 (sense)	B ccAGAuGcuuGGAGGGccccTT B	452
31715	HCVa:345L21 siRNA (327C) inv stab08 (antisense)	GGccccuccAGAcAucuGGTsT	453
31704	HCVa:328U21 siRNA stab07 (sense)	B cGGGAGGucucGuAGAcTT B	454
31708	HCVa:346L21 siRNA (328C) stab08 (antisense)	cGGucuAcGAGAccucccccGTsT	455
31712	HCVa:328U21 siRNA inv stab07 (sense)	B GccAGAuGcuuGGAGGGccccTT B	456
31716	HCVa:346L21 siRNA (328C) inv stab08 (antisense)	GccccuccAGAcAucuGGcTsT	457
31705	HCVa:329U21 siRNA stab07 (sense)	B GGGAGGucucGuAGAcTT B	458
31709	HCVa:347L21 siRNA (329C) stab08 (antisense)	AcGGucuAcGAGAccucccccTsT	459
31713	HCVa:329U21 siRNA inv stab07 (sense)	B uGccAGAuGcuuGGAGGGTT B	460
31717	HCVa:347L21 siRNA (329C) inv stab08 (antisense)	ccccuccAGAcAucuGGcATsT	461

MBHB 03-465-E; (400/160)

HCVa:327 siRNA 3'-classI 10bp	UCUCGUAGACCUUGGUUACGAGACCUCCCGGTT	462
HCVa:327 siRNA 3'-classI 8bp	UCGUAGACCUUGGUUACGAGACCUCCCGGTT	463
HCVa:327 siRNA 3'-classI 6bp	GUAGACCUUGGUUACGAGACCUCCCGGTT	464
HCVa:327 siRNA 3'-classI 4bp	AGACCUUGGUUACGAGACCUCCCGGTT	465
HCVa:327 siRNA 5'-classI 10bp	GGUCUACGAGACCUCCCGGUUCCGGGAGGUCU	466
HCVa:327 siRNA 5'-classI 8bp	GGUCUACGAGACCUCCCGGUUCCGGGAGGU	467
HCVa:327 siRNA 5'-classI 6bp	GGUCUACGAGACCUCCCGGUUCCGGGAG	468
HCVa:327 siRNA 5'-classI 4bp	GGUCUACGAGACCUCCCGGUUCCGGG	469
HCVa:327 siRNA 3'-gaaa 10bp	CUCGUAGACCGAAAGGUUACGAGACCUCCCGGTT	470
HCVa:327 siRNA 3'-gaaa 8bp	CGUAGACCGAAAGGUUACGAGACCUCCCGGTT	471
HCVa:327 siRNA 3'-gaaa 6bp	UAGACCGAAAGGUUACGAGACCUCCCGGTT	472
HCVa:327 siRNA 3'-gaaa 4bp	GACCGAAAGGUUACGAGACCUCCCGGTT	473
HCVa:327 siRNA 5'-gaaa 10bp	GGUCUACGAGACCUCCCGGUUGAAACCGGGAGGUC	474
HCVa:327 siRNA 5'-gaaa 8bp	GGUCUACGAGACCUCCCGGUUGAAACCGGGAGG	475
HCVa:327 siRNA 5'-gaaa 6bp	GGUCUACGAGACCUCCCGGUUGAAACCGGGGA	476
HCVa:327 siRNA 5'-gaaa 4bp	GGUCUACGAGACCUCCCGGUUGAAACCGG	477
HCVa:327 siRNA 3'-uuuguguuag 10bp	CGUAGACCUUUUUGUUGUAGGGUUCUACGAGACCUCCCGGTT	478
HCVa:327 siRNA 3'-uuuguguuag 8bp	UAGACCUUUUUGUUGUAGGGUUCUACGAGACCUCCCGGTT	479
HCVa:327 siRNA 3'-uuuguguuag 6bp	GACCUUUUUGUUGUAGGGUUCUACGAGACCUCCCGGTT	480
HCVa:327 siRNA 3'-uuuguguuag 4bp	CCUUUUUGUUGUAGGGUUCUACGAGACCUCCCGGTT	481
HCVa:327 siRNA 5'-uuuguguuag 10bp	GGUCUACGAGACCUCCCGGUUUUUGUAGCCGGGAGGUC	482
HCVa:327 siRNA 5'-uuuguguuag 8bp	GGUCUACGAGACCUCCCGGUUUUUGUAGCCGGGAGG	483
HCVa:327 siRNA 5'-uuuguguuag 6bp	GGUCUACGAGACCUCCCGGUUUUUGUAGCCGGGGA	484
HCVa:327 siRNA 5'-uuuguguuag 4bp	GGUCUACGAGACCUCCCGGUUUUUGUAGCCCGG	485
HCVa:327 siRNA 3'-classI 10bp stab08 (antisense)	ucucGuuAGAccuuGGucuAcGAGAccucccGGTsT	486
HCVa:327 siRNA 3'-classI 8bp stab08 (antisense)	ucGuuAGAccuuGGucuAcGAGAccucccGGTsT	487
HCVa:327 siRNA 3'-classI 6bp stab08 (antisense)	GuuAGAccuuGGucuAcGAGAccucccGGTsT	488
HCVa:327 siRNA 3'-classI 4bp stab08 (antisense)	AGAccuuGGucuAcGAGAccucccGGTsT	489
HCVa:327 siRNA 5'-classI 10bp stab08 (antisense)	GGucuAcGAGAccucccGGuuuccGGGAGGucu	490

MBHB 03-465-E; (400/160)

491	HCVa:327 siRNA 5'-class1 8bp stab08 (antisense)	<u>GGuCuAcGAGAccuuccGGuuuccGGGAGGu</u>
492	HCVa:327 siRNA 5'-class1 6bp stab08 (antisense)	<u>GGuCuAcGAGAccuuccGGuuuccGGGAG</u>
493	HCVa:327 siRNA 5'-class1 4bp stab08 (antisense)	<u>GGuCuAcGAGAccuuccGGuuuccGGG</u>
494	HCVa:327 siRNA 3'-gaaa 10bp stab08 (antisense)	<u>cUcGuAGAccGAAAGGucUAcGAGAccuuccGGTsT</u>
495	HCVa:327 siRNA 3'-gaaa 8bp stab08 (antisense)	<u>cGuAGAccGAAAGGucUAcGAGAccuuccGGTsT</u>
496	HCVa:327 siRNA 3'-gaaa 6bp stab08 (antisense)	<u>uAGAccGAAAGGucUAcGAGAccuuccGGTsT</u>
497	HCVa:327 siRNA 3'-gaaa 4bp stab08 (antisense)	<u>GAccGAAAGGucUAcGAGAccuuccGGTsT</u>
498	HCVa:327 siRNA 5'-gaaa 10bp stab08 (antisense)	<u>GGuCuAcGAGAccuuccGGuuGAAAaccGGAGGuc</u>
499	HCVa:327 siRNA 5'-gaaa 8bp stab08 (antisense)	<u>GGuCuAcGAGAccuuccGGuuGAAAaccGGAGG</u>
500	HCVa:327 siRNA 5'-gaaa 6bp stab08 (antisense)	<u>GGuCuAcGAGAccuuccGGuuGAAAaccGGGA</u>
501	HCVa:327 siRNA 5'-gaaa 4bp stab08 (antisense)	<u>GGuCuAcGAGAccuuccGGuuGAAAaccGG</u>
502	HCVa:327 siRNA 3'-uuuguguag 10bp stab08 (antisense)	<u>cGuAGAccuuuuuuGuUAGGGucUAcGAGAccuuccGGTsT</u>
503	HCVa:327 siRNA 3'-uuuguguag 8bp stab08 (antisense)	<u>uAGAccuuuuuuGuUAGGGucUAcGAGAccuuccGGTsT</u>
504	HCVa:327 siRNA 3'-uuuguguag 6bp stab08 (antisense)	<u>GAccuuuuuuGuUAGGGucUAcGAGAccuuccGGTsT</u>
505	HCVa:327 siRNA 3'-uuuguguag 4bp stab08 (antisense)	<u>ccuuuuuuGuUAGGGucUAcGAGAccuuccGGTsT</u>
506	HCVa:327 siRNA 5'-uuuguguag 10bp stab08 (antisense)	<u>GGuCuAcGAGAccuuccGGuuuuuuGuUAGccGGGAGGuc</u>
507	HCVa:327 siRNA 5'-uuuguguag 8bp stab08 (antisense)	<u>GGuCuAcGAGAccuuccGGuuuuuuGuUAGccGGGAGG</u>
508	HCVa:327 siRNA 5'-uuuguguag 6bp stab08 (antisense)	<u>GGuCuAcGAGAccuuccGGuuuuuuGuUAGccGGGA</u>
509	HCVa:327 siRNA 5'-uuuguguag 4bp stab08 (antisense)	<u>GGuCuAcGAGAccuuccGGuuuuuuGuUAGccGGG</u>
510	HCVa:347L23 siRNA (327C) stab08 (antisense)	<u>AcGGucUAcGAGAccuuccGGTsT</u>
511	HCVa:346L22 siRNA (327C) stab08 (antisense)	<u>cGGuCuAcGAGAccuuccGGTsT</u>
512	HCVa:344L20 siRNA (327C) stab08 (antisense)	<u>GucUAcGAGAccuuccGGTsT</u>
513	HCVa:343L19 siRNA (327C) stab08 (antisense)	<u>ucUAcGAGAccuuccGGTsT</u>
514	HCVa:342L18 siRNA (327C) stab08 (antisense)	<u>cUAcGAGAccuuccGGTsT</u>
515	HCVa:341L17 siRNA (327C) stab08 (antisense)	<u>uAcGAGAccuuccGGTsT</u>
516	HCVa:340L16 siRNA (327C) stab08 (antisense)	<u>AcGAGAccuuccGGTsT</u>
517	HCVa:339L15 siRNA (327C) stab08 (antisense)	<u>cGAGAccuuccGGTsT</u>
518	HCVa:345L21 siRNA (327C) stab08 GG (antisense)	<u>GGuCuAcGAGAccuuccGGGsG</u>
519	HCVa:345L20 siRNA (327C) stab08 G (antisense)	<u>GGuCuAcGAGAccuuccGGsG</u>



MBHB 03-465-E; (400/160)

	HCVa:345L20 siRNA (327C) stab08 (antisense)	GG <u>u</u> AcGAGAccuccGGsT	520
	HCVa:345L19 siRNA (327C) stab08 (antisense)	GG <u>u</u> AcGAGAccuccGsG	521
	HCVa:345L18 siRNA (327C) stab08 (antisense)	GG <u>u</u> AcGAGAccuccsG	522
	HCVa:345L17 siRNA (327C) stab08 (antisense)	GG <u>u</u> AcGAGAccuccsc	523
	HCVa:345L16 siRNA (327C) stab08 (antisense)	GG <u>u</u> AcGAGAccuisc	524
	HCVa:345L15 siRNA (327C) stab08 (antisense)	GG <u>u</u> AcGAGAccuisc	525
	HCVa:327U21 siRNA stab07 GT (sense)	B ccGGGAGG <u>u</u> cucGuAGAccGT B	526
	HCVa:327U21 siRNA stab07 (sense)	B cGGGAGG <u>u</u> cucGuAGAccTT B	527
	HCVa:328U20 siRNA stab07 (sense)	B GGGAGG <u>u</u> cucGuAGAccTT B	528
	HCVa:329U19 siRNA stab07 (sense)	B GGAGG <u>u</u> cucGuAGAccTT B	529
	HCVa:330U18 siRNA stab07 (sense)	B GAGG <u>u</u> cucGuAGAccTT B	530
	HCVa:331U17 siRNA stab07 (sense)	B AGG <u>u</u> cucGuAGAccTT B	531
	HCVa:332U16 siRNA stab07 (sense)	B ccGGGAGG <u>u</u> cucGuAGAccT B	532
	HCVa:327U21 siRNA stab07 (sense)	B ccGGGAGG <u>u</u> cucGuAGAcc B	533
	HCVa:327U21 siRNA stab07 (sense)	B ccGGGAGG <u>u</u> cucGuAGAc B	534
	HCVa:327U21 siRNA stab07 (sense)	B ccGGGAGG <u>u</u> cucGuAGA B	535
	HCVa:327U21 siRNA stab07 (sense)	B ccGGGAGG <u>u</u> cucGuAG B	536
31270	FLT1:349U21 siRNA stab09 (sense)	B CUGAGUJUAAAAAGGCACCCCTT B	537
31273	FLT1:367L21 siRNA (349C) stab10 (antisense)	GGGUGCCUUUUAAAACUCAGTst	538
31276	FLT1:349U21 siRNA stab09 inv (sense)	B CCCACGGAAAAUUUGAGUCTT B	539
31279	FLT1:367L21 siRNA (349C) stab10 inv (antisense)	GAGUCAUUUUUCCGUGGGTst	540
31679	HBV1598 all RNA (sense)	AGGUGAAGCGAAGUGCACAUU	541
31336	HBV1580U21 siRNA inv stab09 (sense)	B UCCACUJCGCUUCACGUGUTT B	542
31338	HBV1598L21 siRNA (1580C) inv stab10 (antisense)	ACACGUGAAGCGAAGUGGATst	543
32636	Luc3:80U21 siRNA stab07 (sense)	B AuAAGGcuAuGAAGAGAUATT B	544
32676	Luc3:98L21 siRNA (80C) stab08 (antisense)	uAucucuuAuAGccuuAuTst	545
32640	Luc3:237U21 siRNA stab07 (sense)	B cGuAuGcAGUGAAAACucjTT B	546
32680	Luc3:255L21 siRNA (237C) stab08 (antisense)	AGAGuuuuAcuGcAuAcGTst	547
32662	Luc3:1478U21 siRNA stab07 (sense)	B uGAcGGAAAAAGAGucGuTT B	548
32702	Luc3:1496L21 siRNA (1478C) stab08 (antisense)	AcGAucuuuuuccGucATst	549
32666	Luc3:1544U21 siRNA stab07 (sense)	B GAGuuGuuuuuGuGGAcGATT B	550
32706	Luc3:1562L21 siRNA (1544C) stab08 (antisense)	ucGuccAcAAAcAcAAAcTst	551
32672	Luc3:1607U21 siRNA stab07 (sense)	B GAGAGAuuccuAuAAAAAGcTT B	552

MBHB 03-465-E; (400/160)

32712	Luc3:1625L21 siRNA (1607C) stab08 (antisense)	GccuuuAuGAGGAucucucTsT	553
33139	HCVa:282U21 siRNA stab07 (sense)	B GcGAAAGGccuuGuGGuAcTT B	554
33179	HCVa:300L21 siRNA (282C) stab08 (antisense)	GuAccAAAGGccuuucGcTsT	555
33140	HCVa:283U21 siRNA stab07 (sense)	B cGAAAGGccuuGuGGuAcuTT B	556
33180	HCVa:301L21 siRNA (283C) stab08 (antisense)	AGuAccAAAGGccuuucGTsT	557
33145	HCVa:289U21 siRNA stab07 (sense)	B GccuuGuGGuAcuGccuGATT B	558
33185	HCVa:307L21 siRNA (289C) stab08 (antisense)	ucAGGcAGuAccAAAGGcTsT	559
33149	HCVa:304U21 siRNA stab07 (sense)	B cuGauAGGGGuGcuuGcGAGTT B	560
33183	HCVa:304L21 siRNA (286C) stab08 (antisense)	GGcAGuAccAAAGGccuuTsT	561
33150	HCVa:305U21 siRNA stab07 (sense)	B uGAuAGGGGuGcuuGcGAGuTT B	562
33190	HCVa:323L21 siRNA (305C) stab08 (antisense)	AcucGcAA GcAcccuAucA TsT	563
33151	HCVa:307U21 siRNA stab07 (sense)	B AuAGGGGuGcuuGcGAGuGcTT B	564
33191	HCVa:325L21 siRNA (307C) stab08 (antisense)	GcAcucGcAA GcAcccuAuTsT	565
33158	HCVa:317U21 siRNA stab07 (sense)	B uGcGAGuGccccGGGAGGGuTT B	566
33187	HCVa:317L21 siRNA (299C) stab08 (antisense)	AAAGcAcccuAucAGGcAGuTsT	567
33210	HBV:258U21 siRNA stab07 (sense)	B GuGGUGGAcuucucucAAuTT B	568
33250	HBV:276L21 siRNA (258C) stab08 (antisense)	AuuGAGAGAA GucAccAcTsT	569
33212	HBV:260U21 siRNA stab07 (sense)	B GGuGGAcuucucucAAuuuTT B	570
33252	HBV:278L21 siRNA (260C) stab08 (antisense)	AAuuuGAGAGAA GucAccTsT	571
33214	HBV:263U21 siRNA stab07 (sense)	B GGAcuucucucAAuuuucTT B	572
33254	HBV:281L21 siRNA (263C) stab08 (antisense)	AGAAAAuuGAGAGAA GuccTsT	573
32429	HBV:1583U21 siRNA stab07 (sense)	B GcAcuucGcuucAccucGTT B	574
32438	HBV:1601L21 siRNA (1583C) stab08 (antisense)	cAGAGGuGAA GcGAA GucGcTsT	575
33226	HBV:1585U21 siRNA stab07 (sense)	B AcuucGcuucAccucGcATT B	576
33266	HBV:1603L21 siRNA (1585C) stab08 (antisense)	uGcAGAGGuGAA GcGAA GuTsT	577
31651	HBV:1580U21 siRNA stab06 (sense)	B UGUGcAcUUCGCUUCACCCU TT B	578
31652	HBV:1580U21 siRNA inv stab06 (sense)	B UCCACUUCGCUUCACCGUGU TT B	579
31653	HBV:1580U21 siRNA stab16 (sense)	B UGUGcAcUUCGCUUCACCCU TT B	580
31654	HBV:1580U21 siRNA inv stab16 (sense)	B UCCACUUCGCUUCACCGUGU TT B	581
31657	HBV:1580U21 siRNA stab18 (sense)	B uGuGcAcuucGcuucAccuTT B	582
31658	HBV:1580U21 siRNA inv stab18 (sense)	B uccAcuucGcuucAcGuGuTT B	583
33573	HBV:1598L20 siRNA (1581C) stab08 (antisense)	AGGuGAA GcGAA GuGcAcTsT	584
33577	HBV:1581U20 siRNA stab07 modB (sense)	GuGcAcuucGcuucAccuTT	585
34124	HBV:264L15 (246C) 5p palindrome siRNA	pCACGAGUCUAGACUC GUGB	586
34428	5' n-3 C31270 FLT1:349U21 siRNA stab09 (sense)	GAGUUJAAAAAGGCACCCCTT B	587
34429	5' n-4 C31270 FLT1:349U21 siRNA stab09 (sense)	AGUUJAAAAAGGCACCCCTT B	588
34430	5' n-5 C31270 FLT1:349U21 siRNA stab09 (sense)	GUUUJAAAAAGGCACCCCTT B	589
34431	5' n-7 C31270 FLT1:349U21 siRNA stab09 (sense)	UUJAAAAAGGCACCCCTT B	590

MBHB 03-465-E; (400/160)

34432	5' n-9 C31270 FLT1:349U21 siRNA stab09 (sense)	AAAAGGCCCCCTT B	591
34435	3' n-3 C31270 FLT1:349U21 siRNA stab09 (sense)	B CUGAGUUUUAAAAGGCCACC	592
34436	3' n-4 C31270 FLT1:349U21 siRNA stab09 (sense)	B CUGAGUUUUAAAAGGCCACC	593
34437	3' n-5 C31270 FLT1:349U21 siRNA stab09 (sense)	B CUGAGUUUUAAAAGGCCACC	594
34438	3' n-7 C31270 FLT1:349U21 siRNA stab09 (sense)	B CUGAGUUUUAAAAGGCCACC	595
34439	5' n-1 C31273 FLT1:367L21 siRNA (349C) stab10 (antisense)	GGUGCCUUUUAAAACUCAGTsT	596
34440	5' n-2 C31273 FLT1:367L21 siRNA (349C) stab10 (antisense)	GUGCCUUUUAAAACUCAGTsT	597
34441	5' n-3 C31273 FLT1:367L21 siRNA (349C) stab10 (antisense)	UGCCUUUUAAAACUCAGTsT	598
34442	5' n-4 C31273 FLT1:367L21 siRNA (349C) stab10 (antisense)	GCCUUUUAAAACUCAGTsT	599
34443	5' n-5 C31273 FLT1:367L21 siRNA (349C) stab10 (antisense)	CCUUUUAAAACUCAGTsT	600
34444	3' n-1 C31273 FLT1:367L21 siRNA (349C) stab10 (antisense)	GGGUGCCUUUUAAAACUCAGT	601
34445	3' n-2 C31273 FLT1:367L21 siRNA (349C) stab10 (antisense)	GGGUGCCUUUUAAAACUCAG	602
34446	3' n-3 C31273 FLT1:367L21 siRNA (349C) stab10 (antisense)	GGGUGCCUUUUAAAACUCA	603
34447	3' n-4 C31273 FLT1:367L21 siRNA (349C) stab10 (antisense)	GGGUGCCUUUUAAAACUC	604
34448	3' n-5 C31273 FLT1:367L21 siRNA (349C) stab10 (antisense)	GGGUGCCUUUUAAAACU	605
34449	3' n-7 C31273 FLT1:367L21 siRNA (349C) stab10 (antisense)	GGGUGCCUUUUAAA	606
34450	3' n-9 C31273 FLT1:367L21 siRNA (349C) stab10 (antisense)	GGGUGCCUUUUUA	607
34501	EGFPc1:1106L21 siRNA (1088C) stab08 Blunt (antisense)	uucAccuuGAuGccGuucU	608
34503	KDR:3733L21 siRNA (3715C) stab08 Blunt (antisense)	GccAGcAGuccAGcAuGGU	609
34505	KDR:3733L21 siRNA (3715C) inv stab08 Blunt (antisense)	uGGuAcGAccuGAcGAccG	610
34727	HBV:263U21 siRNA stab00 5'(n-1) (sense)	GACUUCUCACAAUUUUUCUTT	611
34728	HBV:281L21 siRNA stab00 (263C) 3'(n-1) (antisense)	AGAAAAUUGAGAGAAAGUCTT	612
34729	HBV:263U21 siRNA stab00 5'(n-2) (sense)	ACUUCUCUCAUUUUUCUTT	613
34730	HBV:281L21 siRNA stab00 (263C) 3'(n-2) (antisense)	AGAAAAUUGAGAGAAAGUCTT	614
34731	HBV:263U21 siRNA stab00 5'(n-3) (sense)	CUUCUCUCAUUUUUCUTT	615
34732	HBV:281L21 siRNA stab00 (263C) 3'(n-3) (antisense)	AGAAAAUUGAGAGAAAGTT	616
34733	HBV:263U21 siRNA stab00 5'(n-4) (sense)	UUUCUCACAAUUUUUCUTT	617
34734	HBV:281L21 siRNA stab00 (263C) 3'(n-4) (antisense)	AGAAAAUUGAGAGAAATT	618
34735	HBV:263U21 siRNA stab00 5'(n-5) (sense)	UCUCUCAUUUUUCUTT	619
34736	HBV:281L21 siRNA stab00 (263C) 3'(n-5) (antisense)	AGAAAAUUGAGAGATT	620

MBHB 03-465-E; (400/160)

35081	HBV:1601L20 siRNA (1583C) stab24 (antisense)	AGAGGUGAAGcGAAGuGcTsT	621
35082	HBV:1601L20 siRNA (1583C) stab08 N7 (antisense)	AGAGGUGAAGcGAAGuGcTsT	622
35279	Luc3:80U19 siRNA (sense)	AUAAGGCUAUGAAAGAGAU	623
35280	Luc3:1544U19 siRNA (sense)	GAGUUGUGUUIUGUGGACGA	624
35281	Luc3:1288U19 siRNA (sense)	GAACACUUCUUAUCUGUUG	625
35282	Luc3:268U19 siRNA (sense)	AUGCCGGUGUUGGGCGCGU	626
35283	rLuc:231U19 siRNA (sense)	CCUUAUUGGUUUGGGCAA	627
35284	rLuc:165U19 siRNA (sense)	CUCUUCUUAUUUAUGGGGA	628
35285	rLuc:84U19 siRNA (sense)	UGUUCUUGAUUCAUUUUUU	629
35286	rLuc:375U19 siRNA (sense)	GGCAUUCUUAUUAAGCUAU	630
35287	Luc3:98L19 siRNA (80C) (antisense)	UAUCUCUUCAUAGCCUUU	631
35288	Luc3:1562L19 siRNA (1544C) (antisense)	UCGUCCACAAAACACAACUC	632
35289	Luc3:1306L19 siRNA (1288C) (antisense)	CAACGAUGAAGAAAGUGUUC	633
35290	Luc3:286L19 siRNA (268C) (antisense)	ACGCGCCCAACACACCGGAU	634
35291	rLuc:249L19 siRNA (231C) (antisense)	UUUGCCCAUACCAAUUAGG	635
35292	rLuc:183L19 siRNA (165C) (antisense)	UCGCCAUAAAUAAGAAGAG	636
35293	rLuc:102L19 siRNA (84C) (antisense)	AUAAAUGAAUUAAGAAGAACA	637
35294	rLuc:393L19 siRNA (375C) (antisense)	AUAGCUUAUUAUGAAUUGCC	638
35764	Luc3:118U19 stab00 siRNA (sense)	AUUGCUUUUACAGAUGCAC	639
35765	Luc3:150U19 stab00 siRNA (sense)	CAUCACUUAACGCUAGUAC	640
35766	Luc3:255U19 stab00 siRNA (sense)	UCUCAAUUUUUAUUGCCCG	641
35767	Luc3:325U19 stab00 siRNA (sense)	UAUUAUGAACGGUGAAUUGC	642
35768	Luc3:326U19 stab00 siRNA (sense)	AUAUAGAACGGUGAAUUGCU	643
35769	Luc3:470U19 stab00 siRNA (sense)	AUIUACCAGGGAUUUCAGUC	644
35770	Luc3:503U19 stab00 siRNA (sense)	UCACAUCUCAUCUACCUC	645
35771	Luc3:595U19 stab00 siRNA (sense)	UCUGGAUCUACUGGUCUGC	646
35772	Luc3:676U19 stab00 siRNA (sense)	AUUUUUGCAAUCAAAUA	647
35773	Luc3:761U19 stab00 siRNA (sense)	GAUUAUUGAUUGUGGAU	648
35774	Luc3:764U19 stab00 siRNA (sense)	AUUUGAUUGUGGGAUUUCG	649
35775	Luc3:765U19 stab00 siRNA (sense)	UUUGAUUGUGGGAUUUCGA	650
35776	Luc3:769U19 stab00 siRNA (sense)	AUAUGUGGAUUCGAGUUG	651
35777	Luc3:806U19 stab00 siRNA (sense)	AAGAAGAGCUGUUUCUGAG	652
35778	Luc3:874U19 stab00 siRNA (sense)	UUCUCUUCUUCGCCAAA	653
35779	Luc3:875U19 stab00 siRNA (sense)	UCUCCUUCUUCGCCAAAAG	654
35780	Luc3:876U19 stab00 siRNA (sense)	CUCUUCUUCGCCAAAAGC	655
35781	Luc3:902U19 stab00 siRNA (sense)	UUGACAAAUACGAUUUAUC	656
35782	Luc3:938U19 stab00 siRNA (sense)	CUUCUGGUGGGCUCUCCCCU	657
35783	Luc3:1099U19 stab00 siRNA (sense)	CCAUIUUUUUGAAAGCGAAGG	658

MBHB 03-465-E; (400/160)

35784	Luc3:1100U19 stab00 siRNA (sense)	CAUUUUUUUGAAGCGAAGGU	659
35785	Luc3:1293U19 stab00 siRNA (sense)	CUUCUUCAUUCGUUGACCCGC	660
35786	Luc3:1340U19 stab00 siRNA (sense)	AUCAGGUGGCUCGCCGUGA	661
35787	Luc3:1512U19 stab00 siRNA (sense)	UCAAGUAACAACCCGGGAAA	662
35788	Luc3:1513U19 stab00 siRNA (sense)	CAAGUAACAACCCGGGAAA	663
35789	Luc3:136L19 (118C) stab00 siRNA (antisense)	GUGCAUCUGUAAAAGCAAU	664
35790	Luc3:168L19 (150C) stab00 siRNA (antisense)	GUACUCAGCGUAAAGUGAUG	665
35791	Luc3:273L19 (255C) stab00 siRNA (antisense)	CGGCAUAAAAGAAUUGAAGA	666
35792	Luc3:343L19 (325C) stab00 siRNA (antisense)	GCAAUUCACGJUUCAUUUA	667
35793	Luc3:344L19 (326C) stab00 siRNA (antisense)	AGCAAUUCACGJUUCAUUUA	668
35794	Luc3:488L19 (470C) stab00 siRNA (antisense)	GACUGAAAUCGCCUGGUAU	669
35795	Luc3:521L19 (503C) stab00 siRNA (antisense)	GGAGGUJAGAUAGAGUGUGA	670
35796	Luc3:613L19 (595C) stab00 siRNA (antisense)	GCAGACCAGUAGAUCCAGA	671
35797	Luc3:694L19 (676C) stab00 siRNA (antisense)	UGAUUUGAUUGCCAAAAUU	672
35798	Luc3:779L19 (761C) stab00 siRNA (antisense)	AAUCCACAUUCAAAAUJUC	673
35799	Luc3:782L19 (764C) stab00 siRNA (antisense)	CGAAAUCACACAUUCAAAAU	674
35800	Luc3:783L19 (765C) stab00 siRNA (antisense)	UCGAAAUCACACAUUCAAAA	675
35801	Luc3:787L19 (769C) stab00 siRNA (antisense)	CGACUCGAAAUCACACAUU	676
35802	Luc3:824L19 (806C) stab00 siRNA (antisense)	CUCAGAAACAGCUCUCUU	677
35803	Luc3:892L19 (874C) stab00 siRNA (antisense)	UUUUGGCGAAGAGGAGAA	678
35804	Luc3:893L19 (875C) stab00 siRNA (antisense)	CUUUUGGCGAAGAGGAGAA	679
35805	Luc3:894L19 (876C) stab00 siRNA (antisense)	GCUUUUGGCGAAGAGGAG	680
35806	Luc3:920L19 (902C) stab00 siRNA (antisense)	GAUAAAUCGUUUUUGUCA	681
35807	Luc3:956L19 (938C) stab00 siRNA (antisense)	AGGGGAGCGCCACCAGAA	682
35808	Luc3:1117L19 (1099C) stab00 siRNA (antisense)	CCUUCGUUCAAAAAAUUGG	683
35809	Luc3:1118L19 (1100C) stab00 siRNA (antisense)	ACCUUCGCUUCAAAAAAUUG	684
35810	Luc3:1311L19 (1293C) stab00 siRNA (antisense)	GCGGUCACGUAUGAAGAAG	685
35811	Luc3:1358L19 (1340C) stab00 siRNA (antisense)	UCAGCGGGAGCCACCUGAU	686
35812	Luc3:1530L19 (1512C) stab00 siRNA (antisense)	UUUCGCGGUUGUUAUCUUGA	687
35813	Luc3:1531L19 (1513C) stab00 siRNA (antisense)	UUUUCGCGGUUGUUAUCUUG	688
35819	HBV:263U19 siRNA stab07 minus TT & IB (sense)	GGAcuucucAAuuuuu	689
35821	HBV:281L19 siRNA (263C) stab24 minus TsT (antisense)	AGAAAAUUUGAGAGAAAGucc	690
35911	HBV:281L19 siRNA (263C) stab00 (antisense)	AGAAAAUUUGAGAGAAAGUCC	691
35912	PRKCA:116L19 siRNA (1143C) stab00 (antisense)	AUCCUGAAUACCCACAUCUCC	692
36457	FLT1:349U19 siRNA stab00 -3' TT (sense)	CUGAGUUUAAAAGGCCACCC	693
36459	FLT1:367L19 siRNA (349C) stab00 +5' IB -3' TT (antisense)	B GGGUGCCUUUUAAAACUCAG	694
36461	FLT1:349U21 siRNA stab07 -5' IB -3' TTB (sense)	cuGAGuuuuAAAAGGcAcAcc	695

MBHB 03-465-E; (400/160)

36462	FLT1:367L19 siRNA (349C) stab08 -3' TsT (antisense)	GGGUGccuuuuAAA-cucAG	696
32714	HCVa:313L21 siRNA (295C) v1 5'p palindrome	pACCCUUAUCAGGCAGUAACCA GUACUGCCUGAU B	697
32715	HCVa:313L21 siRNA (295C) v2 5'p palindrome	pACCCUUAUCAGGCAGUAACC GGUACUGCCUGAU B	698
32716	HCVa:5'p-345L21 (327C) v5 5'p palindrome siRNA	pGGUCUJACGAGACCUCGCCG AGGUCUCGUAGA B	699
32717	HCVa:5'p-345L21 (327C) v6 5'p palindrome siRNA	pGGUCUJACGAGACCUCUCC GGAGGUCUCGUA B	700
32718	FLT1:367L21 siRNA (349C) v1 5'p palindrome	pGGUGCCUUUUAAAACUC GAGUUUAAAAG B	701
32719	FLT1:367L21 siRNA (349C) v2 5'p palindrome	pGGUGCCUUUUAAAACUCAG GAGUUUAAAAG B	702
32720	FLT1:2967L21 siRNA (2949C) v1 5'p palindrome	pCAUCAGAGGCCUCCUJUGC AAGGAGGGCCUUCU B	703
32721	FLT1:2967L21 siRNA (2949C) v2 5'p palindrome	pCAUCAGAGGCCUCCUJUU AAGGAGGGCCUUCUG B	704
32722	FLT1:2967L21 siRNA (2949C) v3 5'p palindrome	pCAUCAGAGGCCUCCU AAGGAGGGCCUUCUG B	705
32723	mFAS:942L21 siRNA (924C; JL873) v1 5'p palindrome	pGUUCUGCGACAUUCGGCUU GCCGAUUGUCGCCA B	706
32724	mFAS:942L21 siRNA (924C; JL873) v2 5'p palindrome	pGUUCUGCGACAUUCGGC GCCGAUUGUCGCCA B	707
32725	HBV: 1598L21 (1580C) V palindrome siRNA	AGGUGAAGCGAAGUGCACA CUUCGCUUCA uB	708
32726	HBV:5'p-1598L21(1580C) v1 5'p palindrome siRNA	pAGGUGAAGCGGAAGUG CACUUCGCUU B	709
32727	HBV:5'p-1598L21(1580C) v2 5'p palindrome siRNA	pAGGUGAAGCGGAAGUG CACUUCGCUUC B	710
32728	HBV:5'p-1598L21(1580C) v3 5'p palindrome siRNA	pAGGUGAAGCGGAAGUG CACUUCGCUUCAC B	711
32729	HBV:5'p-1598L21(1580C) v4 5'p palindrome siRNA	pAGGUGAAGCGGAAGU ACUUCGCUUCAC B	712
32805	FLT1:373L21 siRNA (354C) v1 5'p palindrome	pGUGCUGGGUGCCUUUUAAA AGGCACCCAGC B	713
32806	FLT1:373L21 siRNA (354C) v2 5'p palindrome	pGUGCUGGGUGCCUUUUAAA GGCACCCAGC B	714
32807	FLT1:373L21 siRNA (354C) v3 5'p palindrome	pGUGCUGGGUGCCUUAAAGGCACCCAGC B	715
32808	FLT1:1247L21 siRNA (1229C) v1 5'p palindrome	pAAUGCUUUUAUCAUUAUU GAUAAAAGC B	716
32809	FLT1:1247L21 siRNA (1229C) v2 5'p palindrome	pAAUGCUUUUAUCAUUAUU GAUAAAAGC B	717
32810	FLT1:1247L21 siRNA (1229C) v3 5'p palindrome	pAAUGCUUUUAUCAUUAU GAUAAAAGC B	718
32811	FLT1:1247L21 siRNA (1229C) v4 5'p palindrome	pAAUGCUUUUAUCAUUAU GAUAAAAGC B	719
32812	FLT1:1247L21 siRNA (1229C) v5 5'p palindrome	pAAUGCUUUUAUCAUUAUU GAUAAAAGCAUU B	720
32813	FLT1:1247L21 siRNA (1229C) v6 5'p palindrome	pAAUGCUUUUAUCAUUAU GAUAAAAGCAUU B	721
33056	FLT1:367L21 siRNA (349C) v3 5'p palindrome	pGGUGCCUUUUAAAACUCAG GAGUUUAAAAGG B	722
33057	FLT1:367L21 siRNA (349C) v4 5'p palindrome	pGGUGCCUUUUAAAACUC GAGUUUAAAAGGCA B	723
33058	FLT1:367L21 siRNA (349C) v5 5'p palindrome	pGGUGCCUUUUAAAACU AGUUUAAAAGG B	724
33059	FLT1:367L21 siRNA (349C) v6 5'p palindrome	pGGUGCCUUUUAAAACU AGUUUAAAAGG B	725
33060	FLT1:367L21 siRNA (349C) v7 5'p palindrome	pGGUGCCUUUUAAAACU AGUUUAAAAGGCA B	726
33061	FLT1:367L21 siRNA (349C) v8 5'p palindrome	pGGUGCCUUUUAAAACU AGUUUAAAAGGCA B	727
33062	FLT1:367L21 siRNA (349C) v9 5'p palindrome	pGGUGCCUUUUAAAAC GUUUUAAAAGG B	728
33063	FLT1:367L21 siRNA (349C) v10 5'p palindrome	pGGUGCCUUUUAAAAC GUUUUAAAAGGCA B	729
33064	FLT1:367L21 siRNA (349C) v11 5'p palindrome	pGGUGCCUUUUAAAAC GUUUUAAAAGGCA B	730
34092	FLT1:373L18 siRNA (354C) v4 5'p palindrome	pUGCUGGGUGCCUUUUAAA AGGCACCCAGC B	731
34093	FLT1:373L17 siRNA (354C) v5 5'p palindrome	pGCUGGGUGCCUUUUAAA AGGCACCCAGC B	732
34094	FLT1:373L17 siRNA (354C) v6 5'p palindrome	pGCUGGGUGCCUUUUAAA AGGCACCCAGCT B	733

MBHB 03-465-E; (400/160)

34095	FLT1:373L17 siRNA (354C) v7 5p palindrome	pCUGGGGUGCCUUUUAAA AGGCACCCAG B	734
34096	FLT1:373L16 siRNA (354C) v8 5p palindrome	pCUGGGGUGCCUUUUAAA AGGCACCCAG B	735
34097	FLT1:373L16 siRNA (354C) v9 5p palindrome	pCUGGGGUGCCUUUUAAA AGGCACCCCA B	736
34098	FLT1:373L15 siRNA (354C) v10 5p palindrome	pUGGGGUGCCUUUUAAA AGGCACCCCA B	737
34099	FLT1:373L15 siRNA (354C) v11 5p palindrome	pUGGGGUGCCUUUUAAA AGGCACCCAT B	738
34100	FLT1:373L15 siRNA (354C) v12 5p palindrome	pUGGGGUGCCUUUUAAA AGGCACCCAT B	739
34101	FLT1:1247L21 siRNA (1229C) v14 5p palindrome	pJGCUUUAUCAUAUAUAU GAUAAAAGCA B	740
34102	FLT1:1247L21 siRNA (1229C) v15 5p palindrome	pJGCUUUAUCAUAUAUAU GAUAAAAGC B	741
34103	FLT1:1247L21 siRNA (1229C) v16 5p palindrome	pGCUUUAUCAUAUAUAU GAUAAAAGC B	742
34104	FLT1:1247L17 siRNA (1229C) v5 palindrome	AAUGCUUUAUCAUAUAU GAUAAAAGCAU B	743
34105	FLT1:1247L17 siRNA (1229C) v7 5p palindrome	pAAUGCUUUAUCAUAUAU GAUAAAAGCAU B	744
34106	FLT1:1247L17 siRNA (1229C) v8 5p palindrome	pAAUGCUUUAUCAUAUAU GAUAAAAGCAU B	745
34107	FLT1:1247L17 siRNA (1229C) v9 5p palindrome	pAAUGCUUUAUCAUAUAU GAUAAAAGCAU B	746
34108	FLT1:1247L16 siRNA (1229C) v10 5p palindrome	pAUGCUUUAUCAUAUAU GAUAAAAGCAU B	747
34109	FLT1:1247L16 siRNA (1229C) v11 5p palindrome	pAUGCUUUAUCAUAUAU GAUAAAAGCAU B	748
34110	FLT1:1247L16 siRNA (1229C) v12 5p palindrome	pAUGCUUUAUCAUAUAU GAUAAAAGCAU B	749
34111	FLT1:1247L16 siRNA (1229C) v13 5p palindrome	pAUGCUUUAUCAUAUAU GAUAAAAGCA B	750
34112	FLT1:1247L17 siRNA (1229C) v14 5p palindrome	pAAUGCUUUAUCAUAUAU GAUAAAAGCAU B	751
34113	FLT1:1247L17 siRNA (1229C) v15 5p palindrome	pAAUGCUUUAUCAUAUAU GAUAAAAGCAU B	752
34114	FLT1:1247L17 siRNA (1229C) v16 5p palindrome	pAAUCCUUUAUCUUAUAU GAUAAAAGCAU B	753
34115	FLT1:1247L17 siRNA (1229C) v17 5p palindrome	pAAUGCUUUAUCAUAUAU GAUAAAAGCAU B	754
34116	FLT1:1247L17 siRNA (1229C) v18 5p palindrome	pAAUGCUUUAUCAUAUAU GAUAAAAGCAU B	755
34117	HBV:197L18 (179C) 5p palindrome siRNA	pCGAGCAGGGGUGCCUAGGA CCCCUGCUCGB	756
34118	HBV:197L17 (179C) 5p palindrome siRNA	pGAGCAGGGGUGCCUAGGA CCCCUGCUCB	757
34119	HBV:197L16 (179C) 5p palindrome siRNA	pAGCAGGGGUGCCUAGGA CCCCUGCUB	758
34120	HBV:197L15 (179C) 5p palindrome siRNA	pGCAGGGGUGCCUAGGA CCCCUGCB	759
34121	HBV:264L19 (246C) 5p palindrome siRNA	pCCACCACGAGUCUAGACUC GUGGUGB	760
34122	HBV:264L17 (246C) 5p palindrome siRNA	pACCACGAGUCUAGACUC GUGGUB	761
34123	HBV:264L16 (246C) 5p palindrome siRNA	pCCACGAGUCUAGACUC GUGGB	762
34125	HBV:1597L17 (1581C) 5p palindrome siRNA	pGGUGAAGCGAAGUGGCAC UUCGCUACCCB	763
34126	HBV:1597L16 (1581C) 5p palindrome siRNA	pGUGAAGCGAAGUGGCAC UUCGCUUCACB	764
34127	HBV:1597L15 (1581C) 5p palindrome siRNA	pUGAAGCGAAGUGGCAC UUCGCUUCAB	765
34128	HCVb:100L18 (82C) 5p palindrome siRNA	pUCAACUAACGCCCAUGGC GUJAGUAUGAB	766
34129	HCVb:100L17 (82C) 5p palindrome siRNA	pCAUACUAACGCCCAUGGC GUJAGUAUGB	767
34130	HCVb:100L16 (82C) 5p palindrome siRNA	pAUACUAACGCCCAUGGC GUJAGUAUB	768
34131	HCVb:100L15 (82C) 5p palindrome siRNA	pUACUAACGCCCAUGGC GUJAGUAB	769
34132	HCVb:144L19 (126C) 5p palindrome siRNA	pACUAGGCCUCUCCCGGGAG AGCCAUAGUB	770
34133	HCVb:144L18 (126C) 5p palindrome siRNA	pCUAUGGCCUCUCCCGGGAG AGCCAUAGB	771

MBHB 03-465-E; (400/160)

34134	HCYb:144L17 (126C) 5p palindrome siRNA	pUAUGGCUCUCCCGGGAG AGCCAUAUB	772
34135	HCYb:144L16 (126C) 5p palindrome siRNA	pAUGGCUCUCCCGGGAG AGCCAUAUB	773
34136	HCYb:144L15 (126C) 5p palindrome siRNA	pUGGCUCUCCCGGGAG AGCCAB	774
34137	HCYb:172L17 (155C) 5p palindrome siRNA	pCCGGUGUACUCACCCGGU GAGUACACCCGGB	775
34138	HCYb:172L16 (155C) 5p palindrome siRNA	pCGGUGUACUCACCCGGU GAGUACACCCGGB	776
34139	HCYb:172L15 (155C) 5p palindrome siRNA	pGGUGUACUCACCCGGU GAGUACACCCB	777
34140	HCYb:332L17 (315C) 5p palindrome siRNA	pCUACGAGACCUCCCGGG AGGUCUCGUAGB	778
34141	HCYb:332L16 (315C) 5p palindrome siRNA	pUACGAGACCUCCCGGG AGGUCUCGUAB	779
34142	HCYb:332L15 (315C) 5p palindrome siRNA	pACGAGACCUCCCGGG AGGUCUCGUB	780
34676	FLT1:1501U21 siRNA stab00 (sense)	CUCACUGCCACUCUAAUUGTT	781
34677	FLT1:1502U21 siRNA stab00 (sense)	UCACUGCCACUCUAAUUGTT	782
34678	FLT1:1503U21 siRNA stab00 (sense)	CACUGCCACUCUAAUUGUCTT	783
34679	FLT1:5353U21 siRNA stab00 (sense)	GACCCGUCUCUAAUACCAATT	784
34680	KDR:503U21 siRNA stab00 (sense)	AGAGUGGGAGUGAGCAAAAGTT	785
34681	VEGF:360U21 siRNA stab00 (sense)	AGAGACGGGGUCAGAGAGATT	786
34682	VEGF:1562U21 siRNA stab00 (sense)	AGCAUUUGUUUUAACAAGATT	787
34683	HBV:1583U21 siRNA stab00 (sense)	GCACUUCGCUACCCUCUGTT	788
34684	FLT1:1519L21 (1501C) siRNA stab00	CAAUUAGAGUGGCAGUGAGATT	789
34685	FLT1:1520L21 (1502C) siRNA stab00	ACAAUUAGAGUGGCAGUGATT	790
34686	FLT1:1521L21 (1503C) siRNA stab00	GACAAUJAGAGUGGCAGUGTT	791
34687	FLT1:5371L21 (5353C) siRNA stab00	UUGGUUAJAGAGACGGGUGCTT	792
34688	KDR:521L21 (503C) siRNA stab00	CUUUGCUCACUGCCACUCUTT	793
34689	VEGF:378L21 (360C) siRNA stab00	UCUCUCUGACCCCGUCUCUTT	794
34690	VEGF:1580L21 (1562C) siRNA stab00	UCUUGUACAAACAAAUGCUTT	795
34691	HBV:1601L21 siRNA (1583C) stab00	CAGAGGUGAAGCGAAGUGCTT	796
34692	F/K bf-1a siRNA stab00 [FLT1:1519L21 (1501C) -14 +KDR:503U21]	CAAUUAGAGUGGCAGUGAGCAAAAGTT	797
34693	F/K bf-2a siRNA stab00 [FLT1:1520L21 (1502C) -13 +KDR:503U21]	ACAAUUAGAGUGGCAGUGAGCAAAAGTT	798
34694	F/K bf-3a siRNA stab00 [FLT1:1521L21 (1503C) -12 +KDR:503U21]	GACAAUUAGAGUGGCAGUGAGCAAAAGTT	799
34695	V/F bf-1a siRNA stab00 [FLT1:3664L19 (3646C) -5 +VEGF:1562U21]	UGUGCCAGCAGUCCAGCAUUUUGUACAAGATT	800
34696	V/F bf-2a siRNA stab00 [FLT1:5371L19 (5353C) -12 +VEGF:360U21]	UUGGUUAJAGAGACGGGGUCAGAGATT	801
34697	F/K bf-1b siRNA stab00 [KDR:521L21 (503C) -14 +FLT1:1501U21]	CUUUGCUCACUGCCACUCUAAUUGTT	802
34698	F/K bf-2b siRNA stab00 [KDR:521L21 (503C) -13 +FLT1:1502U21]	CUUUGCUCACUGCCACUCUAAUUGTT	803
34699	F/K bf-3b siRNA stab00 [KDR:521L21 (503C) -12	CUUUGCUCACUGCCACUCUAAUUGUCTT	804



MJDHID UJ-40J-D, (TUVU, IUVJ)

	+FLT1:1503U21]			
34700	V/F bf-1b siRNA stab00 [VEGF:1580L19 (1562C) -5 +FLT1:3646U21]	UCUUGUACAAAGAAUUGCUGGACUGCGGCACATT		805
34701	V/F bf-2b siRNA stab00 [VEGF:378L21 (360C) -12 +FLT1:5353U21]	UCUCUCUGACCCCGUCUCUUAUACCAATT		806
34702	V/F bf-3a siRNA stab00 [FLT1:3664L19 (3646C) + VEGF1420:U21]	UGUGCCAGCAGUCCAGCAU UGUGAAUUGCAGACCAAAAGATT		807
34703	V/F bf-3b siRNA stab00 [VEGF1438:L19 (1420C) + FLT1:3646U21]	UCUUUGGUCUGCAUUUACA AUGCUGGGACUGCGGCACATT		808
34704	V/F bf-4a siRNA stab00 [FLT1:3664L17 (3648C) + VEGF1422:U19]	UGUGCCAGCAGUCCAGC UGAAUUGCAGACCAAAAGATT		809
34705	V/F bf-4b siRNA stab00 [VEGF1438:L17 (1422C) + FLT1:3648U19]	UCUUUGGUCUGCAUUUCA GCUGGACUGCGGCACATT		810
34706	V/F bf-5a siRNA stab00 [FLT1:3664L19 (3646C) + VEGF1423:U19]	UGUGCCAGCAGUCCAGCAU GAAUUGCAGACCAAAAGATT		811
34707	V/F bf-5b siRNA stab00 [VEGF1441:L19 (1420C) + FLT1:3646U21]	CUUUUUUGGUCUGCAUUC AUGCUGGACUGCGGCACATT		812
34708	V/F bf-6a siRNA stab00 [FLT1:3664L19 (3646C) + VEGF1421:U21]	UGUGCCAGCAGUCCAGCAU GUGAAUUGCAGACCAAAAGATT		813
34709	V/F bf-6b siRNA stab00 [VEGF1439:L19 (1421C) + FLT1:3646U21]	UUCUUUGGUCUGCAUUCAC AUGCUGGACUGCGGCACATT		814
34710	H/P bf-1a siRNA stab00 [HBV:1601L19 (1583C) + PRKCA:1143U21]	CAGAGGUAGAAGCGAAGUGC GGAUGUGGUGAUUCAGGAUTT		815
34711	H/P bf-1b siRNA stab00 [PRKCA:1161L19 (1143C) + HBV:1583U21]	AUCCUGAAUACCCACCAUCC GCACUUCGCUUCCACCCUCUGTT		816
34712	H/P bf-2a siRNA stab00 [HBV:281L19 (263C) + PRKCA:1143U21]	AGAAAAUUGAGAGAAAGUCC GGAUGUGGUGAUUCAGGAUTT		817
34713	H/P bf-2b siRNA stab00 [PRKCA:1161L19 (1143C) + HBV:263U21]	AUCCUGAAUACCCACCAUCC GGACUUCUCUCAUUUUUCUTT		818
34955	HBV:281L19 (263C) v1 palindrome siRNA	AGAAAAUUGAGAGAAAGUUCUCUCAUUUUUCU		819
34956	HBV:281L19 (263C) v2 palindrome siRNA	AGAAAAUUGAGAGAAAGCUCUCUCAUUUUUCU		820
34957	HBV:281L19 (263C) v3 palindrome siRNA	AGAAAAUUGAGAGAAUUCUCUCAUUUUUCU		821
34958	HBV:281L19 (263C) v4 palindrome siRNA	AGAAAAUUGAGAGAAUUCUCUCAUUUUUCU		822
34959	HBV:281L19 (263C) v5 palindrome siRNA	AGAAAAUUGAGAGAAAGUUCUCUCAUUUUUCU		823
34960	HBV:281L19 (263C) v6 palindrome siRNA	AGAAAAUUGAGAGAAAGCUCUCUCAUUUUUCU		824
34961	HBV:281L19 (263C) v7 palindrome siRNA	AGAAAAUUGAGAGAAUUCUCUCAUUUUUCU		825
34962	HBV:281L19 (263C) v8 palindrome siRNA	AGAAAAUUGAGAGAAUUCUCUCAUUUUUCU		826
34963	HBV:1598L17 (1581C) v1 palindrome siRNA	AGAAAAUUGAGAGAAUUCUCUCAUUUUUCU		827
34964	HBV:1598L17 (1581C) v2 palindrome siRNA	GGUAGGCGAAGUAGCAUUCGCUUCACCC		828
34965	HBV:1598L17 (1581C) v3 palindrome siRNA	GGUAGGCGAAGUAGCAUUCGCUUCACCT		829
34966	HBV:1598L17 (1581C) v4 palindrome siRNA	GGUAGGCGAAGUAGCAUUCGCUUCACCT		830
34967	HBV:1598L17 (1581C) v5 palindrome siRNA	GGUAGGCGAAGUAGCAUUCGCUUCACUT		831

MIBHB 03-465-E; (400/160)

34968	HBV:1598L17 (1581C) v6 palindrome siRNA	GGUGAAGCGAAGUGCACUUCGCUUCAUU	832
34969	HBV:1598L19 (1581C) v1 palindrome siRNA	GAGGUGAAGCGAAGUGCACUUCGCUUCAACCUC	833
34970	HBV:1598L19 (1581C) v2 palindrome siRNA	AGGUGAAGCGAAGUGCACUUCGCUUCAACCUC	834
34971	HBV:265L19 (246C) v1 palindrome siRNA	CCACCACGAGUCUAGACUCUGGUGG	835
34972	HBV:265L19 (246C) v2 palindrome siRNA	CCACCACGAGUCUAGACUCUGGUGG	836
34973	HBV:265L18 (246C) v1 palindrome siRNA	CACCACGAGUCUAGACUCUGGUGG	837
34974	HBV:265L18 (246C) v2 palindrome siRNA	CACCACGAGUCUAGACUCUGGUGGTT	838
34975	HBV:265L18 (246C) v3 palindrome siRNA	CACCACGAGUCUAGACUCUGGUGG	839
34976	HBV:265L18 (246C) v4 palindrome siRNA	CACCACGAGUCUAGACUCUGGUGGTT	840
34977	HBV:265L17 (246C) v1 palindrome siRNA	ACCACGAGUCUAGACUCUGGUGG	841
34978	HBV:265L17 (246C) v2 palindrome siRNA	ACCACGAGUCUAGACUCUGGUGGTT	842
35027	TGFBR1:408L19 (390C) palindrome siRNA	AGUUCUUIUUIUUGCAAUAAAUAAGAACU	843
35028	TGFBR1:406L17 (390C) palindrome siRNA	UUCUUIUUIUUGCAAUAAAUAAGAA	844
35029	TGFBR1:799L19 (781C) palindrome siRNA	CGAACGUUCUUCUCUAGAGAGAAACGUGUUCG	845
35030	TGFBR1:797L17 (781C) palindrome siRNA	AACGUUCUUCUCUAGAGAGAAACGUGU	846
35031	TGFBR1:797L19 (779C) v1 palindrome siRNA	AACGUUCUUCUCUAGAGAGAAACGUGU	847
35032	TGFBR1:1353L19 (1335C) palindrome siRNA	AGUUGUAUUCUUAUGAAGAUUACCAACU	848
35033	TGFBR1:164L19 (1623C) palindrome siRNA	AAACCCAGGACGAGUCUUCUGGGUUU	849
35034	TGFBR1:178L19 (160C) palindrome siRNA	UAACGCCGUCGCCGCCGCCGCCGCGUUA	850
35035	TGFBR1:215L19 (197C) palindrome siRNA	UAAAUIUGUCUUUUGUACAAAAGACAAUUUA	851
35036	TGFBR1:213L17 (197C) v1 palindrome siRNA	AAUUGUCUUUUGUACAGAAAGACAAUUUA	852
35037	mTGFBR1:3964L19 (3946C) palindrome siRNA	AUUACAUAGAAAUUUUUCUAUGUAAU	853
35038	mTGFBR1:2576L19 (2558C) palindrome siRNA	AAACACUCUUUGAUCAAAAGCAGUGUUU	854
35039	mTGFBR1:2927L19 (2909C) palindrome siRNA	UCUACUCAGAAUAGCUUUAUCUGAGUAGA	855
35040	mTGFBR1:3955L19 (3937C) palindrome siRNA	AAUUIUUCUUAUUUAGAGAAAAUUUU	856
35041	mTGFBR1:5558L19 (5540C) palindrome siRNA	UACACAUACAUAUGUACAUUGUJUGUJA	857
35042	mTGFBR1:934L19 (916C) palindrome siRNA	UGUGGACAGAGCAAGCUUGCUCUGUCACACA	858
35043	mTGFBR1:1929L19 (1911C) palindrome siRNA	AACCAAGGAAACACUAGUGUUUCUUGGUU	859
35044	mTGFBR1:2063L19 (2045C) palindrome siRNA	UGUGAAGGAGCUGUGCACAGCUCUUCACACA	860
35045	mTGFBR1:2887L19 (2869C) palindrome siRNA	CAACGUGGCACUGAAUUCAGUGCCACCGUUG	861
35046	mTGFBR1:2886L18 (2869C) palindrome siRNA	AACGUGGCACUGAAUUCAGUGCCACCGU	862
35047	mTGFBR1:3437L19 (3419C) palindrome siRNA	ACAUUGAUGAAAUCAUGAUUUCAUCAAAUGU	863
35048	mTGFBR1:3684L19 (3666C) palindrome siRNA	AAACCCAUUUCUUGCAAGGAAUUGGGUUU	864
35191	HBV:243U20c + HBV:263U21 stab00 siRNA	UGUCUCAGAUUCUGAGCACCA GGACUUCUCUCAUUUUUCUTT	865
35192	HBV:245U18c + HBV:263U21 stab00 siRNA	UCUCAGAUUCUGAGCACCA GGACUUCUCUCAUUUUUCUTT	866
35193	HBV:247U16c + HBV:263U21 stab00 siRNA	UCAGAUUCUGAGCACCA GGACUUCUCUCAUUUUUCUTT	867
35194	HBV:249U14c + HBV:263U21 stab00 siRNA	AGAUUCUGAGCACCA GGACUUCUCUCAUUUUUCUTT	868
35195	HBV:250U13c + HBV:263U21 stab00 siRNA	GAUCUGAGCACCA GGACUUCUCUCAUUUUUCUTT	869

MBHB 03-465-E; (400/160)

35196	HBV:251U12c + HBV:263U21 stab00 siRNA	AUCUGAGCACCA GGACUUCUCUCAUUUUUCUTT	870
35197	HBV:252U11c + HBV:263U21 stab00 siRNA	UCUGAGCACCA GGACUUCUCUCAUUUUUCUTT	871
35198	HBV:253U10c + HBV:263U21 stab00 siRNA	CUGAGCACCA GGACUUCUCUCAUUUUUCUTT	872
35199	HBV:254U9c + HBV:263U21 stab00 siRNA	UGAGCACCA GGACUUCUCUCAUUUUUCUTT	873
35200	HBV:255U8c + HBV:263U21 stab00 siRNA	GAGCACCA GGACUUCUCUCAUUUUUCUTT	874
35201	HBV:256U7c + HBV:263U21 stab00 siRNA	AGCACCA GGACUUCUCUCAUUUUUCUTT	875
35202	HBV:257U6c + HBV:263U21 stab00 siRNA	GCACCA GGACUUCUCUCAUUUUUCUTT	876
35203	HBV:258U5c + HBV:263U21 stab00 siRNA	CACCA GGACUUCUCUCAUUUUUCUTT	877
35204	HBV:259U4c + HBV:263U21 stab00 siRNA	ACCA GGACUUCUCUCAUUUUUCUTT	878
35205	HBV:260U3c + HBV:263U21 stab00 siRNA	CCA GGACUUCUCUCAUUUUUCUTT	879
35206	HBV:261U2c + HBV:263U21 stab00 siRNA	CA GGACUUCUCUCAUUUUUCUTT	880
35207	HBV:262U1c + HBV:263U21 stab00 siRNA	A GGACUUCUCUCAUUUUUCUTT	881
35208	HBV:281L21 (263C) + HBV:262L20r stab00 siRNA	AGAAAUUUGAGAGAAGUCC UGGUGCUCAGAUUCUGAGACATT	882
35209	HBV:281L21 (263C) + HBV:262L18r stab00 siRNA	AGAAAUUUGAGAGAAGUCC UGGUGCUCAGAUUCUGAGACATT	883
35210	HBV:281L21 (263C) + HBV:262L16r stab00 siRNA	AGAAAUUUGAGAGAAGUCC UGGUGCUCAGAUUCUGAGACATT	884
35211	HBV:281L21 (263C) + HBV:262L14r stab00 siRNA	AGAAAUUUGAGAGAAGUCC UGGUGCUCAGAUUCUTT	885
35212	HBV:281L21 (263C) + HBV:262L13r stab00 siRNA	AGAAAUUUGAGAGAAGUCC UGGUGCUCAGAUUCUTT	886
35213	HBV:281L21 (263C) + HBV:262L12r stab00 siRNA	AGAAAUUUGAGAGAAGUCC UGGUGCUCAGAUUTT	887
35214	HBV:281L21 (263C) + HBV:262L11r stab00 siRNA	AGAAAUUUGAGAGAAGUCC UGGUGCUCAGATT	888
35215	HBV:281L21 (263C) + HBV:262L10r stab00 siRNA	AGAAAUUUGAGAGAAGUCC UGGUGCUCAGTT	889
35216	HBV:281L21 (263C) + HBV:262L9r stab00 siRNA	AGAAAUUUGAGAGAAGUCC UGGUGCUCATT	890
35217	HBV:281L21 (263C) + HBV:262L8r stab00 siRNA	AGAAAUUUGAGAGAAGUCC UGGUGCUCTT	891
35218	HBV:281L21 (263C) + HBV:262L7r stab00 siRNA	AGAAAUUUGAGAGAAGUCC UGGUGCUUTT	892
35219	HBV:281L21 (263C) + HBV:262L6r stab00 siRNA	AGAAAUUUGAGAGAAGUCC UGGUGCTT	893
35220	HBV:281L21 (263C) + HBV:262L5r stab00 siRNA	AGAAAUUUGAGAGAAGUCC UGGUGTT	894
35221	HBV:281L21 (263C) + HBV:262L4r stab00 siRNA	AGAAAUUUGAGAGAAGUCC UGGTT	895
35222	HBV:281L21 (263C) + HBV:262L3r stab00 siRNA	AGAAAUUUGAGAGAAGUCC UGGTT	896
35223	HBV:281L21 (263C) + HBV:262L2r stab00 siRNA	AGAAAUUUGAGAGAAGUCC UGT	897
35224	HBV:281L21 (263C) + HBV:262L1r stab00 siRNA	AGAAAUUUGAGAGAAGUCC UTT	898
35225	HCVa:327 siRNA stab0/0 Pal01	GGUCUACGAGACCCUCCCG CCGGGAGGUCUCGUAGACC	899
35226	HCVa:327 siRNA stab0/0 Pal02	GGUCUACGAGACCCUCCCG CCGGGAGGUCUCGUAGACCTT	900
35227	HCVa:327 siRNA stab0/0 Pal03	GGUCUACGAGACCCUCCCG CCGGGAGGUCUCGUAGACC	901
35228	HCVa:327 siRNA stab0/0 Pal04	GGUCUACGAGACCCUCCCG CCGGGAGGUCUCGUAGACCTT	902
35229	HCVa:327 siRNA stab0/0 Pal05	GGUCUACGAGACCCUCC CCGGGAGGUCUCGUAGACC	903
35230	HCVa:327 siRNA stab0/0 Pal06	GGUCUACGAGACCCUCC CCGGGAGGUCUCGUAGACCTT	904
35231	HCVa:327 siRNA stab0/0 Pal07	GGUCUACGAGACCCUCC CCGGGAGGUCUCGUAGACC	905
35232	HCVa:327 siRNA stab0/0 Pal08	GGUCUACGAGACCCUCC CCGGGAGGUCUCGUAGACCTT	906
35235	HCVa:327 siRNA stab0/0 Pal11	GUCUACGAGACCCUCCCG GAGGUCUCGUAGACC	907

MBHB 03-465-E; (400/160)

35236	HCVa:327 siRNA stab0/0 Pal12	GUCUACGAGACCUCCGG GAGGUCUCGUAGACTT	908
35237	HCVa:327 siRNA stab0/0 Pal13	UCUACGAGACCUCCGG GAGGUCUCGUAGA	909
35238	HCVa:327 siRNA stab0/0 Pal14	UCUACGAGACCUCCGG GAGGUCUCGUAGATT	910
35239	HCVa:327 siRNA stab0/0 Pal15	CUACGAGACCUCCGG GAGGUCUCGUAG	911
35240	HCVa:327 siRNA stab0/0 Pal16	CUACGAGACCUCCGG GAGGUCUCGUAGTT	912
35241	HCVa:327 siRNA stab0/0 Pal17	GGUUCACGAGACCUCCAG UCUCGUAGACC	913
35242	HCVa:327 siRNA stab0/0 Pal18	GGUUCACGAGACCUCCAG UCUCGUAGACCTT	914
35243	HCVa:327 siRNA stab0/0 Pal19	GGUUCACGAGACCUCCAG UCUCGUAGACC	915
35244	HCVa:327 siRNA stab0/0 Pal20	GGUUCACGAGACCUCCAG UCUCGUAGACCTT	916
35245	HCVa:327 siRNA stab0/0 Pal21	GGUUCACGAGACCUCCAG UCUCGUAGACC	917
35246	HCVa:327 siRNA stab0/0 Pal22	GGUUCACGAGACCUCCAG UCUCGUAGACCTT	918
35247	HCVa:304 siRNA stab0/0 Pal01	GACUJUCCACGAAACGCUC GAGCGUUCGUGGGAUAGUCTT	919
35248	HCVa:304 siRNA stab0/0 Pal02	GACUJUCCACGAAACGCUC GAGCGUUCGUGGGAUAGUC	920
35249	HCVa:304 siRNA stab0/0 Pal03	GACUJUCCACGAAACGCUC UCUGGGGAUAGUCTT	921
35250	HCVa:304 siRNA stab0/0 Pal04	GACUJUCCACGAAACGCUC UCUGGGGAUAGUC	922
35251	HCVa:304 siRNA stab0/0 Pal05	GACUJUCCACGAAACGCUC UCUGGGGAUAGUCTT	923
35252	HCVa:304 siRNA stab0/0 Pal06	GACUJUCCACGAAACGCUC UCUGGGGAUAGUC	924
35253	HCVa:304 siRNA stab0/0 Pal07	ACUJUCCACGAAACGCUC UCUGGGGAUAGUCTT	925
35254	HCVa:304 siRNA stab0/0 Pal08	ACUJUCCACGAAACGCUC UCUGGGGAUAGUCTT	926
35295	Luc3/rLuc bf-1a siRNA [Luc3:98L19 (80C) -6 +rLuc:231U19]	UAUCUJUCAUAGCCUUUUUGGUAUUGGGCAAA	927
35296	Luc3/rLuc bf-2a siRNA [Luc3:1562L19 (1544C) -3 +rLuc:165U19]	UCGUGCCAAAACACAAACUCUJUUAUUUUGGCGA	928
35297	Luc3/rLuc bf-3a siRNA [Luc3:1306L19 (1288C) -5 +rLuc:84U19]	CAACGAUGAAGAAGUGUUCUUGAUUCAUUUUUU	929
35298	Luc3/rLuc bf-4a siRNA [Luc3:286L19 (268C) -5 +rLuc:375U19]	ACGGCCCAACACCCGGCAUUUCAUUUAUAGCUAU	930
35299	Luc3/rLuc bf-5a siRNA [Luc3:98L19 (80C) +rLuc:84U19]	UAUCUJUCAUAGCCUUU UGUUCUUGAUUCAUUUUUU	931
35300	Luc3/rLuc bf-6a siRNA [Luc3:98L19 (80C) -4 +rLuc:84U19]	UAUCUJUCAUAGCCUU UUCUUUGAUUCAUUUUUU	932
35301	Luc3/rLuc bf-7a siRNA [Luc3:98L19 (80C) +rLuc:375U19]	UAUCUJUCAUAGCCUUU GGCAUUUCAUUUAUAGCUAU	933
35302	Luc3/rLuc bf-8a siRNA [Luc3:1562L19 (1544C) +rLuc:84U19]	UCGUGCCAAAACACCAACUC UGUUCUUGAUUCAUUUUUU	934
35303	Luc3/rLuc bf-9a siRNA [Luc3:1562L19 (1544C) -4 +rLuc:84U19]	UCGUGCCAAAACACCAAC UCUCUUGAUUCAUUUUUU	935
35304	Luc3/rLuc bf-10a siRNA [Luc3:1562L19 (1544C) +rLuc:375U19]	UCGUGCCAAAACACCAACUC GGCAUUUCAUUUAUAGCUAU	936
35305	Luc3/rLuc bf-1b siRNA [rLuc:249L19 (231C) -6 +Luc3:80U19]	UUUGCCCAUACCAAAUAGGCUAUGAAGAGAUUA	937
35306	Luc3/rLuc bf-2b siRNA [rLuc:183L19 (165C) -3 +Luc3:1544U19]	UCGCCAUAAUUAAGAAGAGUUGUUGUUUUGGACGA	938

MBHB 03-465-E; (400/160)

35307	Luc3/rLuc bf-3b siRNA [rLuc:102L19 (84C) -5 +Luc3:1288U19]	AUAAAUGAAUCAAGAACACUUCUUCUUCUUCUUG	939
35308	Luc3/rLuc bf-4b siRNA [rLuc:393L19 (375C) -5 +Luc3:268U19]	AUAGCUAAUAUGAAAUCCGGUGUUGGGCGCGU	940
35309	Luc3/rLuc bf-5b siRNA [rLuc:102L19 (84C) +Luc3:80U19]	AUAAAUGAAUCAAGAACAAUAAGGCUAUGAAGAGAU	941
35310	Luc3/rLuc bf-6b siRNA [rLuc:102L19 (84C) -4 +Luc3:80U19]	AUAAAUGAAUCAAGAAAGGCUAUGAAGAGAU	942
35311	Luc3/rLuc bf-7b siRNA [rLuc:393L19 (375C) +Luc3:80U19]	AUAGCUAAUAUGAAAUAGCCAUAAAGGCUAUGAAGAGAU	943
35312	Luc3/rLuc bf-8b siRNA [rLuc:102L19 (84C) +Luc3:1544U19]	AUAAAUGAAUCAAGAACAGAGUUGUUGUUGGGACGA	944
35313	Luc3/rLuc bf-9b siRNA [rLuc:102L19 (84C) -4 +Luc3:1544U19]	AUAAAUGAAUCAAGAAAGUUGUUGUUGGGACGA	945
35314	Luc3/rLuc bf-10b siRNA [rLuc:393L19 (375C) +Luc3:1544U19]	AUAGCUAAUAUGAAAUAGCCGAGUUGUUGUUGGGACGA	946
35913	PRKCA:1143U21 siRNA stab00	GGAUGUGGUGAUUCAGGAUUTT	947
36002	VEGF:162U21 siRNA stab00 (sense)	CCUCUUCUUUUUUCUUAAAATT	948
36003	VEGF:163U21 siRNA stab00 (sense)	CUCUUCUUUUUUCUUAAAATT	949
36004	VEGF:164U21 siRNA stab00 (sense)	UCUUCUUUUUUCUUAAAATT	950
36005	VEGF:166U21 siRNA stab00 (sense)	UUCUUUUUUUUCUUAAAATT	951
36006	VEGF:169U21 siRNA stab00 (sense)	UUUUUCUUAAAACAUUUUUTT	952
36007	VEGF:171U21 siRNA stab00 (sense)	UUUUUCUUAAAACAUUUUUTT	953
36008	VEGF:172U21 siRNA stab00 (sense)	UUUUUCUUAAAACAUUUUUTT	954
36009	VEGF:181U21 siRNA stab00 (sense)	UUUUUCUUAAAACAUUUUUTT	955
36010	VEGF:187U21 siRNA stab00 (sense)	CAUUUUUUUUUAAAACUGUUTT	956
36011	VEGF:188U21 siRNA stab00 (sense)	UUUUAAAACUGUAUUUGUUTT	957
36012	VEGF:192U21 siRNA stab00 (sense)	UUUUAAAACUGUAUUUGUUTT	958
36013	VEGF:202U21 siRNA stab00 (sense)	AAAACUGUAUUUUUCUCGTT	959
36014	VEGF:220U21 siRNA stab00 (sense)	UGUUUCUGUUUUJAAUUUATT	960
36015	VEGF:237U21 siRNA stab00 (sense)	AUUUUUGCUUGCCAUUCCCTT	961
36016	VEGF:238U21 siRNA stab00 (sense)	CCCACUUGAAUJCGGGCCGATT	962
36017	VEGF:238U21 siRNA stab00 (sense)	CCACUUGAAUJCGGGCCGATT	963
36018	VEGF:338U21 siRNA stab00 (sense)	CCAGAGAGAAUGUCGAGGAATT	964
36019	VEGF:339U21 siRNA stab00 (sense)	CAGAGAGAAGUCGAGGAATT	965
36020	VEGF:371U21 siRNA stab00 (sense)	CAGAGAGCGCGGGCGGTT	966
36021	VEGF:484U21 siRNA stab00 (sense)	AGCUGACCAGUCGCGCUGATT	967
36022	VEGF:598U21 siRNA stab00 (sense)	CCGGAGCCCGCCCGGGAGTT	968
36023	VEGF:599U21 siRNA stab00 (sense)	CGGAGCCCGCCCGGGAGTT	969
36024	VEGF:600U21 siRNA stab00 (sense)	GGAGCCCGCCCGGGAGGCTT	970
36024	VEGF:652U21 siRNA stab00 (sense)	CUGAAACUUUUUCGUCCAACTT	971
36025	VEGF:653U21 siRNA stab00 (sense)	UGAAACUUUUUCGUCCAACTT	971

МВНВВ 03-465-Е; (400/160)

36026	VEGF:654U21 siRNA stab00 (sense)	GAACUUUUCGUCCAACUUTT	972
36027	VEGF:658U21 siRNA stab00 (sense)	CUUUUCGUCCAACUUCUGGTT	973
36028	VEGF:672U21 siRNA stab00 (sense)	UCUGGGCUUUCUCGCUUCTT	974
36029	VEGF:674U21 siRNA stab00 (sense)	UGGGCUUUCUCGCUUCGGTT	975
36030	VEGF:691U21 siRNA stab00 (sense)	GGAGGAGCCGUGGUCGCGGTT	976
36031	VEGF:692U21 siRNA stab00 (sense)	GAGGAGCCGUGGUCGCGCTT	977
36032	VEGF:758U21 siRNA stab00 (sense)	GGGAGGAGCCGAGCCGGATT	978
36033	VEGF:759U21 siRNA stab00 (sense)	GGAGGAGCCGAGCCGGATT	979
36034	VEGF:760U21 siRNA stab00 (sense)	GAGGAGCCGAGCCGGAGTT	980
36035	VEGF:795U21 siRNA stab00 (sense)	GAGGAGCCGAGCCGGAGTT	981
36036	VEGF:886U21 siRNA stab00 (sense)	AGAGAAAGGAGGAGAGGTT	982
36037	VEGF:977U21 siRNA stab00 (sense)	GCUCCAGCCGCGCGCUCTT	983
36038	VEGF:978U21 siRNA stab00 (sense)	CCCACAGCCGAGCCGGGATT	984
36039	VEGF:1038U21 siRNA stab00 (sense)	CCACAGCCGAGCCGGGATT	985
36040	VEGF:1043U21 siRNA stab00 (sense)	CAUGAACUUUCUGCUCUUTT	986
36041	VEGF:1049U21 siRNA stab00 (sense)	ACUUUCGUCGUCUUGGGTT	987
36042	VEGF:1061U21 siRNA stab00 (sense)	UGCUGUCUUGGGUGCAUUGTT	988
36043	VEGF:1072U21 siRNA stab00 (sense)	UGCAUUGGAGCCUUGCCUUTT	989
36044	VEGF:1088U21 siRNA stab00 (sense)	CUUGCCUUUGCUCUCUACCTT	990
36045	VEGF:1089U21 siRNA stab00 (sense)	ACCUCACCAGUCCAAAGUUTT	991
36046	VEGF:1095U21 siRNA stab00 (sense)	CCUCCACCAGUCCAAAGUUTT	992
36047	VEGF:1110U21 siRNA stab00 (sense)	CCAUGCCAAUGUGUCCCGATT	993
36048	VEGF:1175U21 siRNA stab00 (sense)	CCAGGCUGACCCCAUGGCATT	994
36049	VEGF:1220U21 siRNA stab00 (sense)	UCUAUCAGCCGAGCUCUAGTT	995
36050	VEGF:1253U21 siRNA stab00 (sense)	UCUUCAGGAGUACCCUGATT	996
36051	VEGF:1300U21 siRNA stab00 (sense)	UCUUCAAGCCAUCCUUGUUTT	997
36052	VEGF:1309U21 siRNA stab00 (sense)	AAUGACGAGGGCCUGGAGUUTT	998
36053	VEGF:1326U21 siRNA stab00 (sense)	GGCCUGGAGUGUGUCCCATTT	999
36054	VEGF:1338U21 siRNA stab00 (sense)	CACUGAGGAGUCCAAACUUTT	1000
36055	VEGF:1342U21 siRNA stab00 (sense)	CAACAUCACCAUGCAGAUUTT	1001
36056	VEGF:1351U21 siRNA stab00 (sense)	AUCACCAUGCAGAUUAGUUTT	1002
36057	VEGF:1352U21 siRNA stab00 (sense)	CAGAUUUGCCGAUCAAACTT	1003
36058	VEGF:1353U21 siRNA stab00 (sense)	AGAUUUGCCGGAUCAAACTT	1004
36059	VEGF:1389U21 siRNA stab00 (sense)	GAUUUUGCCGGAUCAAACTT	1005
36060	VEGF:1398U21 siRNA stab00 (sense)	AGGAGAGAUUGGCUUCUUTT	1006
36061	VEGF:1401U21 siRNA stab00 (sense)	GAGCUUCCUACAGCACAACCTT	1007
36062	VEGF:1407U21 siRNA stab00 (sense)	CUUCCUACAGCACAACAATT	1008
36063	VEGF:1408U21 siRNA stab00 (sense)	ACAGCACAACAUAUGUAATT	1009
		CAGCACACAUAUGUGAAUUTT	

MBHB 03-465-E; (400/160)

36064	VEGF:1417U21 siRNA (stab00 (sense))	AAAUGUGAAUUCAGACCAATT	1010
36065	VEGF:180L21 siRNA (162C) stab00 (antisense)	UUUUAAGAAAAAAGAAAGAGTT	1011
36066	VEGF:181L21 siRNA (163C) stab00 (antisense)	GUUUUAGAAAAAAGAAAGAGTT	1012
36067	VEGF:182L21 siRNA (164C) stab00 (antisense)	UGUUUAAAGAAAAAAGAAAGATT	1013
36068	VEGF:184L21 siRNA (166C) stab00 (antisense)	AAUGUUUAAAGAAAAAAGAAATT	1014
36069	VEGF:187L21 siRNA (169C) stab00 (antisense)	AAAAAUGUUUAAAGAAAAAATT	1015
36070	VEGF:189L21 siRNA (171C) stab00 (antisense)	AAAAAAAUGUUUAAAGAAAAATT	1016
36071	VEGF:190L21 siRNA (172C) stab00 (antisense)	AAAAAAAUGUUUAAAGAAAAATT	1017
36072	VEGF:199L21 siRNA (181C) stab00 (antisense)	ACAGUUUUUAAAAAAGAAUGTT	1018
36073	VEGF:205L21 siRNA (187C) stab00 (antisense)	AACAAUACAGUUUUUAAAAAATT	1019
36074	VEGF:206L21 siRNA (188C) stab00 (antisense)	AAACAAUACAGUUUUUAAAAAATT	1020
36075	VEGF:210L21 siRNA (192C) stab00 (antisense)	CGAGAAAAAAUACAGUUUUUUTT	1021
36076	VEGF:220L21 siRNA (202C) stab00 (antisense)	UAAUUUAAAAACGAGAAACATT	1022
36077	VEGF:238L21 siRNA (220C) stab00 (antisense)	GGGAAUGGCAAGCAAAAAUUTT	1023
36078	VEGF:255L21 siRNA (237C) stab00 (antisense)	UCGGCCCGAUUCAAGUGGGTT	1024
36079	VEGF:256L21 siRNA (238C) stab00 (antisense)	GUCGGCCCGAUUCAAGUGGGTT	1025
36080	VEGF:356L21 siRNA (338C) stab00 (antisense)	UUCCUJGACUUCUCUCUGGTT	1026
36081	VEGF:357L21 siRNA (339C) stab00 (antisense)	CUUCCUJGACUUCUCUCUGGTT	1027
36082	VEGF:399L21 siRNA (371C) stab00 (antisense)	CGCCCGCGCGUCUCUCUGTT	1028
36083	VEGF:502L21 siRNA (484C) stab00 (antisense)	UCAGCGGACUJGGUCAGCUTT	1029
36084	VEGF:616L21 siRNA (598C) stab00 (antisense)	CUCCGGCGCGGGCUCGCCGTT	1030
36085	VEGF:617L21 siRNA (599C) stab00 (antisense)	CCUCCGGCGCGGGCUCGCCGTT	1031
36086	VEGF:618L21 siRNA (600C) stab00 (antisense)	GCCUCCGGCGCGGGCUCGCCTT	1032
36087	VEGF:670L21 siRNA (652C) stab00 (antisense)	GUJGGACGAAAAAGUUUCAGTT	1033
36088	VEGF:671L21 siRNA (653C) stab00 (antisense)	AGUJGGACGAAAAAGUUUCATT	1034
36089	VEGF:672L21 siRNA (654C) stab00 (antisense)	AAGUJGGACGAAAAAGUUUCATT	1035
36090	VEGF:676L21 siRNA (658C) stab00 (antisense)	CCAGAAUUGGACGAAAAAGTT	1036
36091	VEGF:690L21 siRNA (672C) stab00 (antisense)	GAAGCGAGAACAGCCCAGATT	1037
36092	VEGF:692L21 siRNA (674C) stab00 (antisense)	CCGAAAGCGAGAACAGCCCATT	1038
36093	VEGF:709L21 siRNA (691C) stab00 (antisense)	CGCGGACACGGGUCUCCUCCTT	1039
36094	VEGF:710L21 siRNA (692C) stab00 (antisense)	GCGCGGACACGGGUCUCCUCCTT	1040
36095	VEGF:776L21 siRNA (758C) stab00 (antisense)	UCCGGCUGCGGGCUCUCCUCCTT	1041
36096	VEGF:777L21 siRNA (759C) stab00 (antisense)	CUCCGGCUGCGGGCUCUCCUCCTT	1042
36097	VEGF:778L21 siRNA (760C) stab00 (antisense)	CCUCCGGCUGCGGGCUCUCCUCCTT	1043
36098	VEGF:813L21 siRNA (795C) stab00 (antisense)	CCUCCUCUUCUCCUUCUCUCCUCCTT	1044
36099	VEGF:904L21 siRNA (886C) stab00 (antisense)	GAGCGCGCGCGGUCUGGAGCATT	1045
36100	VEGF:995L21 siRNA (977C) stab00 (antisense)	CUCCGGCUGCGGGCUCUGGGTT	1046
36101	VEGF:996L21 siRNA (978C) stab00 (antisense)	UCUCCGGCUCGGGUCUGGGTT	1047

MBHB 03-465-E; (400/160)

36102	VEGF:1056L21 siRNA (1038C) stab00 (antisense)	AGACAGCAGAAAGUUUCAUGTT	1048
36103	VEGF:1061L21 siRNA (1043C) stab00 (antisense)	ACCCAAAGACAGCAGAAAGUUTT	1049
36104	VEGF:1067L21 siRNA (1049C) stab00 (antisense)	CAAUGCACCCCAAGACAGCATT	1050
36105	VEGF:1079L21 siRNA (1061C) stab00 (antisense)	AAGGCAAGGCCUCCAAUUGCATT	1051
36106	VEGF:1090L21 siRNA (1072C) stab00 (antisense)	GGUAGAGCAGCAAGGCAAGTT	1052
36107	VEGF:1106L21 siRNA (1088C) stab00 (antisense)	CACUUGGCAUGGUGGAGGUTT	1053
36108	VEGF:1107L21 siRNA (1089C) stab00 (antisense)	CCACUUGGCAUGGUGGAGGTT	1054
36109	VEGF:1113L21 siRNA (1095C) stab00 (antisense)	CUGGGACCACUUUGGCAUGGTT	1055
36110	VEGF:1128L21 siRNA (1110C) stab00 (antisense)	UGCCAUUGGGUGCAGCCUGGTT	1056
36111	VEGF:1193L21 siRNA (1175C) stab00 (antisense)	CAGUAGCUGCGCUGAUAGATT	1057
36112	VEGF:1238L21 siRNA (1220C) stab00 (antisense)	UCAGGGUACUCCUGGAAGATT	1058
36113	VEGF:1271L21 siRNA (1253C) stab00 (antisense)	ACACAGGAUGGCCUUGAAGATT	1059
36114	VEGF:1318L21 siRNA (1300C) stab00 (antisense)	ACUCCAGGCCUCCUGUCAUUTT	1060
36115	VEGF:1327L21 siRNA (1309C) stab00 (antisense)	UGGGCACACAUCCAGGCCCTT	1061
36116	VEGF:1344L21 siRNA (1326C) stab00 (antisense)	GAUJUUGGACUCCUCCAGUGTT	1062
36117	VEGF:1356L21 siRNA (1338C) stab00 (antisense)	AAUCUGCAUUGGUGAUUGUUTT	1063
36118	VEGF:1360L21 siRNA (1342C) stab00 (antisense)	GCAUAAUCUGCAUUGGUGAUUTT	1064
36119	VEGF:1369L21 siRNA (1351C) stab00 (antisense)	GUUUGAUCCGCAUUAUCUGTT	1065
36120	VEGF:1370L21 siRNA (1352C) stab00 (antisense)	GGUUUGAUCCGCAUUAUCUTT	1066
36121	VEGF:1371L21 siRNA (1353C) stab00 (antisense)	AGUUUGAUCCGCAUUAUCUTT	1067
36122	VEGF:1407L21 siRNA (1389C) stab00 (antisense)	UAGGAAGCUCAUCUCUCCUTT	1068
36123	VEGF:1416L21 siRNA (1398C) stab00 (antisense)	GUUGUUGUUAAGGAAAGCUCUTT	1069
36124	VEGF:1419L21 siRNA (1401C) stab00 (antisense)	UUUGUUUGUUGGUGUAGGAAGTT	1070
36125	VEGF:1425L21 siRNA (1407C) stab00 (antisense)	UUCACAUUUUGUUGGUGCUGUTT	1071
36126	VEGF:1426L21 siRNA (1408C) stab00 (antisense)	AUJACAUUUUGUUGGUGCUGTT	1072
36127	VEGF:1435L21 siRNA (1417C) stab00 (antisense)	UUGGUCUGCAUUCACAUUUTT	1073
36408	bf-L-03 siRNA stab00 [VEGF:1215U21 o18S FLT1:346U21]	GGACAUCUCCAGGAGUACTT X GAACUGAGUUUAAAAAGGCATT	1074
36409	bf-L-02 siRNA stab00 [VEGF:1421U21 o18S FLT1:346U21]	GUGAAUUGCAGACCAAGAATT X GAACUGAGUUUAAAAAGGCATT	1075
36410	bf-L-23 siRNA stab00 [HBV:1583U21 o18S HBV:263U21]	GCACUUCGCUUCCACCUCUGTT X GGACUUCUCUCAUUUUUUCUTT	1076
36411	bf-L-04 siRNA stab00 [KDR:3854U21 o18S FLT1:346U21]	UGAGCAUUGGAAGAGGAUUCCTT X GAACUGAGUUUAAAAAGGCATT	1077
36412	bf-L-12 siRNA stab00 [Luc3:468U21 o18S Luc3:80U21]	GGAUUACAGGGAAUUCAGTT X AUAAAGGCUAUGAAGAGAUATT	1078
36413	bf-L-10 siRNA stab00 [Luc3:1544U21 o18S Luc3:80U21]	GAGUUGUUGUUUGGAGCCGATT X AUAAAGGCUAUGAAGAGAUATT	1079
36414	bf-L-21 siRNA stab00 [HCVa:327U21 o18S HCVa:282U21]	CCGGGAGGUCUCUGUAGACCCTT X GCGAAAGGCCUUUGGUGUACTT	1080
36415	bf-L-22 siRNA stab00 [HCVa:327U21 o18S HCVa:307U21]	CCGGGAGGUCUCUGUAGACCCTT X AUAGGGUGCUUGCCGAGUGCTT	1081
36416	bf-L-01 siRNA stab00 [FLT1:346U21 o18S]	GAACUGAGUUUAAAAAGGCATT X GUGAAUUGCAGACCAAGAATT	1082



MBHB 03-465-E; (400/160)

36417	VEGF:1421U21]		UGACGGAAAAAGAGAUCCGUTT X AUAAGGCCUAUGAAGAGAUATT	1083
36418	bF-L-15 siRNA stab00 [Luc3:1478U21 o18S Luc3:80U21]		UGACGGAAAAAGAGAUCCGUTT W AUAAGGCCUAUGAAGAGAUATT	1084
36419	bF-L-16 siRNA stab00 [Luc3:1478U21 c12S Luc3:80U21]		UGACGGAAAAAGAGAUCCGUTT Y AUAAGGCCUAUGAAGAGAUATT	1085
36420	bF-L-17 siRNA stab00 [Luc3:1478U21o9S Luc3:80U21]		UGACGGAAAAAGAGAUCCGUTT Z AUAAGGCCUAUGAAGAGAUATT	1086
36421	bF-L-18 siRNA stab00 [Luc3:1478U21 c3S Luc3:80U21]		UGACGGAAAAAGAGAUCCGUTT XX AUAAGGCCUAUGAAGAGAUATT	1087
36422	bF-L-19 siRNA stab00 [Luc3:1478U21 2x o18S Luc3:80U21]		AUAAGGCCUAUGAAGAGAUATT X UGACGGAAAAAGAGAUCCGUTT	1088
36423	bF-L-13 siRNA stab00 [Luc3:80U21 o18S Luc3:1478U21]		CGUAUGCAGUGAAAAACUCUTT X UGACGGAAAAAGAGAUCCGUTT	1089
36424	bF-L-14 siRNA stab00 [Luc3:237U21 o18S Luc3:1478U21]		CGUAUGCAGUGAAAAACUCUTT X AUAAGGCCUAUGAAGAGAUATT	1090
36425	bF-L-11 siRNA stab00 [Luc3:237U21 o18S Luc3:80U21]		AUGCUGGACUCCUGGCACATT X GUGAAUCCAGACCCAAAGAATT	1091
36426	bF-L-05 siRNA stab00 [FLT1:3646U21 o18S VEGF:1421U21]		AUGCUGGACUCCUGGCACATT W GUGAAUCCAGACCCAAAGAATT	1092
36427	bF-L-06 siRNA stab00 [FLT1:3646U21 c12S VEGF:1421U21]		AUGCUGGACUCCUGGCACATT Y GUGAAUCCAGACCCAAAGAATT	1093
36428	bF-L-07 siRNA stab00 [FLT1:3646U21 o9S VEGF:1421U21]		AUGCUGGACUCCUGGCACATT Z GUGAAUCCAGACCCAAAGAATT	1094
36429	bF-L-08 siRNA stab00 [FLT1:3646U21 c3S VEGF:1421U21]		AUGCUGGACUCCUGGCACATT XX GUGAAUCCAGACCCAAAGAATT	1095
36430	bF-L-09 siRNA stab00 [FLT1:3646U21 2x o18S VEGF:1421U21]		AUAGGGUJGUJCGGAGUGCTT X GCGAAAAGGCCUJUGUGGUJACTT	1096
36431	bF-L-20 siRNA stab00 [HCVa:307U21 o18S HCVa:282U21]		GAACUGAGUUUAAAAAGGCCATT	1097
36432	FLT1:346U21 siRNA stab00 (sense)		AUAAGGCCUAUGAAGAGAUATT	1098
36433	Luc3:80U21 siRNA stab00 (sense)		UGACGGAAAAAGAGAUCCGUTT	1099
36434	Luc3:1478U21 siRNA stab00 (sense)		GAGUUGUUUUGUGGACGATT	1100
36435	Luc3:1544U21 siRNA stab00 (sense)		CGUAUGCAGUGAAAAACUCUTT	1101
36436	Luc3:237U21 siRNA stab00 (sense)		GGAUUACCAGGGGUAUUUCAGTT	1102
36437	Luc3:468U21 siRNA stab00 (sense)		GCGAAAAGGCCUJUGUGGUJACTT	1103
36438	HCVa:282U21 siRNA stab00 (sense)		AUAGGGUJGUJCGGAGUGCTT	1104
36439	HCVa:307U21 siRNA stab00 (sense)		UGCCUUUUAAAACUCAGUUUCTT	1105
36440	FLT1:364L21 siRNA (346C) stab00 (antisense)		UAUCUUCUAUAGCCUUUAUTT	1106
36441	Luc3:98L21 siRNA (80C) stab00 (antisense)		ACGAUCUUCUUUUCCGUCATT	1107
36442	Luc3:1496L21 siRNA (1478C) stab00 (antisense)		UCGUCCACAAAACACAACUCCTT	1108
36443	Luc3:1562L21 siRNA (1544C) stab00 (antisense)		AGAGUUUUCACUJGCAUACGTT	1109
36444	Luc3:255L21 siRNA (237C) stab00 (antisense)		CUGAAAUCUUUGGUAUUCCTT	1110
36445	Luc3:486L21 siRNA (468C) stab00 (antisense)		GUACCACAAGGCCUUUCGCTT	1111
36446	HCVa:300L21 siRNA (282C) stab00 (antisense)		GCACUCGCAAGCACCCUAUTT	1112
36447	HCVa:325L21 siRNA (307C) stab00 (antisense)		GGUCUACGAGACCCUCCCGGTT	1113
36447	HCVa:345L21 siRNA (327C) stab00 (antisense)			

UPPER CASE = ribonucleotide  
UPPER CASE UNDERLINE = 2'-O-methyl nucleotide  
Lowercase = 2'-deoxy-2'-fluoro nucleotide  
T = thymidine  
T = inverted thymidine  
t = 3'-deoxy thymidine  
B = inverted deoxyabasic succinate linker  
B = inverted deoxyabasic  
X = universal base (5-nitroindole)  
Z = universal base (3-nitropyrrole)  
S = phosphorothioate internucleotide linkage  
U = 5-bromodeoxyuridine  
A = deoxyadenosine  
G = deoxyguanosine  
L = glyceryl moiety  
ddC = dideoxy Cytidine  
p = phosphate

Table II

A. 2.5  $\mu$ mol Synthesis Cycle ABI 394 Instrument

Reagent	Equivalents	Amount	Wait Time* DNA	Wait Time* 2'-O-methyl	Wait Time*RNA
Phosphoramidites	6.5	163 $\mu$ L	45 sec	2.5 min	7.5 min
S-Ethyl Tetrazole	23.8	238 $\mu$ L	45 sec	2.5 min	7.5 min
Acetic Anhydride	100	233 $\mu$ L	5 sec	5 sec	5 sec
N-Methyl Imidazole	186	233 $\mu$ L	5 sec	5 sec	5 sec
TCA	176	2.3 mL	21 sec	21 sec	21 sec
Iodine	11.2	1.7 mL	45 sec	45 sec	45 sec
Beaucage	12.9	645 $\mu$ L	100 sec	300 sec	300 sec
Acetonitrile	NA	6.67 mL	NA	NA	NA

B. 0.2  $\mu$ mol Synthesis Cycle ABI 394 Instrument

Reagent	Equivalents	Amount	Wait Time* DNA	Wait Time* 2'-O-methyl	Wait Time*RNA
Phosphoramidites	15	31 $\mu$ L	45 sec	233 sec	465 sec
S-Ethyl Tetrazole	38.7	31 $\mu$ L	45 sec	233 min	465 sec
Acetic Anhydride	655	124 $\mu$ L	5 sec	5 sec	5 sec
N-Methyl Imidazole	1245	124 $\mu$ L	5 sec	5 sec	5 sec
TCA	700	732 $\mu$ L	10 sec	10 sec	10 sec
Iodine	20.6	244 $\mu$ L	15 sec	15 sec	15 sec
Beaucage	7.7	232 $\mu$ L	100 sec	300 sec	300 sec
Acetonitrile	NA	2.64 mL	NA	NA	NA

C. 0.2  $\mu$ mol Synthesis Cycle 96 well Instrument

Reagent	Equivalents:DNA/ 2'-O-methyl/Ribo	Amount: DNA/2'-O-methyl/Ribo	Wait Time* DNA	Wait Time* 2'-O-methyl	Wait Time* Ribo
Phosphoramidites	22/33/66	40/60/120 $\mu$ L	60 sec	180 sec	360sec
S-Ethyl Tetrazole	70/105/210	40/60/120 $\mu$ L	60 sec	180 min	360 sec
Acetic Anhydride	265/265/265	50/50/50 $\mu$ L	10 sec	10 sec	10 sec
N-Methyl Imidazole	502/502/502	50/50/50 $\mu$ L	10 sec	10 sec	10 sec
TCA	238/475/475	250/500/500 $\mu$ L	15 sec	15 sec	15 sec
Iodine	6.8/6.8/6.8	80/80/80 $\mu$ L	30 sec	30 sec	30 sec
Beaucage	34/51/51	80/120/120	100 sec	200 sec	200 sec
Acetonitrile	NA	1150/1150/1150 $\mu$ L	NA	NA	NA

- Wait time does not include contact time during delivery.
- Tandem synthesis utilizes double coupling of linker molecule

Table III

Group	Solution on Filter (1.0 $\mu\text{L}$ )	Stock VEGF concentration	Number of Animals	Injectate (6.0 $\mu\text{L}$ )	Dose	Conc. injectate
1	Tris-Cl pH 6.9	NA	5	water	NA	NA
2	R&D Systems VEGF-carrier free 75 $\mu\text{M}$	3.53 $\mu\text{g}/\mu\text{L}$	5	water	NA	NA
3	R&D Systems VEGF-carrier free 75 $\mu\text{M}$	3.53 $\mu\text{g}/\mu\text{L}$	5	Site 2340 Stab1 siRNA	10 $\mu\text{g}/\text{eye}$	1.67 $\mu\text{g}/\mu\text{L}$
4	R&D Systems VEGF-carrier free 75 $\mu\text{M}$	3.53 $\mu\text{g}/\mu\text{L}$	5	Site 2340 Stab1 siRNA	3 $\mu\text{g}/\text{eye}$	0.5 $\mu\text{g}/\mu\text{L}$
5	R&D Systems VEGF-carrier free 75 $\mu\text{M}$	3.53 $\mu\text{g}/\mu\text{L}$	5	Site 2340 Stab1 siRNA	1 $\mu\text{g}/\text{eye}$	0.167 $\mu\text{g}/\mu\text{L}$
6	R&D Systems VEGF-carrier free 75 $\mu\text{M}$	3.53 $\mu\text{g}/\mu\text{L}$	5	Inactive Site 2340 Stab1 siRNA	10 $\mu\text{g}/\text{eye}$	1.67 $\mu\text{g}/\mu\text{L}$
7	R&D Systems VEGF-carrier free 75 $\mu\text{M}$	3.53 $\mu\text{g}/\mu\text{L}$	5	Inactive Site 2340 Stab1 siRNA	3 $\mu\text{g}/\text{eye}$	0.5 $\mu\text{g}/\mu\text{L}$
8	R&D Systems VEGF-carrier free 75 $\mu\text{M}$	3.53 $\mu\text{g}/\mu\text{L}$	5	Inactive Site 2340 Stab1 siRNA	1 $\mu\text{g}/\text{eye}$	0.167 $\mu\text{g}/\mu\text{L}$

**Table IV**

Non-limiting examples of Stabilization Chemistries for chemically modified siNA constructs

Chemistry	pyrimidine	Purine	Cap	p=S	Strand
"Stab 00"	Ribo	Ribo	TT at 3'-ends		S/AS
"Stab 1"	Ribo	Ribo	-	5 at 5'-end 1 at 3'-end	S/AS
"Stab 2"	Ribo	Ribo	-	All linkages	Usually AS
"Stab 3"	2'-fluoro	Ribo	-	4 at 5'-end 4 at 3'-end	Usually S
"Stab 4"	2'-fluoro	Ribo	5' and 3'-ends	-	Usually S
"Stab 5"	2'-fluoro	Ribo	-	1 at 3'-end	Usually AS
"Stab 6"	2'-O-Methyl	Ribo	5' and 3'-ends	-	Usually S
"Stab 7"	2'-fluoro	2'-deoxy	5' and 3'-ends	-	Usually S
"Stab 8"	2'-fluoro	2'-O-Methyl	-	1 at 3'-end	Usually AS
"Stab 9"	Ribo	Ribo	5' and 3'-ends	-	Usually S
"Stab 10"	Ribo	Ribo	-	1 at 3'-end	Usually AS
"Stab 11"	2'-fluoro	2'-deoxy	-	1 at 3'-end	Usually AS
"Stab 12"	2'-fluoro	LNA	5' and 3'-ends		Usually S
"Stab 13"	2'-fluoro	LNA		1 at 3'-end	Usually AS
"Stab 14"	2'-fluoro	2'-deoxy		2 at 5'-end 1 at 3'-end	Usually AS
"Stab 15"	2'-deoxy	2'-deoxy		2 at 5'-end 1 at 3'-end	Usually AS
"Stab 16"	Ribo	2'-O-Methyl	5' and 3'-ends		Usually S
"Stab 17"	2'-O-Methyl	2'-O-Methyl	5' and 3'-ends		Usually S
"Stab 18"	2'-fluoro	2'-O-Methyl	5' and 3'-ends	1 at 3'-end	Usually S
"Stab 19"	2'-fluoro	2'-O-Methyl	3'-end		Usually AS
"Stab 20"	2'-fluoro	2'-deoxy	3'-end		Usually AS
"Stab 21"	2'-fluoro	Ribo	3'-end		Usually AS
"Stab 22"	Ribo	Ribo	3'-end -		Usually AS
"Stab 23"	2'-fluoro*	2'-deoxy*	5' and 3'-ends		Usually S
"Stab 24"	2'-fluoro*	2'-O-Methyl*	-	1 at 3'-end	Usually AS
"Stab 25"	2'-fluoro*	2'-O-Methyl*	-	1 at 3'-end	Usually AS

CAP = any terminal cap, see for example **Figure 10**.

All Stab 1-25 chemistries can comprise 3'-terminal thymidine (TT) residues

5 All Stab 1-25 chemistries typically comprise about 21 nucleotides, but can vary as described herein.

S = sense strand

AS = antisense strand

\*Stab 23 has single ribonucleotide adjacent to 3'-CAP

\*Stab 24 has single ribonucleotide at 5'-terminus

10 \*Stab 25 has three ribonucleotides at 5'-terminus

**Table V: Peptides for Conjugation**

Peptide	Sequence	SEQ ID NO
ANTENNAPEDIA	RQI KIW FQN RRM KWK K amide	1114
Kaposi fibroblast growth factor	AAV ALL PAV LLA LLA P + VQR KRQ KLMP	1115
<i>caiman crocodylus</i> Ig(5) light chain	MGL GLH LLV LAA ALQ GA	1116
HIV envelope glycoprotein gp41	GAL FLG FLG AAG STM GA + PKS KRK 5 (NLS of the SV40)	1117
HIV-1 Tat	RKK RRQ RRR	1118
Influenza hemagglutinin envelop glycoprotein	GLFEAIAGFIENGWEGMIDGGGYC	1119
RGD peptide	X-RGD-X where X is any amino acid or peptide	1120
transportan A	GWT LNS AGY LLG KIN LKA LAA LAK KIL	1121
Somatostatin (tyr-3-octreotate)	(S)FC YWK TCT	1122
Pre-S-peptide	(S)DH QLN PAF	1123

(S) optional Serine for coupling

5 *Italic* = optional D isomer for stability

(400/160)

**Table VI: Duplex half-lives in human and mouse serum and liver extracts**

Stability S/AS Sirna #	All RNA 47715/47933	4*/5 30355/30366	4/5* 30355/30366	7/11* 30612/31175	7*/8 30612/30620	7/8* 30612/30620
Human Serum t ½ hours	0.017	408 (0.96)†	39 (0.65)	54 (0.76)	130 (0.88)	94 (0.86)
Human Liver t ½ hours	2.5	28.6 (0.40)	43.5 (0.66)	0.78 / 2.9† (0.45)	9 (0.39)	816 (0.99)
Mouse Serum t ½ hours	1.17	16.7 (0.9)	10 (0.81)	2.3	16.6 (0.46)	35.7 (0.69)
Mouse Liver t ½ hours	6	1.08	0.80	0.20	0.22	120 (0.89)

\* The asterisk designates the strand carrying the radiolabel in the duplex.

† For longer half-lives the fraction full-length at the 18 hours is presented as the parenthetical lower number in each cell.

‡ A biphasic curve was observed, half-lives for both phases are shown.



**Table VII: Single strand half-lives in human serum**

<b>Stability Sirna #</b>	<b>4 30355</b>	<b>5 30366</b>	<b>7 30612</b>	<b>11 31175</b>	<b>8 30620</b>
<b>Human serum <math>t_{1/2}</math> hours</b>	22	16	13	19	28
<b>Human liver <math>t_{1/2}</math> hours</b>	0.92	0.40	0.43	0.27	192

5

**Table VIII. Human serum half-lives for Stab 4/5 duplex chemistry with terminus chemistries of figure 22**

Cap Chemistry	2 (R=O) (B=T)	7 (R=O) (B=T)	9 (R=O) (B=T)	2 (R=S) (B=T)	8 (R=O) (B=T)	1 (R=O) (B=T)	3 (R=O) (B=T)	6 (R=O) (B=T)
Human Serum $t_{1/2}$ hours	1	1.2	2.3	39	96 (0.69) <sup>‡</sup>	460 (0.95)	770 (0.94)	770 (0.95)

5

The capping structures were in the following position of the 4:5 chemistry formatted sequence:

antisense strand – 5'-uuGuuGuAuuuuGuGGuuG– CAP – 3' where CAP is 1, 2, 3, 6, 7, 8, or 9 from Figure 22. (SEQ ID NO: 670)

10 sense strand 5'-CAP- cAAccAcAAAuAcAAcAATT– CAP – 3' where CAP is 1 from Figure 22. (SEQ ID NO: 671)

<sup>‡</sup> For half-lives that extend beyond the time course sampled the fraction full-length is presented in parentheses.

The claims defining the invention are as follows:

1. A multifunctional siNA molecule comprising a structure having Formula MF-III:



wherein

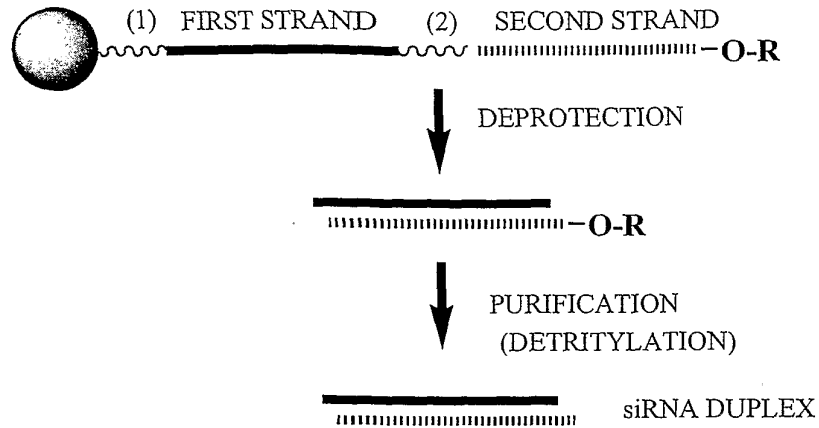
- 5 (a) each X, X', Y, and Y' is independently an oligonucleotide of length between 15 nucleotides and 50 nucleotides;
- (b) X comprises nucleotide sequence that is complementary to nucleotide sequence present in region Y';
- (c) X' comprises nucleotide sequence that is complementary to nucleotide  
10 sequence present in region Y;
- (d) each X and X' is independently of length sufficient to stably interact with a first and a second target nucleic acid sequence, respectively, or a portion thereof;
- (e) W represents a nucleotide or non-nucleotide linker that connects  
15 sequences Y' and Y; and
- (f) said multifunctional siNA directs cleavage of the first and second target sequence via RNA interference.
2. The multifunctional siNA molecule of claim 1, wherein W connects the 5'-end of sequence Y' with the 3'-end of sequence Y.
- 20 3. The multifunctional siNA molecule of claim 1 or claim 2, wherein a terminal phosphate group is present at the 5'-end of any of sequence X, X', Y, or Y'.
4. The multifunctional siNA molecule of any one of claims 1 to 3, wherein W connects sequences Y and Y' via a biodegradable linker.
5. The multifunctional siNA molecule of any one of claims 1 to 4, wherein W further  
25 comprises a conjugate, label, aptamer, ligand, lipid, or polymer.
6. The multifunctional siNA molecule of any one of claims 1 to 5, wherein any of sequence X, X', Y, or Y' comprises a 3'-terminal cap moiety.

7. The multifunctional siNA molecule of claim 6, wherein said terminal cap moiety is an inverted deoxybasic moiety.
8. The multifunctional siNA molecule of claim 7, wherein said terminal cap moiety is an inverted deoxynucleotide moiety.
- 5 9. The multifunctional siNA molecule of claim 7, wherein said terminal cap moiety is a dinucleotide moiety.
10. The multifunctional siNA molecule of claim 9, wherein said dinucleotide is dithymidine (TT).
11. The multifunctional siNA molecule of any one of claims 1 to 10, wherein said siNA molecule comprises no ribonucleotides.
- 10 12. The multifunctional siNA molecule of any one of claims 1 to 10, wherein said siNA molecule comprises ribonucleotides.
13. The multifunctional siNA molecule of any one of claims 1 to 12, wherein one or more purine nucleotides in said siNA is a 2'-O-methyl purine nucleotide.
- 15 14. The multifunctional siNA molecule of any one of claims 1 to 12, wherein one or more purine nucleotides in said siNA is a 2'-deoxy purine nucleotide.
15. The multifunctional siNA molecule of any one of claims 1 to 14, wherein one or more pyrimidine nucleotides in said siNA is a 2'-deoxy-2'-fluoro pyrimidine nucleotide.
- 20 16. The multifunctional siNA molecule of any one of claims 1 to 15, wherein each X, X', Y, and Y' independently comprises between 19 and 23 nucleotides.
17. A pharmaceutical composition comprising the multifunctional siNA molecule of any one of claims 1 to 16 in an acceptable carrier or diluent.

**DATED 12 JUNE, 2009**  
**SIRNA THERAPEUTICS, INC.**

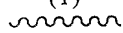
**PATENT ATTORNEYS FOR THE APPLICANT/NOMINATED PERSON**  
**SPRUSON & FERGUSON**

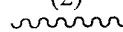
*Figure 1*

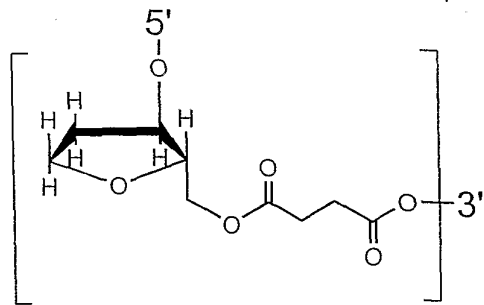


 = SOLID SUPPORT

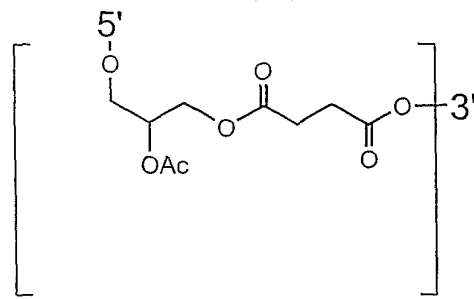
R = TERMINAL PROTECTING GROUP  
 FOR EXAMPLE:  
 DIMETHOXYTRITYL (DMT)

(1)  = CLEAVABLE LINKER  
 (FOR EXAMPLE: NUCLEOTIDE SUCCINATE OR  
 INVERTED DEOXYABASIC SUCCINATE)

(2)  = CLEAVABLE LINKER  
 (FOR EXAMPLE: NUCLEOTIDE SUCCINATE OR  
 INVERTED DEOXYABASIC SUCCINATE)

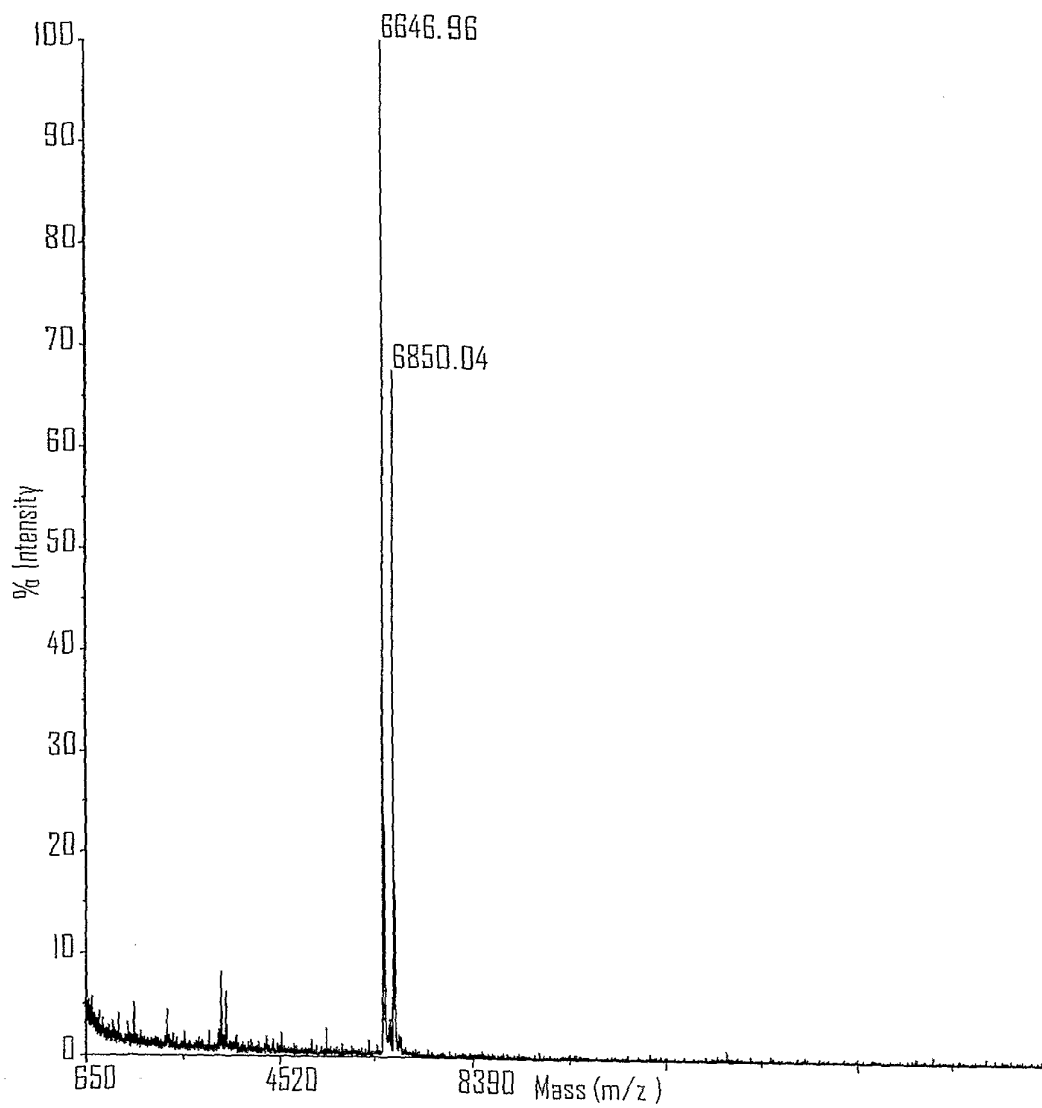


INVERTED DEOXYABASIC SUCCINATE LINKAGE



GLYCERYL SUCCINATE LINKAGE

*Figure 2*



**Figure 3**

- 5'-CGUACGGGAUAUCUUCGATT (SEQ ID NO: 394)  
3'-TTGCAUGCGCCUUAUGAAGCU (SEQ ID NO: 395)  
T 1/2 = 15 seconds (control)
- 5'-B cAaccAcAAAuAcAacAATT B (SEQ ID NO: 396)  
3'-TXGuuGGuGuuuuuAuGuuGuu (SEQ ID NO: 397 )  
T 1/2 = 138 min
- 5'-B cAaccAcAAAuAcAacAATT B (SEQ ID NO: 396)  
3'-TDGuuGGuGuuuuuAuGuuGuu (SEQ ID NO: 398 )  
T 1/2 = 3.7 days
- 5'-B cAaccAcAAAuAcAacAATT B (SEQ ID NO: 396 )  
3'-XTGuuGGuGuuuuuAuGuuGuu (SEQ ID NO: 399 )  
T 1/2 = 72 minutes
- 5'-B cAaccAcAAAuAcAacAATT B (SEQ ID NO: 396)  
3'-LTGuuGGuGuuuuuAuGuuGuu (SEQ ID NO: 400)  
T 1/2 = 40 days
- 5'-B cAaccAcAAAuAcAacAATT B (SEQ ID NO: 396)  
3'-tTGuuGGuGuuuuuAuGuuGuu (SEQ ID NO: 401)  
T 1/2 = 32 days

G, A, U, C = Guanosine, Adenosine, Uridine, Cytidine  
 T = Thymidine  
 Lower Case = 2'-deoxy-2'-fluoro  
 S = phosphorothioate  
 B = inverted deoxyabasic  
 D = inverted Thymidine  
 X = 3'-deoxy Thymidine  
 t = L-thymidine  
 L = Glyceryl moiety

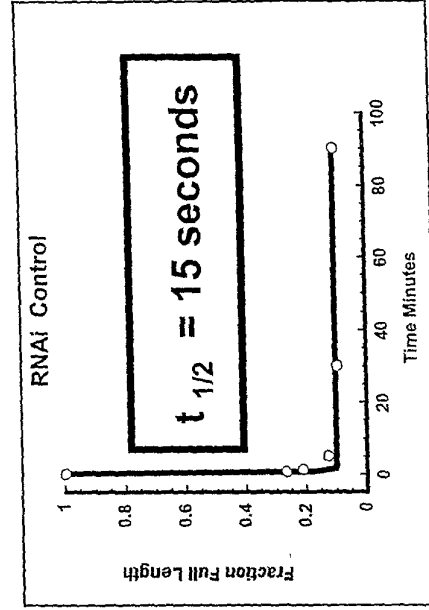


Figure 4

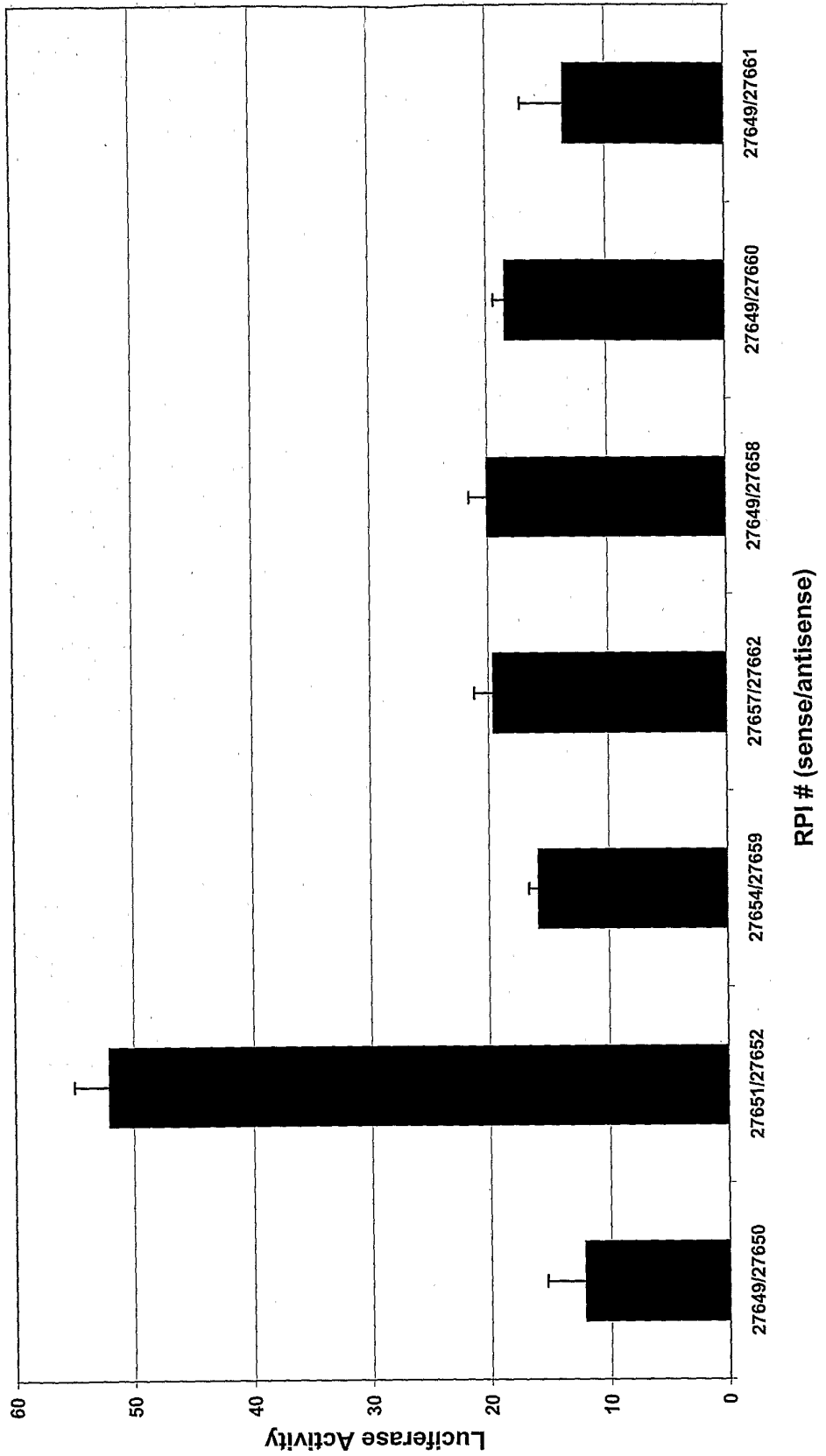




Figure 5

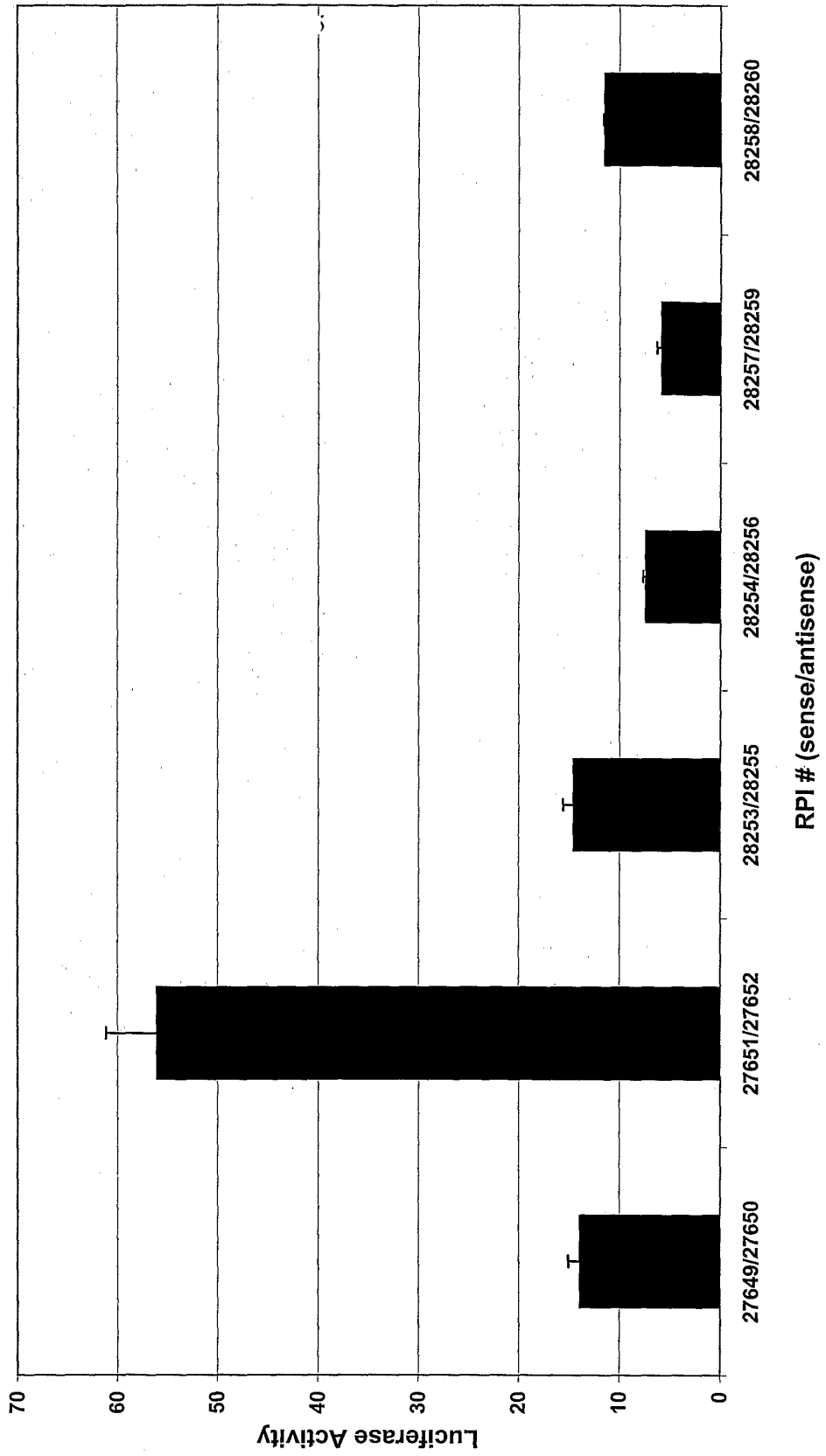


Figure 6

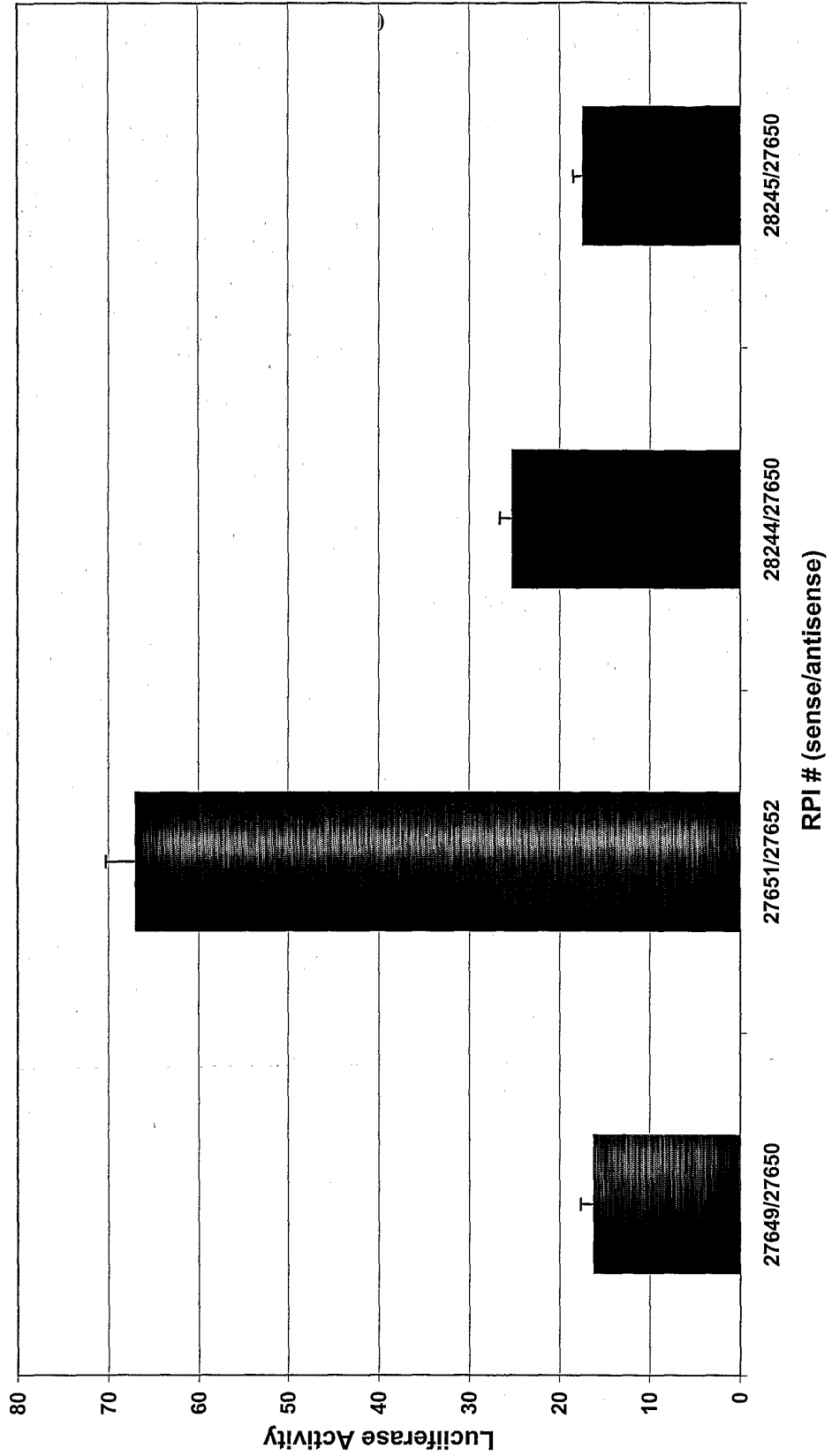
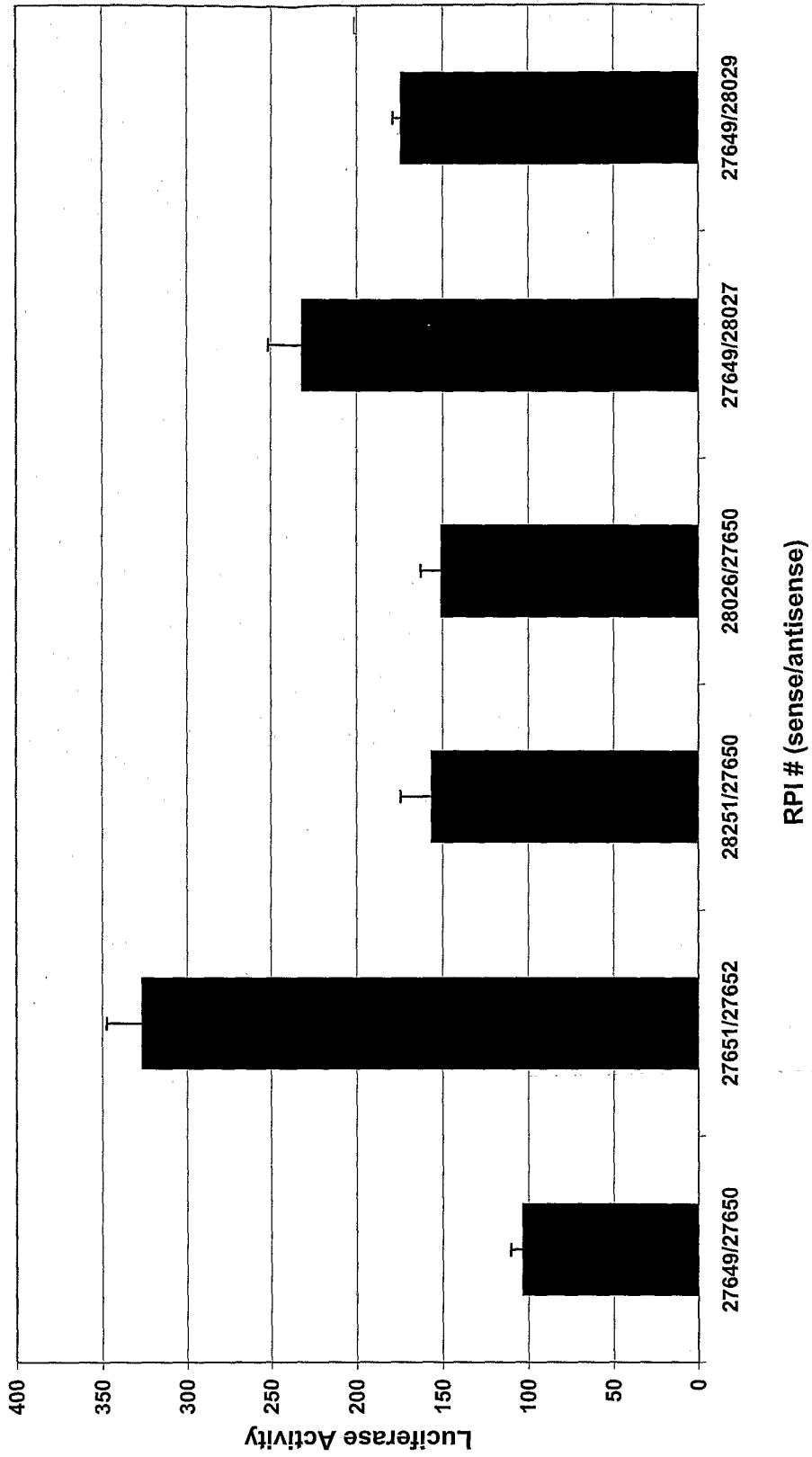


Figure 7



*Figure 8*

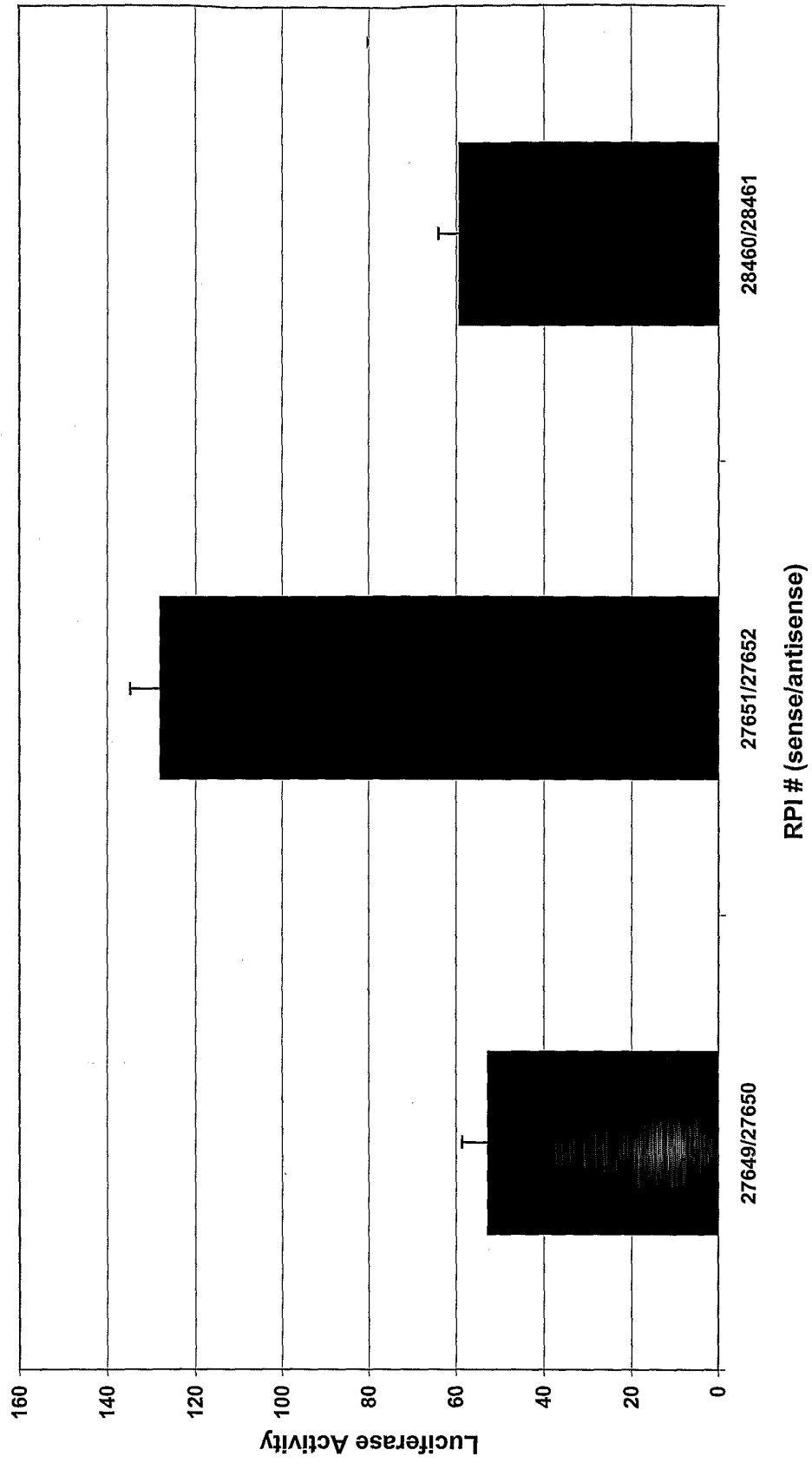


Figure 9

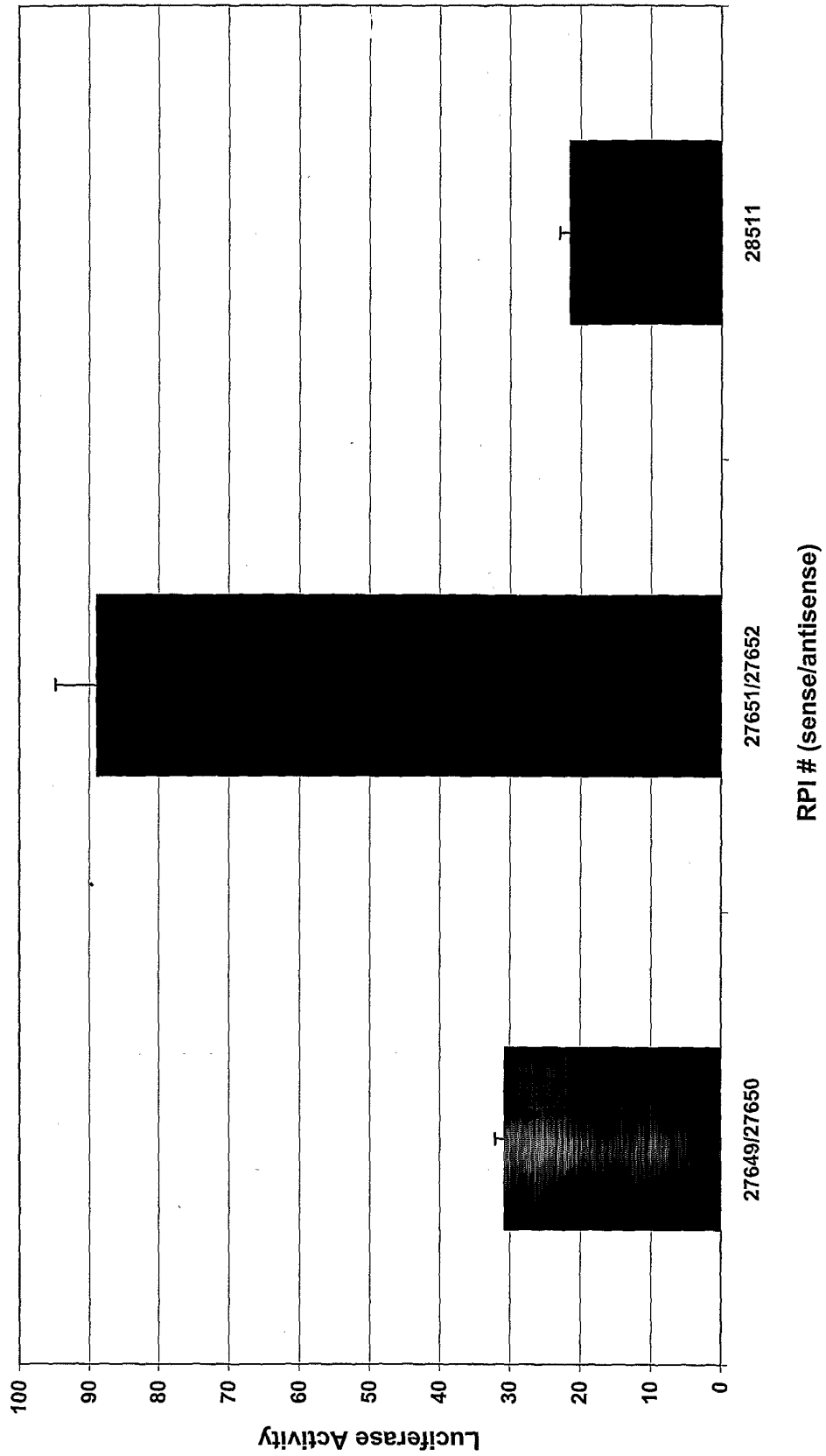


Figure 10

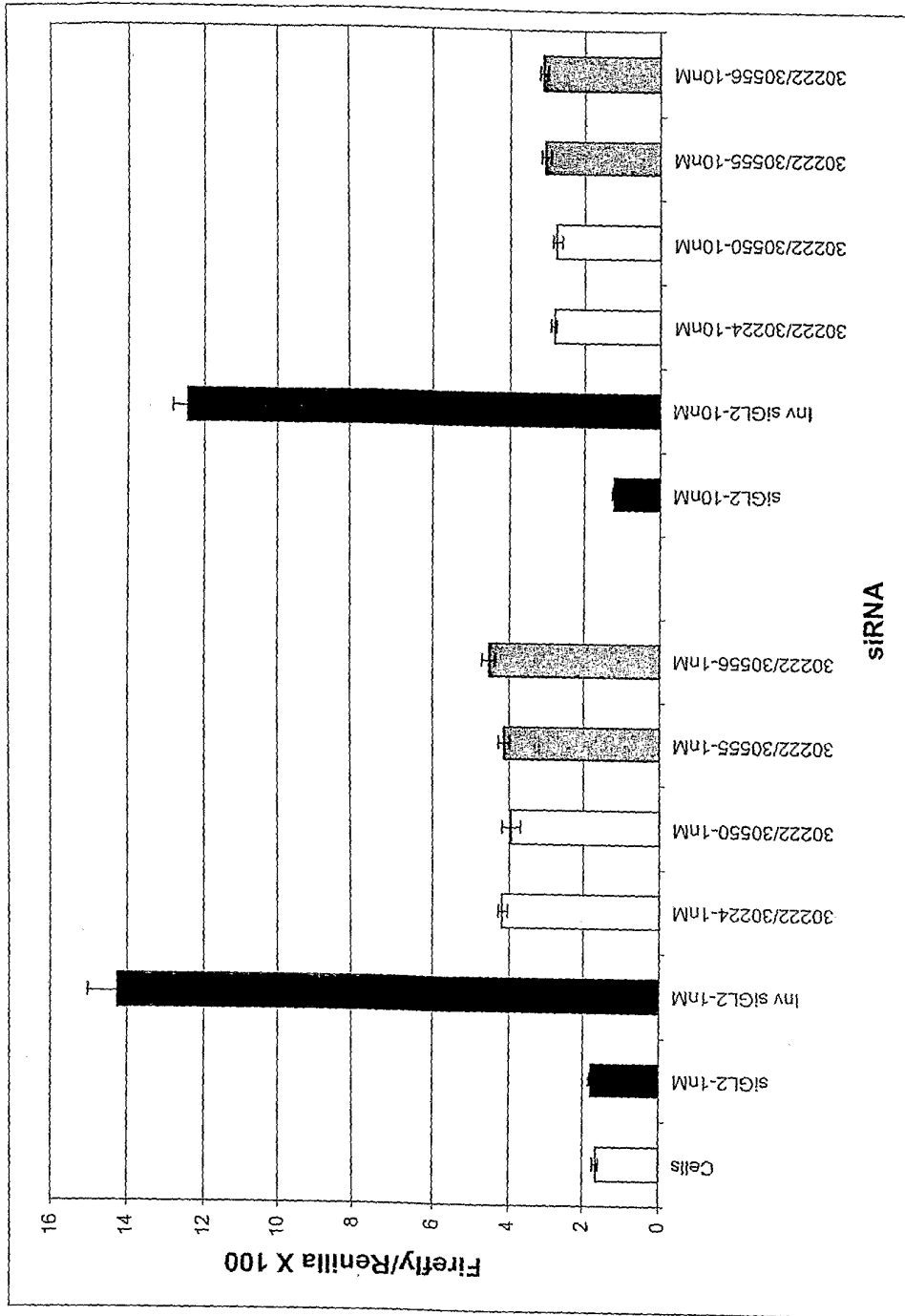


Figure 11

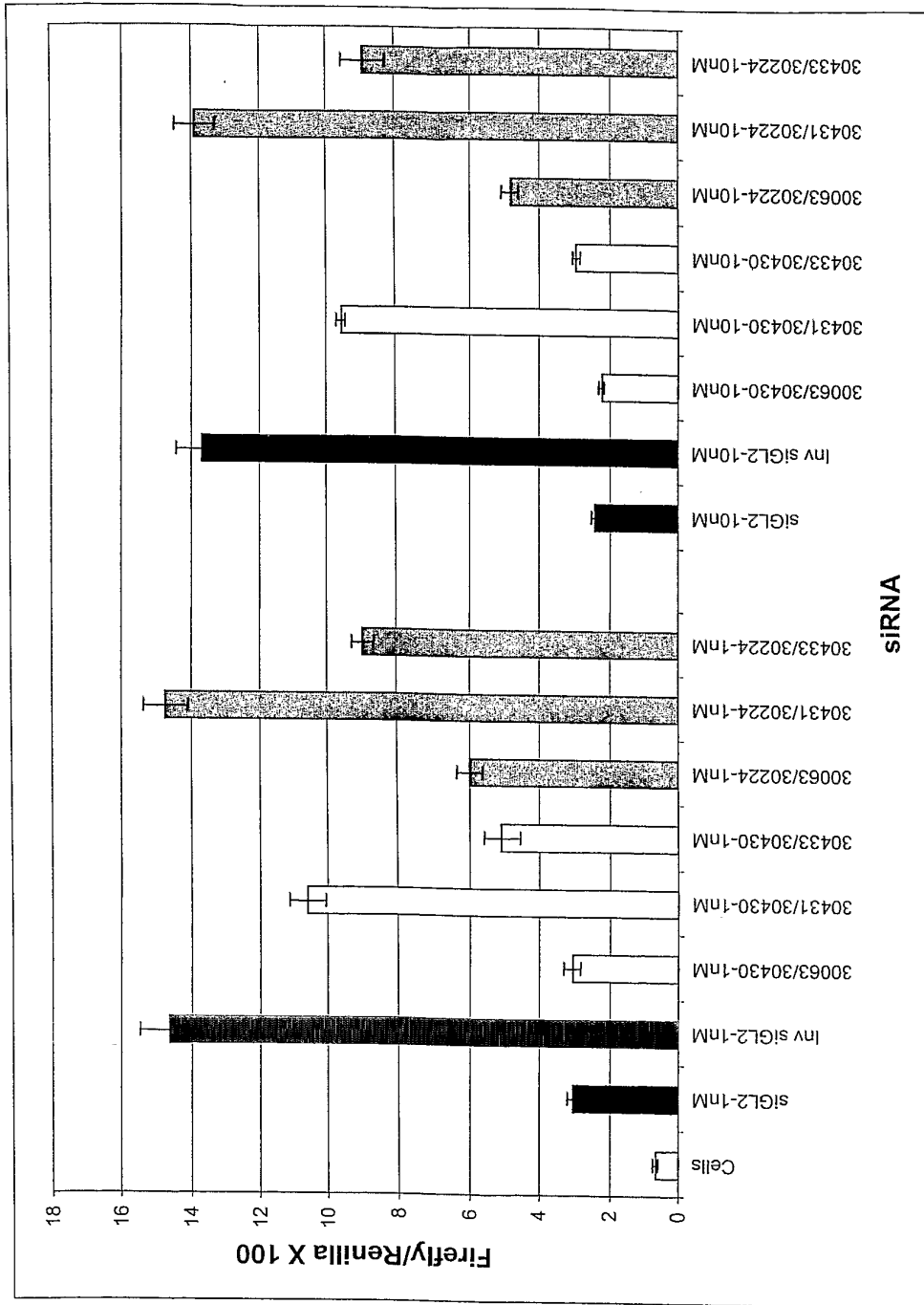


Figure 12

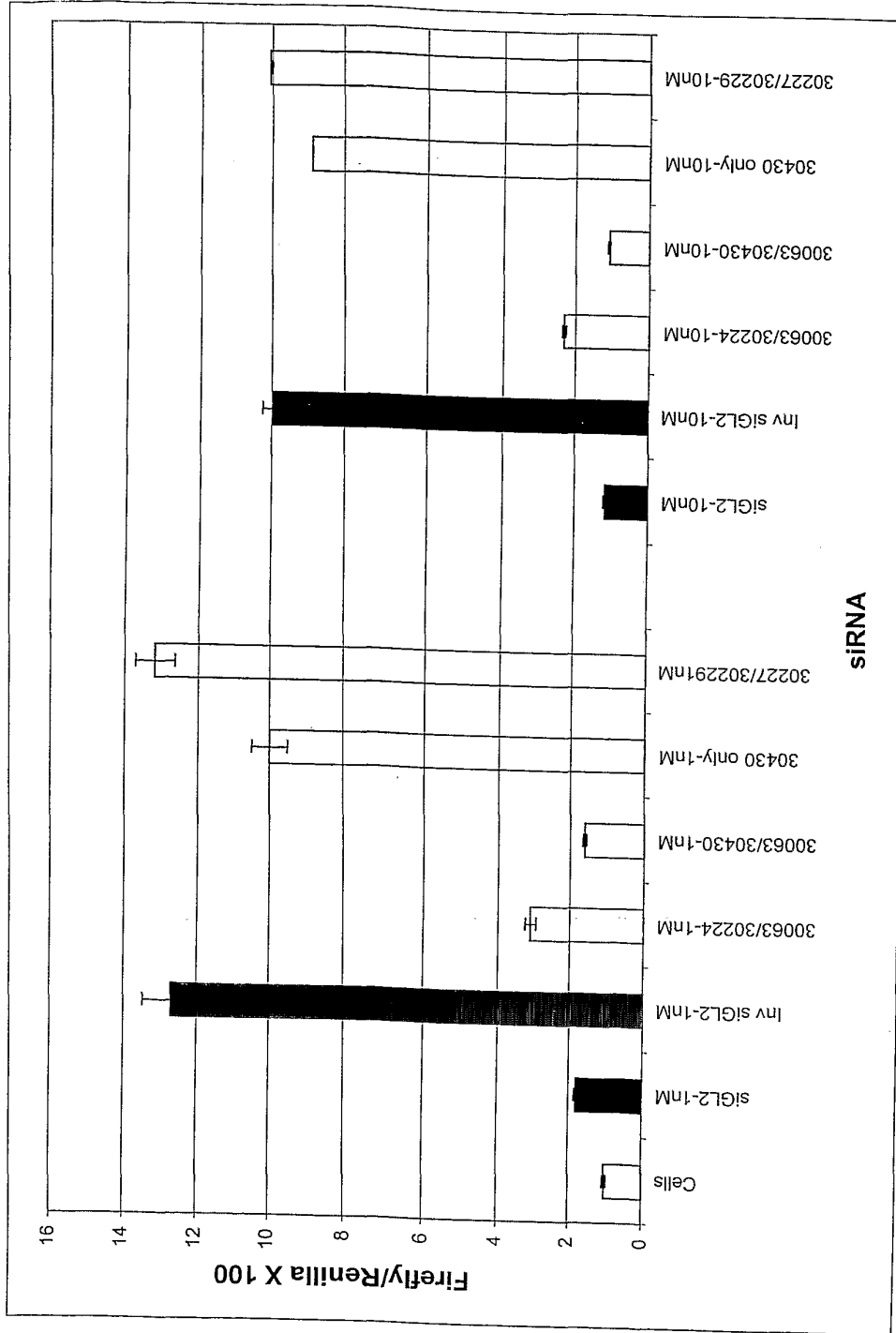




Figure 13

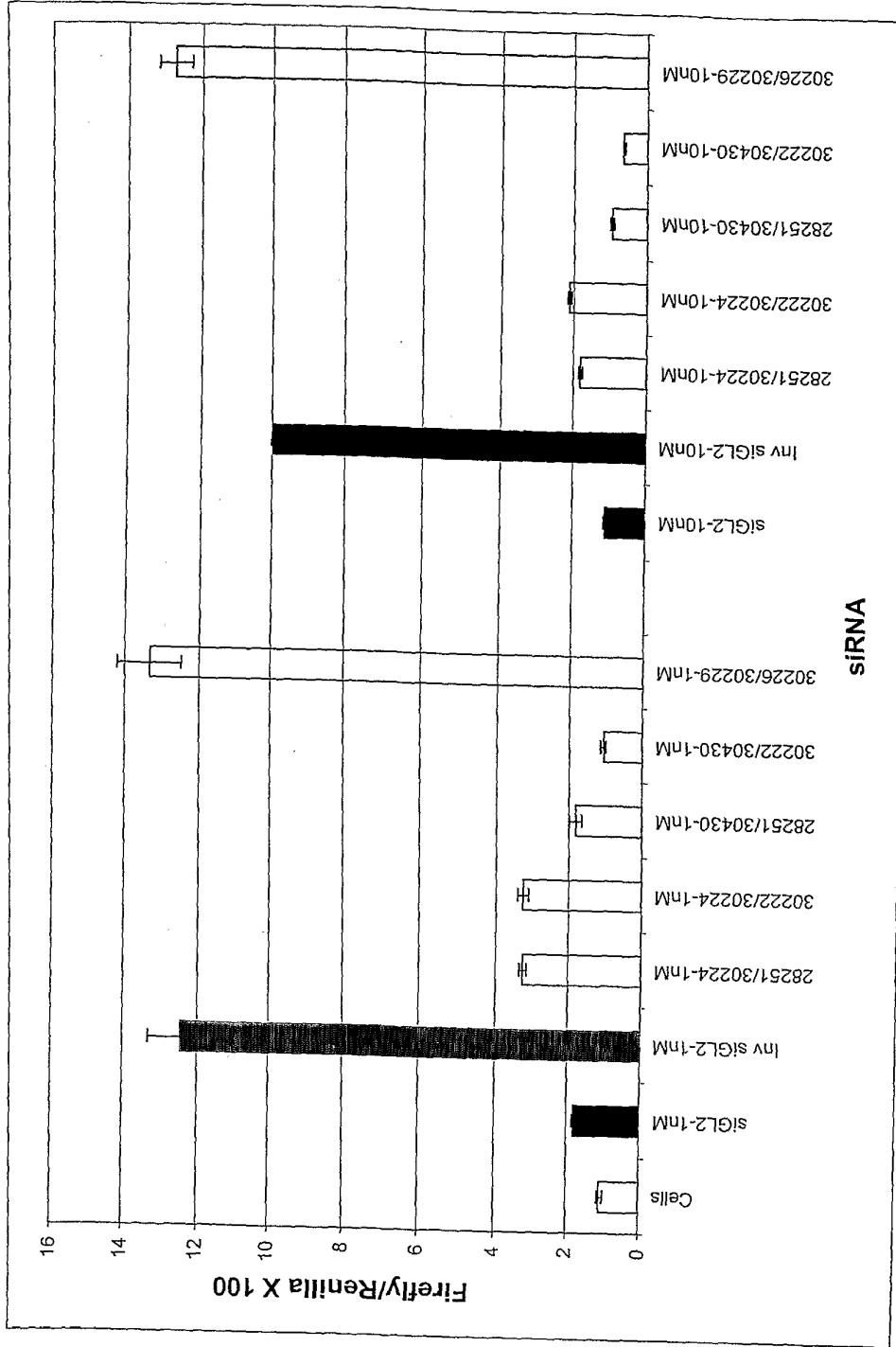


Figure 14

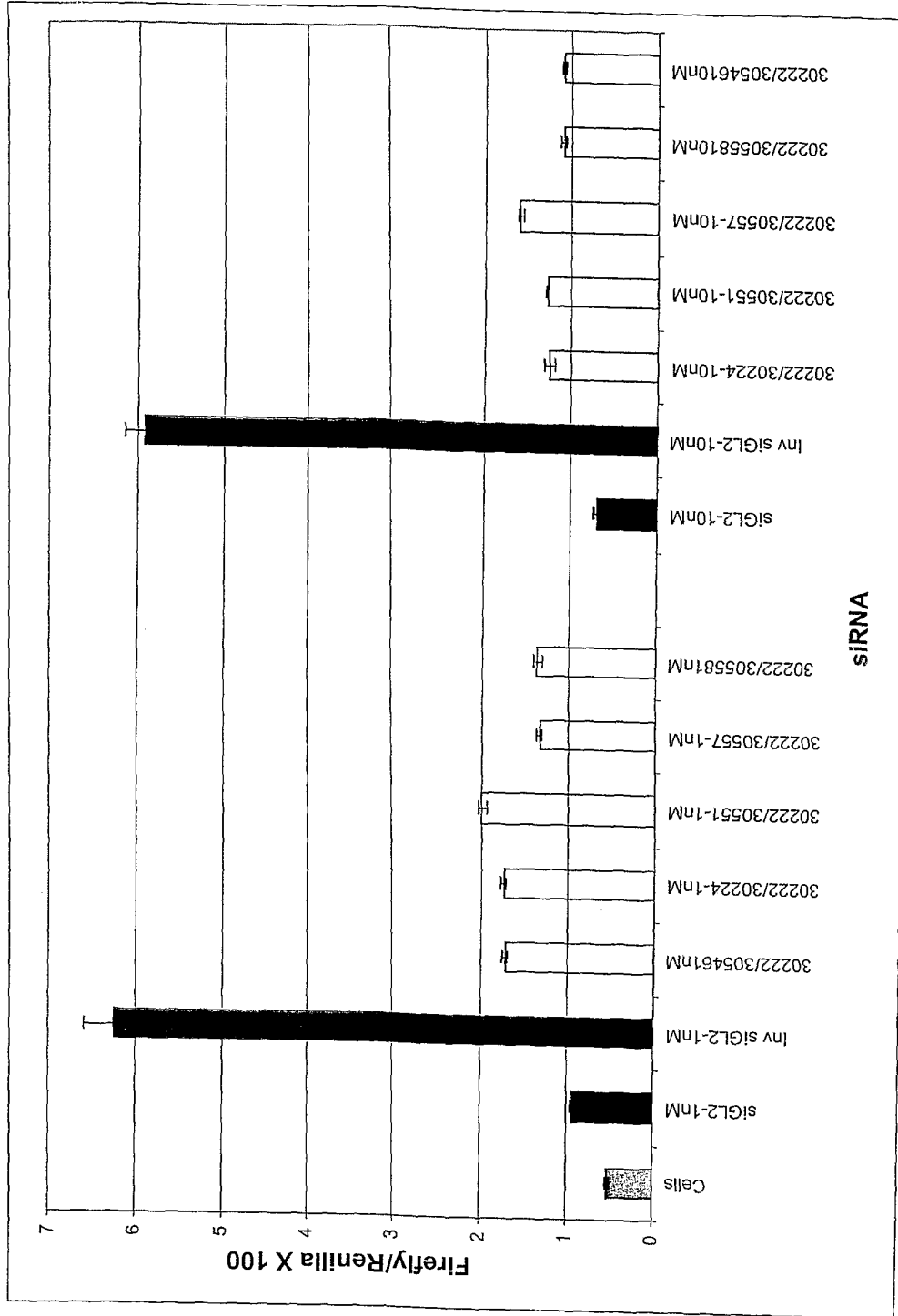


Figure 15

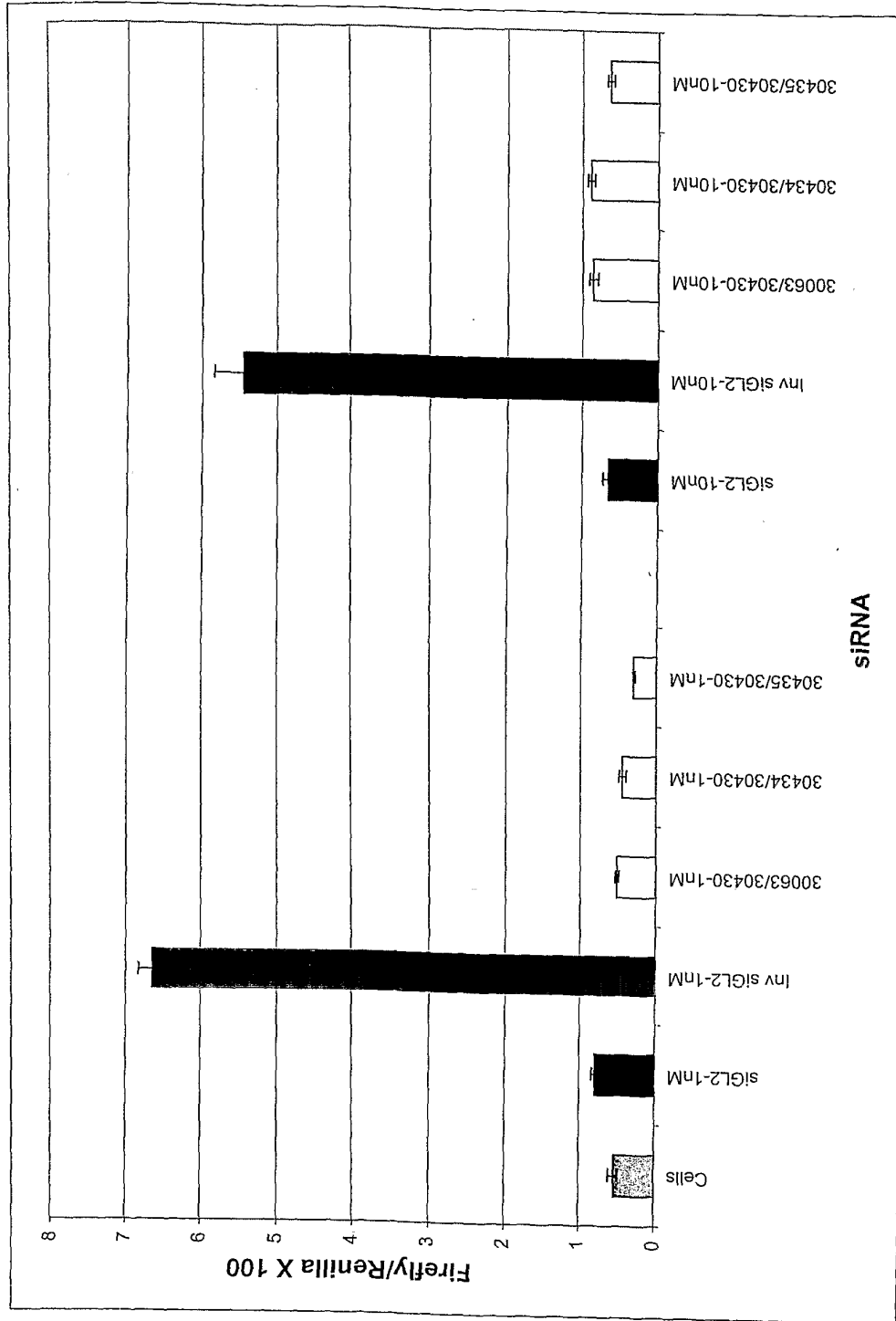
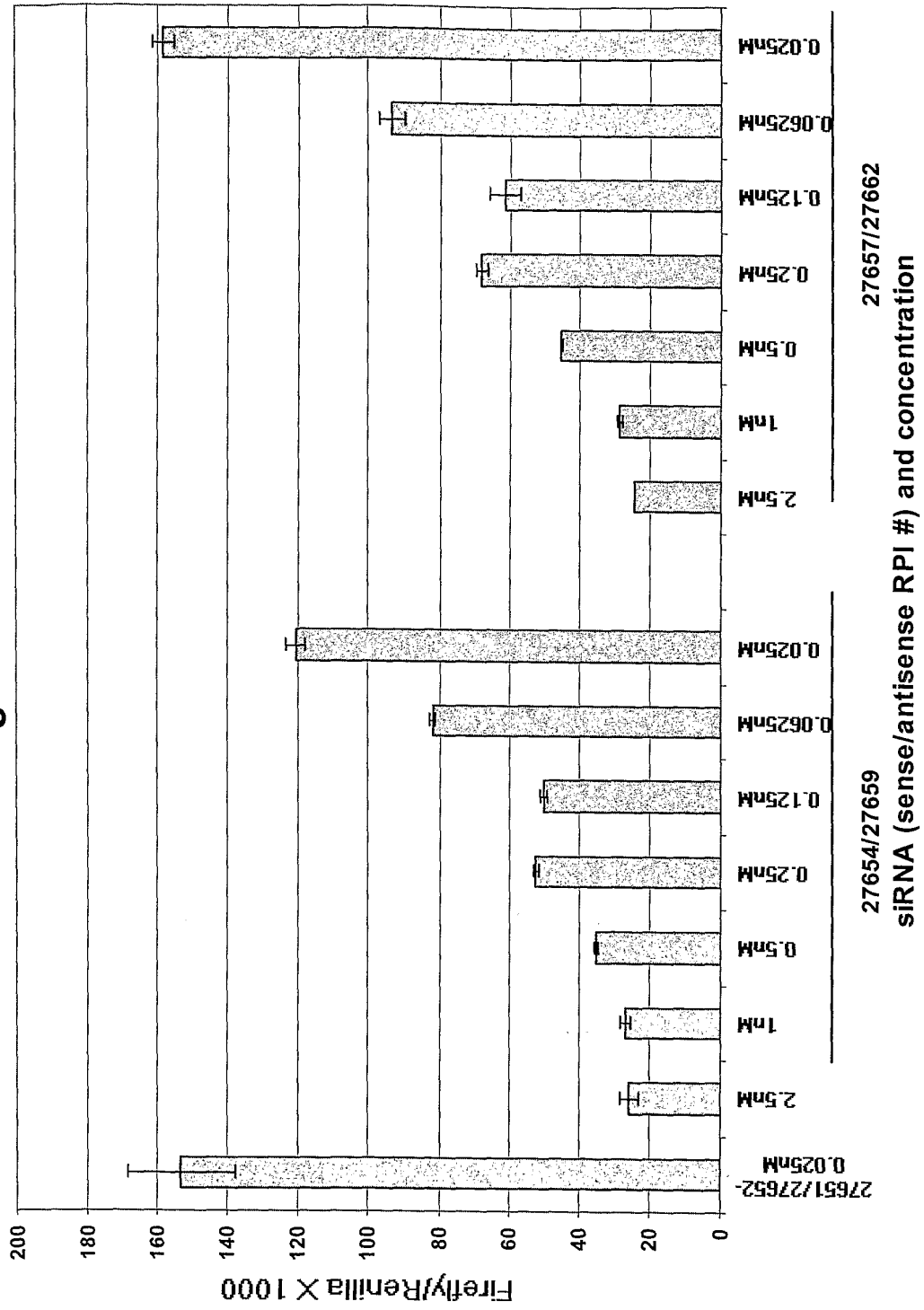
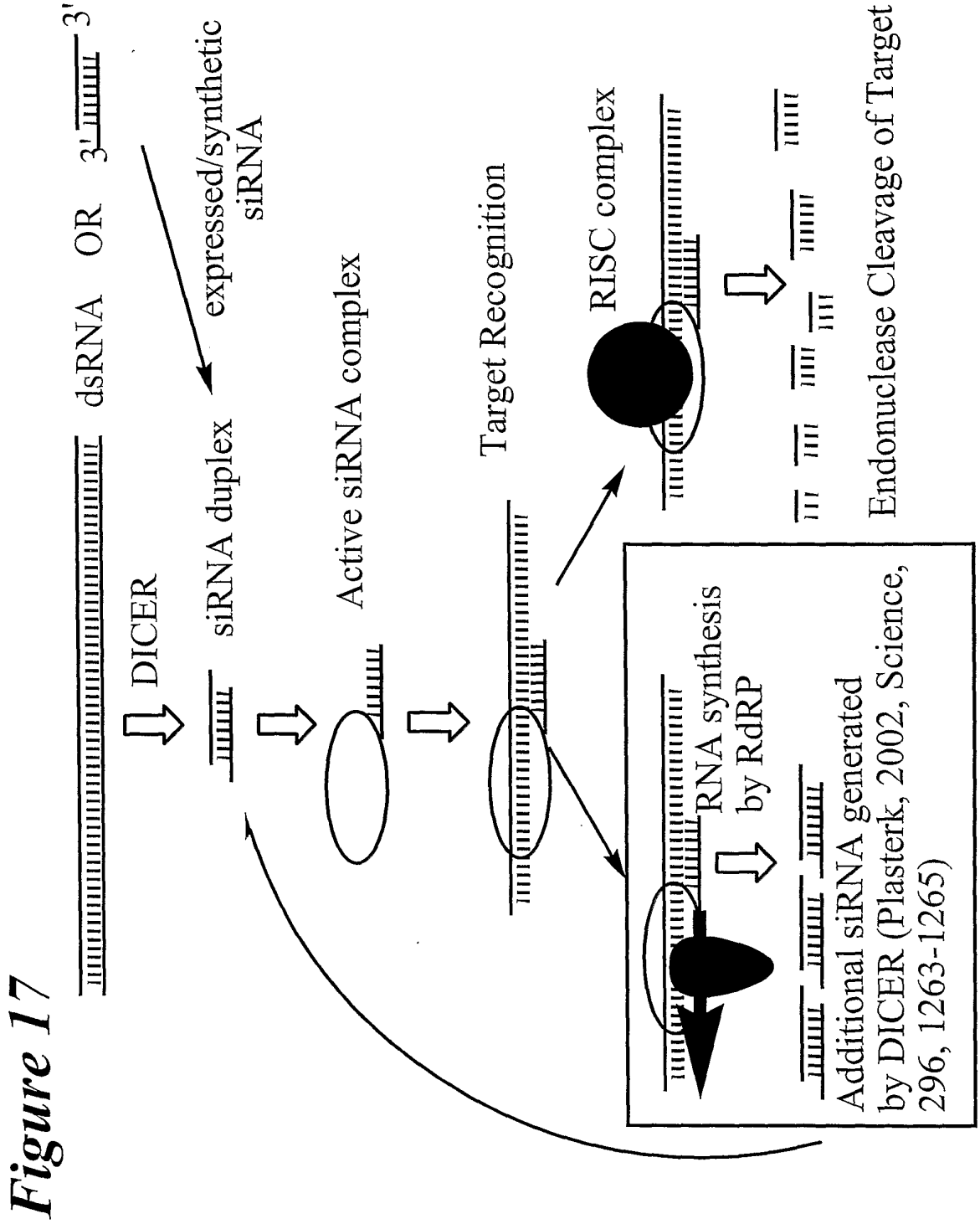
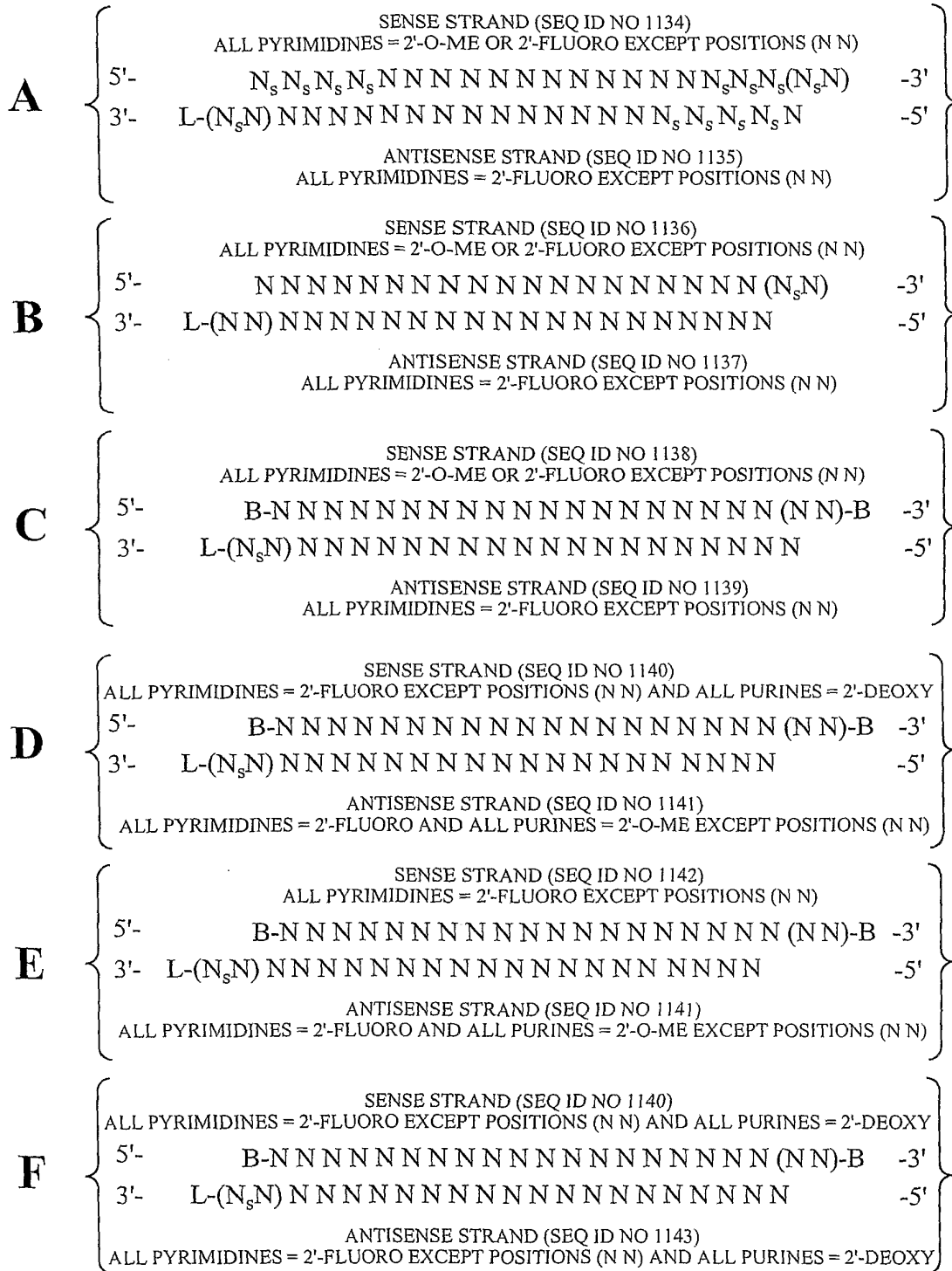


Figure 16



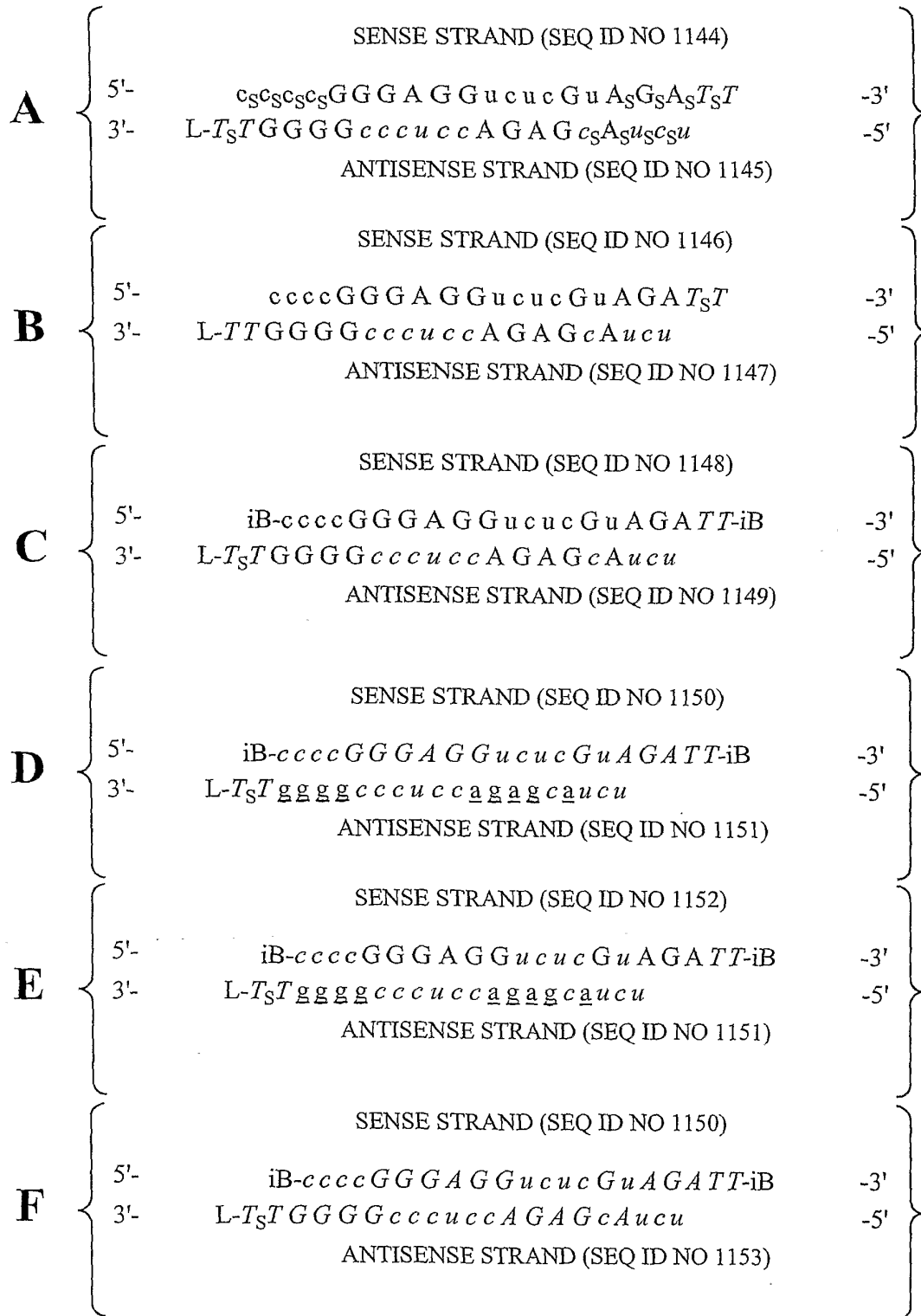


**Figure 18**



POSITIONS (NN) CAN COMPRISE ANY NUCLEOTIDE, SUCH AS DEOXYNUCLEOTIDES (eg. THYMIDINE) OR UNIVERSAL BASES  
 B = ABASIC, INVERTED ABASIC, INVERTED NUCLEOTIDE OR OTHER TERMINAL CAP THAT IS OPTIONALLY PRESENT  
 L = GLYCERYL or B THAT IS OPTIONALLY PRESENT  
 S = PHOSPHOROTHIOATE OR PHOSPHORODITHIOATE that is optionally absent

**Figure 19**



lower case = 2'-O-Methyl or 2'-deoxy-2'-fluoro

*italic lower case* = 2'-deoxy-2'-fluoro

underline = 2'-O-methyl

*ITALIC UPPER CASE* = DEOXY

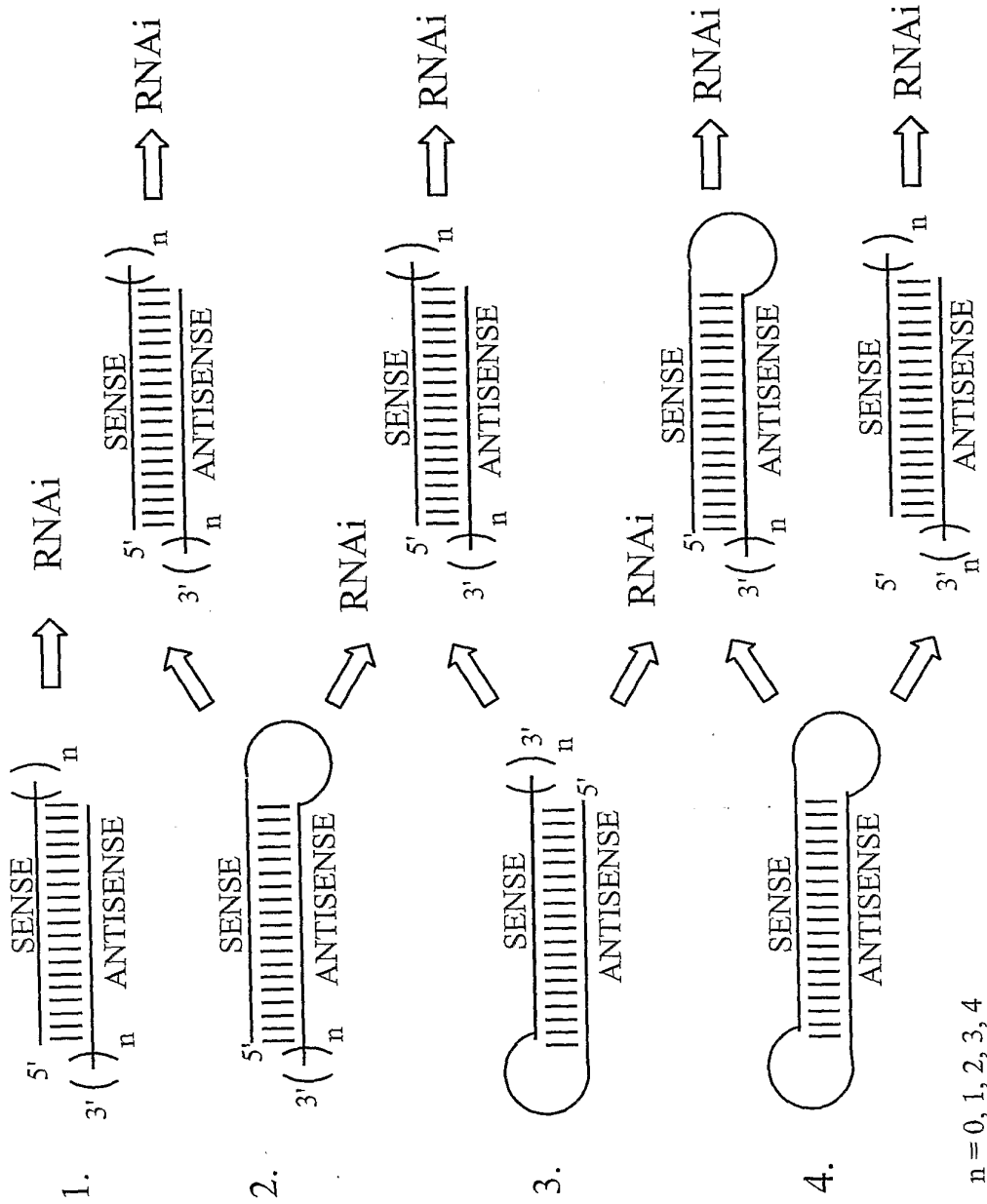
iB = INVERTED DEOXYABASIC

L = GLYCERYL MOIETY or iB OPTIONALLY PRESENT

S = PHOSPHOROTHIOATE OR

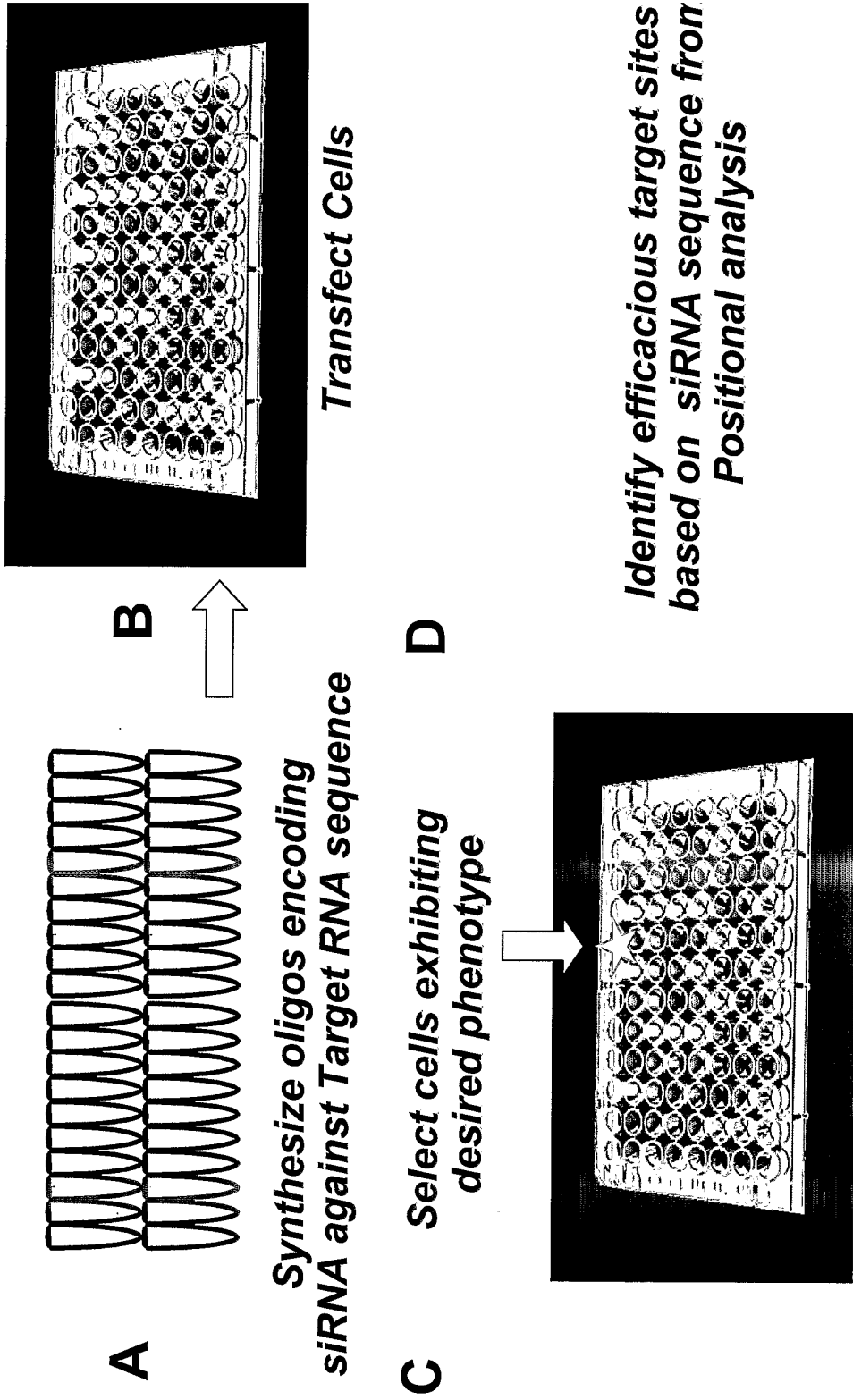
PHOSPHORODITHIOATE OPTIONALLY PRESENT

**Figure 20**

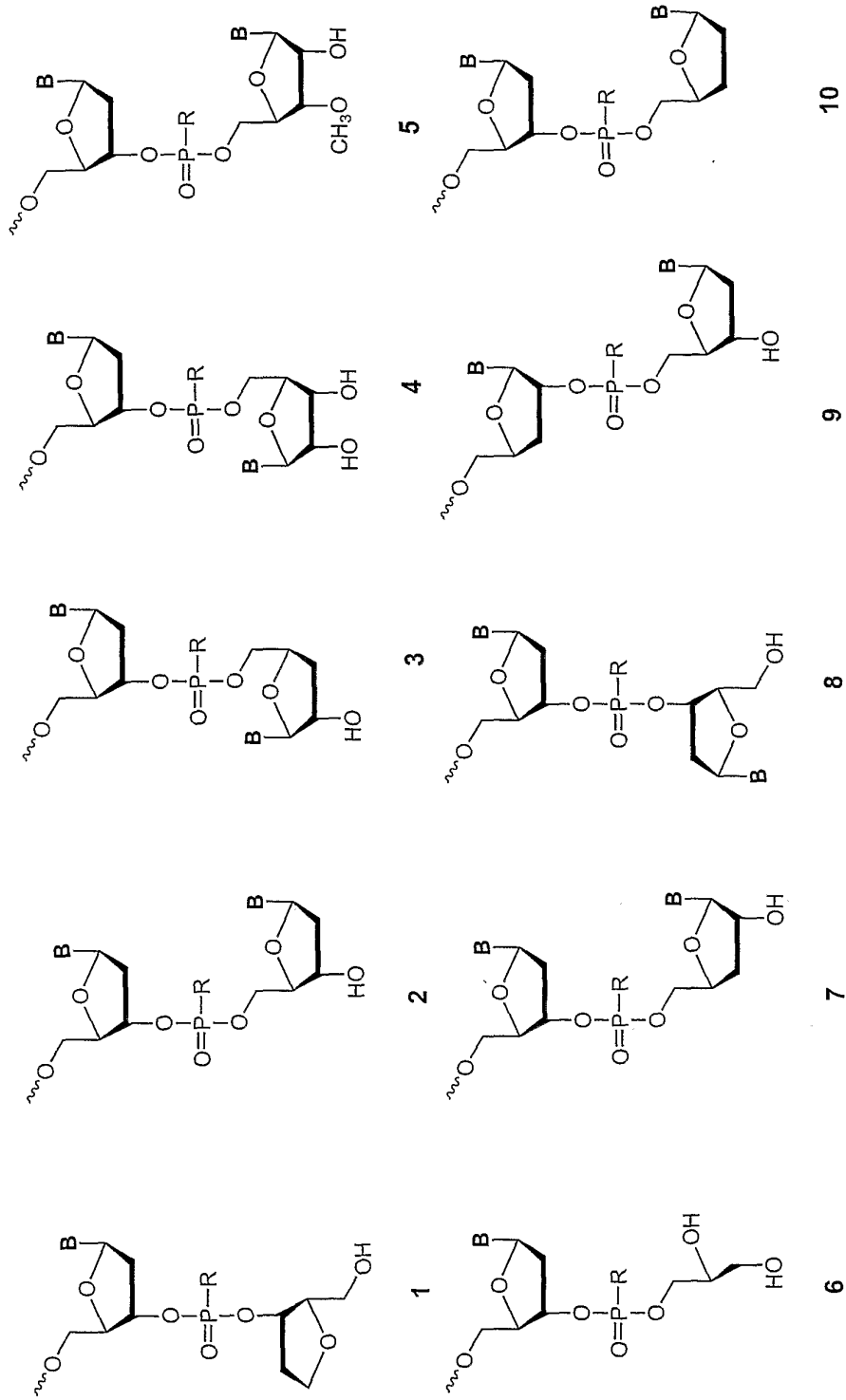




**Figure 21: Target site Selection using siRNA**

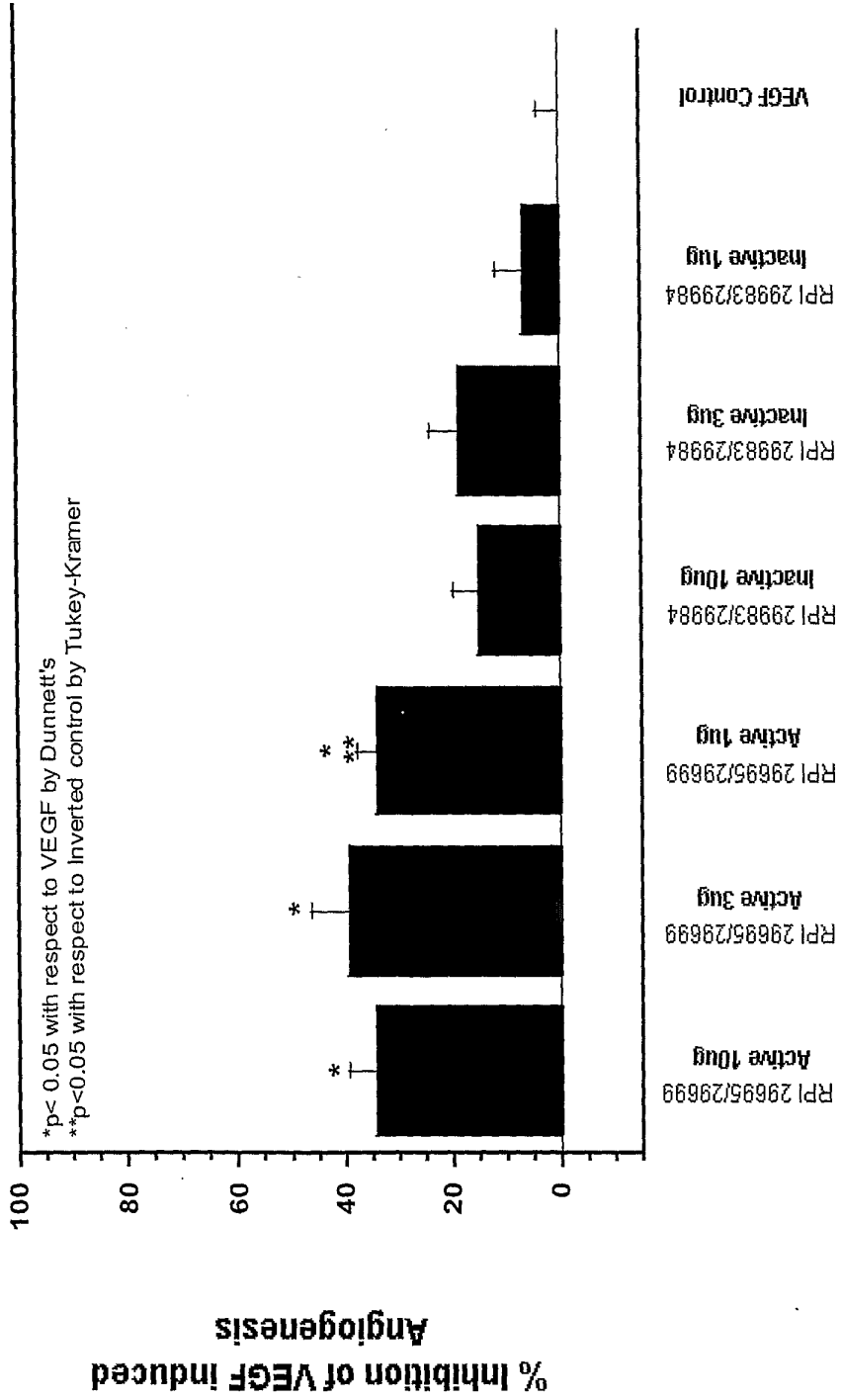


**Figure 22**

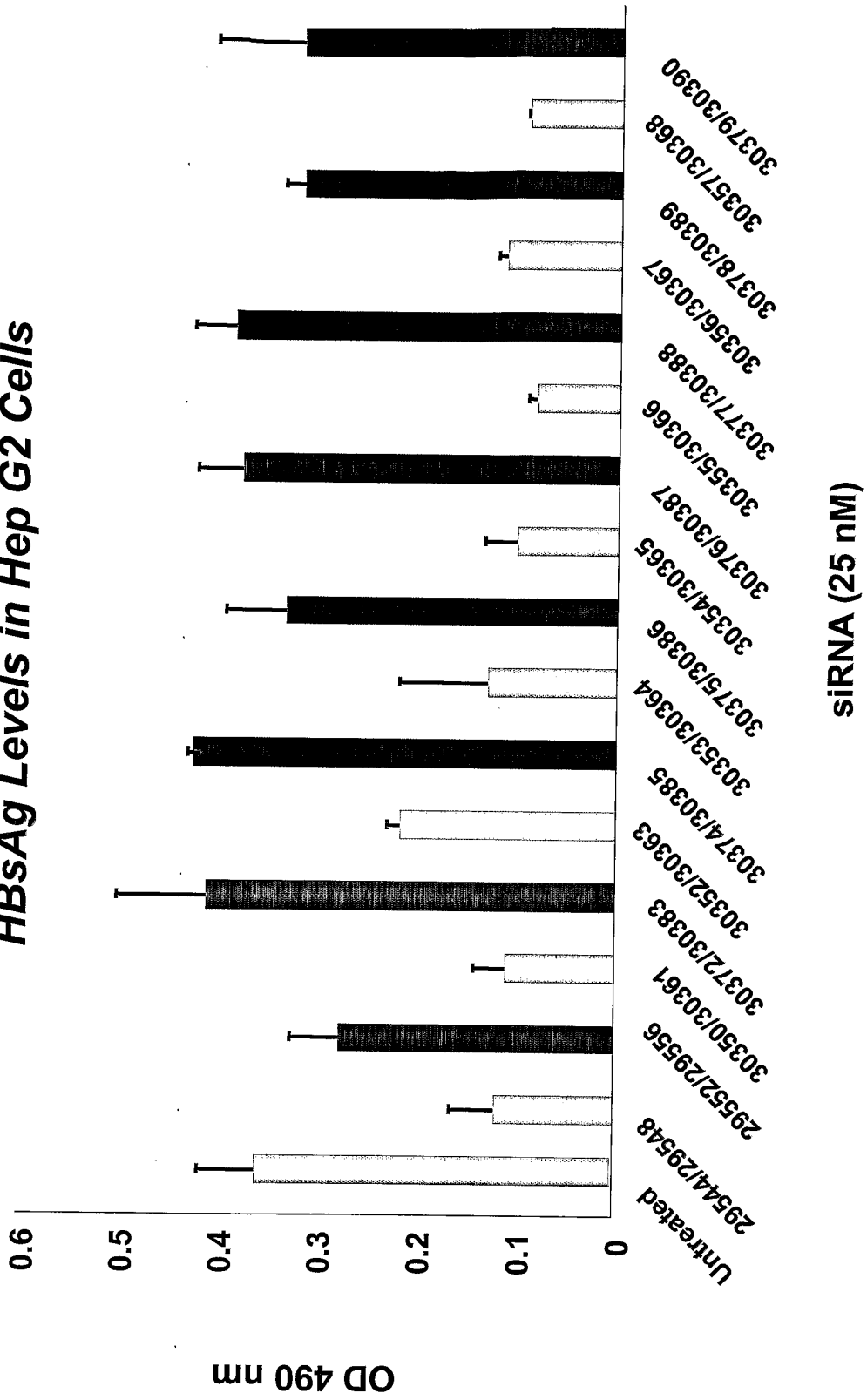


R = O, S, N, alkyl, substituted alkyl, O-alkyl, S-alkyl, alkaryl, or aralkyl  
 B = Independently any nucleotide base, either naturally occurring or chemically modified, or optionally H (abasic).

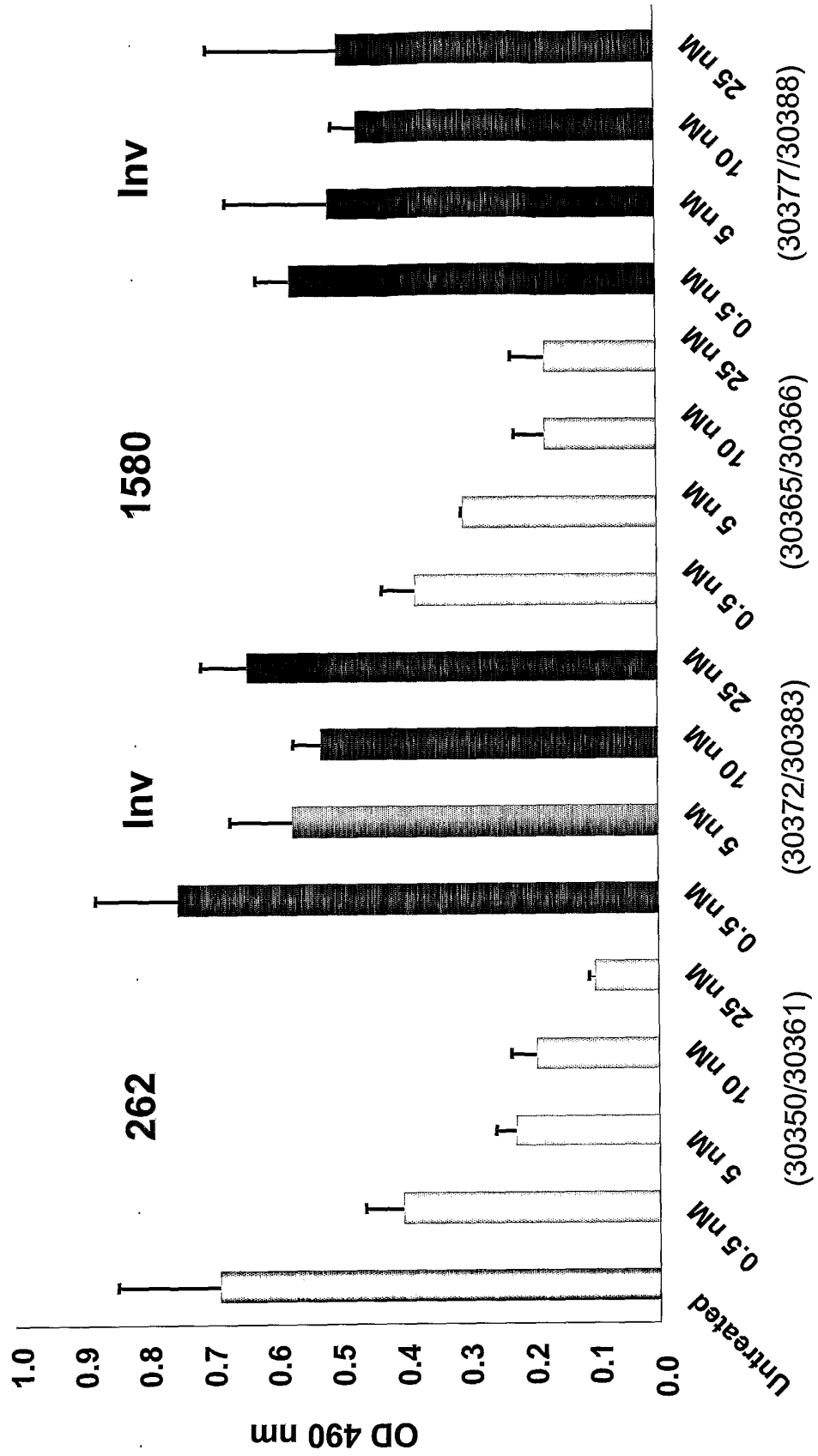
**Figure 23: Inhibition of VEGF-Induced Angiogenesis by siRNAs**



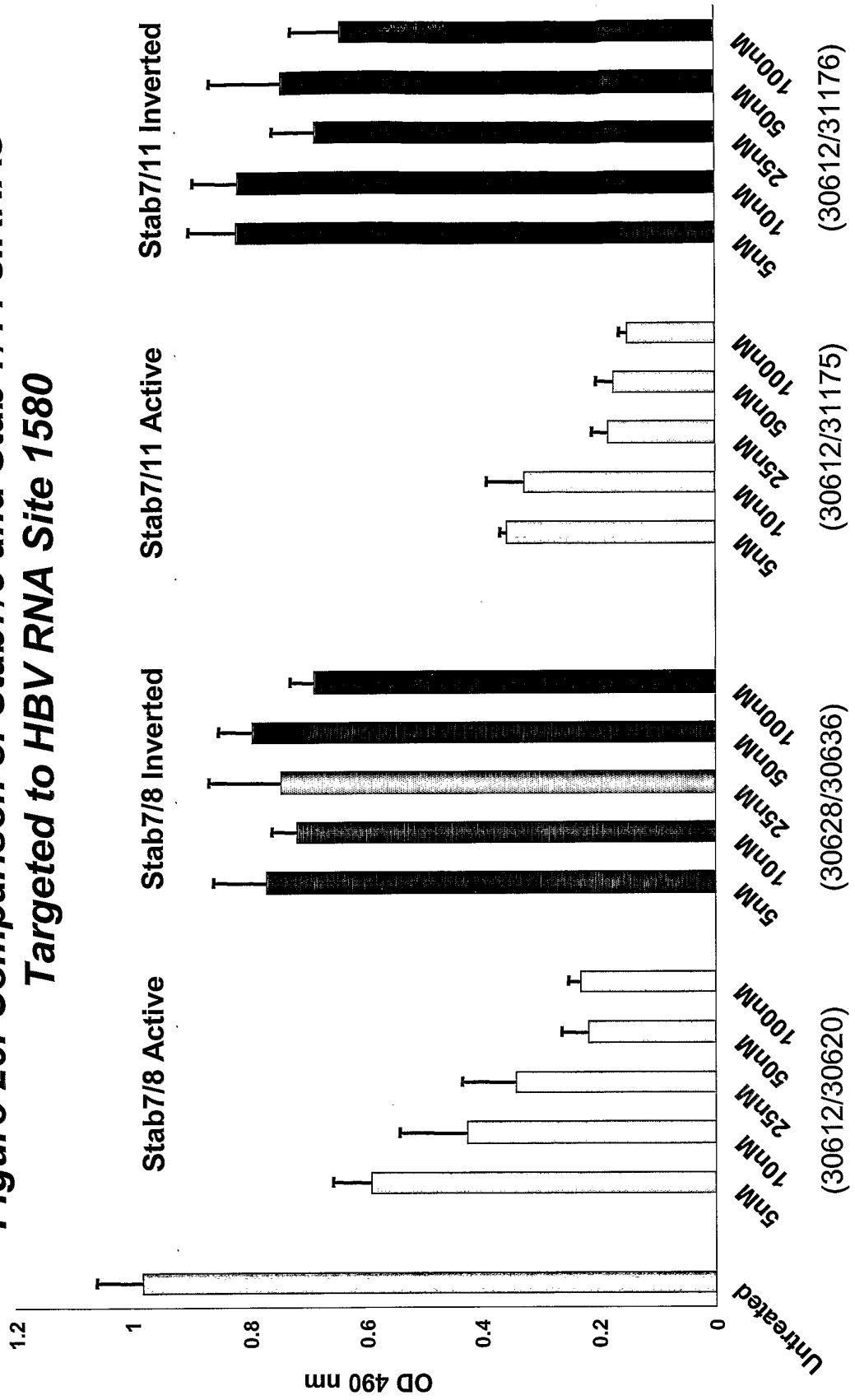
**Figure 24: Stab4/5 siNA Targeted to HBV:  
HBsAg Levels in Hep G2 Cells**



**Figure 25: Dose Response with Stab4/5 siRNAs Targeted to HBV Sites 262 & 1580**



**Figure 26: Comparison of Stab7/8 and Stab 7/11 siRNAs Targeted to HBV RNA Site 1580**



*Figure 27: Modification Strategy*

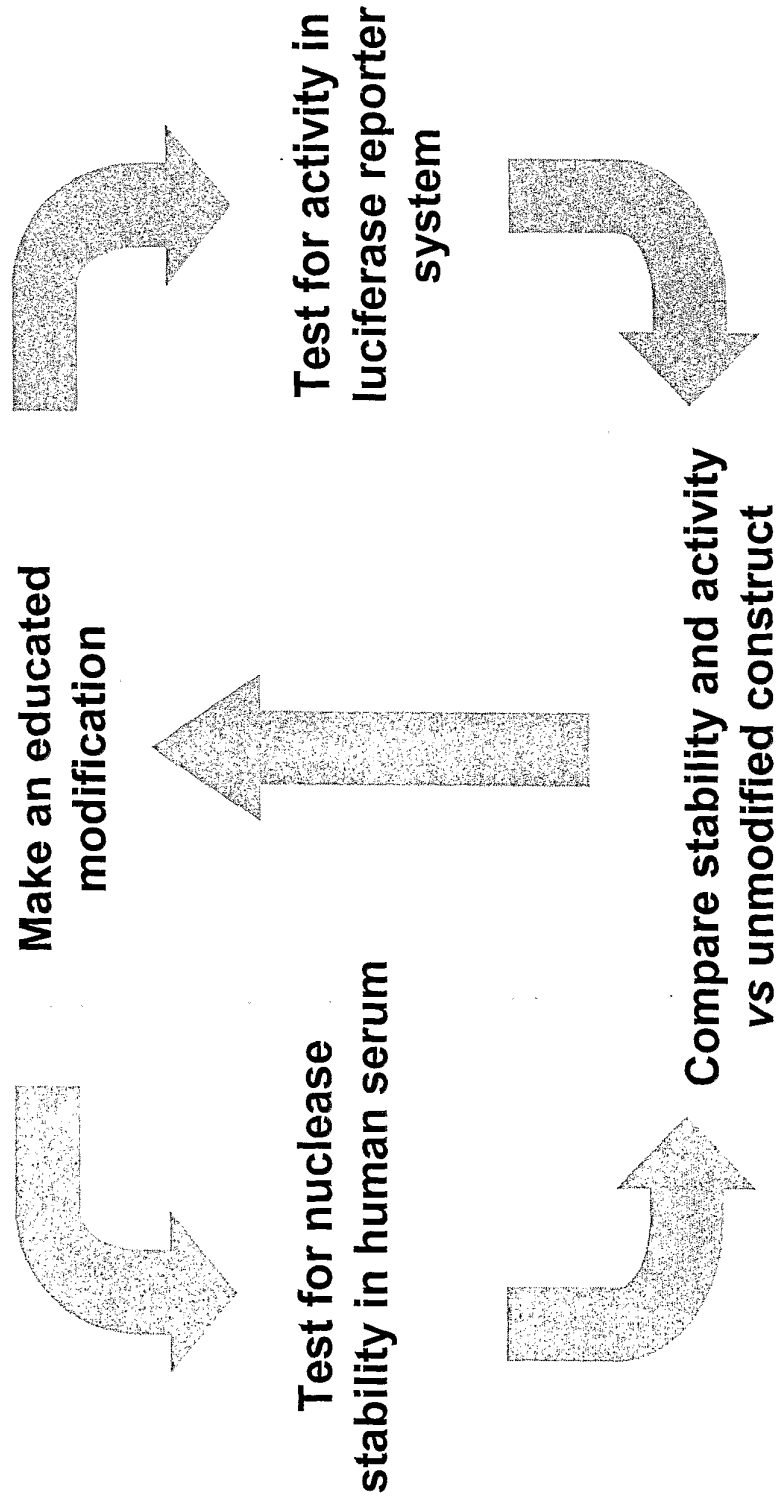


Figure 28: Duration of siRNA Effect  
All-Ribo vs. Stab4/5 HBV Site 1580: HBsAg Levels

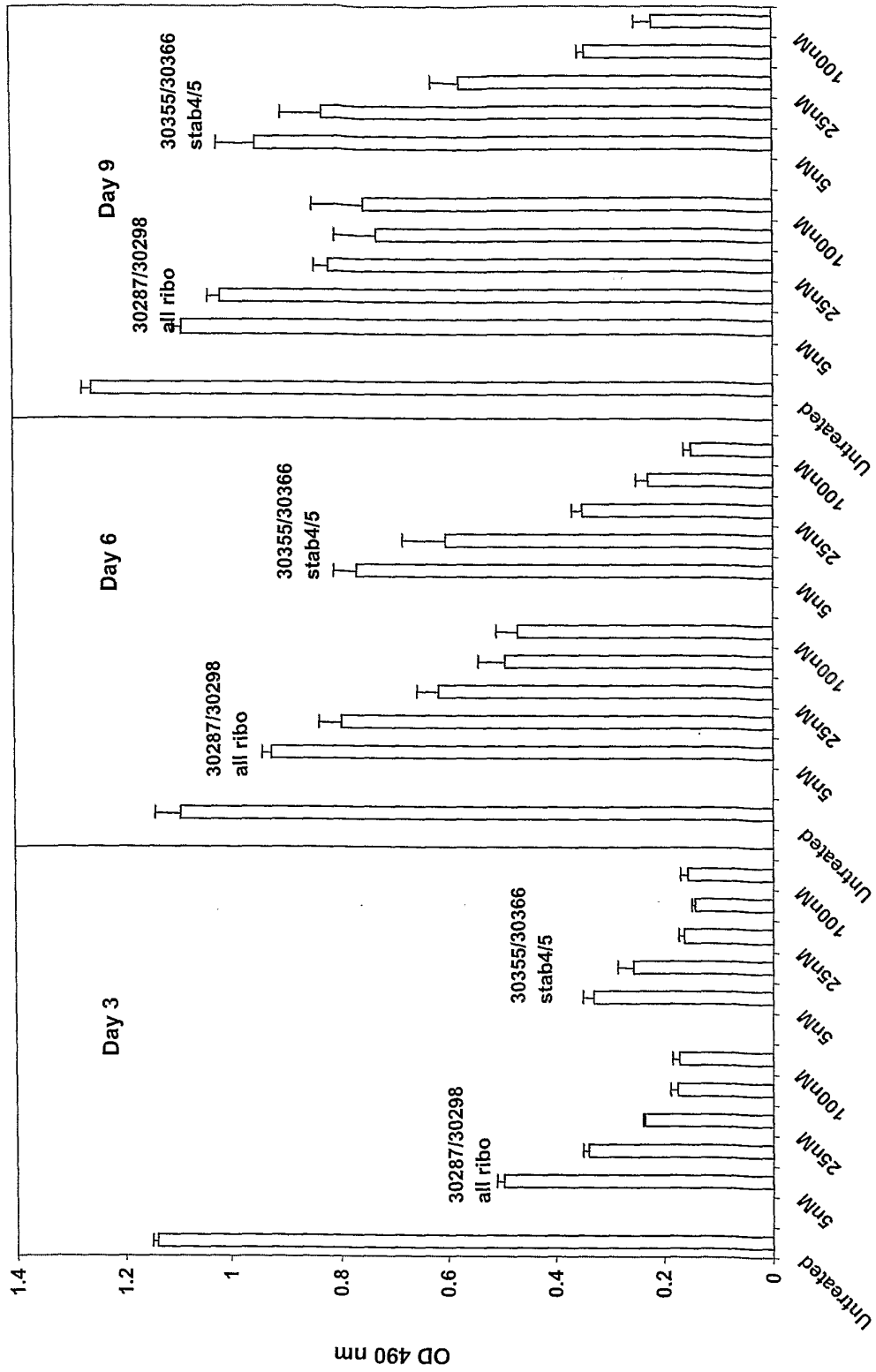




Figure 29: Duration of siRNA Effect  
All-Ribo vs. Stab7/8 HBV Site 1580: HBsAg Levels

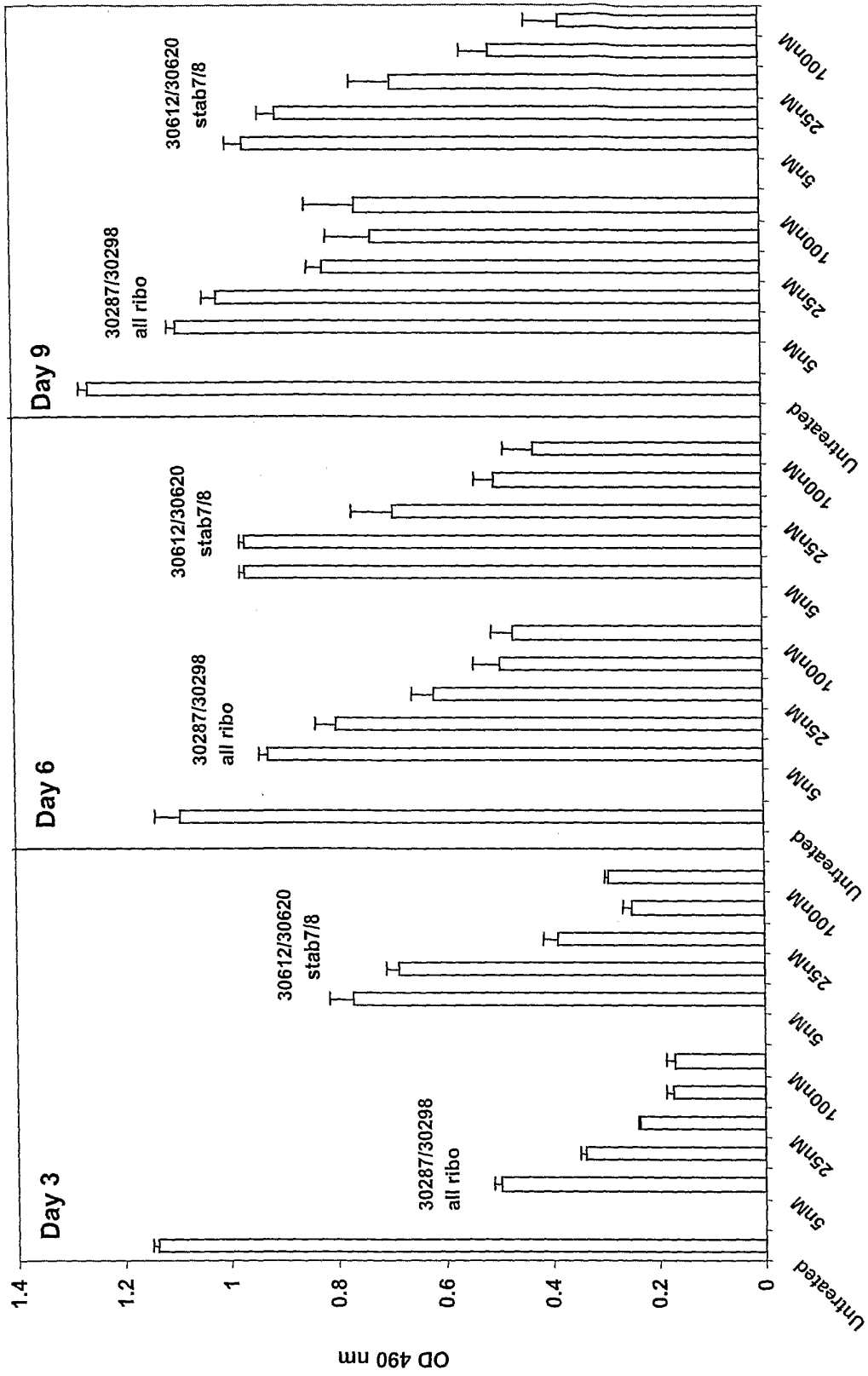


Figure 30: Duration of siRNA Effect  
All-Ribo vs. Stab7/11 HBV Site 1580: HBsAg Levels

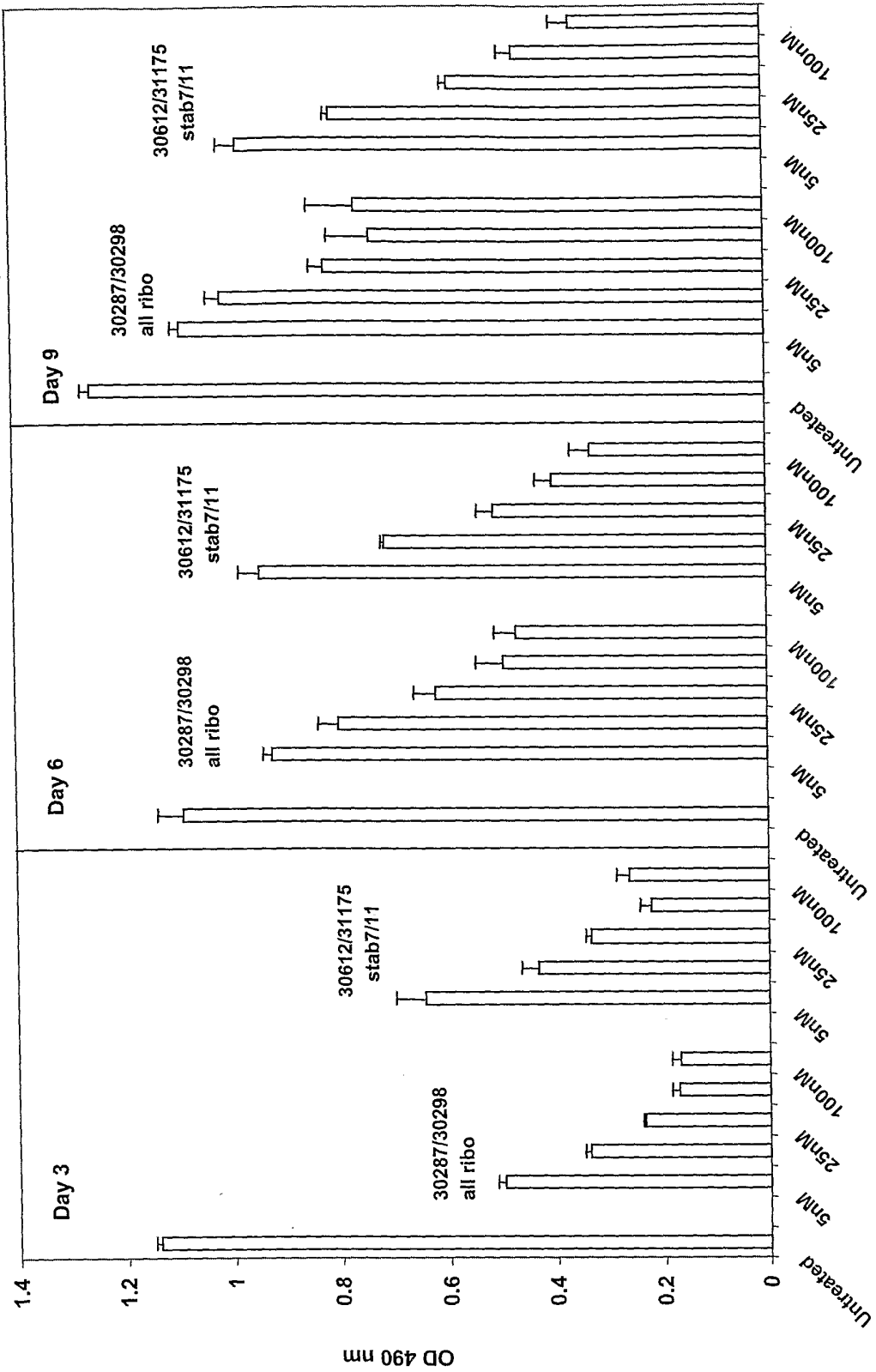
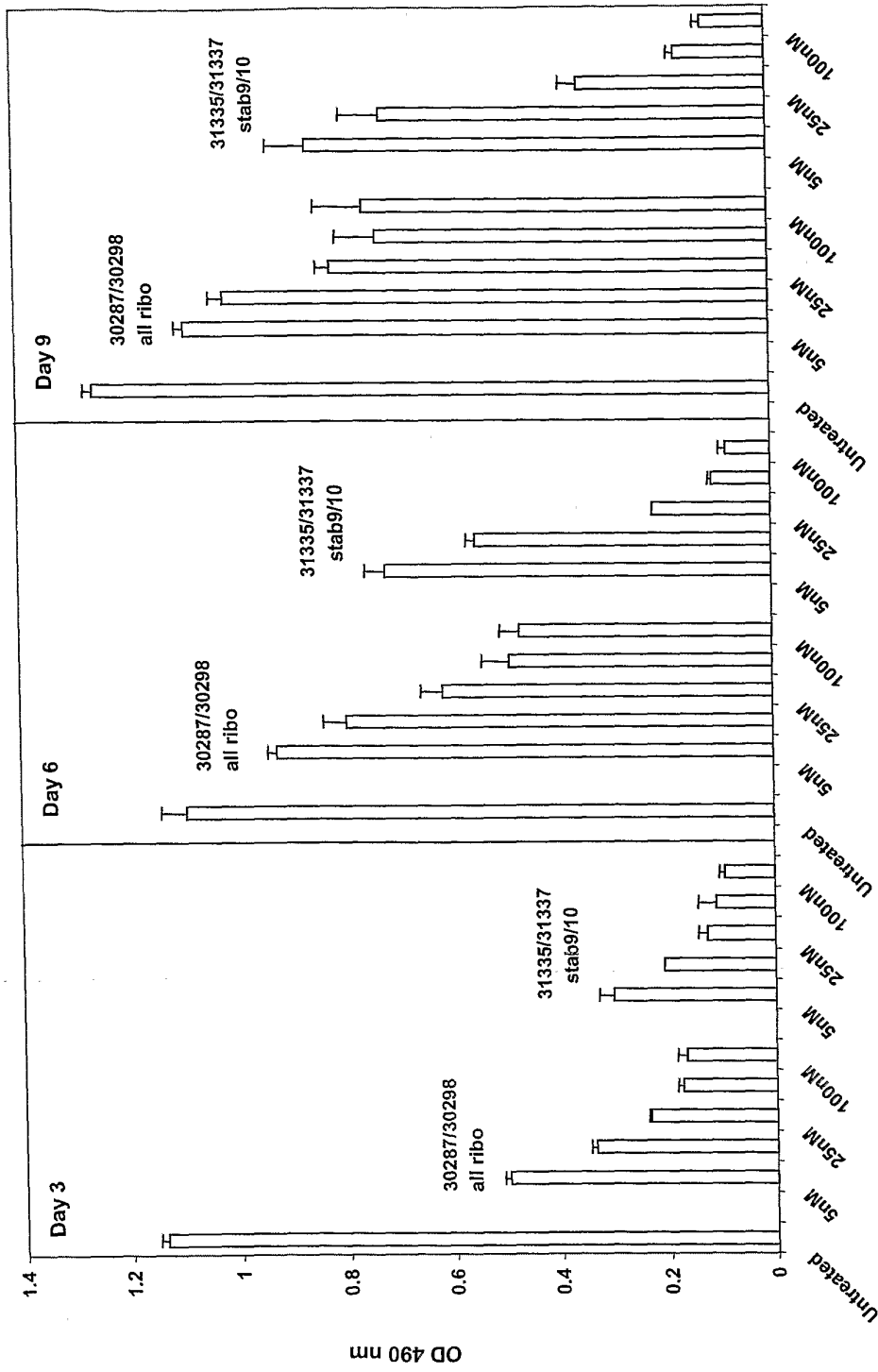
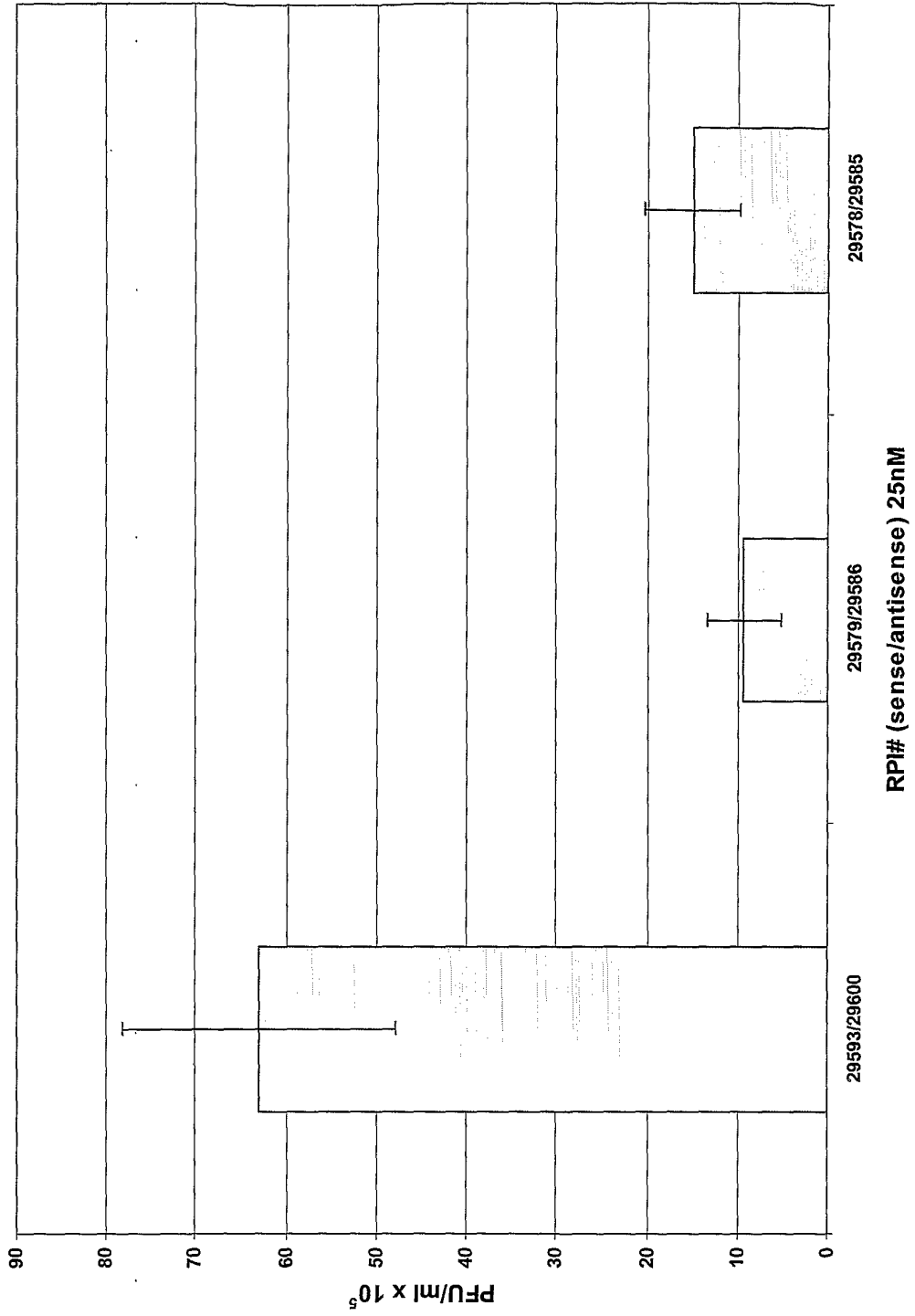


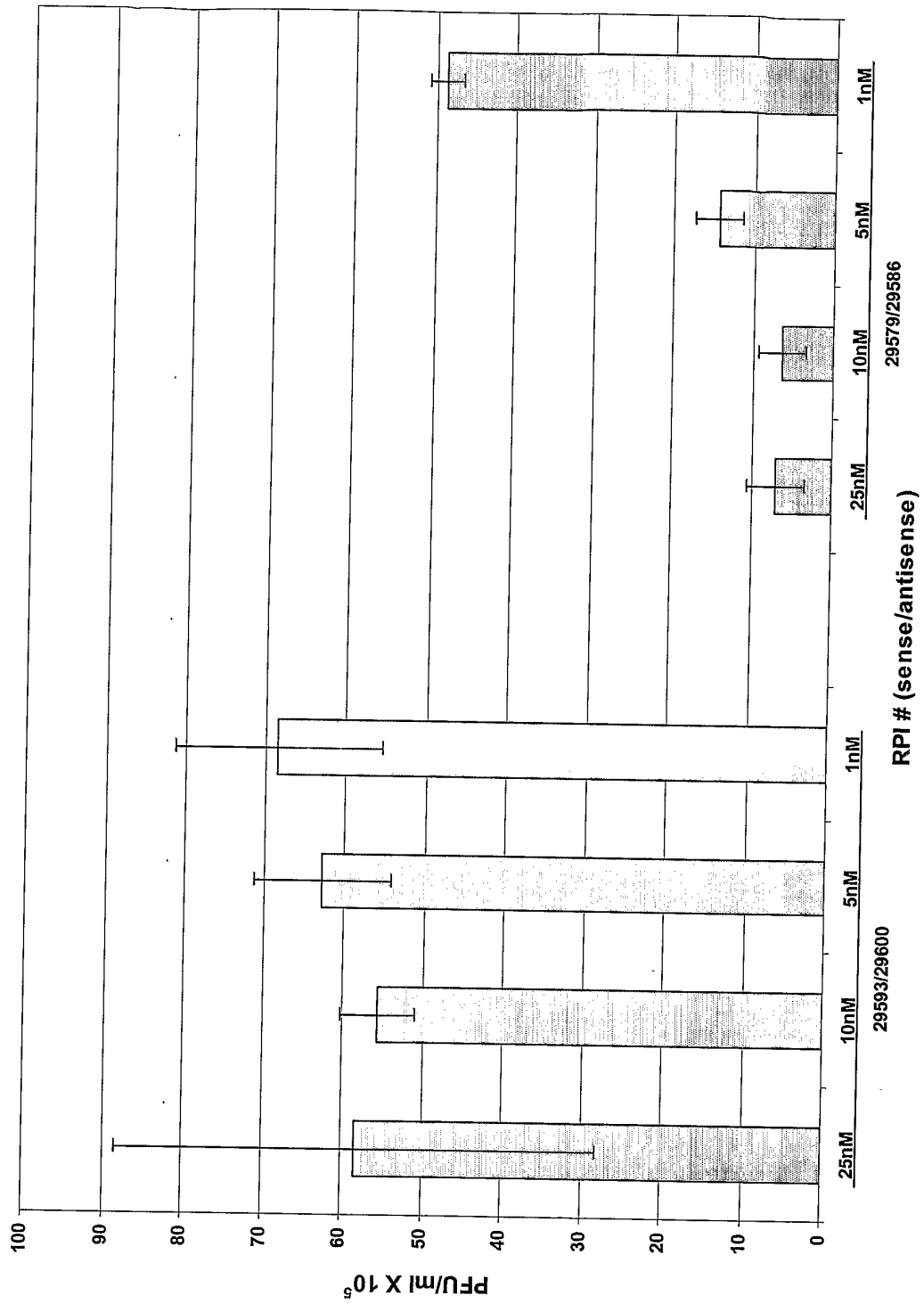
Figure 31: Duration of siRNA Effect  
All-Ribo vs. Stab9/10 HBV Site 1580: HBsAg Levels



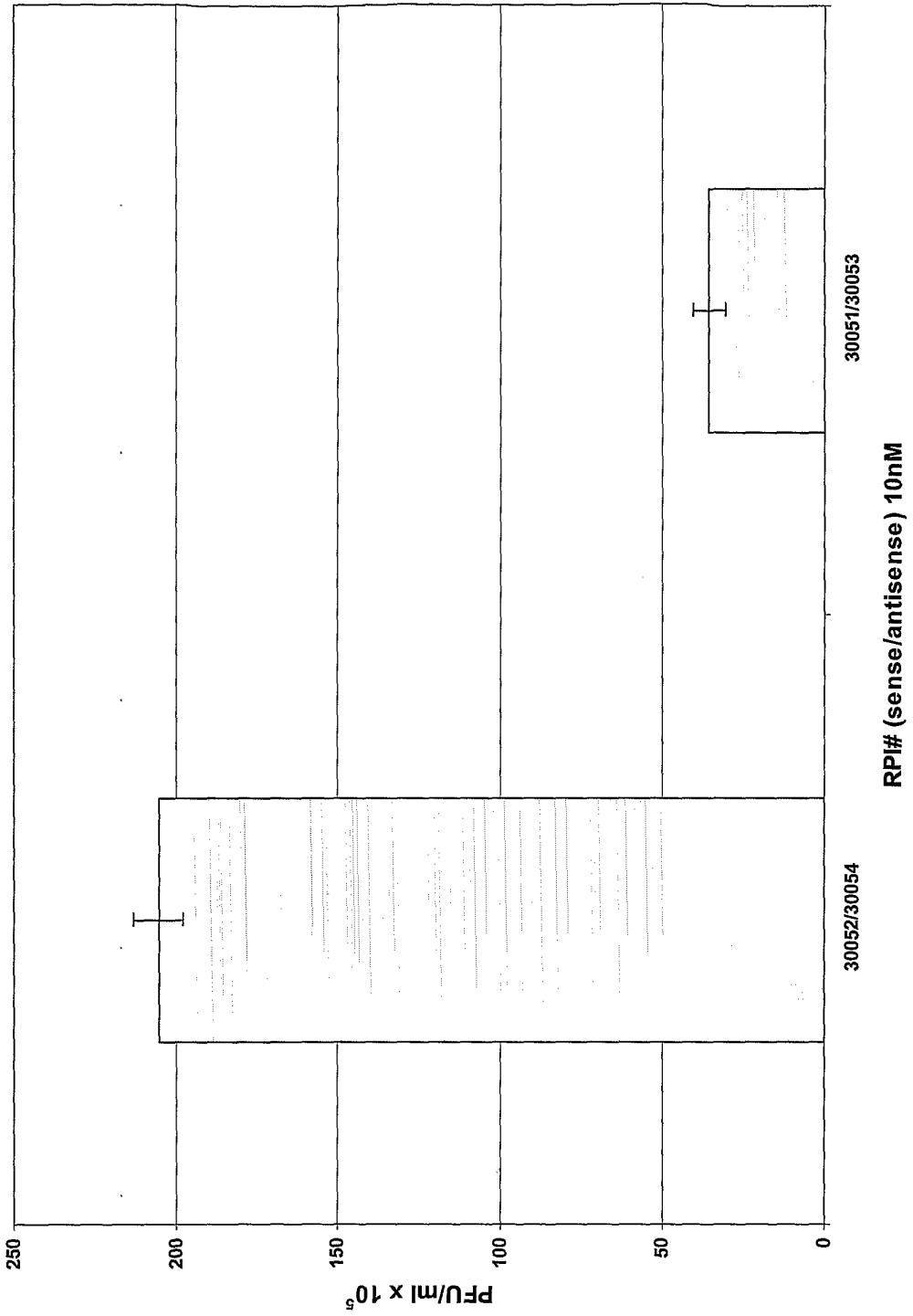
*Figure 32 : siRNAs targeting HCV chimera*



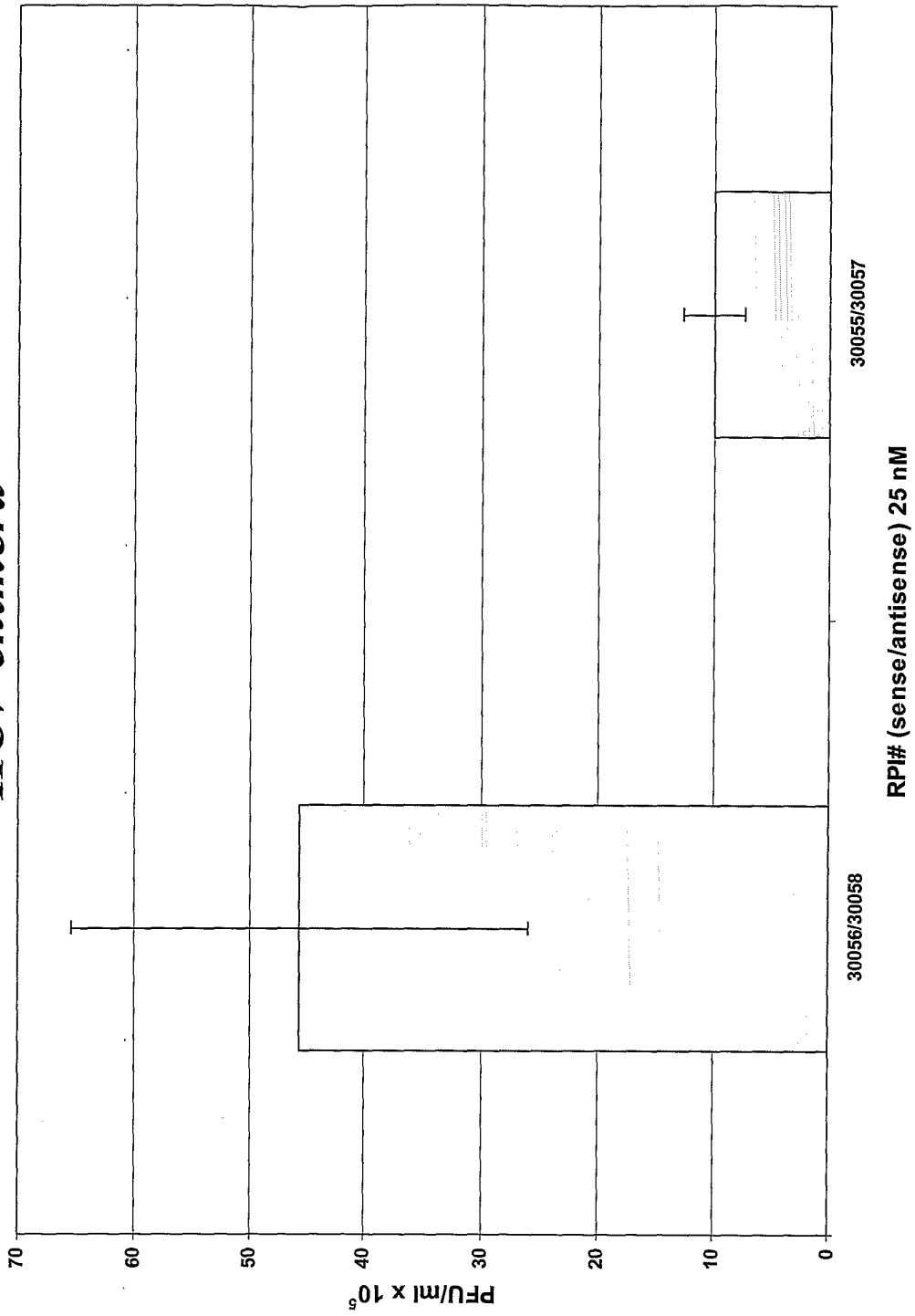
**Figure 33: HCV siRNA dose response**



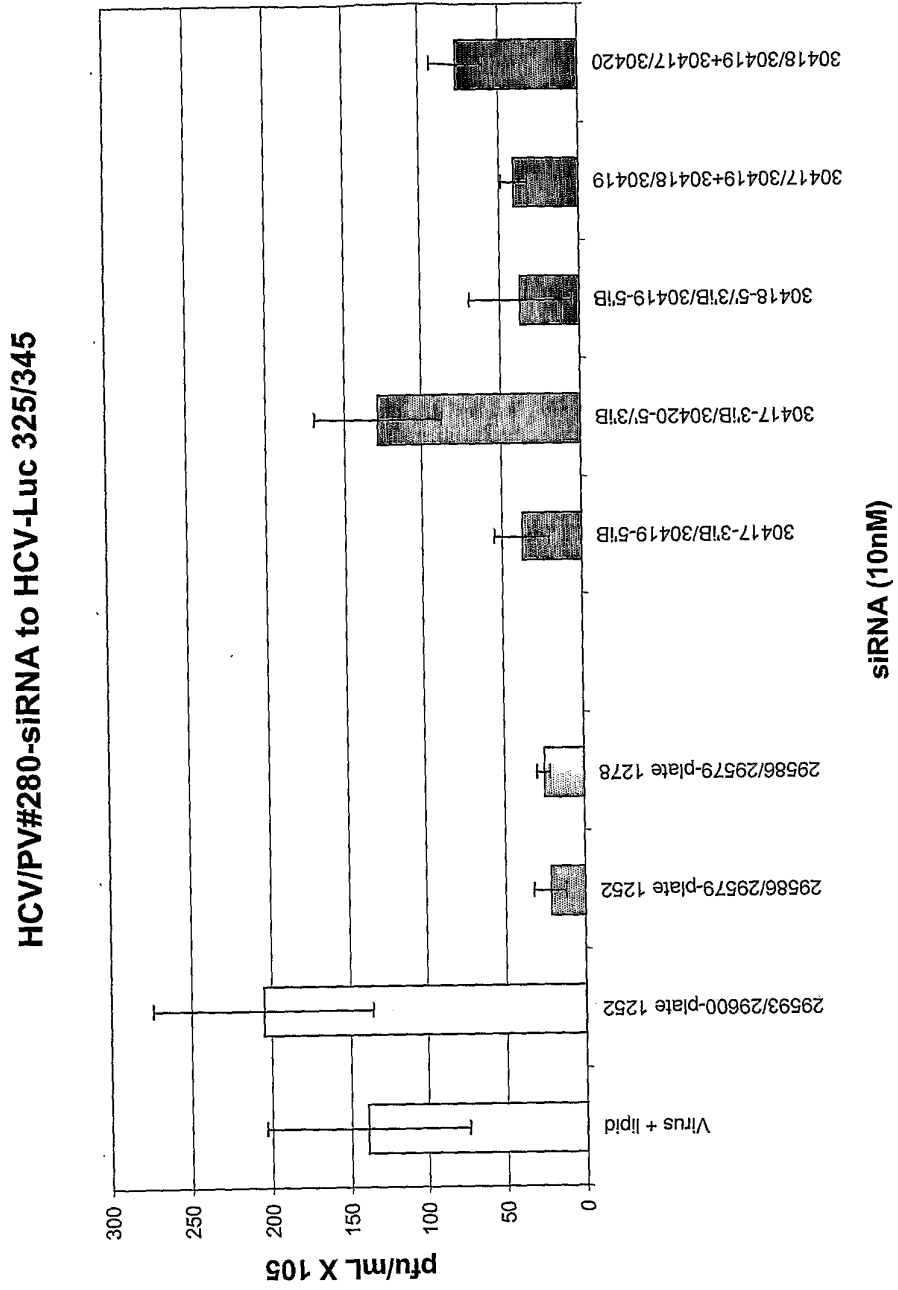
**Figure 34: Chemically Modified siRNA targeting  
HCV chimera**



**Figure 35: Chemically Modified siRNA targeting  
HCV chimera**



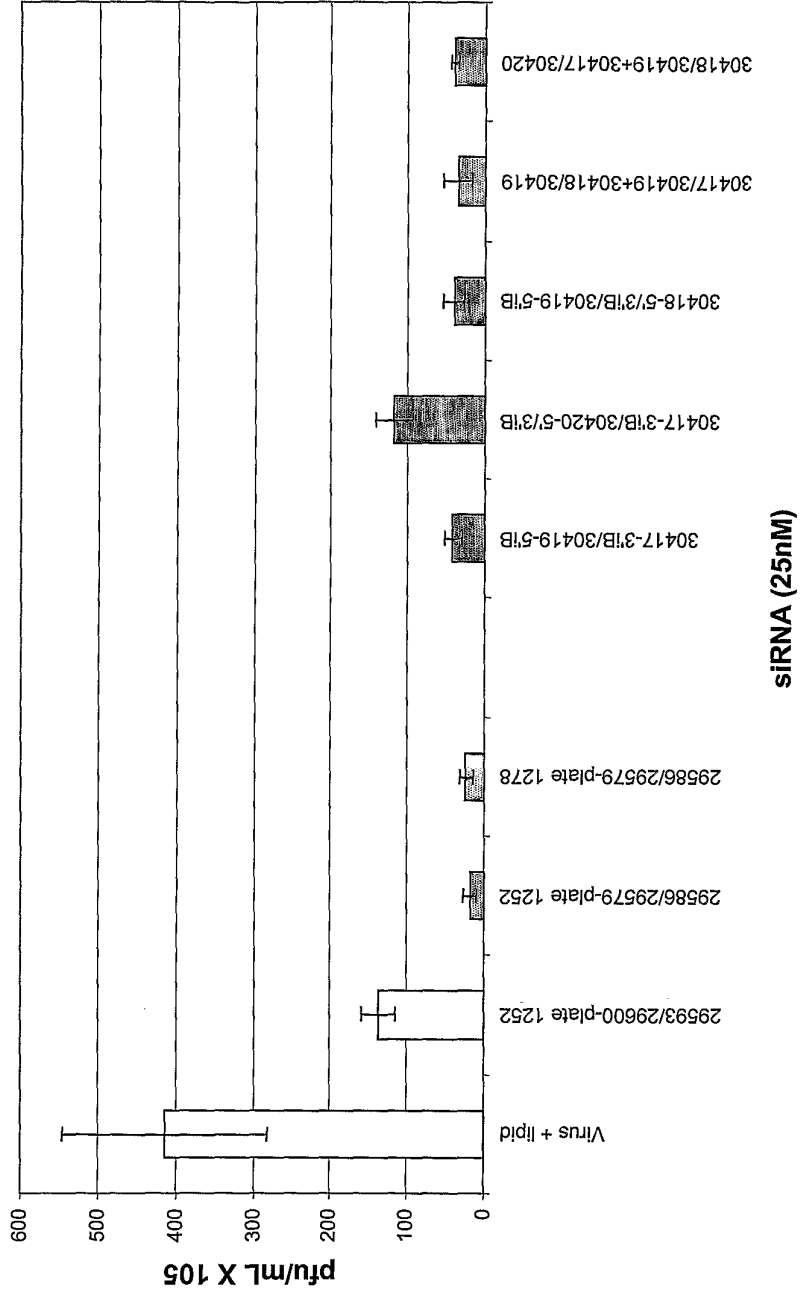
**Figure 36: Chemically Modified siRNA targeting HCV chimera**



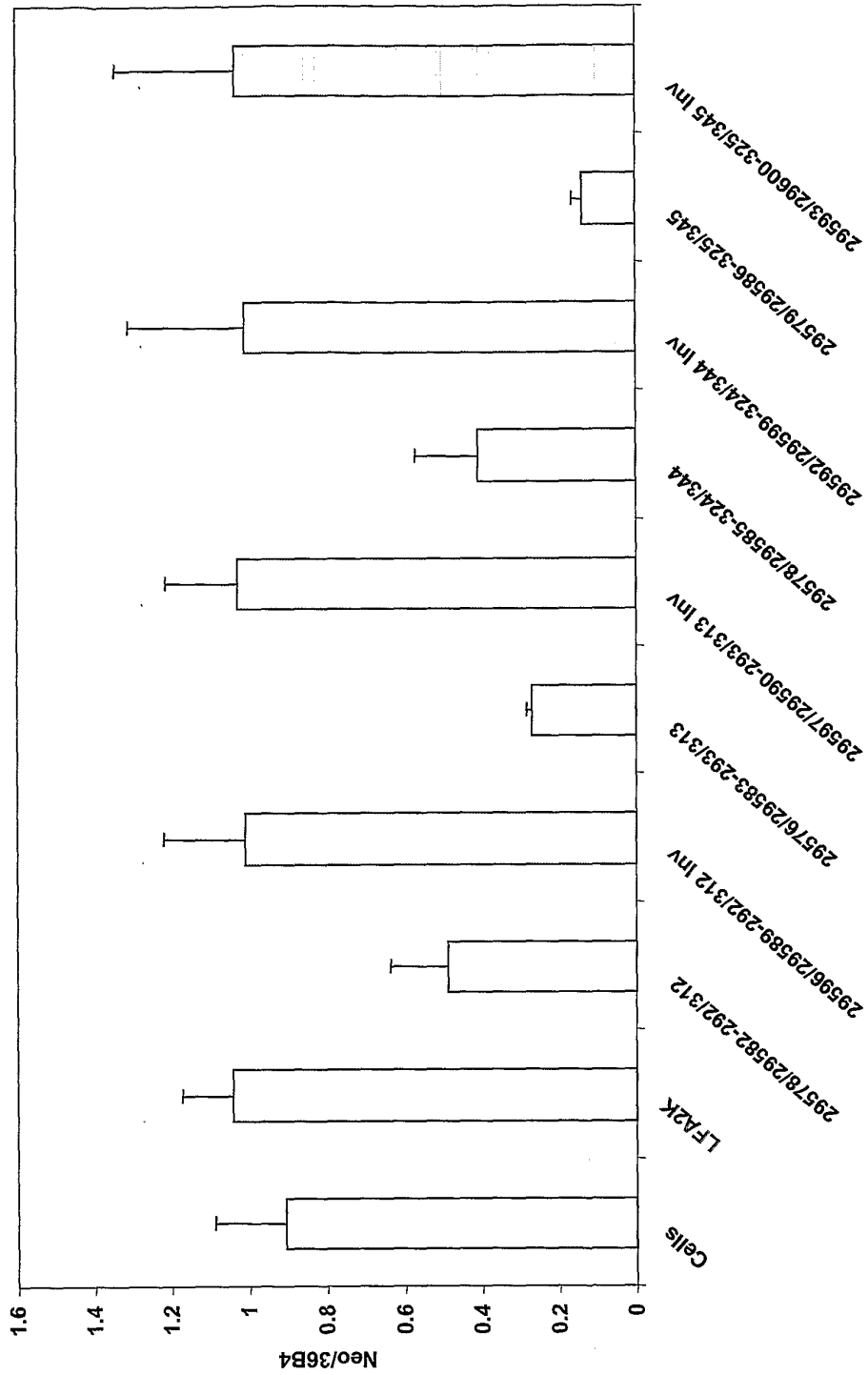


**Figure 37: Chemically Modified siRNA  
targeting HCV chimera**

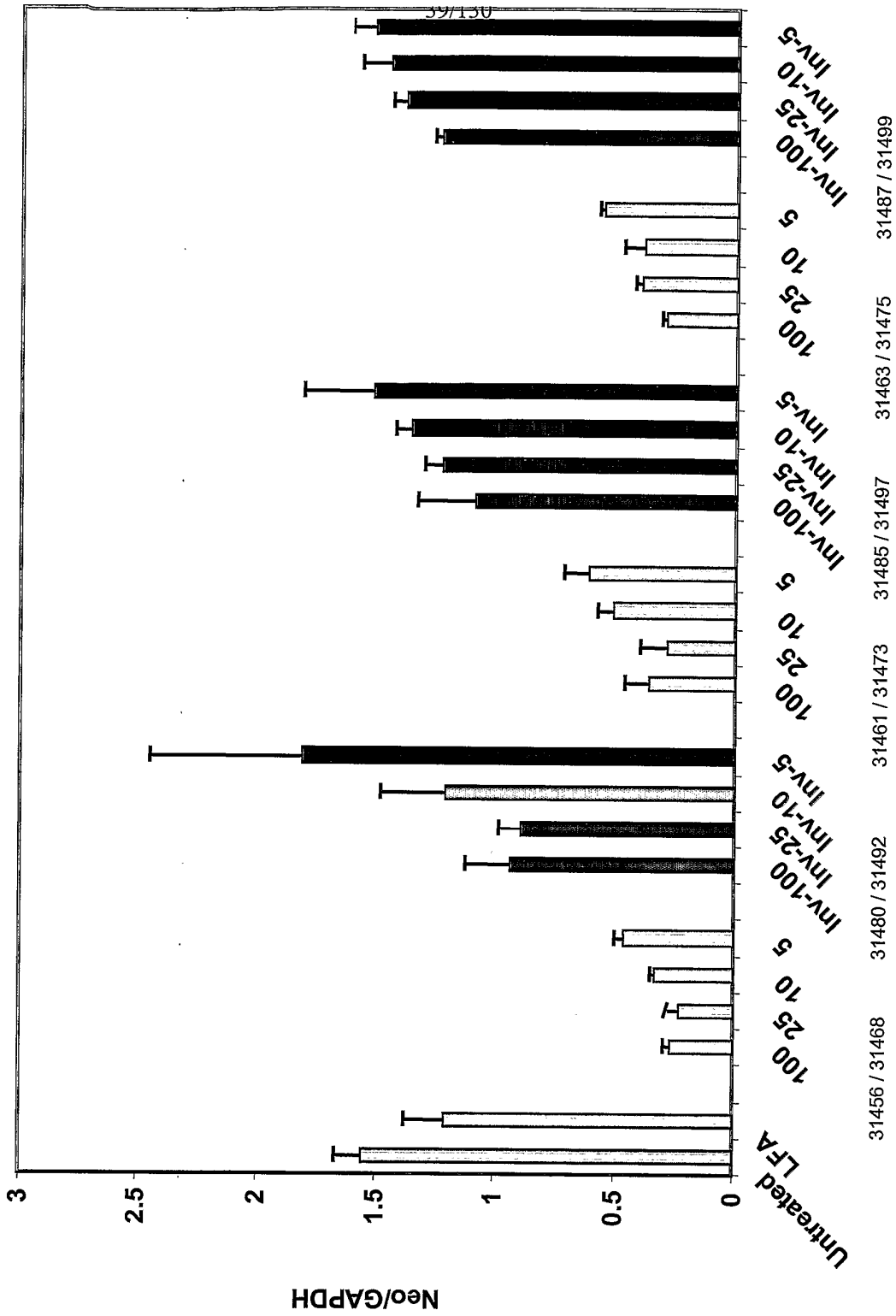
HCV/PV#280-siRNA to HCV-Luc site 325/345



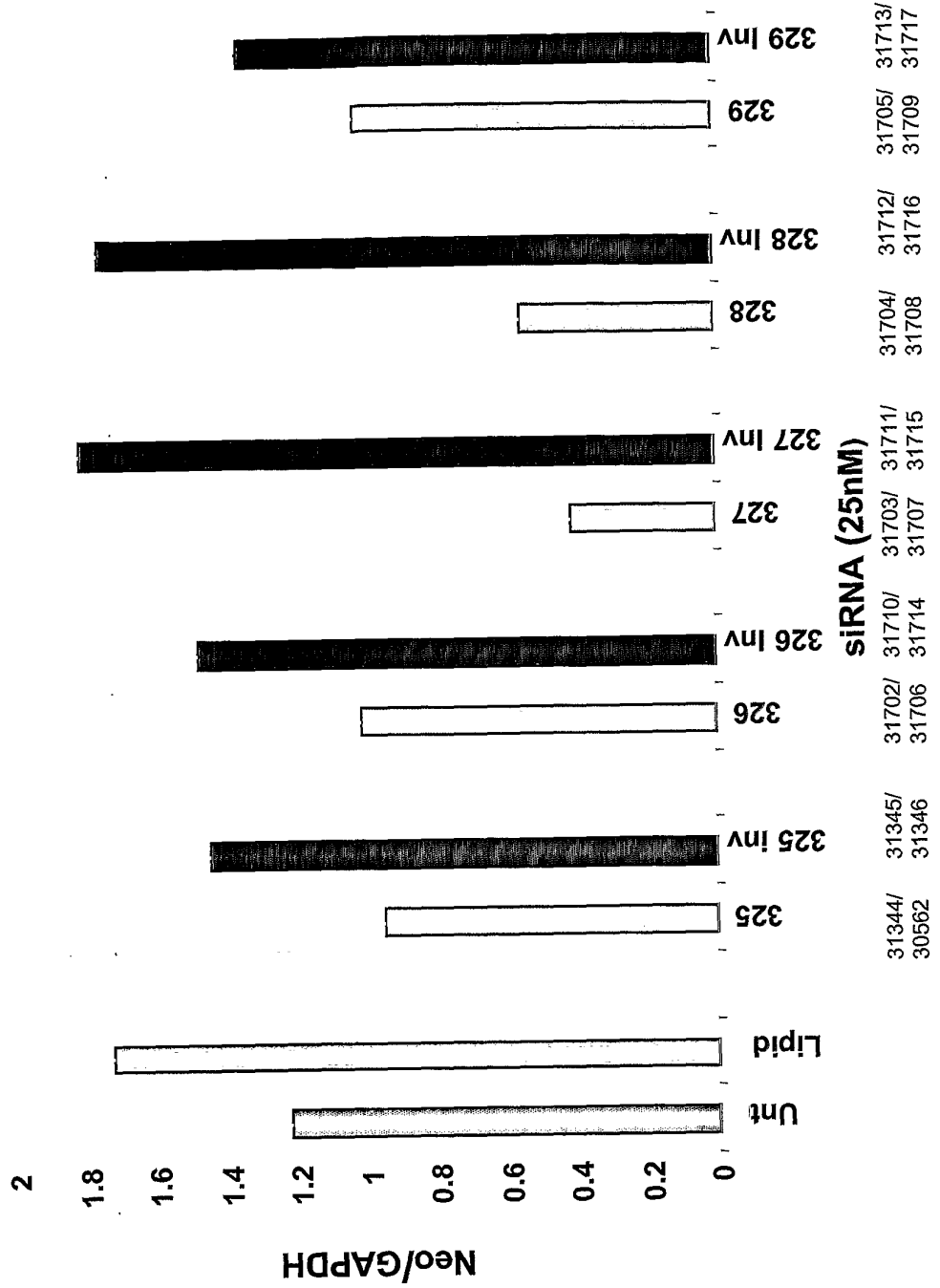
**Figure 38: HCV/Replicon Cells transfected  
with 0.5µl/well LFA 2K-72 hours**



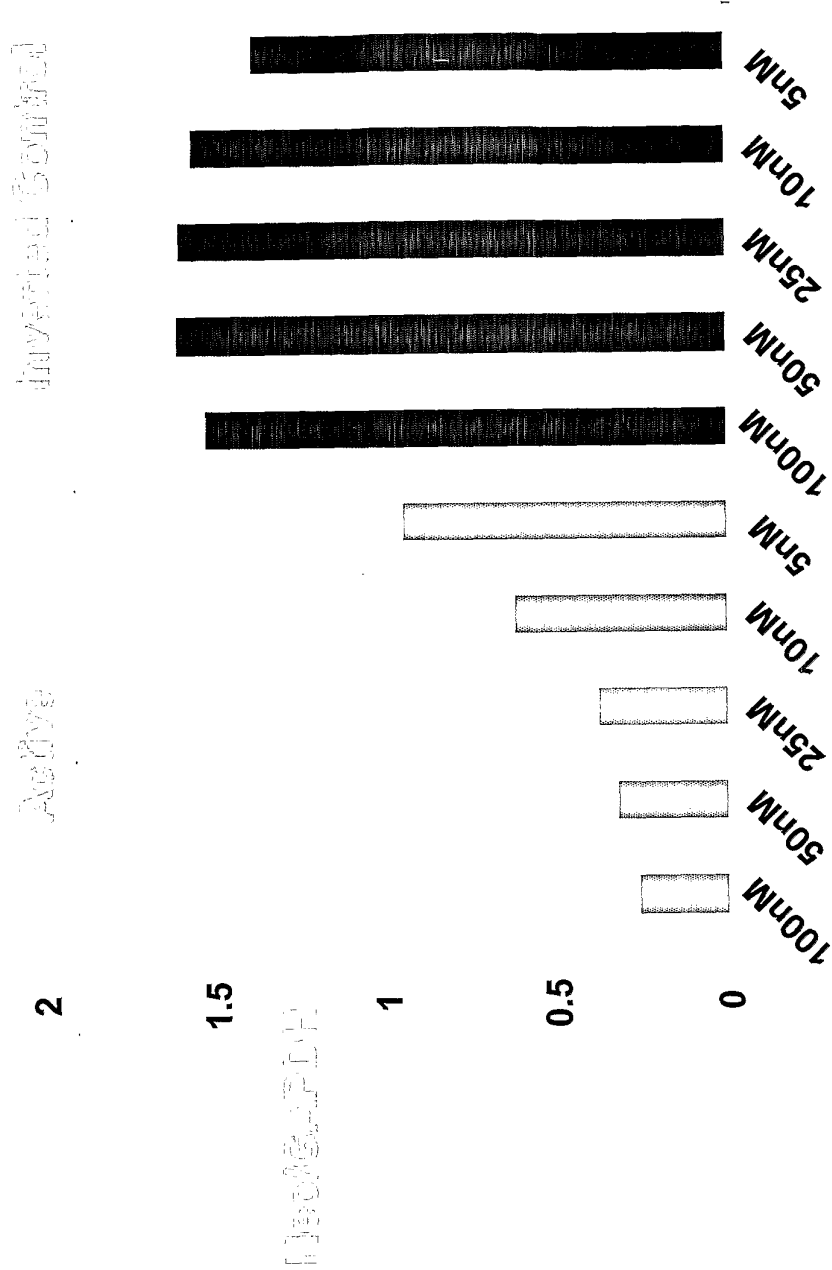
**Figure 39: Dose Response with Stab4/5 siNA Leads in HCV Subgenomic Replicon**



**Figure 40: Activity of Stab 7/8 siNA Leads in HCV Subgenomic Replicon**



**Figure 41: Dose Response with Fully Modified HCV Site 327 siNA**



31711 / 31715

31703 / 31707

**Figure 42: Solid Phase Post-synthetic conjugation of pterotic acid**

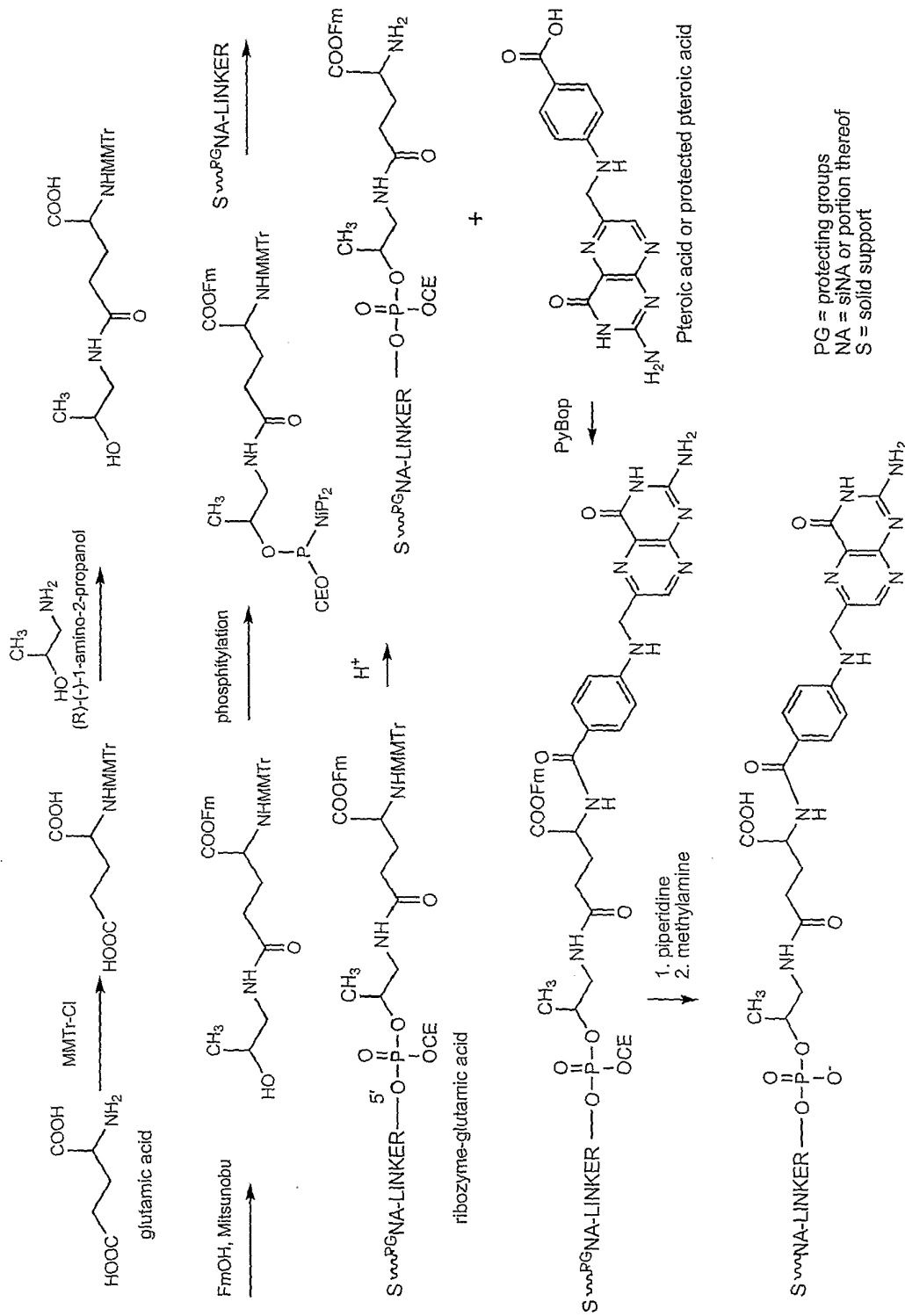
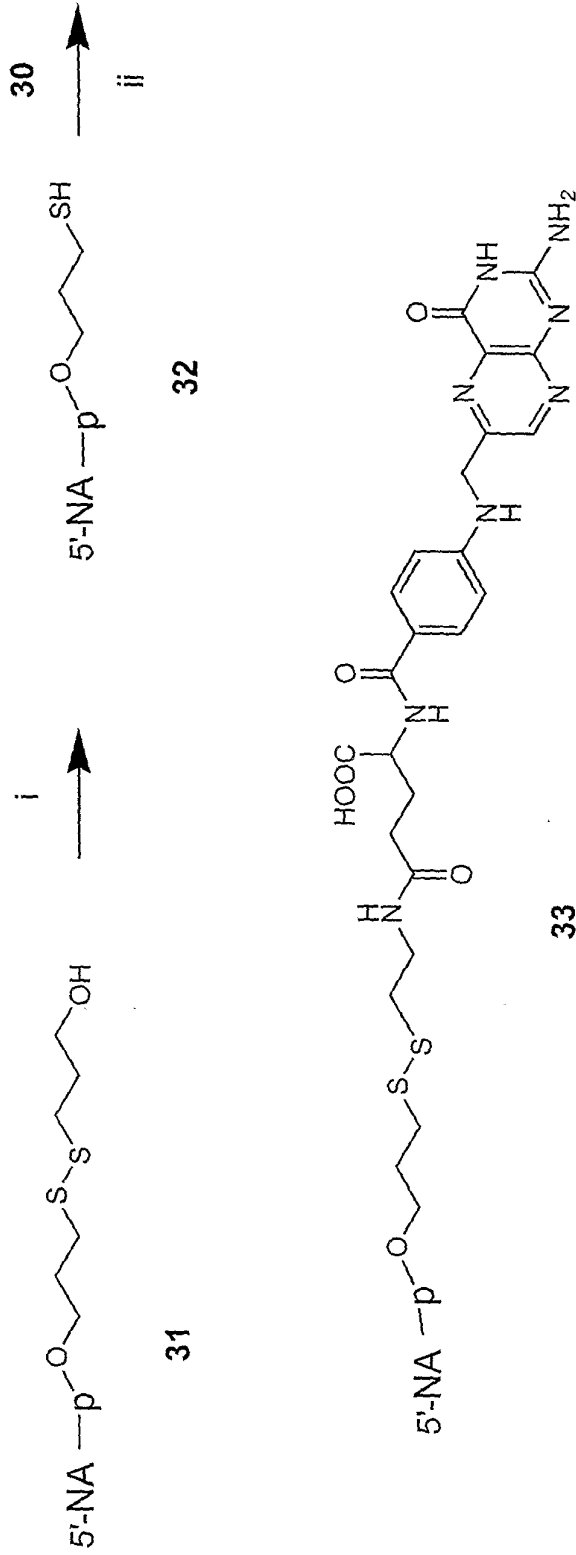
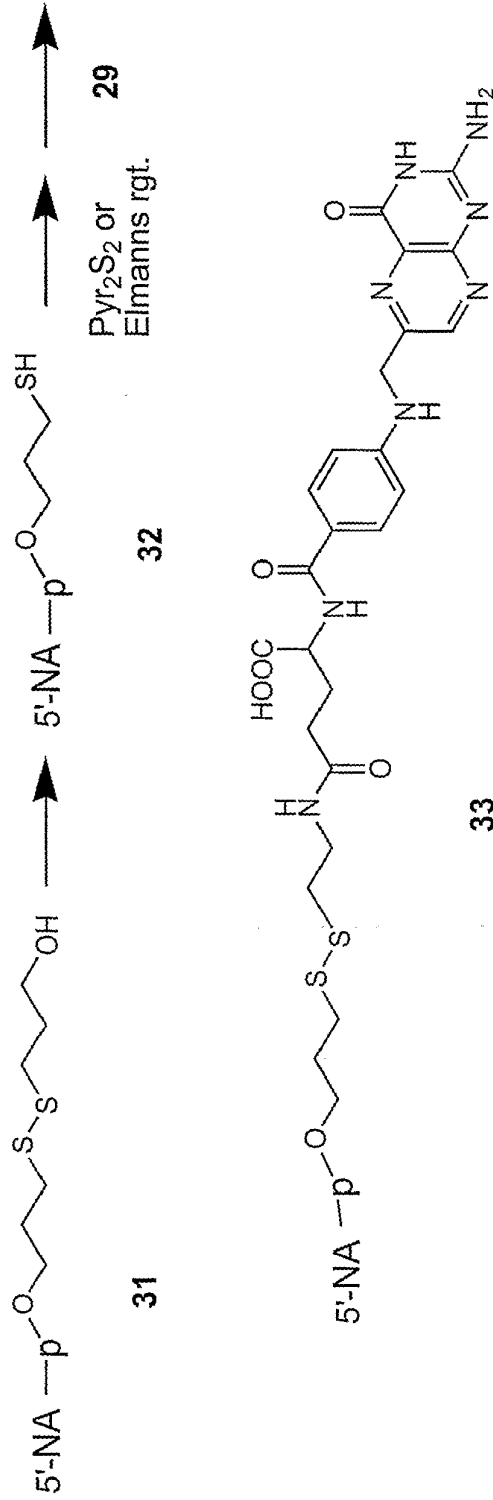


Figure 43



NA = siNA or a portion thereof  
 p = phosphorous moiety

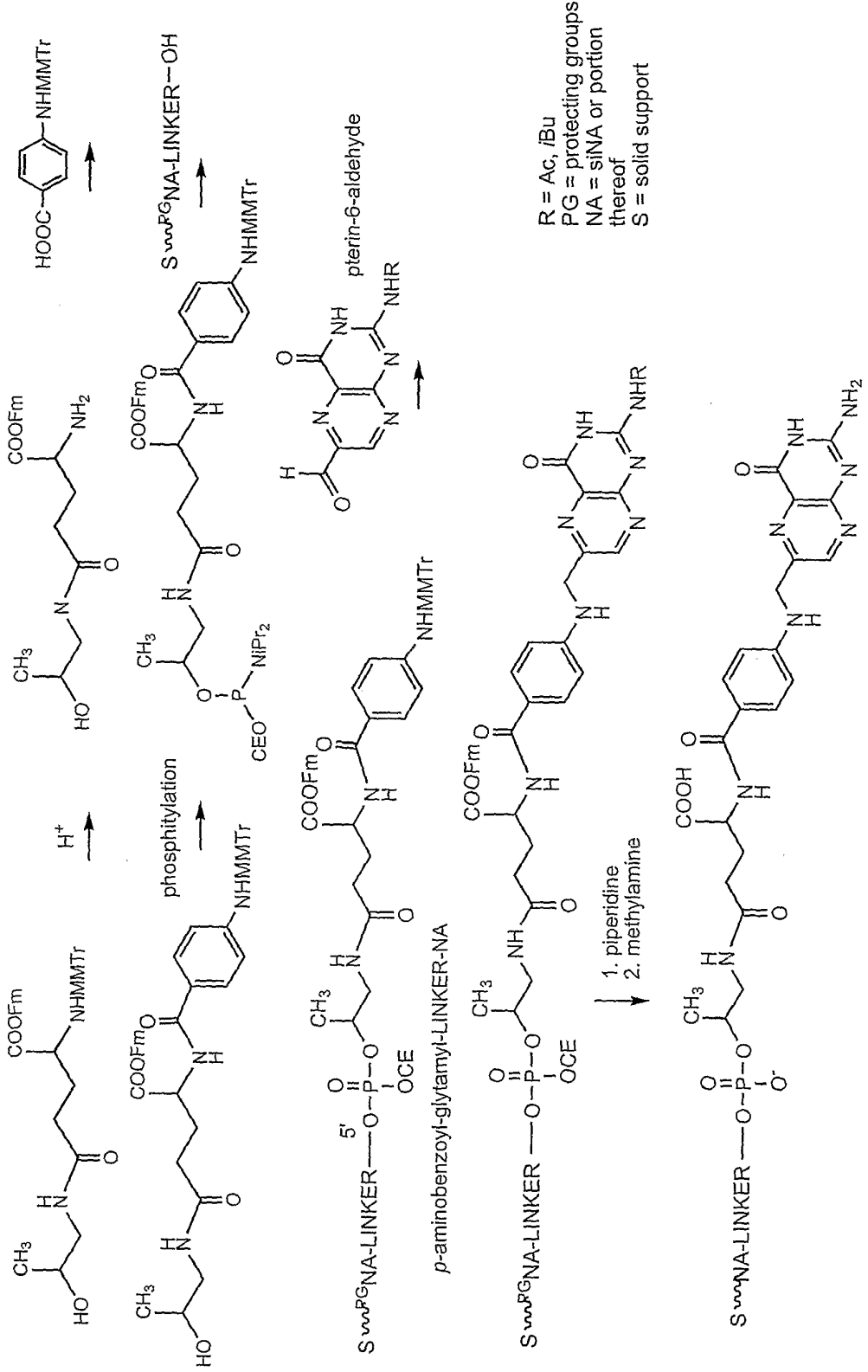
**Figure 44**



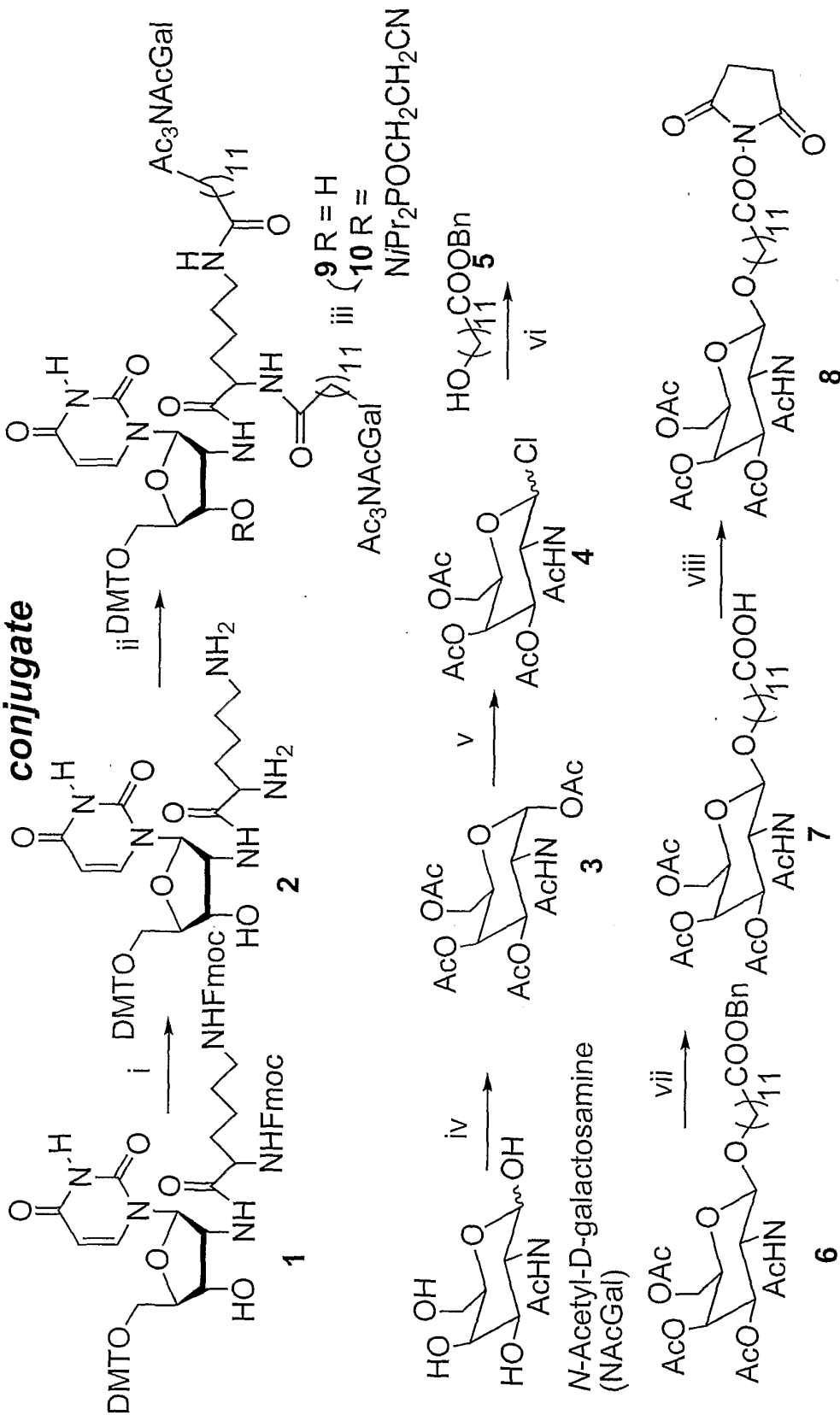
NA = siNA or a portion thereof  
 p = phosphorous moiety



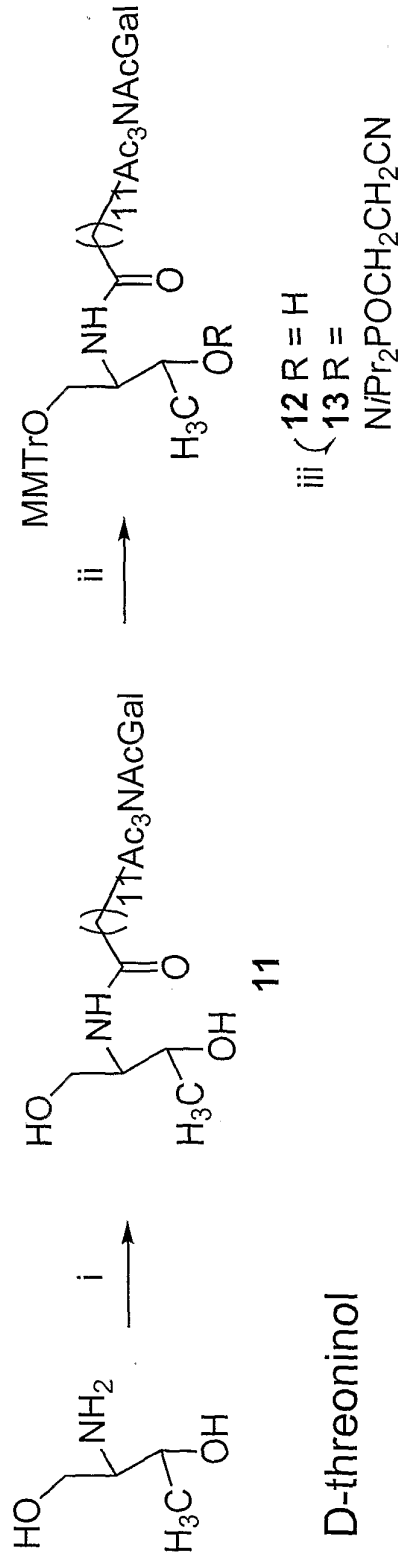
**Figure 45: Solid Phase Post-synthetic conjugation of pterotic acid**



**Figure 46: Synthesis of N-acetyl-D-galactosamine-2'-aminouridine conjugate**

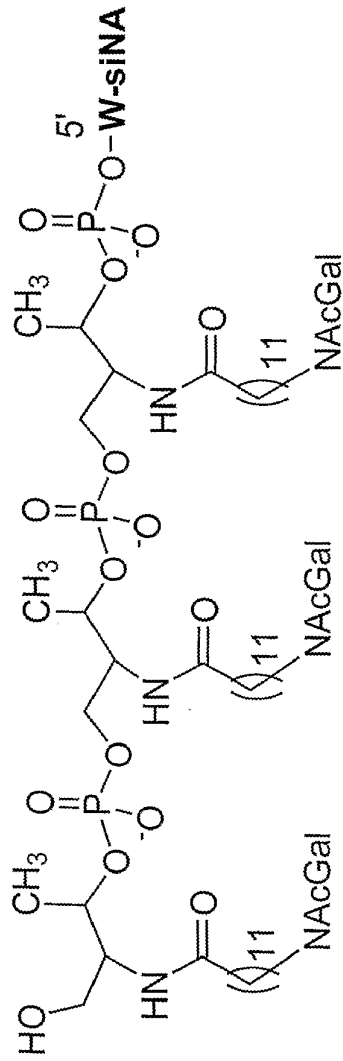


**Figure 47: Synthesis of N-acetyl-D-galactosamine-D-threoninol conjugate**



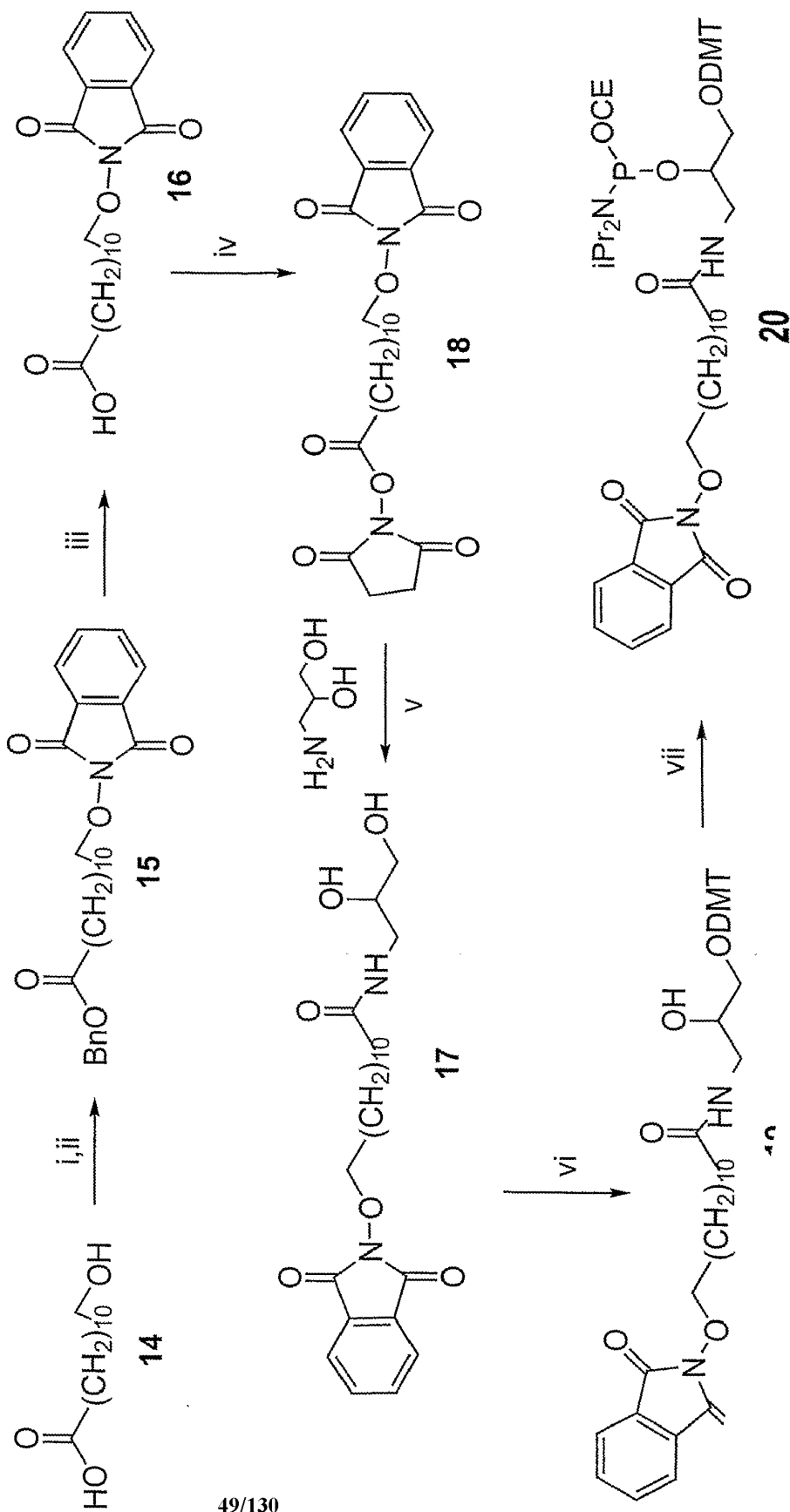
Reagents and Conditions: (i) 7, DCC, N-hydroxysuccinimide, (ii) MMTr-Cl, pyridine, (iii) 2-cyanoethyl N,N-diisopropylchlorophosphoramidite, 1-methylimidazole, DIPEA,  $CH_2Cl_2$ .

**Figure 48: Conjugation of targeting ligands to the 5'-end of a siNA molecule**

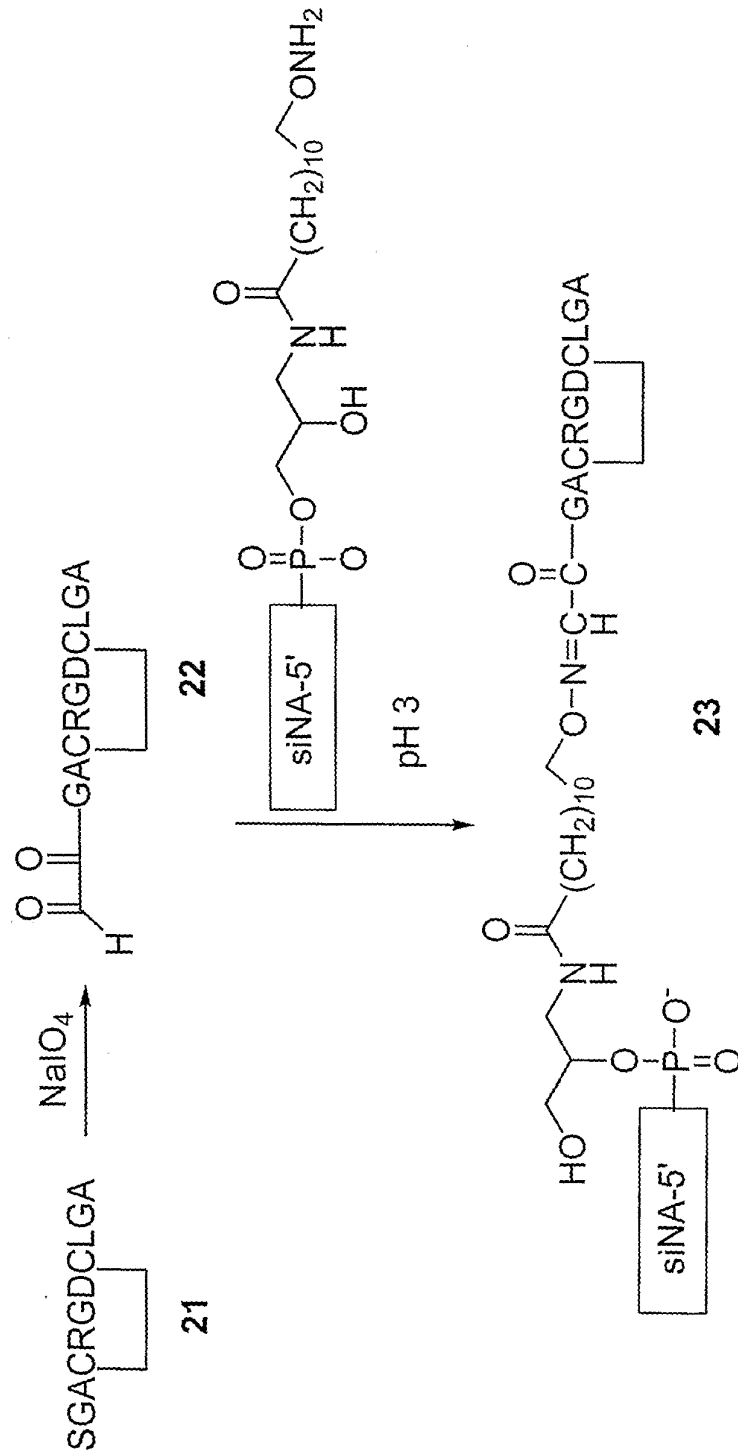


**N-acetyl-D-galactosamine conjugate**

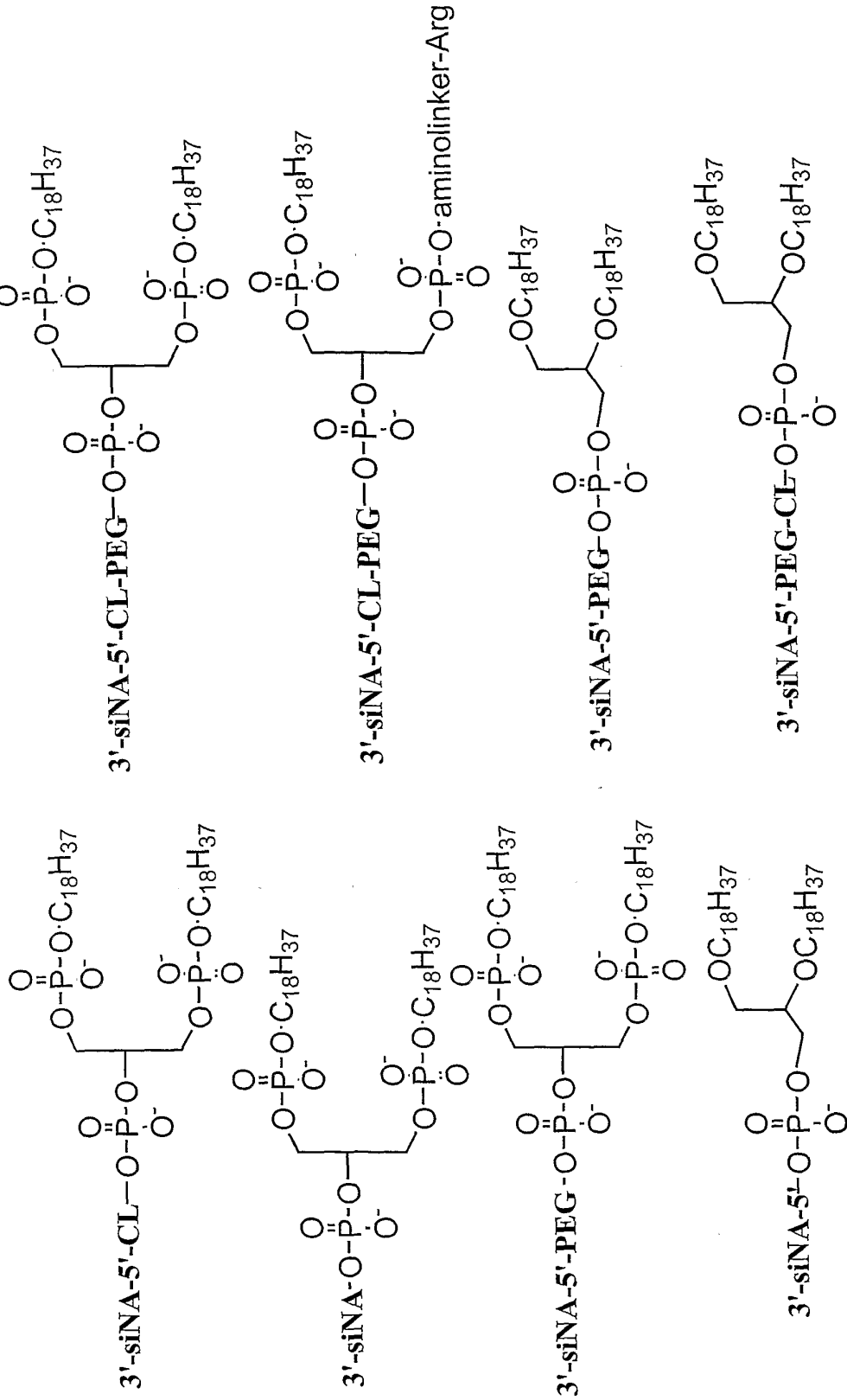
**Figure 49: Synthesis of dodecanoic acid linker**



**Figure 50: Oxime linked siNA/Peptide Conjugate**

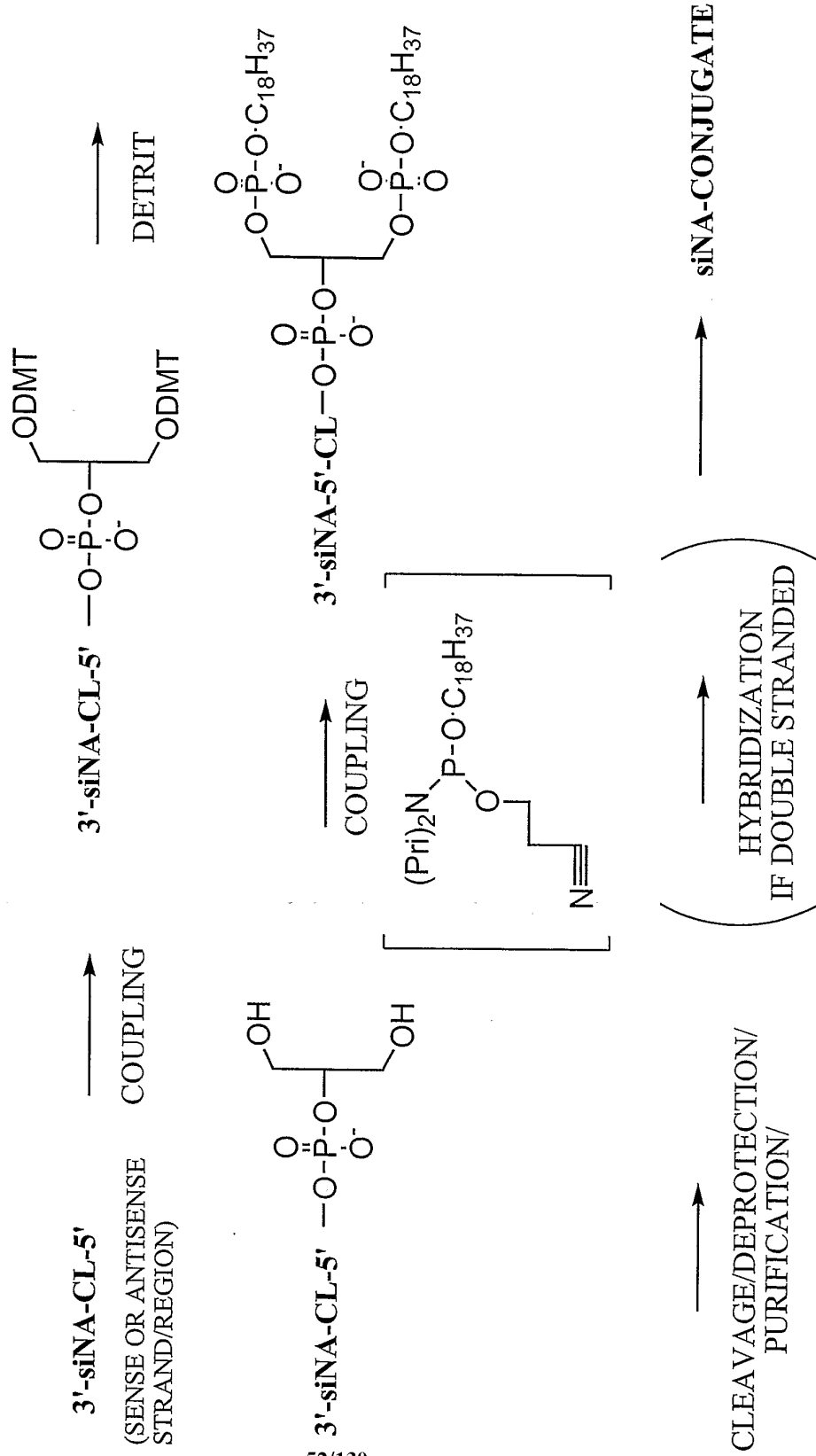


**Figure 51: siNA/Phospholipid Conjugates**



PEG=polyethylene glycol  
 CL=cleavable linker (e.g. A-dT, C-dT)  
 siNA= short interfering nucleic acid molecule or a portion thereof

**Figure 52: siNA Phospholipid Conjugate**

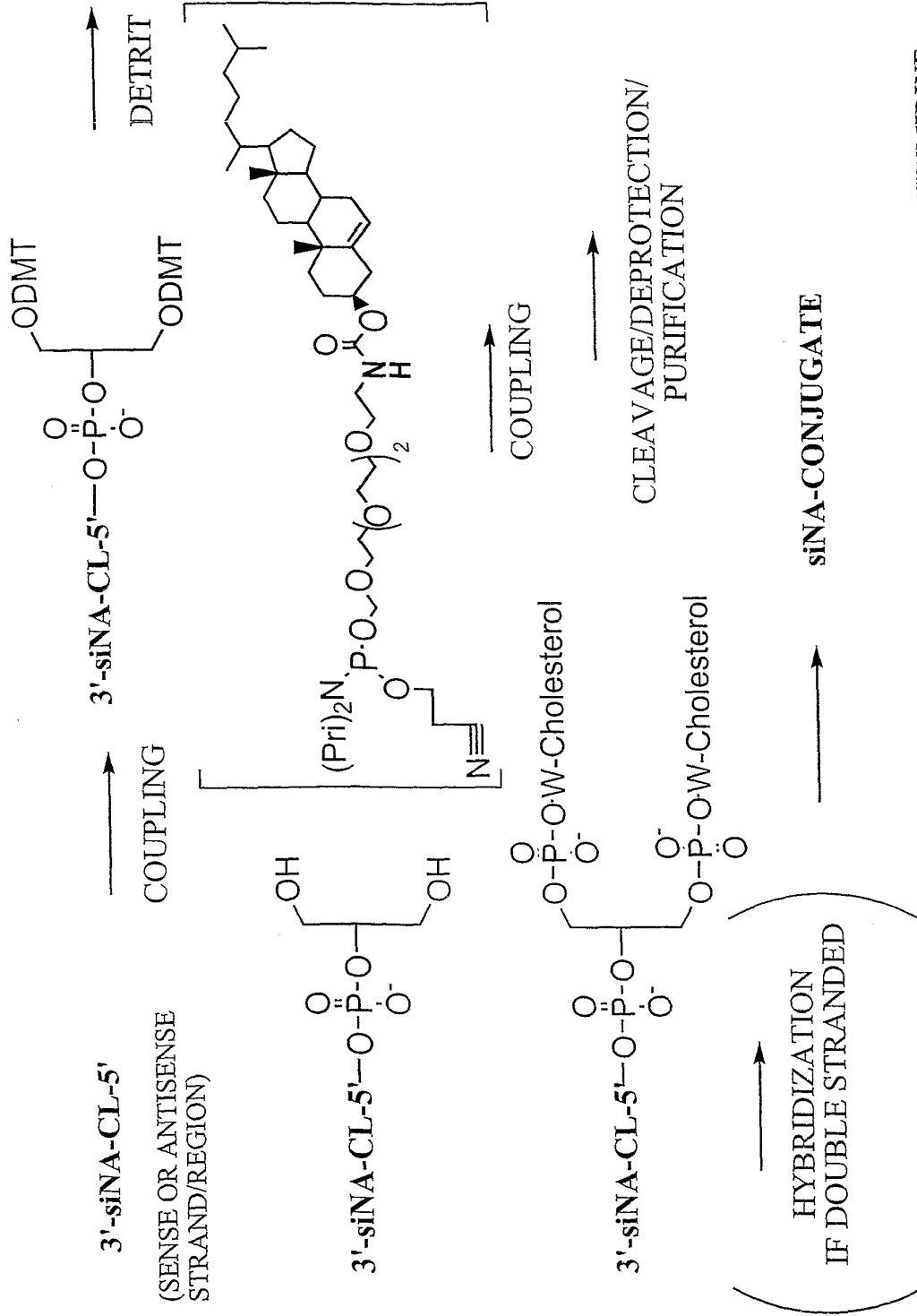


CL = CLEAVABLE LINKER, E.G. ADENOSINE-THYMIDINE DIMER THAT IS OPTIONALLY PRESENT



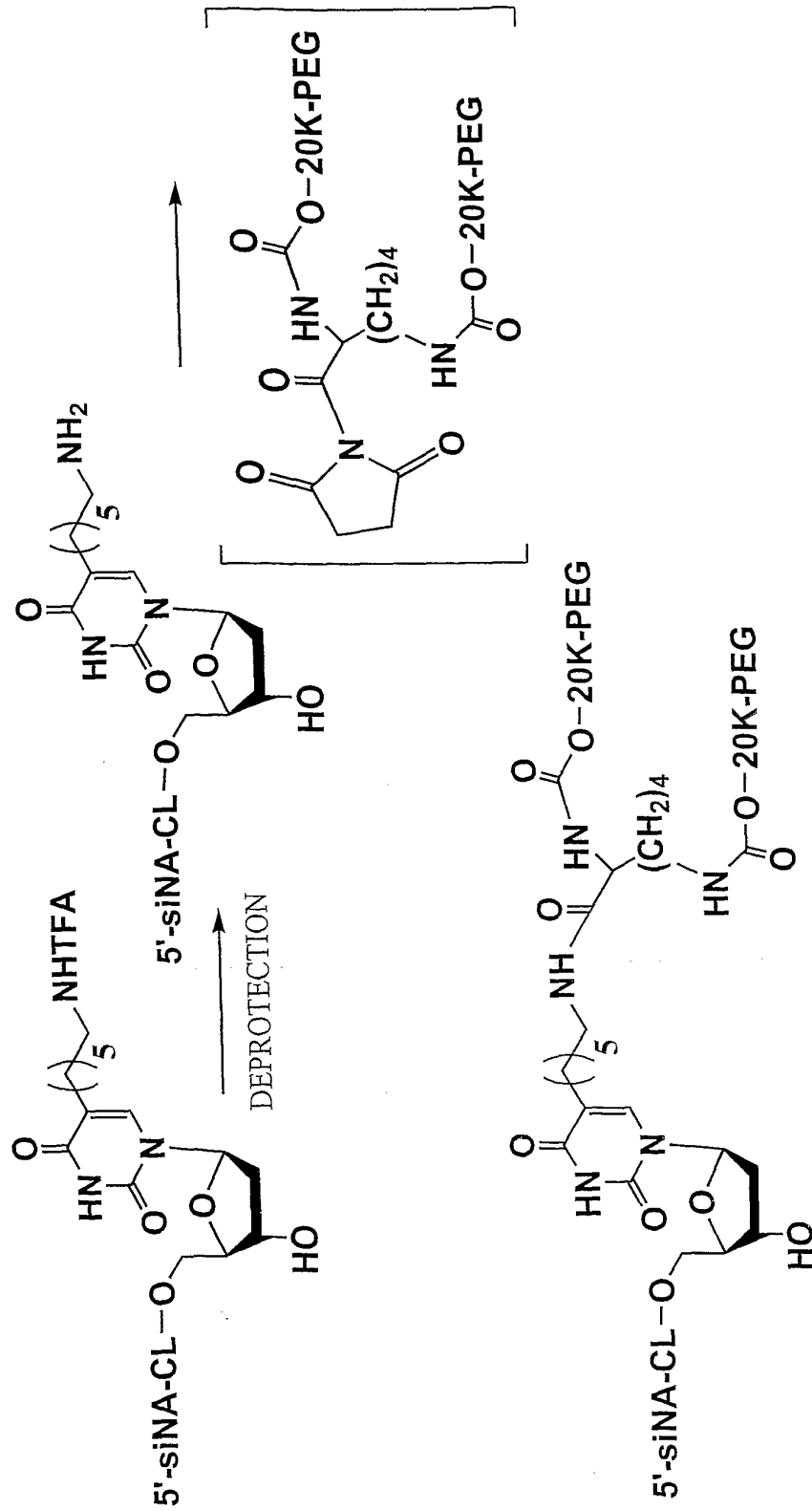


**Figure 54: siNA Cholesterol Conjugate**



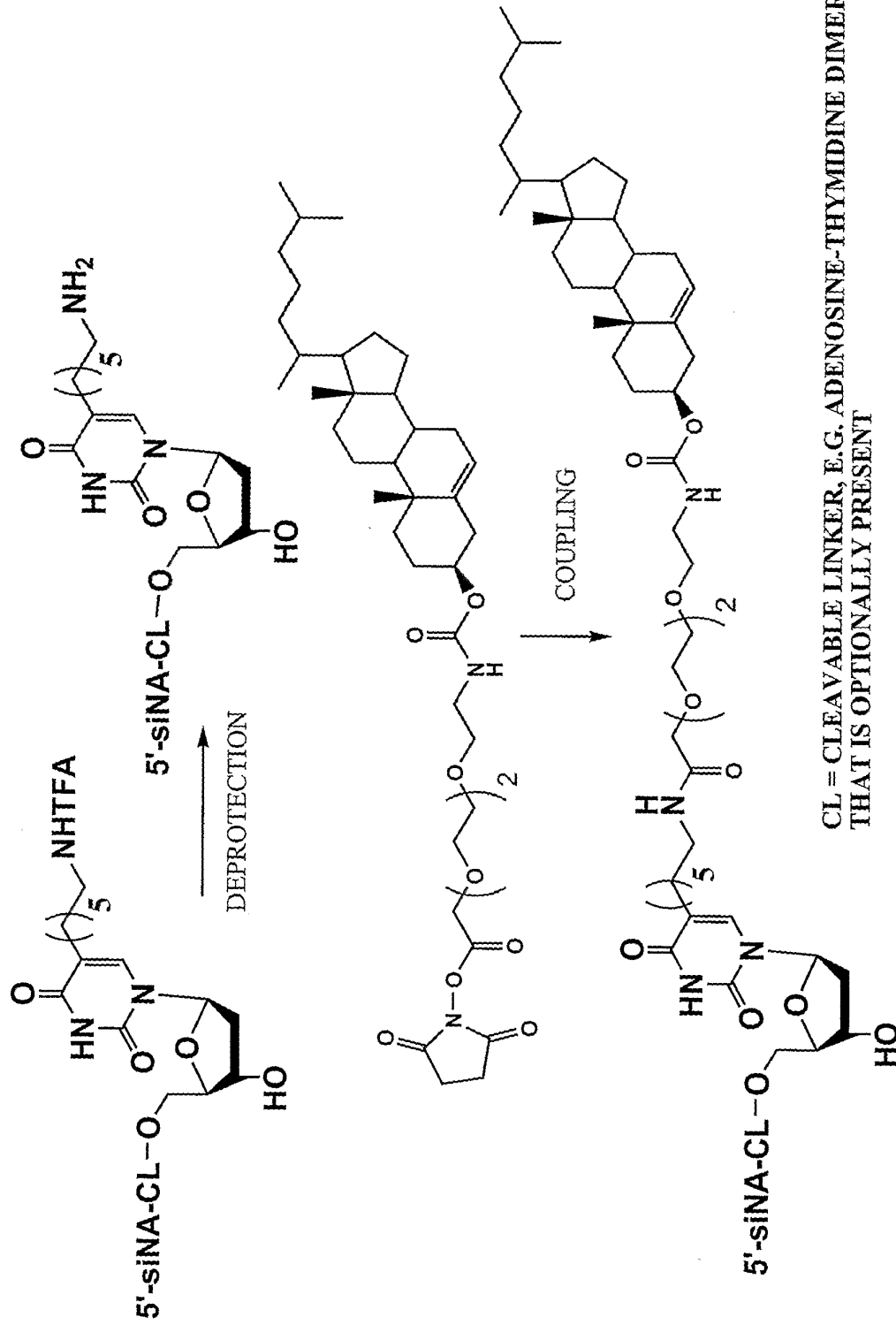
CL = CLEAVABLE LINKER, E.G. ADENOSINE-THYMIDINE DIMER THAT IS OPTIONALLY PRESENT

*Figure 55: siNA 3'-PEG Conjugate*

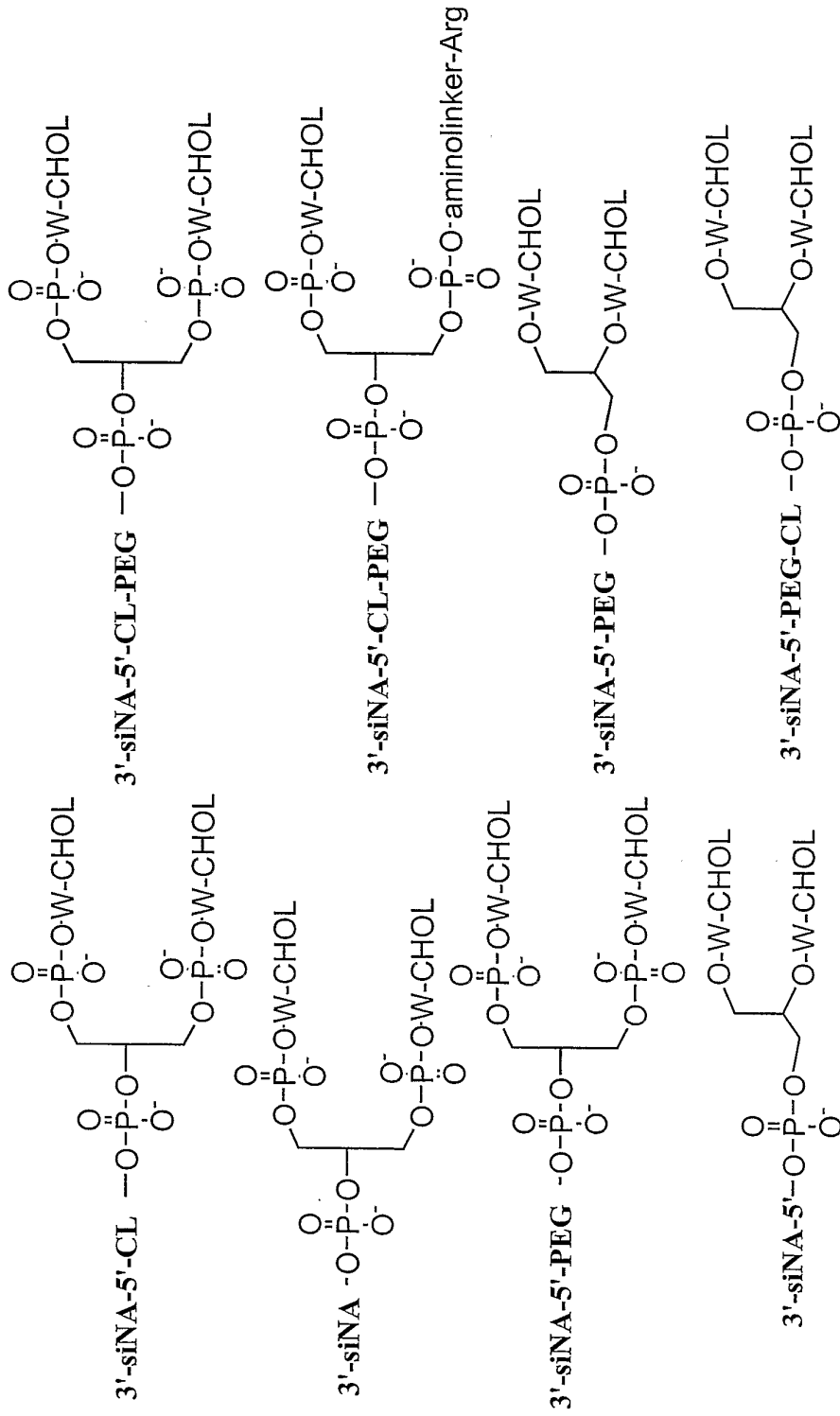


CL = CLEAVABLE LINKER, E.G. ADENOSINE-THYMIDINE DIMER THAT IS OPTIONALLY PRESENT

**Figure 56: siNA 3'-Cholesterol Conjugate**

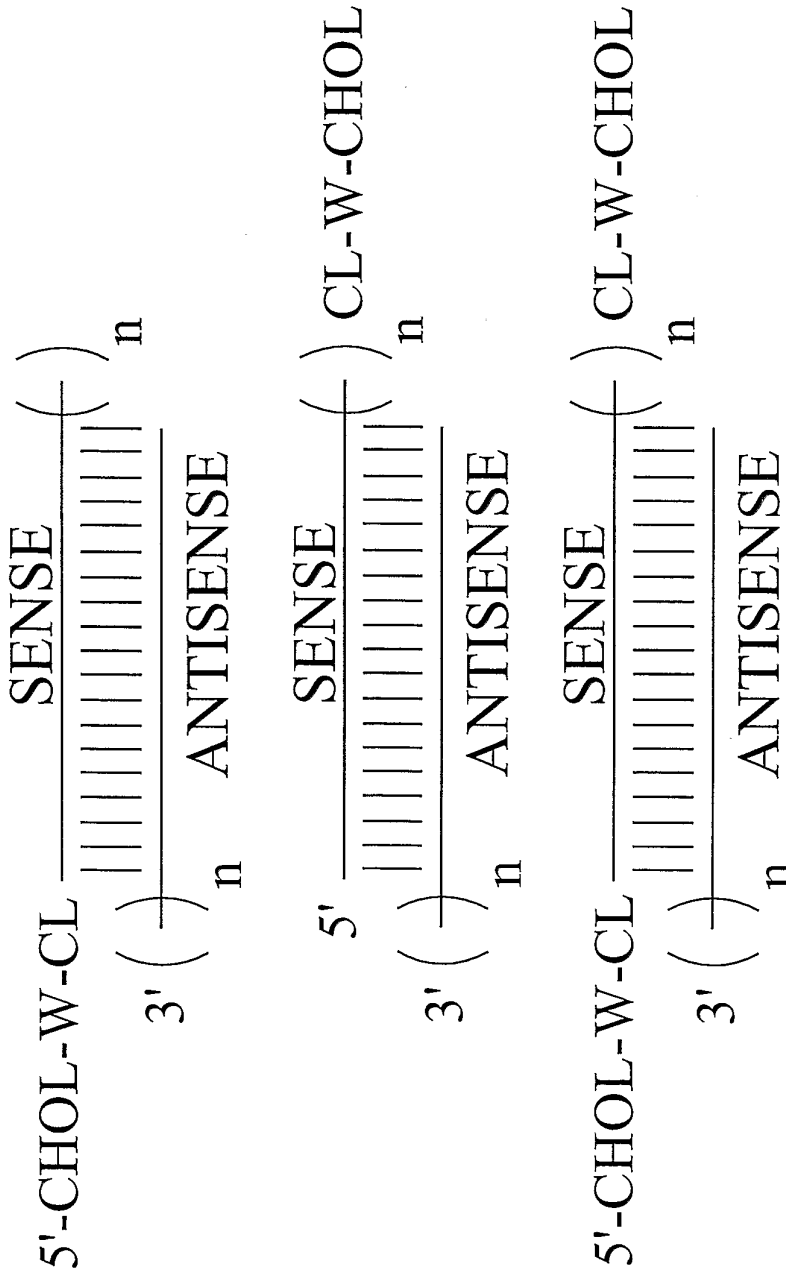


**Figure 57: Nucleic Acid Cholesterol Conjugates**



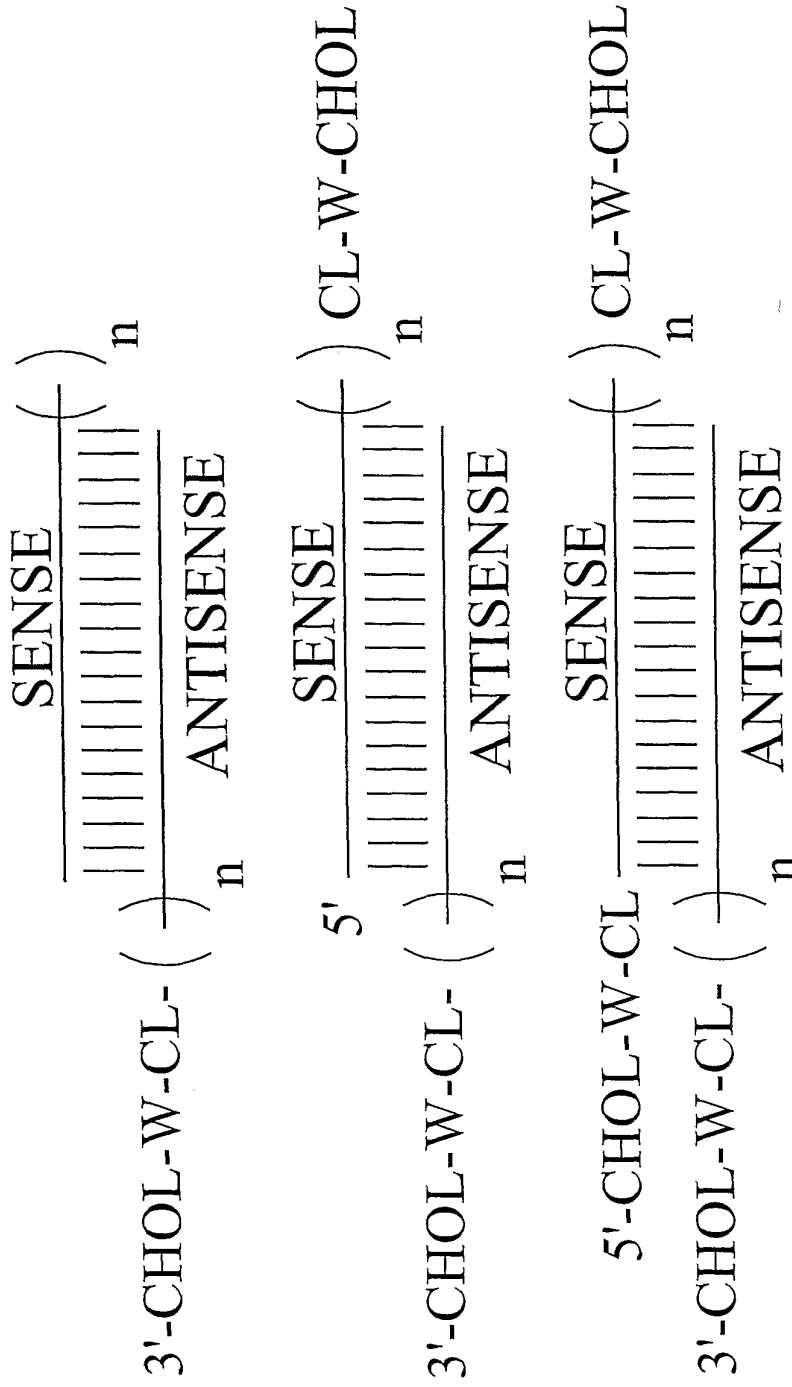
PEG=polyethylene glycol  
 CL=cleavable linker (e.g. A-dT, C-dT)  
 siNA= short interfering nucleic acid molecule or a portion thereof  
 CHOL=cholesterol or an analog or metabolite thereof  
 W= linker molecule (see for example Formulae 109 or 112)

*Figure 58: siNA Cholesterol Conjugates*



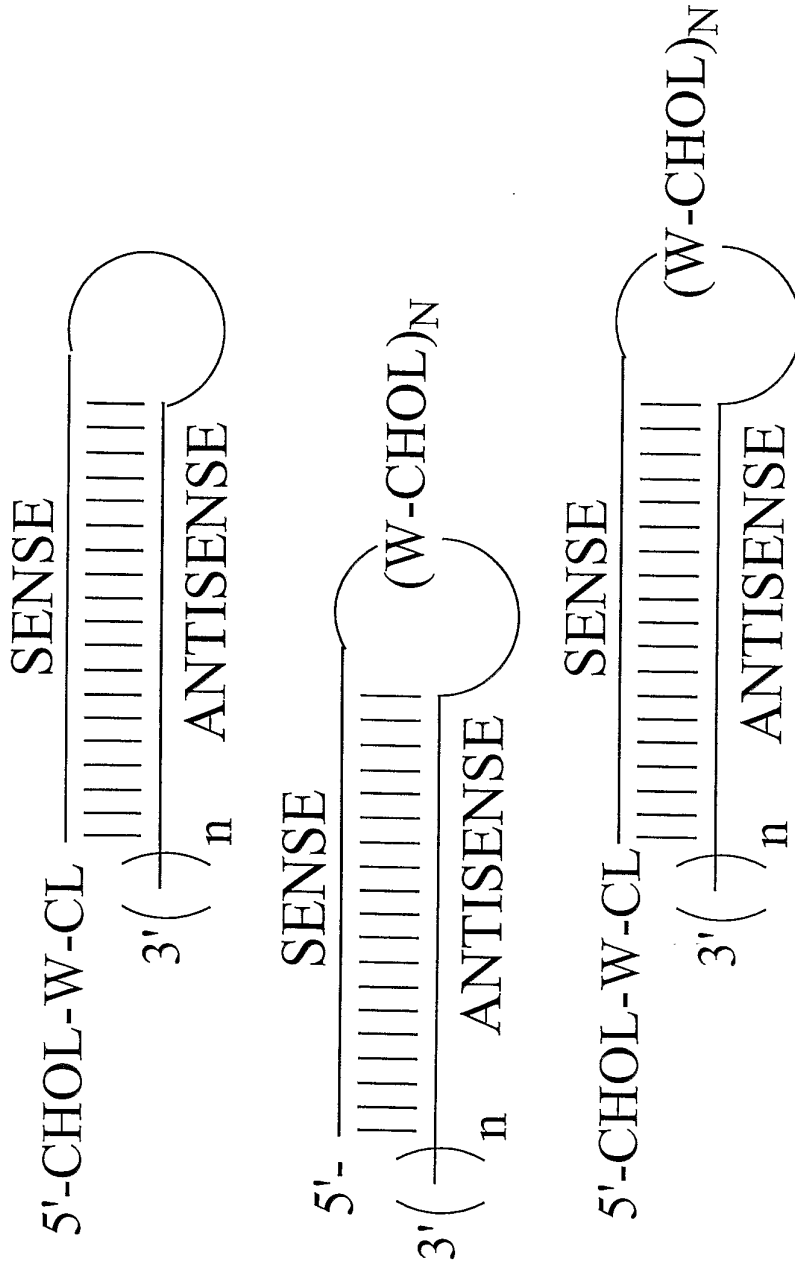
CL=cleavable linker (e.g. A-dT, C-dT) that is optionally present  
 CHOL=cholesterol or an analog or metabolite thereof  
 W= linker molecule (see for example Formulae 107, 108, 109 or 115)  
 n = integer, e.g. 1, 2, or 3

*Figure 59: siNA Cholesterol Conjugates*



CL=cleavable linker (e.g. A-dT, C-dT) that is optionally present  
 CHOL=cholesterol or an analog or metabolite thereof  
 W= linker molecule (see for example Formulae 107, 108, 109 or 115)  
 n = integer, e.g. 1, 2, or 3

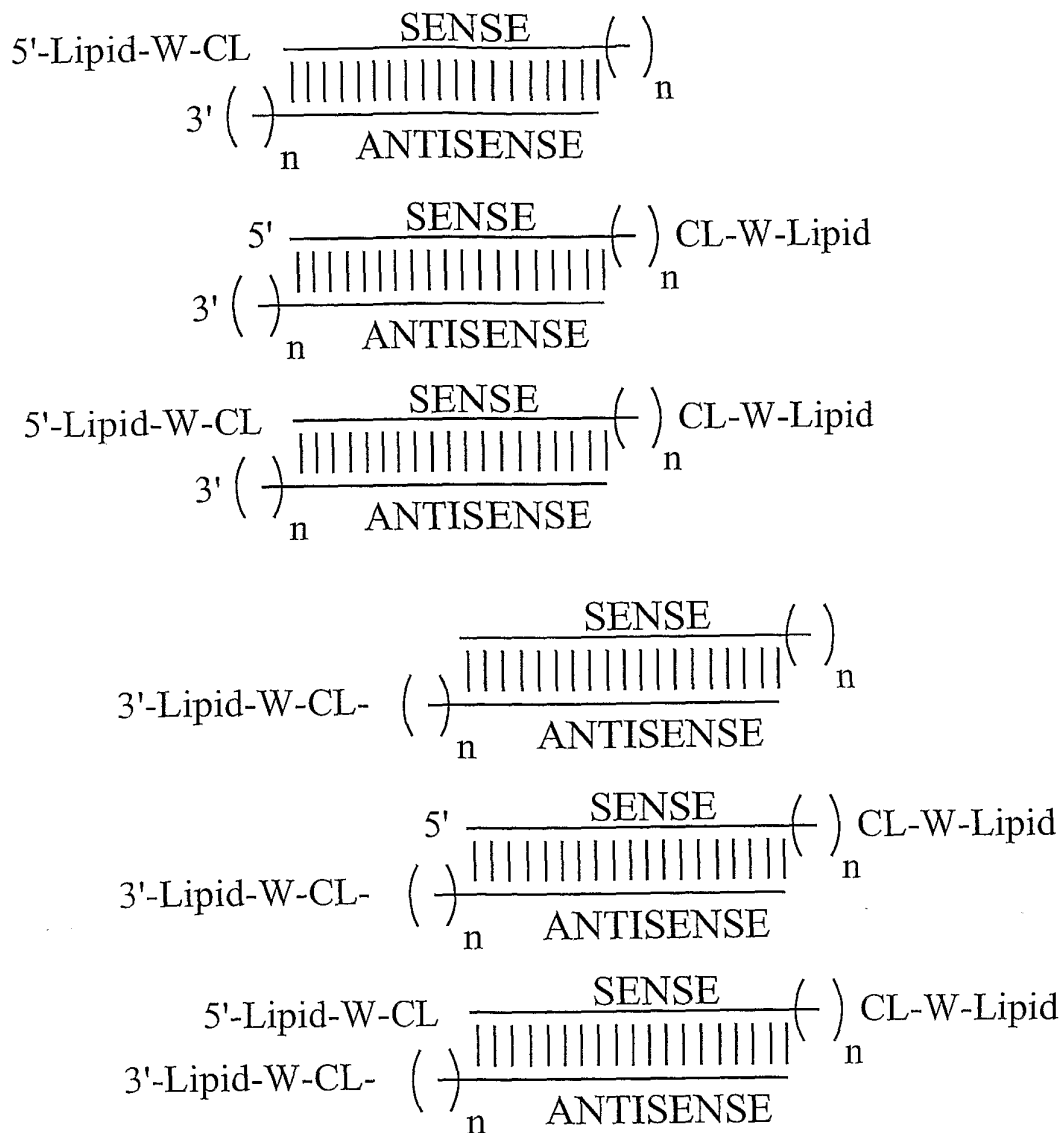
*Figure 60: siNA Cholesterol Conjugates*



CL=cleavable linker (e.g. A-dT, C-dT) that is optionally present  
 CHOL=cholesterol or an analog or metabolite thereof  
 W= linker molecule (see for example Formulae 107, 108, 109 or 112)  
 n = integer, e.g. 1, 2, or 3  
 N=integer, e.g. 1, 2, 3, or 4

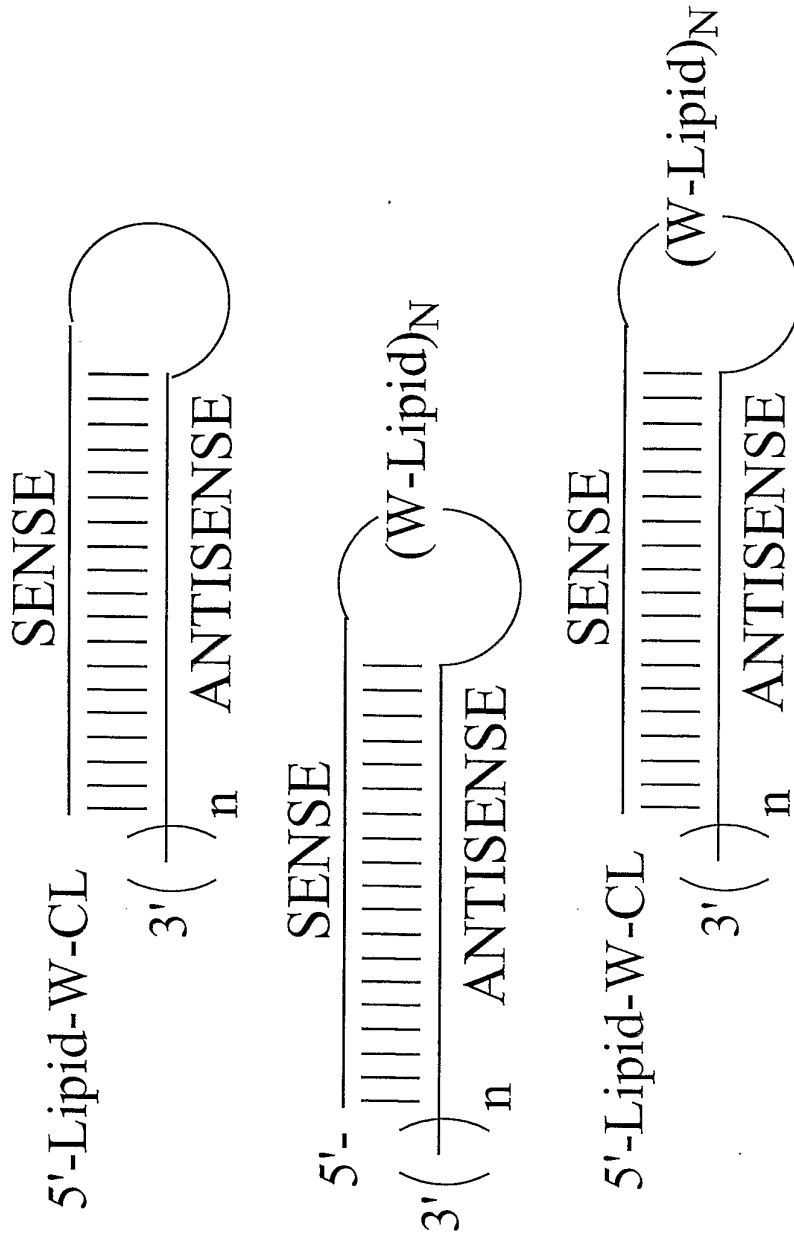


**Figure 61: siNA Lipid Conjugates**



CL=cleavable linker (e.g. A-dT, C-dT) that is optionally present  
 Lipid= Straight chain or branched alkyl or fatty acid, e.g. C<sub>18</sub>H<sub>37</sub>  
 W= linker molecule (see for example Formulae 48, 49, 64, or 65)  
 n = integer, e.g. 1, 2, or 3

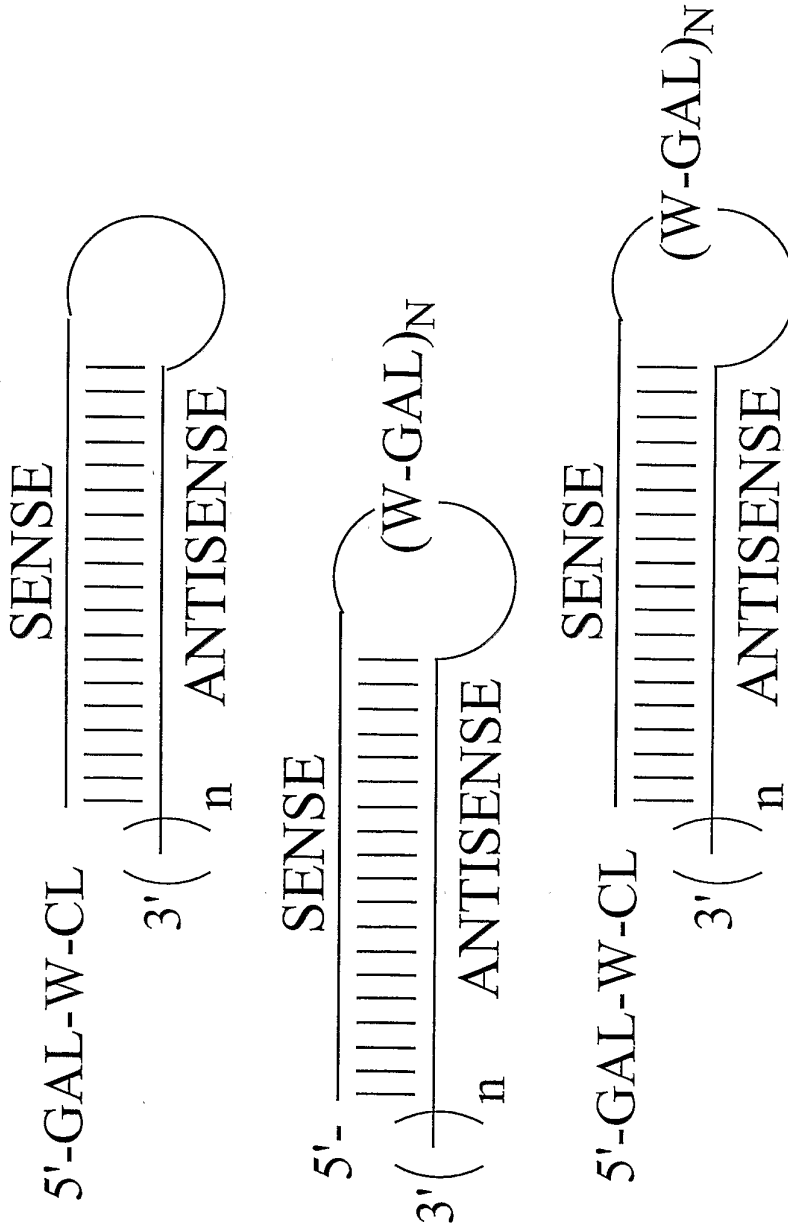
**Figure 62: siNA Lipid Conjugates**



CL=cleavable linker (e.g. A-dT, C-dT) that is optionally present  
 Lipid= Straight chain or branched alkyl or fatty acid, e.g. C<sub>18</sub>H<sub>37</sub>  
 W= linker molecule (see for example Formulae 48, 49, 64, or 65)  
 n = integer, e.g. 1, 2, or 3  
 N=integer, e.g. 1, 2, 3, or 4

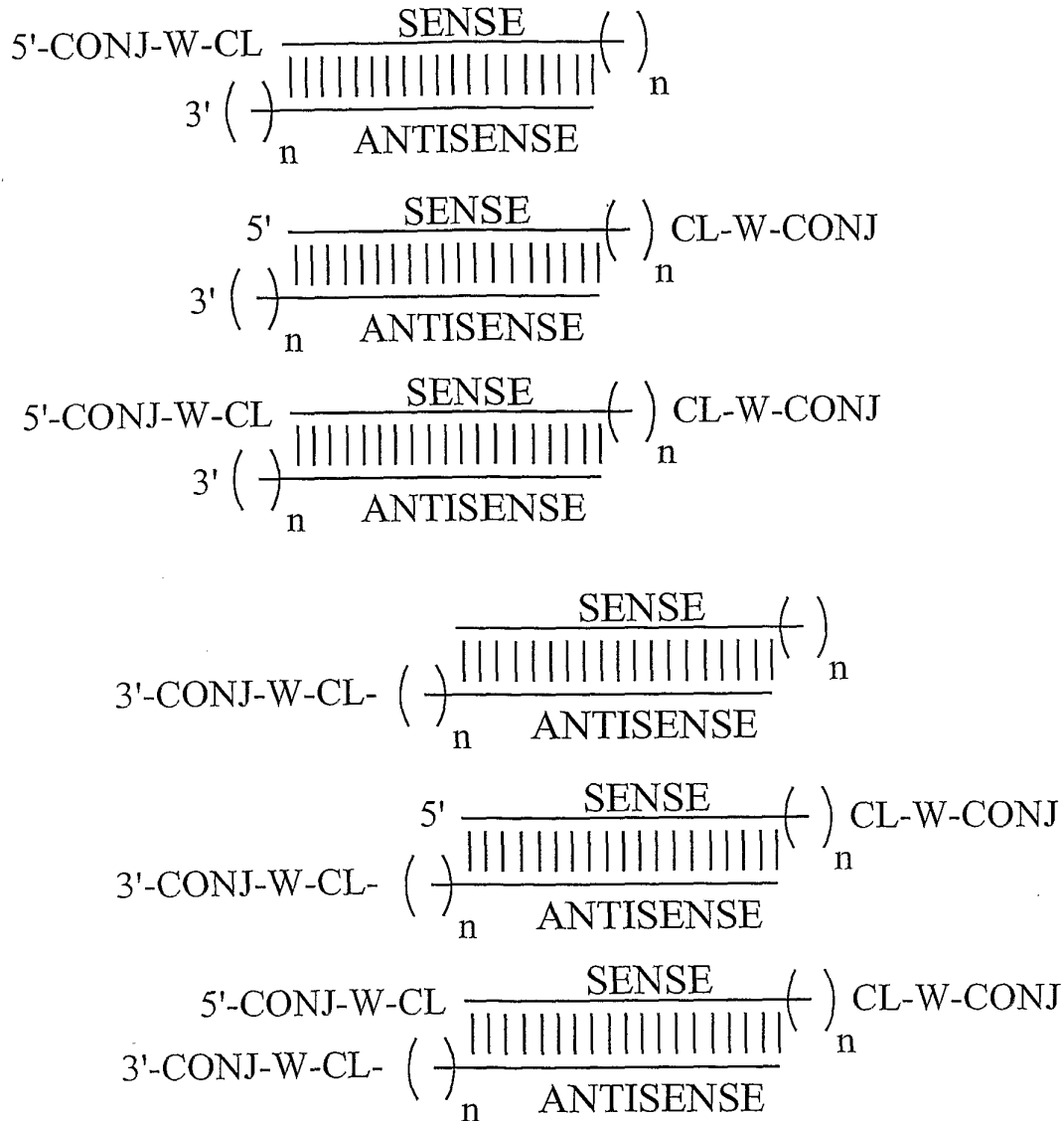


*Figure 64: siNA Galactosamine Conjugates*



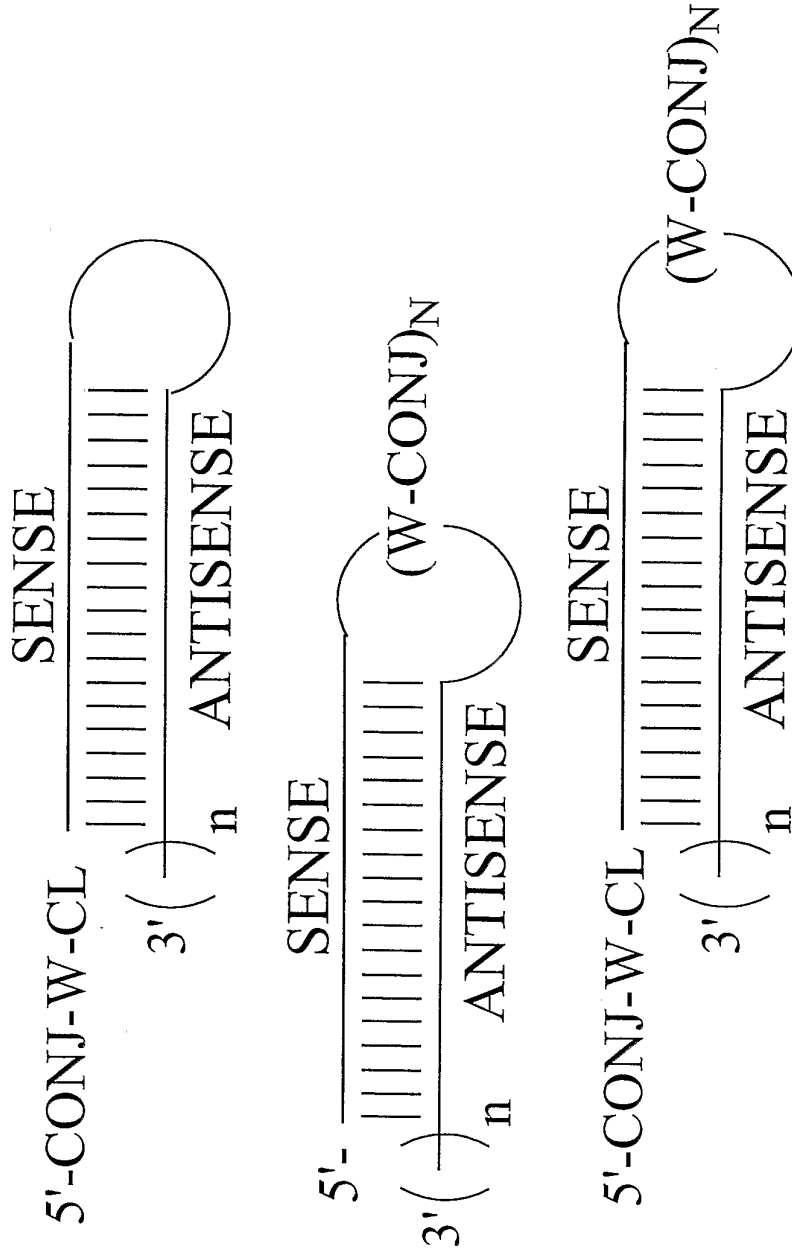
CL=cleavable linker (e.g. A-dT, C-dT) that is optionally present  
 GAL=GALACTOSAMINE; e.g. compounds having Formulae 51-56, 86, 92, 99, 100, 103, 105, 106  
 W= linker molecule (see for example Formulae 102 or 103)  
 n = integer, e.g. 1, 2, or 3  
 N=integer, e.g. 1, 2, 3, or 4

**Figure 65: Generalized siNA Conjugate Design**



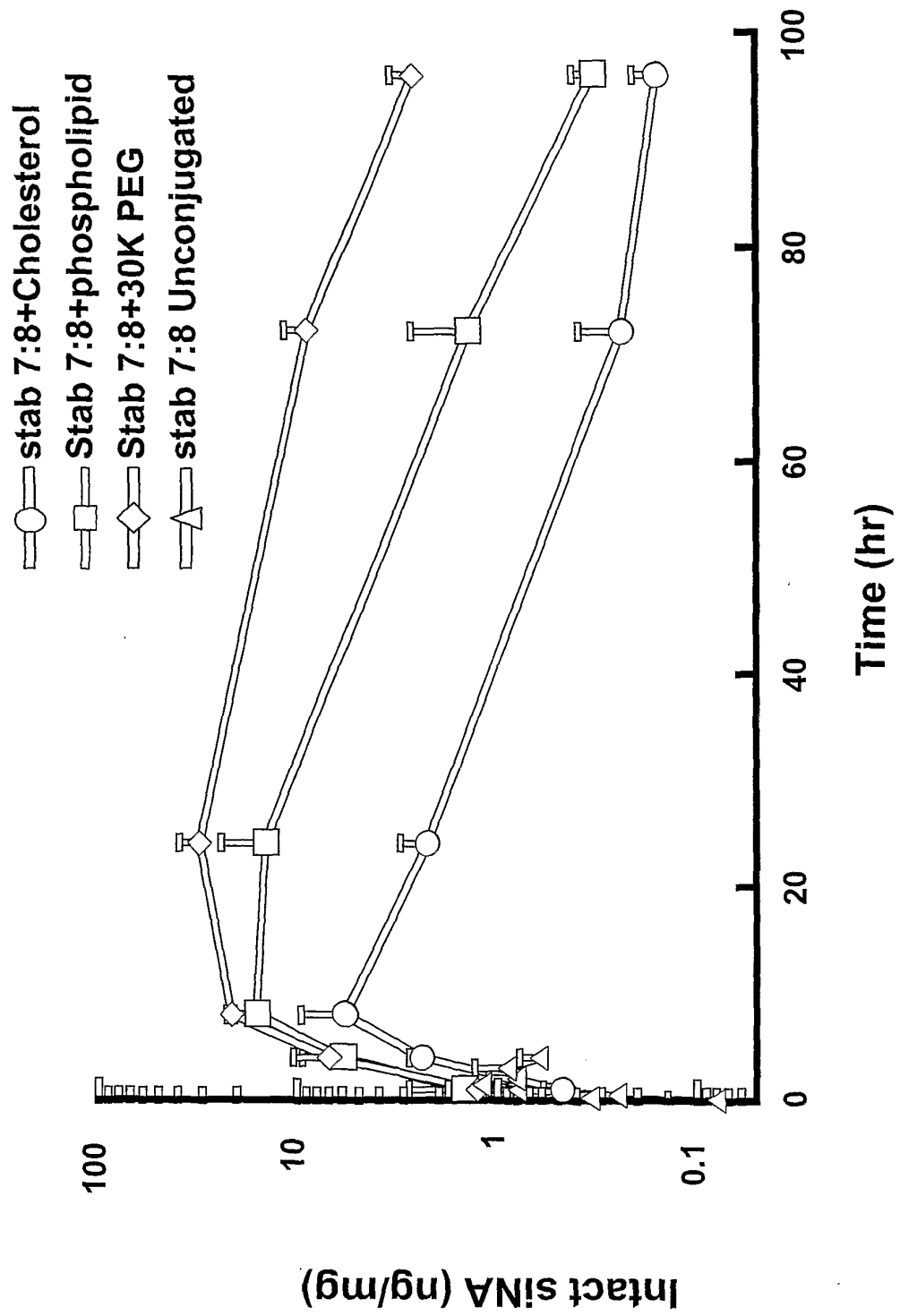
**CONJ**=any biologically active molecule or conjugate as described herein  
**CL**=cleavable linker (e.g. A-dT, C-dT) that is optionally present  
**W**= linker molecule  
**n** = integer, e.g. 1, 2, or 3

**Figure 66: Generalized siNA Conjugate design**

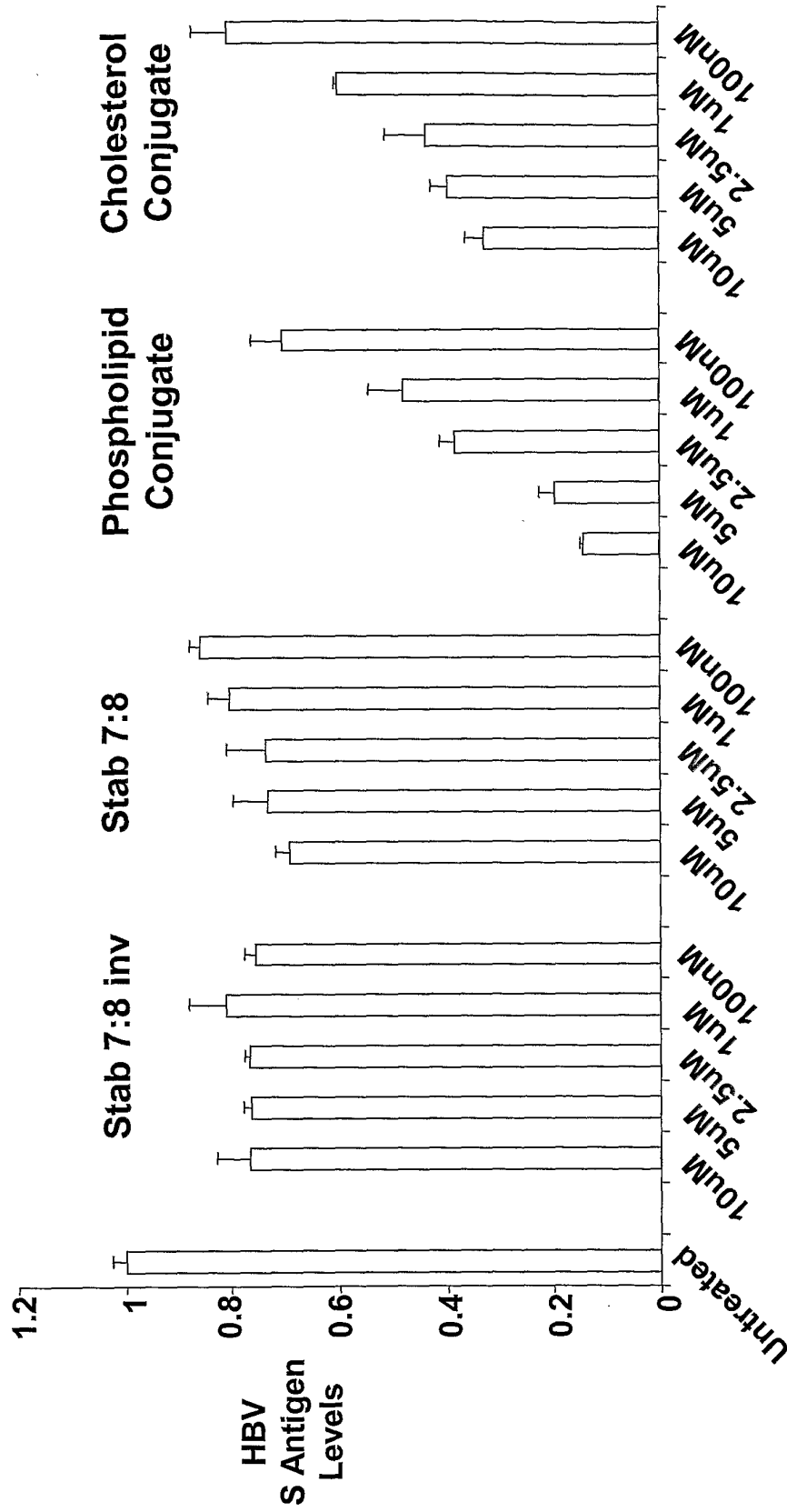


CONJ=any biologically active molecule or conjugate as described herein  
 CL=cleavable linker (e.g. A-dT, C-dT) that is optionally present  
 W= linker molecule  
 n = integer, e.g. 1, 2, or 3  
 N=integer, e.g. 1, 2, 3, or 4

**Figure 67: Distribution of Intact siNA in Liver After SC Administration of Conjugated or Unconjugated Chemistries**

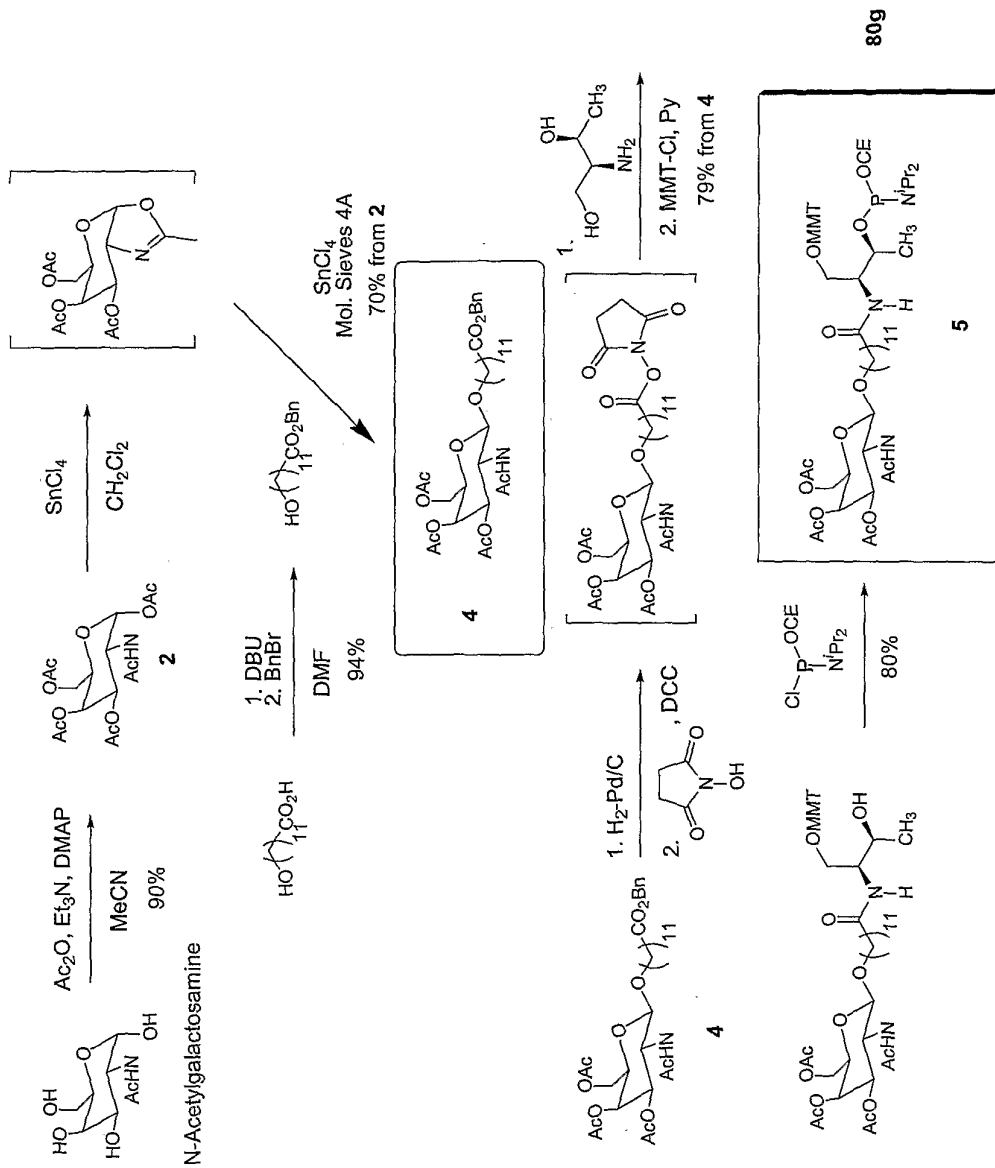


**Figure 68: Lipid Free Delivery of HBV siNA Conjugates in Cell Culture**

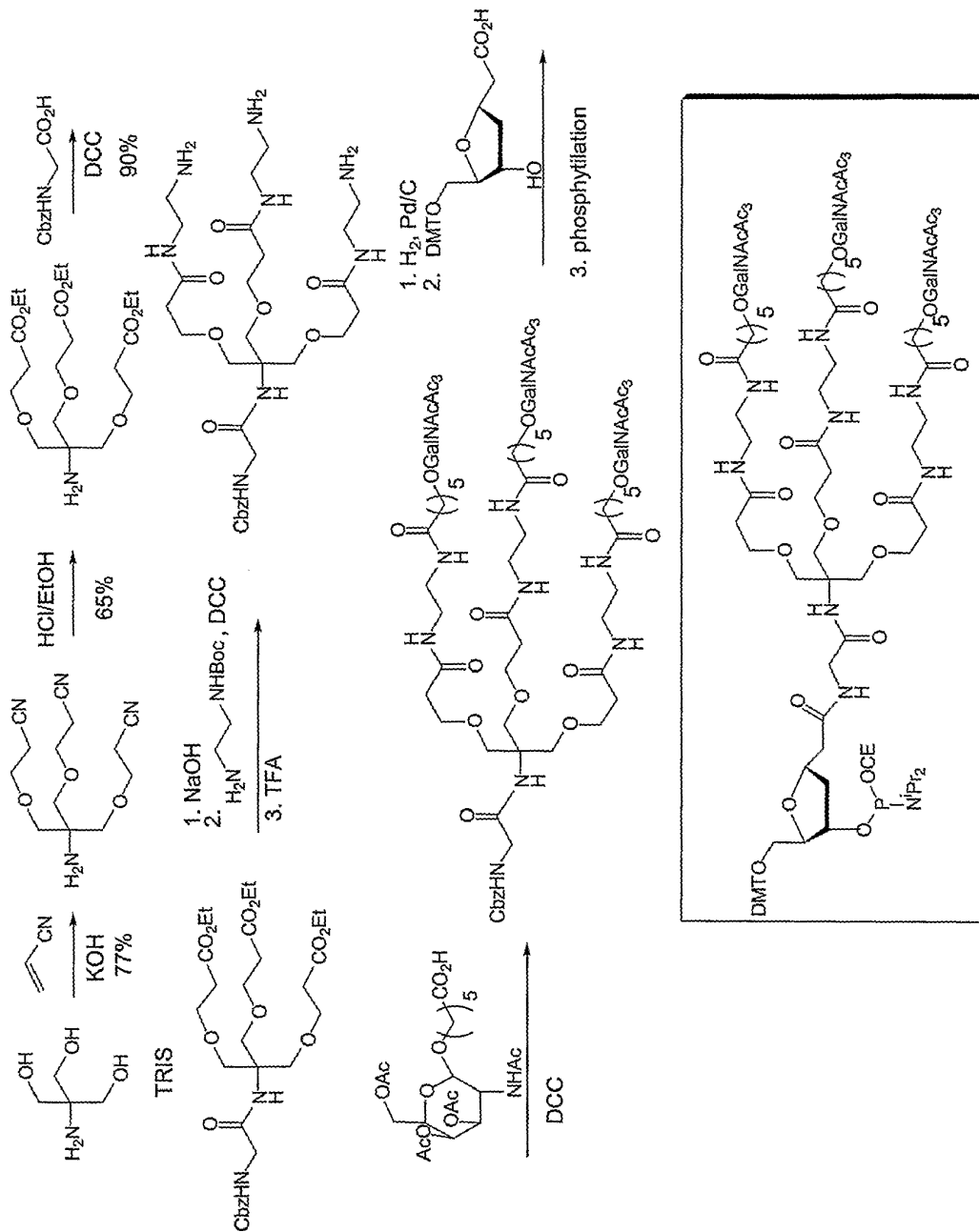




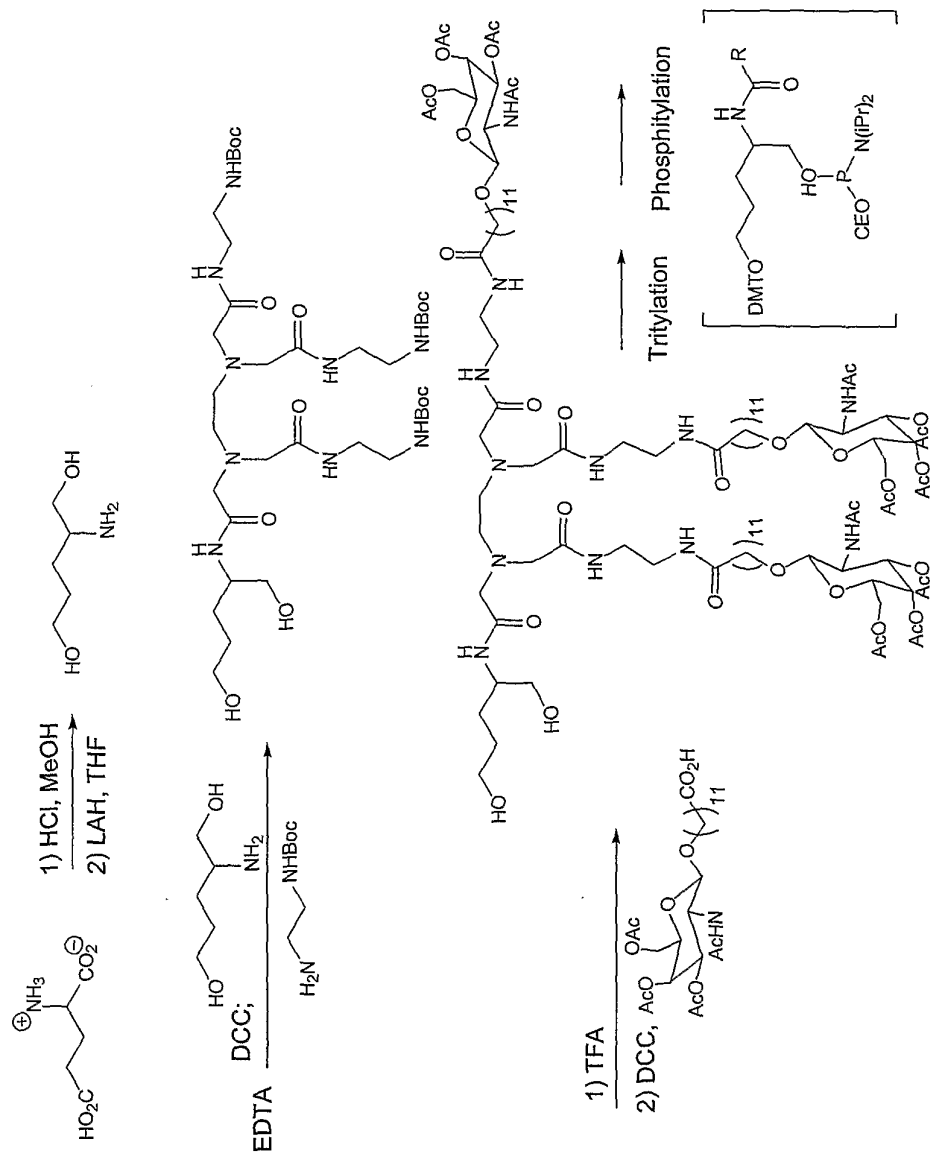
**Figure 69: Scale-up of "mono" Galactosamine phosphoramidite**



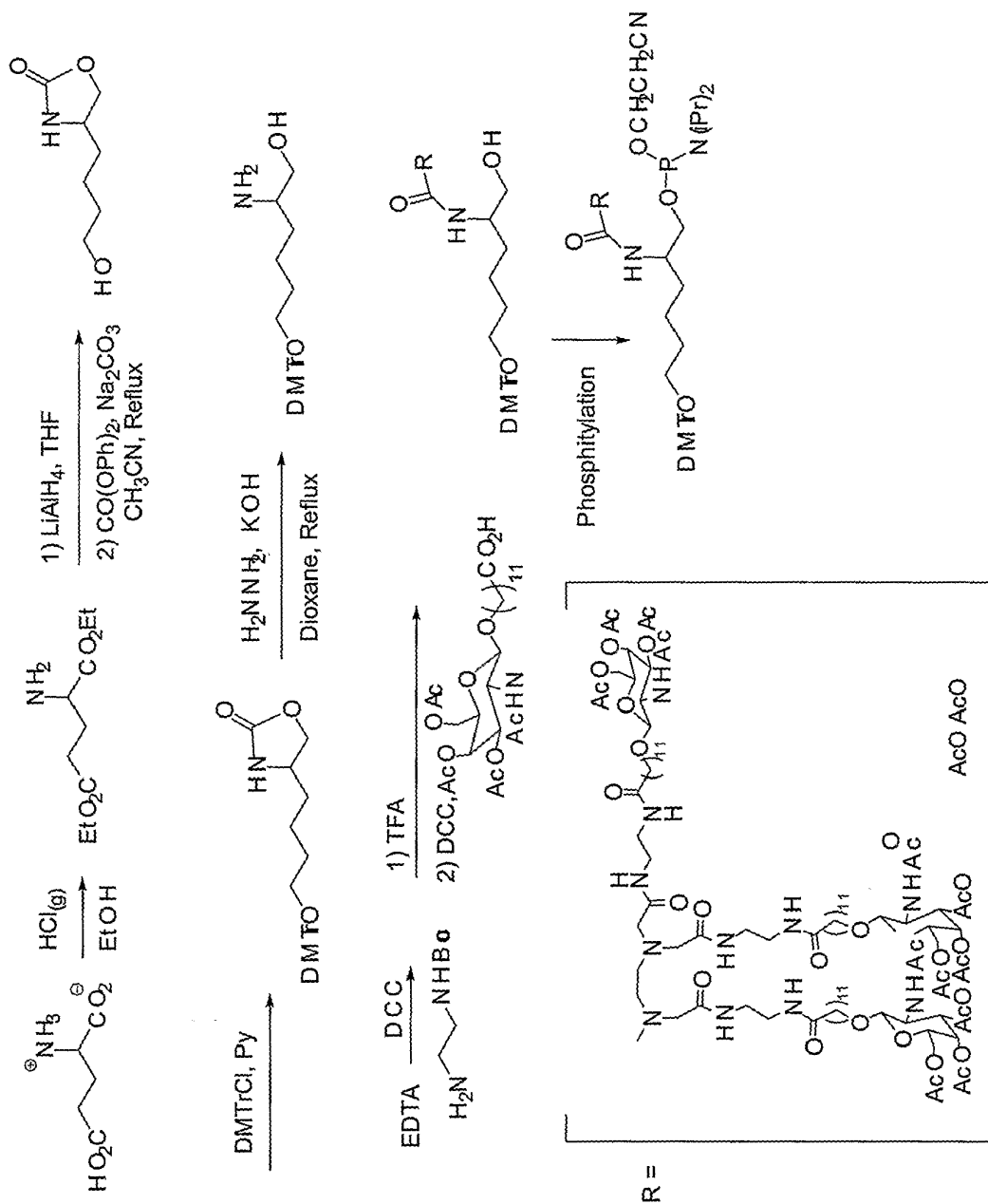
**Figure 70: Synthesis of "tri" Galactosamine phosphoramidite**



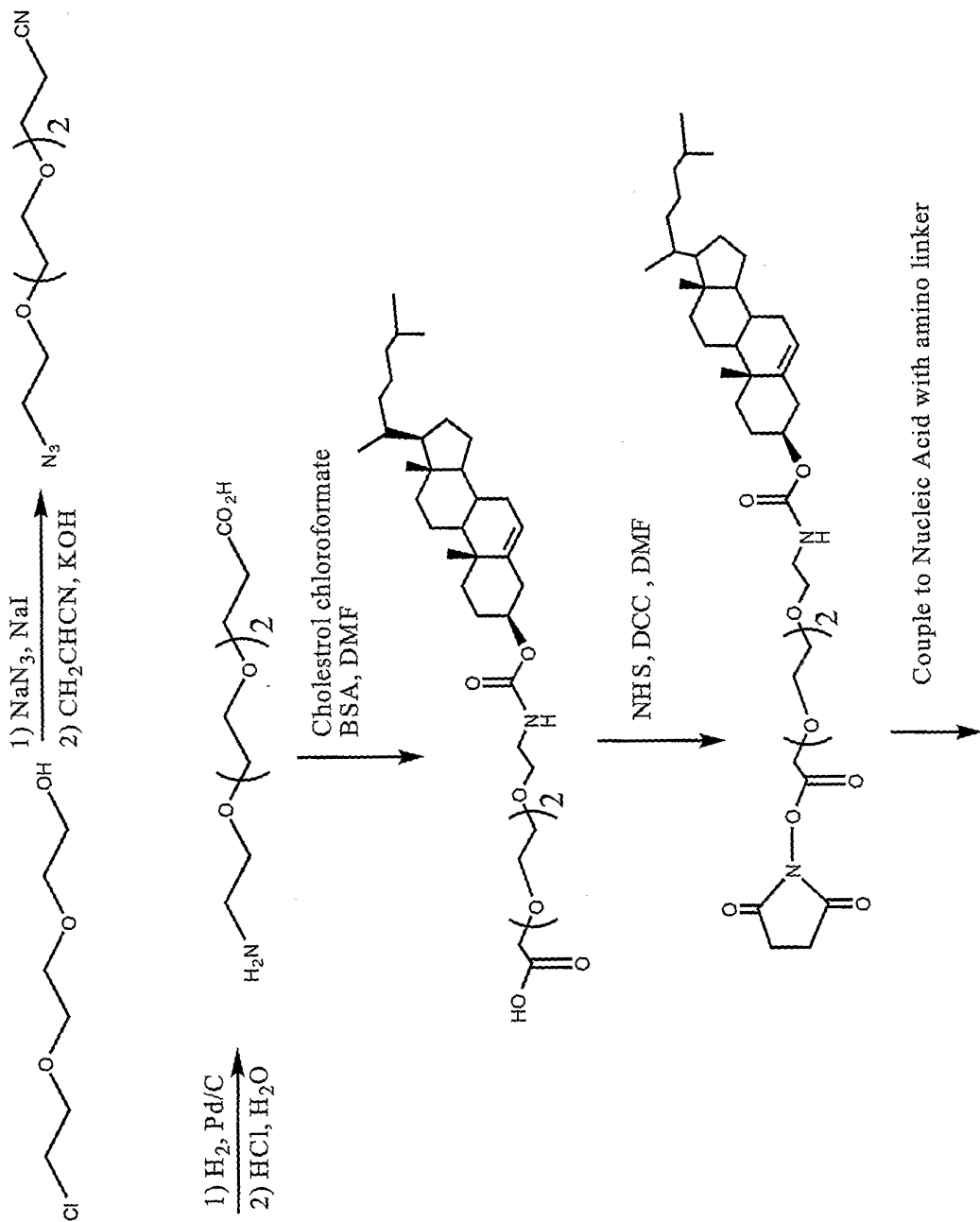
**Figure 71: Synthesis of another Tri-Galactosamine Conjugate**



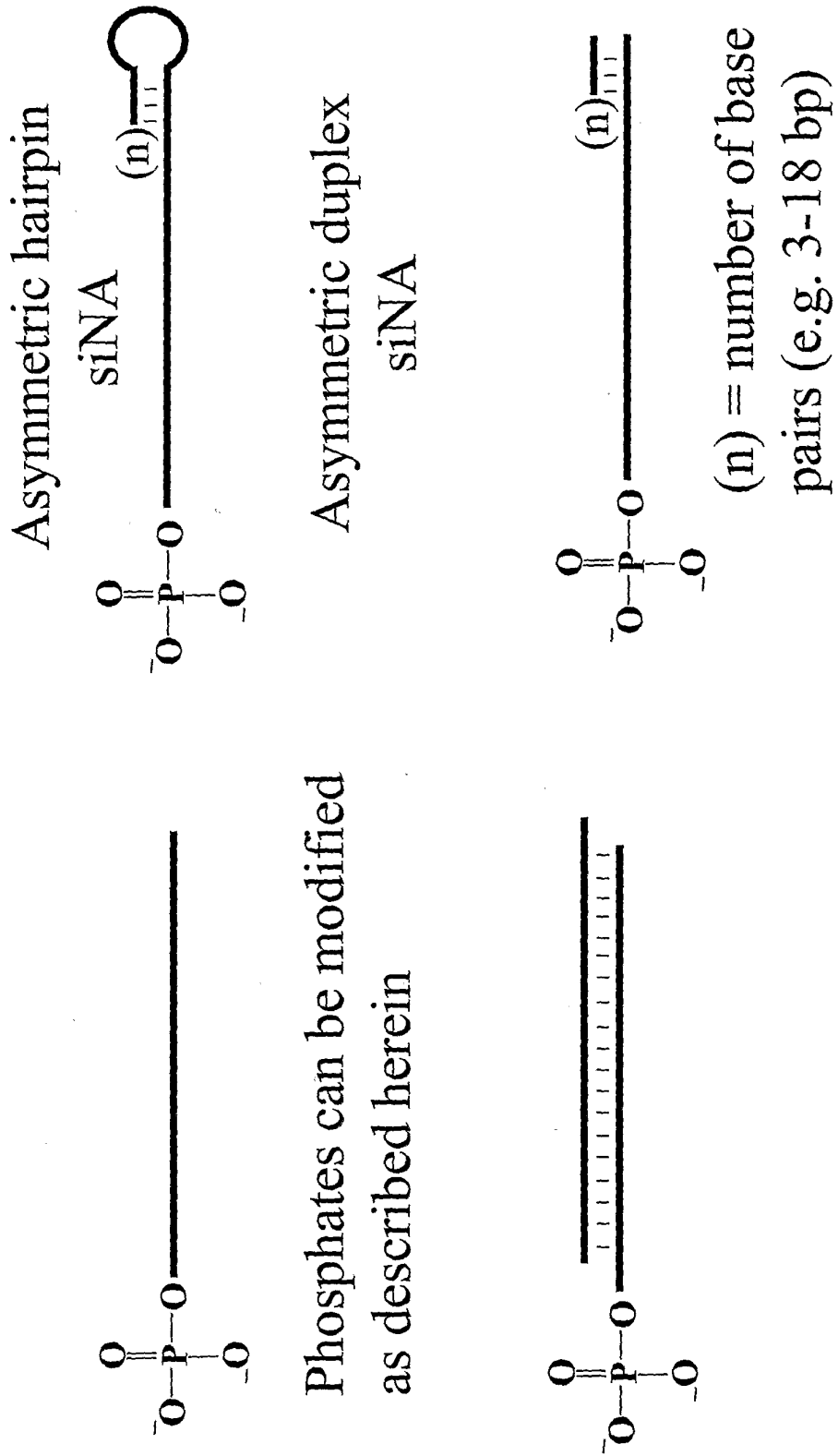
**Figure 72: Alternate Synthesis of Tri-Galactosamine Conjugate**



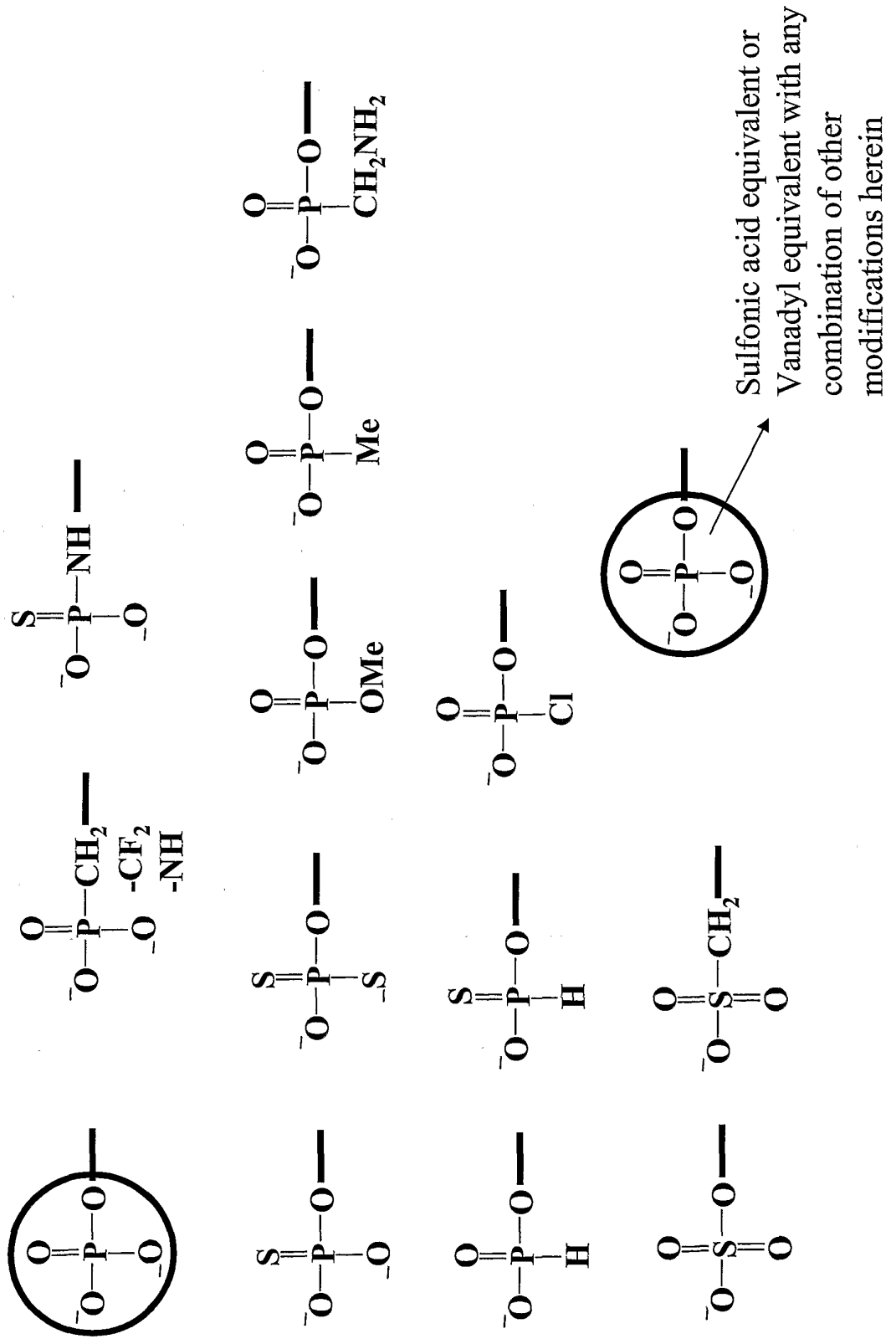
**Figure 73: Synthesis of NHS Cholesterol Conjugate**



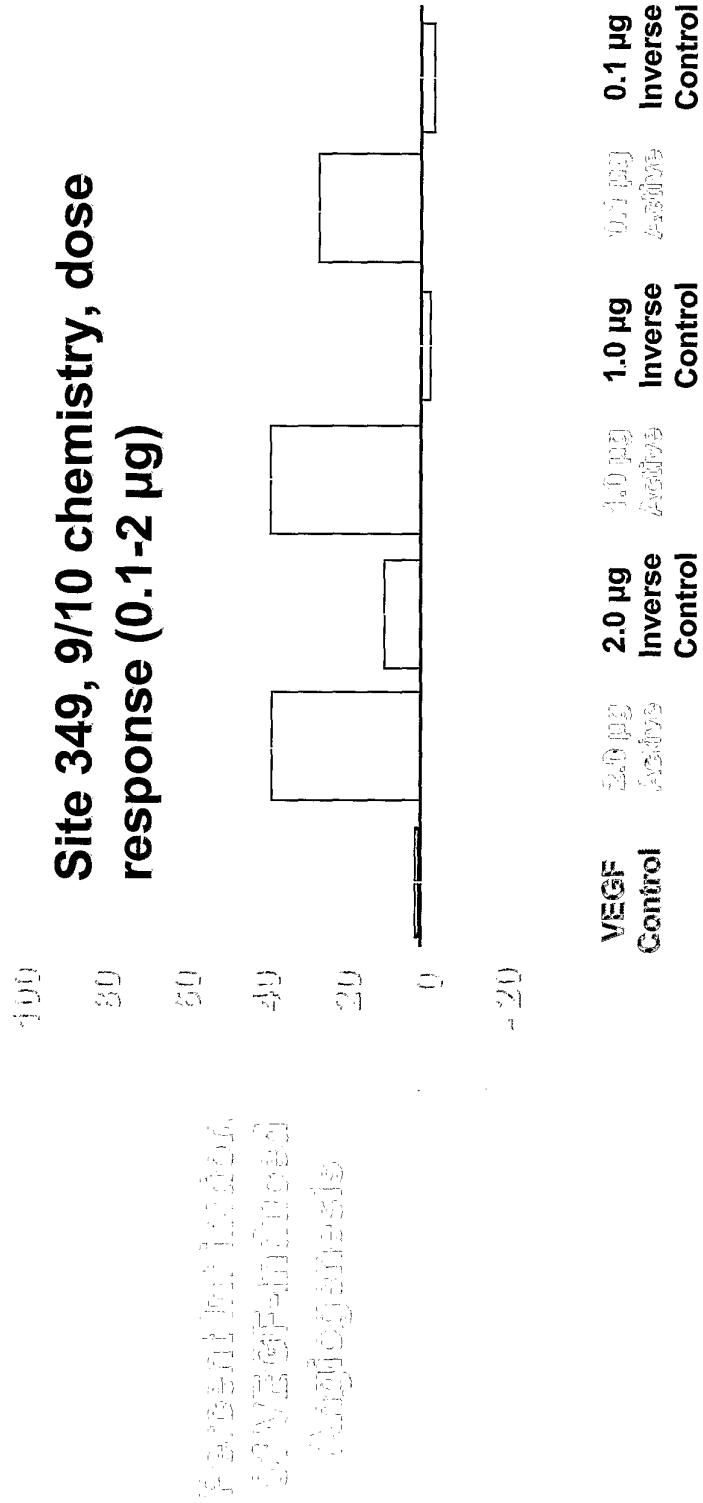
**Figure 74: Phosphorylated siNA constructs**



*Figure 75: 5'-phosphate modifications*



# Figure 76: siNA Targeting VEGFR-1 Inhibits VEGF-Induced Rat Corneal Angiogenesis

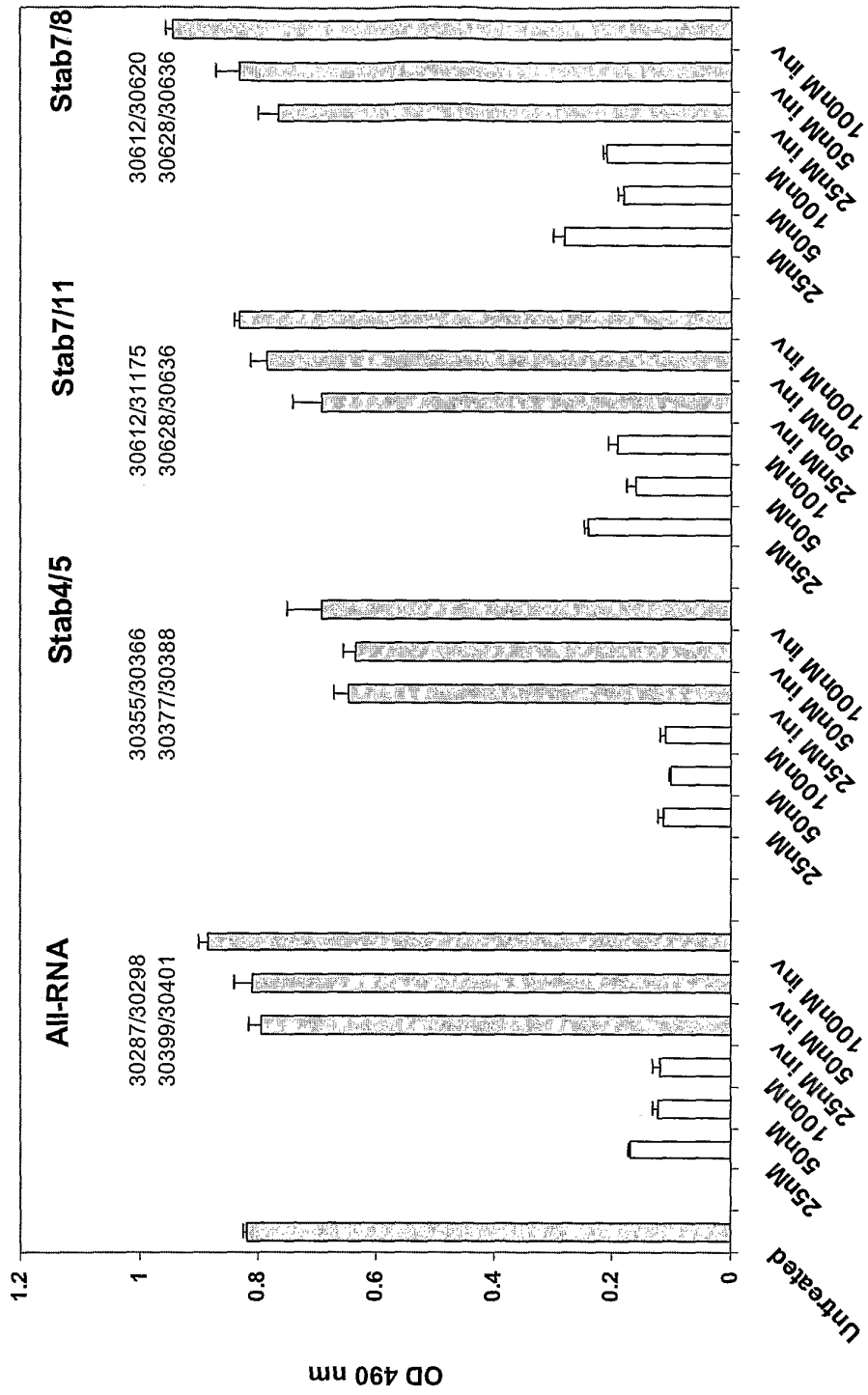




**Figure 77: Duration of Effect of Modified siNA Constructs**

HBV siRNA Duration: Day 3

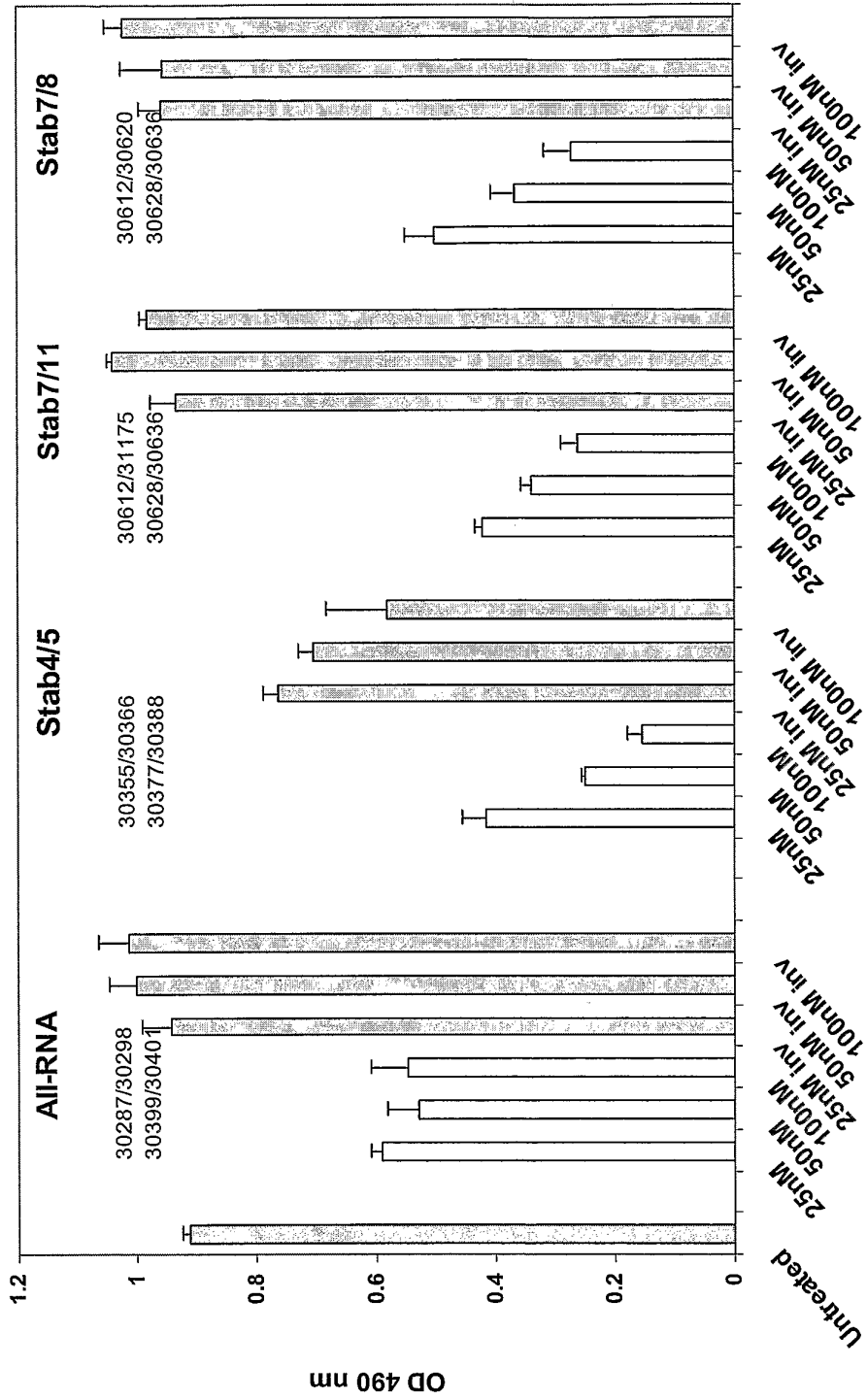
**A**



**Figure 77: Duration of Effect of Modified siNA Constructs**

HBV siRNA Duration: Day 9

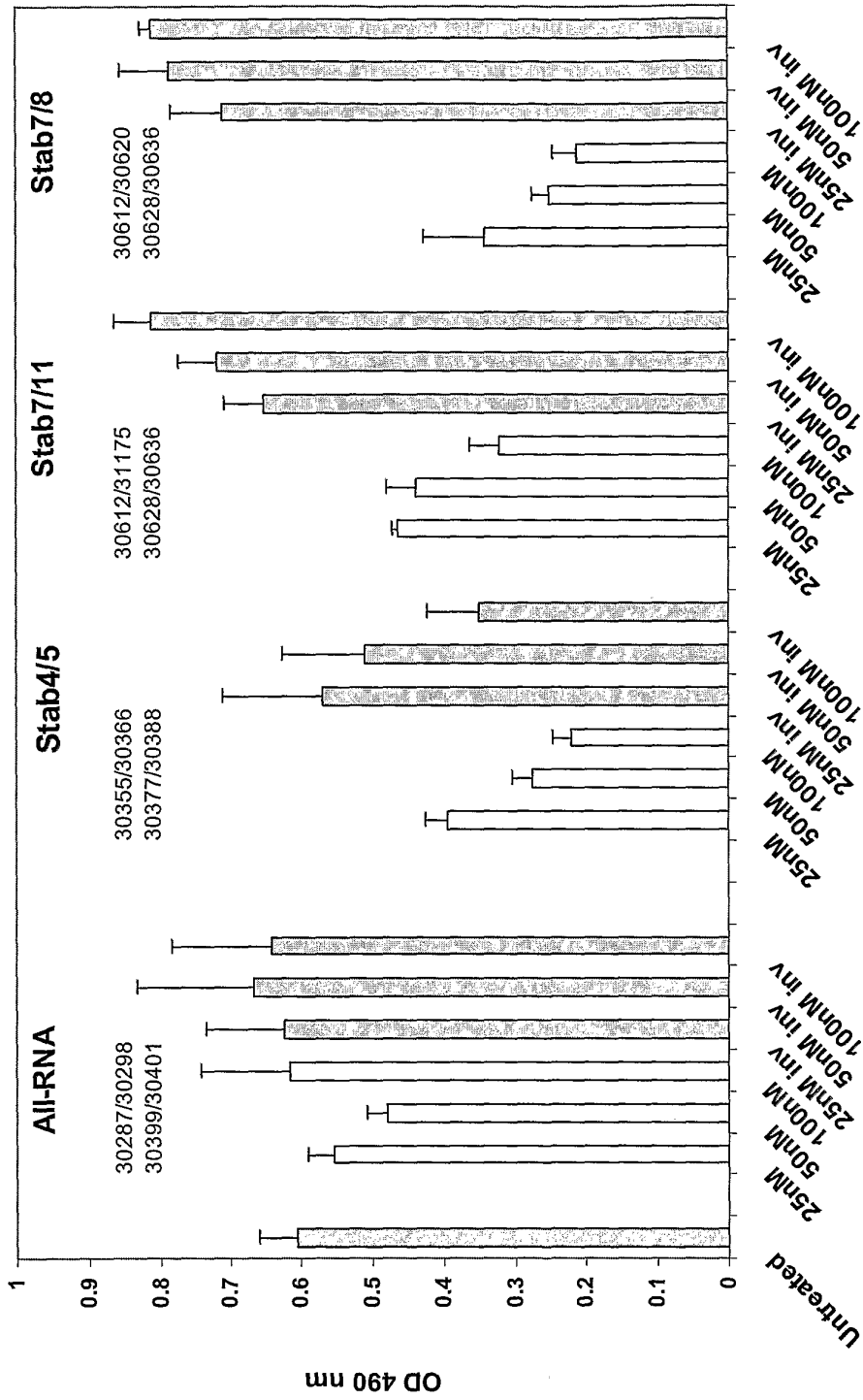
**B**



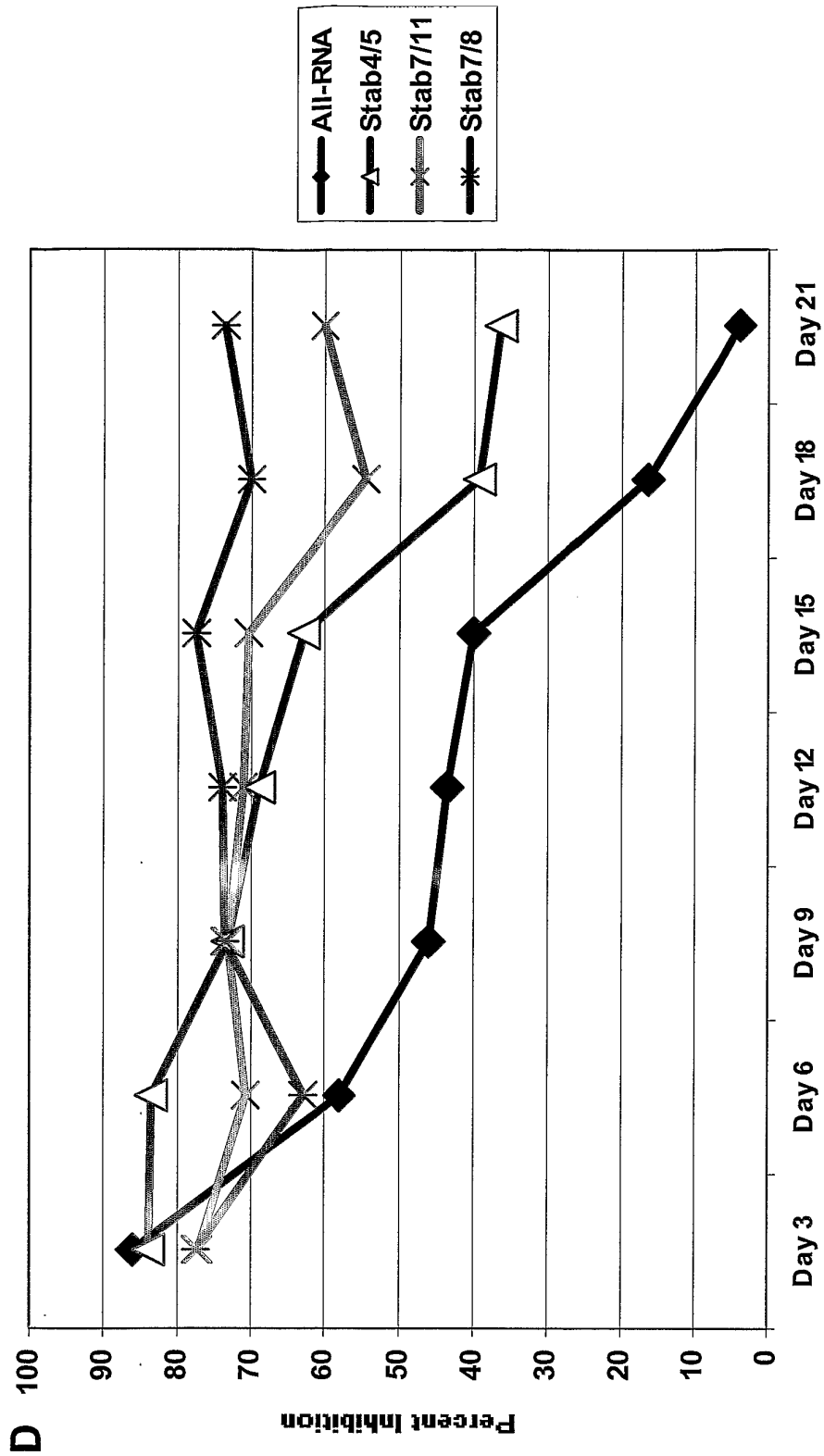
**Figure 77: Duration of Effect of Modified siNA Constructs**

HBV siRNA Duration: Day 21

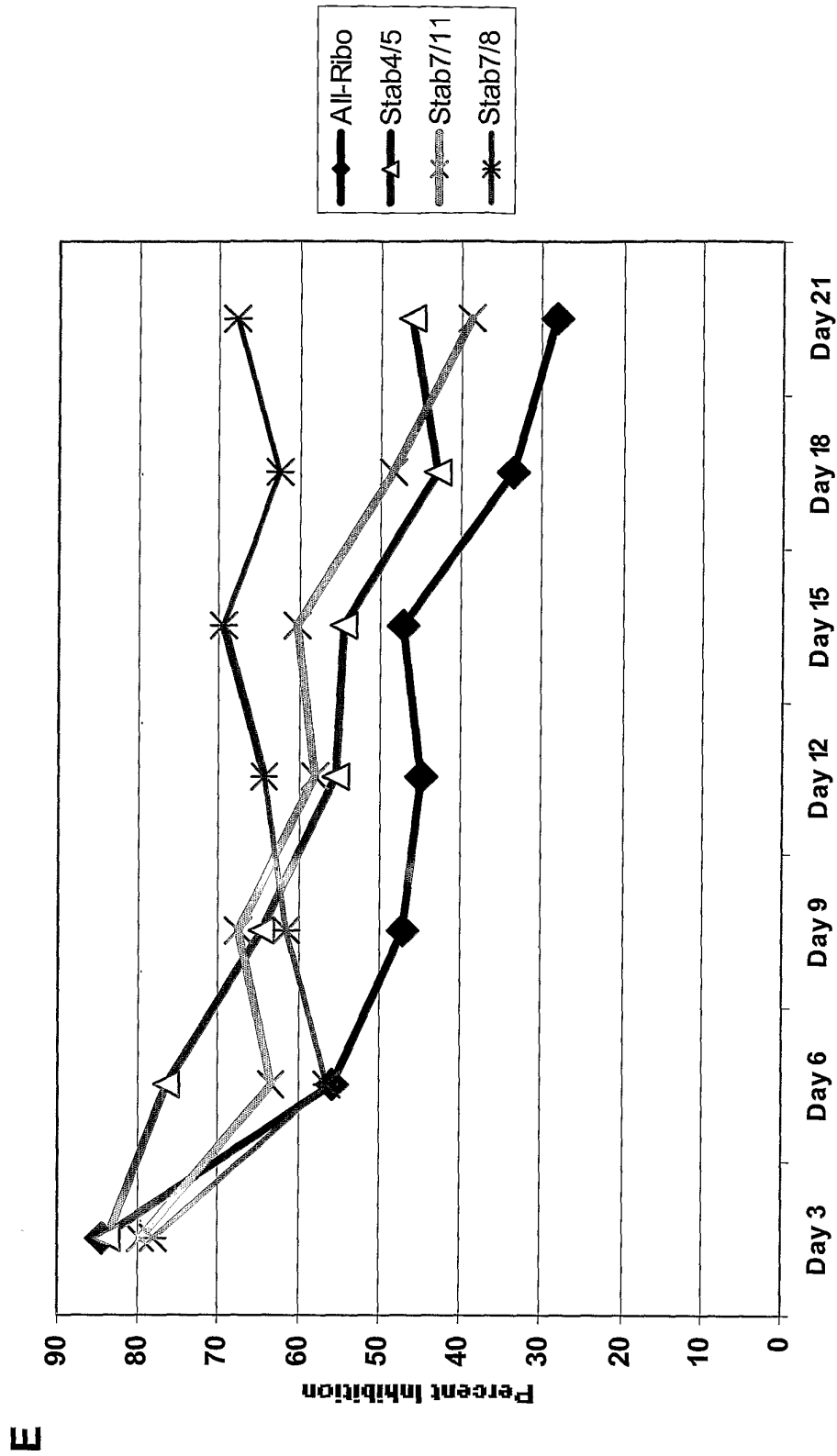
C



**Figure 77: Duration of Effect of Modified siNA Constructs**

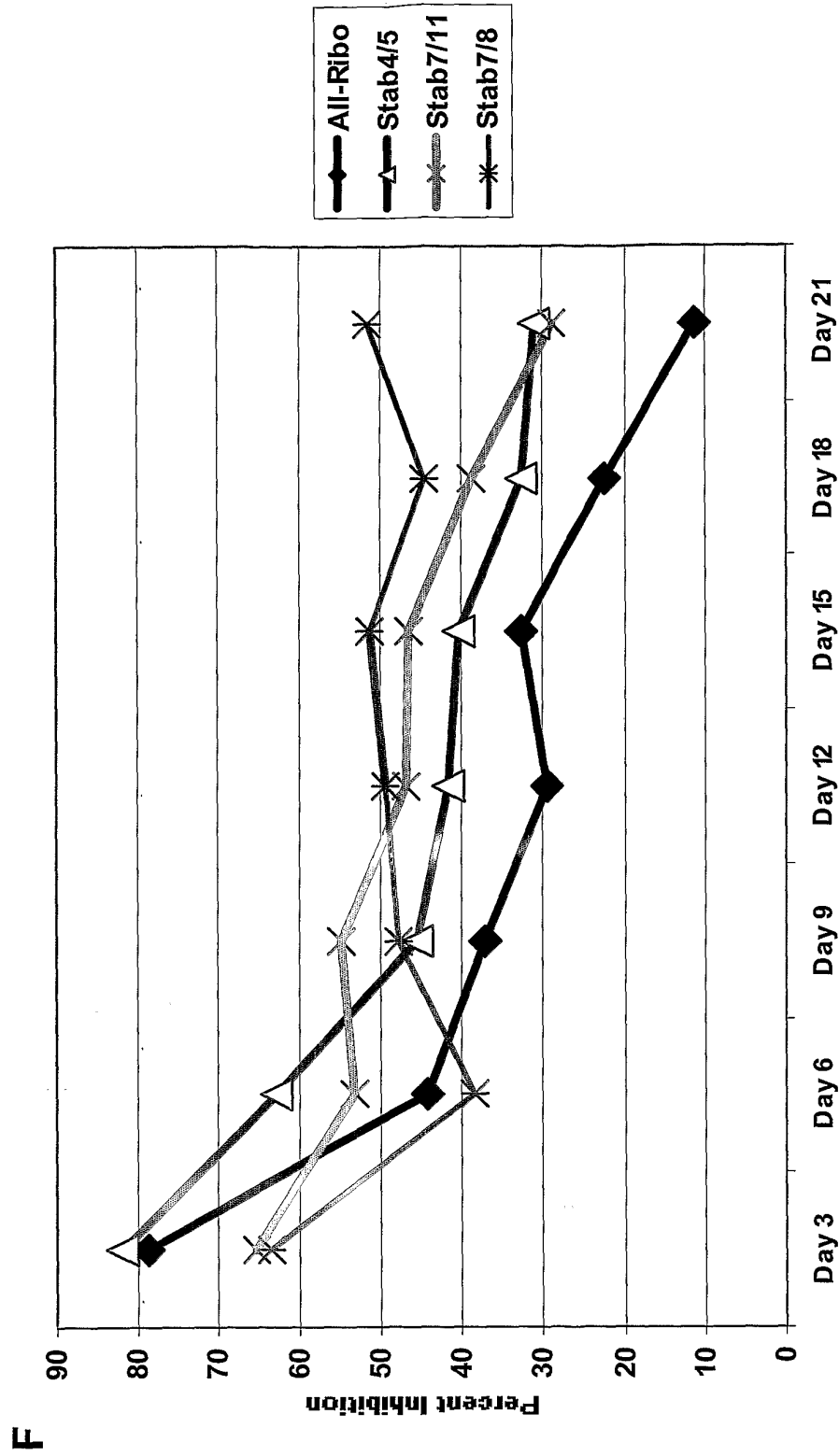


**Figure 77: Duration of Effect of Modified siNA Constructs**



E

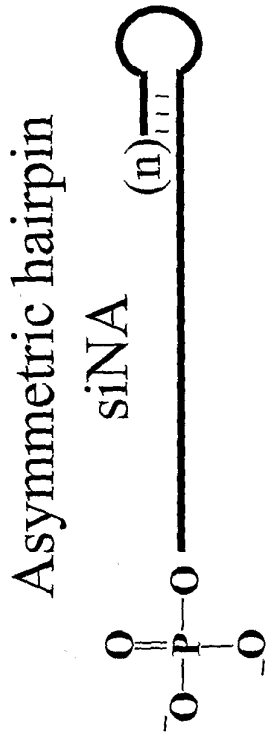
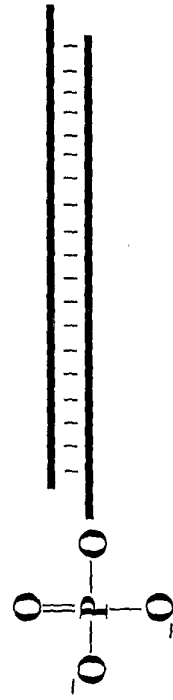
**Figure 77: Duration of Effect of Modified siNA Constructs**



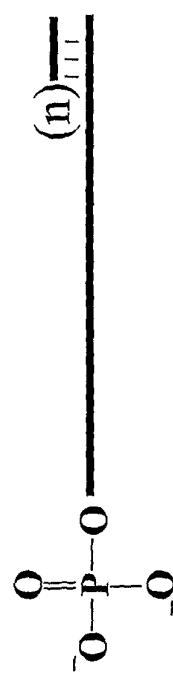
**Figure 78: Phosphorylated siNA constructs**



Phosphates can be modified  
as described herein

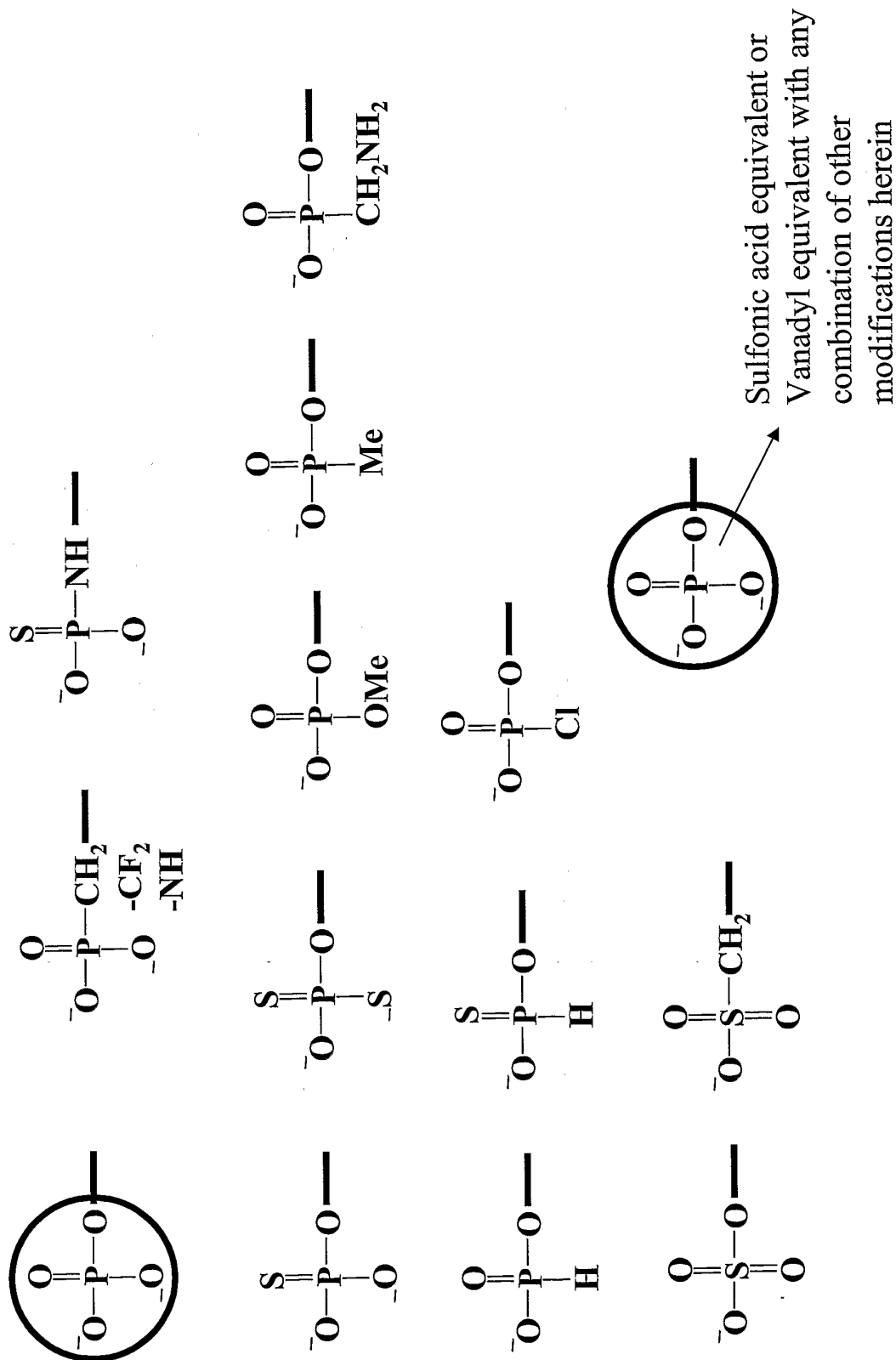


Asymmetric duplex  
siNA

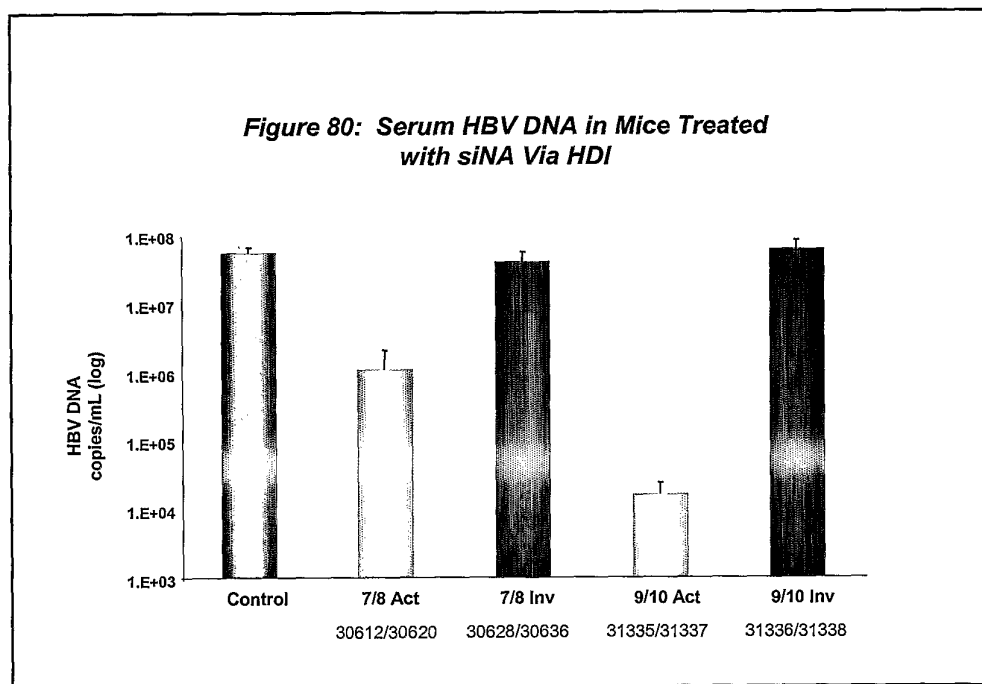


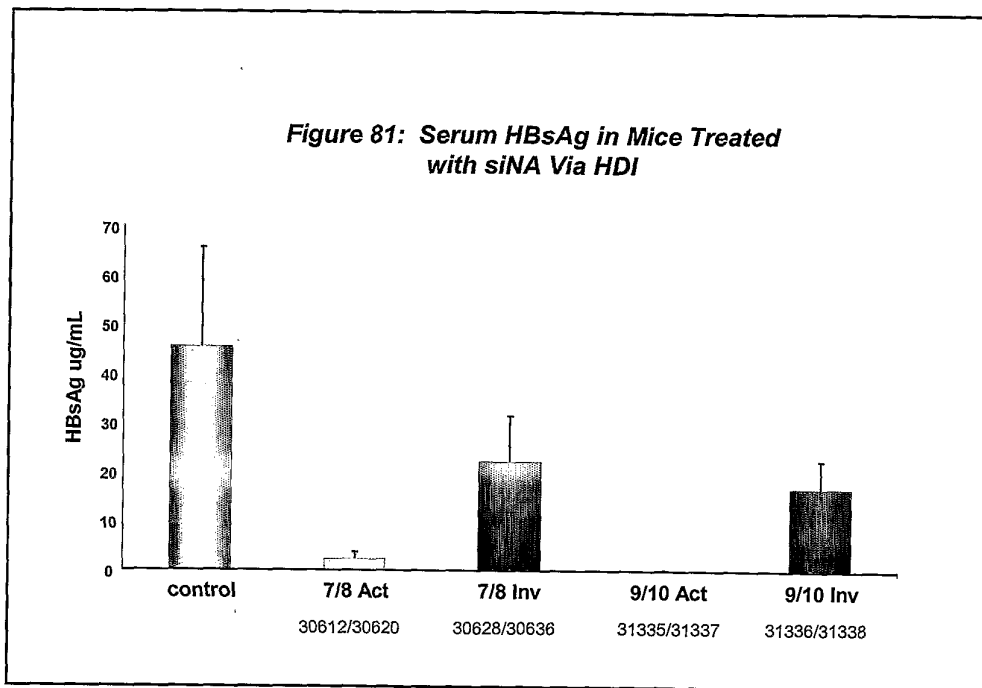
(n) = number of base  
pairs (e.g. 3-18 bp)

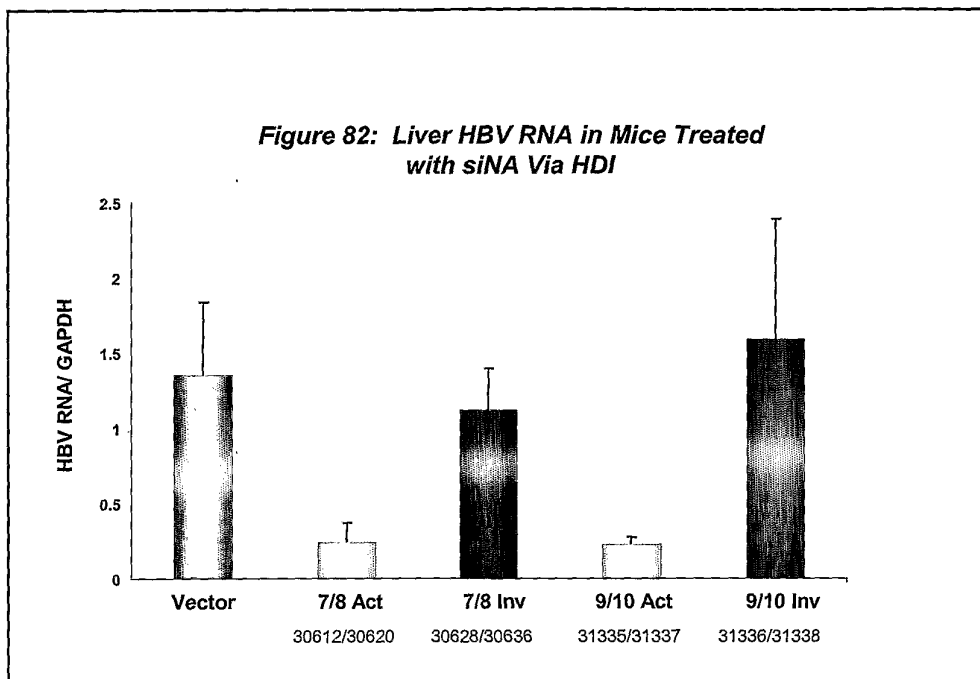
*Figure 79: 5'-phosphate modifications*

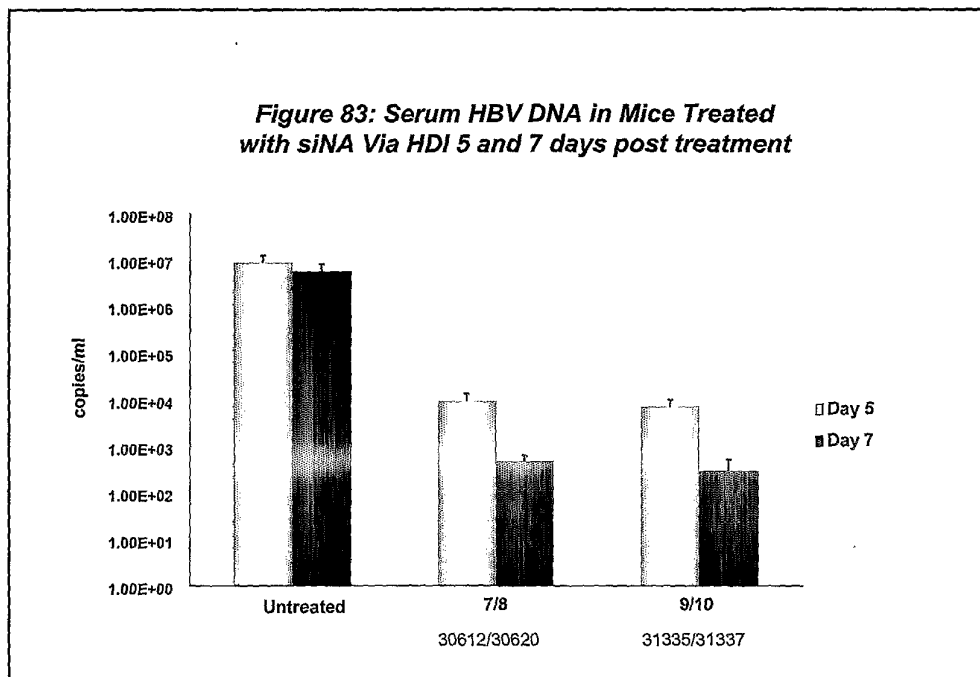


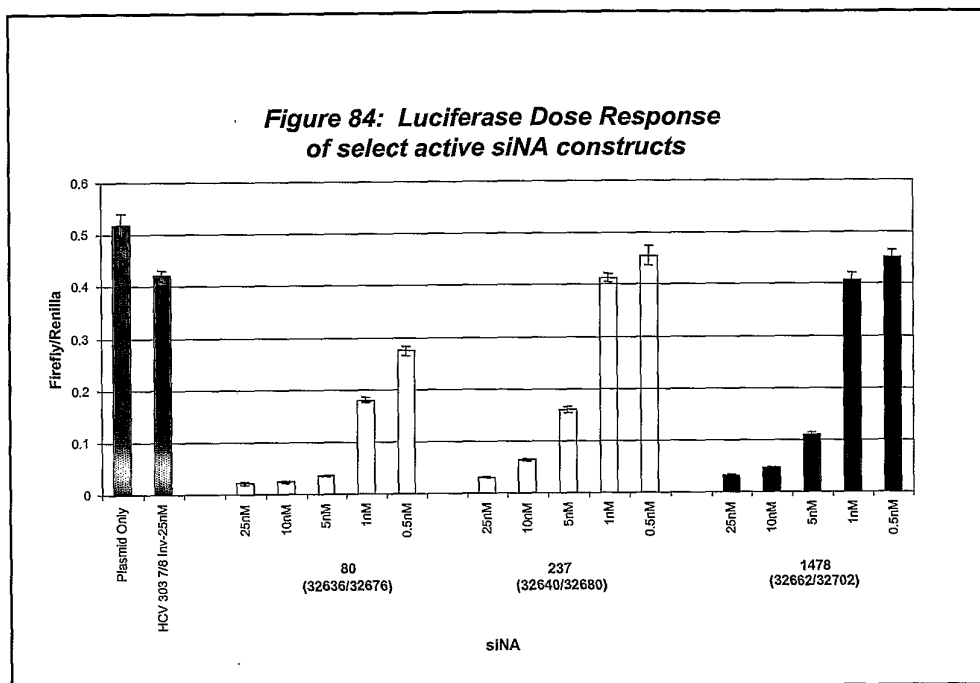


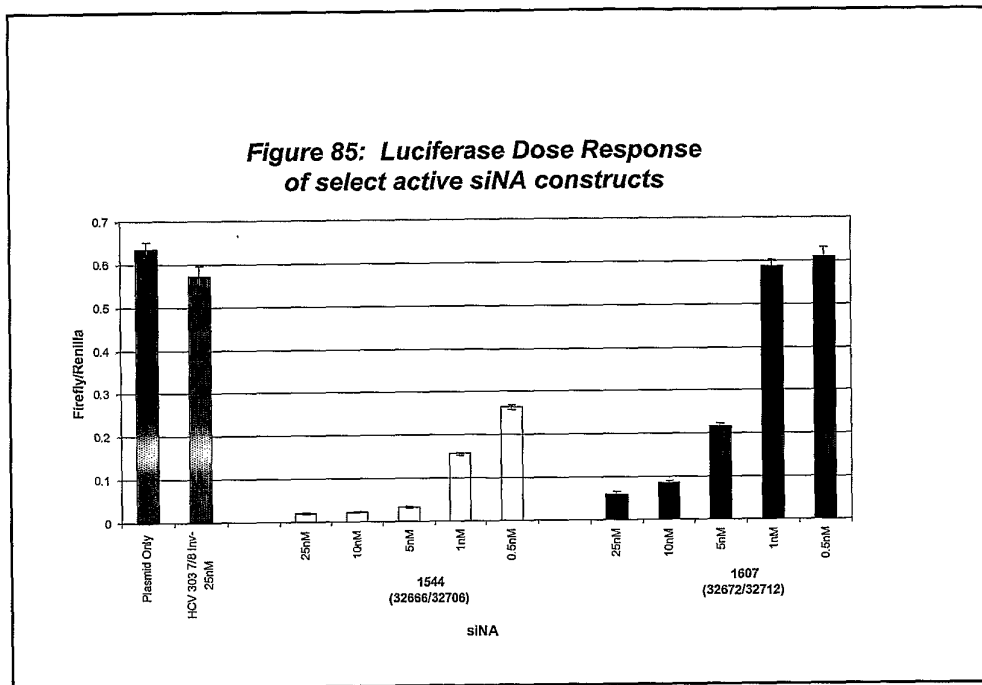




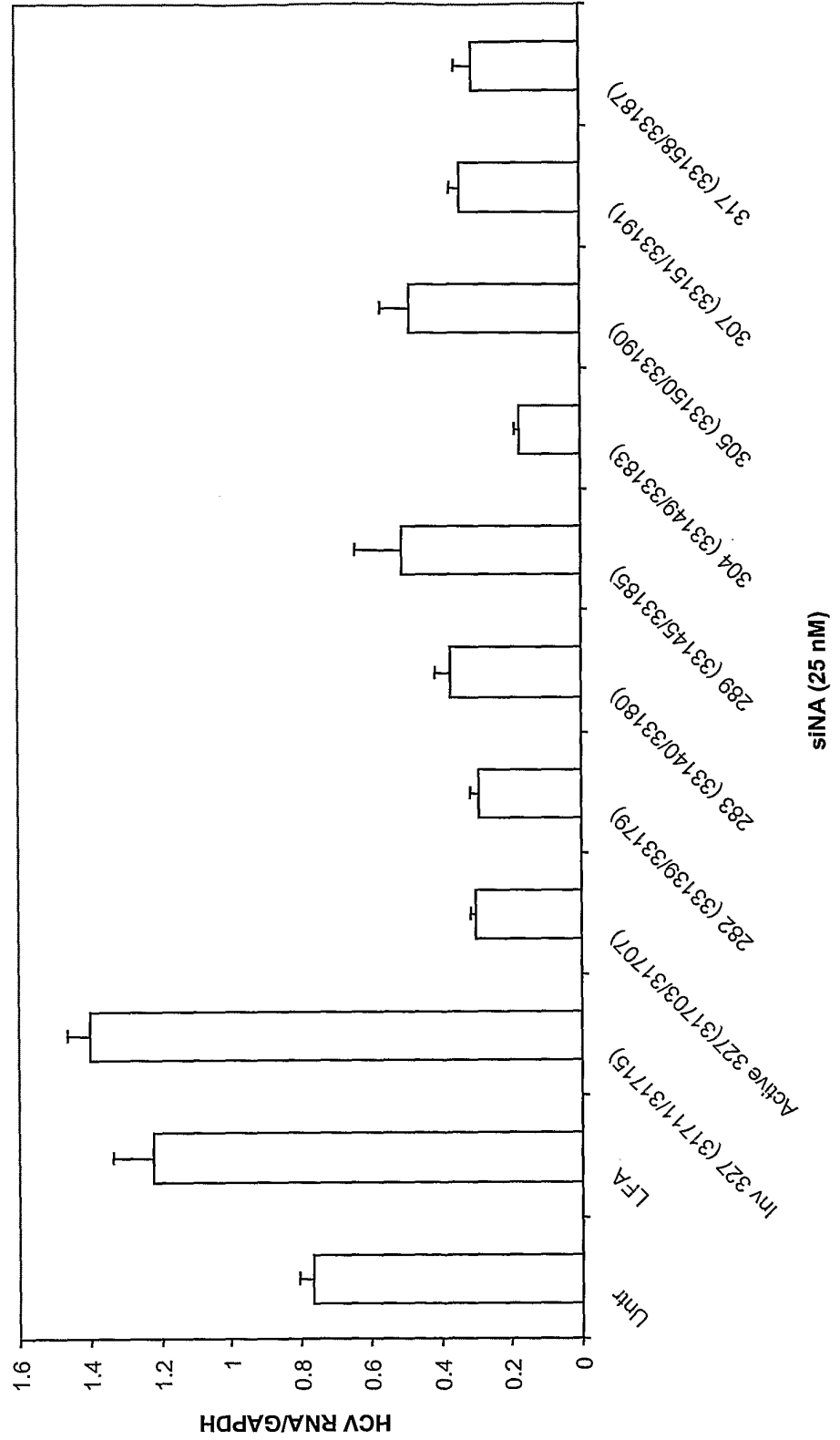








**Figure 86: Activity of Stab 7/8 Stabilized siNAs in HCV Replicon**



**Figure 87: Activity of Stabilized 7/8 siNAs Against HBV in HepG2 Cells**

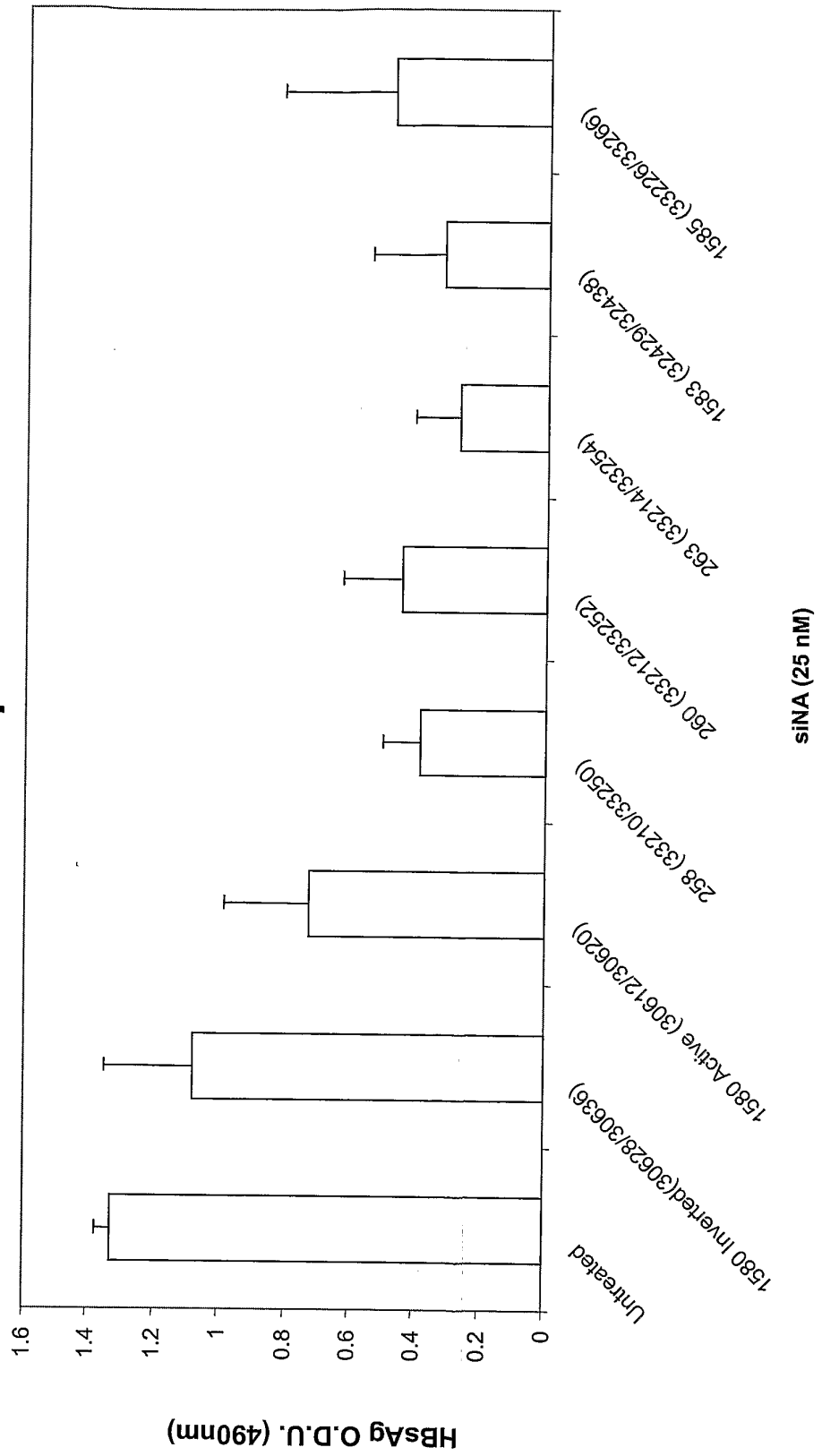
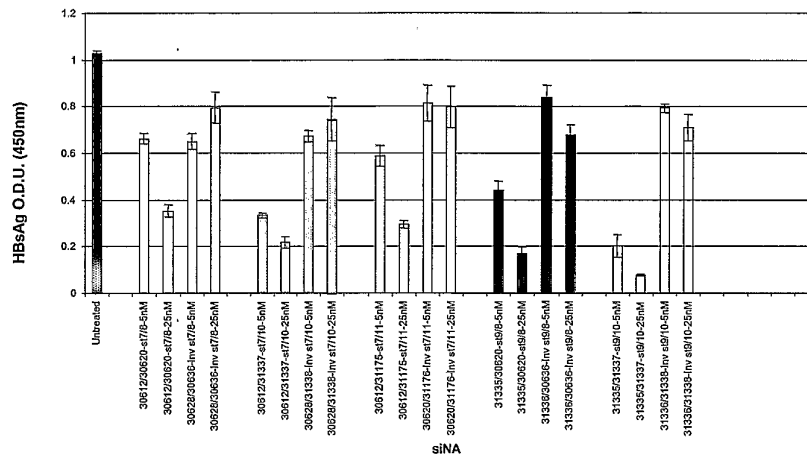
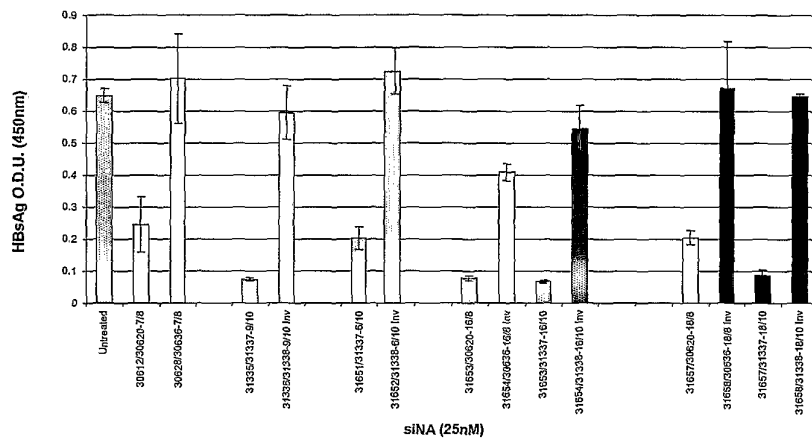




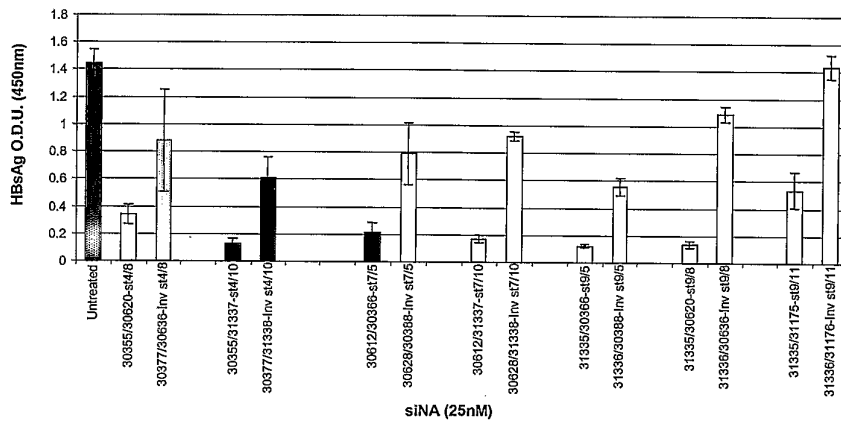
Figure 88: HBV/siNA to site 1580 Combination Constructs



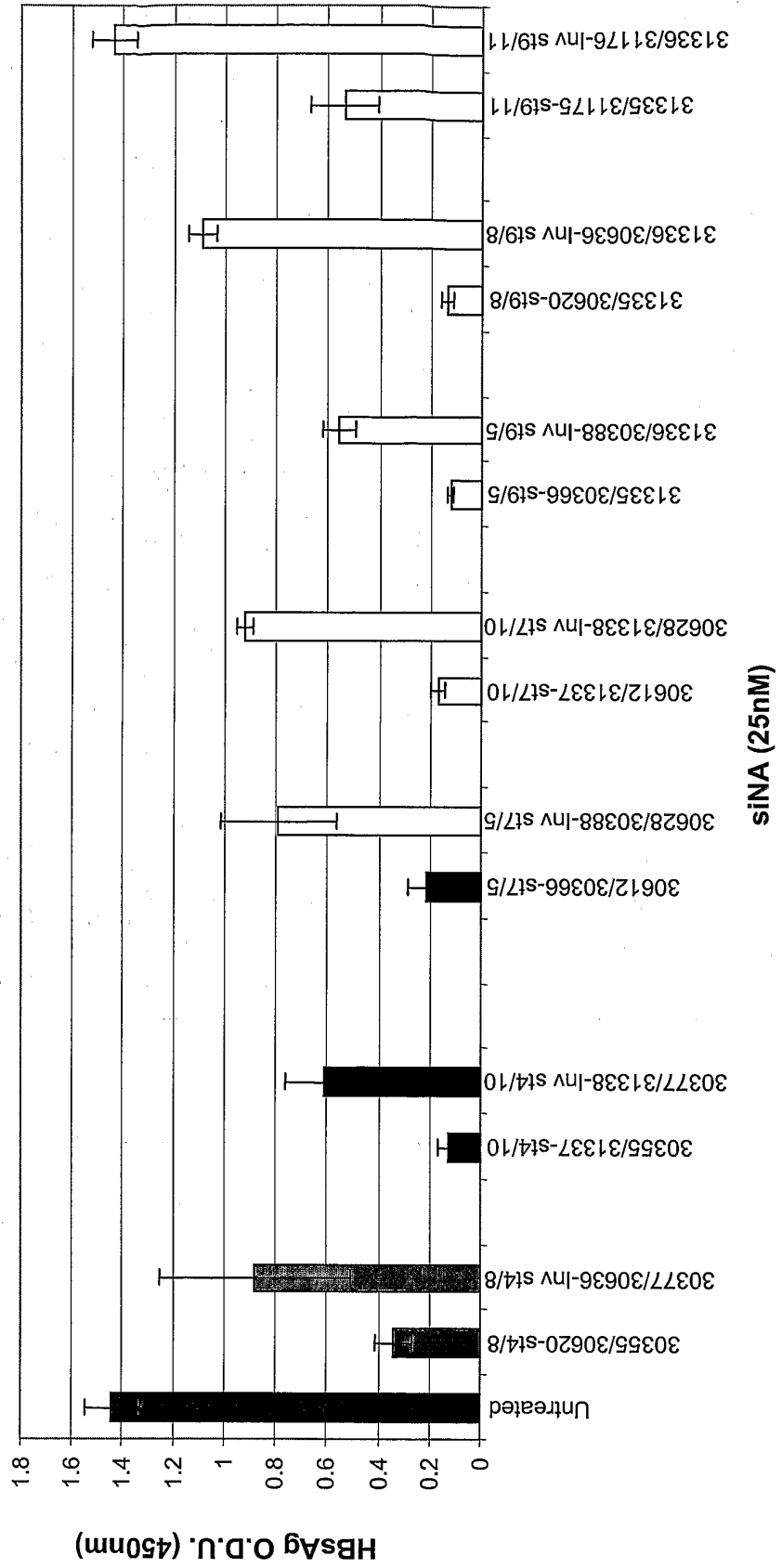
**Figure 89: HBV/siNA to site 1580 Combination Constructs**



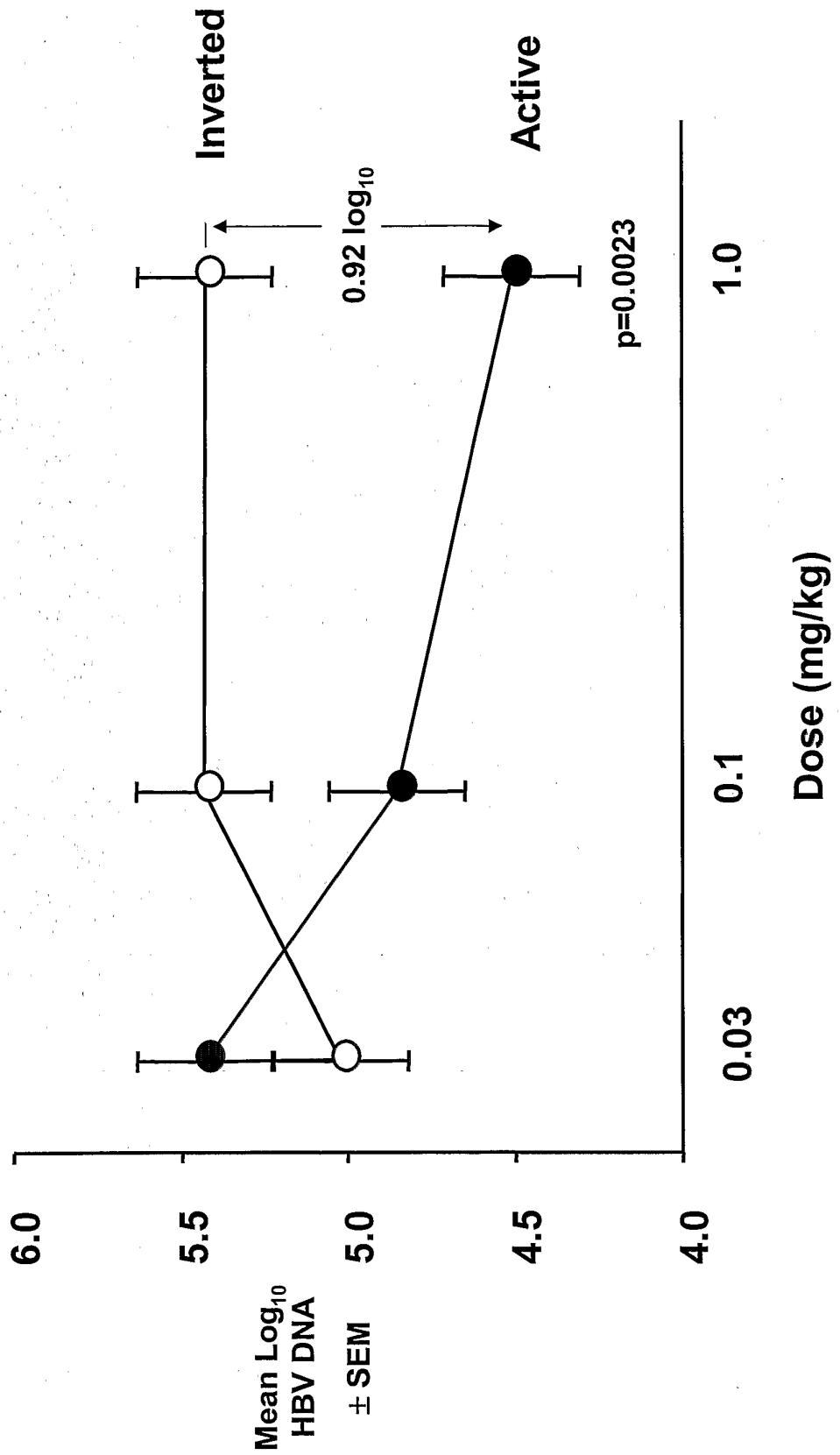
**Figure 90: HBV/siNA to site 1580 Combination Constructs**



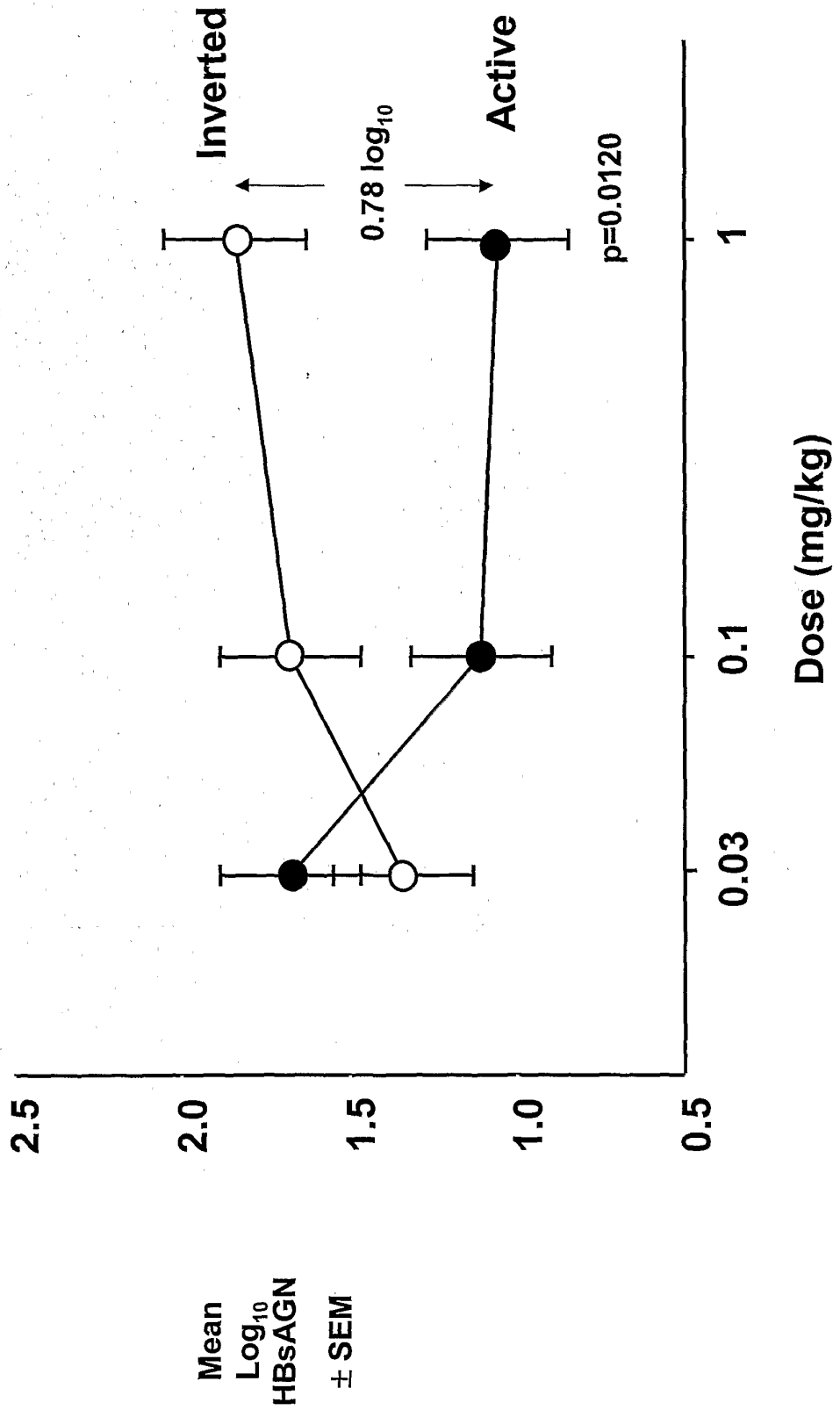
**Figure 90: HBV/siNA to site 1580 Combination Constructs**



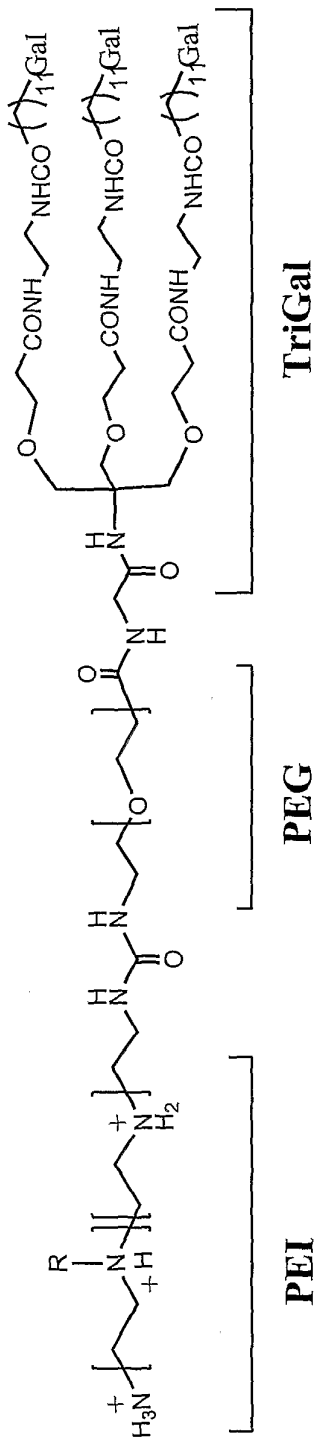
**Figure 91: PEI-Peg-Gal (3:1): Demonstration of Activity & Specificity HBV DNA**



**Figure 92: PEI-Peg-Gal (3:1): Demonstration of Activity & Specificity HBsAg**

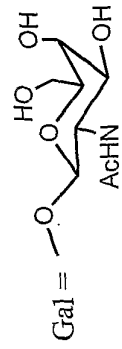


*Figure 93: General Structure of PEI-PEG-TriGal with a lipid linker*

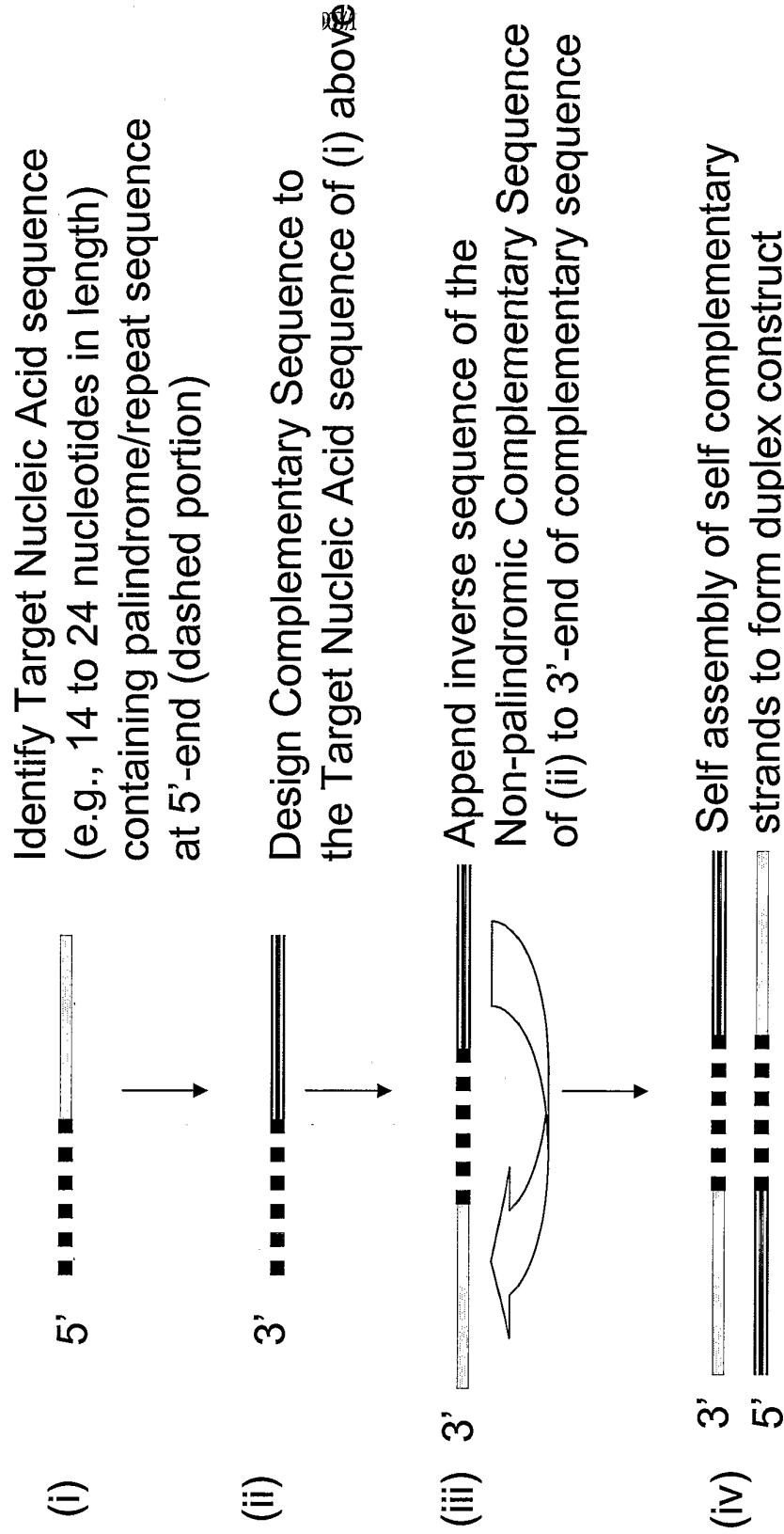


MW of PEI is 25000 Da

MW of PEG is 3400 Da

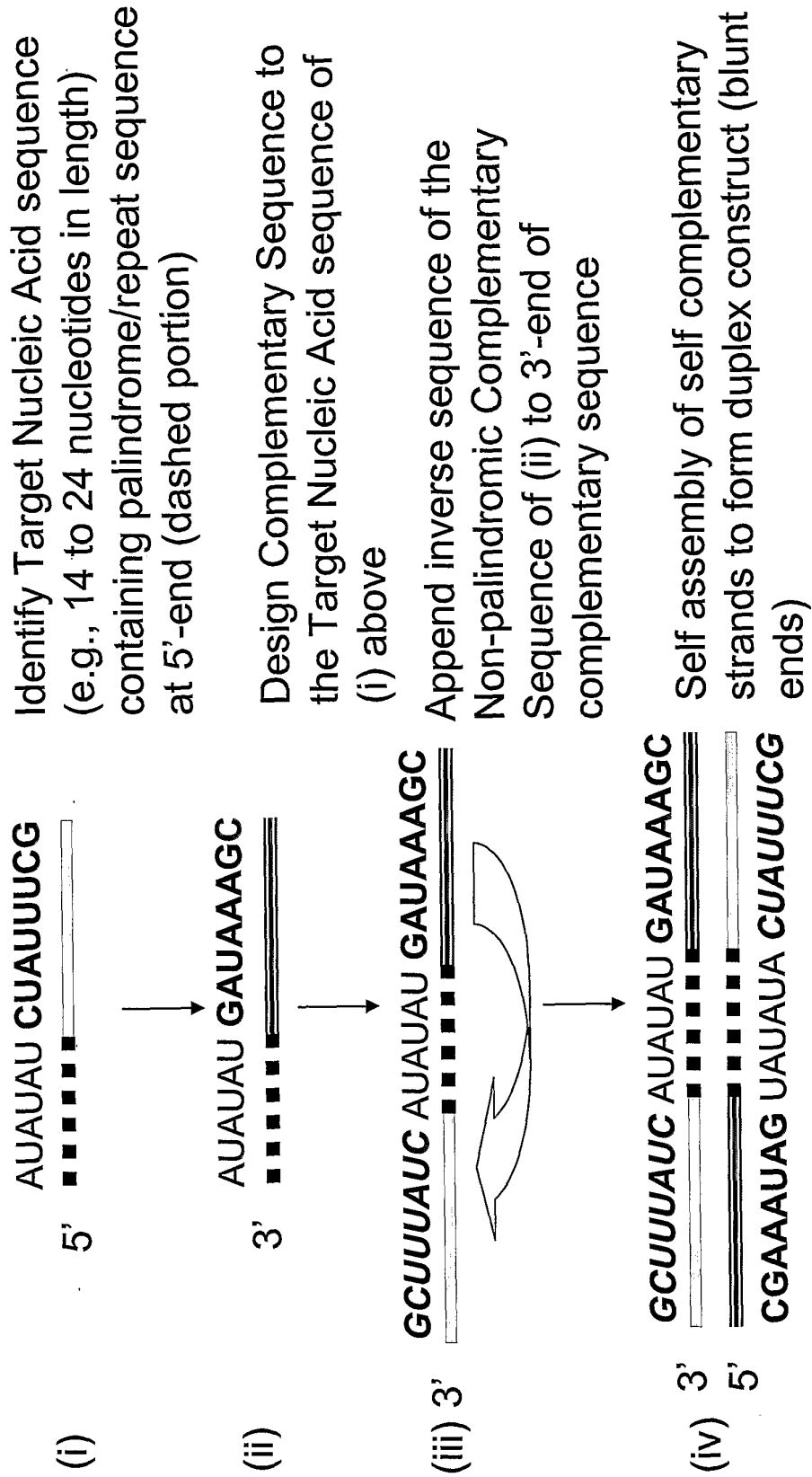


**Figure 94A: Duplex forming oligonucleotide constructs that utilize palindrome or repeat sequences**

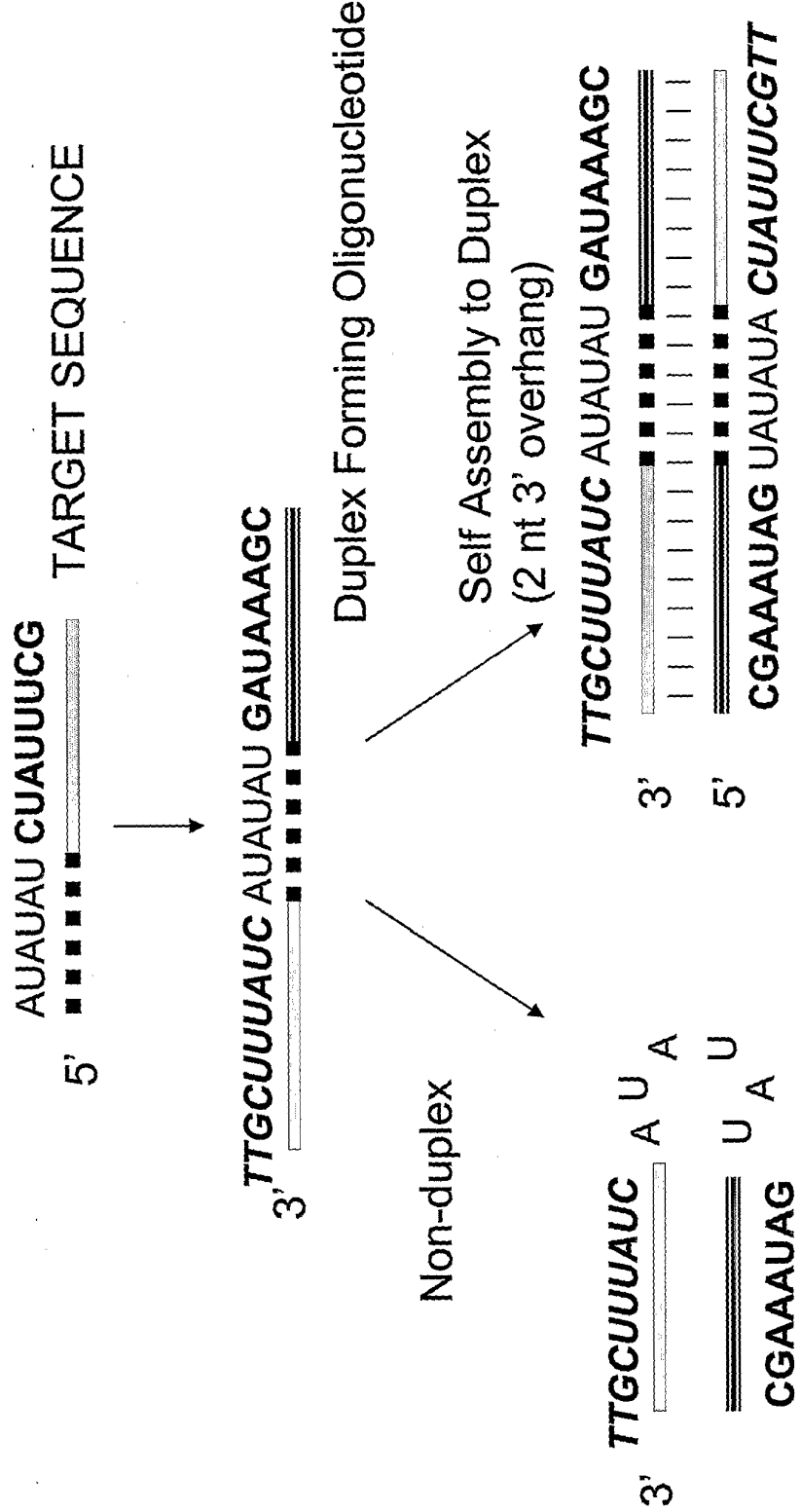




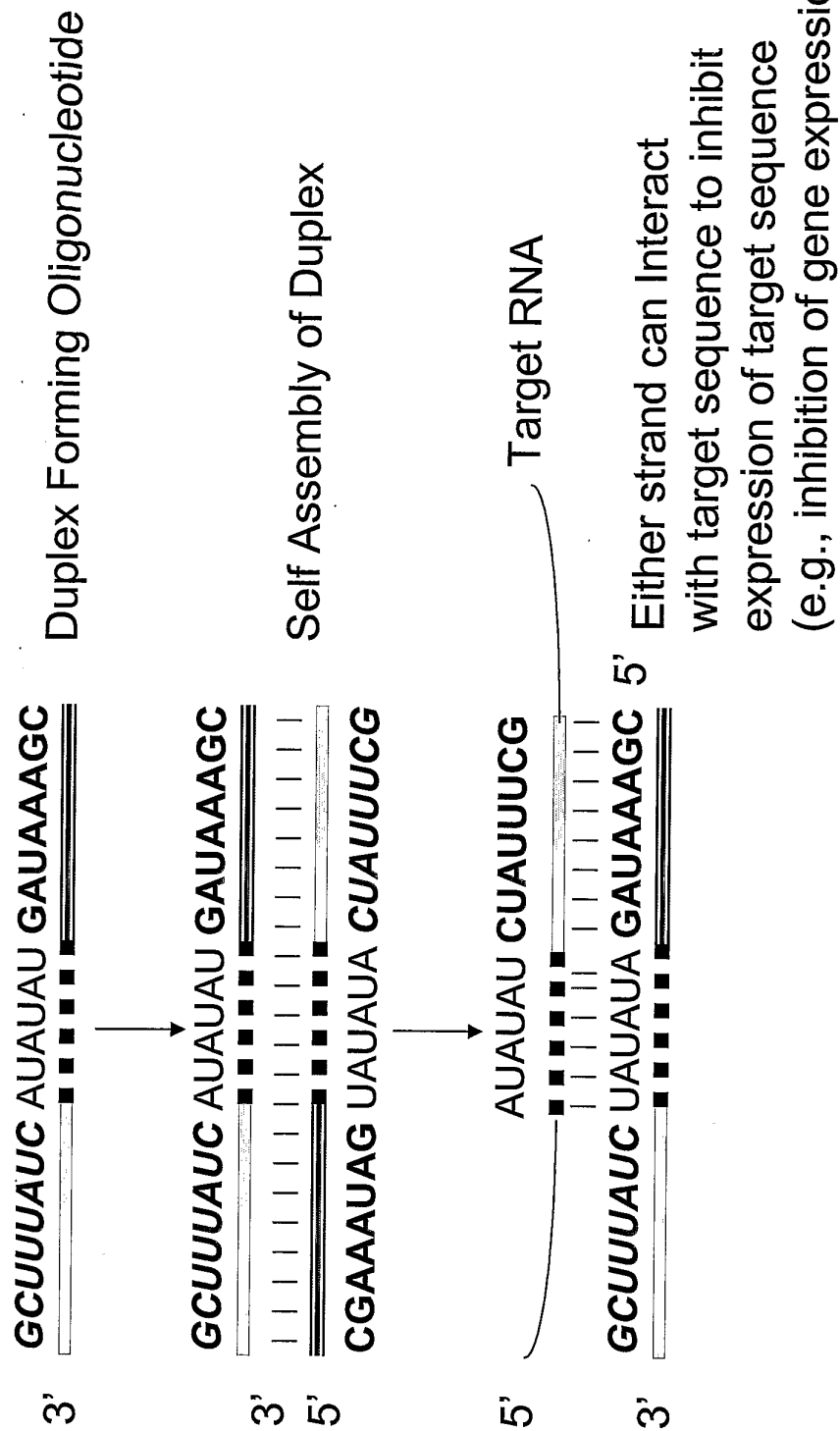
**Figure 94B: Example of a duplex forming oligonucleotide sequence that utilizes a palindrome or repeat sequence**



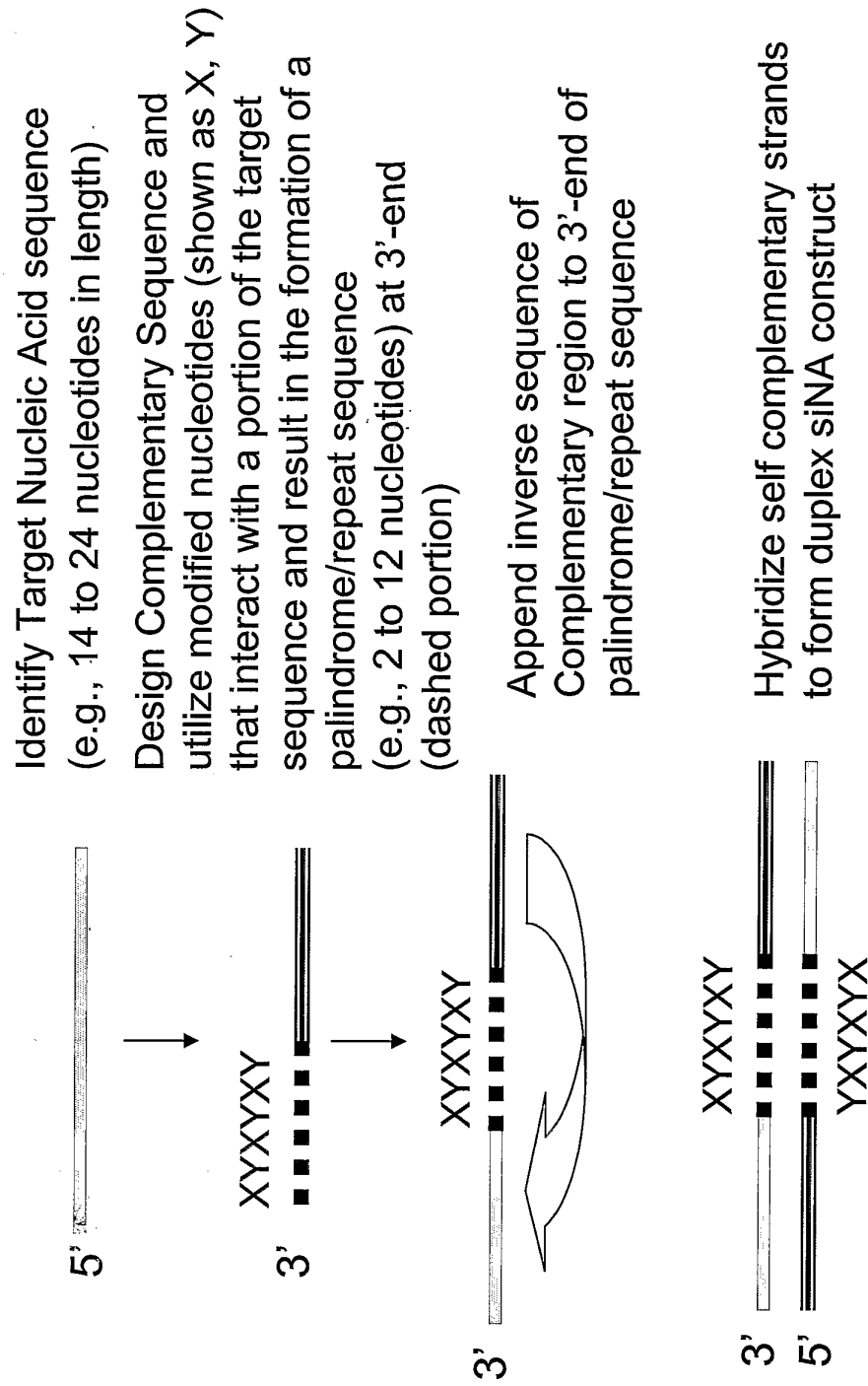
**Figure 94C: Example of a duplex forming oligonucleotide sequence that utilizes a palindrome or repeat sequence, self assembly**



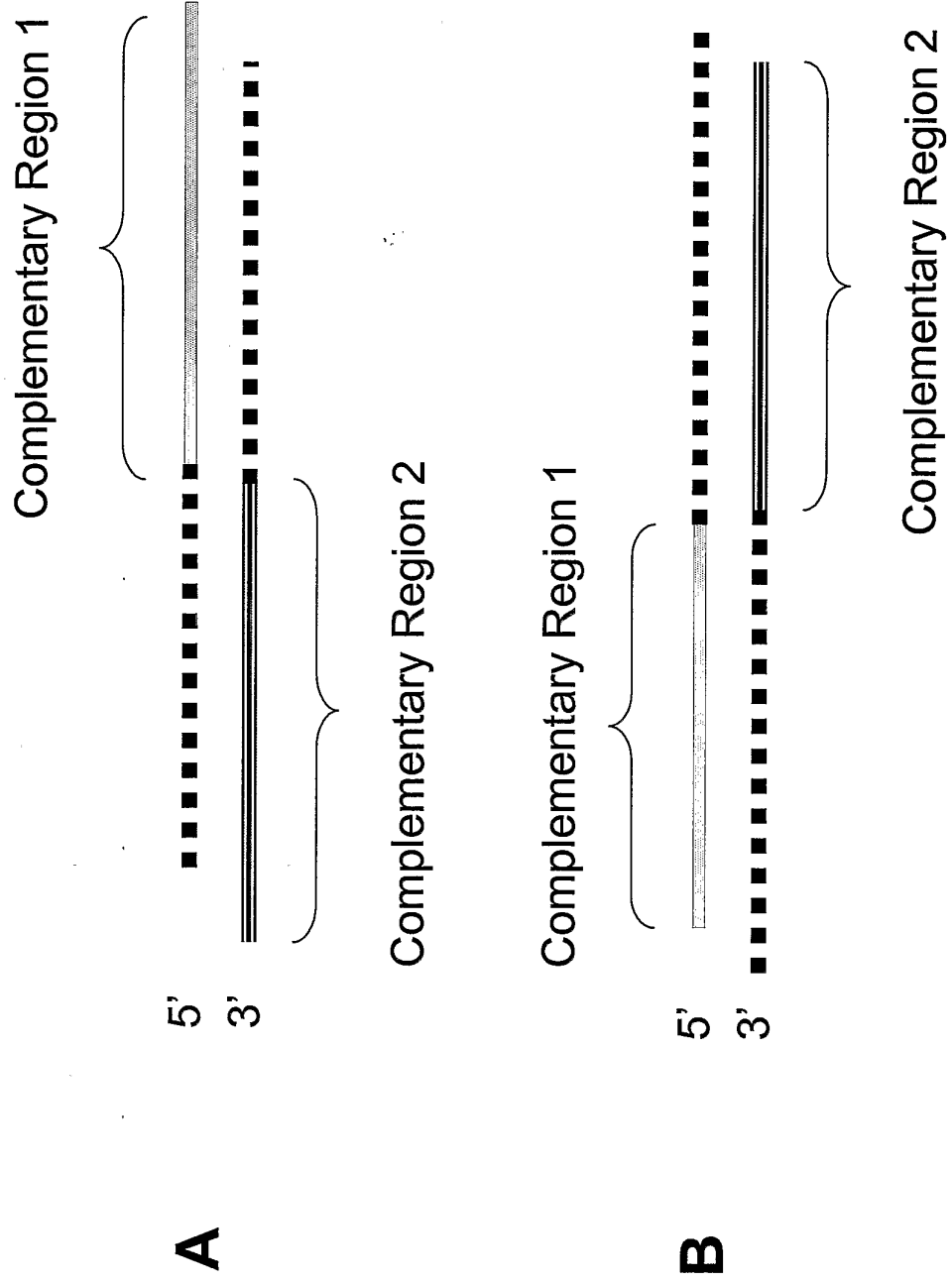
**Figure 94D: Example of a duplex forming oligonucleotide sequence that utilizes a palindrome or repeat sequence, self assembly and inhibition of Target Sequence Expression**



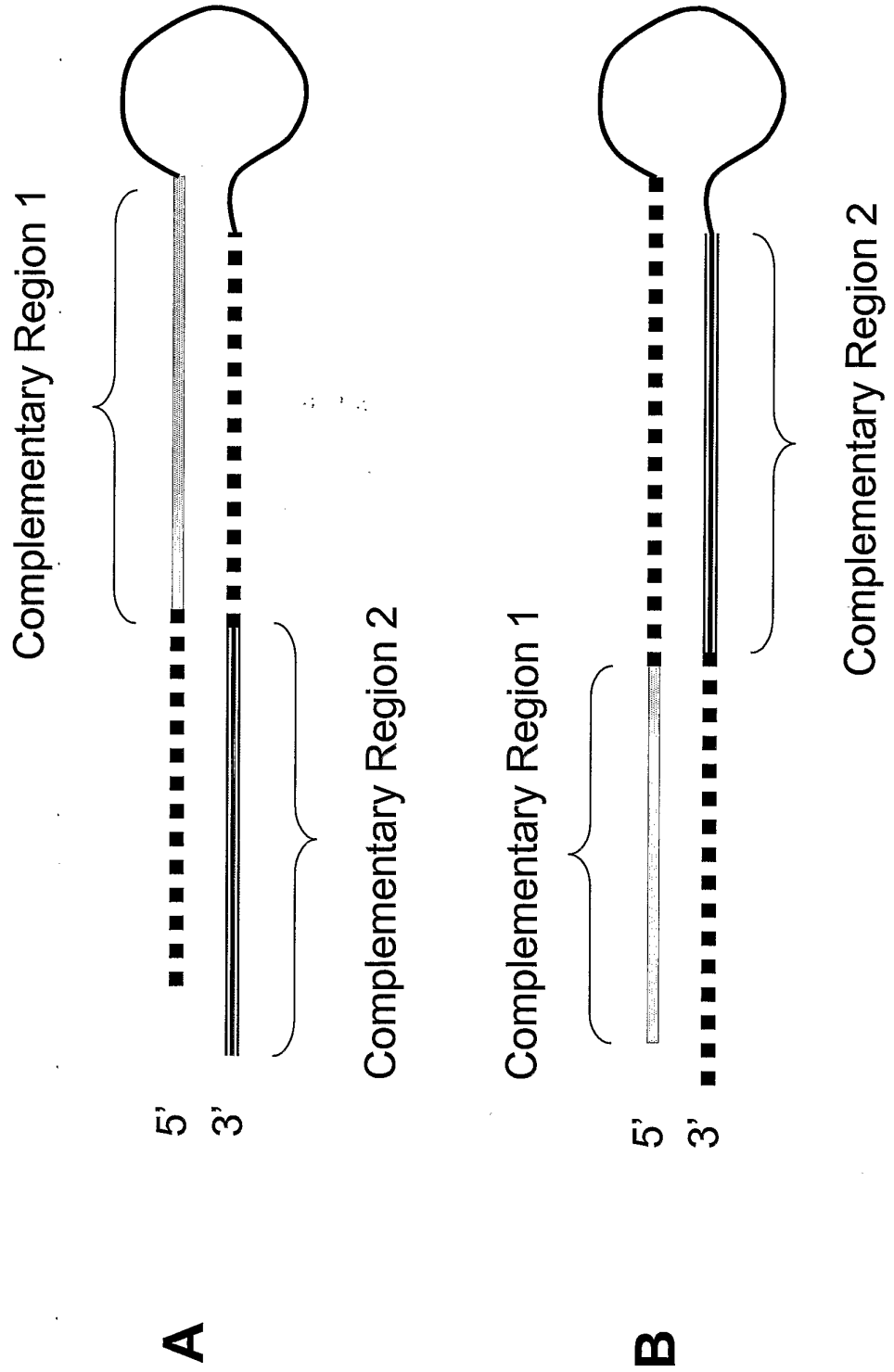
**Figure 95: Duplex forming oligonucleotide constructs that utilize artificial palindrome or repeat sequences**



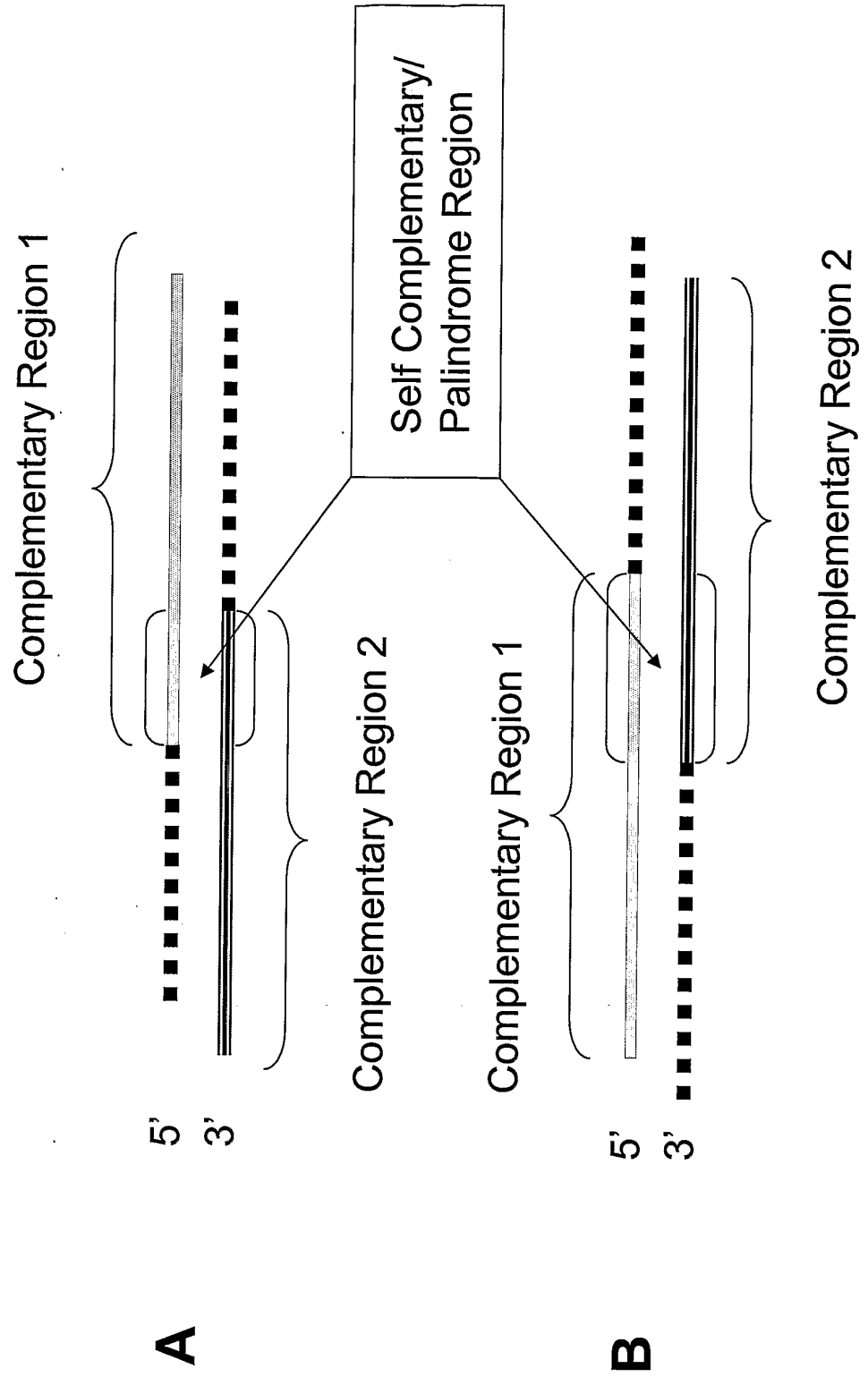
**Figure 96: Examples of double stranded multifunctional siNA constructs with distinct complementary regions**



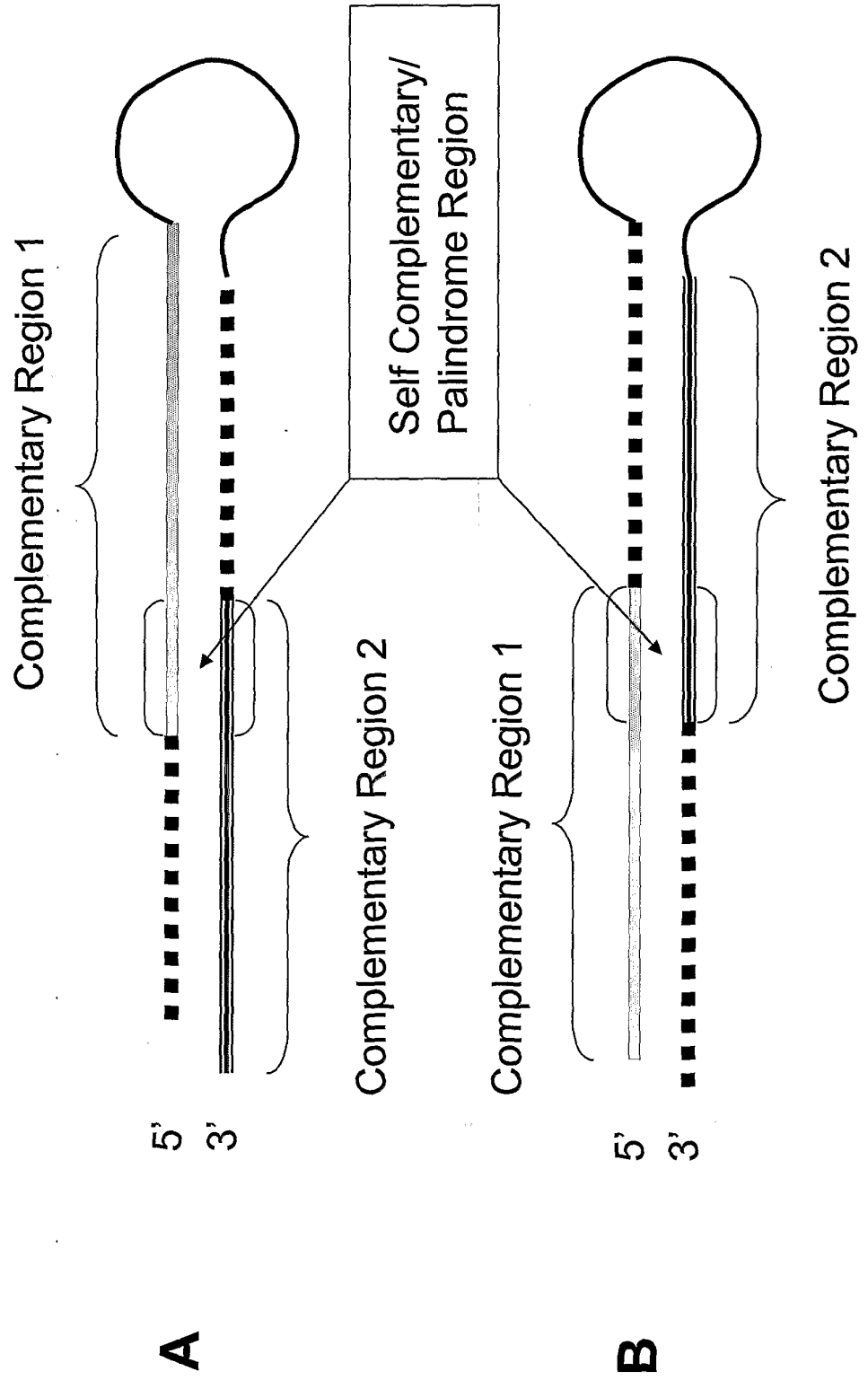
**Figure 97: Examples of hairpin multifunctional siNA constructs with distinct complementary regions**



**Figure 98: Examples of double stranded multifunctional siNA constructs with distinct complementary regions and a self complementary/palindrome region**

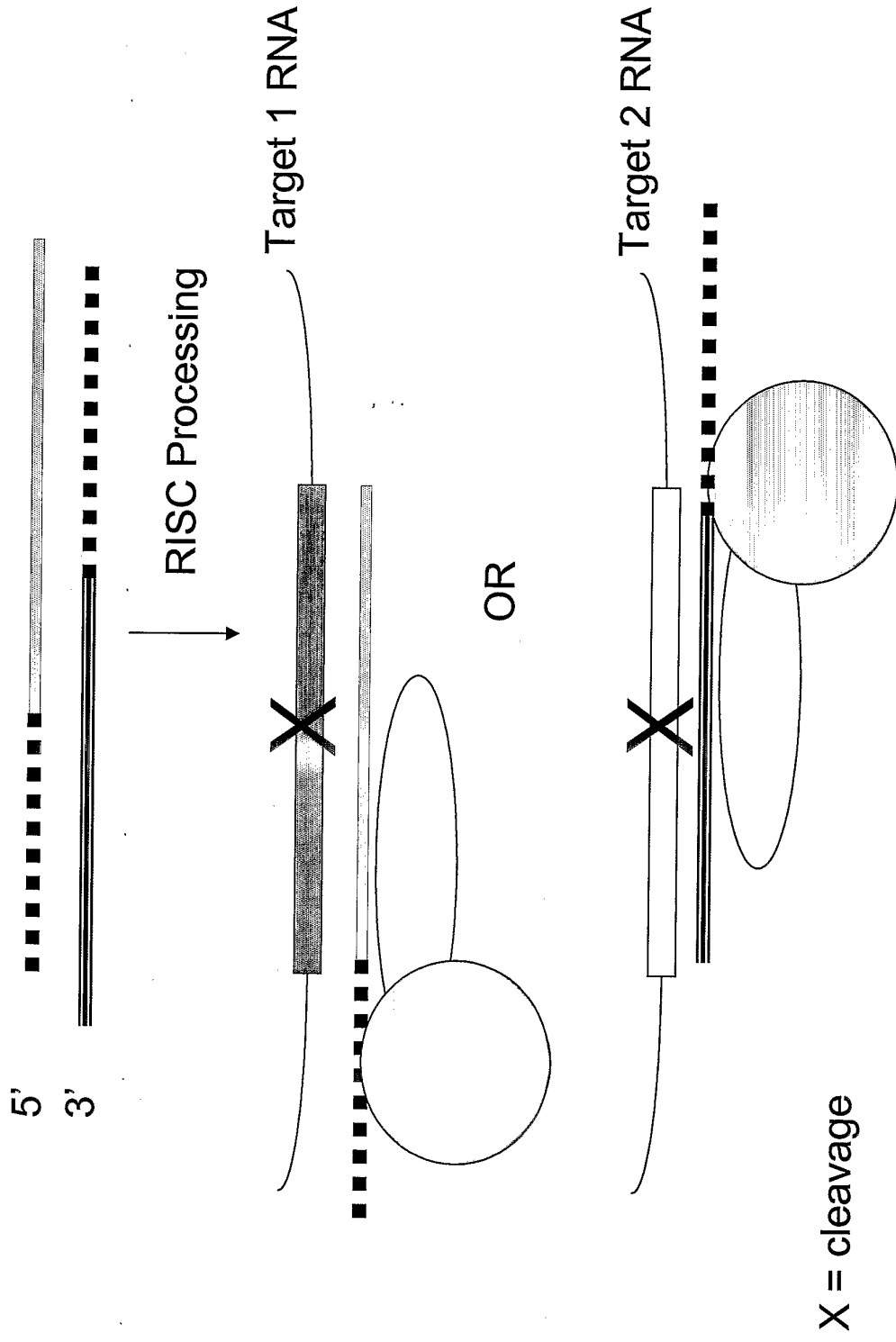


**Figure 99: Examples of hairpin multifunctional siNA constructs with distinct complementary regions and a self complementary/palindrome region**

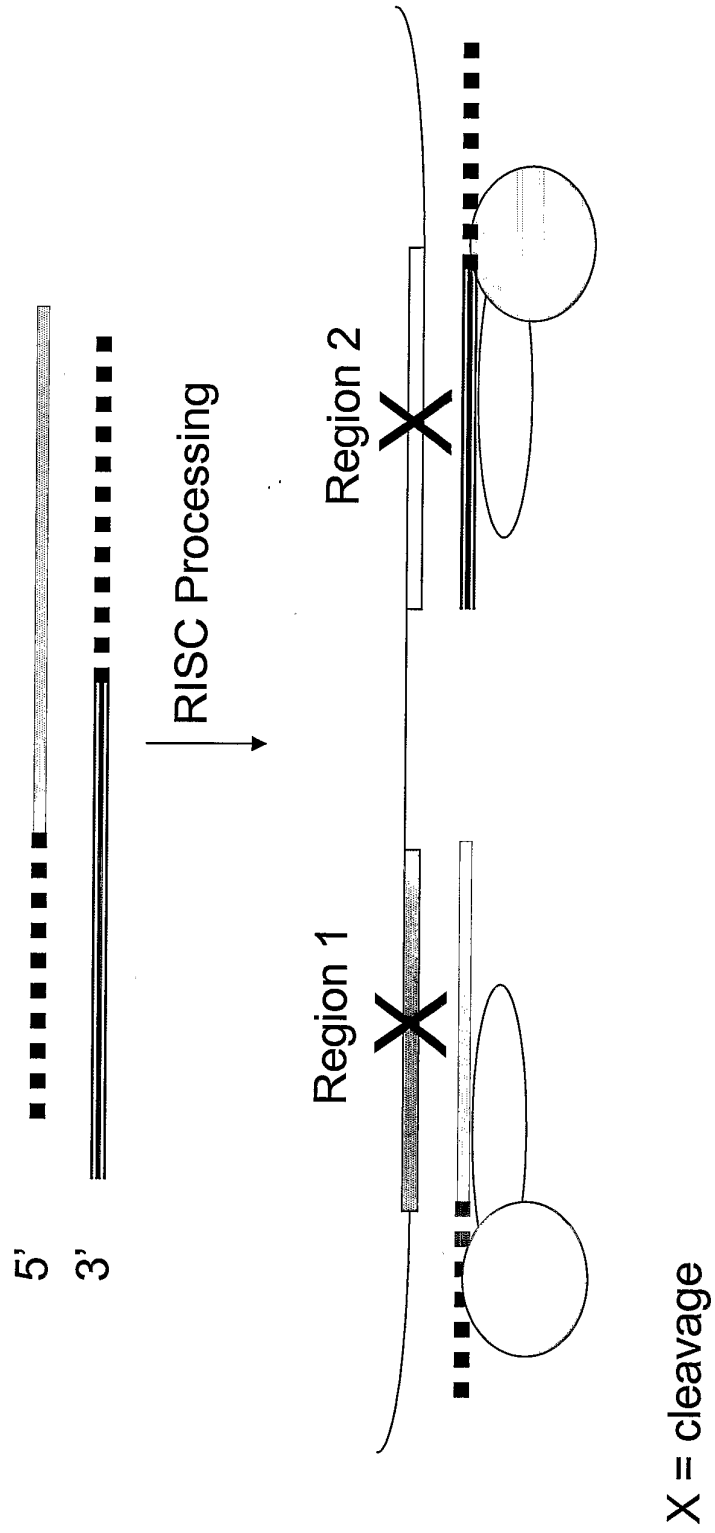




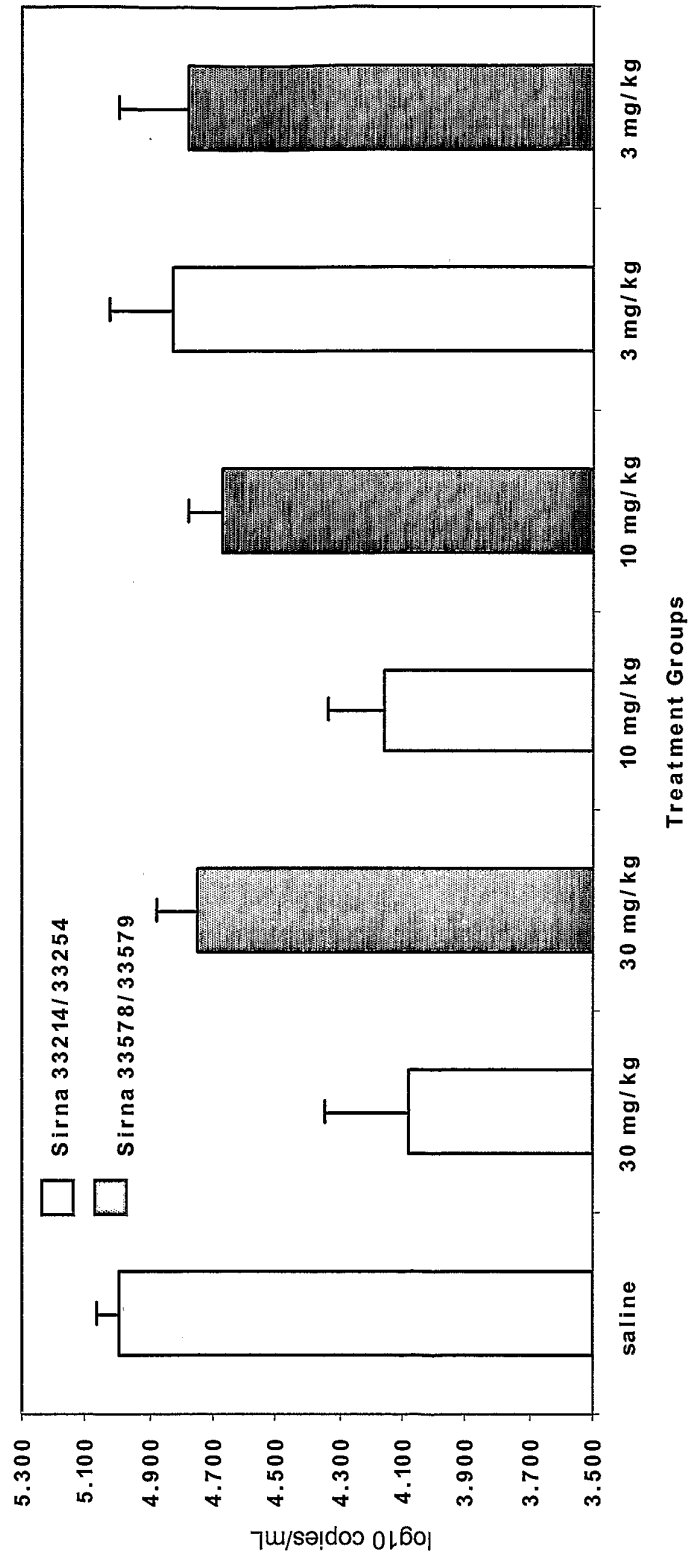
**Figure 100: Example of multifunctional siNA targeting two separate target nucleic acid sequences**



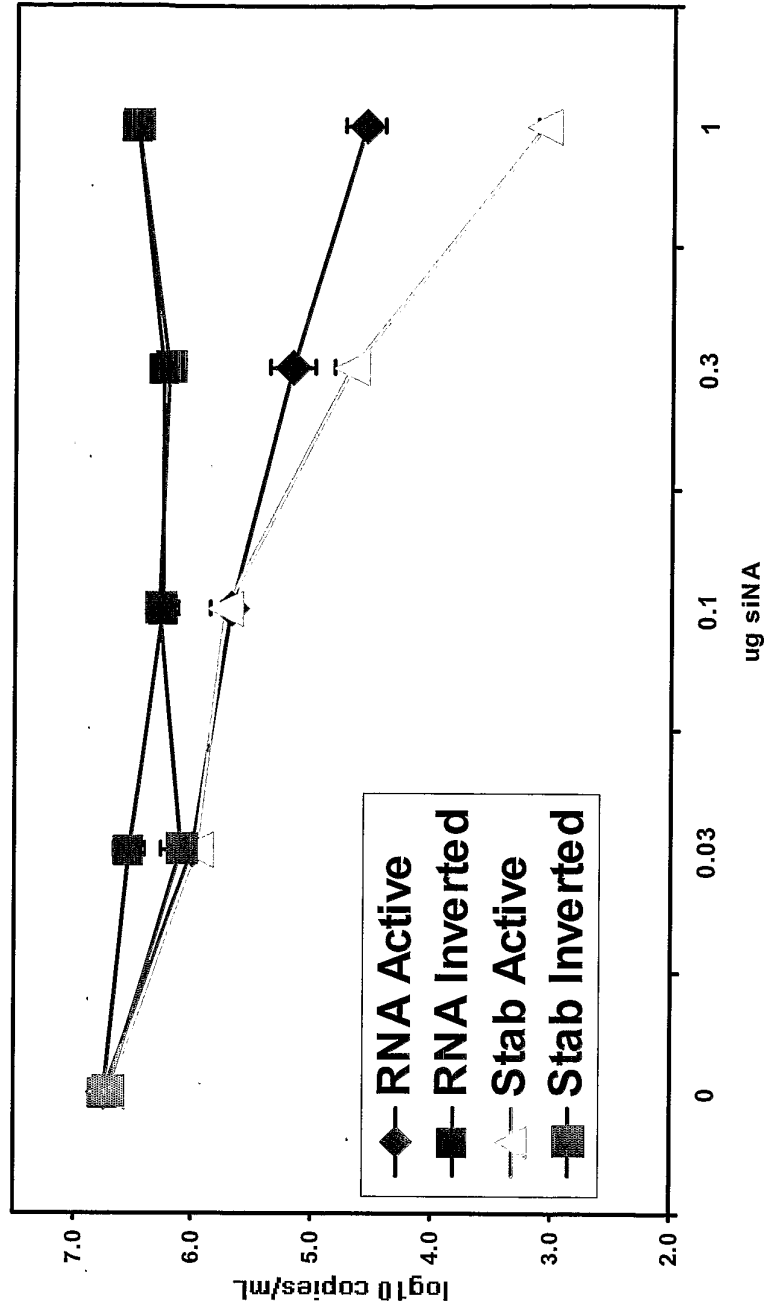
**Figure 101: Example of multifunctional siNA targeting two regions within the same target nucleic acid sequence**



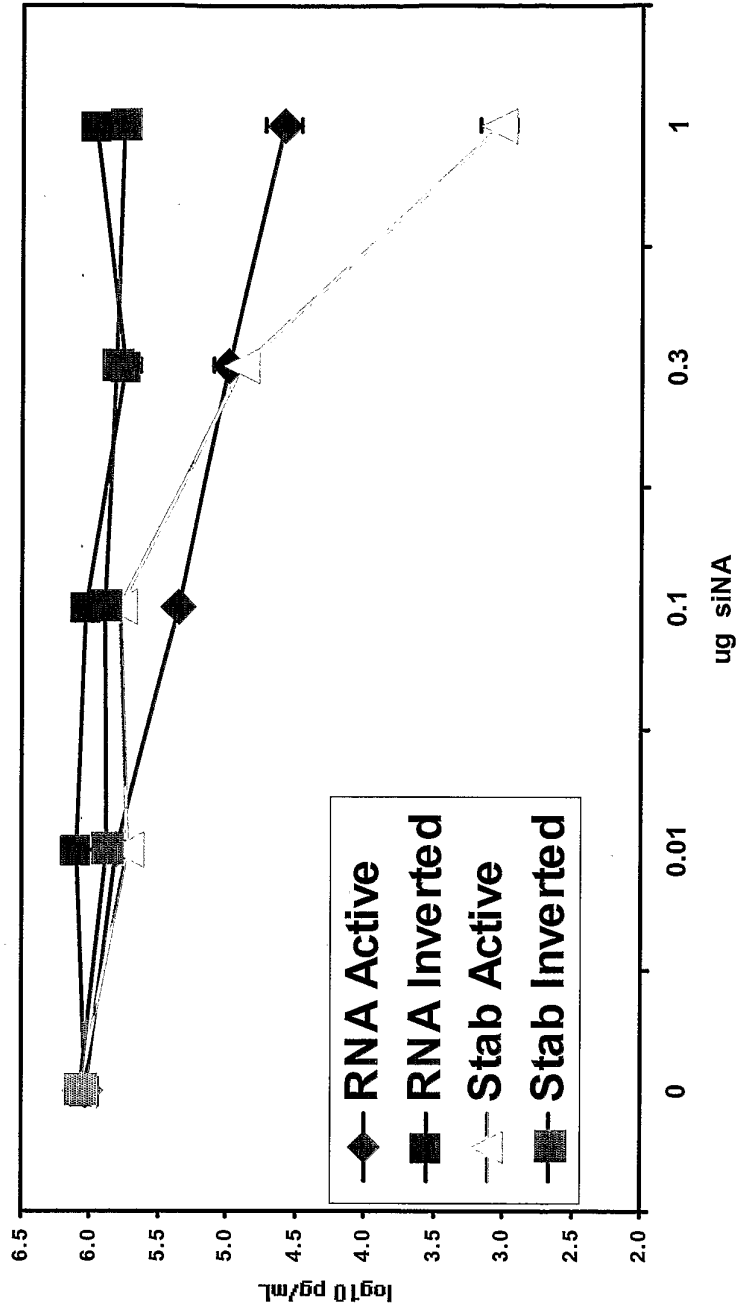
**Figure 102: Activity of Systemically Administered Stabilized siNA in HBV Mouse Model: Serum HBV DNA Levels**



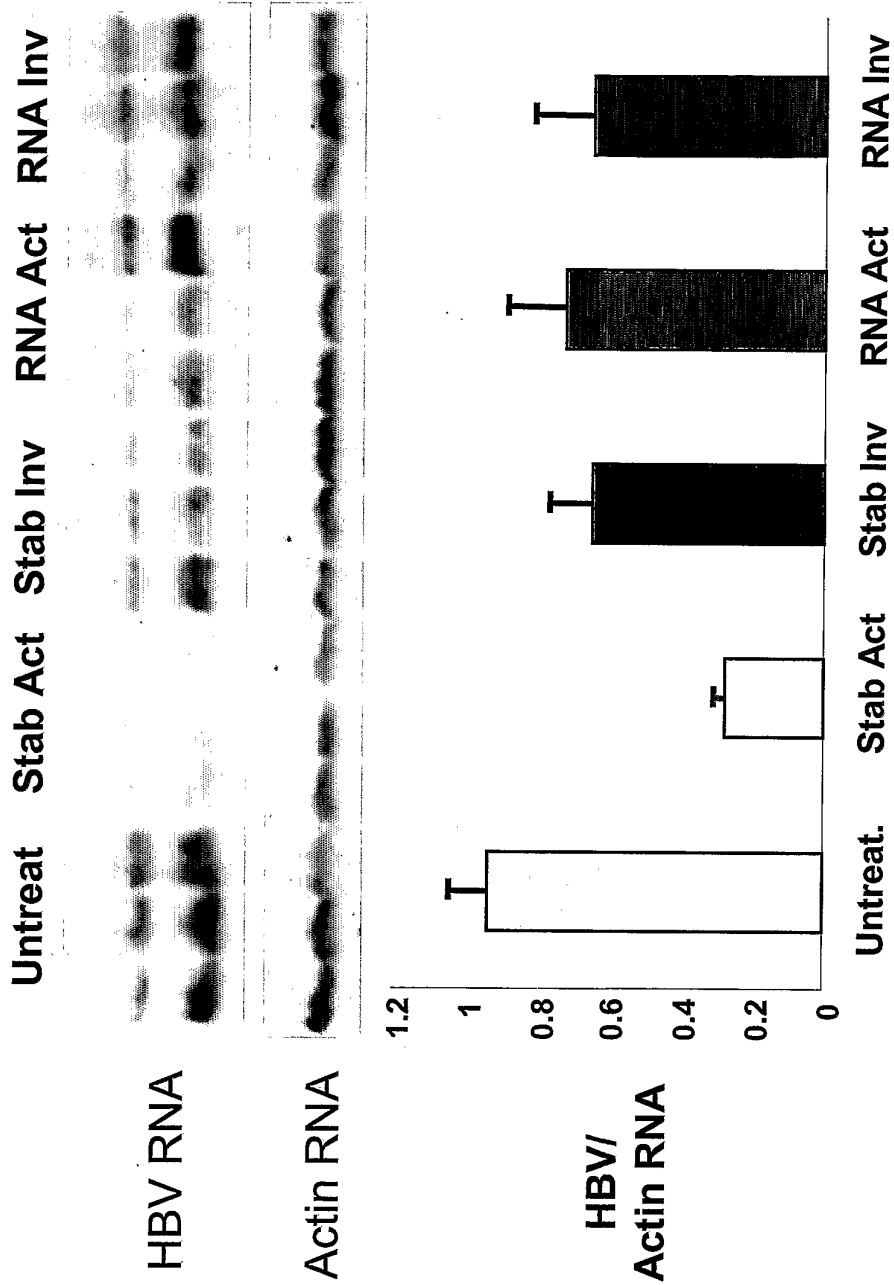
**Figure 103A: Activity of Systemically Administered Stabilized siNA vs all RNA siNA in HBV Mouse Model: Serum HBV DNA Levels**



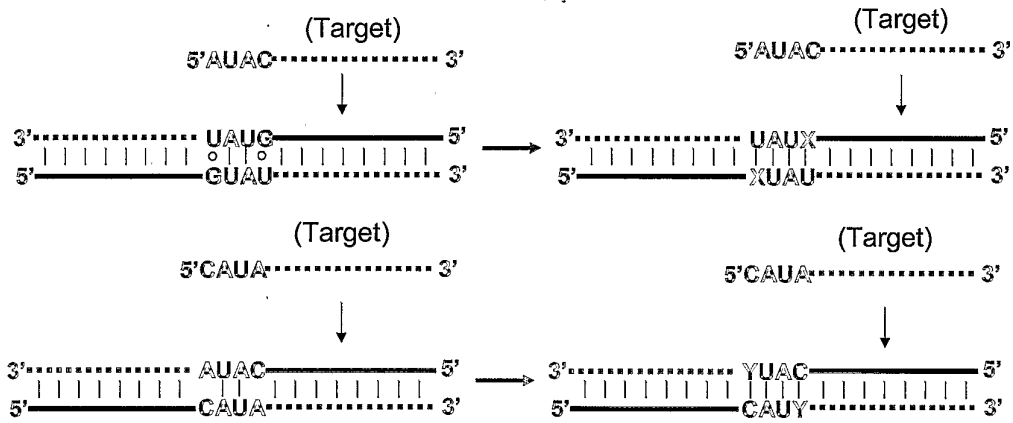
**Figure 103B: Activity of Systemically Administered Stabilized siNA vs all RNA siNA in HBV Mouse Model: Serum HBsAg Levels**



**Figure 103C: Activity of Systemically Administered Stabilized siNA vs all RNA siNA in HBV Mouse Model: Liver HBV RNA Levels**



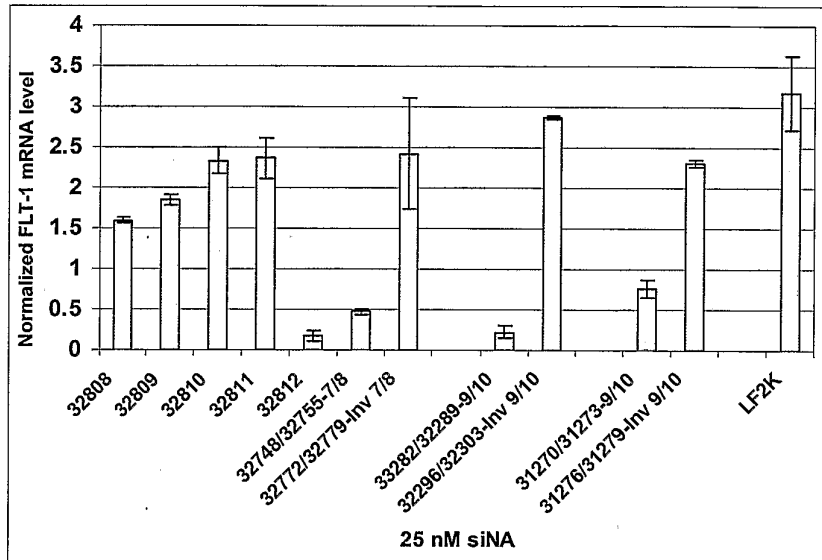
**Figure 104: Examples of introducing artificial palindrome sequences in DFO constructs with a target nucleic acid not having a palindrome/repeat**



X = 2-aminopurine  
 Y = 2-amino-1,6-dihydropurine

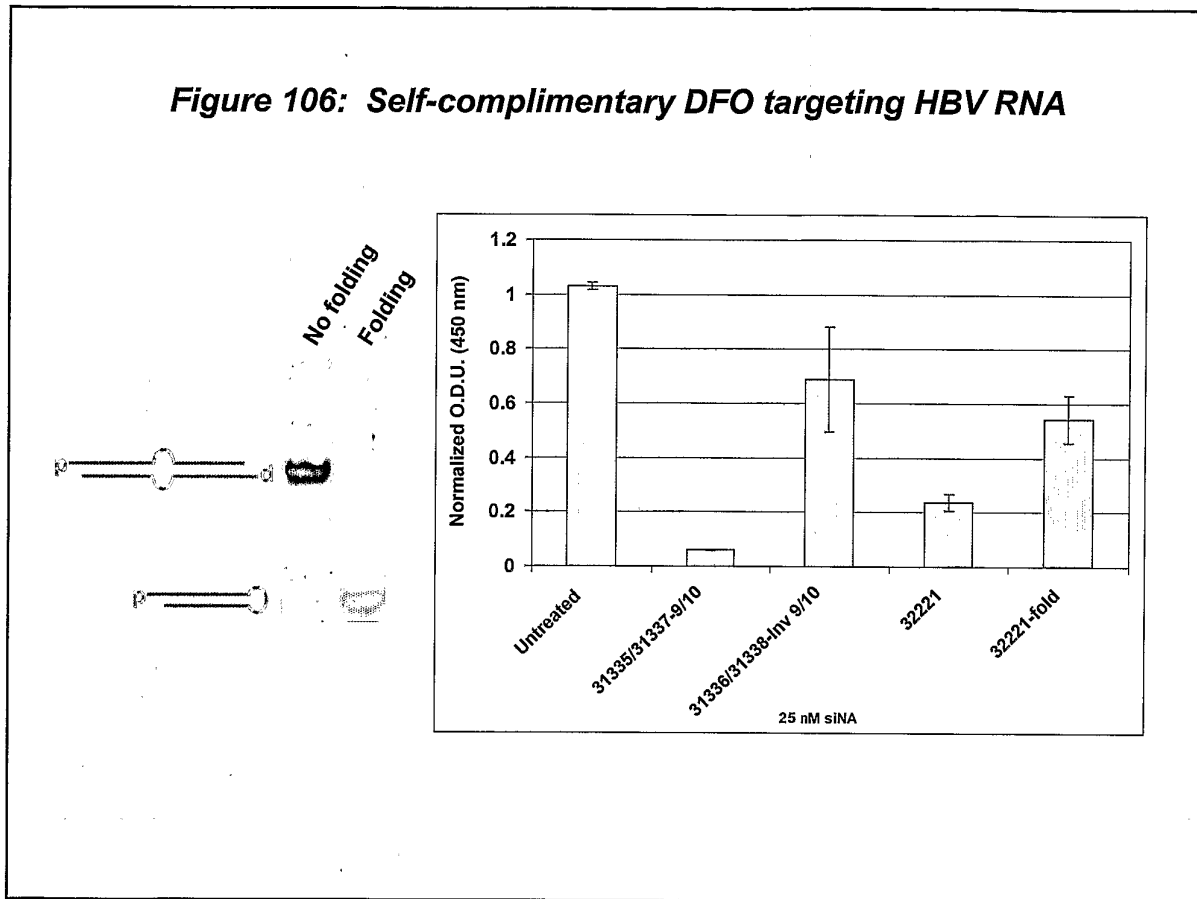
Similarly, other base modified pyrimidines can be utilized to make non-natural base pair with purines or vice versa

**Figure 105: Self-complimentary DFO targeting VEGFR1 RNA**

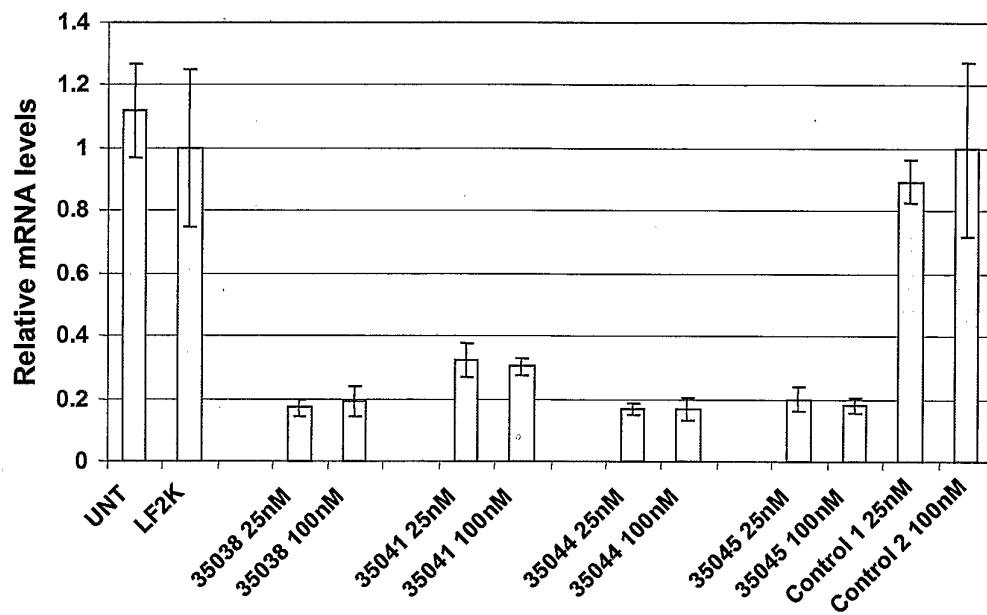




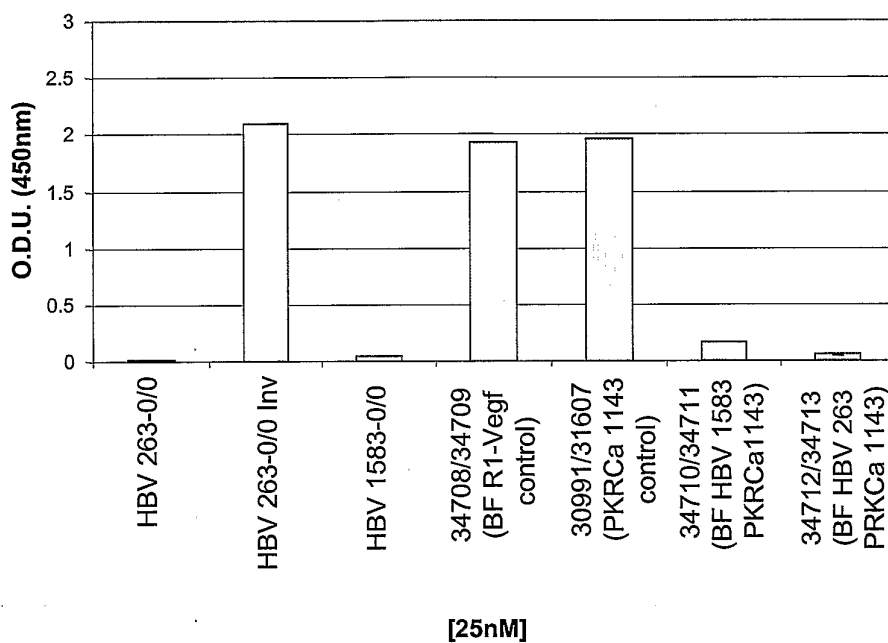
**Figure 106: Self-complimentary DFO targeting HBV RNA**



**Figure 109: DFO mediated inhibition of TGF-beta receptor RNA expression**

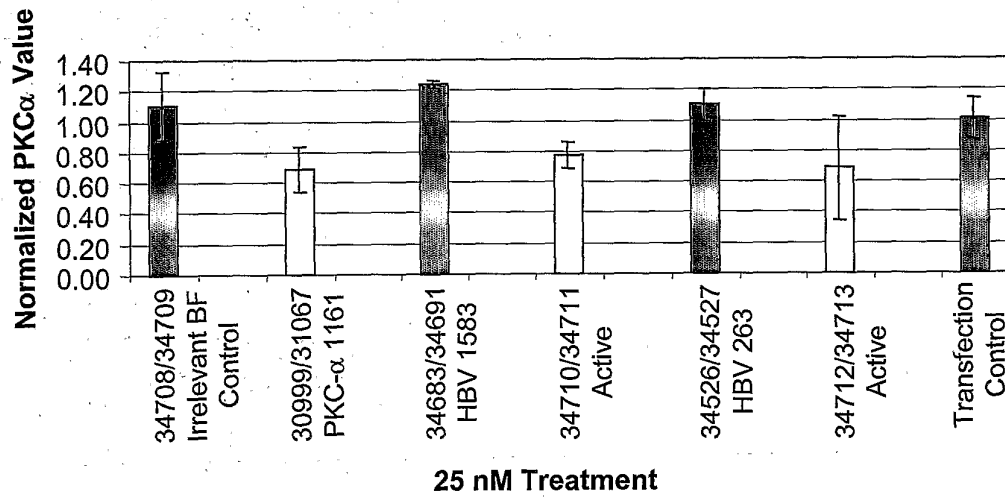


**Figure 110: Multifunctional siNA mediated inhibition of HBV RNA expression**

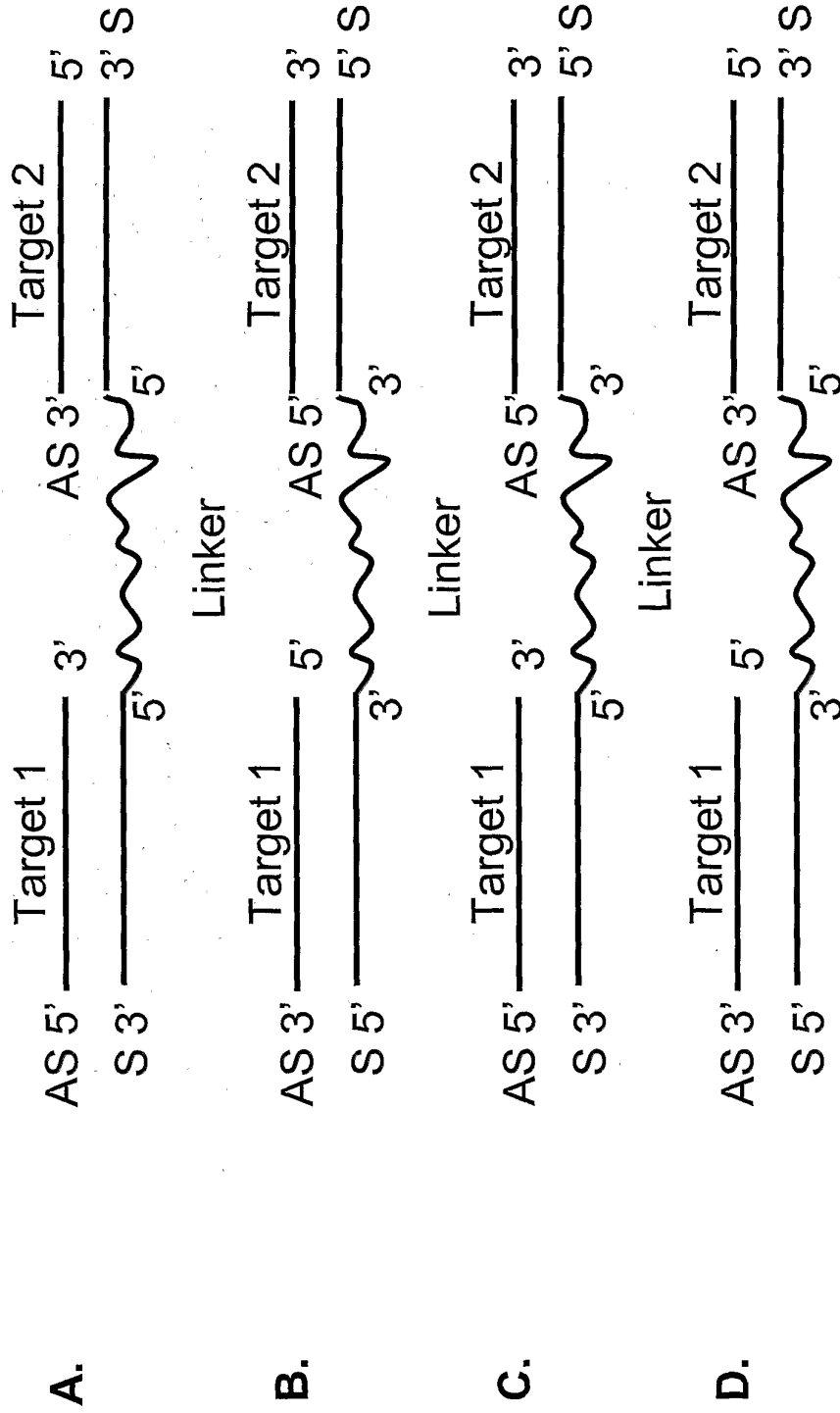


**Figure 111: Multifunctional siNA mediated inhibition of PKC-alpha RNA expression**

**HepG2 24h PKC $\alpha$  mRNA Expression  
0.25  $\mu$ l/well LF2K Transfection  
5000 Cells/Well**

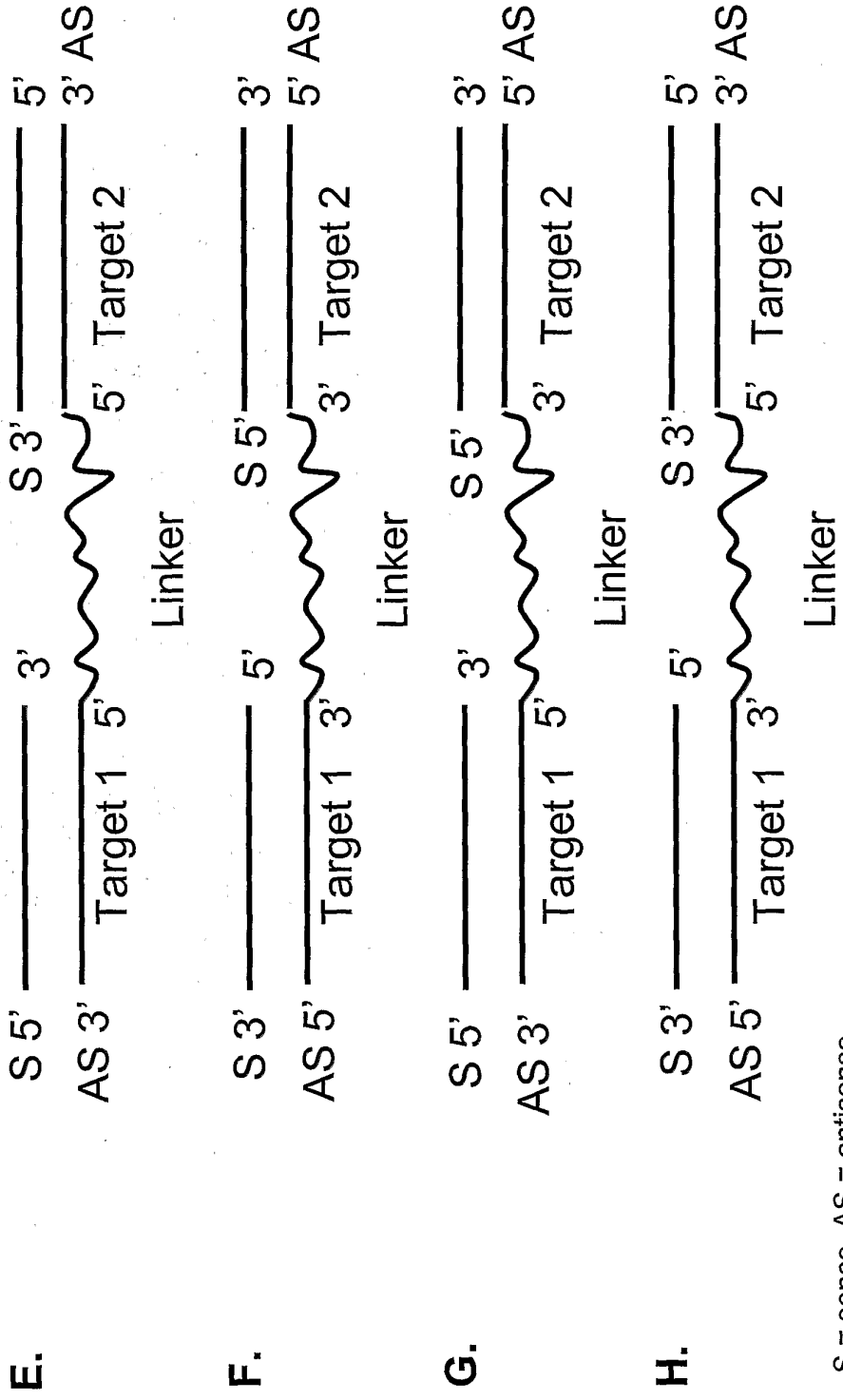


**Figure 112: Tethered Multifunctional siNA design**



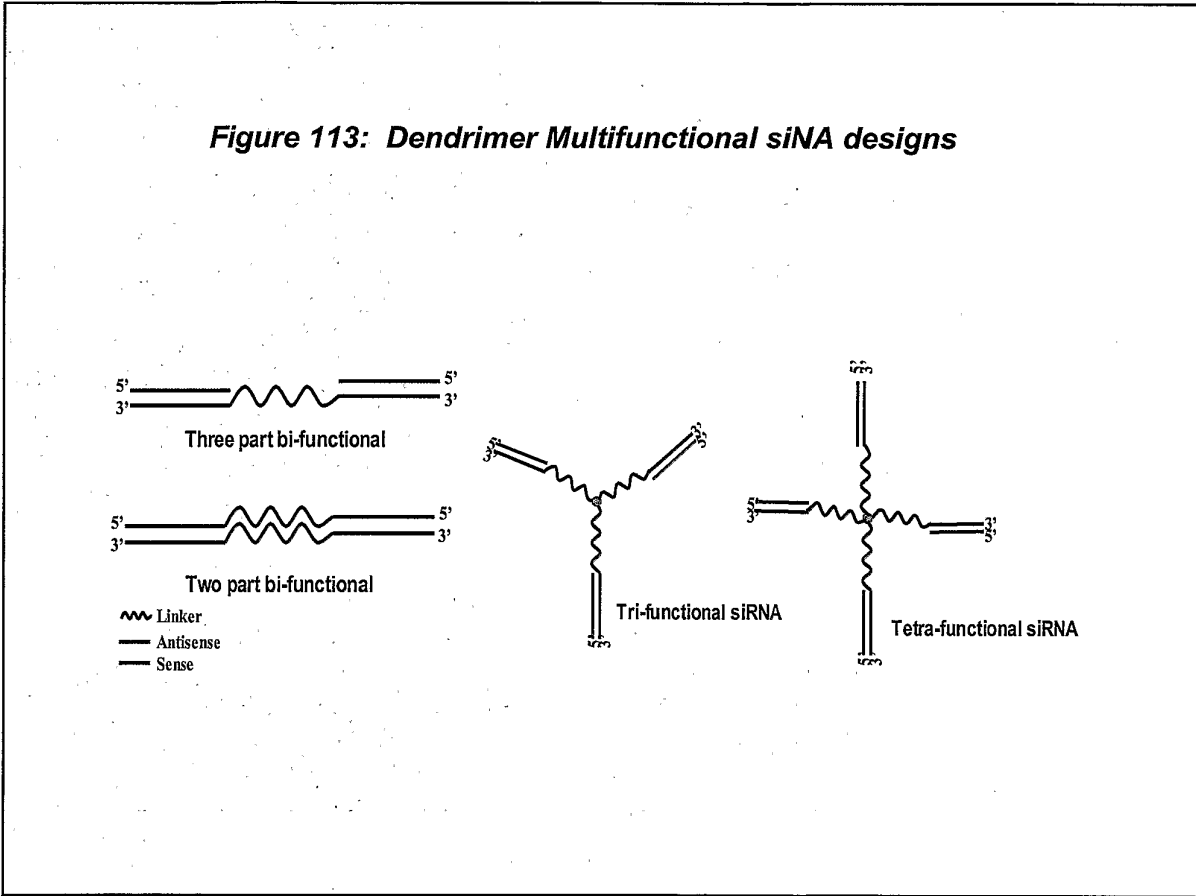
S = sense, AS = antisense  
 Linker region can be nucleotide or non-nucleotide linker, and can optionally be decorated, for example with conjugates polymers or aptamers, such as for delivery purposes.

**Figure 112: Tethered Multifunctional siNA design**

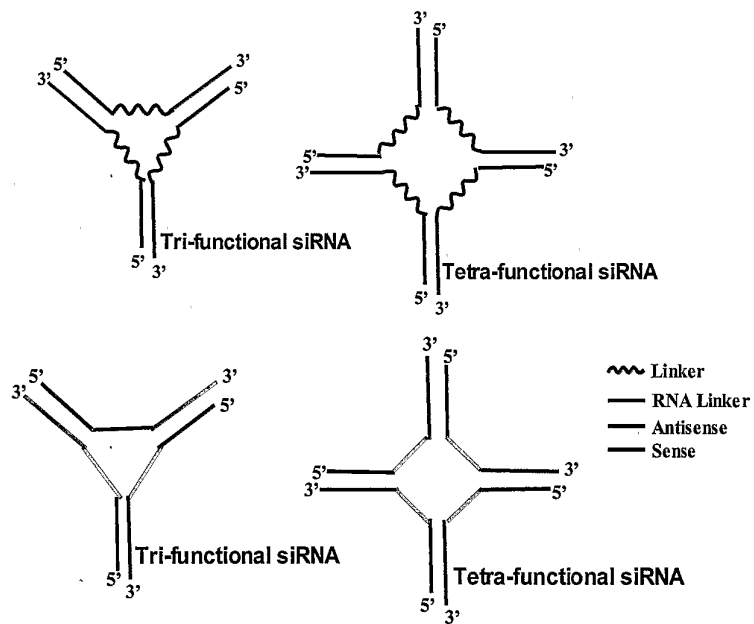


S = sense, AS = antisense  
 Linker region can be nucleotide or non-nucleotide linker, and can optionally be decorated, for example with conjugates polymers or aptamers, such as for delivery purposes.

**Figure 113: Dendrimer Multifunctional siRNA designs**

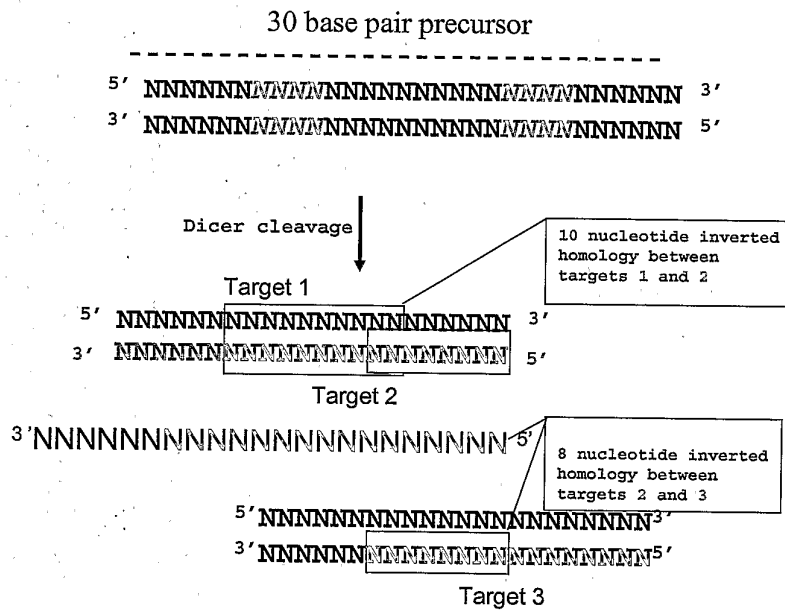


**Figure 114: Supramolecular Multifunctional siRNA designs**



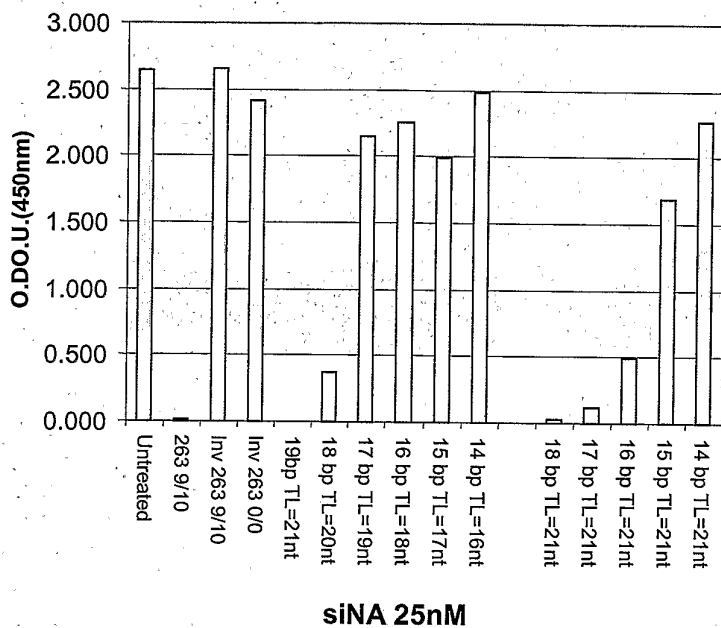


**Figure 115: Dicer enabled multifunctional siNA design**



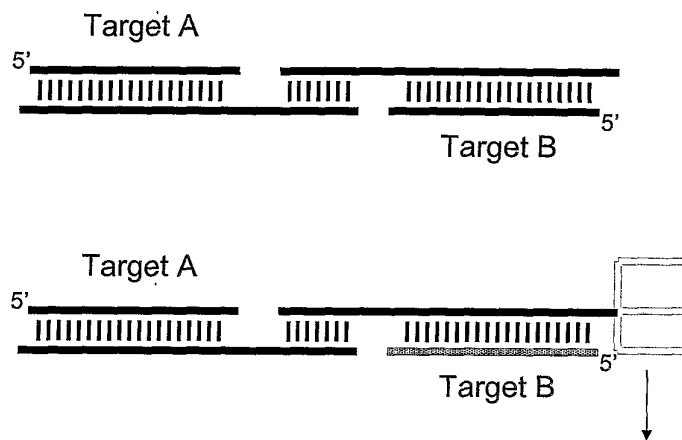


**Figure 117: siNA base pair walk**



**siNA 25nM**

**Figure 118: Additional Multifunctional siNA designs**



Targeting Ligand/branched Ligand  
 e.g. Cholesterol, N-acetyl Galactosamine,  
 Lipid, Peptide, RGD etc.

**Figure 119: Additional Multifunctional siNA designs**

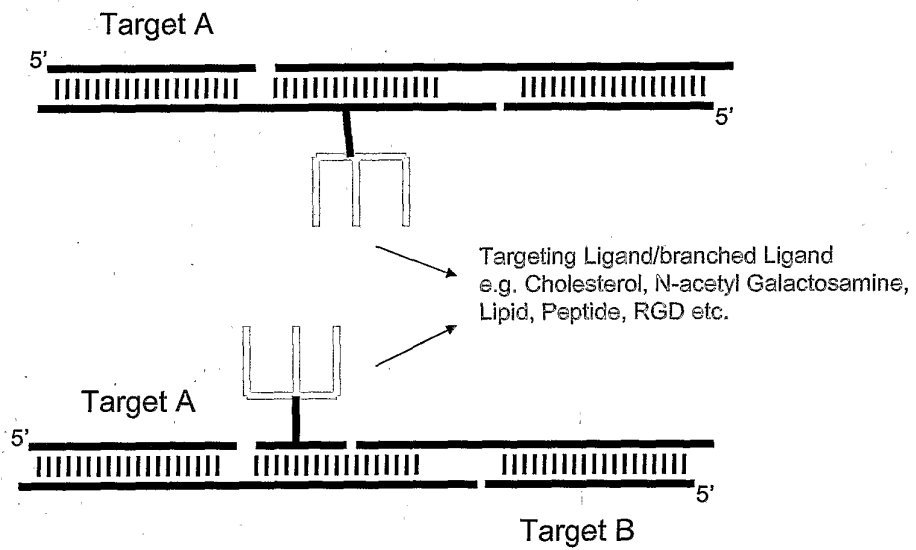


Figure 120: siNA length walk

