

(No Model.)

P. A. BOWEN.
WATER COCK.

No. 312,077.

Patented Feb. 10, 1885.

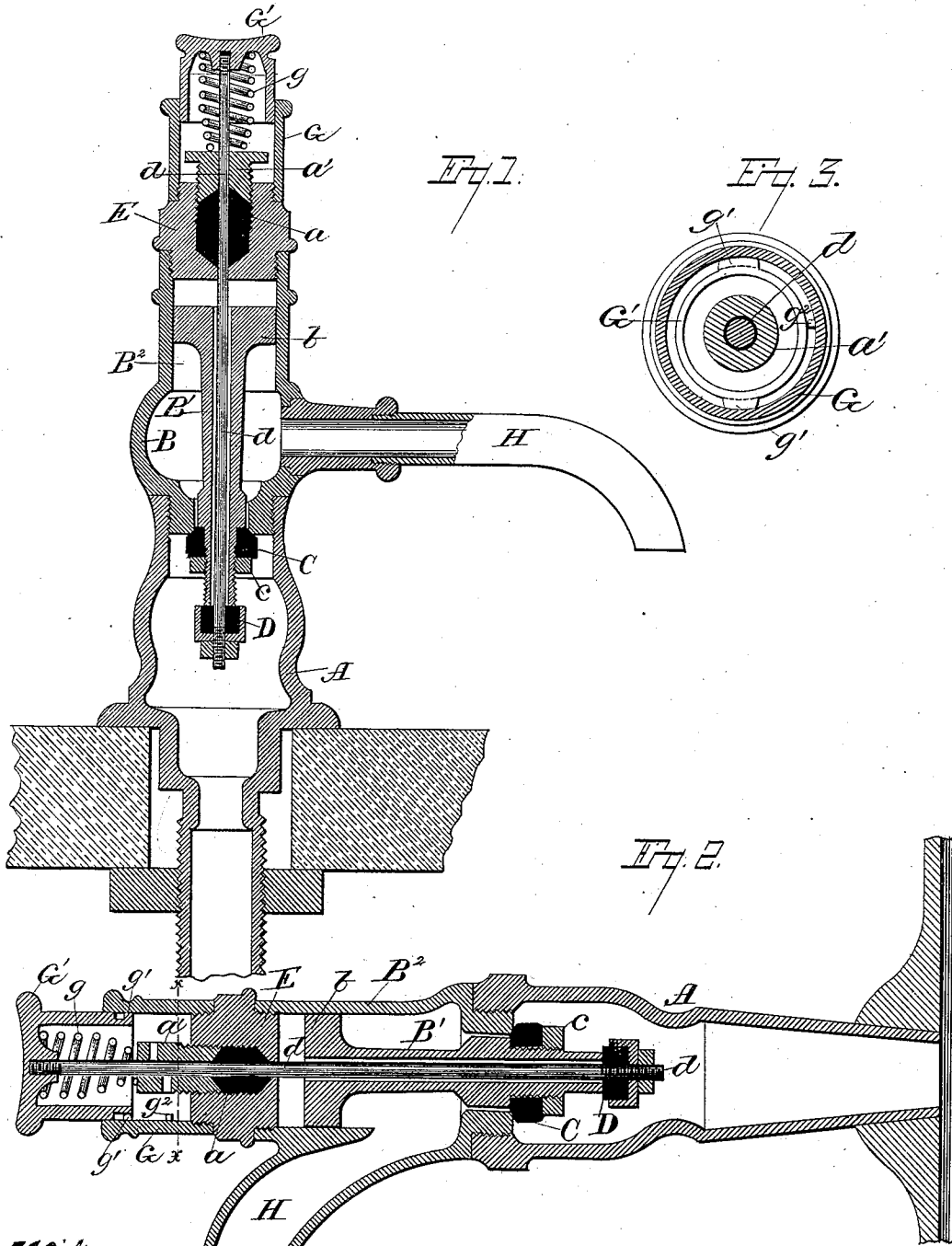

Witnesses
E. Spence
R. Platz

Inventor:
Philip A. Bowen
By *Seal & Underwood*
Attorneys.

UNITED STATES PATENT OFFICE.

PHILIP A. BOWEN, OF MILWAUKEE, WISCONSIN, ASSIGNOR OF ONE-HALF
TO LOEFFELHOLZ & CO., OF SAME PLACE.

WATER-COCK.

SPECIFICATION forming part of Letters Patent No. 312,077, dated February 10, 1885.

Application filed February 19, 1884. (No model.)

To all whom it may concern:

Be it known that I, PHILIP A. BOWEN, of Milwaukee, in the county of Milwaukee, and in the State of Wisconsin, have invented certain new and useful Improvements in Water-Cocks; and I do hereby declare that the following is a full, clear, and exact description thereof.

My invention relates to fluid cocks or valves, and will be fully described hereinafter.

In the drawings, Figure 1 is a central longitudinal section of a vertical cock embodying my invention. Fig. 2 is a similar view of a horizontal cock also embodying my invention. Fig. 3 is a cross-section on line *x x*, Fig. 2, looking toward the push-button *G'*.

A is the hollow stand that leads to the water-main.

B is a valve-chamber that is screwed into the stand A.

B' is a piston, the head *b* of which is loosely fitted in the barrel B² of the valve-chamber. This piston has a hollow stem that projects through the valve-chamber, and is furnished with a valve, C, that is held in place by a nut, *c*. Through the piston B' a rod, *d*, is passed to receive a valve, D, that has its seat on the inner or lower end of the stem of piston B'. The bore in the stem of piston B' is considerably larger than the diameter of rod *d*, so that the water may flow up through the piston when valve D is opened.

E is a ferrule that is screwed into the barrel B². This ferrule has an opening down through it to receive the rod, which opening for part of its depth is enlarged to accommodate a packing, *a*, and recessed packing-cap *a'*, through which rod *d* also passes. A thimble, G, is screwed onto ferrule E, and a push-button, G', that slides in thimble G, is screwed onto the upper end of rod *d*. This push-button is hollow and incloses a spring, *g*, that rests on cap *a'*, and has a tendency to lift the rod *d* and close valve D.

The operation of my device is as follows: When the parts are in the position shown in Figs. 1 and 2 of the drawings, the water is shut off. Now, to let the water on, the button G' is depressed, causing rod *d* to open valve D. The water then rushes up through the piston, and, acting on its head *b*, depresses it

and opens valve C, which remains open as long as button G' is depressed; but as soon as button G' is released valve D closes, and the pressure from the main slowly closes valve C as the water above the piston-head finds its way down between it and the barrel into chamber B, the water above the piston-head forming a cushion, that prevents any such sudden action of the valve as would cause the pounding that is so objectionable in valves of ordinary construction. The lower rim of button G' is reduced in thickness, and is provided with a lug or lugs, *g'*, above which a pin, *g*², on the inside of thimble G may be made to engage by depressing the button and turning it slightly, and when this is done the valve is held open to permit a continuous flow of water through chamber B and spout H.

Having thus fully described my invention, what I claim as new, and desire to secure by Letters Patent, is—

1. The combination of the chamber B, the piston B', the valve C, the rod *d*, having valve D at one end and push-button and closing-spring at its opposite end, and the locking appliances *g'* and *g*², substantially as set forth.

2. The combination, with the chamber B and its barrel B², of the recessed ferrule E, having packing *a*, the closing-cap *a'*, and the thimble G for receiving the exterior push-button and its spring, substantially as specified.

3. The combination of the thimble G, having pin *g*², with the push-button G', having locking-lug *g'*, rod *d*, and spring *g*, substantially as shown.

4. The combination of the stand A, the chamber B, the recessed ferrule E, the packing *a*, the exteriorly-threaded cap *a'* within the encircling-thimble G, the main self-closing valve C, and the valve D, operable by the rod *d*, substantially as described.

5. The combination, with the chamber B, of the piston B', the valve C, having its seat upon the lower end of the chamber B, the valve D, having its seat upon the lower end of the piston B', the ferrule E, having capped packing-chamber, and the rod *d*, connected to the valve D, and adapted by the provision of the locking appliances *g'* and *g*² to be held either in an open or in a closed position.

6. The combination, with the chamber B,
interiorly threaded at its outer end, of the fer-
rule E, exteriorly threaded at either end, the
thimble G, provided with pin g^2 , and engag-
5 ing at its inner end with the exterior end of
the ferrule, the interior cap, a' , exteriorly
threaded and closing the packing-chamber
within the ferrule, the spring g , and the push-
button G' , provided with lug g' and carrying
10 the valve-rod d , substantially as described.

In testimony that I claim the foregoing I
have hereunto set my hand, at Milwaukee, in
the county of Milwaukee and State of Wis-
consin, in the presence of two witnesses.

PHILIP A. BOWEN.

Witnesses:

STANLEY S. STOUT,
JOHN W. SUETTERLE.