



US00D580327S

(12) **United States Design Patent**
Lamm

(10) **Patent No.:** **US D580,327 S**

(45) **Date of Patent:** **** Nov. 11, 2008**

(54) **VEHICLE FRONT FENDER**

(75) Inventor: **Stefan Lamm, Köln (DE)**

(73) Assignee: **Ford Global Technologies, LLC,**
Dearborn, MI (US)

(**) Term: **14 Years**

(21) Appl. No.: **29/298,823**

(22) Filed: **Dec. 13, 2007**

(30) **Foreign Application Priority Data**

Aug. 22, 2007 (DE) 4 07 04 248

(51) **LOC (8) Cl.** **12-16**

(52) **U.S. Cl.** **D12/184**

(58) **Field of Classification Search** D12/184,
D12/196, 90-92; 280/152.1, 847-849, 851;
296/181.1, 181.5

See application file for complete search history.

(56) **References Cited**

U.S. PATENT DOCUMENTS

- D525,925 S * 8/2006 Minowa D12/184
- D526,257 S * 8/2006 Konaka D12/196
- D536,648 S * 2/2007 Fujimaki D12/184
- D562,747 S * 2/2008 Golden et al. D12/184
- D567,159 S * 4/2008 Saridakis et al. D12/184

D572,269 S * 7/2008 Fullerton et al. D14/496

* cited by examiner

Primary Examiner—Melody N Brown

(74) *Attorney, Agent, or Firm*—Damian Porcari

(57) **CLAIM**

The ornamental design for a vehicle front fender, as shown and described.

DESCRIPTION

FIG. 1 is a right elevational view of a right vehicle front fender (the left vehicle front fender being a mirror of the right and is not illustrated);

FIG. 2 is a front elevational view of the vehicle front fender;

FIG. 3 is a rear elevational view of the vehicle front fender;

FIG. 4 is a left elevational view of the vehicle front fender;

FIG. 5 is a top plan view of the vehicle front fender; and,

FIG. 6 is a bottom plan view of the vehicle front fender.

To the extent that any feature lines are illustrated, they are intended to illustrate the crest and valley of the feature and are not necessarily sharp bends in the part. Shading is used to illustrate the curvature of the part and not color. Views are orthogonal projections unless otherwise noted. The various views are not necessarily to scale in order to better illustrate the design.

1 Claim, 6 Drawing Sheets

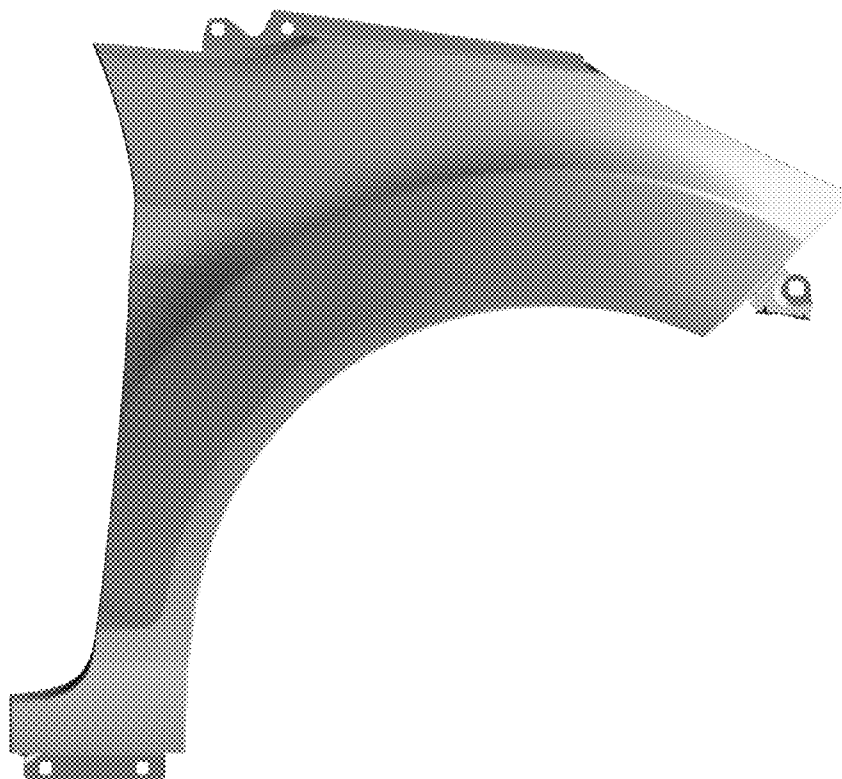

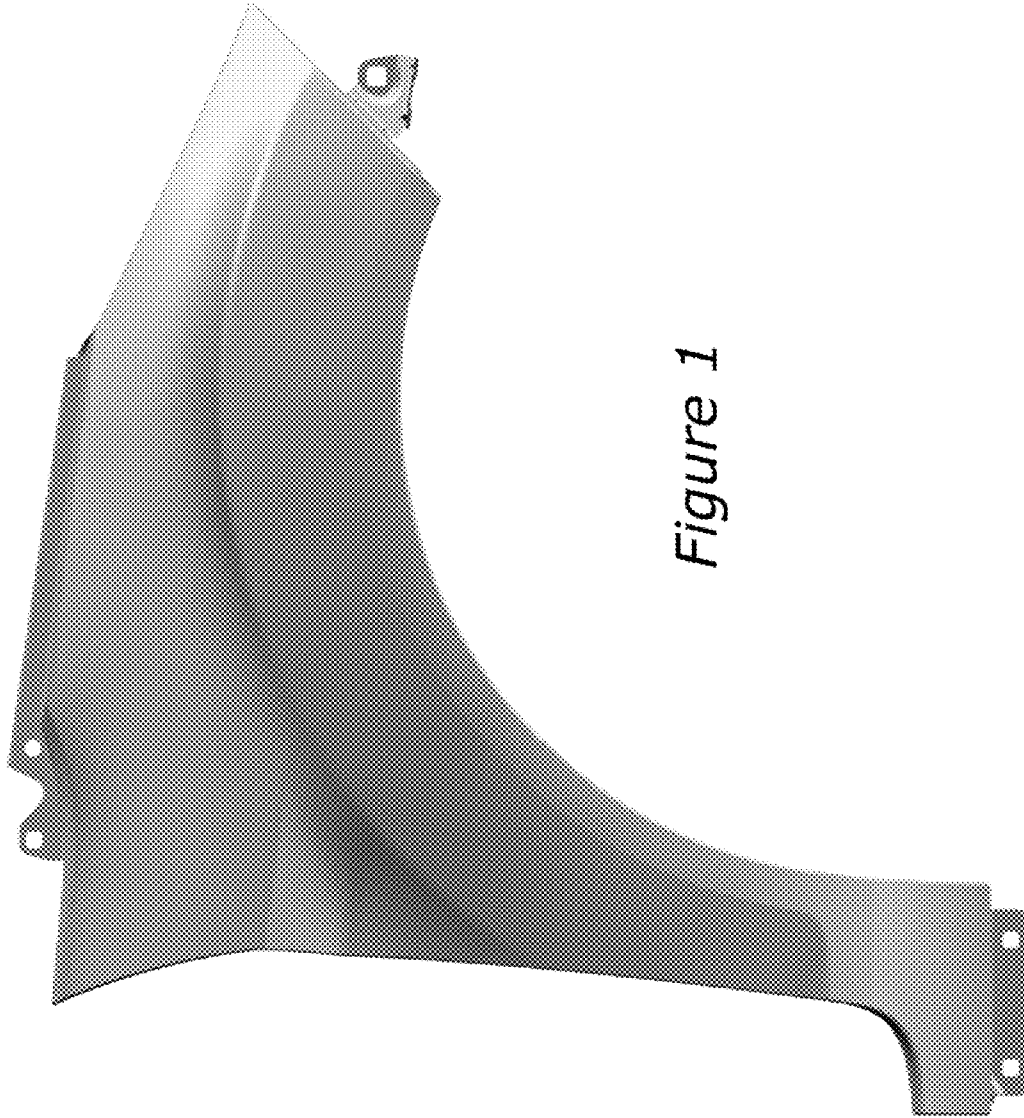

Figure 1

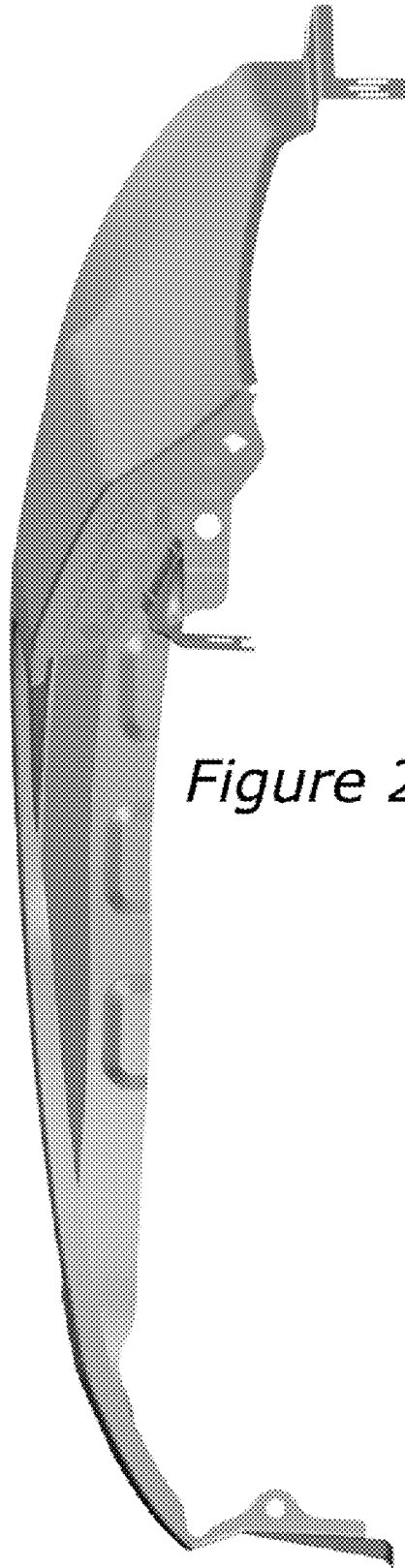

Figure 2

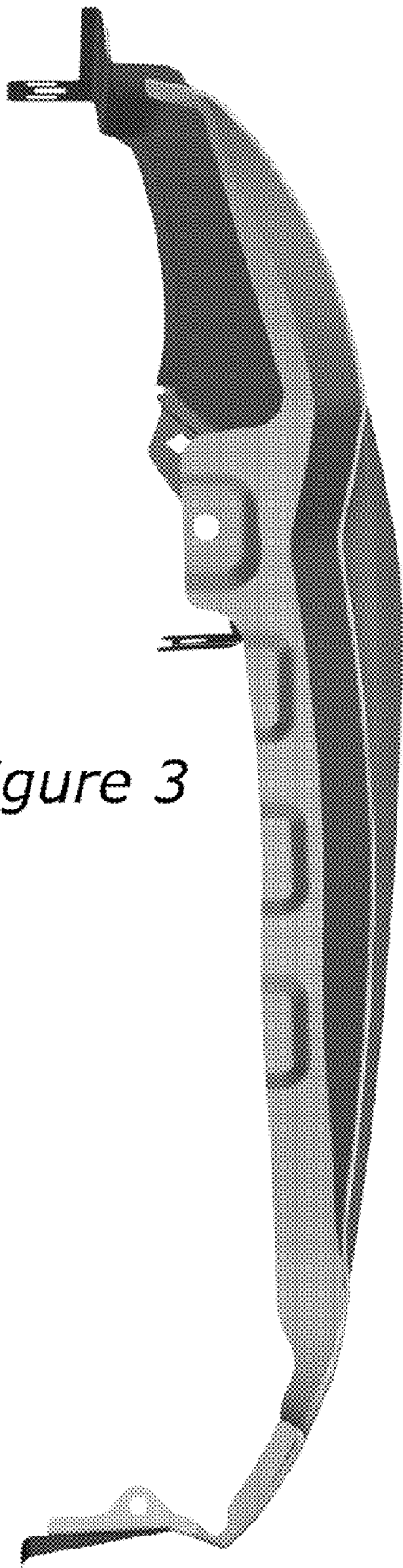

Figure 3

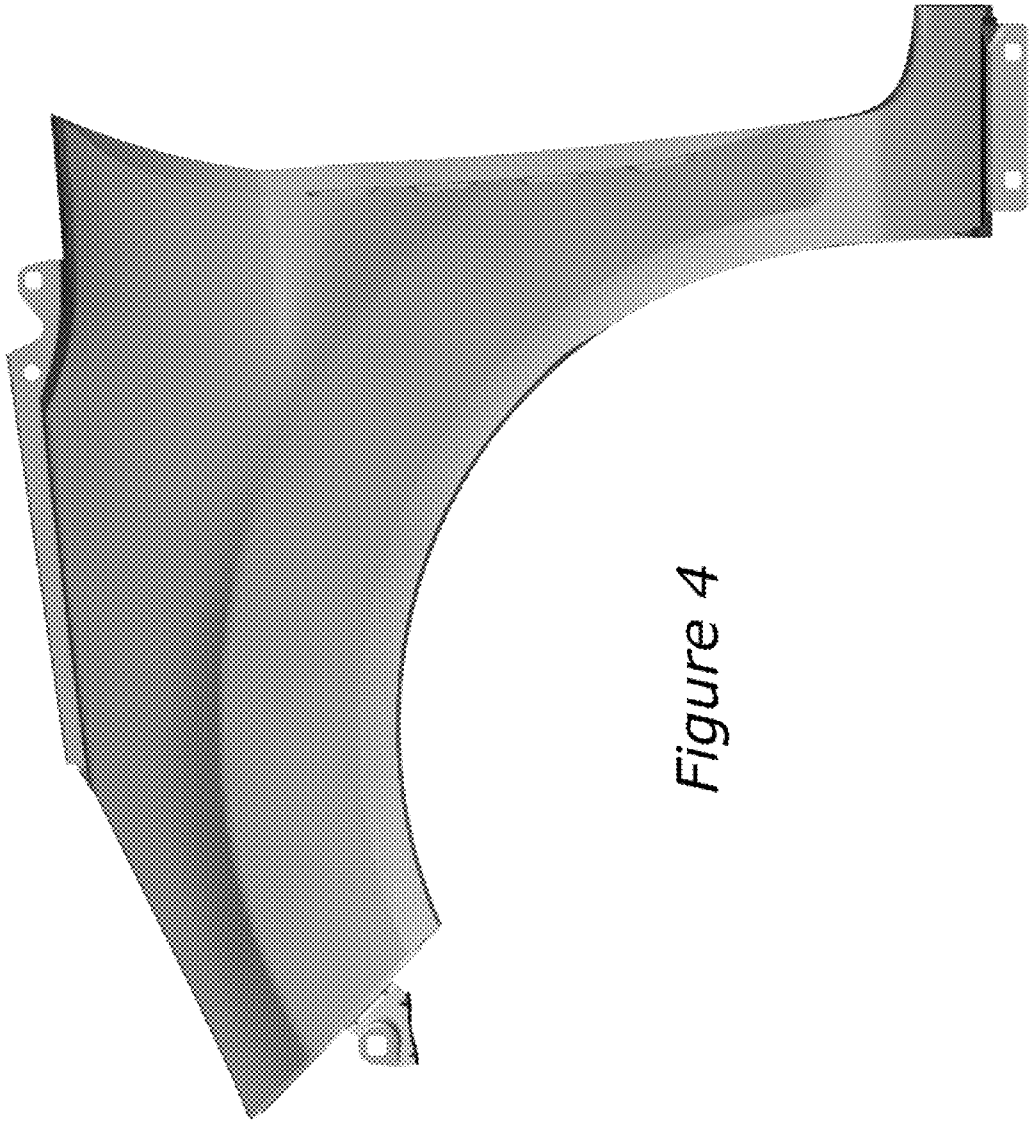
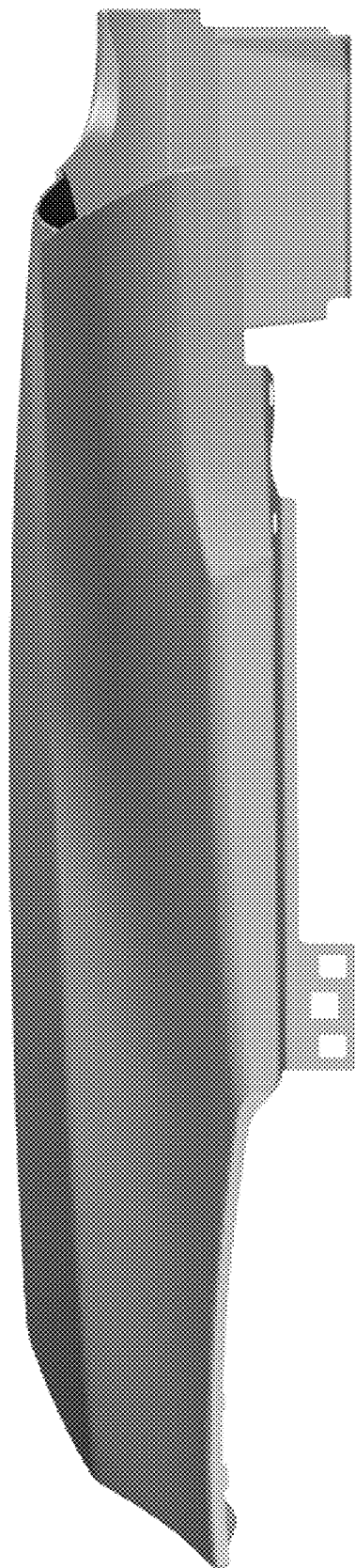

Figure 4

Figure 5



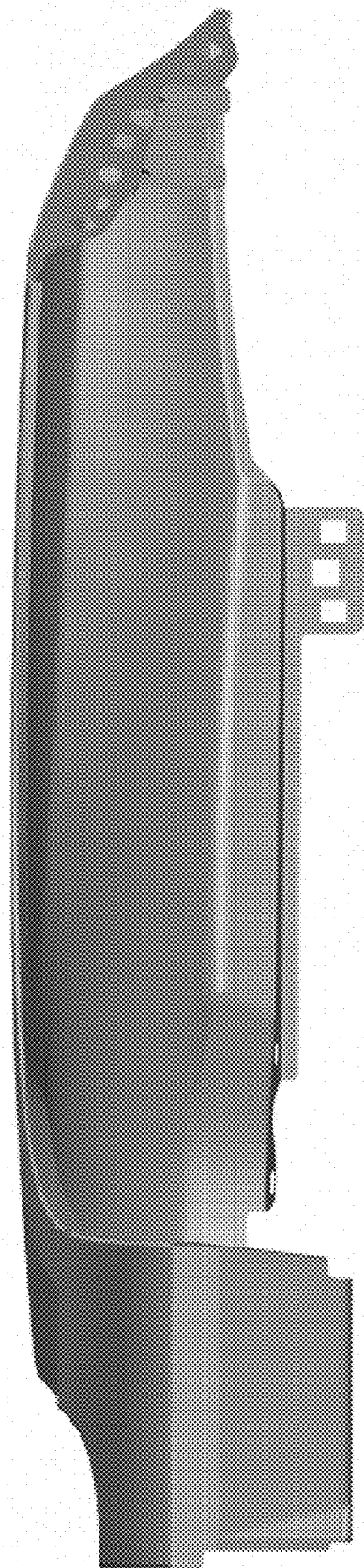

Figure 6