

(19) World Intellectual Property  
Organization  
International Bureau



(43) International Publication Date  
23 June 2005 (23.06.2005)

PCT

(10) International Publication Number  
**WO 2005/056253 A1**

- (51) International Patent Classification<sup>7</sup>: **B26B 21/44**, F16K 15/18
- (74) Agent: **MICHAUD, Richard**; Michaud-Duffy Group LLP, 306 Industrial Park Road, Suite 206, Middletown, CT 06457 (US).
- (21) International Application Number: PCT/US2004/040931
- (81) Designated States (unless otherwise indicated, for every kind of national protection available): AE, AG, AL, AM, AT, AU, AZ, BA, BB, BG, BR, BW, BY, BZ, CA, CH, CN, CO, CR, CU, CZ, DE, DK, DM, DZ, EC, EE, EG, ES, FI, GB, GD, GE, GH, GM, HR, HU, ID, IL, IN, IS, JP, KE, KG, KP, KR, KZ, LC, LK, LR, LS, LT, LU, LV, MA, MD, MG, MK, MN, MW, MX, MZ, NA, NI, NO, NZ, OM, PG, PH, PL, PT, RO, RU, SC, SD, SE, SG, SK, SL, SY, TJ, TM, TN, TR, TT, TZ, UA, UG, US, UZ, VC, VN, YU, ZA, ZM, ZW.
- (22) International Filing Date: 6 December 2004 (06.12.2004)
- (25) Filing Language: English
- (26) Publication Language: English
- (30) Priority Data: 10/730,618 8 December 2003 (08.12.2003) US
- (71) Applicant (for all designated States except US): **EVEREADY BATTERY COMPANY, INC.** [US/US]; 533 Maryville University Drive, St. Louis, MO 63164 (US).
- (84) Designated States (unless otherwise indicated, for every kind of regional protection available): ARIPO (BW, GH, GM, KE, LS, MW, MZ, NA, SD, SL, SZ, TZ, UG, ZM, ZW), Eurasian (AM, AZ, BY, KG, KZ, MD, RU, TJ, TM), European (AT, BE, BG, CH, CY, CZ, DE, DK, EE, ES, FI, FR, GB, GR, HU, IE, IS, IT, LT, LU, MC, NL, PL, PT, RO,

[Continued on next page]

(54) Title: SHAVING APPARATUS WITH PIVOT-ACTUATED VALVE FOR DELIVERY OF SHAVING AID MATERIAL

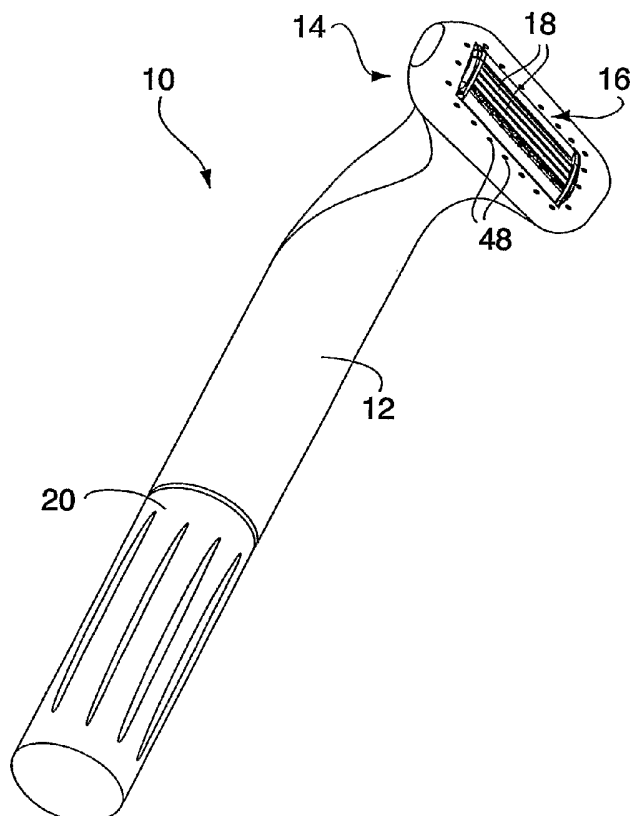

(57) Abstract: A shaving apparatus includes a reservoir (23) for storing a shaving aid material, a razor cartridge (16) having at least one razor blade (18), and a valve (26, 126) selectively actuatable by movement of the razor cartridge between a first position and a second position. In the first position the valve permits passage of a shaving aid material from the reservoir, and in the second position the valve substantially prevents the passage of the shaving aid material from the reservoir.

WO 2005/056253 A1



SE, SI, SK, TR), OAPI (BF, BJ, CF, CG, CI, CM, GA, GN, GQ, GW, ML, MR, NE, SN, TD, TG).

*For two-letter codes and other abbreviations, refer to the "Guidance Notes on Codes and Abbreviations" appearing at the beginning of each regular issue of the PCT Gazette.*

**Published:**

- *with international search report*
- *before the expiration of the time limit for amending the claims and to be republished in the event of receipt of amendments*

**SHAVING APPARATUS WITH PIVOT-ACTUATED VALVE FOR  
DELIVERY OF SHAVING AID MATERIAL**

**Background of the Invention**

5

**Technical Field**

This disclosure relates generally to shaving apparatuses, and, more particularly, to shaving apparatuses having pivot-actuated valves through which shaving aid material can be delivered.

10

**Background Information**

The process of removing hair from a skin surface typically includes the application of a shaving aid material to the skin surface and the separate step of shaving the hair from the skin surface using a safety razor. Safety razors typically include a disposable razor cartridge mounted in a reusable handle or a handle and cartridge combined into a unitary disposable unit. Most razor cartridges include a frame, at least one razor blade, and a member that includes an additional shaving aid material attached to the frame. The additional shaving aid material typically includes at least one suitable agent (e.g., a lubricating agent, a drag-reducing agent, a depilatory agent, etc.) that enhances the shaving process.

20

Shaving aid materials applied in preparation for shaving are generally soap-based compositions that are lathered and applied to the skin surfaces. The compositions may be pre-lathered and applied as creams, or they may be in bar form and rubbingly applied to the skin surfaces by the person shaving. For applications of either creams or bars, the application of the shaving aid and the actual shaving of hair from the skin surface are executed in separate steps.

25

The commercial success of a razor assembly depends upon the ease with which a shaving process using the razor assembly can be executed. In particular, the application of the shaving aid material and the actual shaving of the hair in separately executed steps oftentimes adversely affects the overall efficiency of the shaving process. What is needed, therefore, is an apparatus capable of delivering the shaving aid material and executing a shaving operation in a single step.

30

**Disclosure of the Invention**

According to the present invention, a shaving apparatus includes a reservoir for storing a shaving aid material, a razor cartridge having at least one razor blade, and a valve selectively actuatable by movement of the razor cartridge between a first position and a second position. In the first position the valve permits passage of a shaving aid material from the reservoir, and in the second position the valve substantially prevents the passage of the shaving aid material from the reservoir. In one embodiment, the valve includes a spring-loaded plug element and an orifice, each being cooperable to permit or prevent the passage of the shaving aid material. In another embodiment, the valve comprises first and second plates engagable with each other such that during the engagement of the plates, the passage of the shaving material from the reservoir is prevented.

The present invention further includes a valve for a shaving apparatus. The valve includes a plug element cooperably connected to a razor cartridge and an orifice in which the plug element is received. In such a valve, the razor cartridge is movable between first and second positions to permit or prevent the passage of shaving aid material from the reservoir. In one embodiment, the plug element is a spring-loaded ball disposed on a stem, and in a second embodiment the plug element is a first plate engagable by a second plate, the plates being capable of being biased together by a spring.

The shaving apparatus having the valve selectively actuatable by movement of the razor cartridge between first and second positions to effect the passage of the shaving aid material has several advantages over similar apparatuses of the related art. First, such an apparatus allows for the delivery of the shaving aid material to the surface to be shaved during the shaving operation, thereby avoiding the need for applying the shaving aid material in a separate step. Such an application allows a person to reduce the amount of time spent shaving. Second, because the shaving aid material is incorporated directly into the structure of the razor handle, the need for purchasing razors and shaving aid material separately is avoided. Third, the amount of wasted shaving material is reduced. In particular, by applying shaving aid material directly from the shaving apparatus to the surface to be shaved, the large quantities of unused shaving cream that remain on the hand of the person shaving at the end of the shaving operation are eliminated. These and other advantages will be evident from the Detailed Description presented below.

### **Brief Description of the Drawings**

FIG. 1 is a perspective view of a shaving apparatus from which a shaving aid material is delivered in response to the engagement of the apparatus with a hirsute surface.

FIG. 2 is a cross-sectional view of a shaving apparatus showing a valve that is  
5 actuatable in response to the pivoting of a razor cartridge.

FIG. 3 is a cross sectional view of a shaving apparatus showing an alternate embodiment of a valve that is actuatable in response to the pivoting of the razor cartridge.

FIG. 4 is a plan view of a head assembly of a shaving apparatus showing ports through which shaving aid material is delivered in response to the pivoting of a razor  
10 cartridge.

### **Detailed Description**

Disclosed herein are exemplary embodiments of articles for shaving and, more particularly, articles for the automatic delivery of shaving aid materials from shaving aid  
15 apparatuses. Preferably, the shaving apparatus as recited herein is suited for wet shaving applications, e.g., applications in which the surface to be shaved is wetted prior to its receiving a shaving aid preparation (e.g., shaving cream, gel, or the like) and its engagement by a razor blade.

Referring to FIG. 1, a shaving apparatus from which a shaving aid material is  
20 delivered in response to the engagement of the apparatus with a hirsute surface is shown generally at 10. The shaving apparatus 10 includes a handle 12, a razor cartridge 16 disposed in a head assembly 14 coupled or integrally formed with the handle 12, at least one razor blade 18 operably disposed in the razor cartridge 16, and a valve selectively actuatable by movement of the razor cartridge 16 between first and second positions to permit or  
25 prevent the delivery of shaving aid material from the shaving apparatus 10.

The structure of the handle 12 preferably defines a reservoir in which the shaving aid material is stored. In one exemplary embodiment of the shaving apparatus 10, the handle 12 includes at least one wall formed to define a tubular structure that is conducive to being grasped by a person executing a shaving operation. The handle 12 may be configured  
30 to have an ergonomic design that provides comfort during the shaving operation. The end of the handle 12 distal from the end at which the razor cartridge 16 is mounted may include an opening that provides access to the reservoir. The opening is preferably coverable by a cap 20, which may be disposed over the opening and retained on the handle 12 by any one

or a combination of various mechanisms including, but not limited to, frictional engagement of the handle 12 and the cap 20, the engagement of a ridge formed in either the cap 20 or the outer surface of the handle 12 with a groove formed in the other of the outer surface of the handle 12 or the cap 20, a thread means, or the like. Alternatively, the handle may be  
5 closed to prevent access to the reservoir when, for example, the reservoir contains only enough shaving aid material such that upon depletion of the reservoir the shaving apparatus 10 is intended to be disposed.

The shaving apparatus 10 in which one exemplary embodiment of the valve can be seen is shown with reference to FIG. 2. The valve, which is shown at 26, includes a plug  
10 element that selectively permits or prevents the flow of shaving aid material through an orifice. As shown, the plug element is a ball 28 disposed on a stem 30. It should be understood by those of skill in the art, however, that other configurations and geometries including disks, plates, and the like, may be utilized as plug elements. The ball 28 is biased by a spring 32 in the direction of flow of the shaving aid material from the reservoir 23 and  
15 is cooperable with a seat 34 through which the orifice is disposed.

The stem 30 is positioned in a manifold 36, through which fluid communication may be maintained between the reservoir 23 and conduits 46 that extend to a surface adjacent to the razor cartridge 16 to supply shaving aid material to the surface to be shaved. The end of the stem 30 distal from the ball 28 is engagable by a protrusion 44 on the razor cartridge 16,  
20 which is articulatively coupled to the handle 12 at a pivot point 42 such that the razor cartridge 16 is movable within the opening of the head assembly 14 in response to the engagement of the razor cartridge 16 with the surface to be shaved. A seal member 40 (e.g., the O-ring shown in FIGS. 2 and 3, or packing, lip seal, etc.) is disposed adjacent the stem 30 to prevent the escape of shaving aid material around the stem 30. The seal member 40  
25 may be integral with the stem 30 or independent of the stem 30.

The operation of the valve 26 is effected through the cooperation of the stem 30 and the razor cartridge 16. Upon movement of the razor cartridge 16 from a first position to a second position, the protrusion 44 causes the stem 30 to translate in the manifold 36 to selectively seat and unseat the ball 28, thereby causing the intermittent opening and closing  
30 of the valve 26. Upon the opening of the valve 26 (unseating of the ball 28), shaving aid material is transferred through the orifice defined by the seat 34 to the manifold 36 and into the conduits 46. The shaving aid material is dispensed from the conduits 46 to the razor cartridge 16, which is positioned on the surface to be shaved.

The driving force for the transfer of the shaving aid material from the reservoir 23 is a pressure differential. The pressure differential may be supplied by pressurization of the shaving aid material using an inert gas, a pre-packaged insertable vessel from which the shaving aid preparation is dispensed under a spring-bias mechanism (shown with reference  
5 to FIG. 3), or the like.

Referring now to FIG. 4, another exemplary embodiment of a valve for the shaving apparatus 10 is shown at 126. The valve 126 includes a tube 136 and a gate 138. This embodiment is not limited to a tube, however, and may alternately include other types of enclosed conduits having one or more walls. The tube 136 is resiliently collapsible to open  
10 or close the valve 126 and thereby selectively prevent or permit flow through the tube 136. The gate 138 includes a spring 139 and is normally biased to act against the tube 136, pinching the tube 136 into a closed position. The spring 139 is shown as a leaf-type spring. Other spring mechanisms for pinching the conduit 136 may be used alternatively.

The razor cartridge 16 is mounted at or near one end of a pivotal arm 41 such that  
15 the razor cartridge 16 is movable within the opening of the head assembly 14 in response to the engagement of the razor cartridge 16 with the surface to be shaved. The arm 41 includes a protrusion 44 that engages the gate 138. Upon pivotal movement of the arm 41 (and the attached protrusion 44), the gate 138 is deflected and drawn out of engagement with the tube 136, thereby causing the valve 126 to open and allow the shaving aid material  
20 to flow from the reservoir 23.

Conduits 46 are disposed within the handle 12 and the head assembly 14 to provide for the transfer of the shaving aid material from the valve 126 (upon opening of the valve 126) to the surface at which the razor cartridge 16 engages the surface to be shaved. The conduits 46 preferably provide communication between the outlet of the valve 126 and ports  
25 48 adjacent to the opening in the head assembly 14 in which the razor cartridge 16 moves. In a preferred embodiment, shaving aid material flows into the conduits 46 as close to the outlet of the valve 26 as possible, thereby avoiding or at least minimizing contact of the protrusion 44 and the pivot point 42 with the shaving aid material.

As can be seen, the reservoir 23 may be configured to receive the shaving aid  
30 material in a pre-packaged form (e.g., in a foil- or plastic vessel manually insertable into the handle 12). In such an embodiment, an outlet 24 of the reservoir 23 preferably comprises a spike 28 that punctures the foil- or plastic vessel containing the shaving aid material upon insertion of the vessel into the handle 12. The cap 20 preferably includes a piston 30 or a

plate biased by a spring 31 that provides the pressure for transferring the shaving aid material through the outlet 24 to the valve 126.

Referring now to FIG. 4, the positioning of ports 48 at the surface of the head assembly 14 into which the razor cartridge 16 is pivotally mounted is shown. Although  
5 only six ports 48 are illustrated, and although the ports 48 are illustrated as being disposed at opposing sides of the razor cartridge 16, it should be understood that any number of ports 48 may be disposed at any position around the razor cartridge 16. Furthermore, it should be understood that the illustrated configuration of ports 48 may be utilized with the  
embodiments of the valves shown in FIG. 2 or FIG. 3 as well as any other valve.

10 While the invention has been described with reference to exemplary embodiments, it will be understood by those skilled in the art that various changes may be made and equivalents may be substituted for elements thereof without departing from the scope of the invention. In addition, many modifications may be made to adapt a particular situation or material to the teachings of the invention without departing from the essential scope thereof.  
15 Therefore, it is intended that the invention not be limited to the particular embodiments disclosed as the best mode contemplated for carrying out this invention, but that the invention will include all embodiments falling within the scope of the appended claims.



## CLAIMS

1. A shaving apparatus, comprising:  
a reservoir for storing a shaving aid material;  
a razor cartridge having at least one razor blade; and  
a valve selectively actuatable by movement of the razor cartridge between a first  
5 position and a second position;  
wherein in the first position the valve permits passage of shaving aid material from the reservoir, and in the second position the valve substantially prevents passage of shaving aid material from the reservoir.
2. The shaving apparatus of claim 1, wherein the valve comprises a spring-loaded plug element and an orifice, the spring-loaded plug element and the orifice being cooperable to permit or prevent the passage of shaving aid material from the reservoir.
3. The shaving apparatus of claim 2, wherein the spring-loaded plug element is disposed on a stem.
4. The shaving apparatus of claim 3, further comprising a manifold in which the stem is axially translatable.
5. The shaving apparatus of claim 3, further comprising a seal member disposed adjacent the stem.
6. The shaving apparatus of claim 1, wherein the spring-loaded plug element is a ball.
7. The shaving apparatus of claim 1, wherein the valve comprises a resiliently collapsible conduit and a gate, wherein the gate is normally biased against the conduit in a first position to prevent the flow of the shaving aid material from the reservoir, and is selectively movable to a second position wherein the flow of shaving aid material from the  
5 reservoir through the conduit is permitted.

8. The shaving apparatus of claim 7, wherein the conduit is a tube.
9. The shaving apparatus of claim 7, wherein the gate includes a leaf spring.
10. A valve for a shaving apparatus, comprising:  
a plug element cooperably connected to a razor cartridge;  
and an orifice in which the plug element is received;  
wherein the razor cartridge is movable between a first position and a second position  
5 such that the plug element permits passage of shaving aid material from a reservoir when  
the razor cartridge is in the first position and prevents passage of shaving aid material from  
the reservoir when the razor cartridge is in the second position.
11. The valve of claim 10, wherein the plug element is a spring-loaded ball.
12. The valve of claim 11, wherein the ball is disposed on a stem.
13. The valve of claim 12, wherein the stem is operably connected to the razor cartridge.
14. The valve of claim 10, wherein the plug element comprises a first plate engagable by  
a second plate.
15. The valve of claim 14, wherein the engagement of the first plate and the second  
plate is effected by the action of a spring operably connected to the razor cartridge.

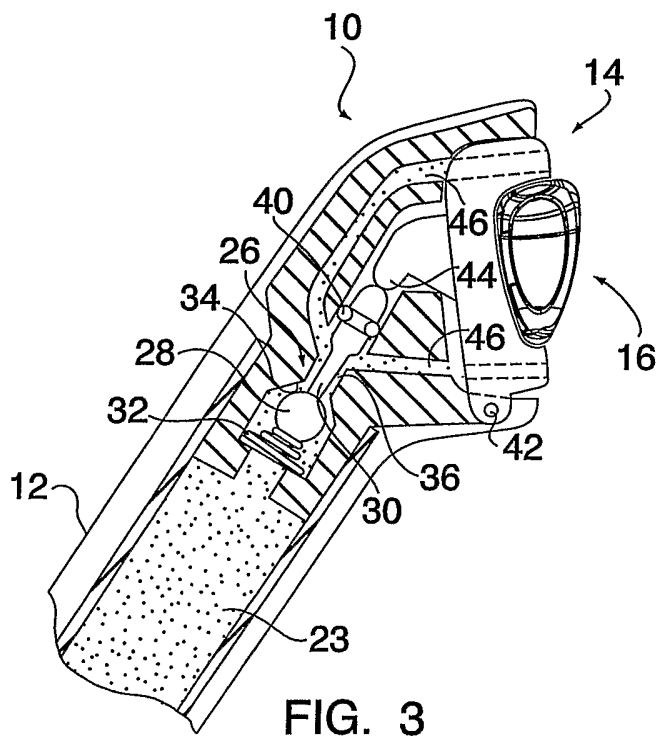
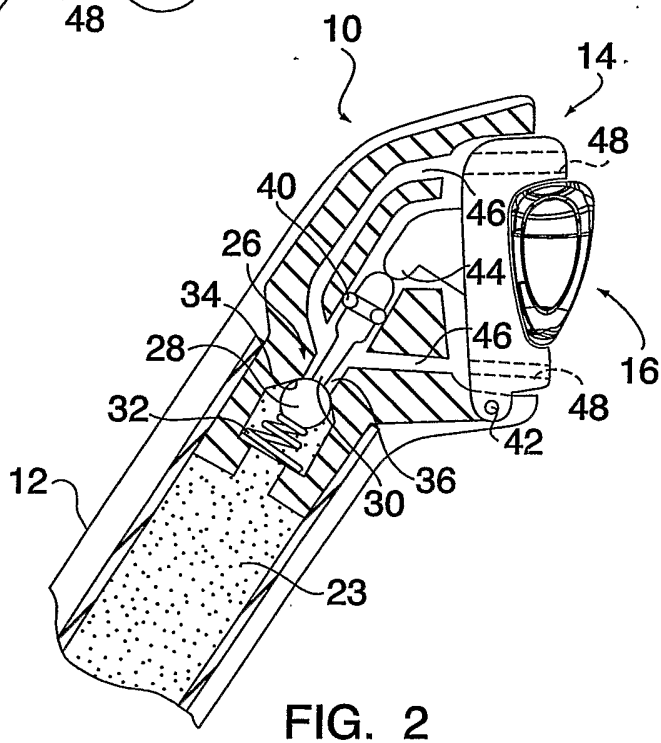
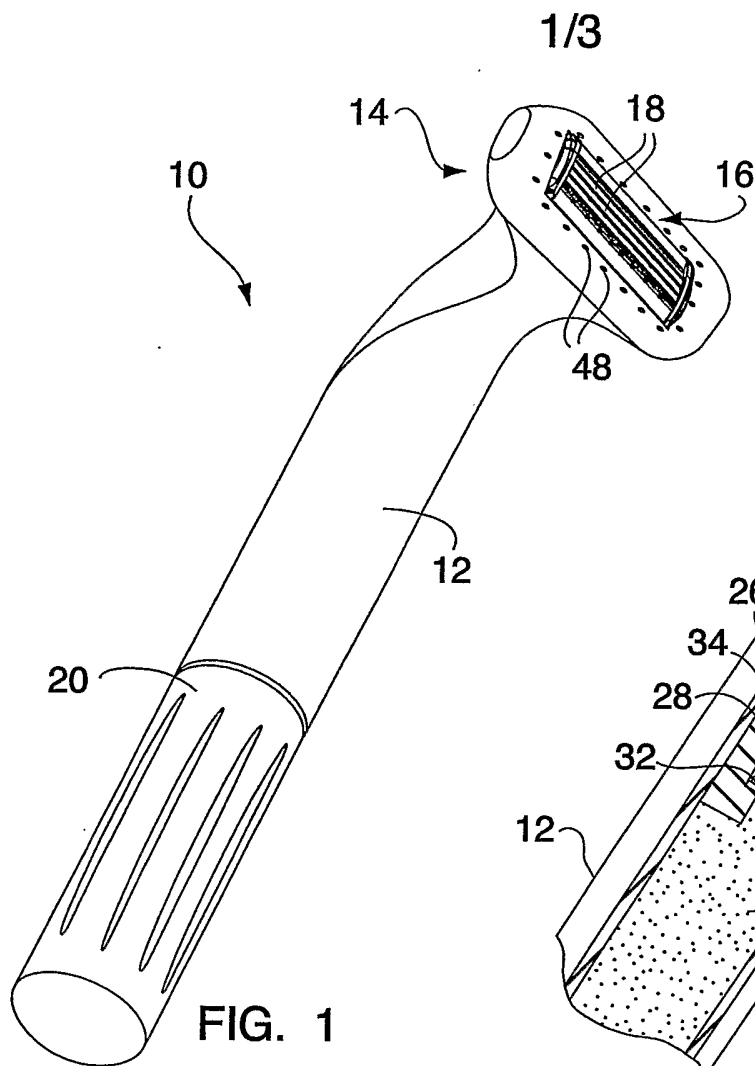

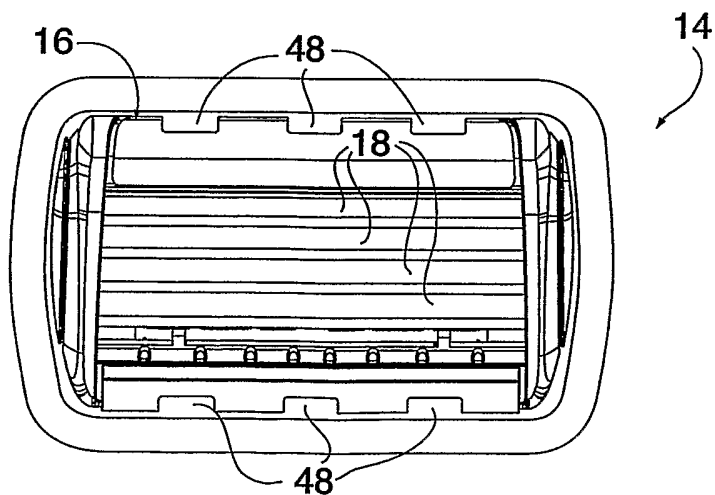
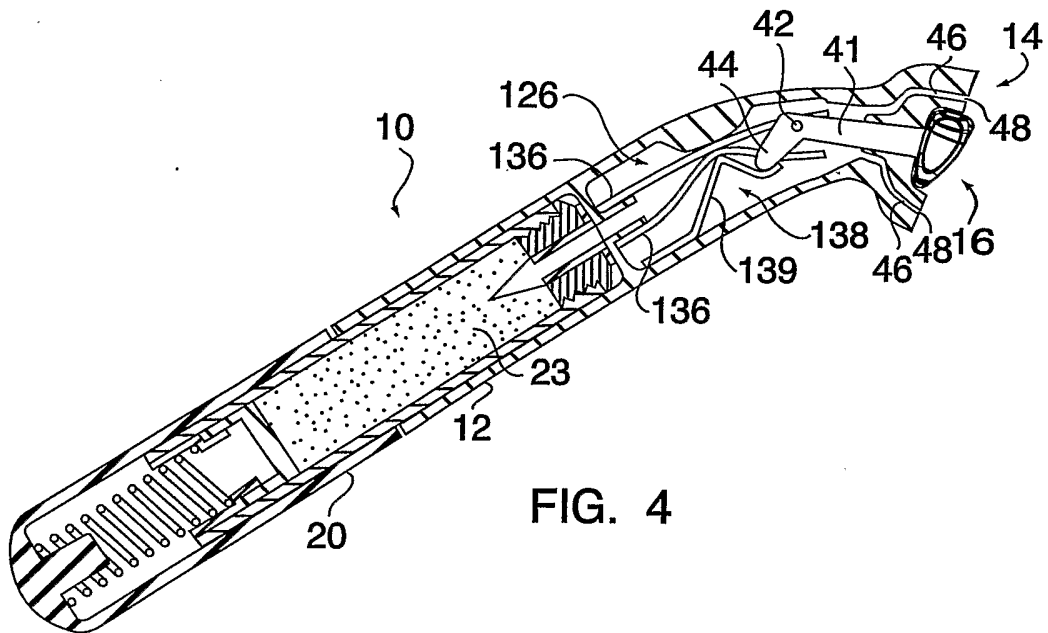

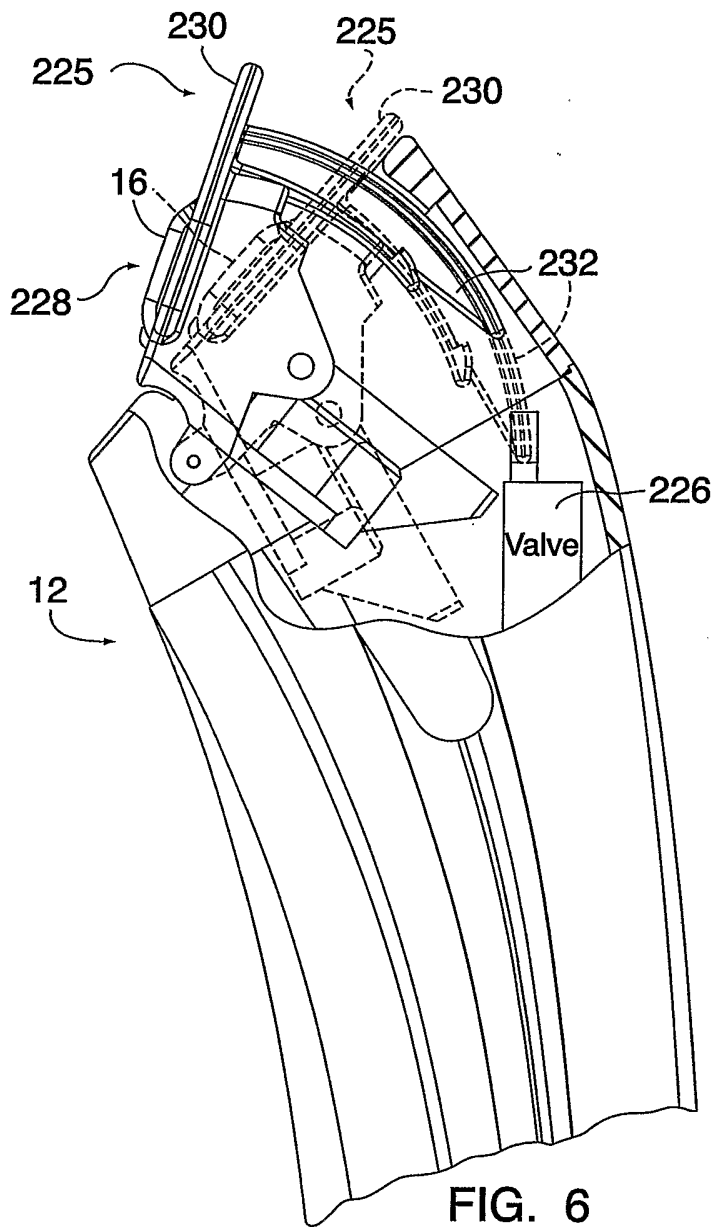

INTERNATIONAL SEARCH REPORT

International Application No  
PCT/US2004/040931

**A. CLASSIFICATION OF SUBJECT MATTER**  
IPC 7 B26B21/44 F16K15/18

According to International Patent Classification (IPC) or to both national classification and IPC

**B. FIELDS SEARCHED**  
Minimum documentation searched (classification system followed by classification symbols)  
IPC 7 B26B F16K

Documentation searched other than minimum documentation to the extent that such documents are included in the fields searched

Electronic data base consulted during the international search (name of data base and, where practical, search terms used)  
EPO-Internal

**C. DOCUMENTS CONSIDERED TO BE RELEVANT**

Category °	Citation of document, with indication, where appropriate, of the relevant passages	Relevant to claim No.
X	US 2002/023351 A1 (SIMMS GRAHAM JOHN) 28 February 2002 (2002-02-28) paragraph '0021! - paragraph '0027!; figures 1-5	1-3, 5, 10
X	US 3 726 009 A (HACKMYER S, US) 10 April 1973 (1973-04-10) column 2, line 34 - column 3, line 58; figures 1-3	1, 10
A	US 2002/029478 A1 (HAWES CHRISTOPHER MARTIN ET AL) 14 March 2002 (2002-03-14) paragraph '0035!; figures 1-7  ----- -/--	

Further documents are listed in the continuation of box C.       Patent family members are listed in annex.

° Special categories of cited documents :

*A* document defining the general state of the art which is not considered to be of particular relevance	*T* later document published after the international filing date or priority date and not in conflict with the application but cited to understand the principle or theory underlying the invention
*E* earlier document but published on or after the international filing date	*X* document of particular relevance; the claimed invention cannot be considered novel or cannot be considered to involve an inventive step when the document is taken alone
*L* document which may throw doubts on priority claim(s) or which is cited to establish the publication date of another citation or other special reason (as specified)	*Y* document of particular relevance; the claimed invention cannot be considered to involve an inventive step when the document is combined with one or more other such documents, such combination being obvious to a person skilled in the art.
*O* document referring to an oral disclosure, use, exhibition or other means	* & * document member of the same patent family
*P* document published prior to the international filing date but later than the priority date claimed	

Date of the actual completion of the international search  13 April 2005	Date of mailing of the international search report  20/04/2005
--	--

Name and mailing address of the ISA European Patent Office, P.B. 5818 Patentlaan 2 NL - 2280 HV Rijswijk Tel. (+31-70) 340-2040, Tx. 31 651 epo nl, Fax: (+31-70) 340-3016	Authorized officer  Maier, M
--	------------------------------------

## INTERNATIONAL SEARCH REPORT

International Application No  
PCT/US2004/040931

## C.(Continuation) DOCUMENTS CONSIDERED TO BE RELEVANT

Category °	Citation of document, with indication, where appropriate, of the relevant passages	Relevant to claim No.
A	FR 2 634 154 A (GUEDJ PATRICK) 19 January 1990 (1990-01-19) page 3, line 1 - line 4 page 5, line 14 - page 6, line 5; figures 4-6 -----	7
A	CH 653 595 A5 (RAYMOND VOISARD) 15 January 1986 (1986-01-15) the whole document -----	
A	US 4 908 945 A (JACOBSON ET AL) 20 March 1990 (1990-03-20) the whole document -----	

## INTERNATIONAL SEARCH REPORT

International Application No  
PCT/US2004/040931

Patent document cited in search report		Publication date	Patent family member(s)	Publication date
US 2002023351	A1	28-02-2002	AU 2454600 A	29-08-2000
			DE 60001055 D1	30-01-2003
			DE 60001055 T2	17-07-2003
			EP 1152872 A1	14-11-2001
			ES 2184694 T3	16-04-2003
			WO 0047374 A1	17-08-2000
US 3726009	A	10-04-1973	NONE	
US 2002029478	A1	14-03-2002	AT 267072 T	15-06-2004
			AU 5563199 A	14-03-2000
			BR 9913045 A	08-05-2001
			CA 2339022 A1	02-03-2000
			CN 1313804 A ,C	19-09-2001
			DE 69917462 D1	24-06-2004
			EP 1105260 A1	13-06-2001
			ES 2221425 T3	16-12-2004
			WO 0010780 A1	02-03-2000
FR 2634154	A	19-01-1990	FR 2634154 A1	19-01-1990
CH 653595	A5	15-01-1986	NONE	
US 4908945	A	20-03-1990	US 4791723 A	20-12-1988
			JP 1501604 T	08-06-1989
			WO 8806511 A1	07-09-1988